

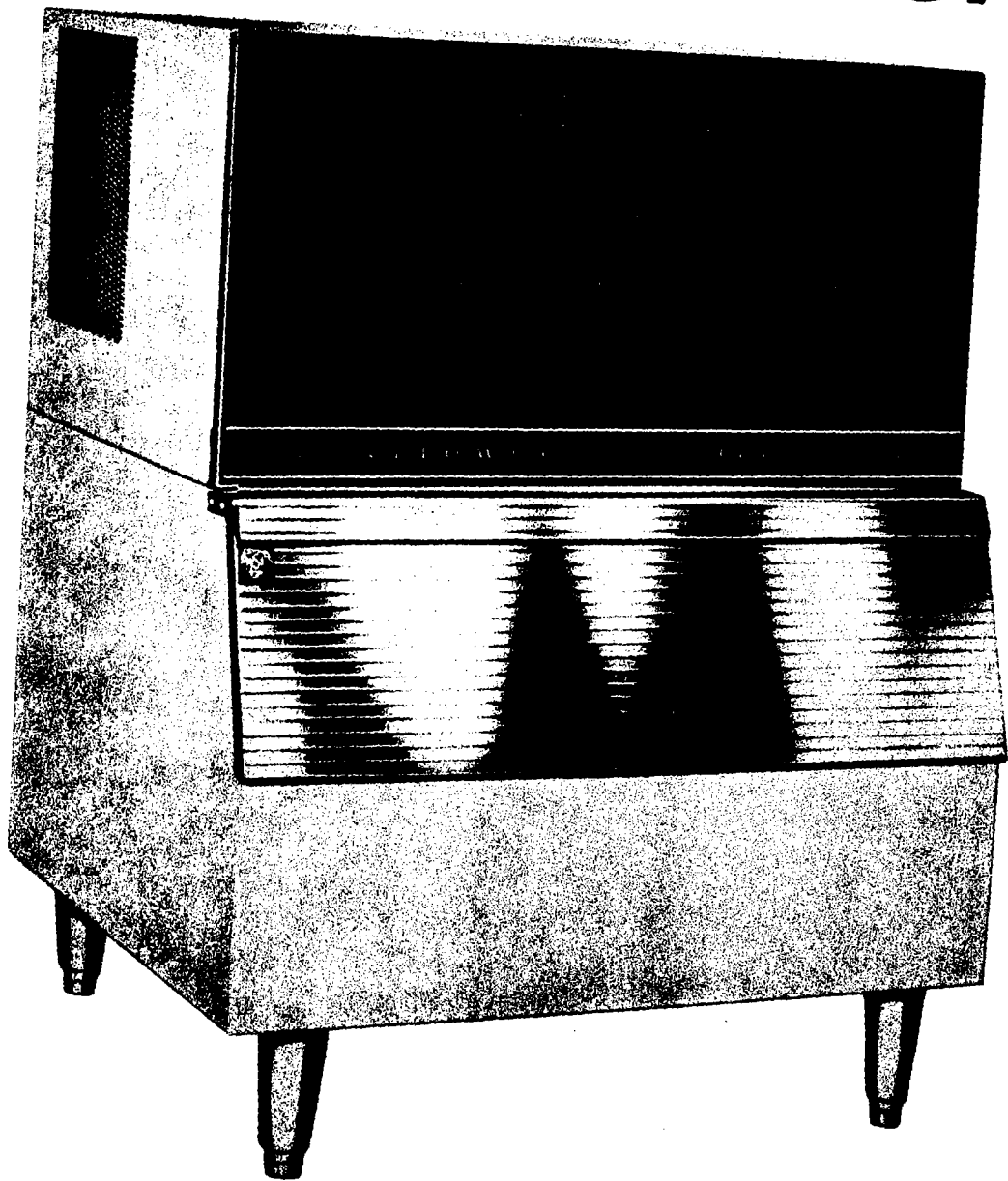

Manitowoc
A0400 SERIES ICE CUBER
SERVICE MANUAL



Manitowoc equipment works
Division of The Manitowoc Company, Inc.,

MANITOWOC
WISCONSIN

80-0044-1

TABLE OF CONTENTS

Uncrating and Inspection.....	Page 2
Location.....	Page 2
Setting Up Cabinet.....	Page 2
Leveling Ice Cuber.....	Page 2
Serial and Electrical Plate.....	Page 2
Removing Front Panel.....	Page 2
Removing Head Section Panels.....	Page 2
Electrical Connections.....	Page 2
General Requirements.....	Page 2
Connecting Power Supply.....	Page 2
Water Supply.....	Page 3
Connecting Water Supply.....	Page 3
Drain Connections.....	Page 3
Check List for Starting Machine.....	Page 3
Final Check List.....	Page 3
Controls.....	Page 4
Setting Timers.....	Page 5
Fig. 1 —.....	Page 6
Fig. 2 —.....	Page 7
Fig. 3 —.....	Page 8
Fig. 4 —.....	Page 9
Fig. 5 —.....	Page 10
Fig. 6 —.....	Page 11
Fig. 7 —.....	Page 12
Fig. 8 — Water System Sketch.....	Page 13
Water Pump Assembly.....	Page 14
Control Box Assembly.....	Page 15
Fig. 9 — Midtex Solid State Timer.....	Page 16
Fig. 10 — Omnetics Solid State Timer.....	Page 17
Fig. 11 — Control Box View of Solid State Timer	
Setting Instructions.....	Page 18
Fig. 12 — Midtex Timer Setting Instructions.....	Page 19
Fig. 13 —.....	Page 20
Fig. 14 —.....	Page 21
Ice Production — Lbs. per 24 Hours.....	Page 22
Specifications — "400" Series Models.....	Page 22
Bin Specifications — "400" Series Bin Options.....	Page 22
Service Analysis.....	Page 23-24
Specifications — 60 Cycle.....	Page 25
Specifications — 50 Cycle.....	Page 26
Cleaning Instructions.....	Page 27
Wiring Diagram — 60 Cycles.....	Page 28
Wiring Diagram — 50 Cycles.....	Page 29
Service and Parts Procedure.....	Page 30-31
Warranty.....	Page 32

FORWARD

Manitowoc Equipment Works, Division of the Manitowoc Company, Inc., Manitowoc, Wisconsin, presents this Service Manual to assist the service man with information concerning CONSTRUCTION, INSTALLATION, and MAINTENANCE of the MANITOWOC ICE MAKER.

The problems of the user and the service man have been given special emphasis in the development of the latest MANITOWOC Ice Machines.

If you encounter a problem which is not answered by this manual, please feel free to write or call the Service Department of the Manitowoc Equipment Works, Division of the Manitowoc Company, Inc., Manitowoc Wisconsin, describing the problem you have encountered. The Service Department will be happy to give you particularized advice and assistance. Whenever calling or writing, please state the complete model and serial number of the ice making equipment.

MANITOWOC EQUIPMENT WORKS

Div. of THE MANITOWOC CO., INC.
Manitowoc, Wisconsin 54220
(414) 682-0161

MODELS

This manual includes the following models:

"400" SERIES MODELS

AR-0400A	AD-0402A	AY-0404A
AR-0400AS	AD-0402AS	AY-0404AS
AR-0401W	AD-0403W	AY-0405W
AR-0401WS	AD-0403WS	AY-0405WS

WARRANTY

Parts and Material	One year — parts only
Compressor	Five years — parts only

Defective parts must be returned transportation prepaid.

(See "Ice Machine and Bin Warranty" page 32 and registration card shipped with the unit for warranty conditions.)

UNCRATING AND INSPECTION

All AO 400 Series Ice Cubers and Bins are shipped in separate corrugated cartons. To uncrate remove the staples around the lower edge of the carton, lift the carton upwards and off, and inspect for concealed damage. Machine section is held to the skid by two bolts. Remove these skid bolts and set the machine on the bin.

LOCATION

Some models are designed to slide under a 42 inch bar or any other convenient location. For maximum efficiency, pick a location away from sources of heat like radiators, ovens, other refrigeration condensing units, direct sunlight, etc. Provide space around the cabinet for air circulation. Air & water cooled models require a minimum of 5 inches at any louvered opening to the compressor compartment. Cabinets located in unheated areas must be protected from freezing or shut down and drained. When machine is in place, remove wooden wedges under compressor. These were placed there for shipping purposes.

SETTING UP CABINET

Uncrate bin and inspect for concealed damage. Screw the legs in the four holes in bottom of bin. Carefully set bin in place and level, by adjusting the levelers built into each leg. In the event that installation is such that legs can't be used, screw out the four legs and use shims to level the cabinet. The National Sanitation Foundation requires that a cabinet not on legs must be sealed to the floor using mastic around the entire perimeter of the bottom of the bin.

LEVELING ICE CUBER

After cuber is in place and all electrical and water supply and water drain connections have been completed, level the ice cuber by adjusting the levelers built into each 6 inch & 12 inch leg.

SERIAL AND ELECTRICAL PLATE

The combined serial and electrical plate is located inside of the ice cuber above the water pump. Be sure to have the complete serial and model numbers when calling for parts or service.

REMOVING FRONT PANEL

To remove front panel, (Fig. 1) pull forward on lower edge of panel and lift panel up and off. To install panel, set top of panel on edge at the top of head unit and snap into place at bottom.

REMOVING HEAD SECTION PANELS

The top and both sides of the cuber head unit is a one-piece construction. To remove this wrap-around panel, remove the three screws (Fig. 2) along the lower edge and the two screws (Fig. 2) on the back edge on each side of head unit. Lift the entire panel (Fig. 2) forward to remove. This will expose both the ice making and machine section of the cuber.

ELECTRICAL CONNECTIONS		Min. Circuit Amps	Max. Circuit Fuse
115 Volt — 60 Cycle — 1 Phase	Air Cooled	18A	25A
	Water Cooled	16.8A	25A
230 Volt — 50 Cycle — 1 Phase	Air Cooled	9A	10A
	Water Cooled	8.5A	10A

GENERAL REQUIREMENTS

All electrical and water supply and drain connections must conform to local codes.

CONNECTING POWER SUPPLY From rear of cuber place separately fused wire into hole (Fig. 14) in back panel. Run wire across machine section and into the hole at lower portion of electrical control box (Fig. 4 "C").

From front of machine, remove the cover from electrical control box (Fig 3). Connect lead wires with the two lead wires supplied in control box leading to N (neutral) and L₂(line 2). Use No. 20 Ampere Fusetrons only, as all 60 cycle circuits are 115 volt, necessitating a neutral in the supply line.

WATER SUPPLY

Quality and ice making capacity are affected more by chemistry, temperature, and foreign matter in supply water than any other factor. A survey made of water departments of large cities all over the country made it obvious that external filters or strainers should be installed. Such equipment is very effective in improving ice quality and reducing the frequency of cleaning out the ice making section. Any questions as to the type of water filter or strainers to be used can be answered by your local water treatment company or water department.

CONNECTING WATER SUPPLY A 1/2" female pipe fitting is provided in the rear panel of the head unit. (Fig 14) Install the water filter screen provided with the cabinet. Use 3/8" O.D. copper tubing for the water supply.

DRAIN CONNECTIONS

It is essential that drain connections be made so waste water cannot back up into the head unit or bin. On water cooled models, a separate connection is provided for discharging condenser water. (Fig. 2 & 14). All connections are labeled. We recommend covering all incoming water and drain lines with a plumbing insulation material to prevent condensation. If the head unit and bin drains are tied together through a "T" connection, we recommend using a 3/4" pipe and a stand pipe vented to the atmosphere to prevent water traps. Drains must be at least 1/2" inside diameter and have 1 1/2" drop per 5 feet of run. If drains are not close enough to allow drop for proper drainage, or water is to be drained in a stationary sink higher than ice machine drains, use an automatic condensate disposal pump. (Check and follow local plumbing codes.)

CHECK LIST FOR STARTING MACHINE

- Remove tape securing the damper door, splash curtain, water pump, and float valve.
- Remove the shipping block from beneath the compressor.
- Remove water pump enough to remove the corrugated packing protecting the pump during shipment.

Turn on water, and observe that the float valve shuts off the water when the level is about 2 inches deep. Should float require adjustment merely bend float rod carefully until desired water level is achieved. Turn the toggle switch to "water pump", left position.

The water pump will start pumping water into the tube located at the top of the evaporator. Return water will flow into the sump.

FINAL CHECK LIST

1. Is cuber level? (IMPORTANT)
2. Water level in sump trough should be as high as possible so water pump does not suck in air, but not too high a water level so the water does not overflow the elbow during freeze cycle and reduces ice making capacity.
3. Turn the ice cuber on and off several times to flush clean water through the system and to observe that waste water drains properly.
4. Check water distributor tube above evaporator and see that it is distributing the water properly and evenly over the front of the evaporator. See Fig. 8.
5. Check all refrigerant and conduit lines to guard against vibrations and possible failure.
6. Turn toggle switch to ice making position. Reach down in to ice chute and push damper door open. Entire ice cuber should stop until damper door is released and cuber should start up again. The cuber should shut off when the damper door is approximately 1" open.
7. Has owner been instructed on how to operate and clean the cuber?

8. Has installation and warranty registration card been filled out? This is for owner protection.
9. Is there 5" clearance around cuber for proper air circulation?
10. Does room maintain a minimum of 55° F during winter months in order to produce ice as per ice production specifications on Page 22?
11. Check water and drain connections for water leaks.
12. The ice size controls consist of a pressure control (opens on pressure rise) and a solid state time clock. These controls are factory set and should need none or very little adjustment.
13. Installer should replace control box cover and front panel. Cuber should be checked for two or three harvest of cubes to see that cuber functions properly.

MANITOWOC FREEZE & HARVEST CONTROL FOR 400 SERIES MODELS AR-AD-AY.

Freeze and harvest cycles on the above model Manitowoc ice cubers are regulated by three very simple controls. The basic control is a low side reverse acting pressure control made by either Ranco or Penn. This is mounted on the compressor compartment bulkhead which separates this area from the freezing section. (See Fig. 5) The second control is solid state timer located in the control panel of the freezing compartment. (See Fig. 16) The third is the bin door micro switch located in the base of the control box. (See Fig. 16) With the main toggle switch in the ice position the compressor, water pump, and fan motor will operate. The suction pressure during the freeze cycle will start at approx. 20 PSIG and drop to approx. 7-8 PSIG. When the suction pressure reaches (9 PSIG regular cube, 11 PSIG dice cube, or 12 PSIG half dice cube) the reverse acting low pressure control will close its contacts energizing the solid state timer delay circuit through terminal "1". The timer delay period is adjustable and is used to set the desired bridging between the ice cubes. (See Figs. 11-13) At the end of the timing sequence the timer relay will energize, shutting off the water pump and fan motor, and energizing the hot gas solenoid valve. The suction pressure will rise well above 30 PSIG during the harvest cycle. The low pressure control will open its contacts and the timer relay will remain energized through the timer interlock circuit. The cuber will remain in harvest until the ice slides loose from the evaporator and falls through the ice chute tripping the damper door and momentarily opening the bin micro switch. The bin micro switch will momentarily de-energize the entire cuber, the timer relay will return to its normal position, de-energizing the hot gas solenoid valve and energizing the water pump and fan motor. The cuber is now in a new freeze cycle. The cuber will continue to cycle until the bin fills with ice holding the damper door open, which in turn holds the bin micro switch open shutting the cuber off.

CONTROLS

High Pressure Cut-out Fig. 4

The high pressure cut-out shuts off the entire ice cuber, should the head pressure exceed 275 PSIG. If cuber goes out on high head pressure the high pressure cut-out control has to be manually reset after the cause of the high head pressure has been corrected.

High pressure cut-out used on both water & air cooled models.

Suction Line Thermo Disc

Suction line thermo disc is a safety control located on suction line. This control is a Klixon switch that opens at 65° F + -5°, and closes at 35° F + -5°. The thermo disc acts only as a safety device to prevent overheating of the machine. Should the damper door switch fail after harvest, the thermo disc will open. When the suction line temperature reaches 65° + -5° this will return the machine to its normal freezing cycle by de-energizing the timer lock in relay.

Toggle Switch Fig. 4

The main power "ON and OFF" toggle switch is a double pole, double throw switch with "OFF" in the center position. With the toggle switch in the "water pump" (Left) position, only the water pump

and the condenser fan operate. This is for checking the water inlet float level, pump operation, and for circulating cleaning solution.

With the toggle switch in the "ICE" (Right position, the water pump, compressor, and condenser fan (air cooled models), run for a normal ice making cycle.

Ranco or Penn Pressure Control Fig. 5

This control is a reverse-acting pressure control that opens on pressure rise. Upon decrease in suction pressure (11 lb. on dice cubers, 12 lb. on half dice cuber, 9 lb. on regular cubers) the pressure control closes, actuating the time cycle on the solid state timer.

A lower setting on the control will produce a heavier bridging between cubes, a higher setting thinner bridging between cubes. This control activates solid state timer, which then takes over balance of freezing cycle.

Water Pump Fig. 3 & 15

Recirculating pump used to pump supply water to water distributor tube located above the evaporator assy. To disassemble the water pump for cleaning and to remove the stainless steel mounting bracket and pump cover see Page 14.

Bin Damper Door Switch Fig. 4

This switch is activated by bin damper door rod counter weight. When bin is full of ice the sheet of ice cubes will not clear the ice chute and will hold bin damper door open allowing bin damper door switch to open, shutting off entire ice cuber. When sheet of ice cubes is allowed to clear the ice chute the bin damper door will be allowed to close. This allows the bin damper switch to close starting up the ice cuber again putting it into next freeze cycle.

Hot Gas Solenoid Defrost Valve Fig. 5

Hot gas solenoid is closed during the cuber freeze cycle. When time cycle on solid state timer has elapsed the hot gas solenoid valve is open. The water pump and condenser fan motor on air cooled models will stop. Cuber is now in hot gas defrost cycle.

Solid State Timer Fig. 4-9-10-11-12-16

When suction line pressure has dropped low enough the low pressure control will close activating the time cycle of the solid state timer. The length of the time cycle is adjusted as shown in Fig. 12. When the time cycle has elapsed the timer will energize its own lock-in relay, cycling the ice cuber into hot gas or harvest cycle. Simultaneously, the water pump (and condenser fan on air cooled models) are shut off.

The length of the harvest is controlled by the time it takes the ice to fall through the ice chute tripping the bin damper switch. Fig. 3 & 4.

NOTE:

The Model A0400 ice cubers were manufactured with different make solid state timers. See Fig. 10 & 11. These timers are interchangeable with one another. Should it be necessary to have to replace one with the other the wiring will be the same. The only thing to make sure of is that the numbered wires are placed on the terminals with corresponding numbers.

Setting Solid State Timer

Should it be necessary to adjust the timer for an accurate bridge thickness, proceed as follows:

1. Remove front cover on control box Fig. 3.
2. Locate timer Fig. 4.
3. Adjust freezing time as per instructions in Fig. 11-12-13.

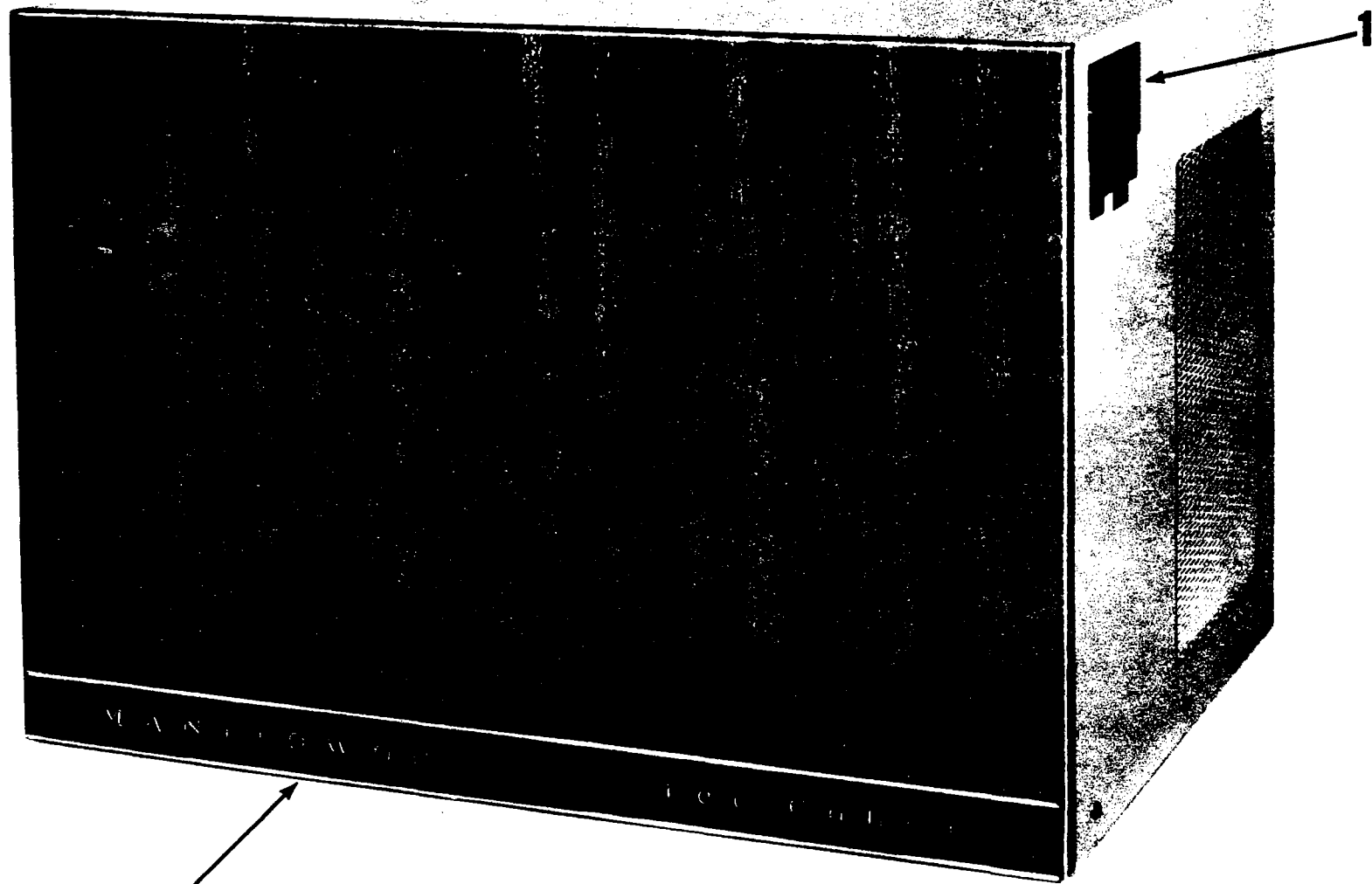

FIG. 1

1. Serial & Electrical Plate
2. Front Panel Assy.
3. Front Panel Trim & Nameplate

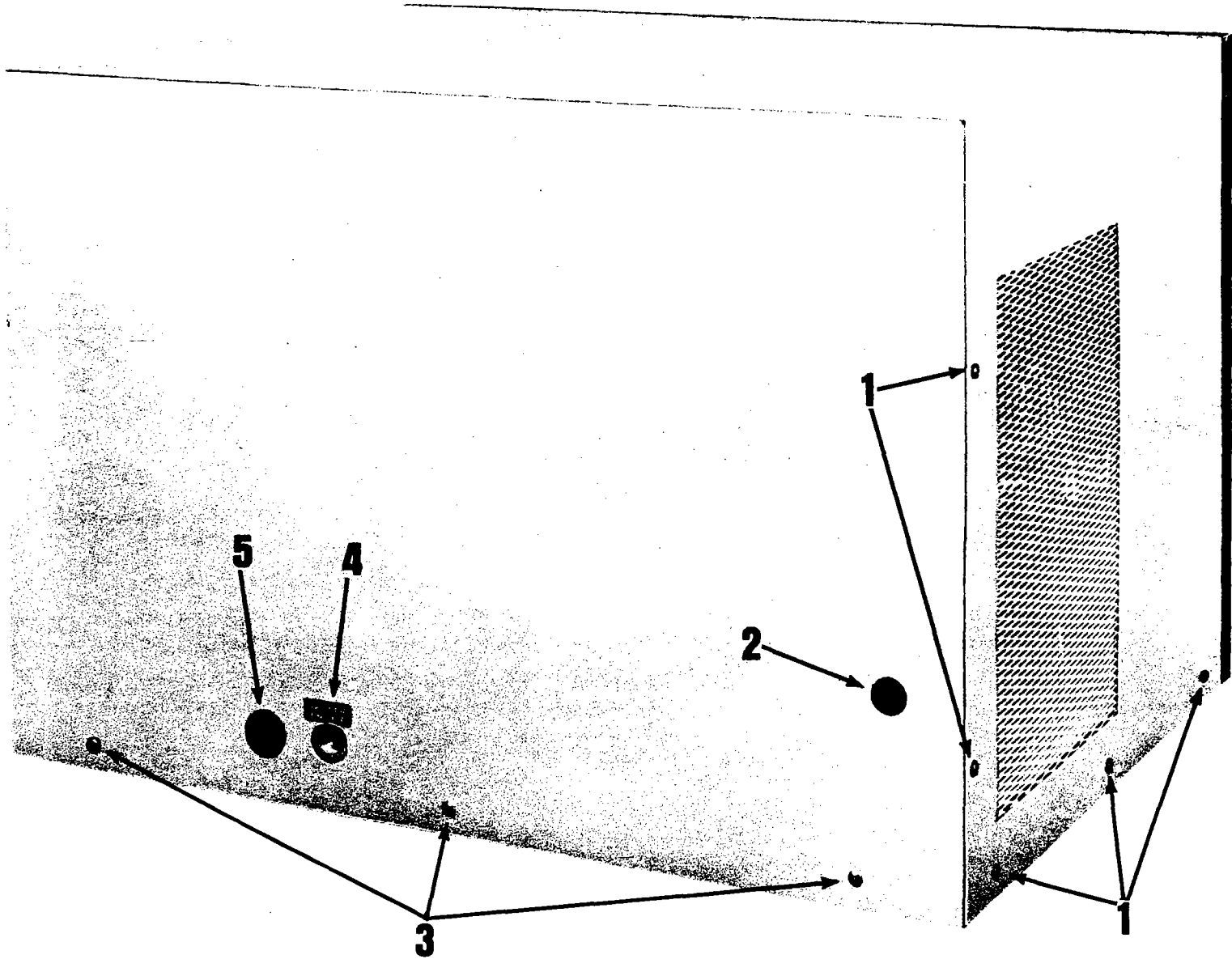

FIG. 2

- 1. Outer wrapper panel mtg. screws.
- 2. Electrical power supply opening.
- 3. Rear panel mtg. screws.
- 4. Fresh water inlet supply.
- 5. Opening for water condenser drain (used on water cooled models only)

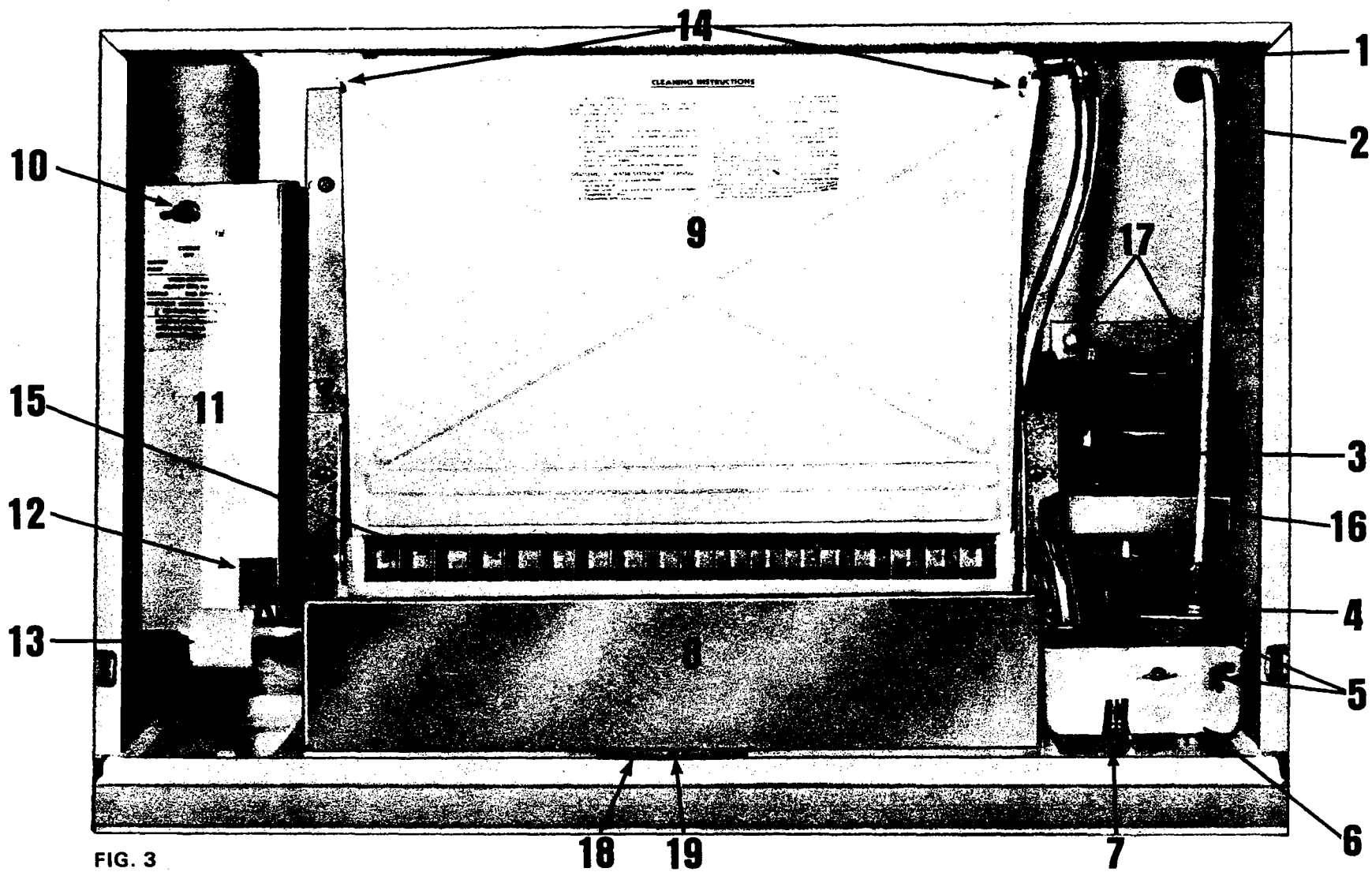

FIG. 3

- 1. Water inlet supply tube & elbow assy. (from water pump to water distributor tube)
- 2. Fresh water supply tube to float valve.
- 3. Water pump assy.
- 4. Float valve.
- 5. Float valve mtg. bracket & mtg. wing nuts.
- 6. Sump trough assy.
- 7. Sump trough water level tube (water overflow tubes)
- 8. SS ice chute.
- 9. Evaporator water splash curtain.

- 10. Main toggle switch.
- 11. Control box front cover.
- 12. Damper door micro switch
- 13. Damper door & counter wt. assy.
- 14. RH & LH water curtain hooks.
- 15. Evaporator assy.
- 16. Water pump bracket.
- 17. Water pump brass mtg. studs.
- 18. Ice chute mtg. clip.
- 19. Ice chute mtg. screw.

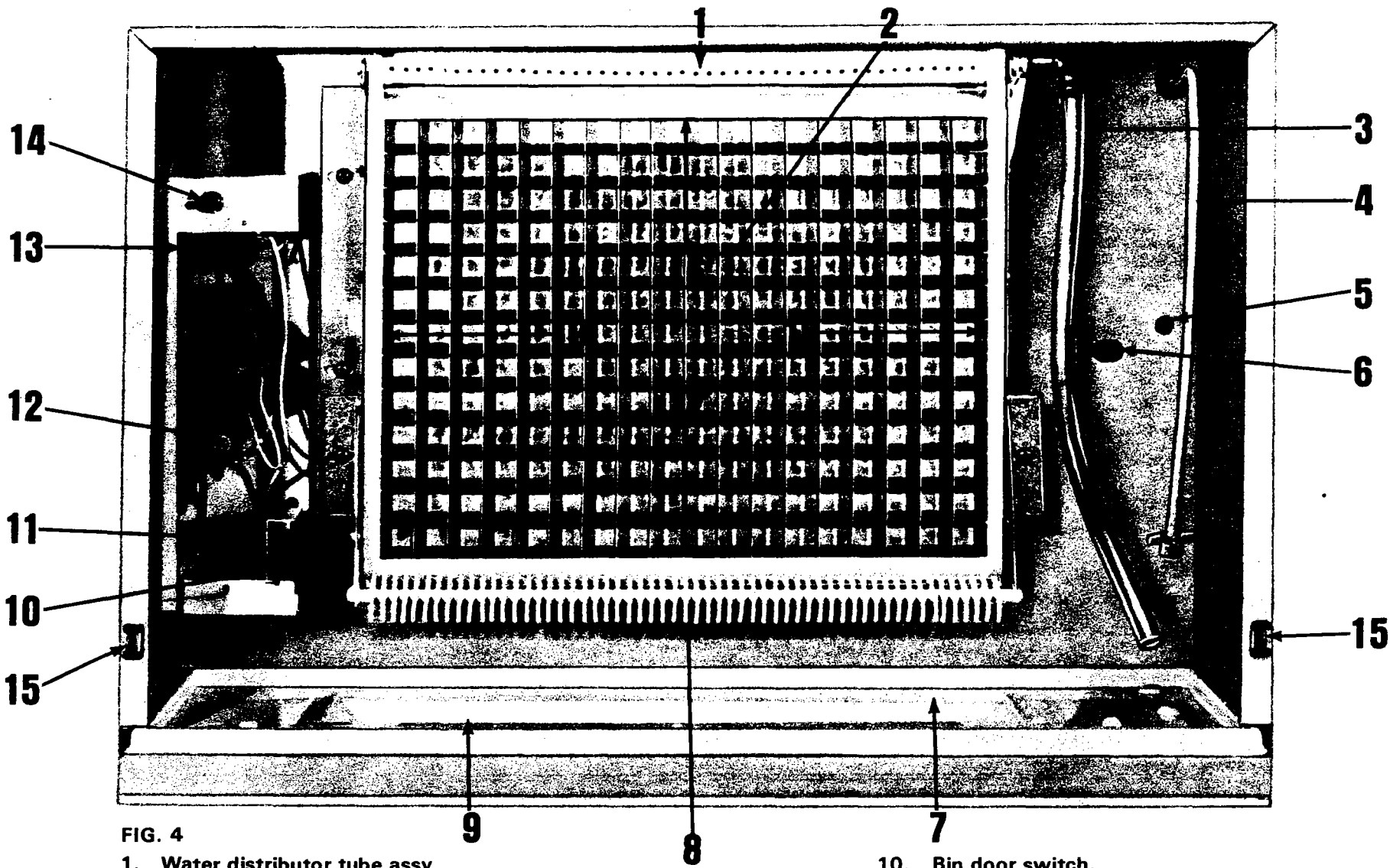

FIG. 4

- 1. Water distributor tube assy.
- 2. Evaporator assy.
- 3. Water supply tube & elbow assy. (from water pump to water distributor tube assy.)
- 4. Fresh water inlet to float valve assy.
- 5. Water pump brass mtg. stud.
- 6. Water pump electrical outlet.
- 7. Base drain opening.
- 8. Harvest rack.
- 9. Ice chute opening.

- 10. Bin door switch.
- 11. Elect. opening into control box.
- 12. Timer.
- 13. High pressure cut-out.
- 14. Main toggle switch.
- 15. Front panel catch.
- 16. Top evaporator grid extrusion.
- 17. Bottom evaporator grid extrusion.
- 18. RH evaporator grid extrusion.
- 19. LH evaporator grid extrusion.

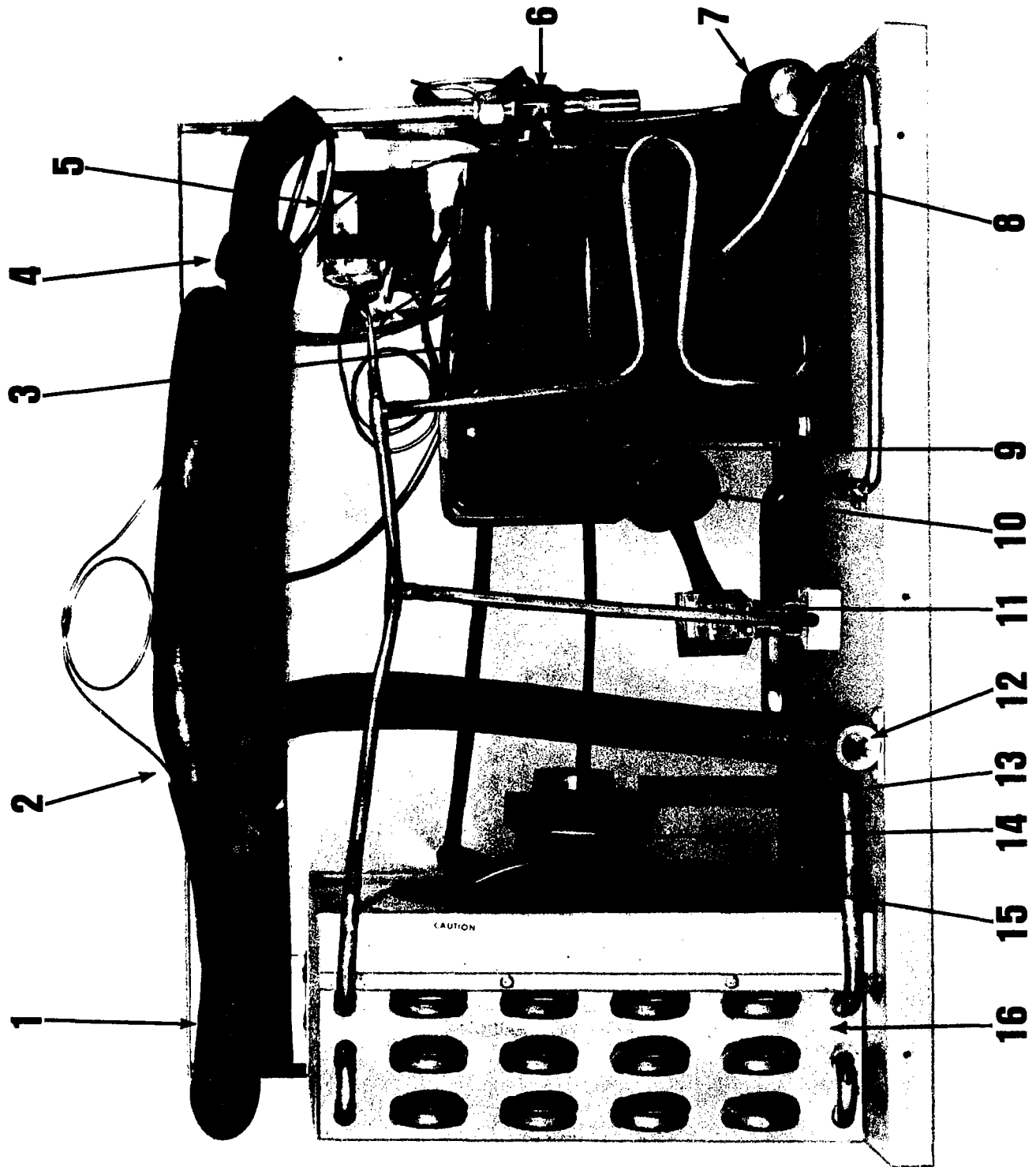

FIG. 5

- | | |
|--|---|
| <ul style="list-style-type: none"> 1. Suction line assy. 2. Expansion valve capillary tube & bulb. 3. Compressor. 4. Thermodisc 5. Low pressure cut-in control. 6. Low side service valve. 7. Drier. 8. High side processing tube. | <ul style="list-style-type: none"> 9. Compressor overload & relay junction box. 10. Capacitor assy. (start) 11. Hot gas solenoid valve. 12. Fresh water inlet. 13. Fan motor bracket. 14. Fan motor. 15. Fan blade. 16. Air cooled condenser. |
|--|---|

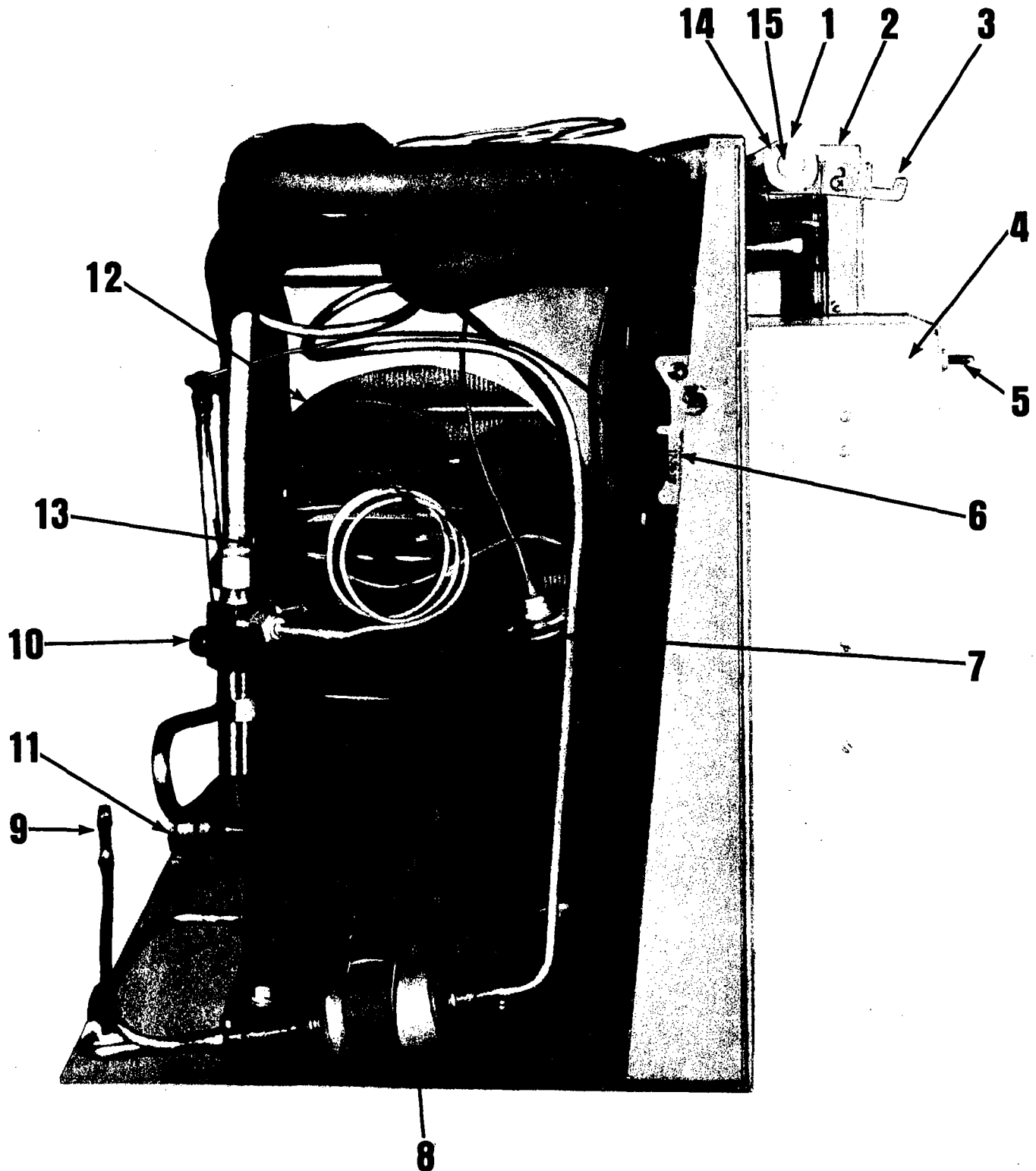

FIG. 6

- | | |
|---------------------------------|---|
| 1. Water distributor tube assy. | 8. Drier. |
| 2. Evaporator assy. | 9. High side processing tube. |
| 3. Water curtain hanger LH. | 10. Low side service valve. |
| 4. Control box. | 11. Fresh water inlet. |
| 5. Main toggle switch. | 12. Fan blade. |
| 6. Low pressure cut-in control. | 13. Compressor assy. |
| 7. Expansion valve. | 14. Water distributor tube end collar (2 per) |
| | 15. Water distributor tube end plug (1 per) |

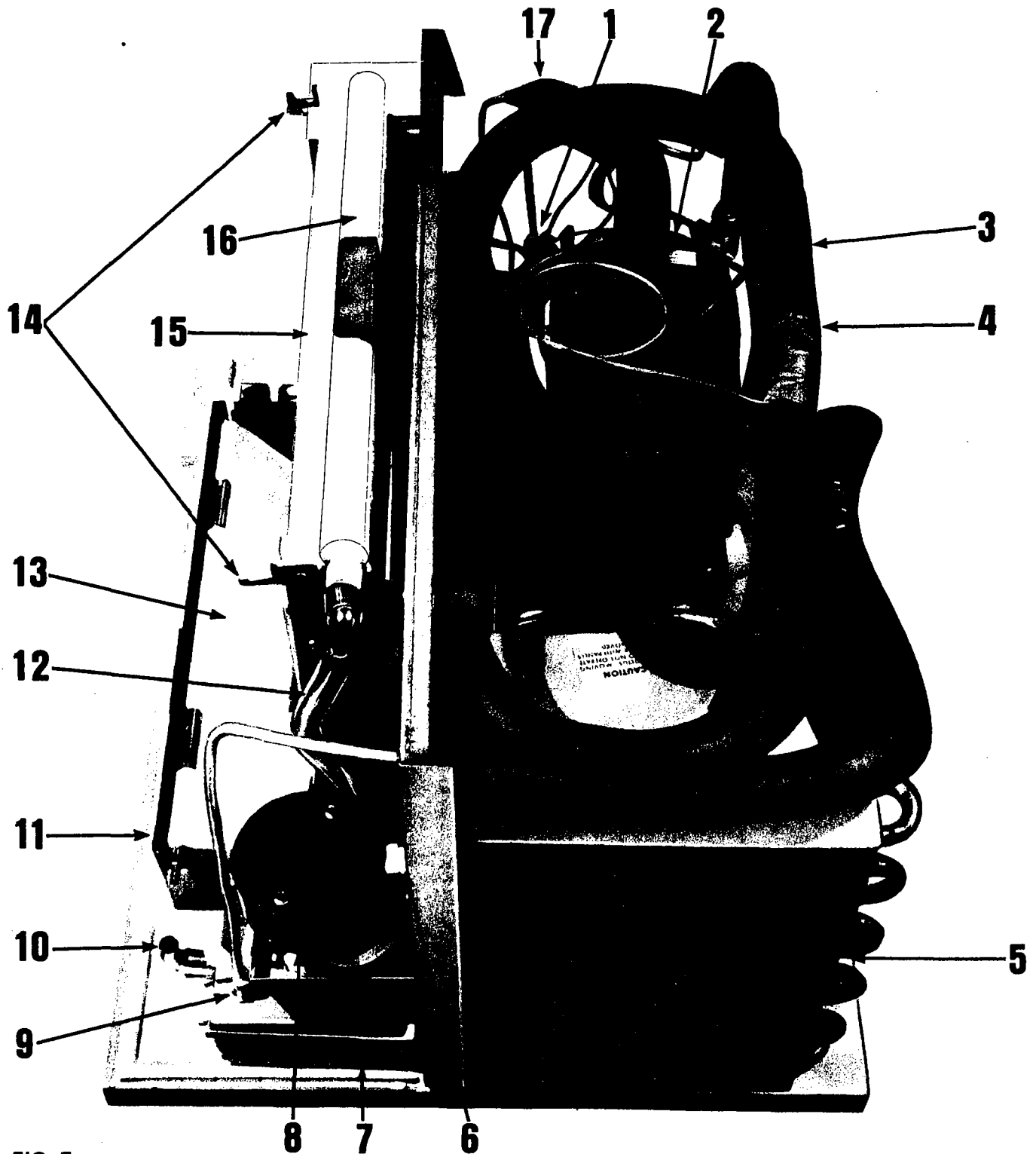
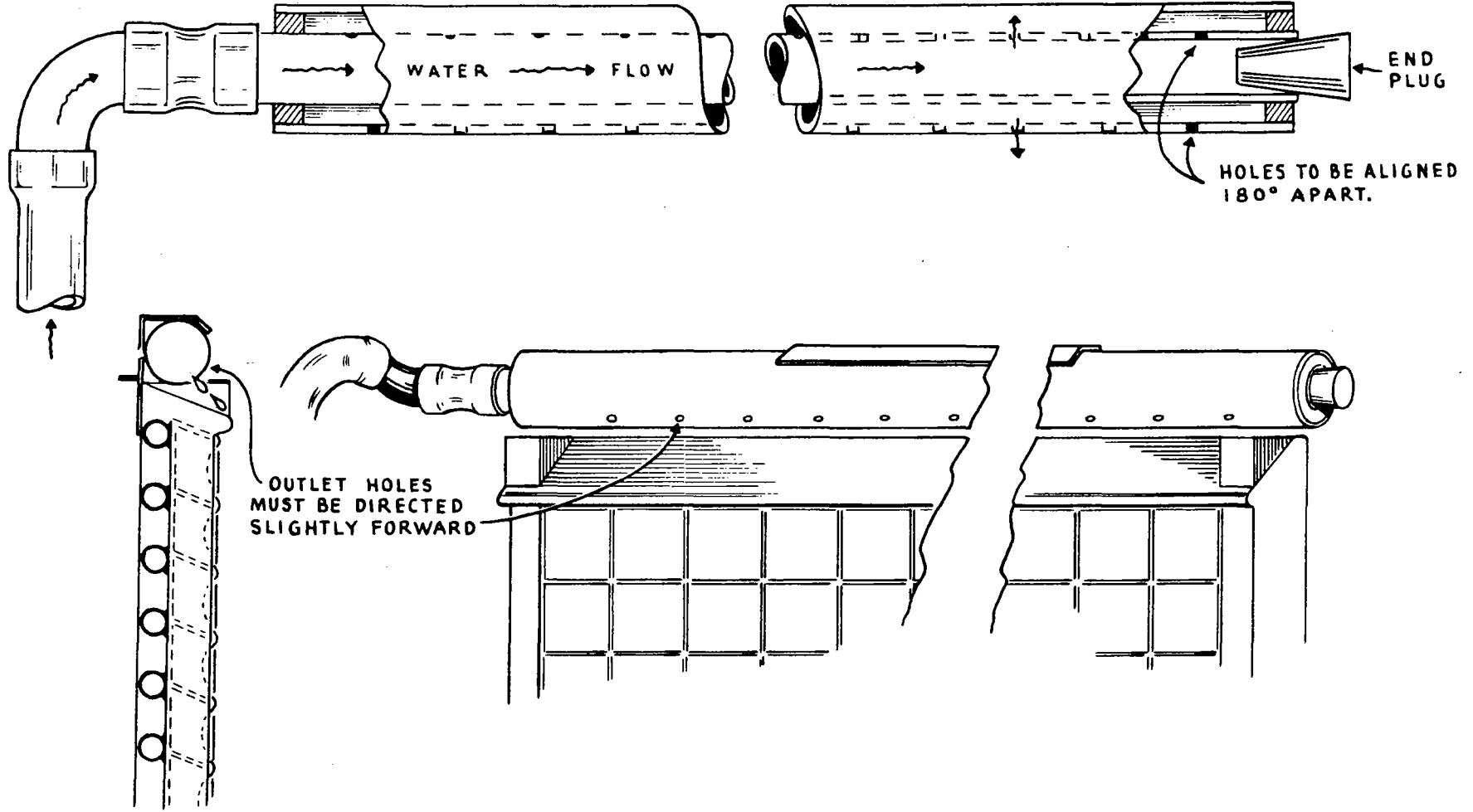

FIG. 7

- | | |
|--|---|
| <ul style="list-style-type: none"> 1. Expansion valve. 2. Compressor. 3. Suction line assy. 4. Expansion valve bulb location. 5. Air cooled condenser. 6. Water pump electrical plug. 7. Sump trough assy. 8. Water pump & bracket assy. 9. Float valve & bracket assy. | <ul style="list-style-type: none"> 10. Sump trough overflow tube assy. 11. Ice chute assy. 12. Water supply tube & elbow (from water pump to water distributor tube assy.) 13. Damper door & counter wt. assy. 14. Water curtain hangers LH & RH. 15. Evaporator assy. 16. Water distributor tube assy. 17. Thermodisc. |
|--|---|



WATER SYSTEM SKETCH
FIG. 8

WATER PUMP ASSEMBLY

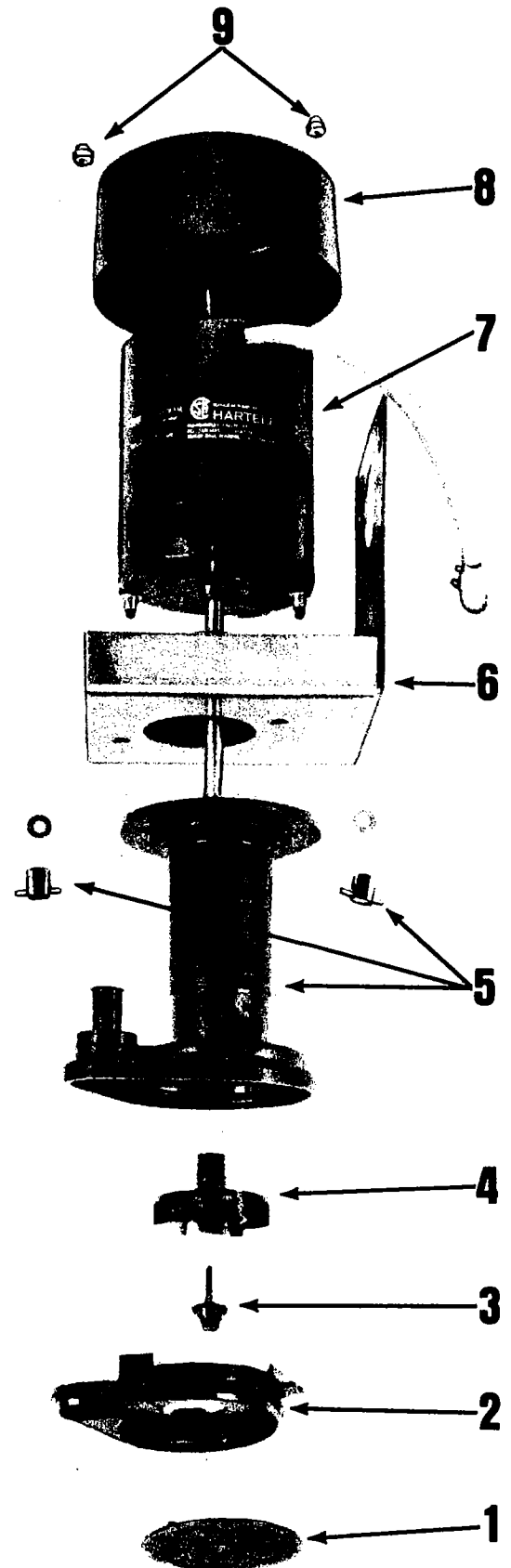
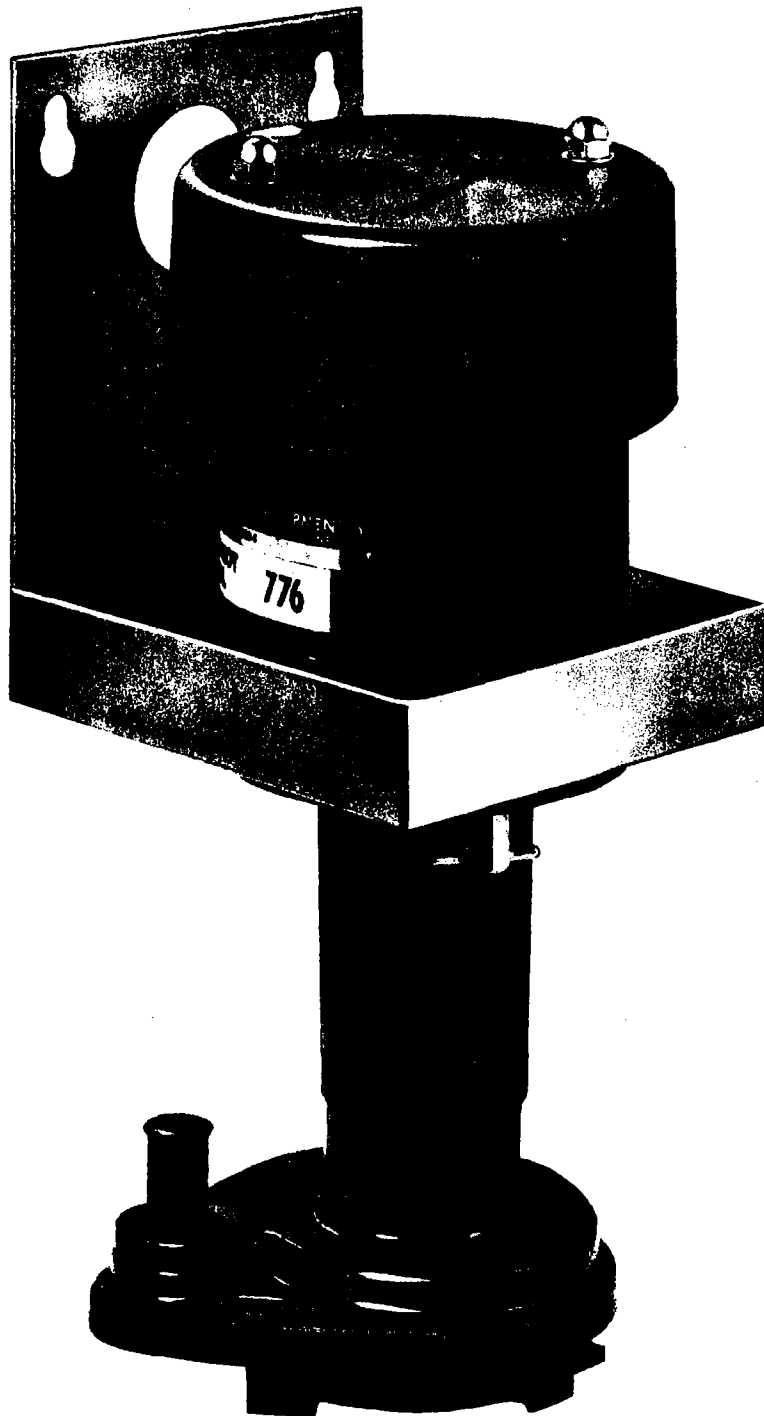

FIG. 15

1. Inlet screen
2. Impeller housing
3. Impeller thumb nut
4. Impeller
5. Motor shaft housing & mounting nuts
6. Pump bracket
7. Pump motor
8. Pump cover
9. Cover mounting nuts

Water pump is available as a complete pump assembly less cover & bracket.
 Motor not available separately.

**CONTROL BOX ASSEMBLY**

FIG. 16

1. Main toggle switch.
2. High pressure cut-out and manual reset switch plunger.
3. Terminal board.
4. Solid state timer.
5. Bin door micro switch.

MIDTEX SOLID STATE TIMER

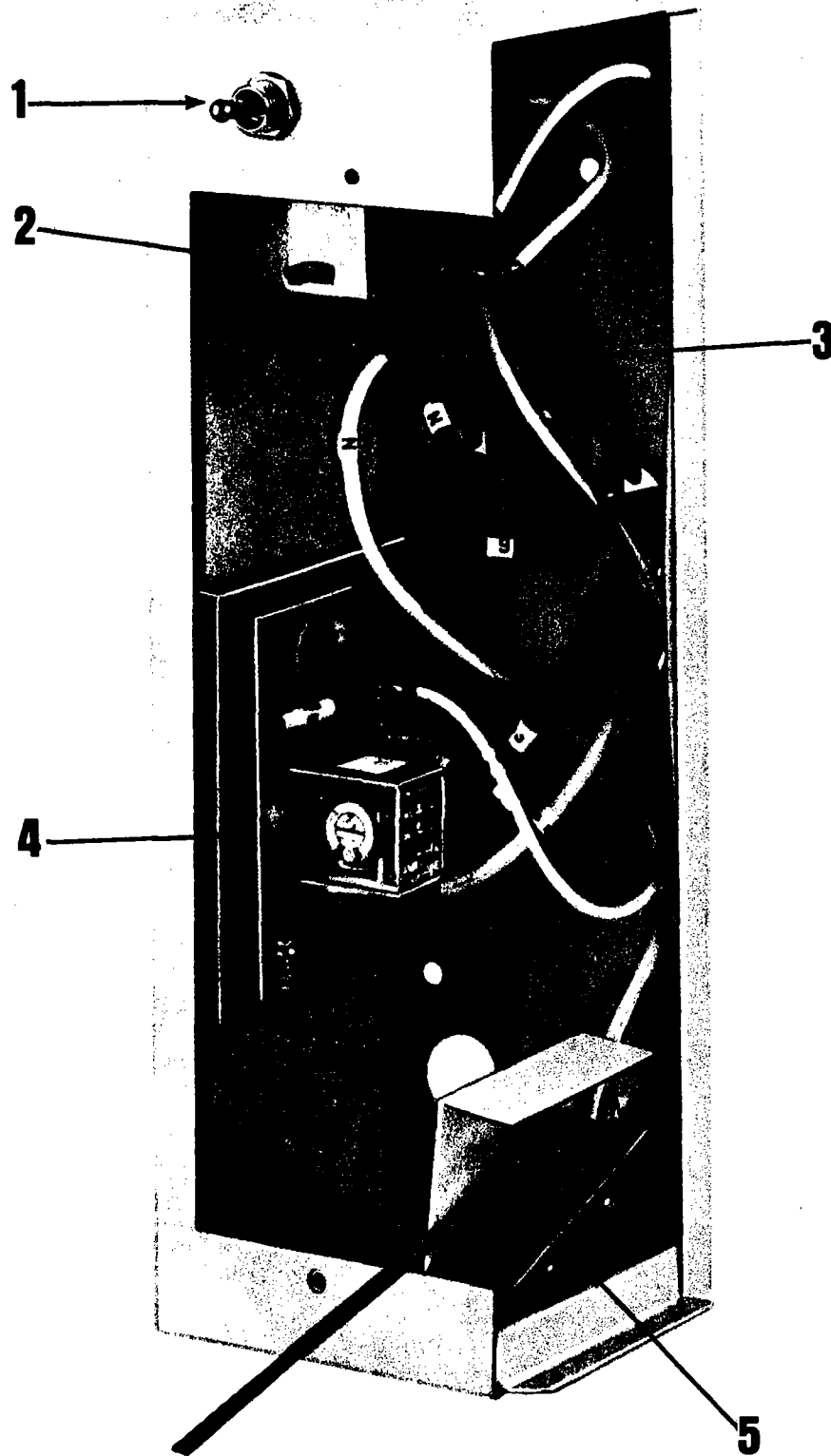
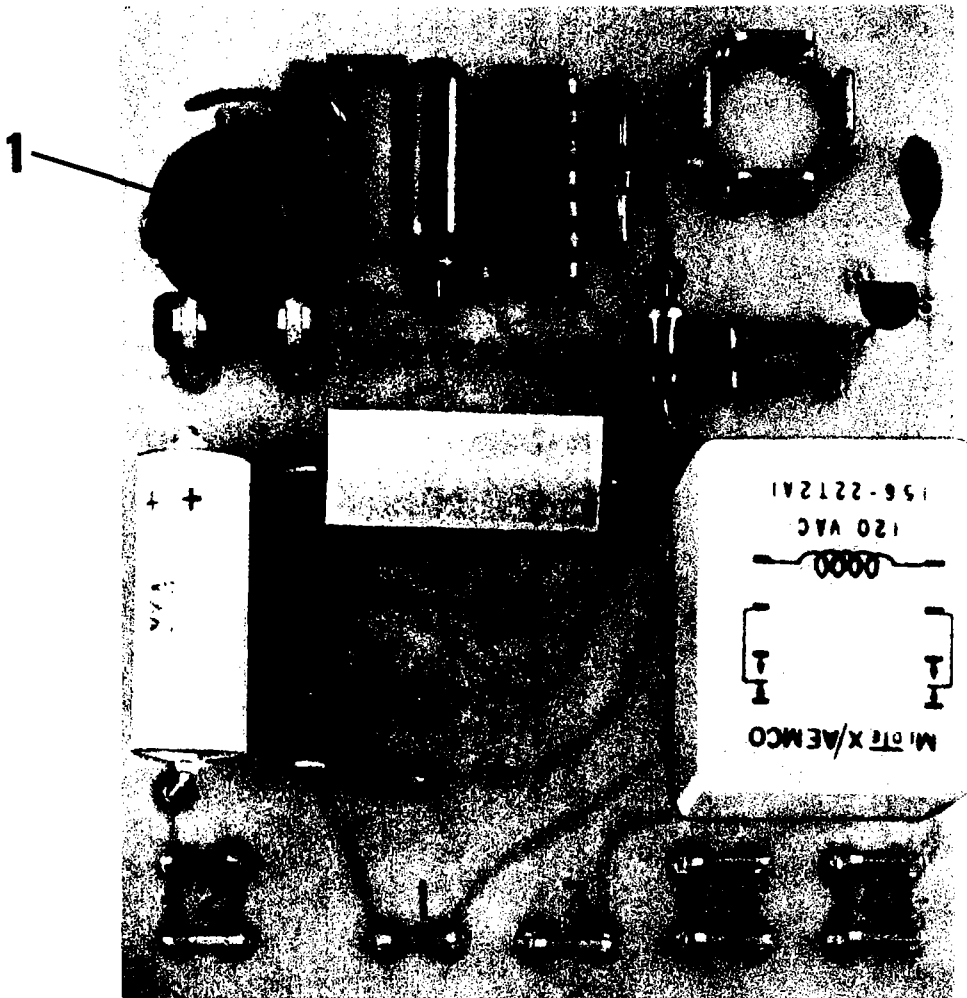

FIG. 9

1. Timer adjustment dial

OMNETICS SOLID STATE TIMER

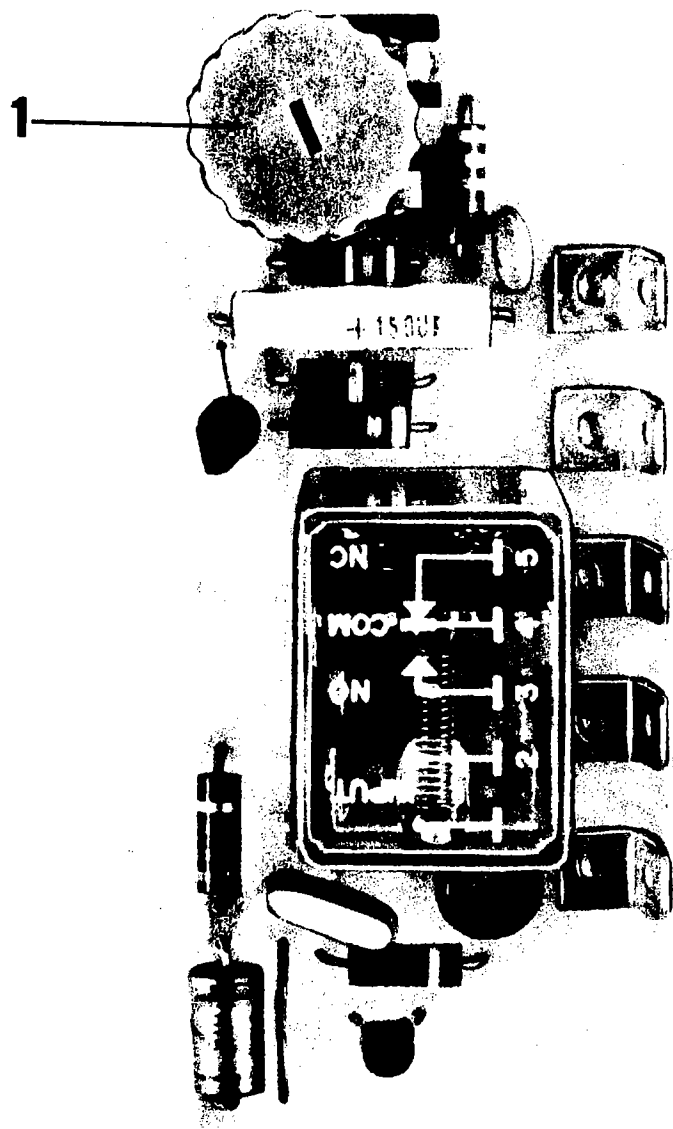
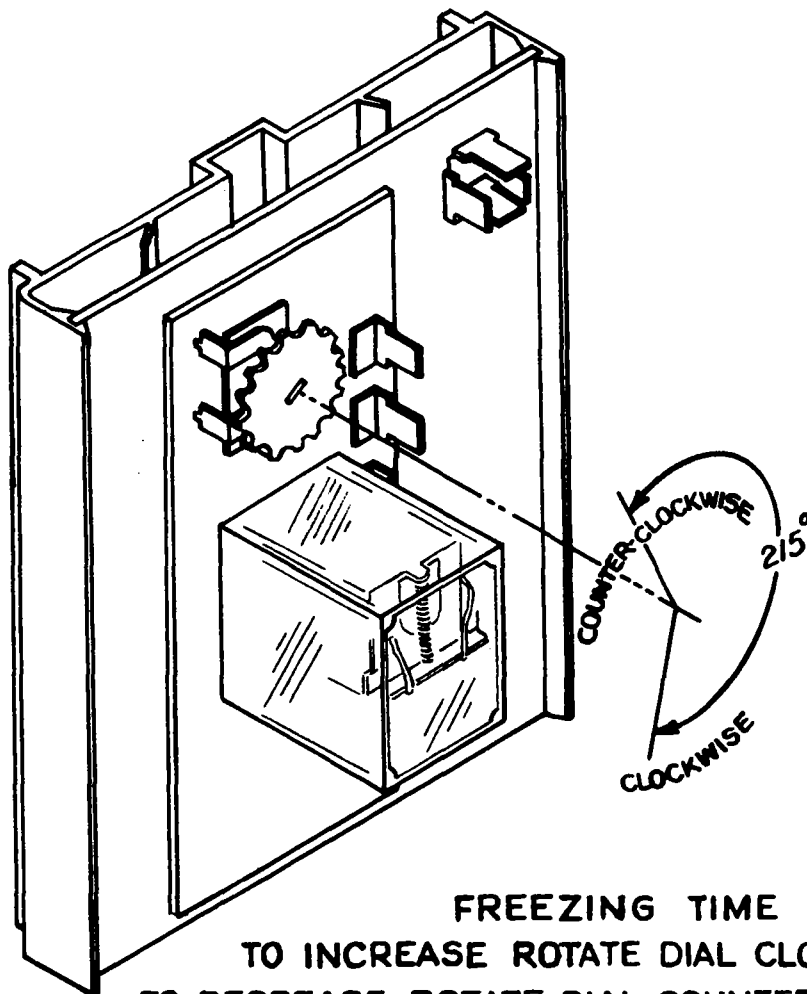

FIG. 10

- 1. Timer adjustment dial



FREEZING TIME
TO INCREASE ROTATE DIAL CLOCKWISE
TO DECREASE ROTATE DIAL COUNTER-CLOCKWISE
(MAX. ADJUSTMENT APPROX. 10 MIN. 215° TURN)
¼ TURN EQUAL APPROX. 5 MIN.

SOLID STATE
OMNETICS TIMER
SETTING INSTRUCTIONS

MIDTEX TIMER SETTING INSTRUCTIONS

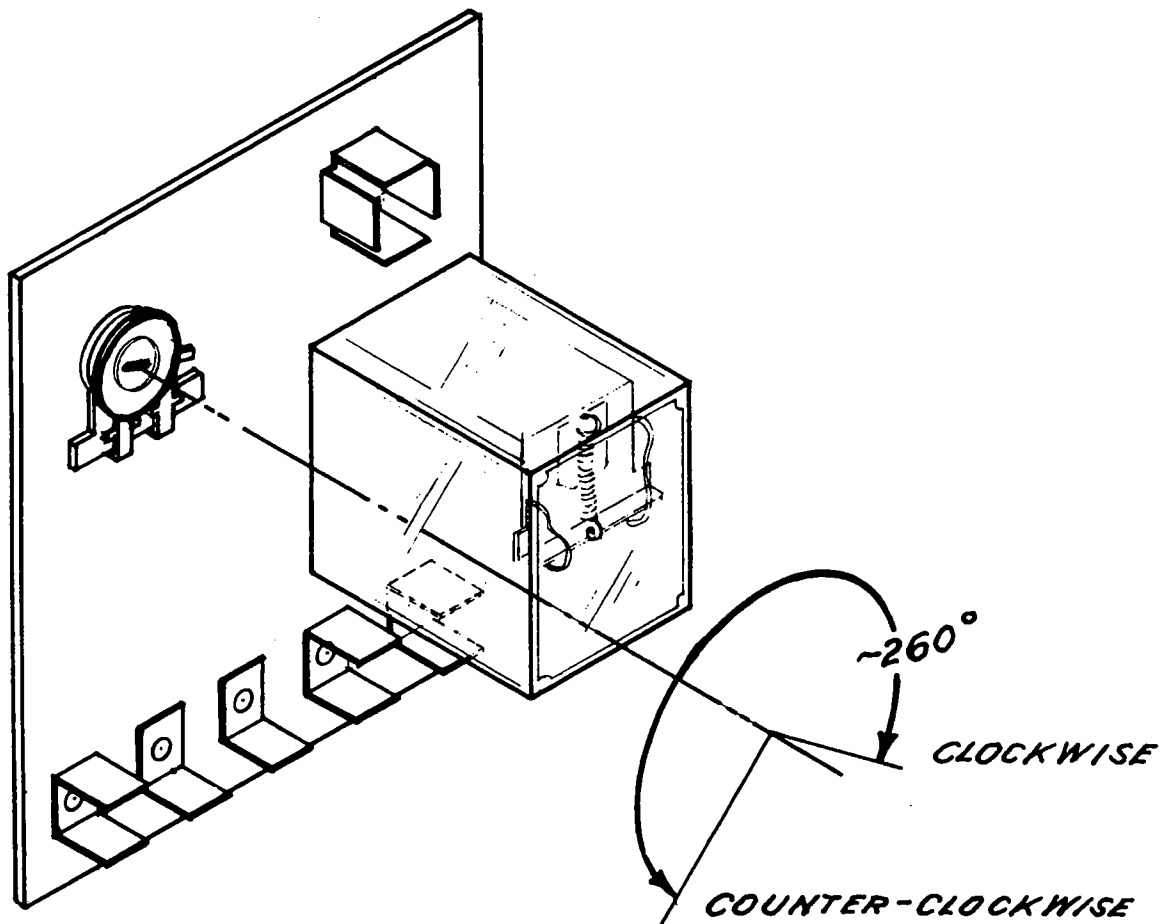

FREEZING TIME

TO INCREASE, ROTATE DIAL CLOCKWISE
TO DECREASE, ROTATE DIAL COUNTER-CLOCKWISE
(MAX. ADJUSTMENT APPROX. 15 MIN. 260° TURN)
 $\frac{1}{4}$ TURN EQUAL APPROX. 5 MIN.

FIG. 12

FOR OPTIMUM ICE PRODUCTION AND MAXIMUM CUBE SEPARATION, THE ICE CONNECTING THE INDIVIDUAL CUBES SHOULD BE 1/8 INCH THICK AT THE CENTER OF THE ICE "WAFFLE."
(NOTE: BRIDGING WILL VARY IN THICKNESS FROM TOP TO BOTTOM OF EVAPORATOR)

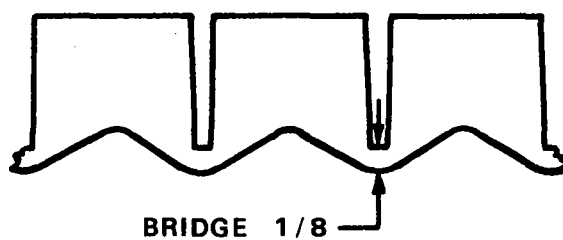

FIG. 13

Ice Production — Lbs. per 24 Hours

"400" SERIES ICE PRODUCTION (Pounds per 24 Hours) *	Incoming Water Temperature F		Room Temperature F		
			70°	80°	90°
	Air Cooled Models	50° 70° 90°	330 290 250	300 260 220	270 230 190
Water Cooled Models	50° 70° 90°	380 340 300	370 330 290	360 320 280	

* Approximate production for Dice Cube and Half Dice Cube. Regular Cube production slightly lower.

CONDENSER WATER CONSUMPTION			
Incoming Water Temperature of	50°	70°	90°
Gals./24 Hr. Running Time	260	500	1450

Specifications

"400" SERIES MODELS	Cube Type	Condenser	Exterior Finish	Approx. Ship. Wt. — lbs.
AR-0400A	Regular	Air	Fawn	232
AR-0400AS	Regular	Air	Stainless	232
AR-0401W	Regular	Water	Fawn	221
AR-0401WS	Regular	Water	Stainless	221
AD-0402A	Dice	Air	Fawn	234
AD-0402AS	Dice	Air	Stainless	234
AD-0403W	Dice	Water	Fawn	233
AD-0403WS	Dice	Water	Stainless	233
AY-0404A	Half Dice	Air	Fawn	233
AY-0404AS	Half Dice	Air	Stainless	233
AY-0405W	Half Dice	Water	Fawn	234
AY-0405WS	Half Dice	Water	Stainless	234

DIMENSIONS (All MODELS): Height 20-5/16" — Width 30" — Depth 23-9/16".

ELECTRICAL CHARACTERISTICS: 115 VAC — 60 Hertz single phase.
220 VAC — 50 Hertz single phase available on special order.

COMPRESSOR: 1/2 horsepower, 4600 B.T.U. per hour rating.

Bin Specifications

"400" SERIES BIN OPTIONS	C-170	C-400	C-610 *	C-900 *
Ice Storage * * — lbs.	220	430	580	1040
Height — inches	19-1/32	31-3/8	31-7/16	44
Width — inches	30	30	48	48
Depth — inches	28	34	29-9/32	34
Approx. Ship. Wt. — lbs.	65	116	163	230
Carton Volume — cu. ft.	12.5	24	32.5	49

NOTES . . . Bin Legs are cast aluminum. No. 606 Adjustable from 6-1/2" to 7-1/2" — No. 612 Adjustable from 12" to 13-1/2".

* E-302S Bin Adapter.

** Rated storage capacity is based on 35 lbs. per cubic foot at 90% of internal volume.

INSTALLATION . . . For both air and water cooled machines allow a minimum of 5 inches clearance on both sides and a minimum of 5 inches in back. Minimum Ampacity 18 Amps.

SERVICE . . . All panels are removable for immediate access to electrical, refrigeration, and ice making components. Cleaning can be done in minutes by disassembly, or using the water pump to circulate approved liquid ice machine cleaner.

WARRANTY . . . One year from date of installation on all parts. Four year additional compressor warranty at no additional cost. (For details see "Ice Machine and Bin Warranty".)

SERVICE ANALYSIS

<u>COMPLAINT</u>	<u>CAUSE</u>	<u>CORRECTIVE MEASURES</u>
Slow harvest	Contaminated or limed water system Low ambient (air cooled models) Water valve set too low	Clean water system Must be above 50° F Adjust water valve to 125 PSIG head pressure (Water cooled models) Replace water valve
	Leaking water valve (water cooled models)	
High head pressure	Air in system	Evacuate and recharge
	Defective water valve (water cooled models)	Replace water valve
	Defective fan (air cooled models)	Replace fan
	Water valve not properly adjusted (Water cooled models)	Adjust water valve
High suction pressure	Contaminated air cooled condenser	Clean condenser
	Defective expansion valve	Replace
	Defective fan	Replace fan
High suction pressure	Defective water valve (water cooled models)	Replace or adjust water valve
	Moisture in system	Replace drier, evacuate and recharge
	Contaminated condenser	Clean
Low suction pressure	Shortage of refrigerant	Locate leak and repair
	Moisture in system	Replace drier, evacuate system
	Ambient too low for operation	Must be above 50° F
Unit noisy	Tubing touching each other	Separate tubing so it does not touch
	Fan shroud touching fan blades	Adjust fan mounting brackets
	Loose fan blade	Tighten fan blade
Ice maker will not stop when full of ice	Damper door not properly adjusted	Adjust damper door
	Defective damper door micro switch	Replace damper door micro switch
Timer will not operate	Pressure control not closing	Replace control or properly adjust
	Low pressure not low enough	Replace expansion valve
	Timer defective	Replace timer
	Thermo disc is not closed	Check thermo disc
Small cube bridge	Pressure control not opening	Replace control
	Leak in refrigeration system	Locate leak, repair, evacuate and recharge.
Machine will not cycle into harvest	Defective time clock	Replace
	Defective thermo disc or thermo disc loose on suction line	Replace or tighten on suction line
	Bad hot gas valve	Replace valve
	Bad low pressure cut-in	Check & adjust or replace if necessary
	Low side pressure not getting low enough to actuate pressure control	Bad expansion valve

Timer will not actuate harvest	Timer defective Thermo disc is not closed Low pressure cut-in not closing	Replace timer Check thermo disc Replace low pressure cut-in
Unit will not run	Blown fuse Switch in Off position Inoperative main switch Out on high pressure cut-out (Water cooled models)	Replace fuse & check for cause of blown fuse. Turn switch to On position Replace switch Repair cause of high head pressure & reset pressure control
Compressor cycles intermittently	Low voltage Dirty condenser Air circulation blocked Inoperative condenser fan motor Non-condensable gases in system	Check circuit for overloading. Check voltage at the supply to the building. If low, contact the power company. Clean with vacuum cleaner air or stiff brush. (DO NOT USE WIRE BRUSH) Allow sufficient air space all around unit. Check to see if defective If defective, replace. Purge the system
Irregular size cubes and some cloudy	Holes in water distributor tube plugged Shortage of water Unit not level Water distributor tube not properly adjusted	Clean distributor tube. Check water pump & water level in sump trough. Check and level. Adjust
Large cube bridge	Low side control set too low	Raise setting on low side control
Decreased ice capacity	Inefficient compressor Leaky hot gas valve High head pressure	Replace Replace Dirty condenser. Clean. Bad fan motor. Replace. Non-condensable gas in the system. Purge the system. Too hot a location with poor circulation: Relocate the unit, or provide for ventilation by cutting openings Overcharge of refrigerant Correct the charge.

60 CYCLE

Cuber Model	400 Series Water Cooled 60 Cycle	400 Series Air Cooled 60 Cycle		
Compressor Model	RSN20050-1AA	RSN20050-1AA		
Compressor Voltage	115V-60Cy-1Ph	115V-60Cy-1Ph		
Winding Resistance Common to Run	.6 OHMS	.6 OHMS		
Winding Resistance Common to Start	3.8 OHMS	3.8 OHMS		
Start Capacitor Rating	189-210 MFD 220V	189-210 MFD 220V		
Fan Motor Model		MORRILL		
Fan Motor Amps		.82		
Fan Motor Watts		9 Watt		
Fan Motor Volts		115 Volts		
Fan Winding Resistance		28 OHMS		
Solenoid Valve Volts	115V	115V		
Solenoid Valve Winding Resistance	49 OHMS	49 OHMS		
Hartell Water Pump Winding Resistance	9.5 OHMS	9.5 OHMS		
Hartell Water Pump Amperage	1.8 Amps	1.8 Amps		
Refrigerant Charge — R-12	15 Ozs.	28 Ozs.		
Normal machine amperage	13 Amps	14 Amps		
Room Temperature		70	90	110
HEAD Maximum		130	160	200
PRESSURE Minimum		105	125	170
SUCTION Maximum		18	19	21
PRESSURE Minimum		8	9	9

50 CYCLE

Cuber Model	400 Series Water Cooled 50 Cycle	400 Series Air Cooled 50 Cycle
Compressor Model	RSH2-0050-1AG	RSH2-0050-1AG
Compressor Voltage	230V-50Cy-1Ph.	230V-50Cy-1Ph
Winding Resistance Common to Run	1.2 OHMS	1.2 OHMS
Winding Resistance Common to Start	7.6 OHMS	7.6 OHMS
Start Capacitor Rating	41-53 MFD 220V	41-53 MFD 220V
Run Capacitor Rating		
Fan Motor Model	MORRILL	
Fan Motor Amps	.5	
Fan Motor Watts	7.5 Watt	
Fan Motor Volts	230 Volts	
Fan Winding Resistance	20 OHMS	
Solenoid Valve Volts	230 Volt	230 Volt
Solenoid Valve Winding Resistance	22 OHMS	22 OHMS
Hartell Water Pump Winding Resistance	46.5 OHMS	46.5 OHMS
Hartell Water Pump Amperage	.77 Amps	.77 Amps
Refrigerant Charge — R-12	15 Ozs.	28 Ozs.
Normal machine amperage	7.1 Amps	7.1 Amps

Room Temperature	70	90	110
HEAD Maximum PRESSURE	135	175	215
Minimum	110	135	175
SUCTION Maximum PRESSURE	20	21	22
Minimum	8	9	9

CLEANING INSTRUCTIONS

IN PLACE CLEANING

To clean the ice cuber water system without removing the components proceed as follows. NOTE — This is only recommended in locations where impurity build-up is not heavy.

1. Remove ice cuber front panel.
2. Shut off ice cuber.
3. Remove ice from bin.
4. Shut off water supply and remove water from water sump.
5. Pour one bottle of ice machine cleaner into sump and turn supply water on.
6. Place toggle switch to water pump position and circulate cleaner for about 30 minutes.
7. After cleaning shut machine off and remove cleaner. Flush water system thoroughly.
8. Clean ice storage bin with ice machine cleaner also.

DISASSEMBLING WATER SYSTEM FOR CLEANING

To clean parts by removing proceed as follows:

1. Shut machine off.
2. Remove splash curtain, water pump and water distributor.
3. Disassemble distributor as indicated in Fig. 8.
4. Disassemble water pump as follows:
 - A. Turn pump over and remove the water inlet screen. See Fig. 15.
 - B. Hold and depress impeller. Rotate plastic thumb nut counter-clockwise.
 - C. Remove screws and pump housing. Pump is now ready for cleaning.
 - D. Reassemble in reverse order as removed.

Scrub all parts using a nylon scouring pad, brushes, and a cleaning solution such as LIME-A-WAY from Economics Laboratory, Inc. or Boss Brand Milk Stone Cleaner from Northern Laboratories. Rinse all parts with clear water.

It is recommended that the ice be removed from the storage bin before scrubbing the base and evaporator assembly. Rinse with clear water. Check to see that overflow or drain hole in the base is clear and that water drains through freely.

Reassemble unit. To sanitize unit, mix ONE TEASPOON OF CHLORINE BLEACH IN ONE GALLON OF WATER. Pour solution into sump, then turn toggle switch to the left to start water pump.

Keep pouring solution into sump until system has enough to keep pump primed. After one minute, turn off pump and remove solution from water sump. Repeat with clear water before turning switch back to the ice making position. Make visual inspection for leaks and operation before replacing the front panel.

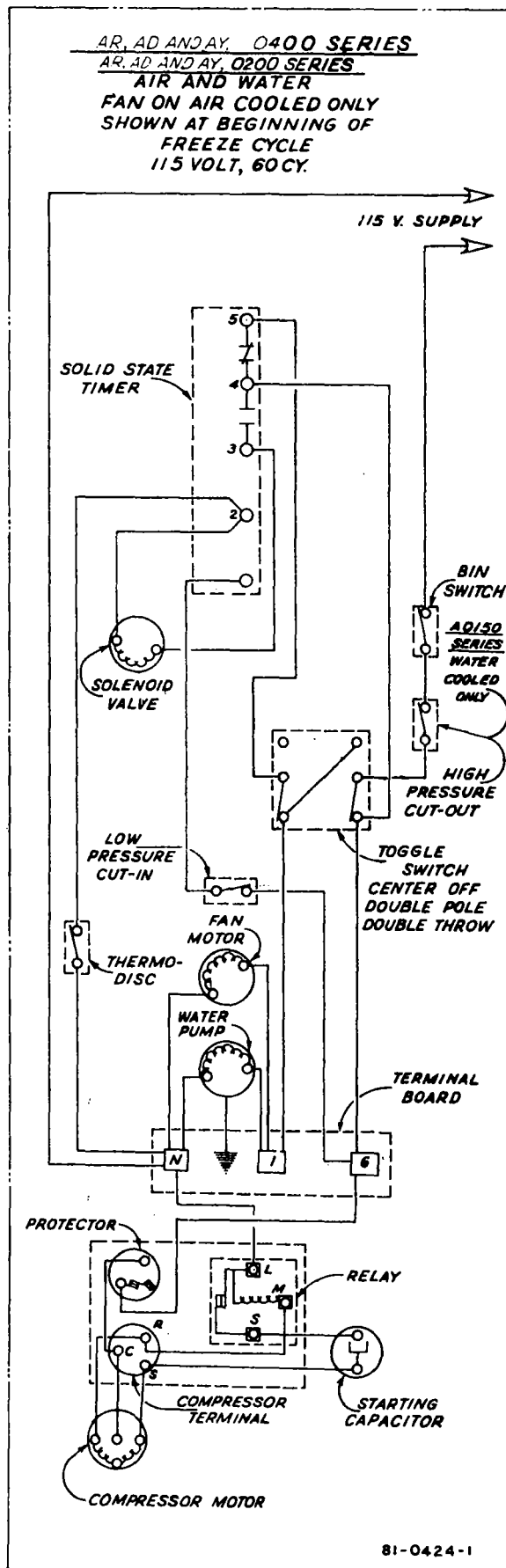

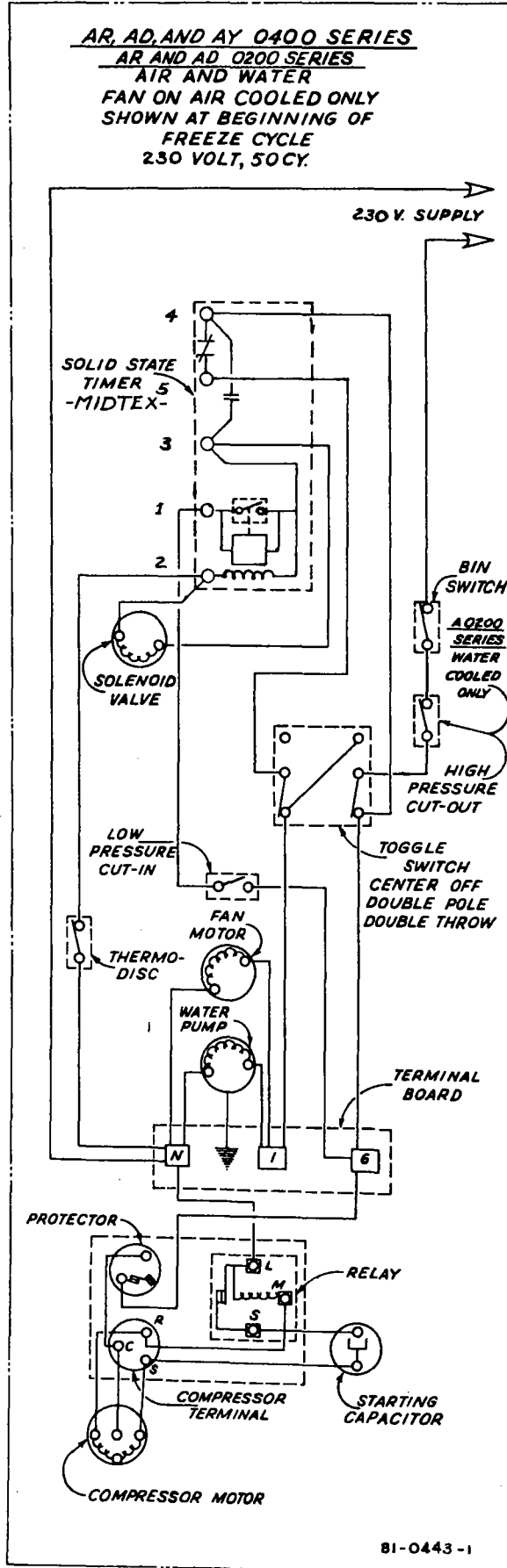

SERVICE AND PARTS PROCEDURES

Ordering Procedure

Replacement parts for Manitowoc ice machine equipment should be ordered directly from your local Manitowoc Ice Machine distributor. Parts are stocked by the distributor in order to provide prompt and efficient service for ice machines sold in their area.

Should you encounter difficulty in locating a Manitowoc distributor in your area, replacement parts may be ordered directly from our factory Parts Department.

When placing your order, be sure to do as follows:

1. Print name and address plainly.
2. If special routing is requested, please show the name of the carrier.
3. Indicate quantity desired, print catalogue part number plainly and print name as shown in the catalogue.
4. Indicate model and serial number of the unit. The complete serial number is needed.
5. If uncertain as to the proper part number, please give a complete description or sketch of the part and the location of the part which is needed.
6. Check to see that all required information is contained in your order to facilitate prompt shipment. All replacement parts are shipped from the factory on a f.o.b. Manitowoc basis. It is company policy to bill for all field replacement parts, according to terms as specified by our Credit Department.

All parts orders will be honored by the factory and will be billed according to our parts list schedules.

Parts which are covered by our warranty policy are to be returned to the factory for credit, transportation charges prepaid. Upon receipt of these parts here at the factory, they will be inspected; and if they are found to be defective, in material and workmanship, under normal use and service, credit will be issued.

Transportation companies are responsible for damage in transit as all shipments are tendered to them in good condition; and our responsibility ceases upon receipt of a signed bill of lading from the carrier. If the shipment arrives in a damaged condition or is short, the delivery carrier should be notified immediately.

Return of Defective Parts

All defective parts returned to the factory, transportation prepaid, must be tagged with a return material tag properly filled in. It is especially important that the cabinet serial number be secured and recorded on the tag, securing as much information as possible about the nature of the defect to prevent any delays in issuing credit. All parts should be returned as they are removed from the cabinet and not mutilated or tampered with. The return material tags are provided on a no-charge basis by the factory upon receipt of your request.

Our warranty and protection plan does not apply to cabinets that are not registered; therefore, it is necessary that, upon completion of the installation of the cabinet, the registration card be signed on the date of installation and mailed promptly to the factory Service Department in order for the cabinet to be registered.

Return of Hermetically-sealed Units

Extreme care should be used in servicing the hermetically-sealed mechanism. It is important that the trouble be correctly determined before the unit is changed. Be sure it is not the control, relay, or overload causing the trouble. The defect must be listed on the return material tag.

Return of Complete Machines

No complete machines may be shipped back to the factory for repairs without first securing prior permission from the factory. If an unauthorized shipment is received at the factory, it will be refused by our warehouse and immediately returned to the sender. Upon receipt of your request to return a cabinet, if we feel that your request is legitimate, you will be sent an authorized return label authorizing you to return this cabinet to the factory freight prepaid.

Service and Labor Charges

In accordance with our warranty and protection plan, which is included in each cabinet, this protection plan provided is available only through distributors and dealers who will be solely responsible for service and labor charges.

SERIAL NUMBER NOMENCLATURE

STARTED JAN., 1979

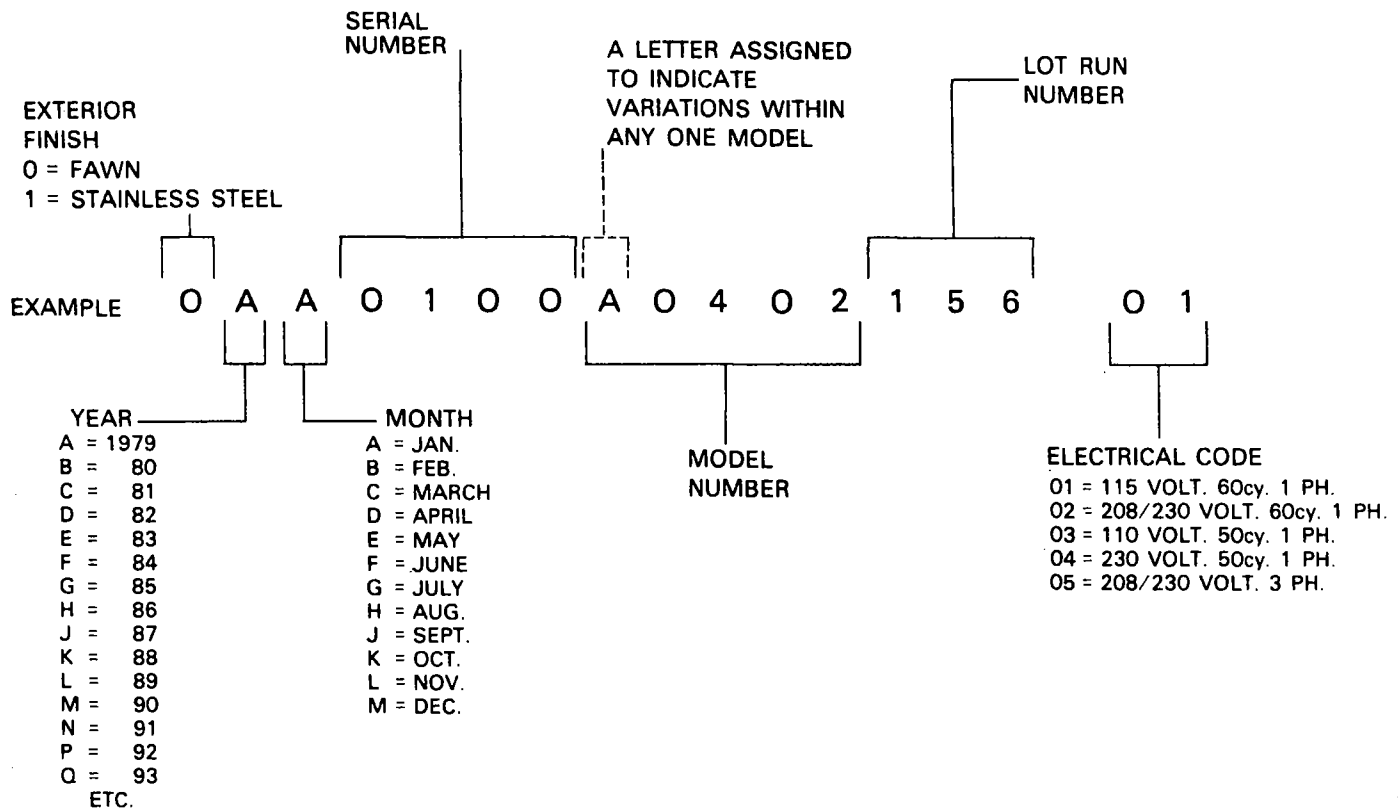

Ice Machine and Bin Warranty

From the date of original installation, we do hereby warrant each new Ice Machine and Bin to be free from defects in material and workmanship, under normal use and service, for a period of one year, and four additional years on the hermetic motor compressor in the Ice Machine.

Our obligation under this warranty is limited solely to correcting or replacing without charge at the factory in Manitowoc, Wisconsin any part or parts of this equipment which shall have been returned, transportation prepaid, and which our examination discloses to our satisfaction to be defective.

This warranty does not apply to any equipment that has been damaged by flood, fire, or suffered abuse, misuse, neglect or accident, or to any Ice Machine which has been altered so as to affect performance or reliability, except where such alteration has been accomplished with our prior written consent.

We further limit this warranty in that we shall not be held liable under this contract for any special, indirect, or consequential damages whatsoever resulting from any defect in material and workmanship which interferes with the normal use and service of such Ice Machine and Bin.

This warranty is a complete and exclusive statement of all terms of the agreement between the Manitowoc Equipment Works and the owner of the equipment, and all representations of the parties. This agreement shall not be varied, supplemented, qualified or interpreted by any prior course of dealing between the parties or by any usage of the trade.

Sales are made on the express understanding that there are no express or implied warranties other than the express warranty herein contained and that there are no implied warranties that the goods shall be merchantable or fit for a particular purpose other than the expressed one year and five year warranty set forth above.

To validate this warranty, the registration card must be signed on the date of installation and mailed promptly to the Manitowoc Equipment Works, Manitowoc, Wisconsin.

DEALER _____

INSTALLATION DATE _____

MANITOWOC EQUIPMENT WORKS
Div. of THE MANITOWOC COMPANY
500 South 16th Street
Manitowoc, Wisconsin 54220