

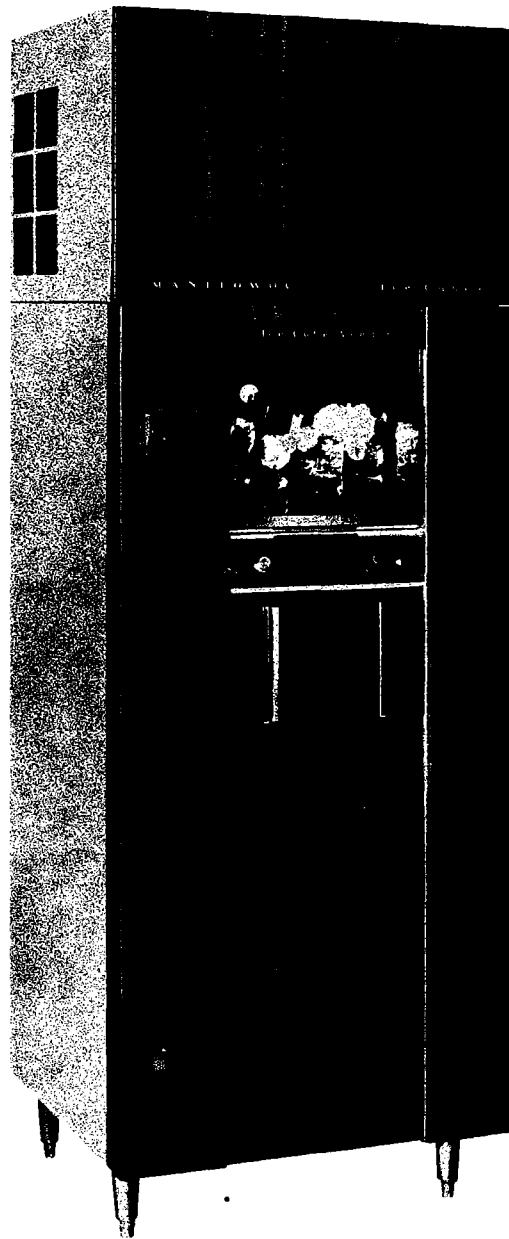

Manitowoc

AC-0370 ICE VENDER

SERVICE MANUAL



Manitowoc equipment works

Division of The Manitowoc Company, Inc.

MANITOWOC
WISCONSIN

80-0056-3
October, 1979

TABLE OF CONTENTS

Forward	Page 1
Uncrating and Inspection	Page 2
Location and Installation	Page 2
Ice Cuber Rear Mounting Plate	Page 2
Mounting Front of Ice Cuber to Vender	Page 2
Vender Bucket Pan and Grill Assembly	Page 2
Coin Changer and Acceptor	Page 2
Price Changing Instructions	Pages 2-3
Electrical Connections	Page 3
Serial and Electrical Plate	Page 3
General Requirements	Page 3
Connecting Power Supply to Ice Vender	Page 3
Fig. 1 — Junction Box Hook Up	Page 4
Connecting Vender Bin Water Drain Lines	Page 4
Check List for Starting Ice Cuber	Page 4
Final Check List for Vender	Page 4
Ice Making Section Specifications and Dimensions	Page 5
Fig. 2A — Dimensions with "400" Series Cuber	Page 6
Fig. 2B — Recommended Vender Ice-Bucket	Page 7
How the AC-0370 Vender Works	Pages 7-8
The AC-0370 Electrical Controls and Sequence of Operation	Page 8
Wiring Diagram	Page 9
Circuit Analysis	Pages 10-11
Check Point Procedure	Page 12
Removing Lock-Out Switch	Page 13
Removing Motor and Gear Drive Assembly	Page 13
Removing Electric Motor from Gear Reducer	Page 13
Gear Reducer	Page 13
Removing Auger Assembly	Page 13
Upper and Lower Bearing Assembly	Page 14
Removing Coin-Acceptor and Coin-Changer	Page 14
Fig. 3 — Front View of Dispenser & Cuber	Page 15
Fig. 4 — Internal Door Components	Page 16
Fig. 5 — Internal Door Components	Page 17
Fig. 6 — Internal View of Dispenser Bin	Page 18
Fig. 7 — Rear View of Dispenser with Cuber	Page 19
Figs. 8, 9 and 10 — Auger Drive Assembly	Pages 20-21
Fig. 11 — Lower Bearing Assembly	Page 22
Removing Decal Light Fixture	Page 23
Removing Bucket Pan and Grill Assembly	Page 23
Removing Weight Control Switch Assembly	Page 23
Removing Timer Board or Power Relay	Page 23
Bucket Pan and Weight Control Switch Mtg. Inst.	Page 23
Weight Control Switch Adjustment Instructions	Pages 23-24
Cleaning Instructions	Page 24
Fig. 12 — Display Light Assembly	Page 25
Fig. 13 — Bucket Pan and Weight Control Switch Setting	Page 26
Fig. 14 — Sliding Door Return Spring Field Replacement Procedure	Page 27
Fig. 15 — Sliding Door Micro Switch Adjustment Procedure	Page 28
Fig. 16 — Coin Rejector Mechanism	Page 29
Fig. 17 — Coin Changer and Parts Removed for Cleaning Procedure	Page 30
Coinco Branches and Service Centers	Page 31
Service and Parts Procedures	Pages 31-32
Serial Number Nomenclature	Page 32
Warranty	Page 33

FORWARD

Manitowoc Equipment Works, Division of the Manitowoc Company, Inc., Manitowoc, Wisconsin presents this Service Manual to assist the Serviceman with information concerning Construction, Installation and Maintenance of the Manitowoc AC-0370 Ice Vender.

The problems of the user and the serviceman have been given special emphasis in the development of the latest Manitowoc ice machines and venders.

If you encounter a problem which is not answered by the manual, please feel free to write or call the Service Department of the Manitowoc Equipment Works, describing the problem you have encountered. The Service Department will be happy to give you particularized advice and assistance. Whenever calling or writing, please state the complete Model and Serial Number of the ice making and ice vending equipment.

MANITOWOC EQUIPMENT WORKS
Div. of THE MANITOWOC CO., INC.
2110 South 26th Street
Manitowoc, Wisconsin 54220
(414) 682-0161

MODELS

This manual covers the following Model(s) AC-0370 Multi-coin operated ice vender.

Please refer to the Ice Cuber Service Manual for additional information regarding installation, maintenance and servicing the following ice cuber models, which are installed with the Ice Cube Vender AD-402A, AD-403W.

WARRANTY

Parts and Material	One year — parts only
Compressor	Five years — parts only

Defective parts must be returned transportation prepaid.

(See "Ice Machine and Bin Warranty" page 33 and registration card shipped with the unit for warranty conditions.)

UNCRATING AND INSPECTION

The AC-0370 ice cube vender is shipped to you in a heavy cardboard carton to help prevent damage in transit. Upon delivery of the ice vender, inspect the carton thoroughly before signing the freight bill and uncrating the vender. If the carton should show signs of rough handling, have delivering carrier note freight bill that possible damage may exist.

To uncrate the vender, remove banding along the lower bottom edge of the carton. Remove the carton by sliding up and off of vender. Remove the four (4) corner posts and inner carton. Inspect vender for possible concealed damage. If damage is evident notify carrier at once for their inspection. Be sure to hold carton for their inspection. Upon completion of their inspection, file a freight claim with the delivering carrier.

Remove sheet metal screws (2) from door alignment bracket (Fig. 1). Remove door keys (taped to bucket housing pan). Unlock door and swing open approx. 90°. Unpack leg box (taped to vender base) and screw 606 legs into vender bottom mounting holes.

LOCATION AND INSTALLATION

After legs are securely in place, locate vender in desired location. Be sure to allow enough height for the ice cuber section to be installed on top of vender.

Once the vender is located, allow a minimum of 5 inches on all sides for air circulation. If the 400 Series ice cuber is to be used with the vender there must be a minimum of 5 inches from the back of the vender to the wall. Level bin side to side and front to back. Remove all shipping tape and packaging from bin, including carton for cuber door spacer.

Unlock and swing open front door (Fig. 3). Remove the 14 thumb screws fastening auger access panel to front of bin liner (Fig. 6). Remove wooden shipping wedge placed between top of auger and upper bearing assy. The wedge is to hold the auger in place during shipping (See Fig. 6).

Uncrate your Manitowoc ice cuber and refer to the Service Manual found in the instruction envelope packed inside the ice cuber. Carefully set the ice cuber on top of the vender bin. Be sure cuber is set squarely on the vender bin to insure accurate ice delivery into the vender bin (See Fig 3).

ICE CUBER REAR MOUNTING PLATE

To secure ice cuber to vender, look for a rear mounting plate and 3 #8 x ½ mounting screws packaged separately and taped to leg box.

After ice cuber has been properly mounted on top of vender, secure mounting plate to rear of ice cuber and vender (see Fig. 7, Item 9) with #8 x ½ sheet metal screws.

MOUNTING FRONT OF ICE CUBER TO VENDER

Once the ice cuber has been properly mounted on vender, use the two holes in the vender top rail as shown in Fig. 6 to drill two holes in bottom of ice cuber base. Using two sheet metal screws, front of ice cuber can be secured to vender.

VENDER BUCKET PAN AND GRILL ASSY.

For proper operation of the weight control mechanism, the bucket pan and grill assembly must have free movement. Remove all shipping tape, check for clearance and free movement (Fig. 13).

COIN CHANGER AND ACCEPTOR

Remove all shipping tape attached to coin changer. Remove acceptor and place in area free of foreign material. Check changer for vertical position. If correction is required, loosen three mounting screws and correct position of changer; tighten screws.

PRICE CHANGING INSTRUCTIONS

1. Disconnect power from vending unit by turning key lock switch off (bottom right hand side). (NOTE: The coin changer and acceptor work equally well with American and Canadian coins.)

2. Remove the coin acceptor. There are four price select slide switches (2 black and 2 white) located on upper portion of printed circuit board. These switches are "ON" when in the UP position (Fig. A).
3. Set the vend price by sliding sufficient price select switches (total max. 75¢) into UP position to total the desired price. Example: 10¢ and 40¢ in UP position = 50¢.

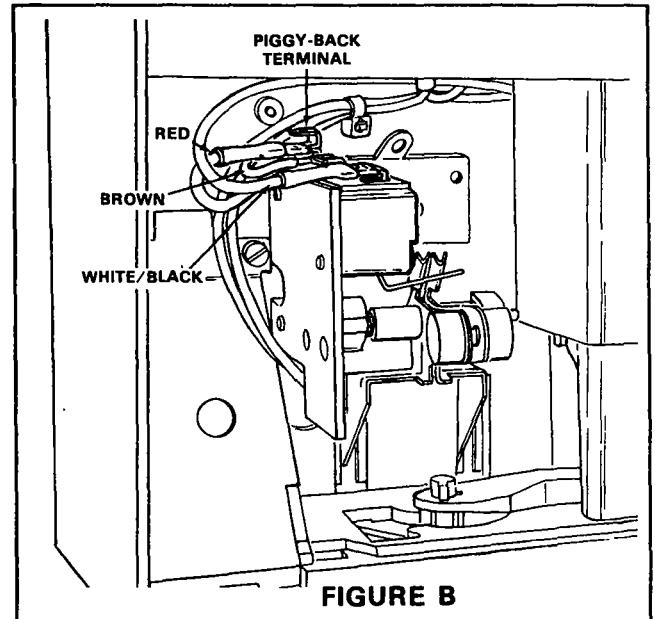
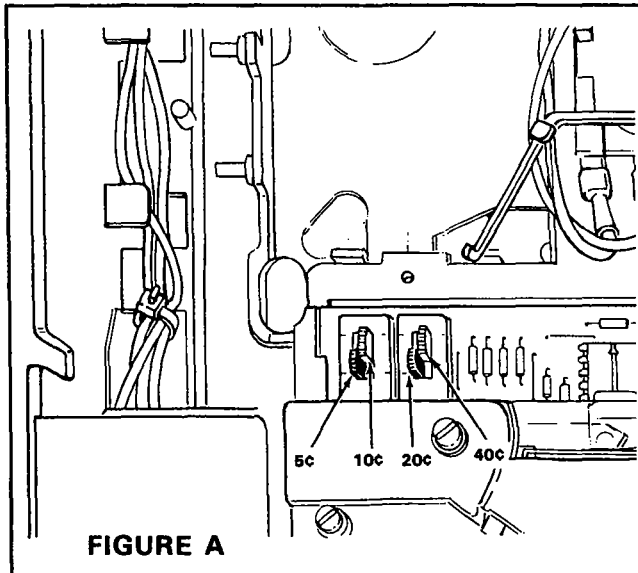

4. If you have vend price 25¢ and above, and you want to continue to accept quarters when the change tubes are empty (exact change light indication), remove the back coverplate and disconnect the white wire from the normally closed terminal of the tube empty switch. Reconnect this wire to the piggy-back terminal on the common (red wire) of the same switch (Fig. B). Replace the back coverplate.
5. For vend prices up to 75¢ in exact change. If you desire for coin changer to respond to exact coin insertion only, reverse above wiring procedure. Replace the back cover plate.
6. Snap coin acceptor back into position.

ELECTRICAL CONNECTIONS

115 VAC — 60 Hertz — Single Phase (Requires separate outlet) 15 amps Max.

Junction Box Hook-up Fig. 1. See ice cuber service manual for ice cuber electrical connections.

SERIAL AND ELECTRICAL PLATE

The combined serial number and electrical plate is located on outside of the vender on upper right hand side front corner. Be sure to send complete model and serial number of your vender when calling or writing for parts or service.

GENERAL REQUIREMENTS

All electrical and water supply and drain connections must conform to local codes.

CONNECTING POWER SUPPLY TO ICE VENDER (FIG. 1)

Your vender should be connected to a separately fused circuit. Fuse size must not exceed maximum fuse size shown on the electrical plate. 115 VAC — 60 Hertz Single Phase, minimum ampacity 5.8 Amps.

All electrical wiring connected to your vender must be rated equal to the minimum circuit ampacity shown on the electrical plate.

Remove rear access panel (Fig. 7) and place the wires through the electrical supply hole (Fig. 7). Remove

cover from electrical wiring box (Fig. 8) and connect the supply leads to wires in electrical wiring box vender. The two 115V supply leads go to lead wires marked # L₁ and # L₂.

**FIG. 1 JUNCTION
BOX HOOK-UP**

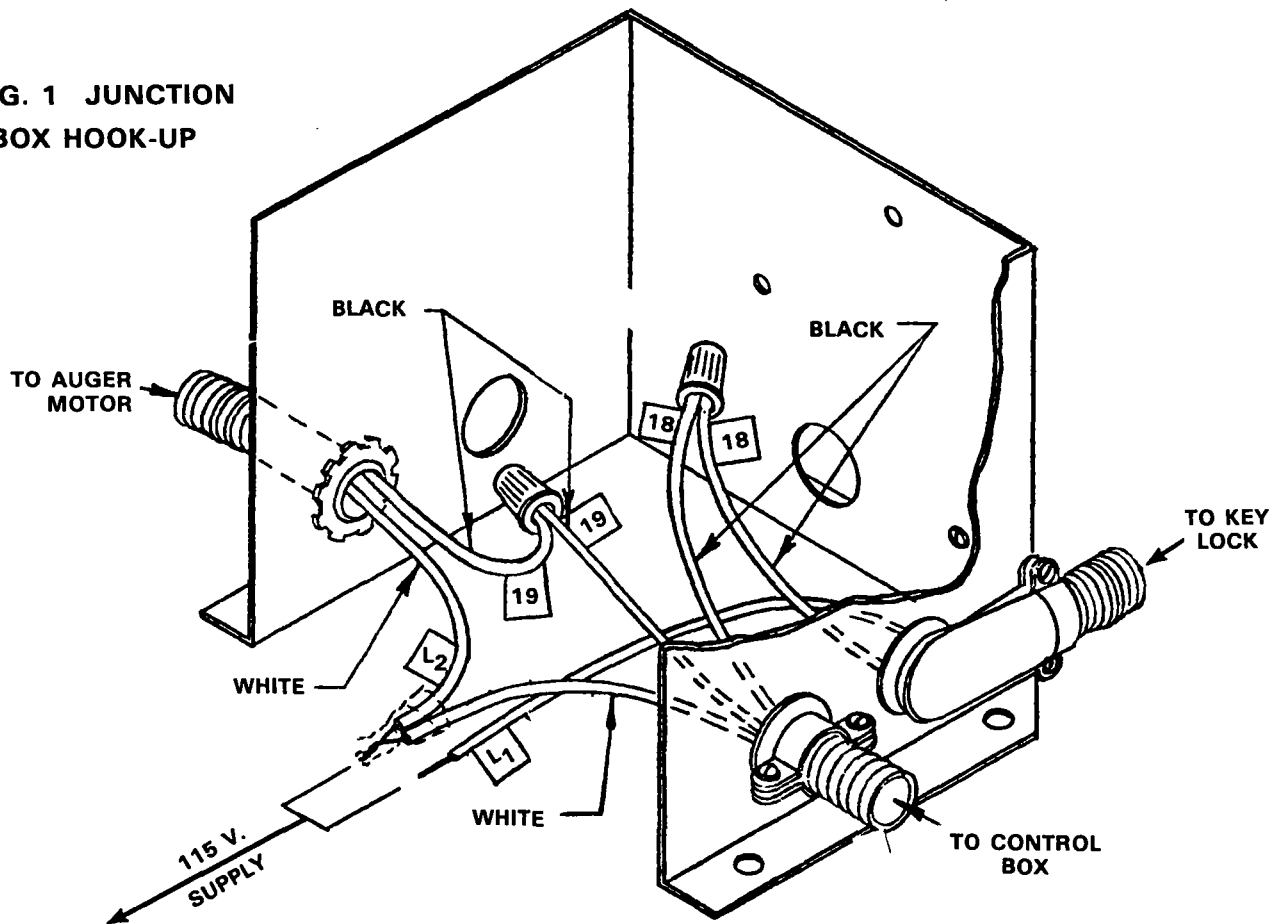

CONNECTING VENDER WATER DRAIN LINES

Connect drain lines to the two ½" female pipe fittings in rear of the vender (See Fig. 7 & 8). It is essential that drain connections be made so waste water cannot back up into the bin. Check all local plumbing codes. All vender drain connections are labeled (See Fig. 7). Drain lines must be at least ½" inside diameter and have 1½" drop per 5 feet of run. We recommend covering all incoming water drain lines with a plumbing insulation material to prevent condensation.

CONNECTING WATER SUPPLY TO ICE CUBER

Refer to cuber service manual found inside instruction envelope with ice cuber.

CHECK LIST FOR STARTING ICE CUBER

Refer to service Manual found inside instruction envelope inside ice cuber.

FINAL CHECK LIST FOR VENDER

1. Is vender bin level? (Important)
2. Refer to ice cuber service manual and find check list for checking ice cuber.
3. Has wooden shipping wedge been removed from top of auger and upper bearing assy.? (See Fig. 6)
4. Has owner been instructed on how to operate and clean ice vender and ice cuber?
5. Have warranty registration cards for both vender and Ice Cuber been filled out properly and mailed to our Service Dept.? This is for the owner's protection in order that equipment can be registered to validate the warranty.
6. Has electrical box cover been replaced?

Ice Making Section Specifications

"400" SERIES ICE PRODUCTION (Pounds per 24 Hours)	Incoming Water Temp. (F)		Room Temperature (F)		
			70°	80°	90°
	Air Cooled Unit	59° 70° 90°	330 290 250	300 260 220	270 230 190
	Water Cooled Unit	59° 70° 90°	380 340 300	370 330 290	360 320 280

Ice Making Section Dimensions

MODELS	"400" SERIES	
	AD0402A	AD0403W
Height	20-5/16"	20-5/16"
*Width	30"	30"
Depth	23-9/16"	23-9/16"
Approx. Ship. Wt. (lbs.)	232	233
Compressor Size	1/2 H.P.	1/2 H.P.

NOTES: All Ice Cubers described are equipped for "Dice" Cube production. "A" Models are air cooled — "W" Models water cooled.
ELECTRICAL CHARACTERISTICS: 115 VAC — 60 Hertz — Single Phase. Minimum Ampacity 18 Amps.

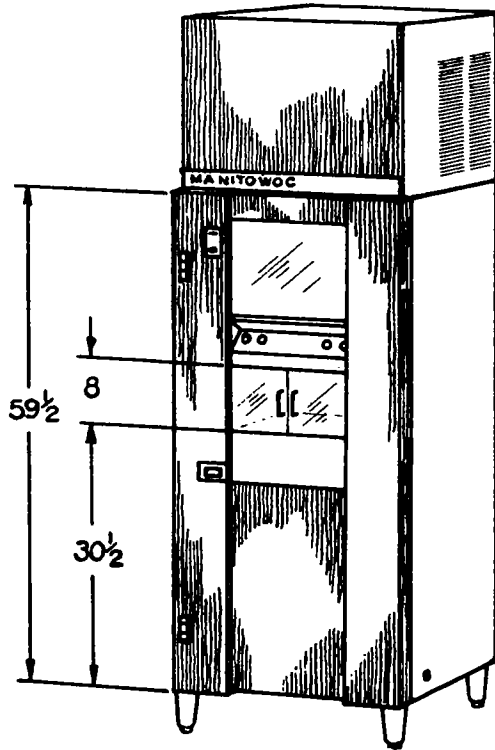

DIMENSIONS — AC-0370 VENDER —
with "400" SERIES CUBER — 606 ADJUSTABLE LEGS

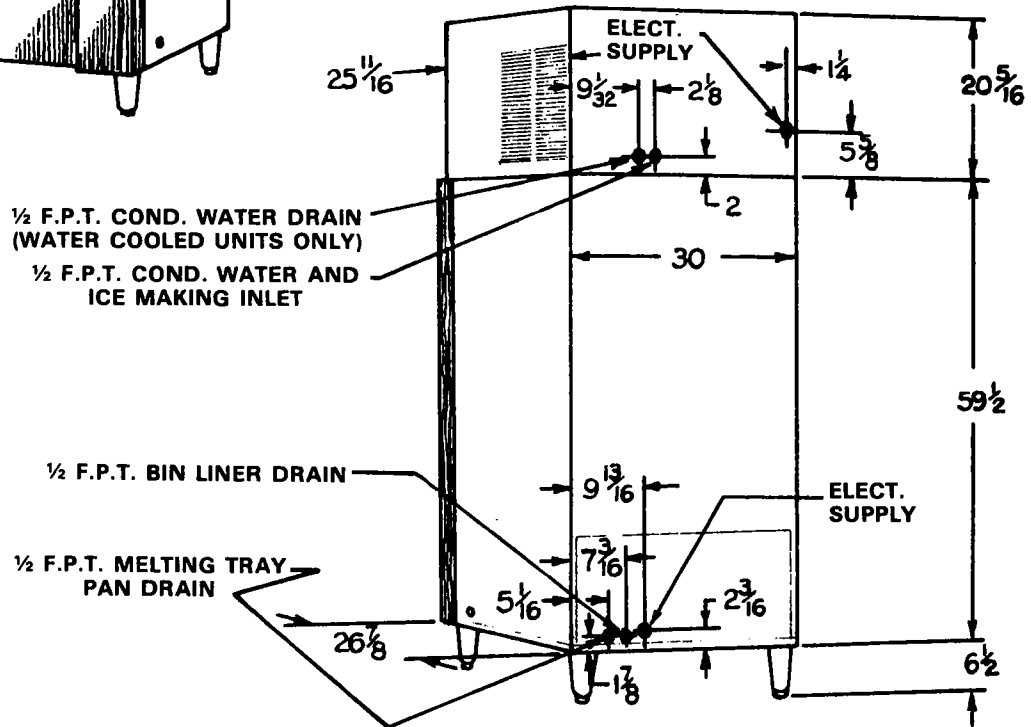

FIG. 2A

Recommended Vender Ice-Bucket

Bucket Capacity: 3 Quart
 Bucket Shape: See Below
 Bucket Material: High Density Styrene
 Bucket Approval: F.D.A.
 Bucket Miscellaneous: Color white, Dishwasher — Safe
 Bucket Supplier: #1 Wescon Corp., 46 Power Street,
 (Preferred) Milford, NH 03055, Tel. # 603-673-8444

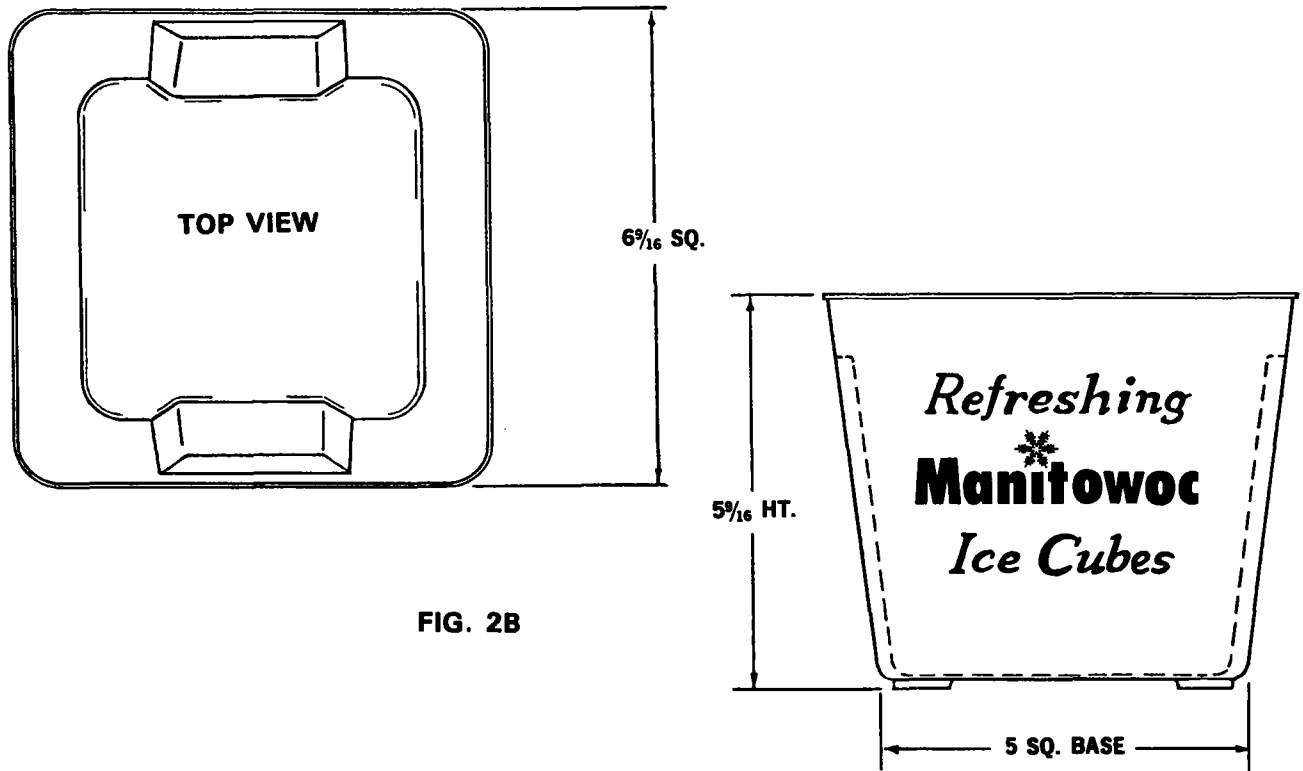

FIG. 2B

HOW THE AC-0370 VENDER WORKS

To dispense ice, place the proper size container inside the bucket housing. This will break the photoelectric eye beam. Allow the spring loaded door to close. Fig. 3, Item 15. If the photoelectric eye beam is not broken or the door is not closed, the vender will reject any coins.

Insert the coins in the coin slot. Fig. 3, Item 8. The coins will activate the dispensing mechanism and turn the green light on. Fig. 3, Item 10. Ice will be dispensed into the ice bucket until the weight of the ice reaches the set point on the scale switch. The scale switch will shut the vender and the green light off. The full container of ice can now be removed.

Opening the bucket door before the vend is complete will immediately shut the vender off. New coins will have to be inserted to restart the vend.

To protect the customer from losing their money when the vender is near empty, there is an adjustable 2 minute timer monitoring each vend. This timer is usually set at 1 minute. This is sufficient time to dispense 4 lbs. of ice, (standard 3 qt. bucket will hold approximately 3 lbs. of ice), providing the vender has sufficient ice. Should the vend take longer than 1 minute to vend a full bucket, the 2 minute timer will start a one hour timer and the empty light will come on. Fig. 3, Item 13. Note: The existing vend will run until the bucket is full or the door is opened.

While the one hour timer is timing out, the vender will not accept any coins. The one hour period allows the cuber time to produce new ice for the vender. When the one hour timer has completed it's timing sequence, the empty light will go out and the vender will accept coins.

The AC-0370 will accept quarters, dimes and nickels and give change back in nickels only. (See price changing instruction, Page 32.) If the changer is out of nickels the exact change light will come on. Fig. 3, Item 12.

Key Lock-out Switch. Fig. 6, Item 6. This key operated lock-out switch will permit the owner to turn the vender completely off. Any coin(s) inserted in the vender will be rejected. This key switch does not turn the cuber off.

THE AC-0370 ELECTRICAL CONTROLS AND SEQUENCE OF OPERATION

Sequence I, (Page 11) Bucket in Place

Placing an ice bucket into the bucket housing will break the photoelectric eye light beam. This will close the set of contacts between terminals 3 & 4 or 6 & 4 on the photoelectric eye, depending on the make of the photo control, completing the L2 side of the circuit to the coin mechanism coils. Closing the bucket door will close the door switch completing the L1 side of the circuit through the weight control switch and the normally closed set of contacts of CR2 and CR1 to the coin mechanism coils and switch. The vender is now ready to receive coin(s).

Sequence II, (Page 11) Coin(s) Received and Dispensing

The coin mechanism will accept the coin(s) tripping the coin switch. This will energize the CR1 relay and contacts, the TD1 two minute timer relay, the green light, advance the counter and start the auger motor, thus dispensing ice. When the bucket is full the weight control switch will open, de-energizing the CR1 & TD1 relays, the green light and auger motor, stopping the vend.

Sequence III, 2 Minute timer initiates the 60 minute timer.

If the ice bucket does not fill before the end of the setting of the TD1 two minute timer, the TD1 relay will close it's contacts, energizing the 60 minute TD2 timer and the empty light. The existing vend will continue until the scale switch opens or the customer opens the bucket door.

Sequence IV, 60 Minute Replenishing Cycle

The coin mechanism will refuse any coin(s) inserted while the TD2 is timing out. When the TD2 timer has completed it's timing sequence the TD2 relay will energize, opening the TD2 contacts which in turn de-energize the CR2 relay. The CR2 relay contacts will open, de-energizing the TD2 timer and the empty light. The vender will now accept coin(s) for a new vend.

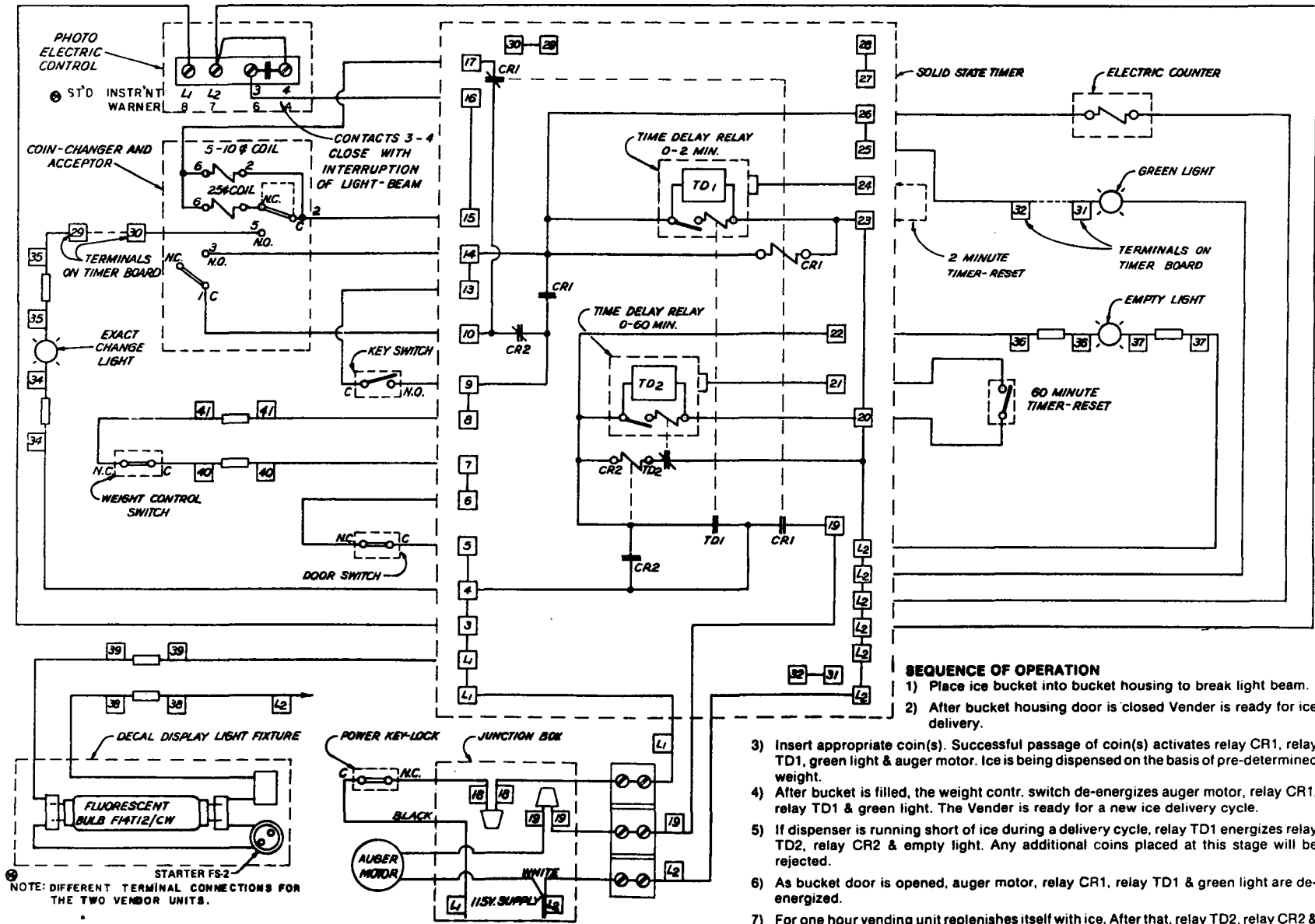

SEQUENCE OF OPERATION

- 1) Place ice bucket into bucket housing to break light beam.
- 2) After bucket housing door is closed Vender is ready for ice delivery.
- 3) Insert appropriate coin(s). Successful passage of coin(s) activates relay CR1, relay TD1, green light & auger motor. Ice is being dispensed on the basis of pre-determined weight.
- 4) After bucket is filled, the weight contr. switch de-energizes auger motor, relay CR1, relay TD1 & green light. The Vender is ready for a new ice delivery cycle.
- 5) If dispenser is running short of ice during a delivery cycle, relay TD1 energizes relay TD2, relay CR2 & empty light. Any additional coins placed at this stage will be rejected.
- 6) As bucket door is opened, auger motor, relay CR1, relay TD1 & green light are de-energized.
- 7) For one hour vending unit replenishes itself with ice. After that, relay TD2, relay CR2 & empty light cut out. Vender ready for fresh ice delivery.

CIRCUIT ANALYSIS

SEQUENCE I

Bucket in place (light-beam broken), door closed, vender ready to receive coin(s).

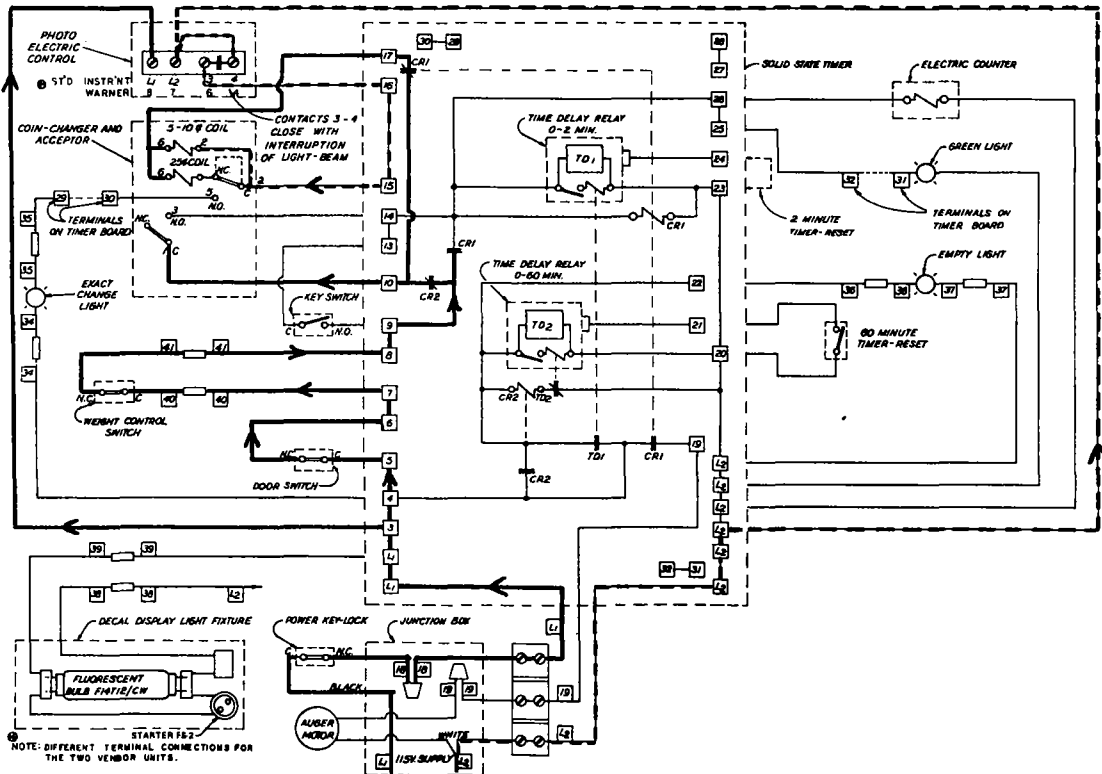

SEQUENCE II

Coin received, relay CR1, TD1, electric counter, green light and auger motor are energized; after bucket is filled, weight control switch de-energizes relays, light and motor.

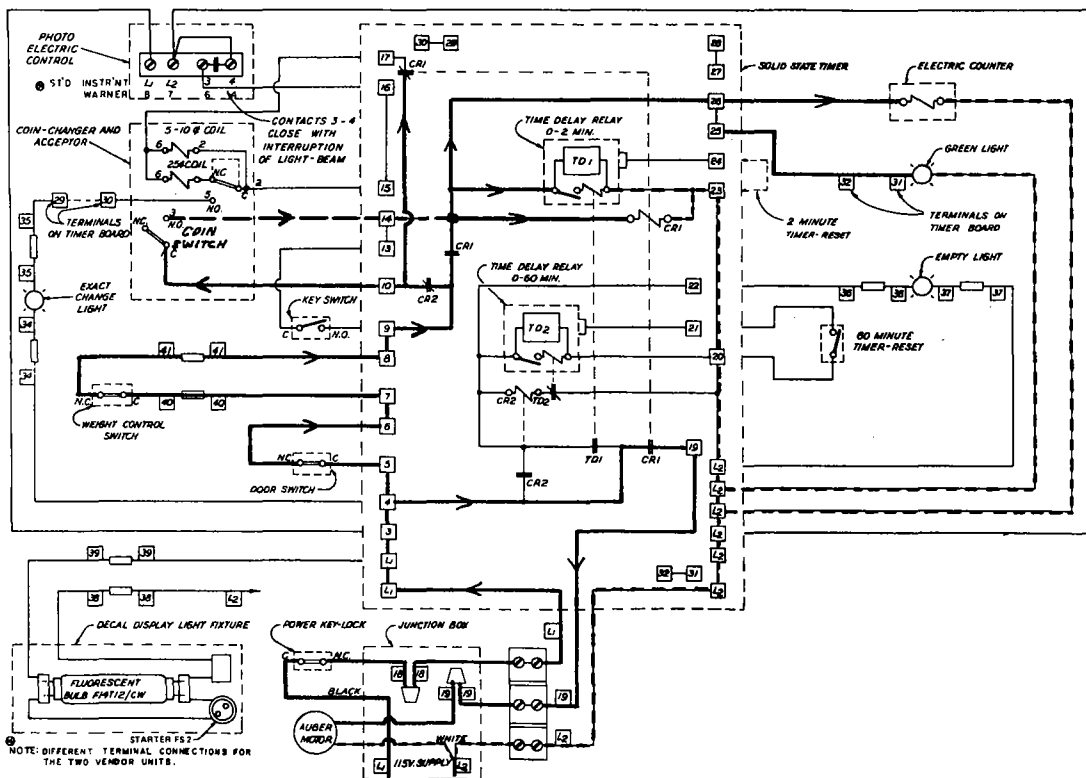

CHECK POINT PROCEDURE IN CASE THE VENDER DOES NOT OPERATE PROPERLY

Possible problem: Coin is rejected, despite bucket doors closed, bucket in place and empty light indication.

- a. Check for power across terminals 9, 10, 17 and L₂. If power indication, door switch, weight control switch and NC contact of relay CR2 are working. If not, check all mentioned switches.
- b. Check for power across terminals L₁ and 15. If power indication, photo-electric control is functioning properly (light beam broken). If no power indication, either light beam is not broken or photo control is out of order.
- c. If there is power at terminals 15 and 17 and **both coils of coin-mechanism are not pulled in**, check leads, plug and coin-mechanism. If defective, contact us or nearest Coinco Service Station. (See service manual.)

Possible problem: Auger does not start, after coin acceptance.

- a. Check whether a count is made on counter after inserting another coin. If counter has digitized forward check relay CR1 visually for burn-out or slack positioning. Replace if defective.
- b. Check for power across terminals 19 and L₂ (after coin insertion). If there is power, inspect auger motor; if not, check relay CR1. Replace if defective.

Possible problem: Auger keeps running, after filling bucket with ice.

- a. Check power across terminals 8 and L₂. If there is power, examine weight control switch (setting) and bucket pan/grill assy. for free movement. Replace switch if necessary. Clear obstructions, if any.
- b. If there is no power across terminals 8 and L₂ check relay CR1; replace if necessary.

Possible problem: No indication of empty light at slow or no ice delivery.

- a. Check power across terminals 22 and L₂. If there is power, replace empty light bulb.
- b. If there is no power, time delay relay TD1 or relay CR2 could be defective. Replace timer circuit board.

Possible problem: Vender remains on empty indication, after ice has replenished inside vending bin.

- a. Time delay relay TD2 or control relay CR2 defective. Replace timer circuit board.

Possible problem: Ice delivery slow.

- a. Near empty vender. Check cuber for proper operation.
- b. Ice clusters, check ice bridging on cuber.
- c. Low ambient, freezing temperatures causing ice to freeze together.

Possible problem: Electric motor operates, but auger does not turn.

- a. Defective gear reducer. Check and replace.
- b. Set screw loose or coupling retainer key missing. Replace key and tighten set screw.
- c. Auger not properly seated on lower bearing drive shaft. Check and adjust auger on bearing drive shaft.

REMOVING LOCK-OUT SWITCH

Should the lock-out switch need replacement proceed as follows:

1. Disconnect power to the vender.
2. Open vender Door.
3. Remove switch box cover (See Fig. 6).
4. Remove switch wire leads and mounting screws and remove switch (See Fig. 12).
5. To replace key lock remove lock retainer hex nut located in junction box and remove lock from outside of vender.

REMOVING MOTOR AND GEAR DRIVE ASSEMBLY

To remove the complete auger drive motor and gear reducer from rear of the vender for maintenance or replacement proceed as follows:

1. Unlock and swing open front door.
2. Remove rear access panel (Fig. 8) by removing the four mounting screws (Fig. 8).
3. Shut off power to vender and disconnect power lead wires inside gear drive motor junction box.
4. Remove bin support brackets from rear gear drive mounting bracket (Fig. 10) and the two sheet metal screws holding bin support bracket to bottom of bin liner.
5. Loosen the four machine screws (Fig. 9 and 10) holding the front and rear mounting brackets to gear reducer. This will allow the gear reducer and motor assy. to drop down partially disengaging the coupling on the reducer drive shaft.
6. Loosen the set screws on both upper and lower halves of the coupling. Slide upper coupling up on lower bearing shaft so it will be out of the way.
7. Slide lower half of coupling up and off of the reducer drive shaft.
8. Remove the four machine screws mounting front bracket to the gear reducer (Fig. 9).
9. Remove the four machine screws (Fig. 10) mounting rear bracket to the dispenser base.
10. Complete gear reducer and motor with rear mounting bracket can be removed from the vender through the rear access opening.
11. To reassemble reverse the above procedures in Item 10, 9, 8, 7, 6 and 5.

REMOVING ELECTRIC MOTOR FROM GEAR REDUCER

1. Remove mounting bolts holding electrical drive motor to gear reducer (See Fig. 9).
2. Using a slotted screw driver start to pry motor loose from gear reducer. Once separation has started screw driver will no longer have to be used since the assembly comes apart quite easily.

GEAR REDUCER

The gear reducer has a red vent and fill plug located on top of the reducer (See Fig. 9). This plug is vented to prevent pressure from building up inside of gear reducer and blowing out the oil seals. Due to slow RPM of the gear reducer there should be no need to change the oil in the gear reducer.

Should the oil have to be replaced, remove the red vent and fill plug, and refill with **9 oz. of #600W Mobile oil.**

Grease fitting on top of gear reducer is used in production to grease upper gear reducer bearing. Due to the slow RPM of gear reducer there should be no need to grease upper bearing on reducer.

REMOVING AUGER ASSEMBLY

To remove the auger assembly for cleaning or maintenance proceed as follows:

1. Unlock front door and swing open (See Fig. 3).
2. Remove the 14 thumb screws fastening auger access door to bin liner (See Fig. 6) and remove auger access door.
3. Lift auger (Fig. 6) up to disengage bottom of auger from lower bearing drive shaft. Move bottom of auger to the side and pull down to disengage it from upper bearing assembly. Auger assembly can now be removed from inside of the bin.
4. To reinstall the auger assembly, reverse the above procedure. Make sure bottom end of auger is properly seated on lower bearing drive shaft at bottom of the bin.
5. Note that the slot on top of auger shaft is longer than slot on bottom of auger shaft.

UPPER BEARING ASSEMBLY

Upper bearing assembly is located near the top of vender, above the auger (See Fig. 6). Remove the auger assembly, then remove the three mounting bolts fastening bearing assembly to top liner support rail (See Fig. 6).

LOWER BEARING ASSEMBLY

Lower bearing assembly consists of a lower bearing housing, bearing, lower bearing shaft and pin, lower seal housing and lower seal (See Fig. 11). To disassemble the lower bearing assembly proceed as follows:

1. Auger out ice from vender.
2. Remove 14 thumb screws from auger access door and remove rest of ice from bottom of storage bin.
3. Remove gear drive and motor assembly as explained on Page 13 under heading REMOVING MOTOR AND GEAR DRIVE ASSEMBLY.
4. Remove the three $\frac{3}{8}$ -16 x 2 $\frac{1}{4}$ lg. hex lock nut located at outside of bin liner in gear drive and motor compartment (See Fig. 11).
5. Remove three bearing mounting bolts from inside of bin (See Fig. 11).
6. Remove drive pin from lower bearing drive shaft (See Fig. 11). These pins are in extremely tight so they will not work themselves loose. A hammer and drift pin will have to be used to remove it.
7. Lower bearing seal housing can now be removed from bottom of bin liner (See Fig. 11).
8. Lower bearing housing, shaft and lower seal can now be removed (See Fig. 11).
9. To replace, reverse the above procedure. Make sure to use RTV sealer to seal lower bearing seal housing and lower bearing housing to bottom of bin liner (See Fig. 11).

REMOVING COIN-ACCEPTOR AND COIN-CHANGER

1. Remove power from vending unit by turning key lock switch off (bottom right hand side).
2. Unplug coin-changer electrical receptacle (See Fig. 4).
3. Remove coin-acceptor by lifting RH and LH latches and place in area free of dirt and foreign material.
4. Loosen mounting screws in three key holes, lift coin changer and out of position (Fig. 4).
5. To replace reverse above procedure (See Fig. 4). Also lift coin rejecter bracket when coin changer is placed in position (See Fig. 16).
6. Load the nickel coin tubes, making sure all nickels lie flat.
7. Test with a variety of coins to insure proper setting of sales price and proper loading of the nickel tubes.
NOTE: If the coin changer fails to function properly, call one of the following service centers nearest to your unit installation. (See Page 31.)

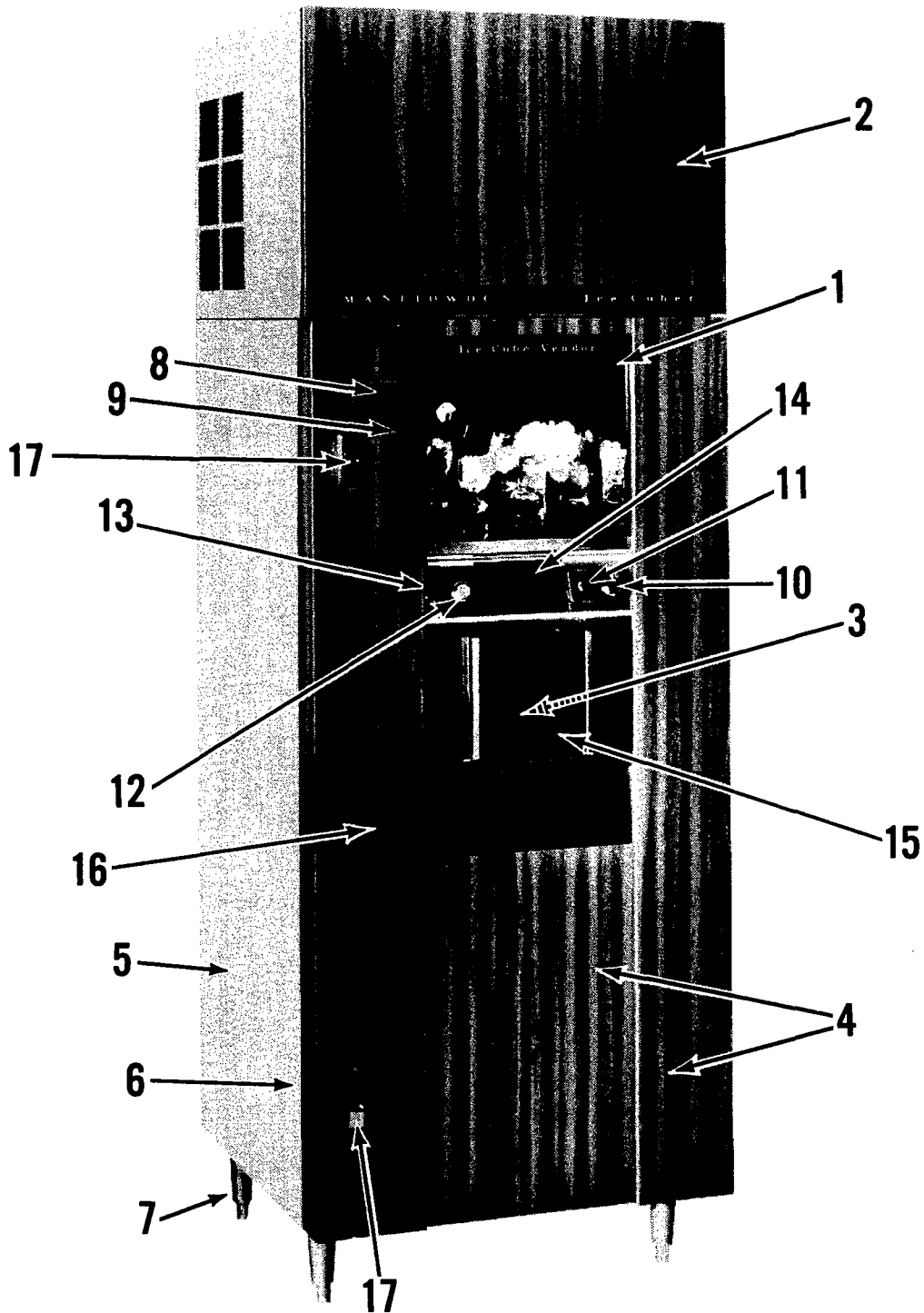

FIG. 3 FRONT VIEW OF DISPENSER WITH CUBER HEAD

- | | |
|--------------------------------|---|
| 1. Decal display. | 10. Indicator light for ice delivery. |
| 2. 400 series ice cuber. | 11. Key switch for ice delivery (without coin). |
| 3. Bucket housing compartment. | 12. Indicator light for exact change. |
| 4. Vender door. | 13. Indicator light for empty vender bin. |
| 5. Vending unit. | 14. Operating instructions. |
| 6. Door alignment bracket. | 15. Bucket compartment door. |
| 7. 606 legs. | 16. Coin return slot. |
| 8. Coin acceptor slot. | 17. Door locks. |
| 9. Coin rejector pin. | |

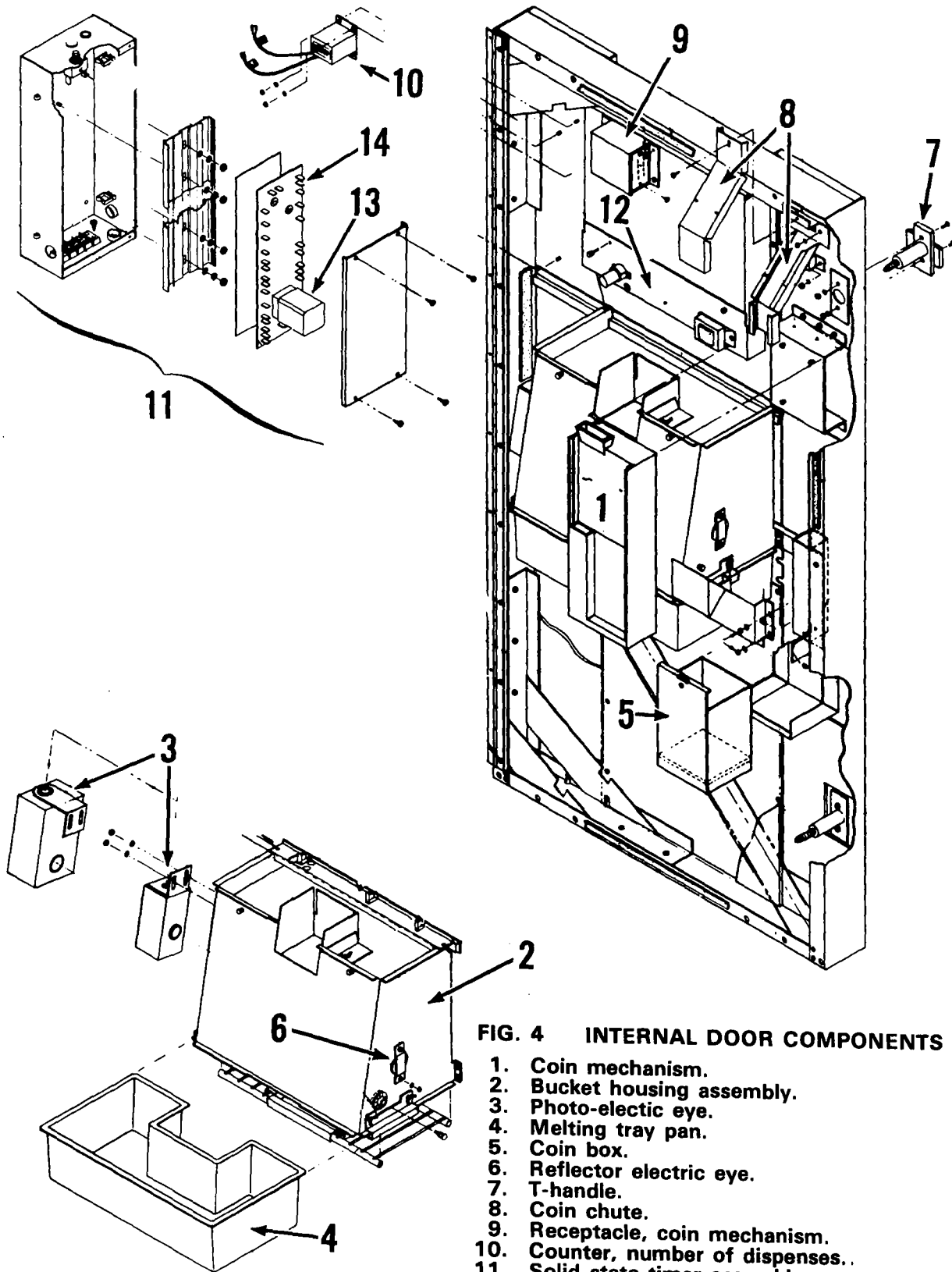

FIG. 4 INTERNAL DOOR COMPONENTS

1. Coin mechanism.
2. Bucket housing assembly.
3. Photo-electric eye.
4. Melting tray pan.
5. Coin box.
6. Reflector electric eye.
7. T-handle.
8. Coin chute.
9. Receptacle, coin mechanism.
10. Counter, number of dispenses.
11. Solid state timer assembly.
12. Display light assembly, transformer and starter.
13. CR1 relay.
14. Timer board.

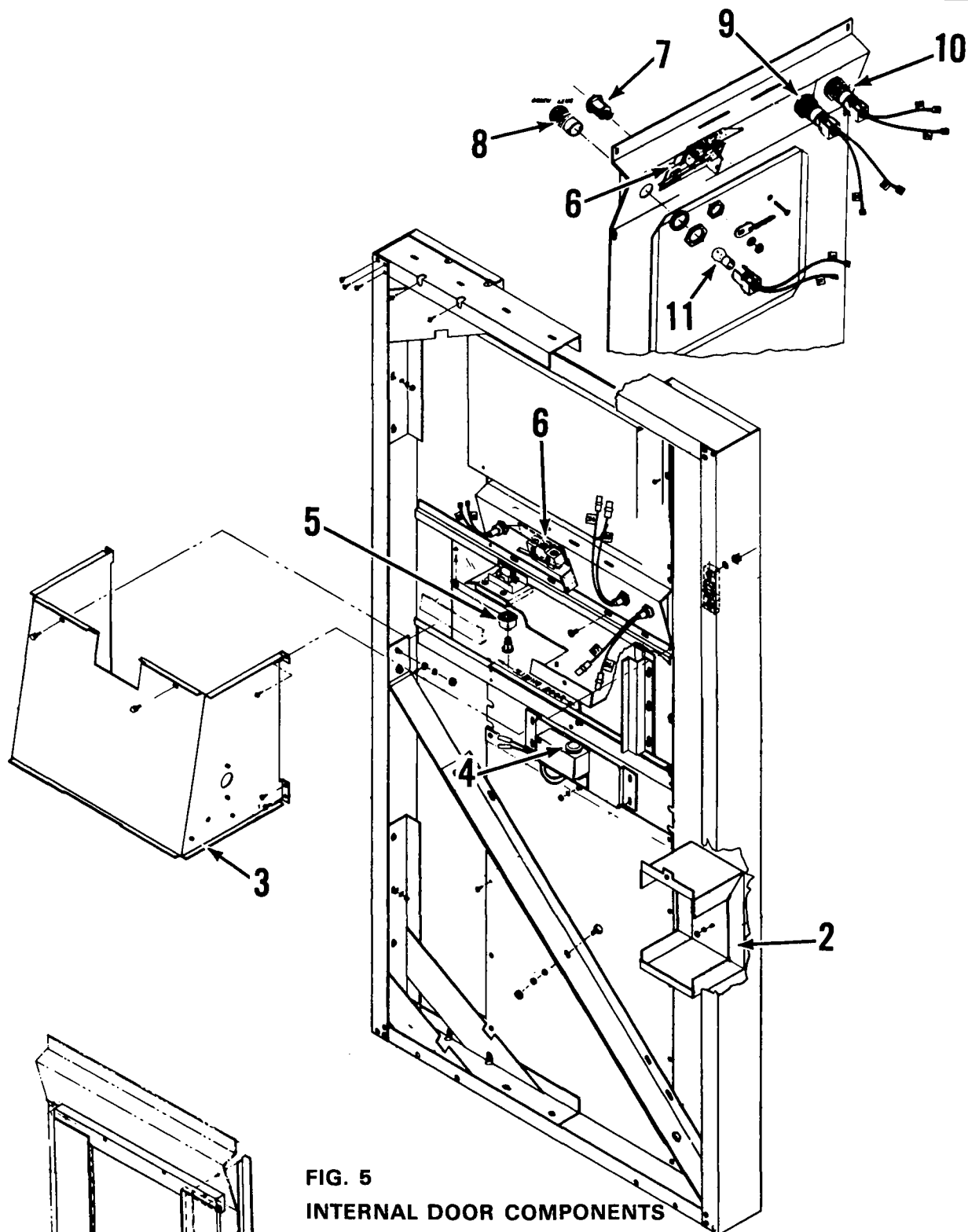

FIG. 5
INTERNAL DOOR COMPONENTS

1. Bucket door assembly.
2. Coin box holder.
3. Bucket housing.
4. Weight control.
5. Door spring.
6. Micro switch, ice keylock.
7. Ice keylock.
8. Green indicator, running.
9. White indicator, correct change.
10. Red indicator, empty.
11. Lamp for indicators.

1 Bucket Door Trim & Panel
Assembly (In Front of Door)

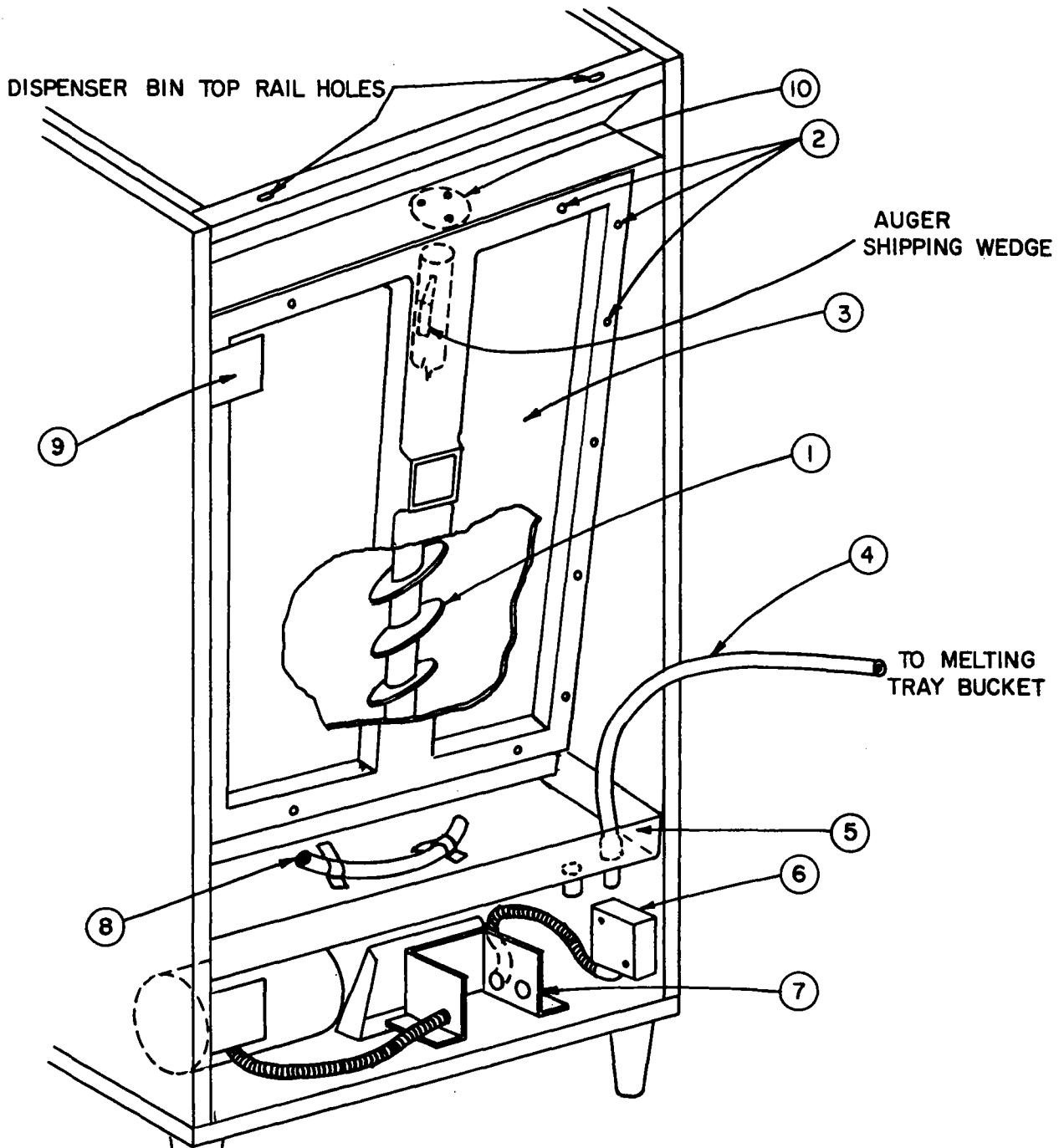

FIG. 6 INTERNAL VIEW OF DISPENSING BIN

1. Auger 4" dia.
2. Thumb screw holding auger access door to bin liner.
3. Auger access door.
4. Tygon tube to lower bin base drain.
5. Lower base drain pan.
6. Key lock (out) switch assembly.
7. Junction box.
8. Drain-tube for cuber.
9. Door lock bracket.
10. Upper auger bearing.

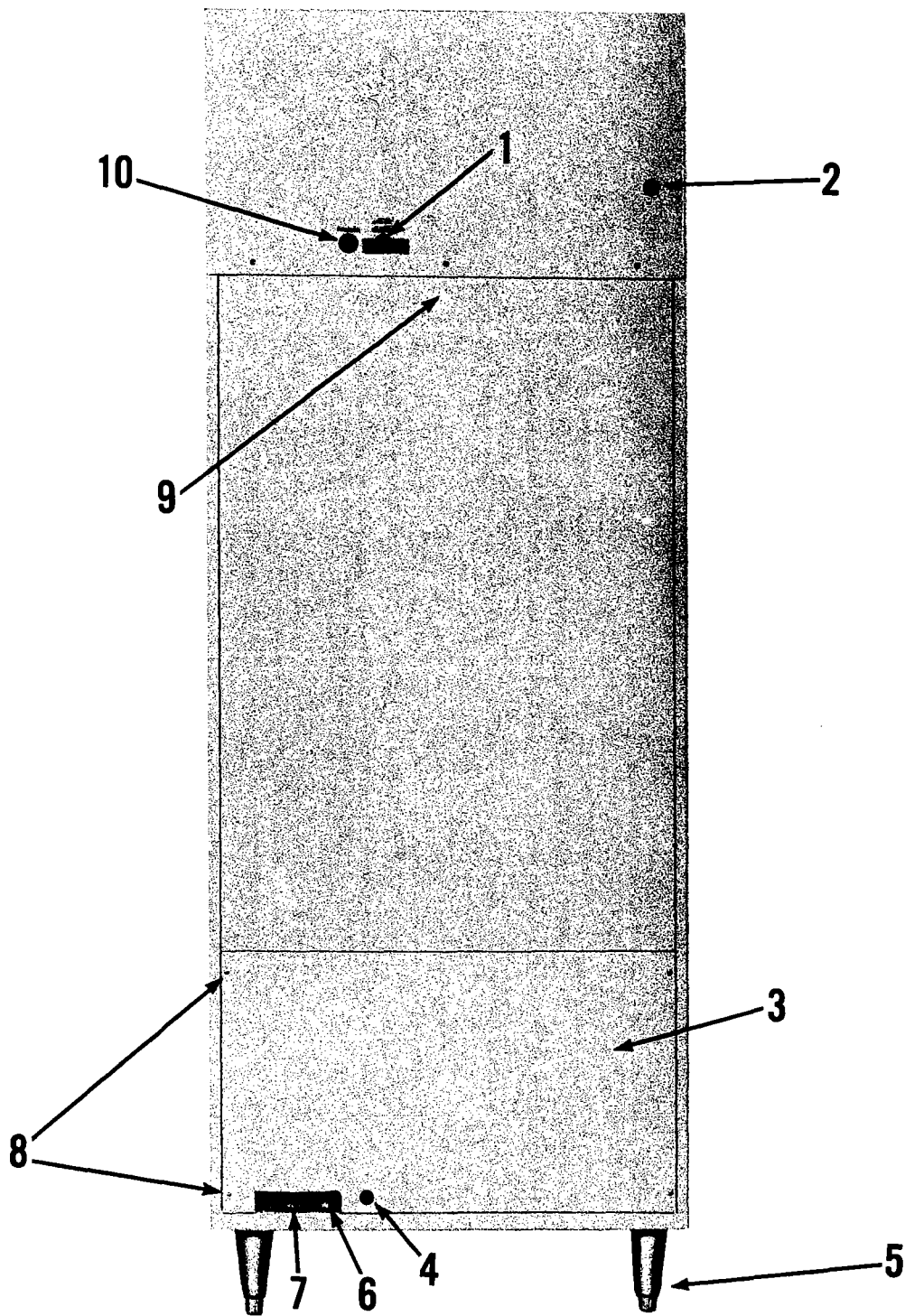

FIG. 7 REAR VIEW OF DISPENSER WITH CUBER

1. Fresh water inlet for ice cuber.
2. Electrical inlet for ice cuber.
3. Rear access panel.
4. Dispenser electrical inlet opening.
5. 606 bin leg.
6. Bin drain fitting.
7. Melting tray and bin liner pan drain fitting.
8. Rear access panel mounting screws.
9. Location of rear mounting clip fastening ice cuber to bin.
10. Ice cuber water condenser drain (Water cooled only).

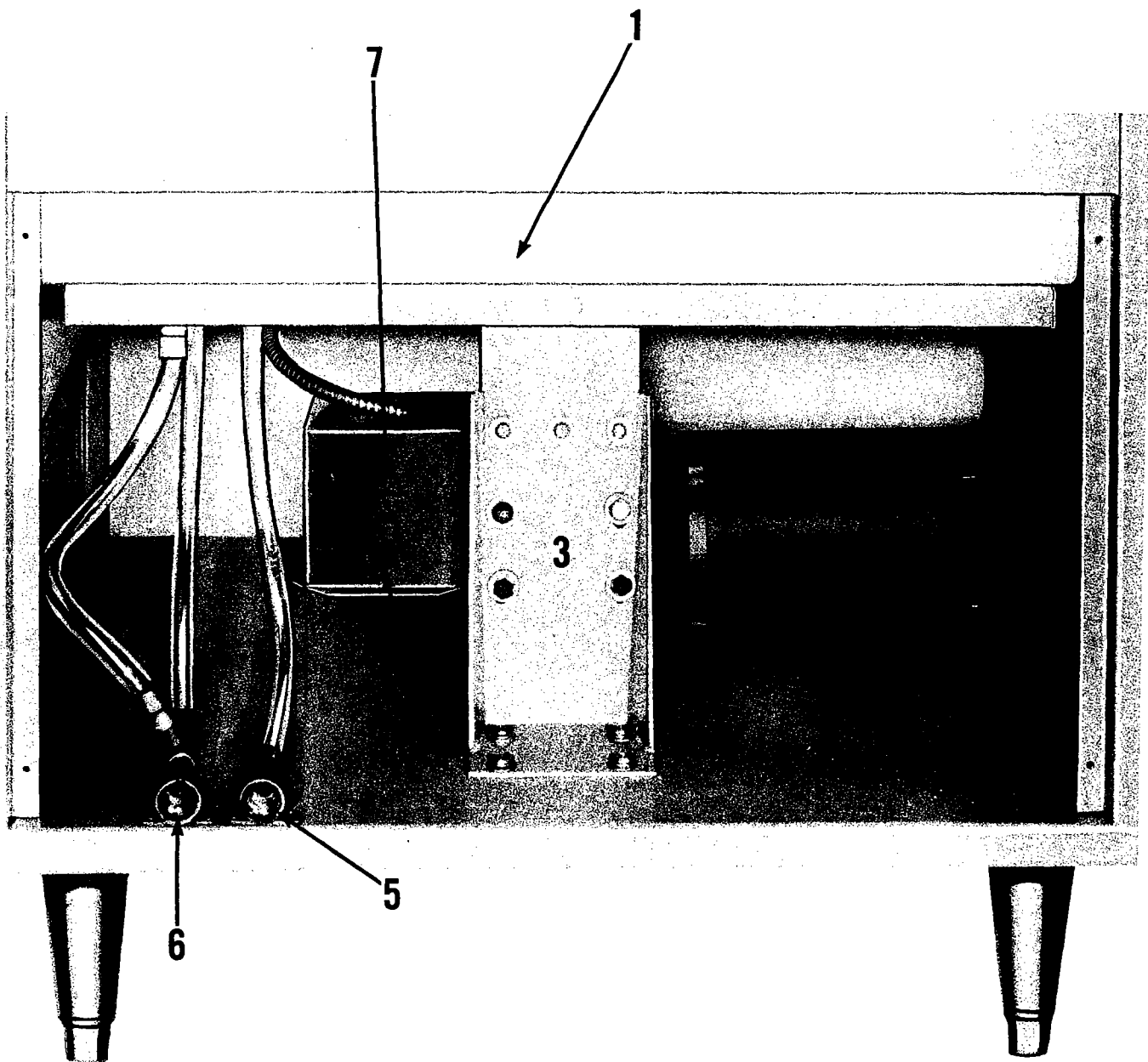

FIG. 8 AUGER DRIVE ASSEMBLY

1. Bin liner drain pan.
2. Gear drive motor.
3. Gear reducer rear mounting bracket assembly w/rear bin liner support bracket attached.
4. Electrical opening in electric box.
5. Bin drain fitting and tubing. Shown without insulated covering.
6. Melting tray and bin liner drain pan drain fitting and tubing.
7. Electrical junction box.

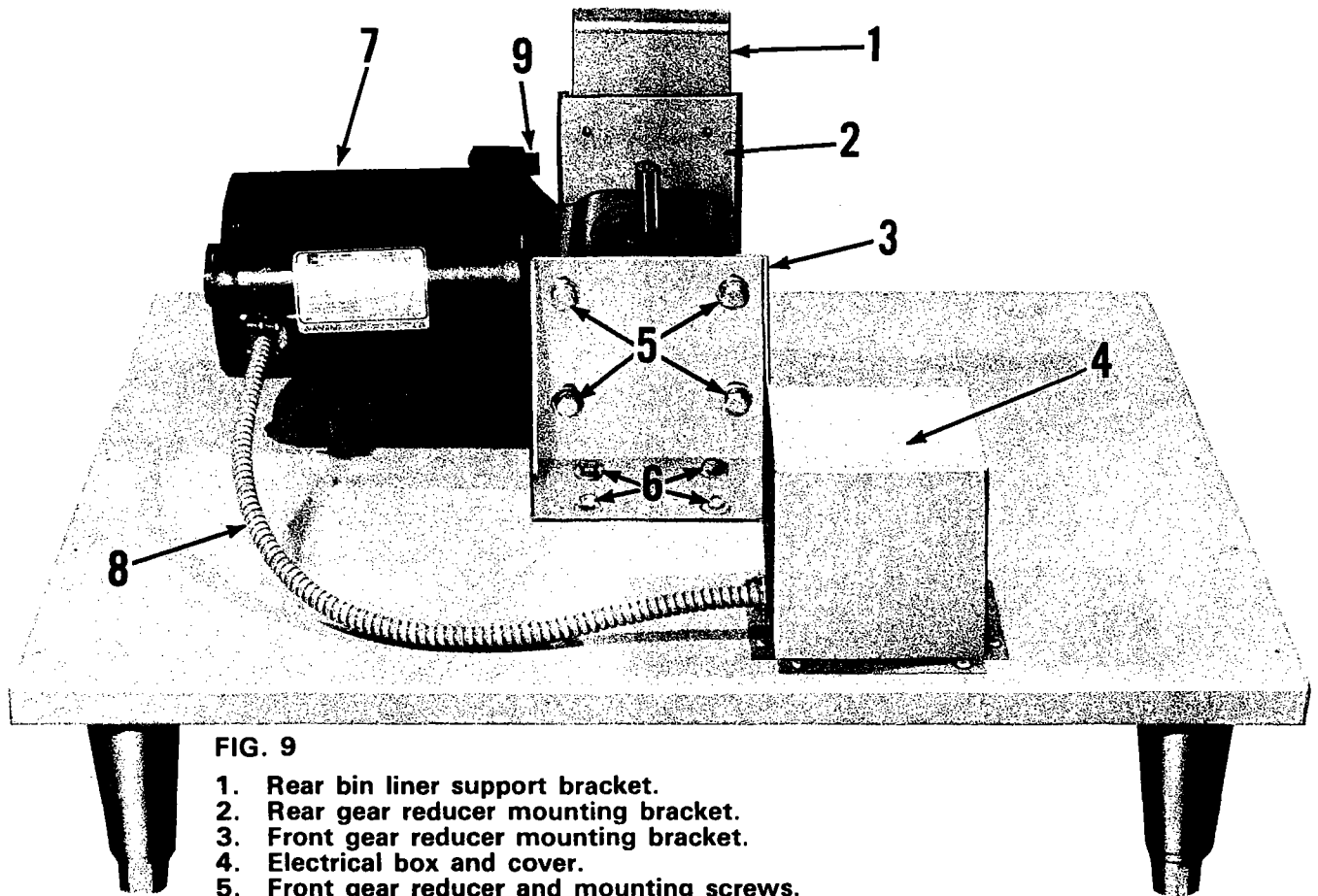

FIG. 9

1. Rear bin liner support bracket.
2. Rear gear reducer mounting bracket.
3. Front gear reducer mounting bracket.
4. Electrical box and cover.
5. Front gear reducer and mounting screws.
6. Front gear reducer bracket mounting screws (mounting bracket to dispenser base).
7. Gear reducer drive motor.
8. Electrical lead from electrical box to gear drive motor.
9. Motor to gear reducer mounting screws.

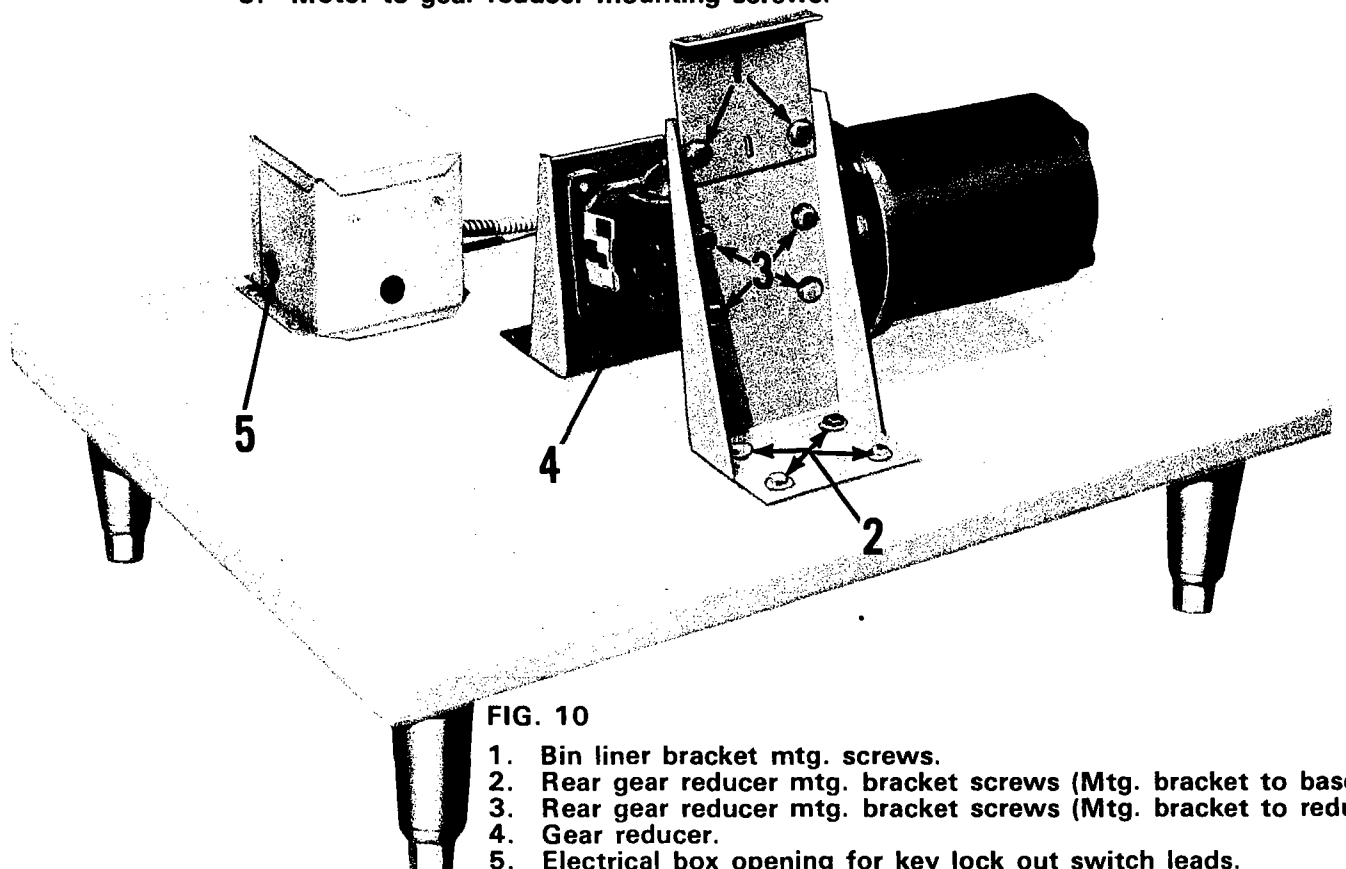

FIG. 10

1. Bin liner bracket mtg. screws.
2. Rear gear reducer mtg. bracket screws (Mtg. bracket to base).
3. Rear gear reducer mtg. bracket screws (Mtg. bracket to reducer).
4. Gear reducer.
5. Electrical box opening for key lock out switch leads.

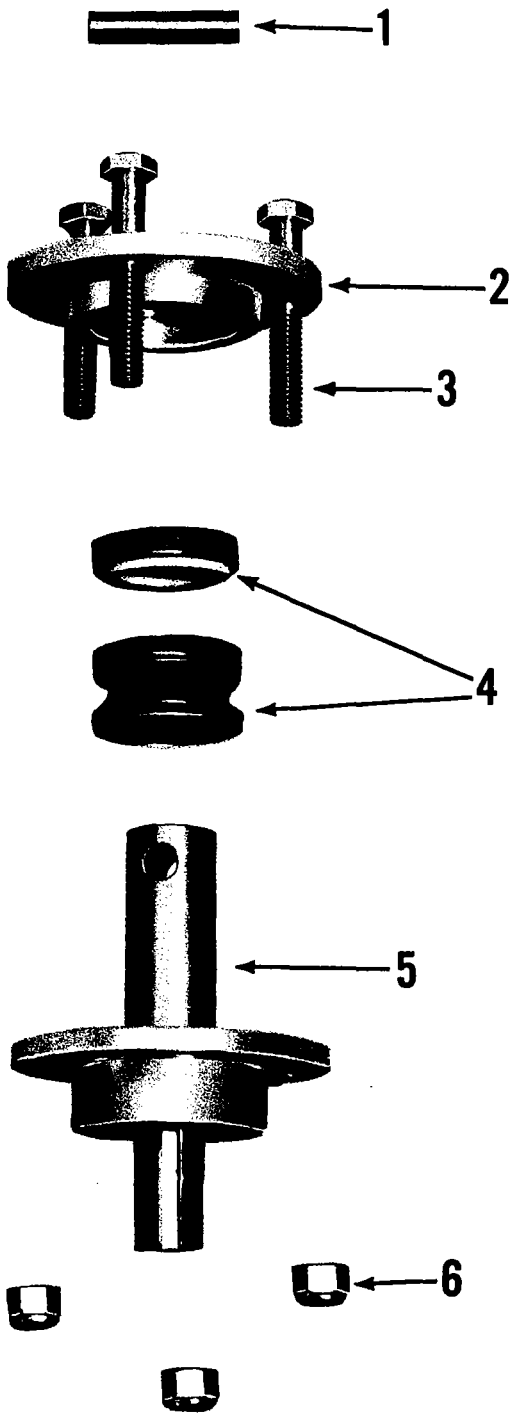
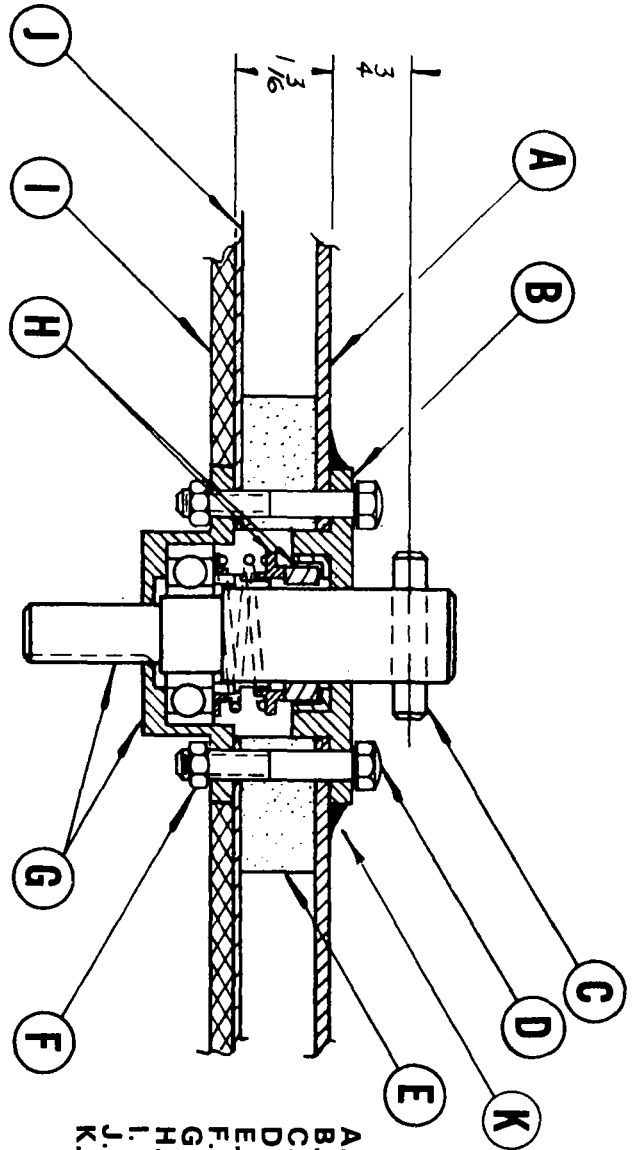

FIG. 11 LOWER BEARING AND SEAL ASSEMBLY.

1. Lower bearing shaft pin.
2. Lower bearing housing seal.
3. Lower bearing mounting bolt.
4. Lower bearing housing seal and seat.
5. Lower bearing housing.
6. Lower bearing mounting nut.



- A. Drain pan assembly.
- B. Housing-lower seal.
- C. Pin, lower bearing shaft.
- D. Bolt $\frac{3}{8}$ -16 x $2\frac{1}{4}$ lg. acorn head.
- E. Lower liner spacer.
- F. Hex lock nut $\frac{3}{8}$ -16.
- G. Lower bearing housing assembly.
- H. Lower seal — with seat.
- I. Styrofoam $\frac{1}{4}$ x $12\frac{1}{8}$ x 44 lg.
- J. Lower liner pan.
- K. R.T.V. sealer — sealing "B" to inside of BIN.

REMOVING DECAL LIGHT FIXTURE (FIG. 6 ITEM 12)

1. Disconnect power from vending unit by turning key lock switch off (bottom right hand side).
2. Unplug the two lead double-tap connections. (Numbers 38 and 39) Fig. 12.
3. Loosen thumbscrews (2) and carefully slide light fixture out of position (See Fig. 6).
4. If a bulb is to be replaced, twist the same 90° and pull out.
5. After replacement, reverse the above procedure.
6. If light bulb fails to light up, proceed as follows:
 - a. Check for power.
 - b. Check bulb to be in proper socket position.
 - c. Replace starter (capacitor).
 - d. Replace ballast (Fig. 6 and 17).

REMOVING BUCKET PAN AND GRILL ASSEMBLY (Fig. 4 and 5)

1. Remove bucket housing melting tray and deposit on vender drain pan.
2. Loosen wingnuts (4) which hold the weight control switch assembly in place. Slide assembly down as far as possible.
3. Remove thumbscrews (2) and carefully slide bucket pan and grill assembly out of position. (Caution: Do not exert undue pressure upon bellow of weight switch control.)
4. To replace, reverse above procedure, sliding the front end in first, making sure that thumbscrews are tightly in position.

REMOVING WEIGHT CONTROL SWITCH ASSEMBLY (Fig. 13)

1. Disconnect power from vending unit by turning key lock switch off (bottom right hand side).
2. Unplug the two lead double tap connectors (Numbers 40 and 41).
3. Remove four (4) wingnuts and lift assembly out of position.
4. To replace, reverse the above procedure.
5. For best operating position, consult mounting instructions on Page 2.

REMOVING TIMER BOARD OR POWER RELAY CR1 (Fig. 4)

1. Disconnect power from vending unit by turning key lock switch off (bottom right hand side).
2. Remove cover from control box.
3. Pull CR1 relay off if defective (See Fig. 4).
4. Pull leads directly attached to the timer board.
5. Remove timer board from mounting track by pushing sides out of mesh of mounting track.
6. To replace, reverse above procedure. Make sure that all leads make contact and are neatly tugged away.
7. Check vender for proper operations. Simulate entire sequence of operations, also on empty vender bin by holding the pan and grill assembly up until an empty light is in evidence. Reset timer by actuating momentary switch on control box.

BUCKET PAN AND WEIGHT CONTROL SWITCH MOUNTING INSTRUCTIONS (Fig. 13)

After both the bucket pan/grill assembly and weight control switch assembly have been reassembled to their assigned position, proceed as follows with the proper setting.

1. Check for free movement on the part of the bucket pan and grill assembly.
2. Raise the weight control switch assembly until the bucket pan and grill assembly establishes a clearance of 1/32 inch with the bucket door retainer bracket. Tighten the four wingnuts holding the weight control switch assembly. NOTE: Make sure the assembly is mounted in a horizontal position.

WEIGHT CONTROL SWITCH ADJUSTMENT INSTRUCTIONS (Fig. 13)

The weight control switch determines the amount of ice augered into the ice bucket. Adjustments are necessary for either an over- or under-fill. Normally the control is factory set for a standard bucket to be filled top level. New dispensers leave the factory with the weight control calibrated at 3 lbs. But because of variation in the weight and size of buckets all servicemen need to make some final adjustments.

1. Remove melting tray pan and deposit on bin liner drain pan (See Fig. 4).
2. For more ice, turn adjustment screw clockwise (looking into screw); for less ice, turn adjustment screw counter-clockwise (See Fig. 13).
3. Test several bucket fillings.
4. Move melting tray pan underneath the ice bucket housing.

CLEANING INSTRUCTIONS

In place cleaning for ice storage bin and melting tray.

1. Dispense all the ice out of the storage bin.
2. Remove auger access door from bin liner by removing the 14 thumb screws (See Fig. 5). Remove balance of ice from bottom of storage bin.
3. Remove auger as shown in Fig. 5 on instructions under REMOVING AUGER ASSEMBLY, Page 13.
4. Scrub inside of bin and auger using a nylon scouring pad, brushes and a cleaning solution, such as Lime-a-Way from Economics Labs or Boss Brand Milk Stone Cleaner from Northern Laboratories. Rinse all parts with clear water.
5. Inside of bin and parts can be sanitized by rinsing with a solution of one teaspoon of Chloride Bleach in one gallon of water.
6. Reassemble unit. Let run for 5 to 6 hours before vending ice.
7. For cleaning ice cuber refer to cleaning instructions in Service Manual found inside instruction envelope received with ice cuber.
8. Remove ice cube melting tray located beneath pan and grill assembly. (See Fig. 4). This can be cleaned with same cleaning solution as used for inside of storage bin. Rinse with clear water and replace.

COIN ACCEPTOR CLEANING

1. Disconnect power from vender by turning key lock switch off. Also unplug coin-changer assembly.
2. Remove coin-acceptor from coin-changer by pushing two release latches up.
3. Dip coin-acceptor in hot soapy water, and agitate mildly to remove any gummy deposits.
4. Rinse assembly with clear hot water and let dry. Do not reassemble in wet condition. If available, use air hose for drying. (Note: Keep in a place free of dirt and foreign material.)

COIN CHANGER CLEANING

1. Remove coin-changer from vending unit by loosening three mounting screws, and lifting coin-changer out of position.
2. Remove screws (21) and switch wire protector (item 20). See Fig. 17. Remove three screws (19) and carefully lift the 5 cent chute cover (item 18) out of mesh. Also, gently lift wire assembly of 5 cent coin-switch over chute cover.
3. Remove 5 cent chute assembly, (item 17) and 25 cent coin chute in succession.
4. Clean all items in hot soapy water and wipe the backside of coin-changer chute assembly clean.
5. After allowing sufficient time for drying, reverse assembly procedure. Be sure the 5 cent coin-switch wire is properly assembled and has free movement.
6. Remove five screws (15) on the base and lift base chute (14) and bottom cover (12) out of position.
7. Clean loose items with hot soapy water and wipe pay-out slide, (item 11) (Do not disassemble from coin-changer) and surrounding area with wet rag.
8. Dry all cleaned surfaces and reverse assembly procedure. NOTE: Avoid spilling water onto any of the electrical components.
9. Make visual inspection of all parts coming in contact with coins. Blow or brush any accumulated dust from all usable surfaces.
10. Mount coin changer to vender and tighten screws. Snap coin-acceptor into assigned position. Plug in coin-changer and vender for ice delivery test run.

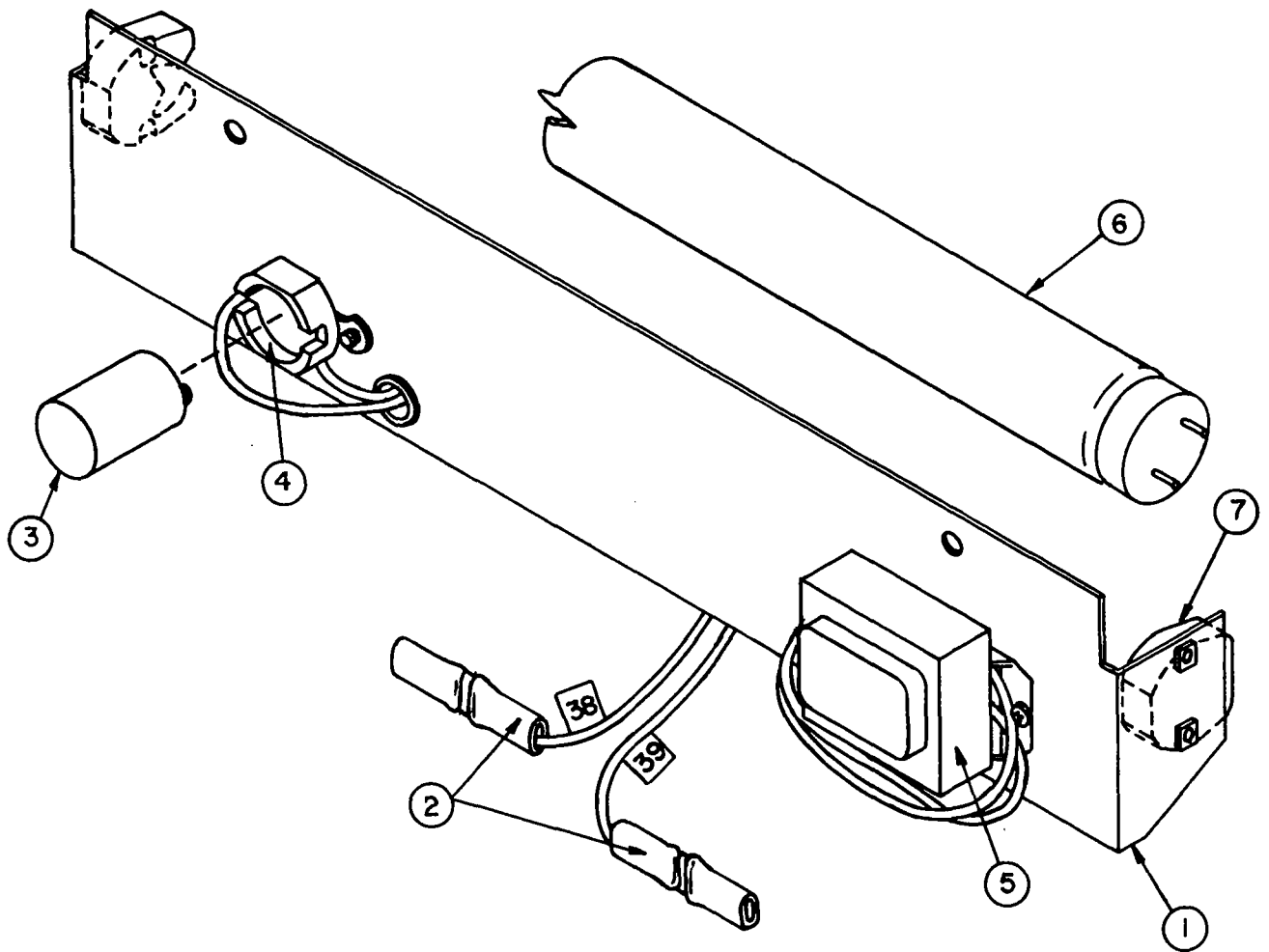
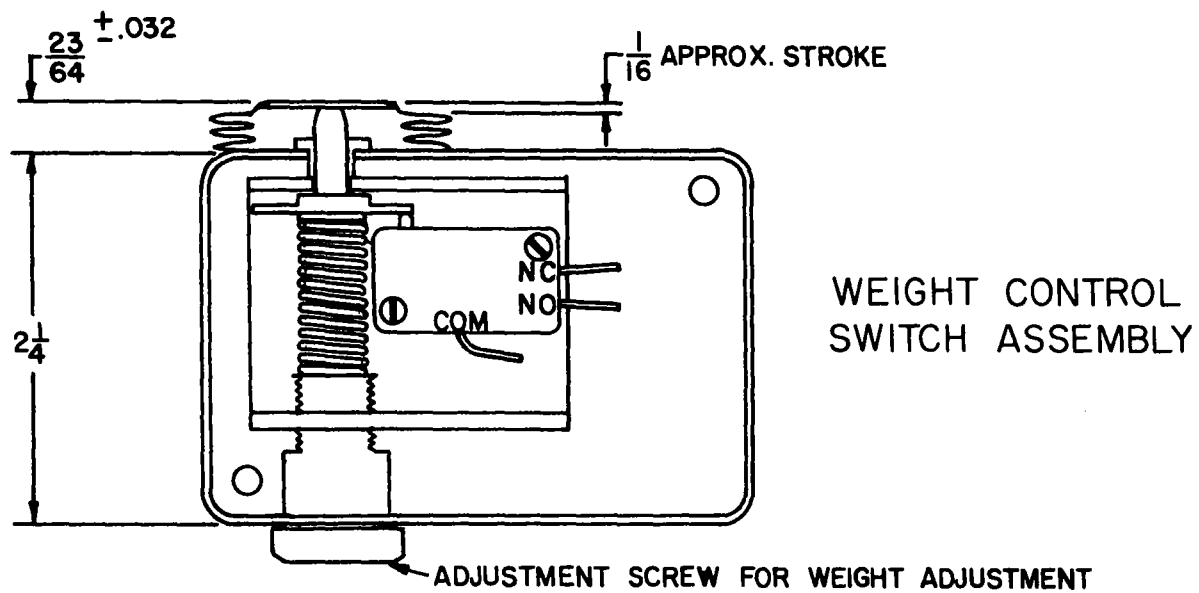
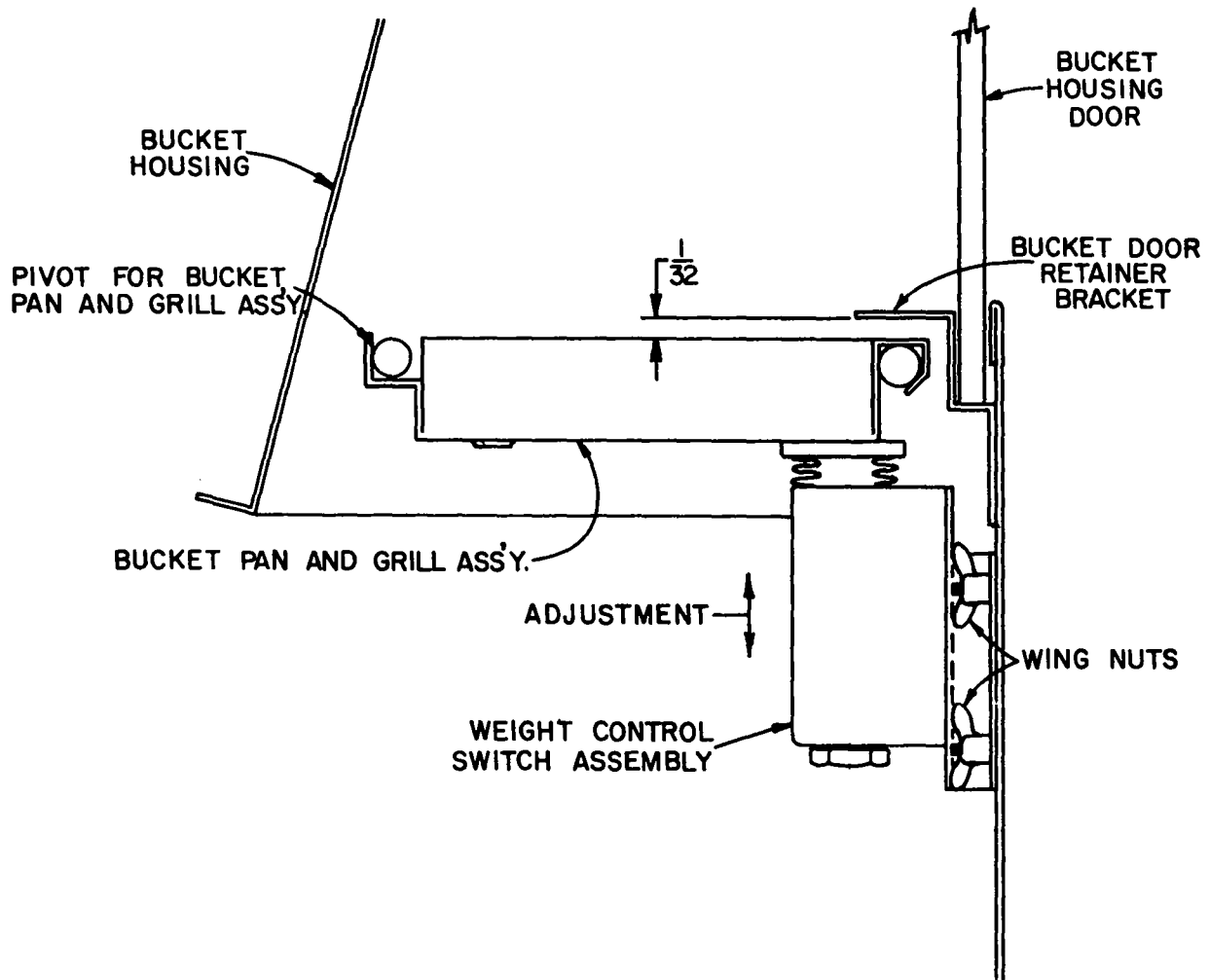

FIG. 12 DISPLAY LIGHT ASSEMBLY

1. Decal display light assembly.
2. Double tab connectors.
3. Starter.
4. Starter base.
5. Ballast.
6. Flourescent light bulb.
7. Lampholder.

FIG. 13 BUCKET PAN AND WEIGHT CONTROL SWITCH SETTING



SLIDING DOOR RETURN SPRING FIELD REPLACEMENT PROCEEDURE

1. REMOVE BROKEN SPRING FROM PLASTIC DRUM. (DO NOT REMOVE ARBOR)
2. UNWIND NEGATOR-SPRING FROM REPLACEMENT DRUM AS SHOWN.

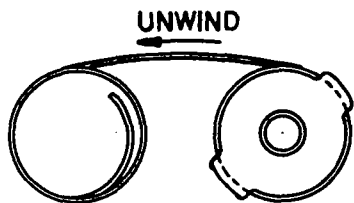

3. WIND A GOOD NEGATOR-SPRING BACK ONTO UNIT DRUM.

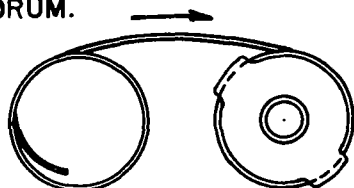

4. ATTACH SPRING-LEAF TO SLIDING DOOR WITH MACHINE SCREW AND WASHER.
5. ENSURE SMOOTH ROLLING ACTION OF SPRING BY MOUNTING HORIZONTALLY IN RELATION TO DRUM.

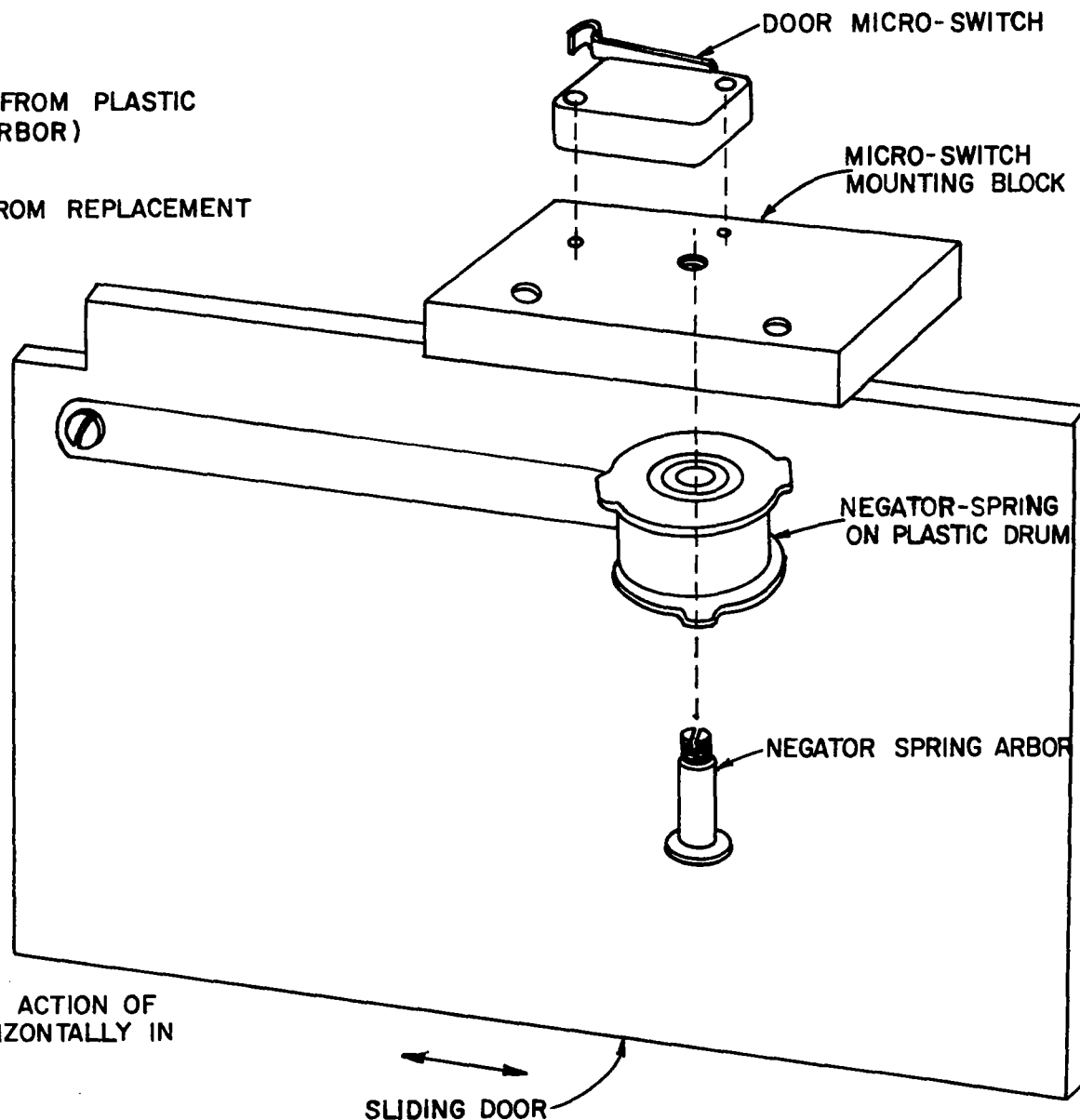
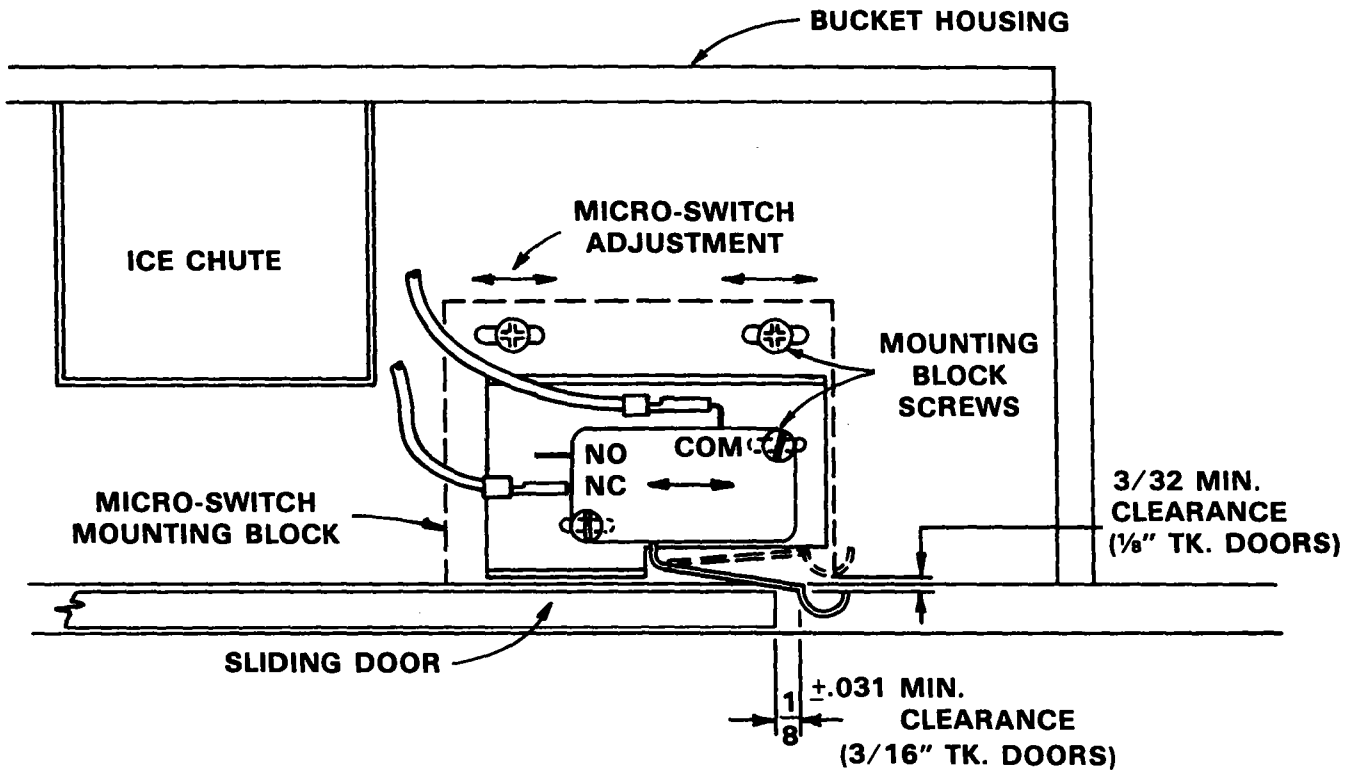

FIG. 15 SLIDING DOOR MICRO SWITCH ADJUSTMENT PROCEDURE



1. Move sliding bucket door into closed position.
2. Loosen four mounting block screws.
3. Adjust micro-switch into prescribed position.
Note: Allow for minimum clearance of micro-switch lever.
4. Tighten mounting block screws.
5. Check sliding door for free movement and switching operation.
6. Remove any obstacles if so required.

FIG. 16 COIN REJECTOR MECHANISM

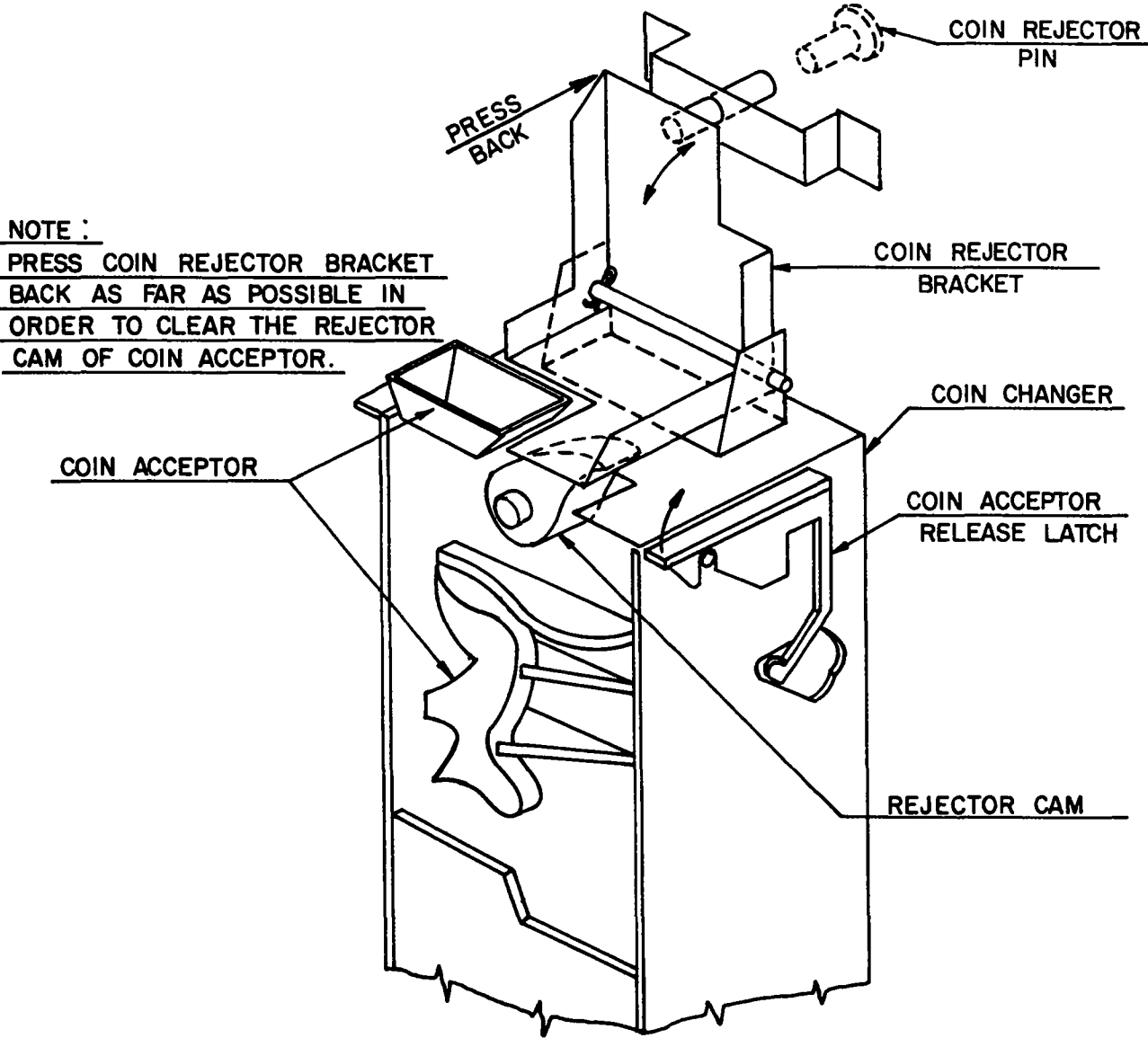
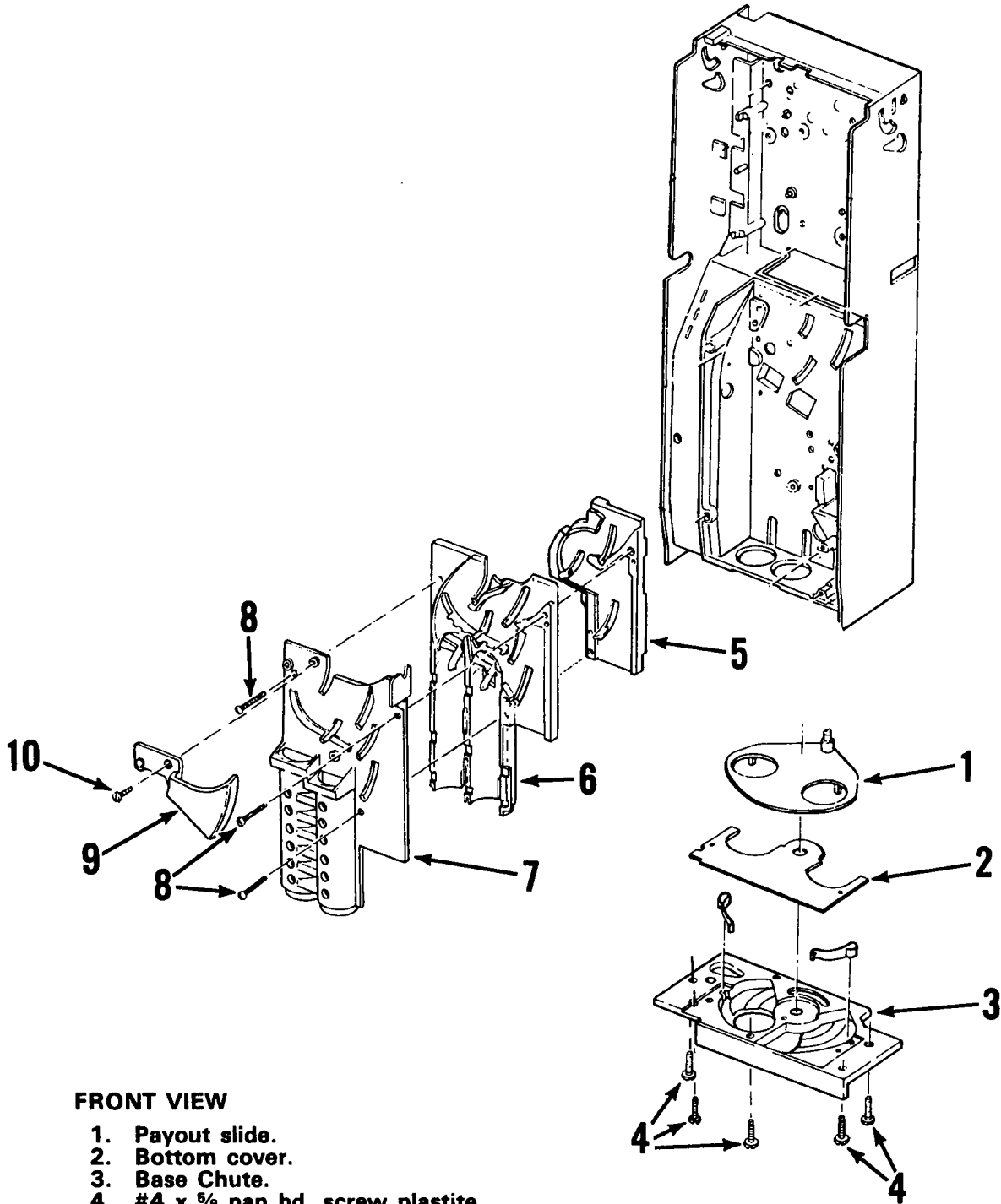

FIG. 17 COIN CHANGER AND PARTS REMOVED FOR CLEANING PROCEDURE



FRONT VIEW

1. Payout slide.
2. Bottom cover.
3. Base Chute.
4. #4 x $\frac{5}{16}$ pan hd. screw plastite.
5. 10-25¢ coin chute.
6. 5¢ chute assembly.
7. 5¢ chute cover.
8. #4 x $\frac{15}{16}$ pan hd. screw plastite.
9. Switch wire protector.
10. #4 x $\frac{5}{16}$ pan hd. screw plastite.

The following list is provided to help give you services for the coin mechanisms used in the AC-0370 dispensers.

COINCO BRANCHES AND SERVICE CENTERS

ARIZONA
Coin Acceptors, Inc.
1911 E. McDowell Road
Phoenix, Arizona 85006
Phone No. (602) 253-1088

LOUISIANA
Coin Acceptors, Inc.
3207 Dublin Street
New Orleans, Louisiana 70118
Phone No. (504) 488-3738

NORTH CAROLINA
Coin Acceptors, Inc.
3127 Tuckasegee Road
Charlotte, North Carolina 28208
Phone No. (704) 394-0123

WASHINGTON
Coin Acceptors, Inc.
6206 Eighth Ave. N.W.
Seattle, Washington 98107
Phone No. (206) 784-2707

CALIFORNIA
Coin Acceptors, Inc.
1590 Gilbreth Road
Bulingame, California 94010
Phone No. (415) 697-7416
(415) 697-2013

MARYLAND
Coin Acceptors, Inc.
1724 Russell Street
Baltimore, Maryland 21230
Phone No. (301) 685-2787

OHIO
Coin Acceptors, Inc.
4740-P Dues Drive
Cincinnati, Ohio 45246
Phone No. (513) 874-4460

CANADA
Coin Acceptors, Canada
No. 3-590 West Broadway Ave.
Vancouver 9, British Columbia
Phone No. (604) 873-2343

Coin Acceptors, Inc.
1537 East Washington Blvd.
Los Angeles, California 90021
Phone No. (213) 747-8878

MASSACHUSETTS
Coin Acceptors, Inc.
225 Crescent Street
Waltham, Massachusetts 02154
Phone No. (617) 894-4525

PENNSYLVANIA
Coin Acceptors, Inc.
3345 Evergreen Road
Pittsburgh, Pennsylvania 15237
Phone No. (412) 366-6100

Coin Acceptors, Canada
189 Rockland Rd.
Town of Mount Royal,
(Montreal), Quebec
Phone No. (514) 342-4664

COLORADO
Coin Acceptors, Inc.
3895 Forest St.
Denver, Colorado 80207
Phone No. (303) 322-1053

MICHIGAN
Coin Acceptors, Inc.
10631 Dix Avenue
Dearborn, Michigan 48120
Phone No. (313) 843-1600

TENNESSEE
Coin Acceptors, Inc.
905-5 East Brooks Road
Memphis, Tennessee 38116
Phone No. (901) 398-3157

Coin Acceptors, Canada
868 Progress Ave.
Scarborough, (Toronto) Ontario
Phone No. (416) 438-6314

FLORIDA
Coin Acceptors, Inc.
1117 S. 21st Ave.
Hollywood, Florida 33020
Phone No. (305) 922-8086

MINNESOTA
Coin Acceptors, Inc.
4921 Central Ave. N.E.
Columbia Heights
Minneapolis, Minnesota 55421
Phone No. (612) 571-7753

TEXAS
Coin Acceptors, Inc.
2936 Reward Lane
Dallas, Texas 75220
Phone No. (214) 358-5605

Coin Acceptors, Canada
902 St. James Street
Winnipeg, Manitoba
Phone No. (204) 786-3086

Coin Acceptors, Inc.
3103 E. Seventh Ave.
Tampa, Florida 33605
Phone No. (813) 248-5706

MISSOURI
Coin Acceptors, Inc.
5006 Daggett Ave.
St. Louis, Missouri 63110
Phone No. (314) 531-7662

Coin Acceptors, Inc.
2183 Portsmouth St.
Houston, Texas 77098
Phone No. (713) 526-4601

JAPAN
Nippon Coinco Co. Ltd.
18th Floor, Hazama Building
5-8, Kita Aoyama, 2 Chome
Minato-Ku, Tokyo 107, Japan
Phone No. 03-405-7431

GEORGIA
Coin Acceptors, Inc.
4215 Wendell Drive S.W.
Suite 110
Atlanta, Georgia 30336
Phone No. (404) 691-2777

NEW YORK
Coin Acceptors, Inc.
23-10 44th Drive
Long Island City, New York 11101
Phone No. (212) 361-1451

UTAH
Coin Acceptors, Inc.
1479 S. Main St.
Salt Lake City, Utah 84115
Phone No. (801) 467-4554

PUERTO RICO
Coin Acceptors, Inc.
P.O. Box 174
Quebradillas, Puerto Rico 00742
Phone No. (809) 895-2290

ILLINOIS
Coin Acceptors, Inc.
4450 N. Central Ave.
Chicago, Illinois 60630
Phone No. (312) 725-4483

SERVICE AND PARTS PROCEDURES

ORDERING PROCEDURE

Replacement parts for Manitowoc ice machine equipment should be ordered directly from your local Manitowoc Ice Machine distributor. Parts are stocked by the distributor in order to provide prompt and efficient service for ice machines sold in their areas.

Should you encounter difficulty in locating a Manitowoc distributor in your area, contact Manitowoc Service Parts Dept. for the name or names of distributors in your area.

When placing your order, be sure to do as follows:

1. Print name and address plainly.
2. If special routing is requested, please show the name of the carrier.
3. Indicate quantity desired, print catalogue part number plainly and print name as shown in the catalogue.
4. Indicate model and serial number of the unit. The complete serial number is needed.
5. If uncertain as to the proper part number, please give a complete description or sketch of the part and

the location of the part which is needed.

6. Check to see that all required information is contained in your order to facilitate prompt shipment. All replacement parts shipped from the factory on a f.o.b. Manitowoc basis. It is company policy to bill for all field replacement parts, according to terms as specified by our Credit Department.

Transportation companies are responsible for damage in transit as all shipments are tendered to them in good condition; and our responsibility ceases upon receipt of a signed bill of lading from the carrier. If the shipment arrives in a damaged condition or is short, the delivery carrier should be notified immediately.

RETURN OF DEFECTIVE PARTS

All defective parts returned to the factory, transportation prepaid, must be properly packaged to prevent further damage and tagged with a return material tag properly filled in. It is especially important that the cabinet serial number be secured and recorded on the tag, securing as much information as possible about the nature of the defect to prevent any delays in issuing credit. All parts should be returned as they are removed from the cabinet and not mutilated or tampered with. The return material tags are provided on a no-charge basis by the factory upon receipt of your request. Upon the receipt of these parts here at the factory, they will be inspected; and if they are found to be defective, in material and workmanship, under normal use and service, credit will be issued. Any part not properly packaged will be returned to the sender freight collect and no credit will be issued.

IMPORTANT: All warranty parts must be returned to the dealer from whom the replacement part was purchased. The dealer will return the part to the factory.

Our warranty and protection plan does not apply to cabinets that are not registered; therefore, it is necessary that, upon completion of the installation of the cabinet, the registration card be signed on the date of installation and mailed promptly to the factory Service Department in order for the cuber to be registered.

RETURN OF HERMETICALLY-SEALED UNITS

Extreme care should be used in servicing the hermetically-sealed mechanism. It is important that the trouble be correctly determined before the unit is changed. Be sure it is not the control, relay, or overload causing the trouble. The defect must be listed on the return material tag. Hermetically-sealed units must be returned with service valves closed and capped. All lines must be pinched and soldered shut.

RETURN OF COMPLETE MACHINES

Complete machines may not be shipped back to the factory for repairs without first securing prior permission from the factory. If an unauthorized missing shipment is received at the factory it will be refused by our warehouse and immediately returned to the sender. Upon receipt of your request to return a cabinet, if we feel that your request is legitimate, you will be sent an authorized return label authorizing you to return this cabinet to the factory freight prepaid.

When returning water cooled models, make sure all water lines are blown out before returning ice cuber to prevent lines from freezing during cold weather.

SERIAL NUMBER NOMENCLATURE

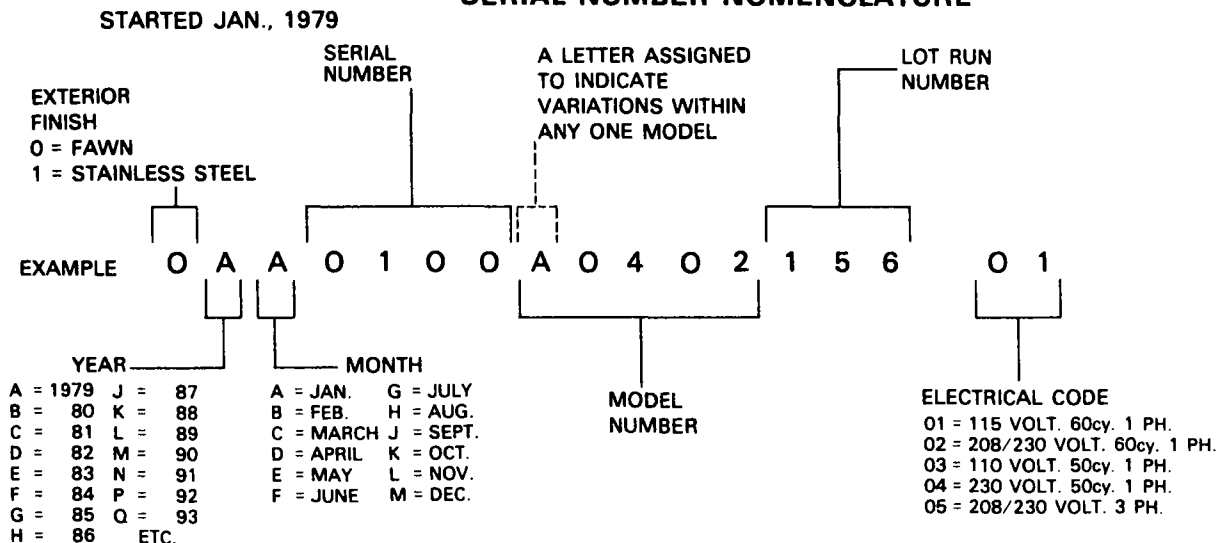

Ice Machine and Bin Warranty

From the date of original installation, we do hereby warrant each new Ice Machine and Bin to be free from defects in material and workmanship, under normal use and service, for a period of one year, and four additional years on the hermetic motor compressor in the Ice Machine.

Our obligation under this warranty is limited solely to correcting or replacing without charge at the factory in Manitowoc, Wisconsin any part or parts of this equipment which shall have been returned, transportation prepaid, and which our examination discloses to our satisfaction to be defective.

This warranty does not apply to any equipment that has been damaged by flood, fire, or suffered abuse, misuse, neglect or accident, or to any Ice Machine which has been altered so as to affect performance or reliability, except where such alteration has been accomplished with our prior written consent.

We further limit this warranty in that we shall not be held liable under this contract for any special, indirect, or consequential damages whatsoever resulting from any defect in material and workmanship which interferes with the normal use and service of such Ice Machine and Bin.

This warranty is a complete and exclusive statement of all terms of the agreement between the Manitowoc Equipment Works and the owner of the equipment, and all representations of the parties. This agreement shall not be varied, supplemented, qualified or interpreted by any prior course of dealing between the parties or by any usage of the trade.

Sales are made on the express understanding that there are no express or implied warranties other than the express warranty herein contained and that there are no implied warranties that the goods shall be merchantable or fit for a particular purpose other than the expressed one year and five year warranty set forth above.

To validate this warranty, the registration card must be signed on the date of installation and mailed promptly to the Manitowoc Equipment Works, Manitowoc, Wisconsin.

DEALER _____

INSTALLATION DATE _____

MANITOWOC EQUIPMENT WORKS
(A division of The Manitowoc Co., Inc.)
2110 South 26th St., Ph: 414-682-0161
Manitowoc, Wisconsin 54220