

# Manitowoc

## AM-0650 SERIES ICE DISPENSER

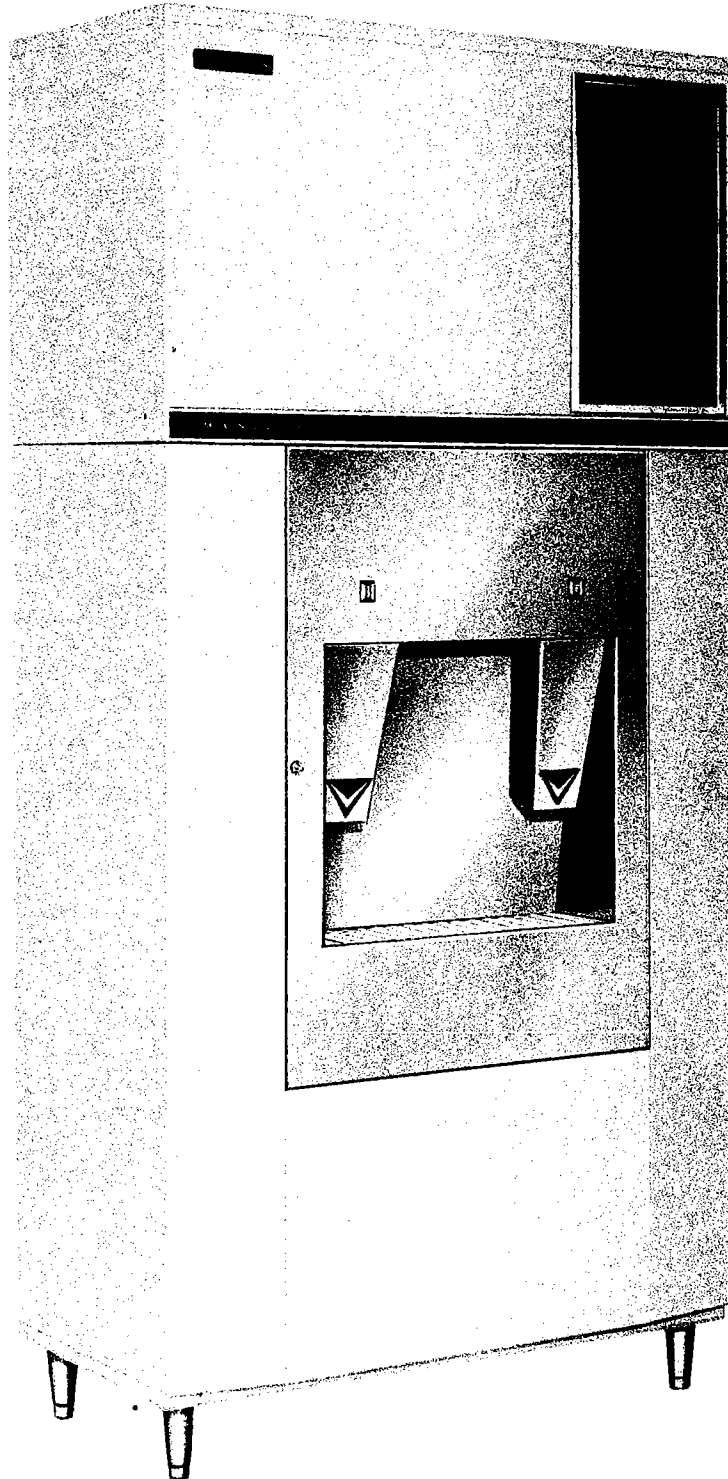

**Manitowoc** equipment works **MANITOWOC WISCONSIN**

Division of The Manitowoc Company, Inc.

10-79  
80-0049-3  
Rev. Jan. 1982

TABLE OF CONTENTS

Forward .....	Page 1
Uncrating and Inspection .....	Page 2
Ice Cuber Rear Mounting Clips .....	Page 2
Mounting Front of Ice Cuber to Dispenser .....	Page 2
Location and Installation .....	Page 2
Opening Front Door Panel .....	Page 2
Removing Lower Front Panel .....	Page 2
Electrical Connections .....	Page 3
Serial and Electrical Plate .....	Page 3
General Requirements .....	Page 3
Connecting Power Supply to Ice Dispenser .....	Page 3
Connecting Power Supply to Ice Cuber .....	Page 3
Connecting Dispenser Bin Water Drain Lines .....	Page 3
Connecting Water Supply to Ice Cuber .....	Page 3
Check List for Starting Ice Cuber .....	Page 3
Final Check List for Dispenser Bin .....	Page 3
How the Dispenser Works .....	Page 4
Optional Bin Components .....	Page 4
Key Operated Lock-Out Switch .....	Page 4
Removing Lock-Out Switch .....	Page 5
Removing Motor and Gear Drive Assy. ....	Page 5
Removing Electric Motor From Gear Reducer .....	Page 5
Gear Reducer .....	Page 5
Removing Auger Assy. ....	Page 6
Push Button Ice Control .....	Page 6
Transformer .....	Page 6
Upper Bearing Assy. ....	Page 6
Lower Bearing Assy. ....	Page 6
Dimensions and Specifications .....	Page 7-8
Fig. 1 — .....	Page 9
Fig. 2 — .....	Page 10
Fig. 3 — .....	Page 11
Fig. 4 — .....	Page 12
Fig. 5 — .....	Page 13
Fig. 6 — .....	Page 14
Fig. 7 — .....	Page 15
Fig. 8 — .....	Page 16
Fig. 9 — .....	Page 17
Fig. 10 — .....	Page 18
Fig. 11 — .....	Page 19
Fig. 12 — .....	Page 20
Fig. 13 — .....	Page 21
Fig. 14 — .....	Page 22
Fig. 15 — .....	Page 22
Fig. 16 — .....	Page 23
Fig. 18 — .....	Page 24
Fig. 19 — .....	Page 25
Junction Box Hook-Up AM0661 to 662 .....	Page 26
Wiring Diagram — AM0661 and 662 .....	Page 27
Junction Box Hook-Up AM0651 and 652 .....	Page 28
Wiring Diagram — AM0651 and 652 .....	Page 29
Wiring Diagram & Junction Box Hook-Up — AM0654 .....	Page 30
Service Analysis .....	Page 31
Cleaning Instructions .....	Page 31
Service and Parts Procedure .....	Page 32
Warranty .....	Page 33

**FORWARD**

Manitowoc Equipment Works, Division of The Manitowoc Company, Inc., Manitowoc, Wisconsin, presents this Service Manual to assist the serviceman with information concerning Construction, Installation and Maintenance of the MANITOWOC AM-0650 ice dispenser.

The problems of the user and the serviceman have been given special emphasis in the development of the latest Manitowoc ice machines and dispensers.

If you encounter a problem which is not answered by the manual, please feel free to write or call the service Department of the Manitowoc Equipment Works, Division of The Manitowoc Co., Inc., Manitowoc, Wisconsin 54220, describing the problem you have encountered. The Service Department will be happy to give you particularized advice and assistance. Whenever calling or writing, please state the complete model and serial number of the ice making & ice dispenser equipment.

**MODELS**

This manual covers the following models.

AM-0651	AM-0661
AM-0652	AM-0662
AM-0654	

Please refer to the Ice Cuber Service Manual for additional information required regarding installation, maintenance and servicing of the following ice cuber models which are adaptable to the Ice Cube Dispenser Bjns.

AD-602A	AD-603W
AD-1102A	AD-1103W

**WARRANTY**

Parts and Material	One year — parts only
Compressor	Five years — parts only

Defective parts must be returned transportation prepaid.

(See "Ice Machine and Bin Warranty" page 33 and registration card shipped with the unit for warranty conditions.)

## UNCRATING & INSPECTION

The AM-0650 ice cube dispenser bin is shipped to you in a heavy cardboard carton to help prevent damage in transit. Upon delivery of the ice dispenser, inspect the carton thoroughly before signing the freight bill and uncrating and dispenser. If the carton should show signs of rough handling have delivering carrier note freight bill that possible damage may exist.

To uncrate the Dispenser remove banding along the lower bottom edge of the carton. Remove the carton by sliding up and off of dispenser. Remove the four (4) corner posts and inner carton. Inspect dispenser for possible concealed damage. If damage is evident notify carrier at once for their inspection. Be sure to hold carton for their inspection. Upon completion of their inspection file a freight claim with the delivering carrier.

Remove the four skid bolts from bottom of skid and remove skid. Unpack the four 606 adjustable legs shipped with dispenser. Screw the 606 legs into the same holes in bottom of dispenser. These are the same holes that the skid bolts were removed from.

## ICE CUBER REAR MOUNTING CLIPS

To secure the ice cuber to the Dispenser bin you will find two rear mounting clips and six 8x1½" mounting screws packaged separately and taped to the box of 606 legs. The box of 606 legs is taped to the Dispenser base inside the Dispenser. See Fig. 4.

After ice cuber has been properly mounted on top of Dispenser, drill clip mounting holes into ice cuber base and dispenser (See Fig. 6). Use #8 x ½ sheet metal screws packaged with the clips and mount the clips to rear of the ice cuber and dispenser.

## MOUNTING FRONT OF ICE CUBER TO DISPENSER

Once the ice cuber has been properly mounted on Dispenser use the two holes in the dispenser bin top rail as shown in Fig. 5 to drill two holes in bottom of ice cuber base. Using two sheet metal screws front of ice cuber can be secured to Dispenser.

## LOCATION & INSTALLATION

After legs are securely in place, locate Dispenser Bin in desired location. Be sure to allow enough height for the ice cuber section to be installed on top of Dispenser bin.

Once Dispenser bin is located, allow a minimum of 5 inches on all sides for air circulation. If the 1100 Series ice cuber is to be used with the dispenser there must be a minimum of 18" from the back of the dispenser to the wall. Level bin side to side and front to back. Remove all shipping tape and packaging from bin.

Unlock and swing open stainless steel front door (Fig. 4). Remove the 18 thumb screws fastening auger access panel to front of bin liner (Fig. 4). Remove wooden shipping wedges placed between top of augers and upper bearing assy. These wedges are to hold augers in place during shipping (See Fig. 5).

Uncrate your Manitowoc ice cuber and refer to the Service Manual found in the instruction envelope packed inside the ice cuber. Carefully set the ice cuber on top of the Dispensing bin. Be sure cuber is set squarely on the Dispenser bin to insure accurate ice delivery into the dispenser bin (See Fig. 1).

## OPENING FRONT DOOR PANEL

Insert key into front door panel lock (See Fig. 2). Unlock front panel and swing door open (See Fig. 3).

## REMOVING LOWER FRONT PANEL

Remove lower front panel (Fig. 1) by removing the four (4) knurled machine screws located on back side of lower front panel.

## ELECTRICAL CONNECTIONS

230 VAC — 60 Hertz — Single Phase (Requires separate outlet) 15 amps Max.

See ice cuber service manual for ice cuber electrical connections.

## SERIAL AND ELECTRICAL PLATE

The combined serial number and electrical plate is located on outside of the dispenser on upper right hand side front corner. Be sure to send complete model and serial number of your dispenser when calling or writing for parts or service.

## GENERAL REQUIREMENTS

All electrical and water supply and drain connections must conform to local codes.

## CONNECTING POWER SUPPLY TO ICE DISPENSER

Your cuber Dispenser should be connected to a separately fused circuit. Fuse size must not exceed maximum fuse size shown on the electrical plate.

All electrical wiring connected to your Dispenser must be rated equal to the minimum circuit ampacity shown on the electrical plate.

Remove rear access panel (Fig. 6) and place No. 12 separately fused, 3 wire grounded cable, through the electrical supply hole (Fig. 6). Remove cover from electrical wiring box (Fig. 8) and connect the lead in wires to wires in electrical wiring box (Fig. 4). The two hot leads go to lead wires marked #1 and #7. Models with key lock out switch lead wires get connected to wires marked 1 and 12. See Pages 28 & 30. 3 wire green is ground wire and should be connected to ground screw, Page 28.

## CONNECTING POWER SUPPLY TO ICE CUBER

Refer to ice cuber service manual found inside instruction envelope found inside ice cuber.

## CONNECTING DISPENSER BIN WATER DRAIN LINES

Connect drain lines to the two ½" female pipe fittings in rear of the Dispenser (See Fig. 6). It is essential that drain connections be made so waste water cannot back up into the bin. Check all local plumbing codes. All Dispenser drain connections are labeled (See Fig. 6 & 7). Drain lines must be at least ½" inside diameter and have 1½" drop per 5 feet of run. We recommend covering all incoming water drain lines with a plumbing insulation material to prevent condensation.

## CONNECTING WATER SUPPLY TO ICE CUBER

Refer to cuber service manual found inside instruction envelope inside ice cuber.

## CHECK LIST FOR STARTING ICE CUBER

Refer to service manual found inside instruction envelope inside ice cuber.

## FINAL CHECK LIST FOR DISPENSER BIN

1. Is Dispenser bin level? (Important)
2. Refer to ice cuber service manual and find check list for checking ice cuber.
3. Have wooden shipping wedges been removed from top of auger and upper bearing assy? (See Fig. 5)
4. Has owner been instructed on how to operate and clean ice dispenser and ice cuber?
5. Have warranty registration cards for both Dispenser and Ice Cuber been filled out properly and mailed to our Service Dept. This is for the owner's protection in order that equipment can be registered to validate the warranty.
6. Has electrical box cover been replaced?

## HOW THE DISPENSER WORKS

The AM-0650 Series Dispensers are designed to be used with only one of the following Manitowoc model Ice Cubers.

AD-602A	AD-603W
AD-1102A	AD-1103W

These ice cubers manufacture the dice cubes and are the only model ice cubers that will operate on the AM-0650 Series Dispenser bin.

After the combination ice cuber and dispenser bin are installed, allow the ice cuber to operate 5 to 6 hours before dispensing ice. When this time period has elapsed there will be a sufficient amount of ice in the Dispenser Bin to enable the ice to be dispensed.

To dispense the ice place container directly under the Dispenser spout. Push either the right hand or left hand ice control button to begin ice delivery. When required amount of ice is delivered, merely release the ice control button to discontinue ice delivery.

The ice cuber delivers its ice into the Dispensing Bin in its normal manner. The 4 inch augers by revolving conveys the ice up to the ice chute opening. The ice then falls through this opening into the Dispensing spout and into the container.

The augers are driven at a slow RPM by a ¼ HP motor through a speed reducing gear train located in the compartment below the ice storage bin (See Fig. 7).

The opening in the ice delivery chute is designed to reject ice cubes, frozen together, to avoid jamming of the ice chute opening. These rejected cubes are either sheared by the chute or are dropped off the auger back into the bin to be re-dispensed.

Model AM0651 has two ice dispensing spouts and two ice button controls. When pushing R.H. ice button control ice will be delivered from the R.H. ice spout. When pushing L.H. ice button control, ice will be delivered from L.H. ice spout.

Model AM0661 Dispenser has only one ice dispensing spout and a Right hand and Left hand ice button control. When pushing either of the ice button controls both Right hand and Left hand gear drive motors will operate.

When ice is dispensed from the bin it is replaced by the ice cuber as per the specification charts on Page 8.

This continual falling of ice into the storage bin, keeps the ice loose for maximum dispensing capacity of the dispenser.

The water created by some melting of the ice is drained out through the bin drain connections located in rear of the Dispenser (See Fig. 6). Condensation forming on the outside of the storage bin will run down into the bin base drain pan and out through the base drain connection located in the rear of the dispenser (See Fig. 4 & 6).

## OPTIONAL BIN COMPONENTS, See Chart on Page 7

### KEY OPERATED LOCK-OUT SWITCH

A key operated lock-out switch was added to the AM0651 and 0661 starting with Serial Number 07413.

This key operated lock out switch will permit the customer to lock up the dispenser preventing the dispensing of ice. For location of key lock-out switch see lower right hand side front cover.

## REMOVING LOCK-OUT SWITCH

Should the lock-out switch need replacement proceed as follows:

1. Disconnect power to the Dispenser.
2. Remove lower front panel.
3. Remove switch box cover.
4. Remove switch wire leads and mtg. screws and remove switch. See Fig. 18.
5. To replace key lock remove lock retainer hex nut located in junction box and remove lock from outside of dispenser.

## REMOVING MOTOR & GEAR DRIVE ASSY.

To remove the complete auger drive motor and gear reducer from rear of the Dispenser for maintenance or replacement proceed as follows:

1. Unlock and swing open front stainless steel door.
2. Remove lower front panel (Fig. 1) by the four knurled screws located on backside of lower front panel and remove panel.
3. Remove rear access panel (Fig. 6) by removing the four mounting screws (Fig. 6).
4. Shut off power to Dispenser and disconnect power lead wires inside gear drive motor junction box (Fig. 8).
5. Remove bin support brackets from rear gear drive mtg. bracket (Fig. 7 & 9) and the two sheet metal screws holding bin support bracket to bottom of bin liner.
6. Loosen the four machine screws (Fig. 7 & 8) holding the front and rear mtg. brackets to gear reducer. This will allow the gear reducer and motor assy. to drop down partially disengaging the coupling. (Fig. 7 & 15) on the reducer drive shaft.
7. Loosen the set screws on both upper and lower halves of the coupling. Slide upper coupling up on lower bearing shaft so it will be out of the way.
8. Slide lower half of coupling up and off of the reducer drive shaft.
9. Remove the four machine screws mtg. front bracket to the gear reducer (Fig. 8).
10. Remove the four machine screws (Fig. 7 & 9) mtg. rear bracket to the dispenser base.
11. Complete gear reducer and motor with rear mtg. bracket can be removed from the dispenser through the rear access opening.
12. To reassemble reverse the above procedures in Item 11-10-9-8-7-6 and 5.

## REMOVING ELECTRIC MOTOR FROM GEAR REDUCER

1. Remove mtg. bolts holding electrical drive motor to gear reducer (See Fig. 7).
2. Using a slotted screw driver start to pry motor loose from gear reducer. Once separation has started screw driver will no longer have to be used since the assy. comes apart quite easily.

## GEAR REDUCER

The gear reducer has a red vent and fill plug located on top of the reducer (See Fig. 10). This plug is vented to prevent pressure from building up inside of gear reducer and blowing out the oil seals. Due to slow RPM of the gear reducer there should be no need to change the oil in the gear reducer.

Should the oil have to be replaced remove the red vent and fill plug and refill with 9 oz. of #600W Mobile oil.

Grease fitting on top of gear reducer is used in production to grease upper gear reducer bearing. Due to the slow RPM of gear reducer there should be no need to grease upper bearing on reducer.

### REMOVING AUGER ASSY.

To remove the auger assy. for cleaning or maintenance proceed as follows:

1. Unlock stainless steel front door and swing open (See Fig. 3).
2. Remove the 18 thumb screws fastening auger access door to bin liner (See Fig. 4) and remove auger access door.
3. Lift auger (Fig. 5) up to disengage bottom of auger from lower bearing drive shaft. Move bottom of auger to the side and pull down to disengage it from upper bearing assy. Auger assy. can now be removed from inside of the bin.
4. To reinstall the auger assy. reverse the above procedure. Make sure bottom end of auger is properly seated on lower bearing drive shaft at bottom of the bin.
5. Note that the slot on top of auger shaft is longer than slot on bottom of auger shaft.

### PUSH BUTTON ICE CONTROL

This ice control button when pushed starts gear drive motor causing auger to revolve conveying ice up to the ice chute opening and out into ice dispensing spout.

Should ice control button have to be replaced (See Fig. 16) and proceed as follows:

1. Unlock front S.S. door.
2. Shut off power to dispenser.
3. Remove switch box cover (Fig. 3).
4. Pull down and out on top of switch unit. Switch unit will separate from lamp housing.
5. Disconnect lead wire to switch unit and replace.
6. To reassemble reverse the above procedure.

To replace the ice control switch lamps (See Fig. 16) and proceed as follows:

1. Shut off power to dispenser.
2. From front of dispenser door grasp display screen with finger and pull out. Complete lampholder will come out. Lamps can be removed from the back side of lampholder. Replace lamp or lamps and push back into the door (See Fig. 2).

### TRANSFORMER

The purposes of the transformer is to reduce line voltage for lamps in ice control button.

Transformer is located in the electrical box mounted to the base of the Dispenser (See Fig. 4).

### UPPER BEARING ASSY.

Upper bearing assy. is located near the top of dispenser, above the auger (See Fig. 5). Remove the auger assy. then remove the three mounting bolts fastening bearing assy. to top liner support rail (See Fig. 5 & 13).

### LOWER BEARING ASSY.

Lower bearing assy. consists of a lower bearing housing, bearing, lower bearing shaft and pin, lower seal housing and lower seal (See Fig. 12). To disassemble the lower bearing assy. proceed as follows:

1. Auger out ice from dispenser.
2. Remove 18 thumb screws from auger access door and remove rest of ice from bottom of storage bin.
3. Remove gear drive and motor assy. as explained on Page 5 under heading REMOVING MOTOR & GEAR DRIVE ASSY.
4. Remove the three  $\frac{3}{8}$ -16 x  $2\frac{1}{4}$  lg. hex lock nut located at outside of bin liner in gear drive and motor compartment (See Fig. 11).
5. Remove three bearing mtg. bolts from inside of bin (See Fig. 12).
6. Remove drive pin from lower bearing drive shaft (See Fig. 12). These pins are in extremely tight so they will not work themselves loose. A hammer and drift pin will have to be used to remove it.
7. Lower bearing seal housing can now be removed from bottom of bin liner (See Fig. 12).
8. Lower bearing housing, shaft and lower seal can now be removed (See Fig. 12).
9. To replace reverse the above procedure. Make sure to use RTV sealer to seal lower bearing seal housing and lower bearing housing to bottom of bin liner (See Fig. 12).

**DIMENSIONS — AM-0651 Dispenser Bin With  
"600" Series Ice Cuber — 606 Adjustable Legs**

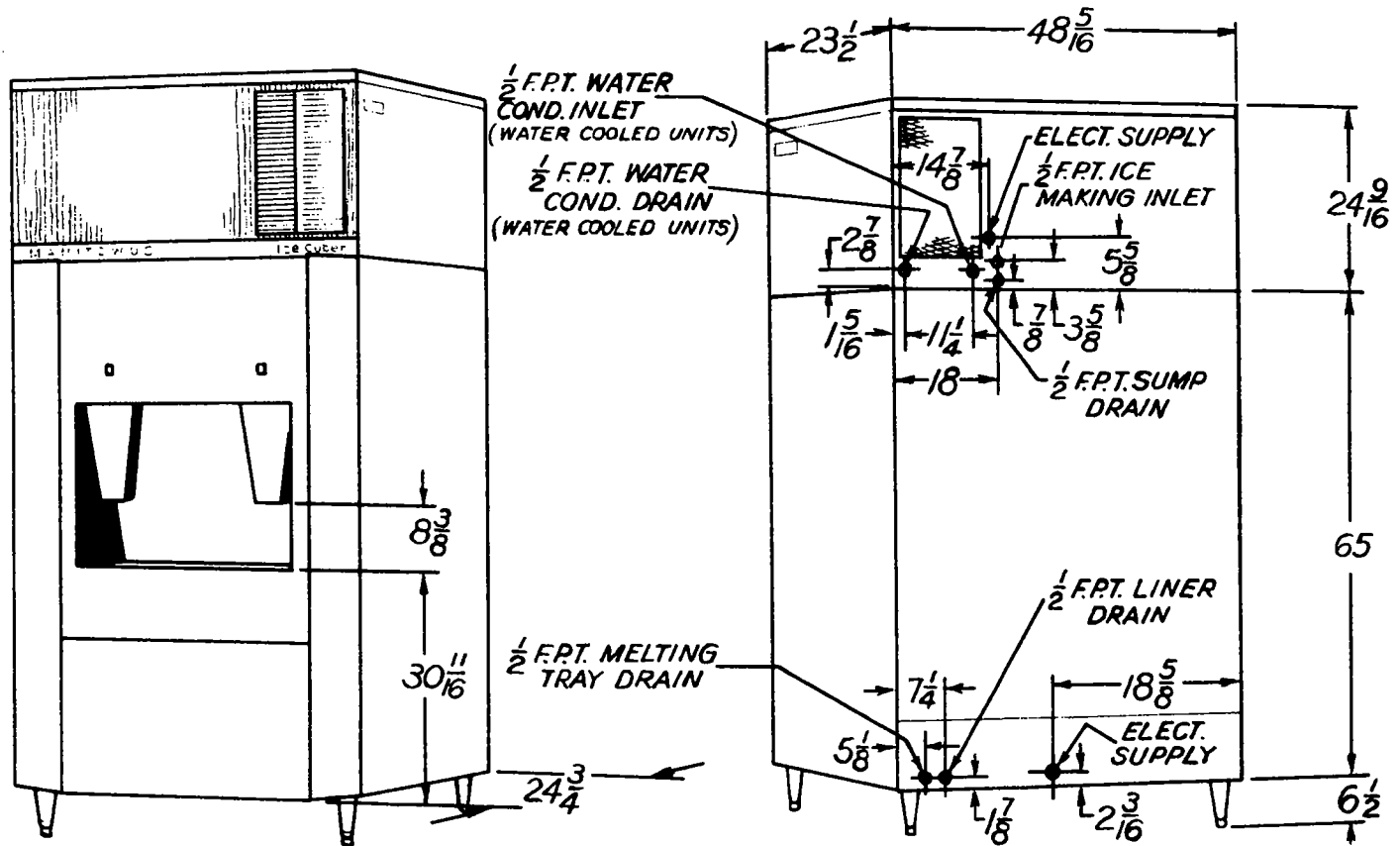

MODELS	AM-0651	AM-0652	AM-0654	AM-0661	AM-0662
TWIN DISPENSING STATIONS	*	*	*		
SINGLE DISPENSING STATION				*	*
PUSH BUTTON	*			*	
KEY		*			*
GLASS-TRIGGER ICE			*		
GLASS-TRIGGER WATER			*		
PORTION CONTROL			*		
8" HIGH BUCKET SPACE	*				
12" HIGH CARAFE SPACE	*				
RAPID FLOW				*	*

### Ice Making Section Specifications

"600" SERIES ICE PRODUCTION (Pounds per 24 Hours)	Incoming Water Temp. (F)		Room Temperature (F)		
			70°	80°	90°
	Air Cooled Unit	50° 70° 90°	590 550 510	540 500 460	490 450 410
Water Cooled Unit	50° 70° 90°	620 580 540	590 550 510	560 520 480	

"1100" SERIES ICE PRODUCTION (Pounds per 24 Hours)	Incoming Water Temp. (F)		Room Temperature (F)		
			70°	80°	90°
	Air Cooled Unit	50° 70° 90°	1040 920 820	940 850 770	880 790 700
Water Cooled Unit	50° 70° 90°	1100 950 880	1070 940 870	1030 930 850	

### Ice Making Section Dimensions

MODEL	"600" SERIES	
	AD-602A	AD-603W
Height	24-9/16"	24-9/16"
Width	48-5/16"	48-5/16"
Depth	23-1/2"	23-1/2"
Approx. Ship. Wt. (lbs.)	368	351
Compressor Size	1 H.P.	1 H.P.

MODEL	"1100" SERIES	
	AD-1102A	AD-1103W
Height	25-5/8"	25-5/8"
Width	48-1/4"	48-1/4"
Depth	23-5/8"	23-5/8"
Approx. Ship. Wt. (lbs.)	430	415
Compressor Size	1-1/2 H.P.	1-1/2 H.P.

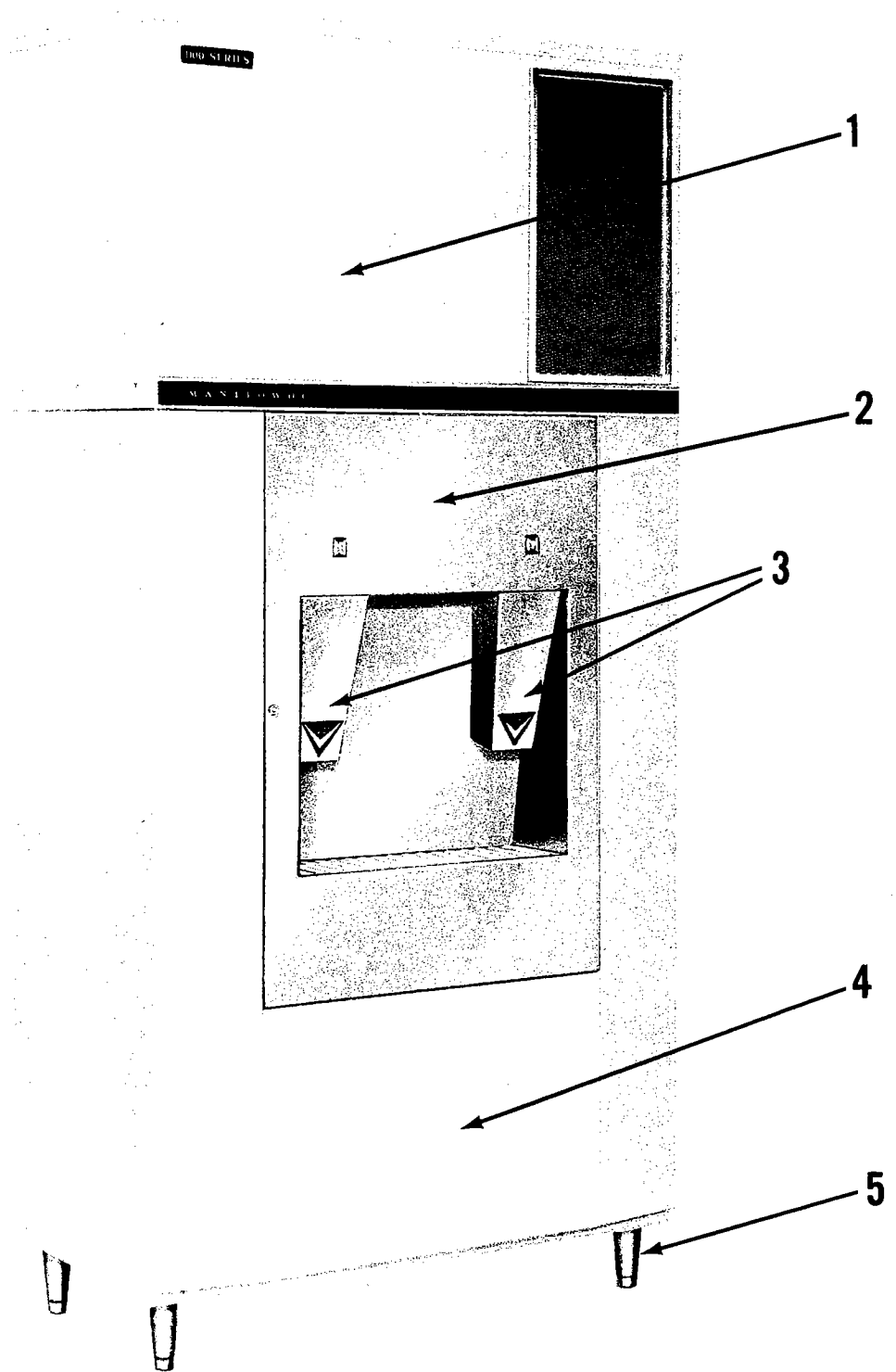
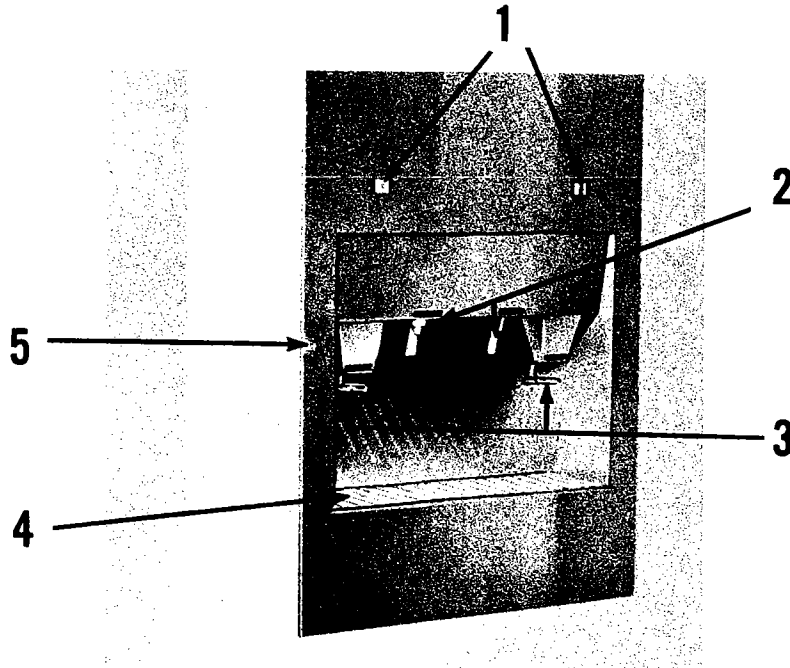

FIG. 1

1. 1100 Series ice making section.
2. Stainless steel front door and ice control switches.
3. Ice dispensing spouts (Series 651, 652).
4. Lower front panel (Gear drive & motor compt.).
5. 606 Legs.

FIG. 2



- 1. Push button.
- 2. Glass trigger water.
- 3. Glass trigger ice.
- 4. Grill.
- 5. Door lock.

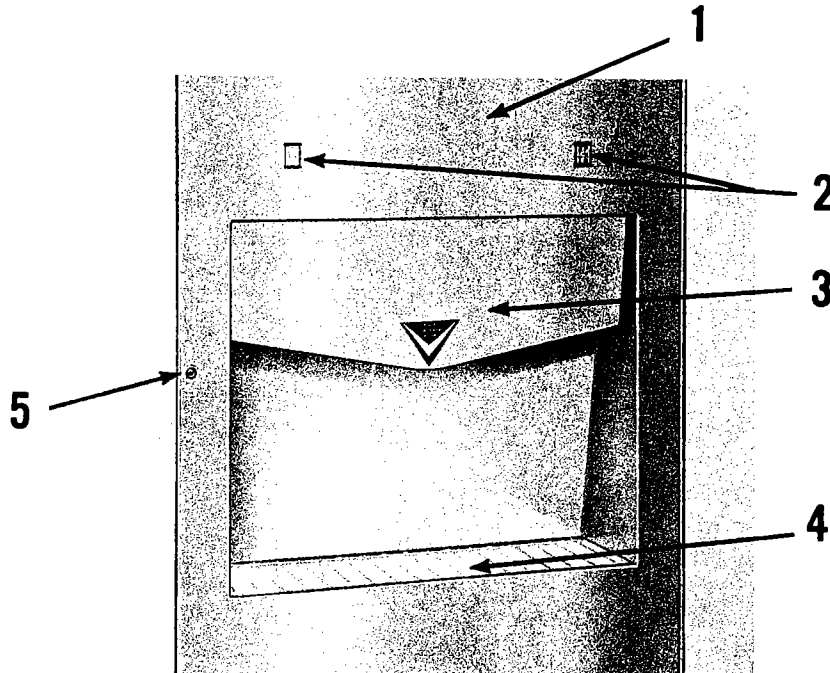

- 1. Stainless steel front door.
- 2. Ice control switches.
- 3. Single ice dispensing spout (Series 661, 662).
- 4. Wire grill.
- 5. Front door lock.

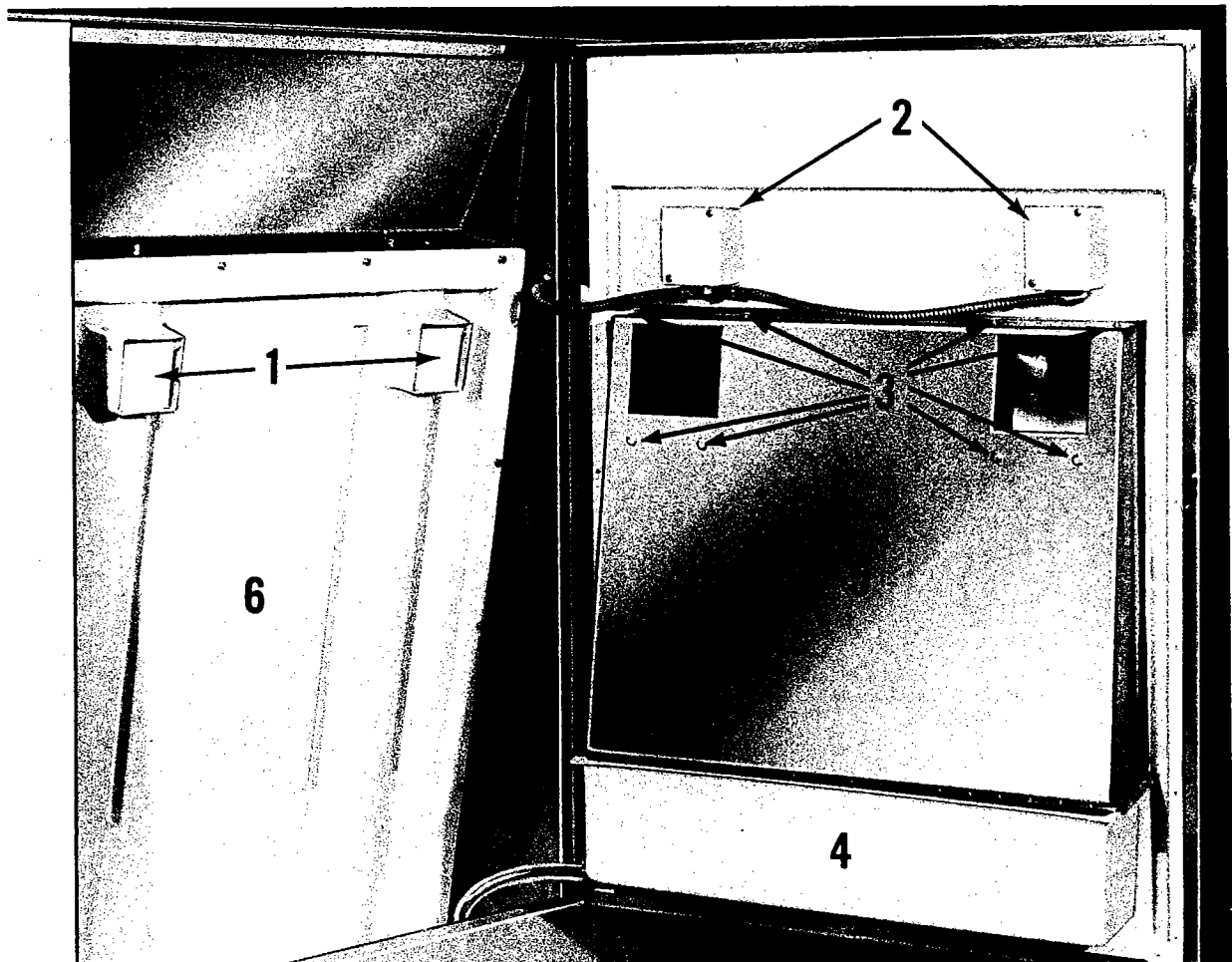

FIG. 3

1. Ice chute opening and damper doors.
2. Ice control switch box & cover.
3. Knurled machine screws for mtg. ice dispensing spout.
4. Melting pan.
5. Ice dispensing spout housing.
6. Auger access door.

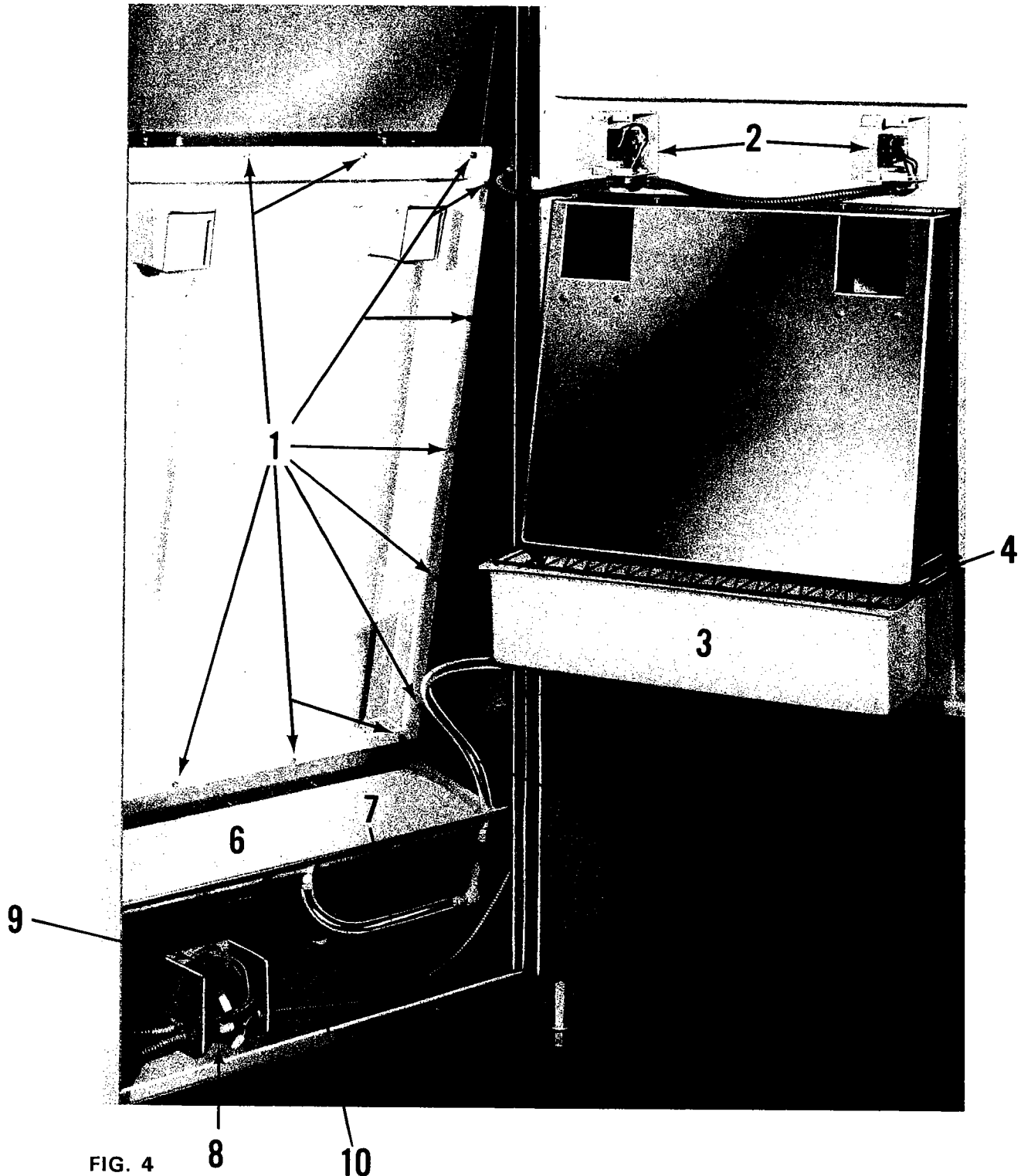

FIG. 4

- 1. Thumb screws holding auger access door to bin liner.
- 2. Control switch & housing with cover removed.
- 3. Ice cube melting pan.
- 4. Wire grill.
- 5. Tygon tubing to lower bin base drain pan.
- 6. Lower bin base drain pan.
- 7. Tygon tubing from lower bin drain pan to nylon tee.
- 8. Electrical wiring box.
- 9. Transformer for ice control switch.
- 10. 606 legs & ice cuber mounting clips located here for shipping.

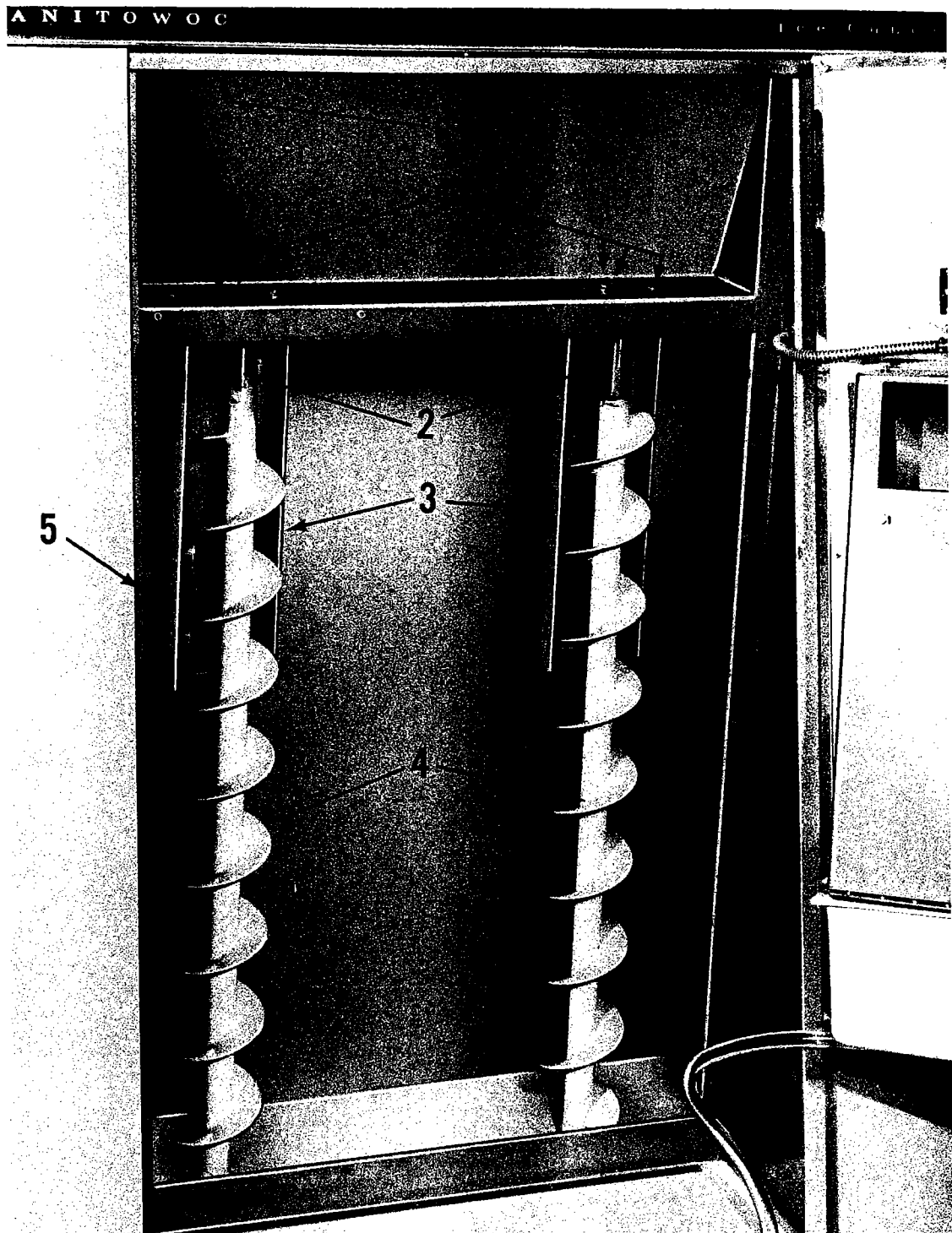

FIG. 5

1. Upper bearing mounting bolts & lock nuts.
2. Location of wooden shipping wedge that must be removed before operating dispenser.
3. Ice chute.
4. 4" augers.
5. Front door lock retainer plate.
6. Location of 2 front mtg. holes for mtg. ice cuber to bin. Holes are approx. 10" in from outside of dispenser.

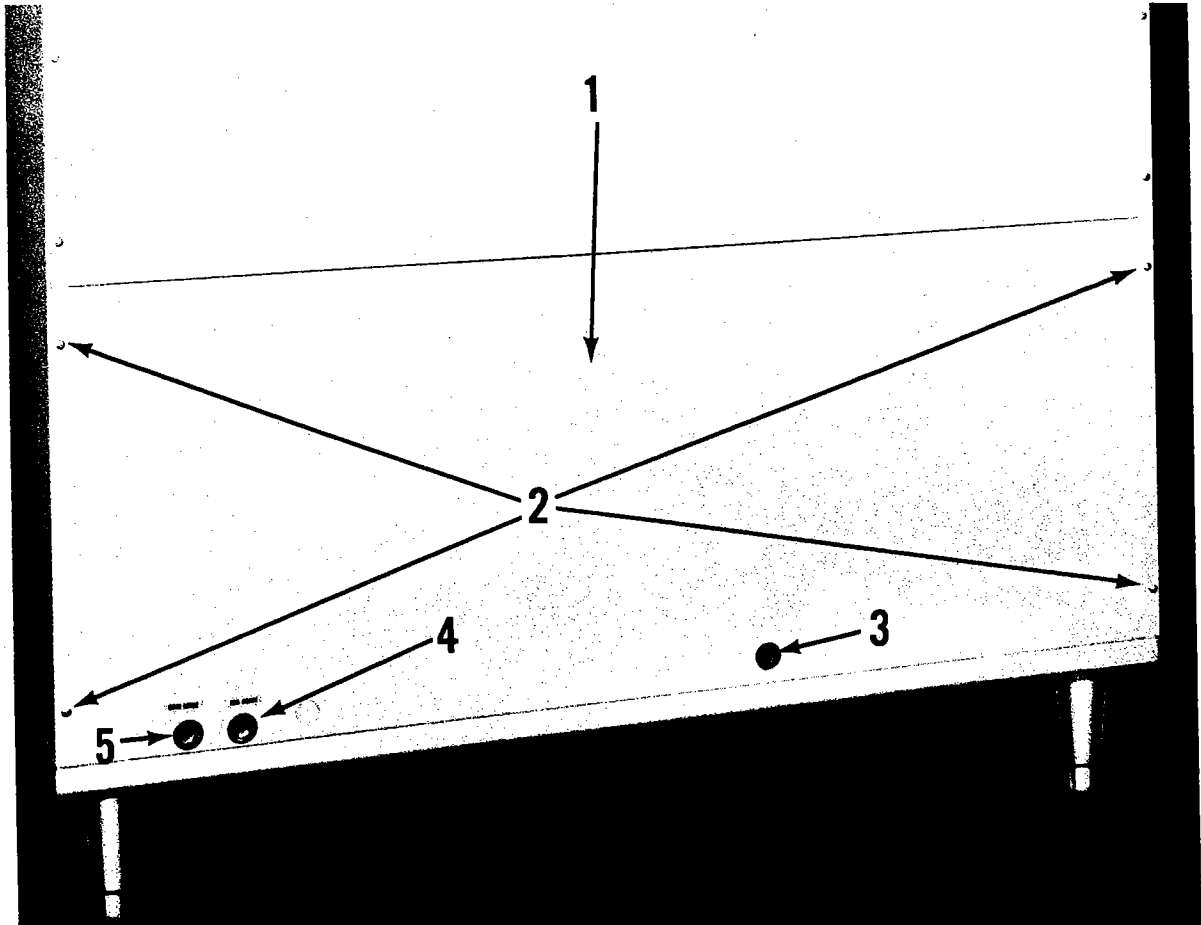

FIG. 6

- 1. Rear access panel.
- 2. Rear access panel mtg. screws.
- 3. Electrical supply inlet.
- 4. Bin drain.
- 5. Base drain.

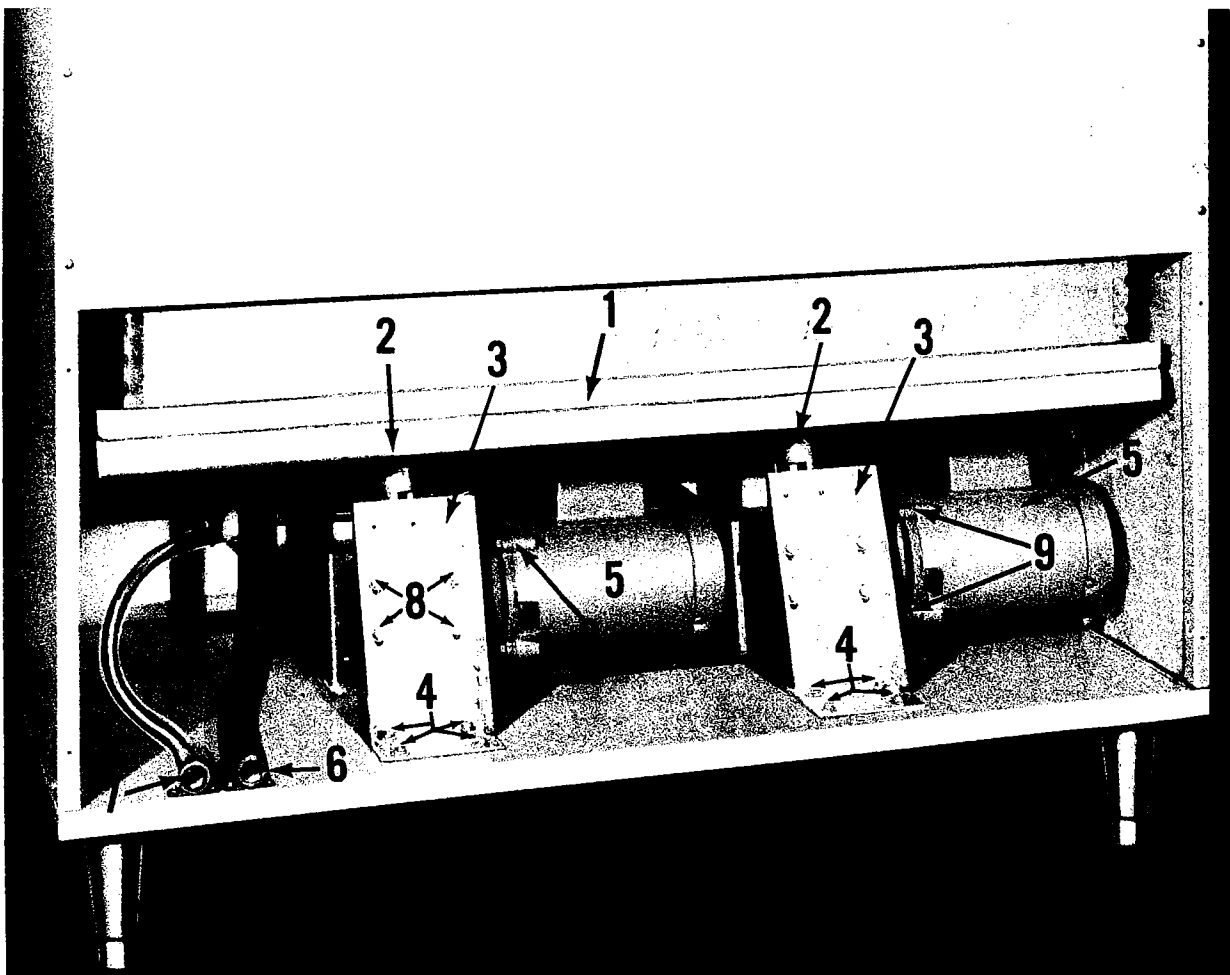

FIG. 7

1. Bin base drain pan.
2. Lower bearing & gear reducer couplings.
3. Rear gear reducer mtg. brackets.
4. Mtg. bolts mounting rear gear reducer bracket to dispenser base.
5. Gear reducer drive motors.
6. Bin drain & tubing.
7. Base drain & tubing.
8. Mtg. bolts mtg. rear gear reducer brackets to gear reducers.
9. Mtg. bolts fastening electrical drive motor to gear reducer.

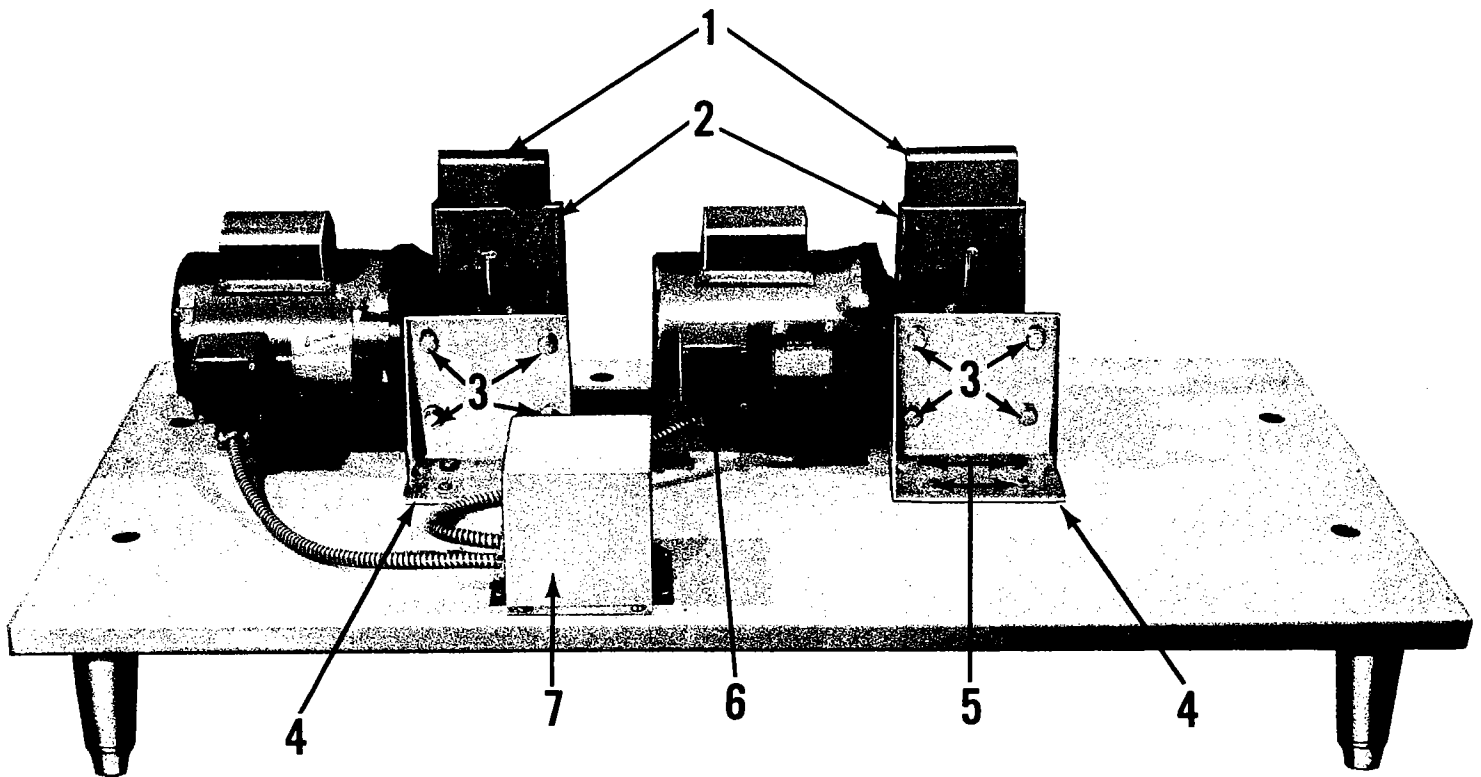

FIG. 8

1. Rear bin support bracket mounted to rear gear reducer mtg. brackets.
2. Rear gear reducer mtg. brackets.
3. Front gear reducer mtg. bolts. Mtg. brackets to gear reducers.
4. Front gear reducer brackets.
5. Mtg. bolts mtg. front gear reducer brackets to base of dispenser.
6. Gear drive motor electric function box.
7. Electrical wiring box & cover for main power supply to dispenser.

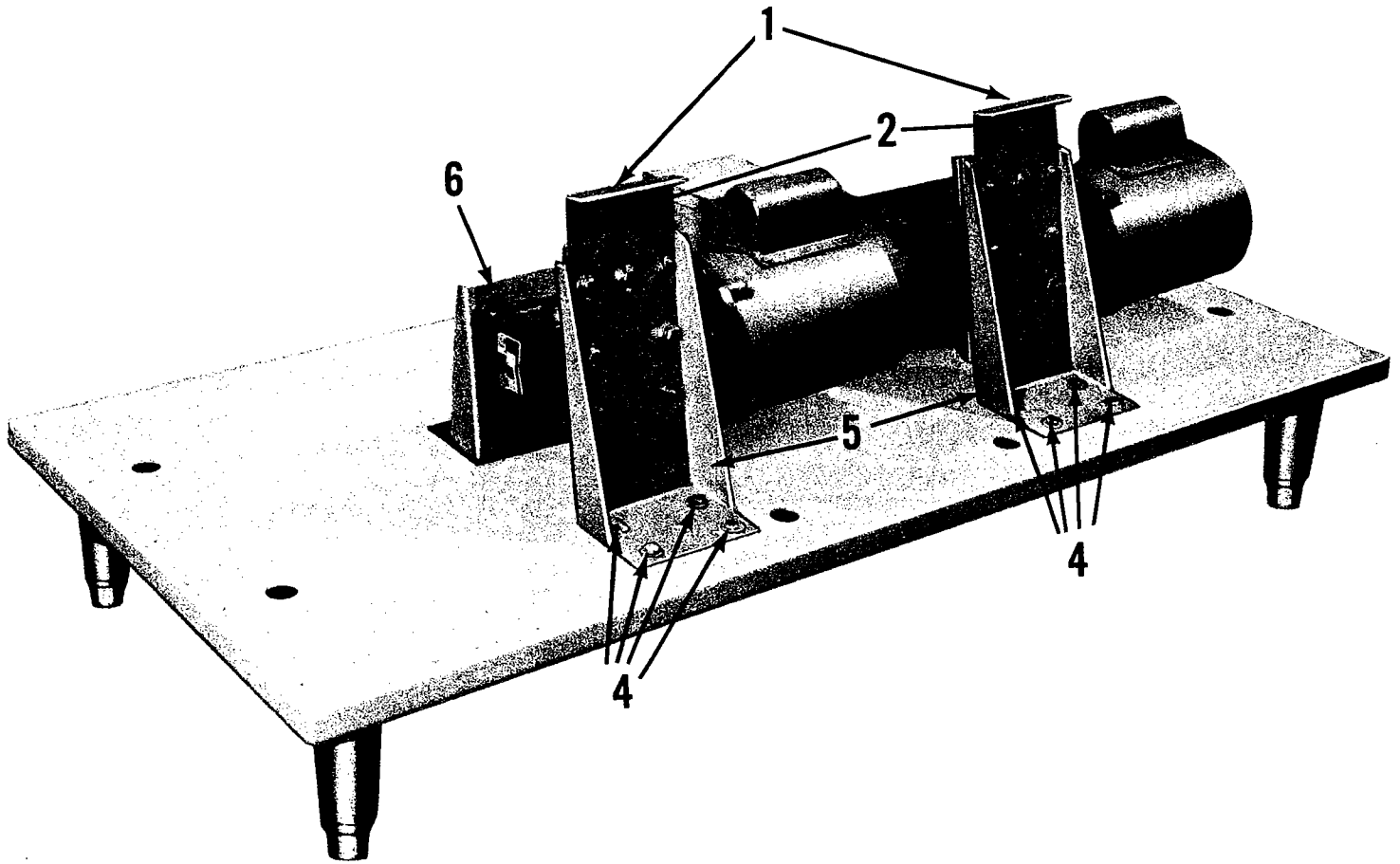

FIG. 9

1. Rear bin support brackets.
2. Rear bin support bracket mtg. bolts.
3. Mtg. bolts for mtg. rear gear reducer bracket to gear reducer.
4. Mtg. bolts for mtg. rear gear reducer bracket to dispenser base.
5. Rear gear reducer mtg. bracket.
6. Front gear reducer mtg. bracket.

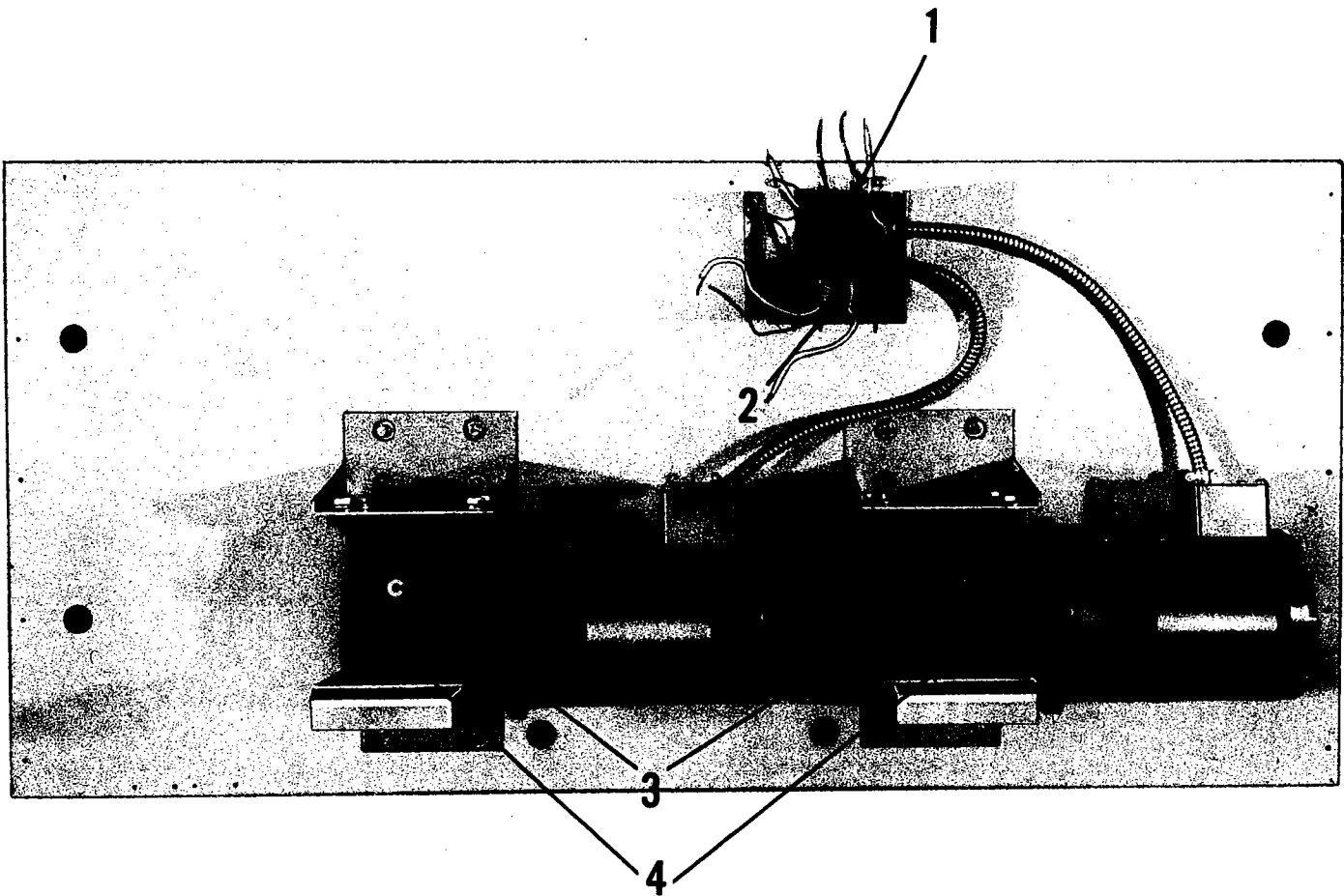

FIG. 10

1. Electrical box with cover removed.
2. Ice control switch transformer.
3. Gear reducer output shafts.
4. Gear reducer vent & fill plug.

Gear drive motor is suitable for dual voltage 115 or 230 and is shipped and wired for 230 volts. If necessary to change to 115 V see pages 31 & 32. When changing to 115 volt the transformer must be changed also by replacing the existing transformer with transformer #24-1007-9 available from our factory Parts Dept.

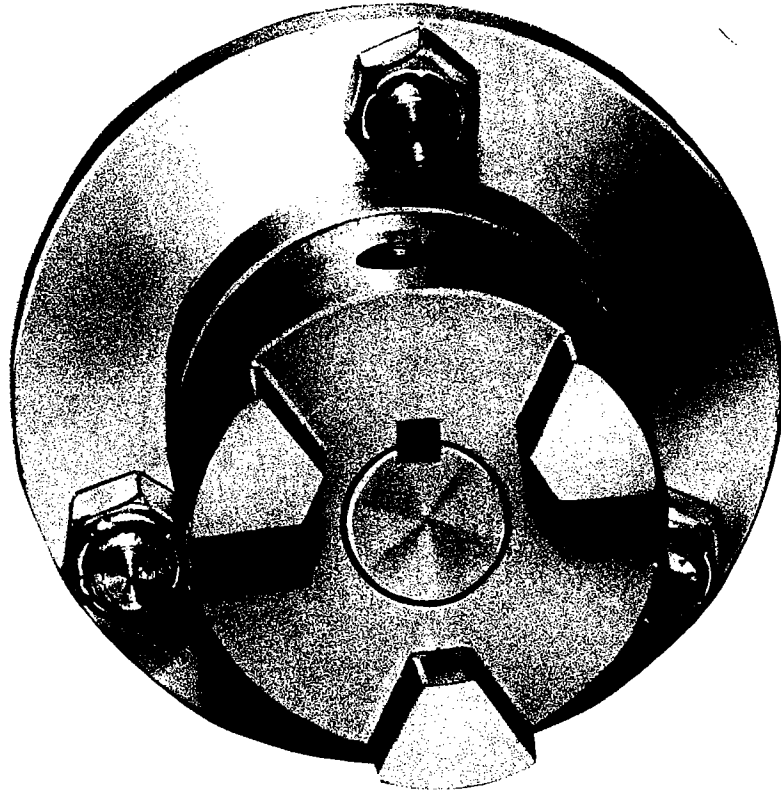
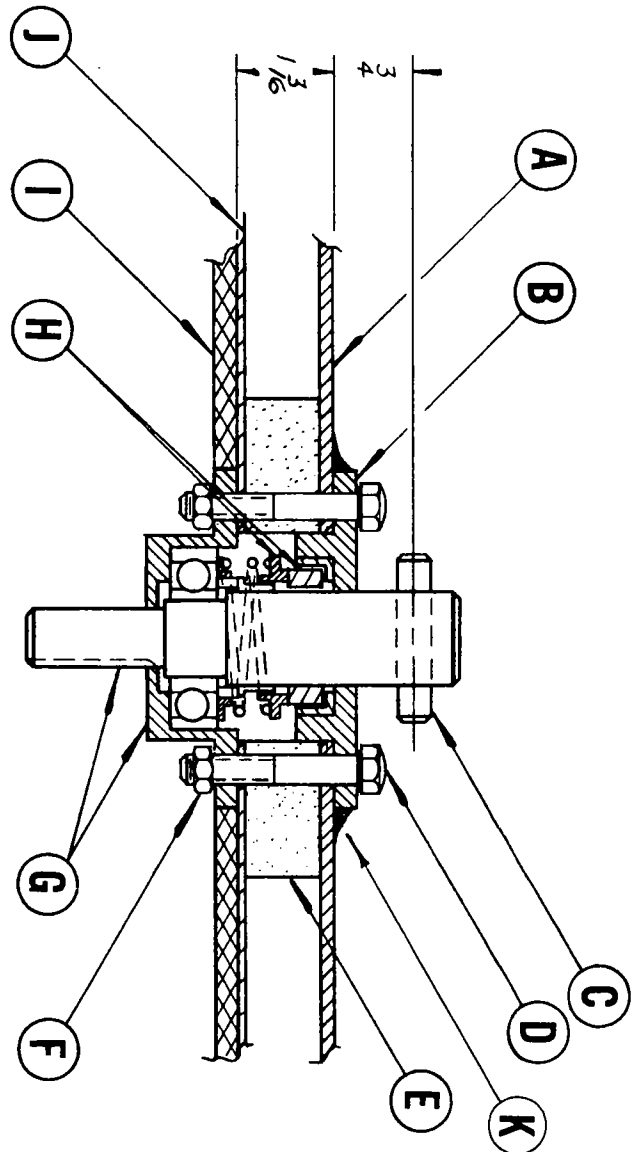
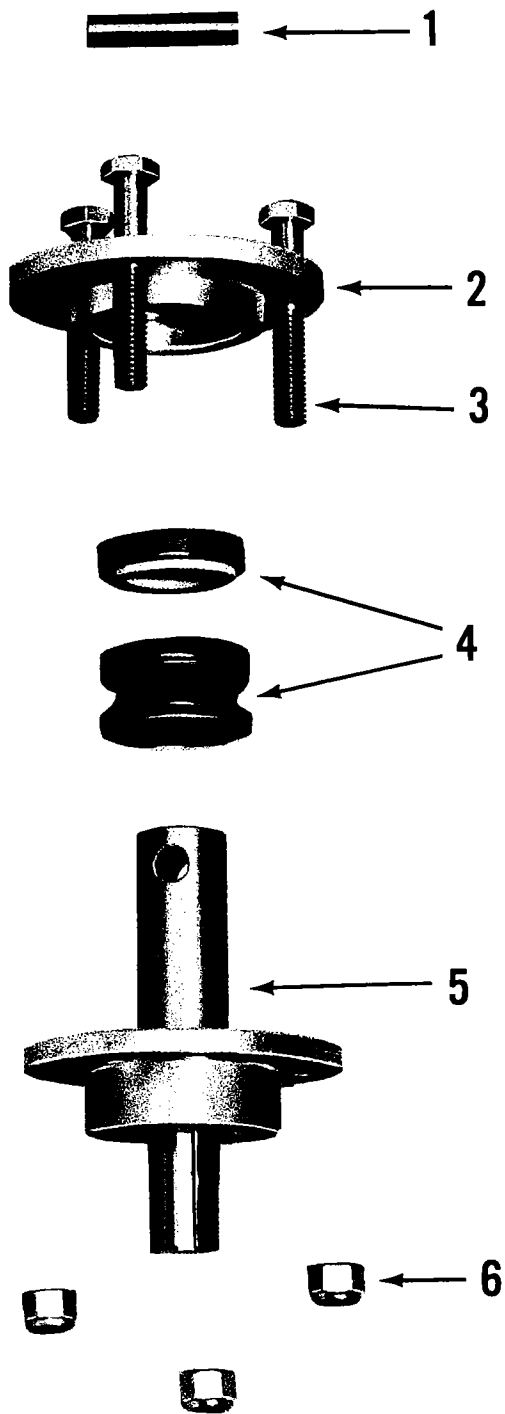

FIG. 11 LOWER BEARING ASSEMBLY WITH ONE HALF OF LOVE-JOY COUPLING.



- A. Drain pan assembly.
- B. Housing-lower seal.
- C. Pin, lower bearing shaft.
- D. Bolt 3/8-16 x 2 1/4 lg. acorn hd.
- E. Lower liner spacer.
- F. Hex lock nut 3/8-16.
- G. Lower bearing housing assembly.
- H. Lower seal — with seat
- I. Styrofoam 1/4 x 1 2 1/8 x 4 1/2 lg.
- J. Lower liner pan.
- K. R.T.V. sealer — sealing "B" to inside of BIN

FIG. 12 LOWER BEARING & SEAL ASSEMBLY.

- 1. Lower bearing shaft pin.
- 2. Lower bearing housing seal.
- 3. Lower bearing mtg. bolt.
- 4. Lower bearing housing seal and seat.
- 5. Lower bearing housing .
- 6. Lower bearing mtg. nut.

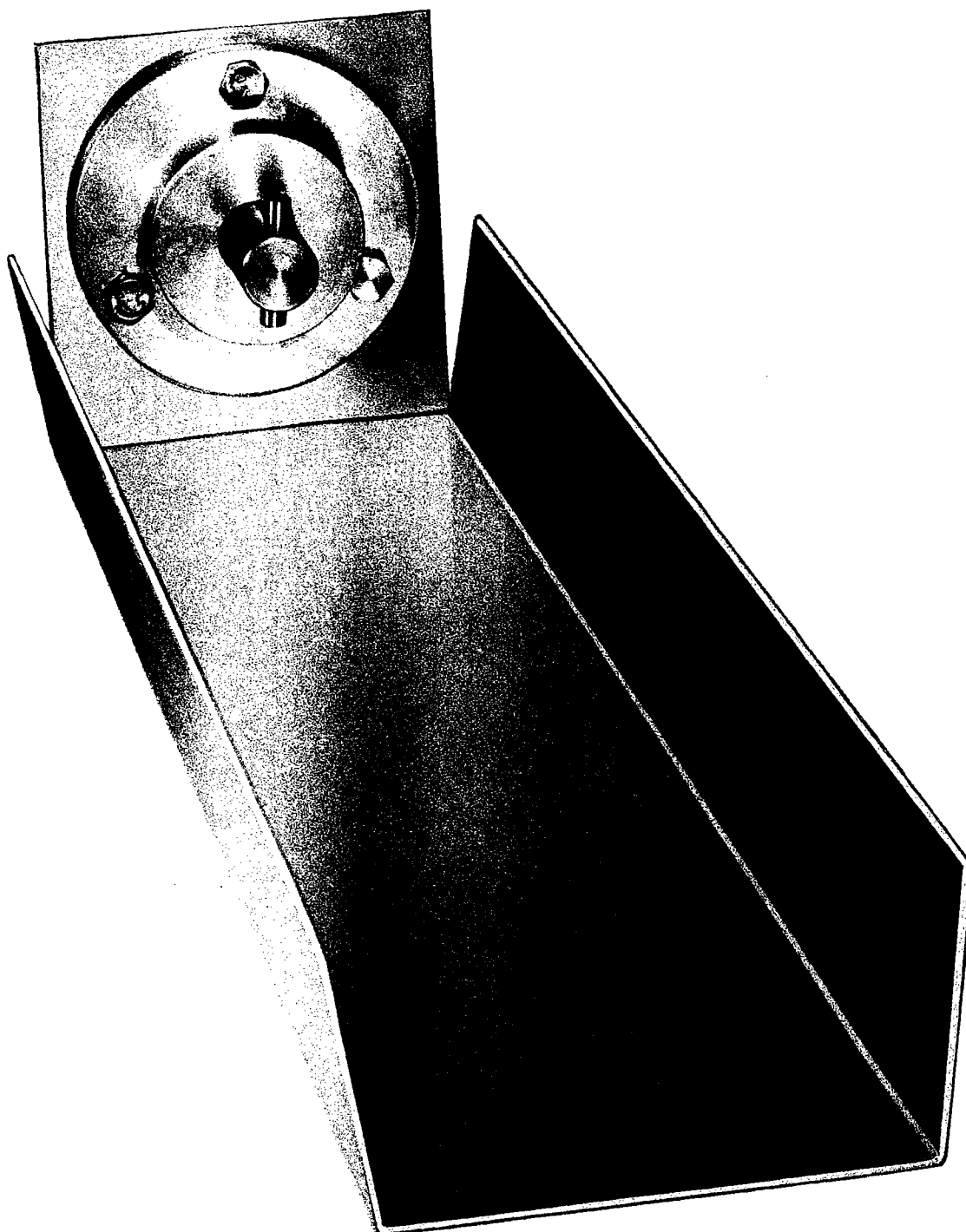

FIG. 13 AUGER ICE CHUTE & UPPER BEARING ASSEMBLY.

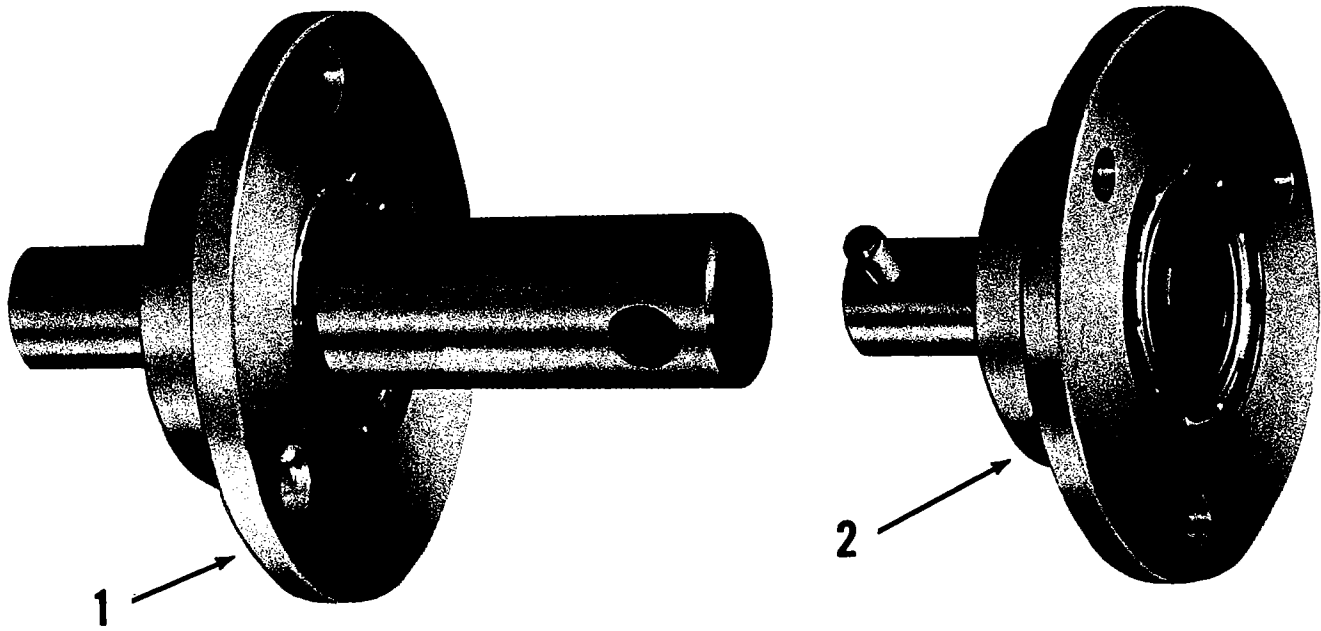

FIG. 14

- 1. Auger lower bearing assembly.
- 2. Auger upper bearing assembly.

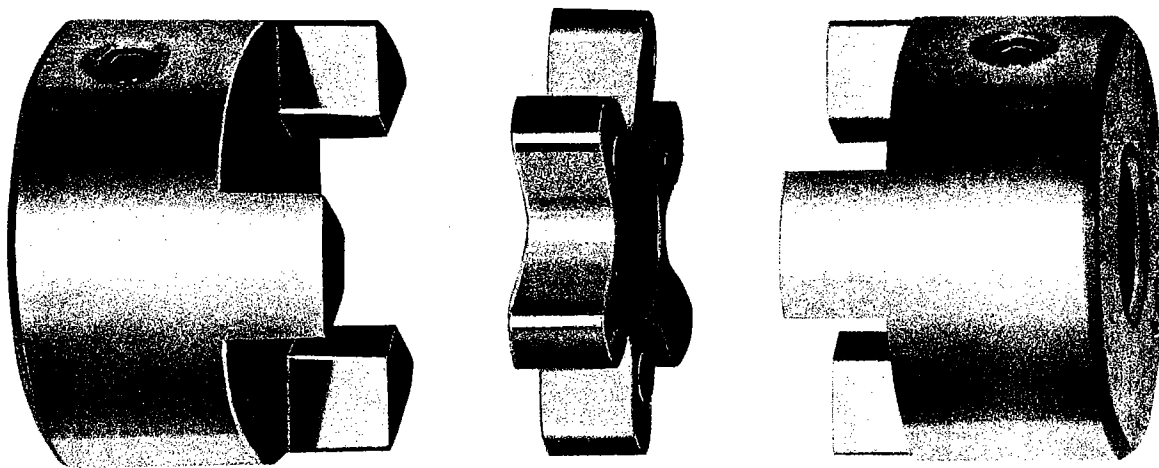

FIG. 15 LOVE-JOY COUPLING WITH SPIDER

Connecting reducer drive shaft to lower bearing drive shaft.

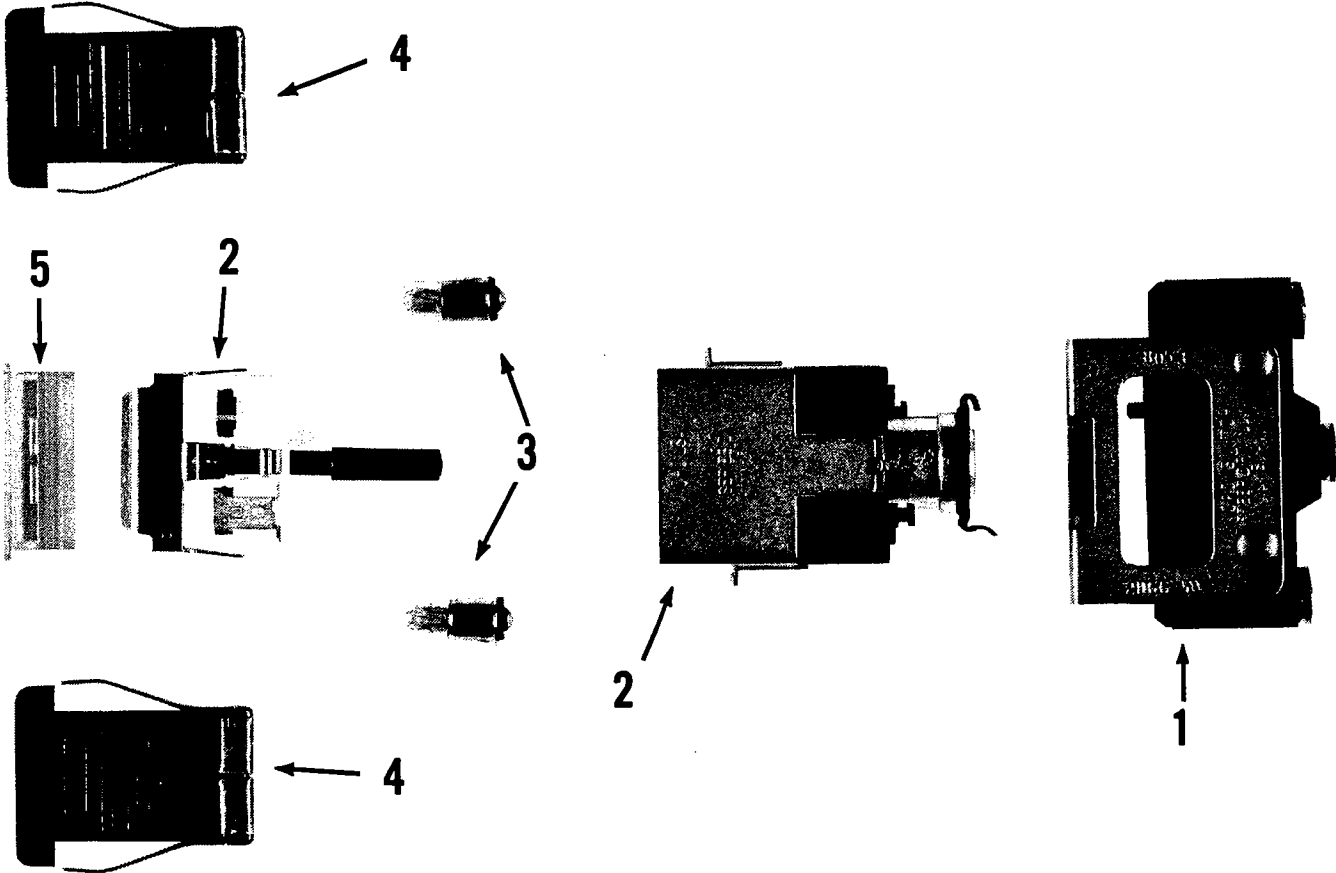

FIG. 16 ICE CONTROL SWITCH

- 1. Push button switch unit.
- 2. Push button switch housing and lamp holder.
- 3. Switch lamp.
- 4. Push button switch barrier.
- 5. Push button display screen.

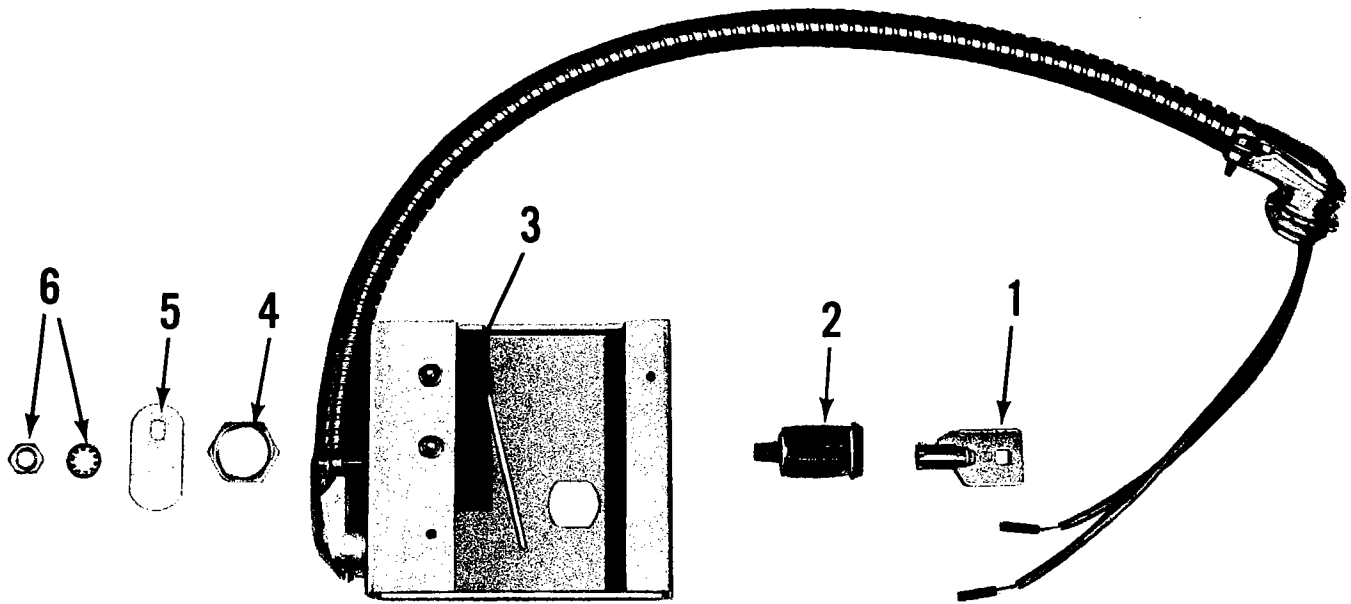
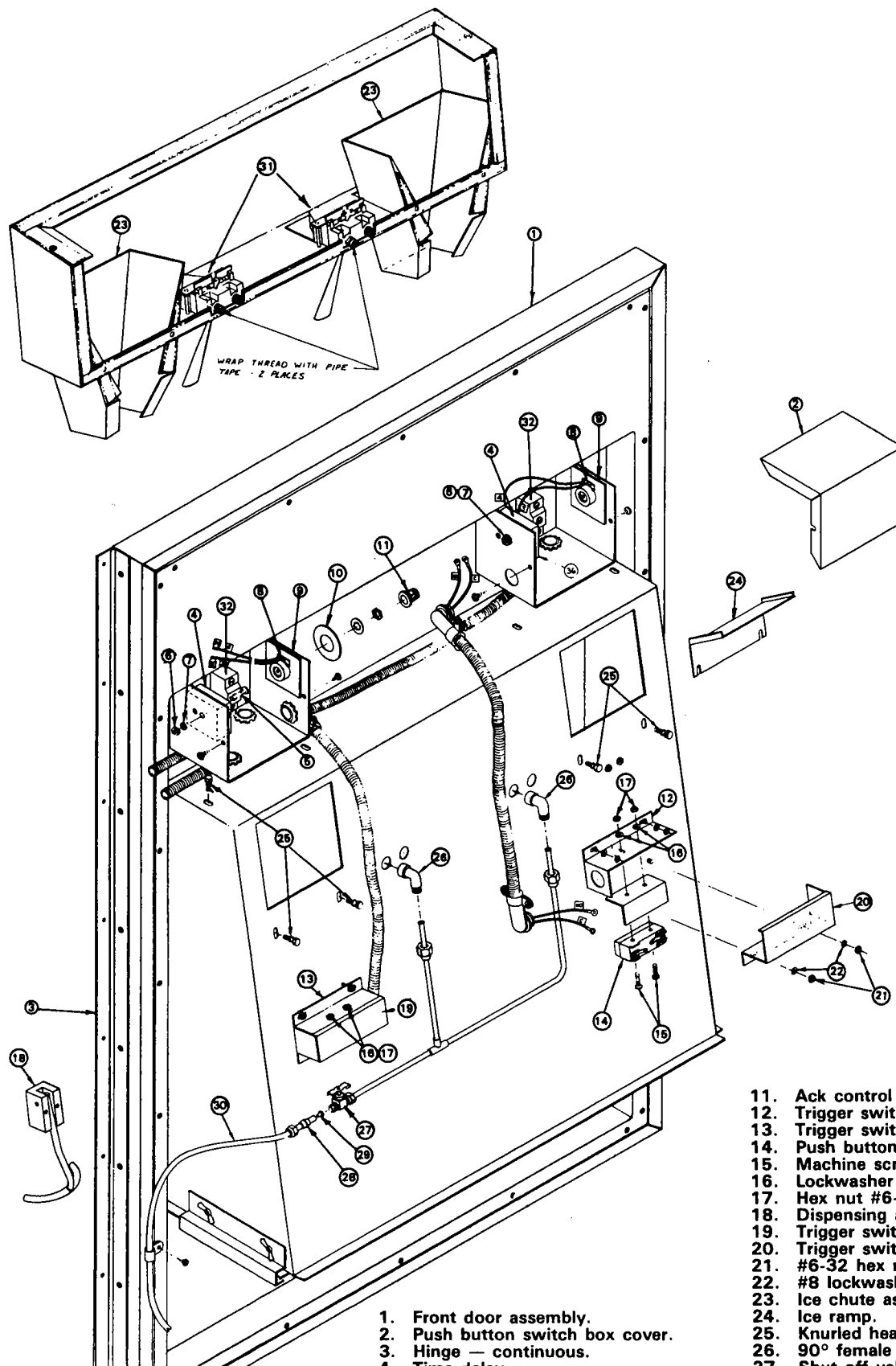

FIG. 18 KEY LOCK OUT SWITCH ASSEMBLY

- 1. Key.
- 2. Lock.
- 3. Lock out switch.
- 4. Lock retainer nut.
- 5. Lock cam.
- 6. Lock cam nut & washer.

FIG. 19 AM-0654 DOOR COMPONENTS



- |   |  |
|---|--|
| <ul style="list-style-type: none"> <li>1. Front door assembly.</li> <li>2. Push button switch box cover.</li> <li>3. Hinge — continuous.</li> <li>4. Time delay.</li> <li>5. Machine screw #6-32 x 1" lg.</li> <li>6. #6-32 brass nut.</li> <li>7. #8 lockwasher.</li> <li>8. Potentiometers.</li> <li>9. Insulation — fish paper.</li> <li>10. Label pot. time setting.</li> </ul> | <ul style="list-style-type: none"> <li>11. Ack control knob.</li> <li>12. Trigger switch bracket (L.H.).</li> <li>13. Trigger switch bracket (R.H.).</li> <li>14. Push button micro switch.</li> <li>15. Machine screw #6-32 x 7/8" lg.</li> <li>16. Lockwasher #8.</li> <li>17. Hex nut #6-32 brass.</li> <li>18. Dispensing arm assembly.</li> <li>19. Trigger switch bracket cover (R.H.).</li> <li>20. Trigger switch bracket cover (L.H.).</li> <li>21. #6-32 hex nut brass.</li> <li>22. #8 lockwasher.</li> <li>23. Ice chute assembly.</li> <li>24. Ice ramp.</li> <li>25. Knurled head machine screws.</li> <li>26. 90° female elbow.</li> <li>27. Shut off valve w/2 comp. nuts.</li> <li>28. 1/4 brass sleeves.</li> <li>29. Nylon insert.</li> <li>30. Nylon tube 45" lg.</li> </ul> |
|---|--|
21. #6-32 hex nut brass.  
 22. #8 lockwasher.  
 23. Ice chute assembly.  
 24. Ice ramp.  
 25. Knurled head machine screws.  
 26. 90° female elbow.  
 27. Shut off valve w/2 comp. nuts.  
 28. 1/4 brass sleeves.  
 29. Nylon insert.  
 30. Nylon tube 45" lg.

Push button micro switch  
 (See page 23).

# MODEL AM-0661 & 662 JUNCTION BOX HOOK-UP

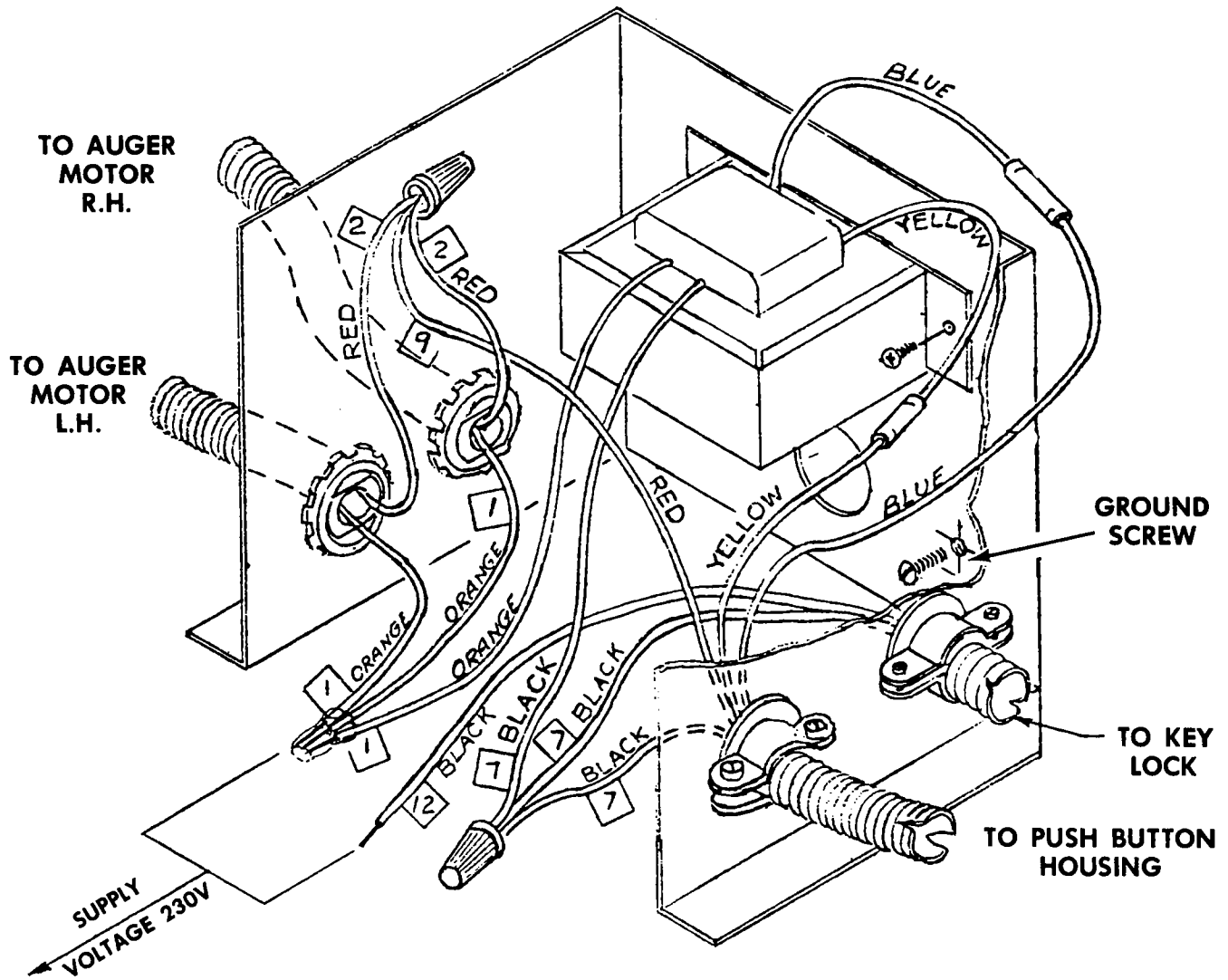

**AM-0661 DISPENSER**  
**PUSH BUTTON ICE ONLY 230V., 60 HZ./50 HZ.**

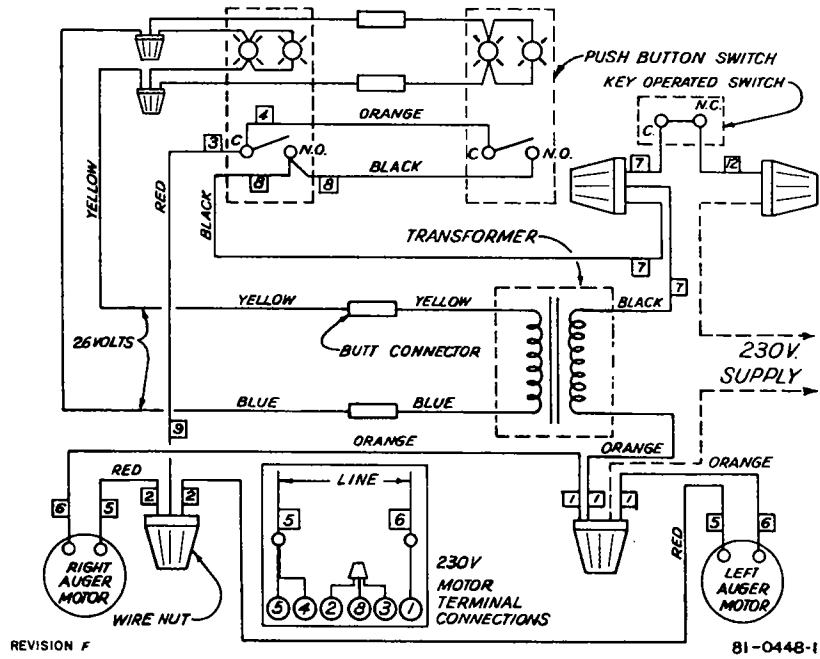

**AM-0662 DISPENSER**  
**KEY ICE ONLY, 230V., 60HZ./50HZ.**

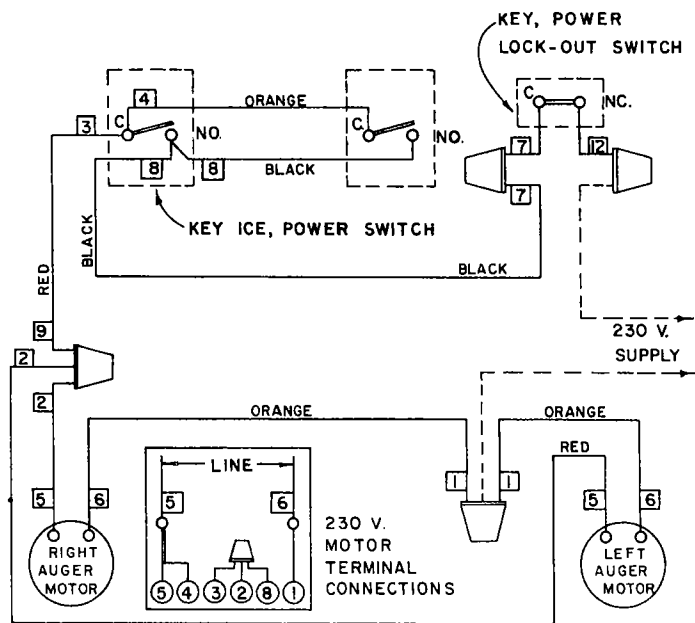

# MODEL AM-0651 & 652 JUNCTION BOX HOOK-UP

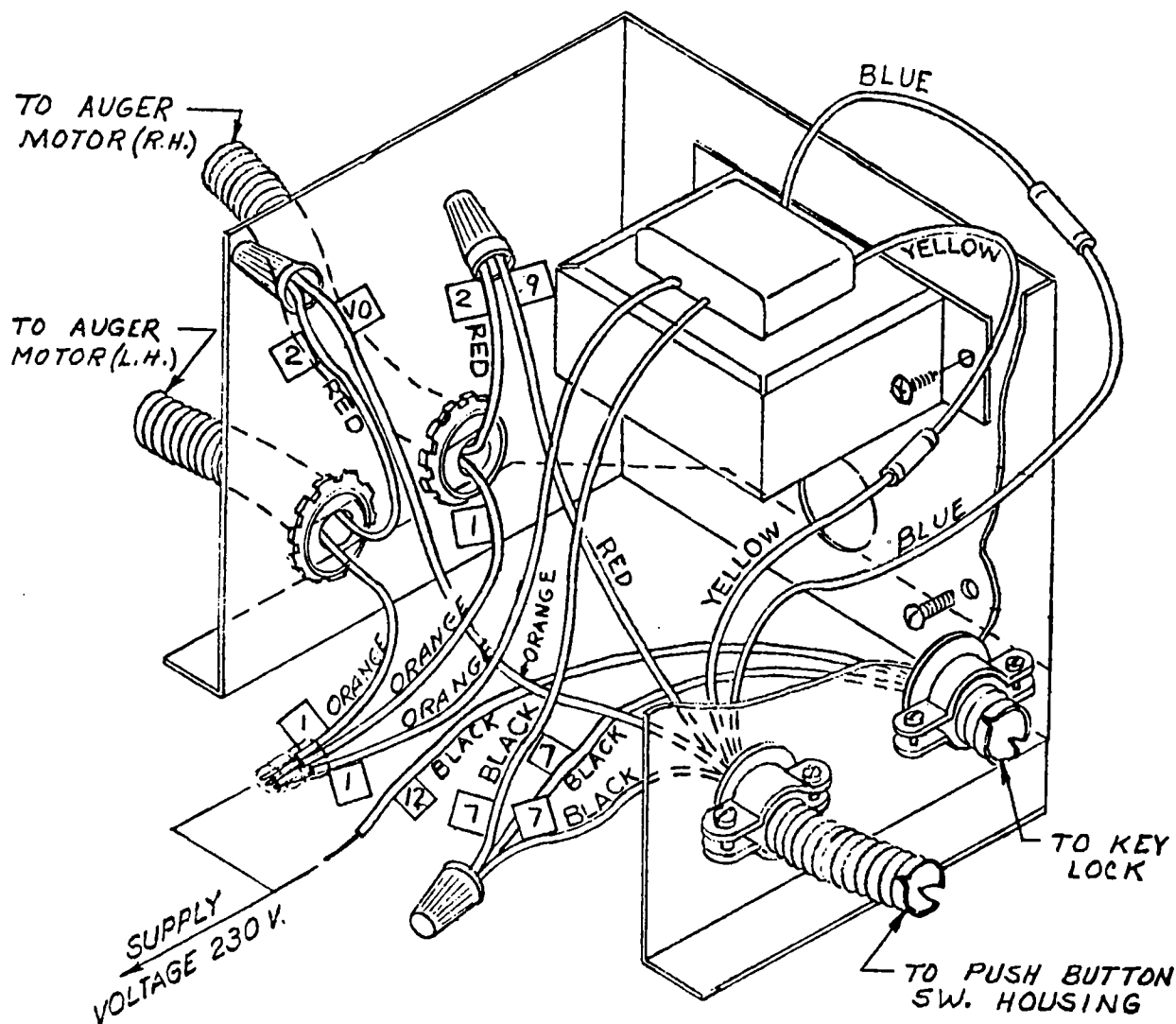

**AM-0651 DISPENSER  
PUSH BUTTON ICE ONLY 230V., 60HZ./50HZ.**

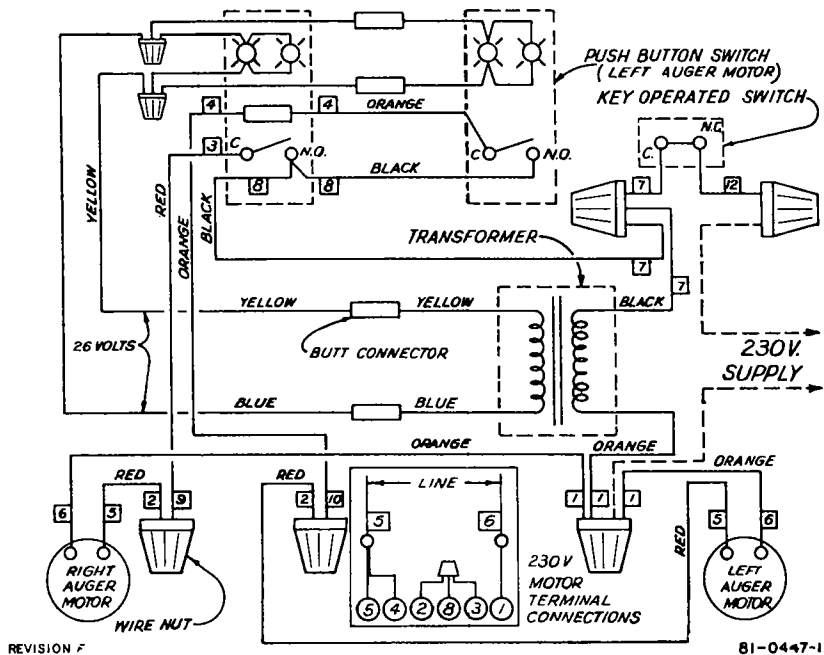

**AM-0652 DISPENSER  
KEY ICE ONLY, 230V., 60HZ./50HZ.**

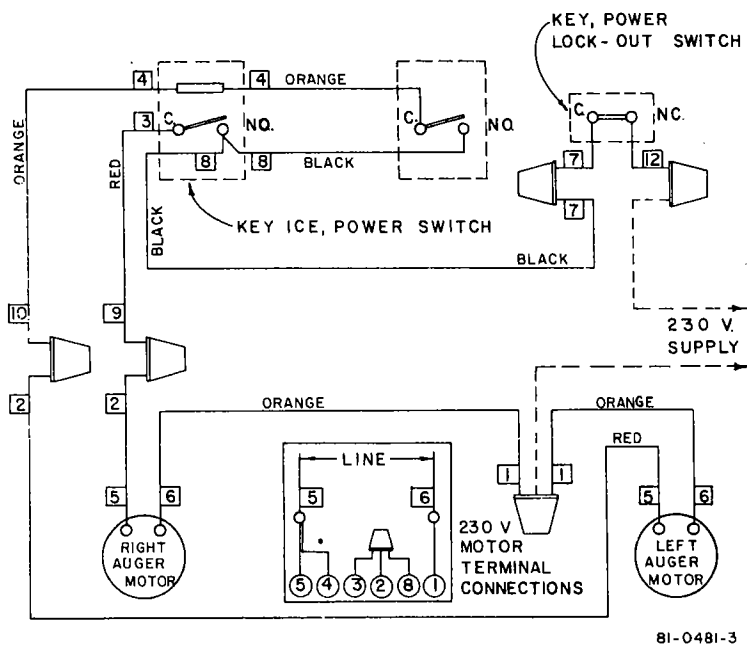

**AM-0654 DISPENSER**

**Push Button Ice, Trigger Ice, Trigger Water  
208/230V., 50/60HZ., SINGLE PHASE, PORTION CONTROL**

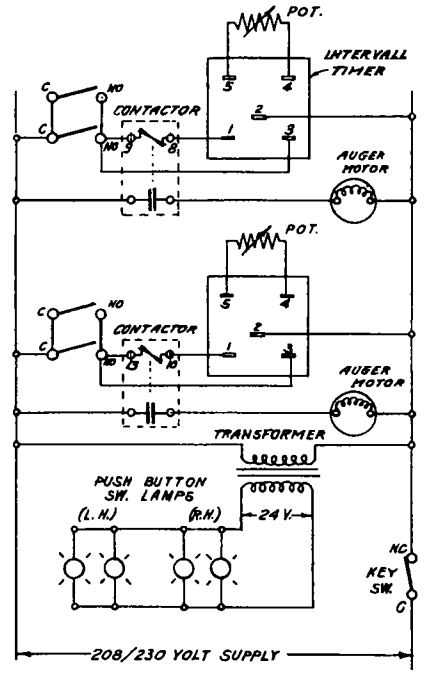
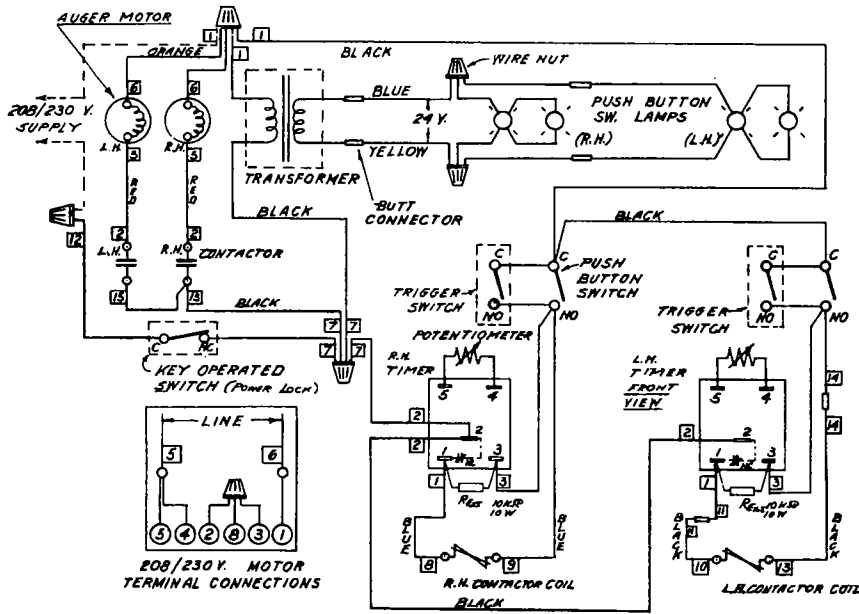

REVISION 81-0503-3

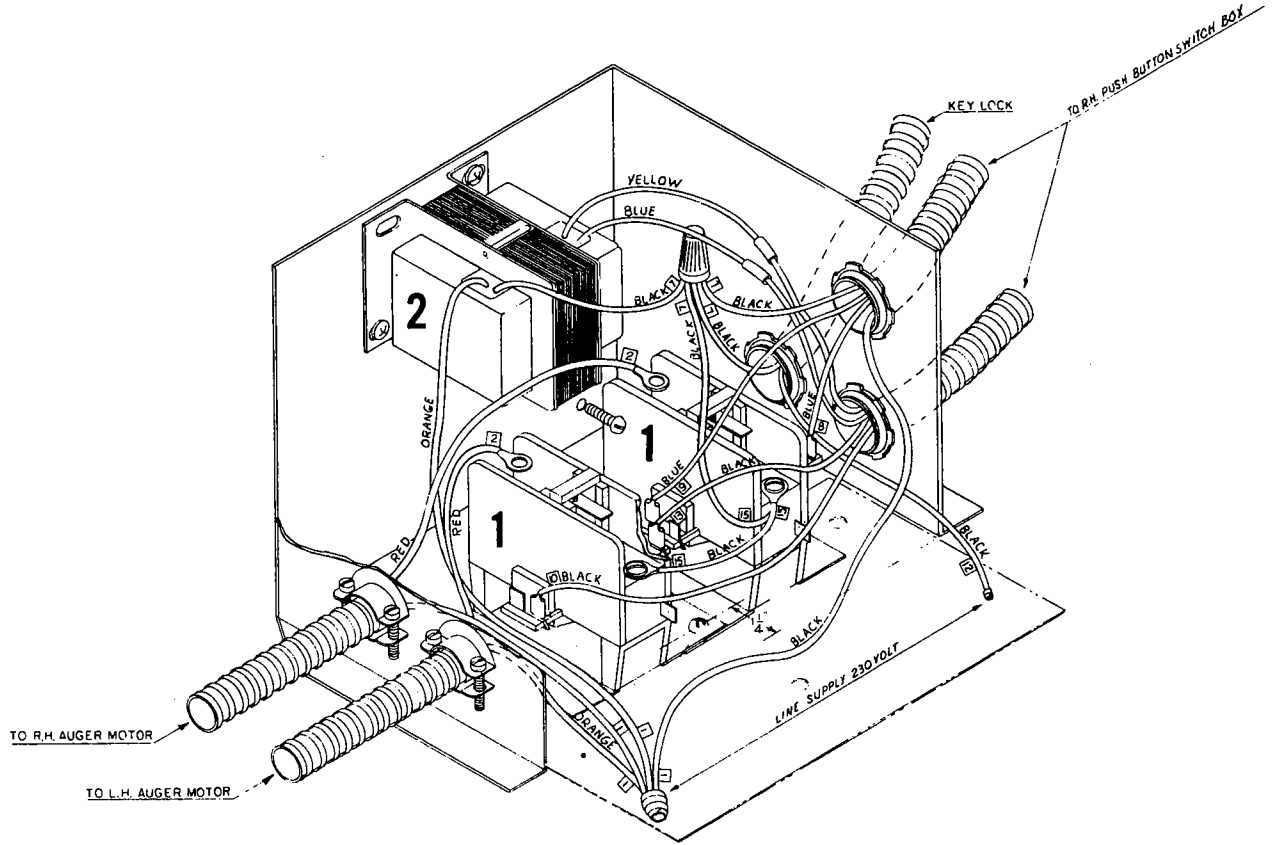

**MODEL AM-0654  
JUNCTION BOX HOOK-UP**

1. Single pole contactors (2).
2. Transformer.

## SERVICE ANALYSIS

COMPLAINT	CAUSE	CORRECTIVE MEASURE
Will not dispense ice	Power off	Check fuse & wiring
	Defective ice control switch	Check & replace, if necessary
	Drive motor defective	Check & replace, if necessary
	Set screws on drive coupling loose	Check & tighten
	Bin empty	Check ice cuber for proper ice production
	Large clusters of ice in bin	Check ice bridging & adjust
Drive motor operates but auger does not turn	Ice jammed in ice chute opening	Check & clear opening
	Defective gear reducer	Check & replace
	Set screw on drive coupling loose	Check & tighten
	Auger not properly seated on lower bearing drive shaft	Check & replace on lower bearing drive shaft

## CLEANING INSTRUCTIONS

In place cleaning.

1. Auger out ice from storage bin. Note: Not all ice can be augered out; there will always be some ice remaining in bottom of bin.
2. Remove auger access door from bin liner by removing the 18 thumb screws (See Fig. 4). Remove balance of ice from bottom of storage bin.
3. Remove augers as shown in Fig. 5 on instructions under REMOVING AUGER ASSY. Page 6.
4. Scrub inside of bin and augers using a nylon scouring pad, brushes and a cleaning solution, such as Lime-a-Way or Boss Brand Milk Stone Cleaner from Northern Laboratories. Rinse all parts with clear water.
5. Inside of bin and parts can be sanitized by rinsing with a solution of one teaspoon of Sodium Hypochlorite in one gallon of water.
6. Reassemble unit. Let run for 5 to 6 hours before dispensing ice.
7. For cleaning ice cuber refer to cleaning instructions in Service Manual found inside instruction envelope received with ice cuber.
8. Remove ice cube melting tray located beneath wire grill. Both are located in stainless steel front door. Unlock door, swing open and pull melting tray out (See Fig. 3). This can be cleaned with same cleaning solution as used for inside of storage bin. Rinse with clear water and replace.

## **SERVICE AND PARTS PROCEDURES**

### **Ordering Procedure**

Replacement parts for Manitowoc ice machine equipment should be ordered directly from your local Manitowoc Ice Machine distributor. Parts are stocked by the distributor in order to provide prompt and efficient service for ice machines sold in their areas.

Should you encounter difficulty in locating a Manitowoc distributor in your area, contact Manitowoc Service Parts Dept. for the name or names of distributors in your area.

Parts ordered will be billed according to our price list schedule.

Transportation companies are responsible for damage in transit as all shipments are tendered to them in good condition; and our responsibility ceases upon receipt of a signed bill of lading from the carrier. If the shipment arrives in a damaged condition or is short, the delivery carrier should be notified immediately.

### **Return of Defective Parts**

All warranty parts must be returned to the company from whom the replacement part or parts were purchased. Parts must be returned, transportation prepaid, must be properly packaged to prevent further damage and tagged with a return material tag properly filled in. It is especially important that the cabinet serial number be secured and recorded on the tag, securing as much information as possible about the nature of the defect to prevent any delays in issuing credit. All parts should be returned as they are removed from the cabinet and not mutilated or tampered with. The return material tags are provided on a no-charge basis by the factory upon receipt of your request. Upon receipt of these parts here at the factory, they will be inspected; and if they are found to be defective, in material and workmanship, under normal use and service, credit will be issued. Any part not properly packaged will be returned to the sender freight collect and no credit will be issued.

Our warranty and protection plan does not apply to cabinets that are not registered; therefore, it is necessary that, upon completion of the installation of the cabinet, the registration card be signed on the date of installation and mailed promptly to the factory Service Department in order for the cuber to be registered.

### **Return of Hermetically-sealed Units**

Extreme care should be used in servicing the hermetically-sealed mechanism. It is important that the trouble be correctly determined before the unit is changed. Be sure it is not the control, relay or overload causing the trouble. The defect must be listed on the return material tag. Hermetically-sealed units must be returned with service valves closed and capped. All lines must be pinched and soldered shut.

### **Return of Complete Machines**

Complete machines may not be shipped back to the factory for repairs without first securing prior permission from the factory. If an unauthorized missing shipment is received at the factory it will be refused by our warehouse and immediately returned to the sender. Upon receipt of your request to return a cabinet, if we feel that your request is legitimate, you will be sent an authorized label authorizing you to return this cabinet to the factory freight prepaid.

When returning water cooled models, make sure all water lines are blown out before returning ice cuber to prevent lines from freezing during cold weather.

# Ice Machine and Bin Warranty

From the date of original installation, we do hereby warrant each new Ice Machine and Bin to be free from defects in material and workmanship, under normal use and service, for a period of one year, and four additional years on the hermetic motor compressor in the Ice Machine.

Our obligation under this warranty is limited solely to correcting or replacing without charge at the factory in Manitowoc, Wisconsin any part or parts of this equipment which shall have been returned, transportation prepaid, and which our examination discloses to our satisfaction to be defective.

This warranty does not apply to any equipment that has been damaged by flood, fire, or suffered abuse, misuse, neglect or accident, or to any Ice Machine which has been altered so as to affect performance or reliability, except where such alteration has been accomplished with our prior written consent.

We further limit this warranty in that we shall not be held liable under this contract for any special, indirect, or consequential damages whatsoever resulting from any defect in material and workmanship which interferes with the normal use and service of such Ice Machine and Bin.

This warranty is a complete and exclusive statement of all terms of the agreement between the Manitowoc Equipment Works and the owner of the equipment, and all representations of the parties. This agreement shall not be varied, supplemented, qualified or interpreted by any prior course of dealing between the parties or by any usage of the trade.

Sales are made on the express understanding that there are no express or implied warranties other than the express warranty herein contained and that there are no implied warranties that the goods shall be merchantable or fit for a particular purpose other than the expressed one year and five year warranty set forth above.

To validate this warranty, the registration card must be signed on the date of installation and mailed promptly to the Manitowoc Equipment Works, Manitowoc, Wisconsin.

DEALER \_\_\_\_\_  
\_\_\_\_\_  
\_\_\_\_\_

INSTALLATION DATE \_\_\_\_\_

**MANITOWOC EQUIPMENT WORKS**  
(A division of The Manitowoc Co., Inc.)  
2110 South 26th St., Ph: 414-682-0161  
Manitowoc, Wisconsin 54220