

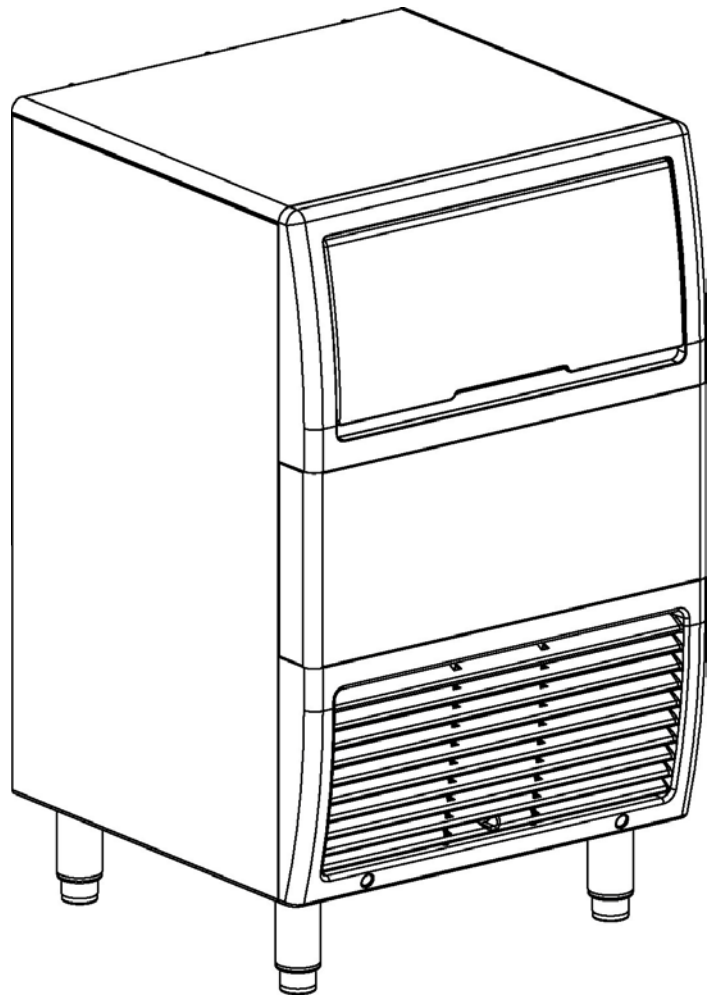

Installation Use and Care

EC Series Ice Machines



This manual is updated as new information and models are released. Visit our website for the latest manual.
www.manitowocice.com

Table of Contents

Table of Contents

Section 1 - Installation Instructions

MODEL/SERIAL NUMBER LOCATION	1-1
LOCATION OF ICE MACHINE	1-2
LEVELING THE ICE MACHINE.....	1-2
ELECTRICAL SERVICE.....	1-3
WATER SERVICE/DRAINS.....	1-4
ICE MACHINE DIMENSIONS	1-5
INSTALLATION CHECKLIST.....	1-6

Section 2 – Component identification

EVAPORATOR COMPONENTS	2-1
CONDENSER, CONTROLS, AND AIR FILTER.....	2-2

Section 3 – Ice Making Sequence Of Operation

ICE MAKING SEQUENCE OF OPERATION.....	3-1
OPERATIONAL CHECKS	3-2

Section 4 – Maintenance

MAINTENANCE CHART.....	4-1
CLEANING CONDENSER	4-2
CLEANING PROCEDURE.....	4-3
SANITIZING PROCEDURE.....	4-4
REMOVAL FOR WINTERIZATION	4-5
BEFORE CALLING FOR SERVICE	4-6

General Information

It is recommended that this ice machine be inspected and installed by a qualified service technician.

Follow all recommendations and instructions for proper installation and safe operation of this ice machine.

⚠ WARNING

If you do not understand the procedures or the safety precautions that must be followed, call your local service representative to perform the necessary installation procedures for you.

⚠ WARNING

PERSONAL INJURY POTENTIAL

Do not operate equipment that has been misused, abused, neglected, damaged, or altered/modified from that of original manufactured specifications.

Model Numbers

This manual covers the following models:

Self-Contained Air-Cooled	Self-Contained Water-Cooled
ECS018A	Not Available
ECG018A	Not Available
ECS023A	ECS023W
ECG023A	ECG023W
ECS031A	ECS031W
ECG031A	ECG031W
ECS041A	ECS041W
ECG041A	ECG041W
ECS051A	ECS051W
ECG051A	ECG051W
ECS065A	ECS065W
ECG065A	ECG065W
ECS080A	ECS080W
ECG080A	ECG080W

Model Numbers Identification

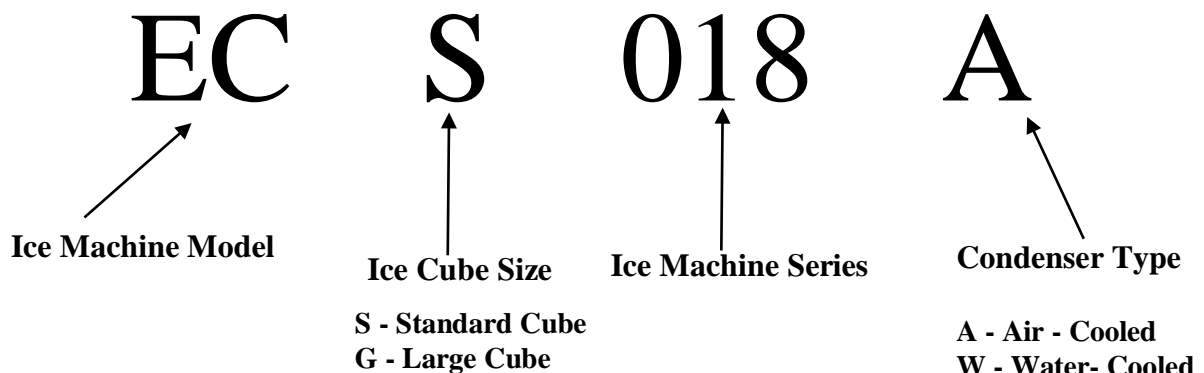

Location of Ice Machine

The location selected for the ice machine must meet the following criteria. If any of these criteria are not met, select another location.

- The location must be indoors.
- The location must be free of airborne and other contaminants.
- The air temperature must be at least 10°C (50°F), but must not exceed 43°C (110°F).
- The location must not be near heat-generating equipment or in direct sunlight.
- The location must be capable of supporting the weight of the ice machine and a full bin of ice.
- The location must allow enough clearance for water, drain and electrical connections in the **rear of the ice machine**.
- The location must not obstruct airflow through or around the ice machine (condenser airflow is in and out the front). Refer to the chart below for clearance recommendations.

	Self-Contained Air-Cooled	Self-Contained Water-Cooled
Top/Sides	203 mm (8 in.)*	127 mm (5 in.)*
Back	127 mm (5 in.)*	127 mm (5 in.)*

* NOTE: The ice machine may be built into a cabinet. There is no minimum clearance requirement for the top or left and right sides of the ice machine. The listed values are recommended for efficient operation and servicing only.

CAUTION

The ice machine must be protected if it will be subjected to temperatures below 0°C (32°F). Failure caused by exposure to freezing temperatures is not covered by the warranty.

Leveling the Ice Machine

Levelers are included with all ice machine. Legs are an available option.

1. Screw the legs or levelers into the bottom of the ice machine.

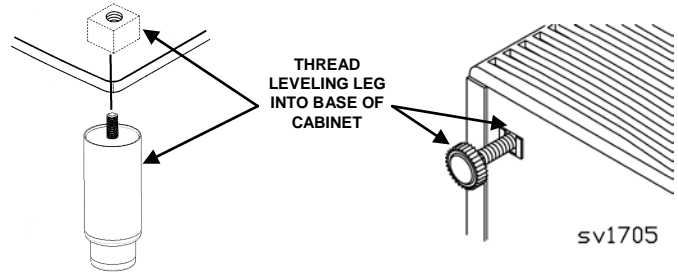

2. Screw the foot of each leg or leveler in as far as possible. Move the ice machine into its final position.
3. Level the ice machine correctly. Use a level on top of the ice machine. Turn each foot as necessary to level the ice machine from front to back and side to side.

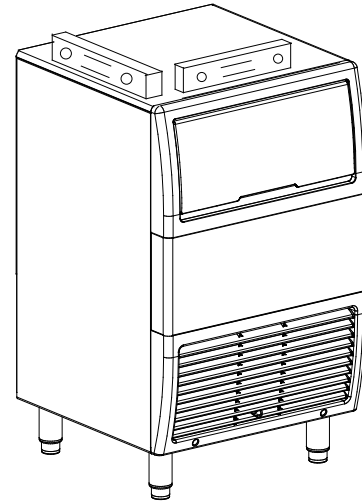

Checking Ice Machine Level

Electrical Service

GENERAL



WARNING

All wiring and ground connections must conform to local, state and national codes.

VOLTAGE

The maximum allowable voltage variation is $\pm 6\%$ of the rated voltage on the ice machine model/serial number plate at start-up (when the electrical load is highest).

All ice machines are factory pre-wired with a 2 meter (6 ft) power cord, no plug is supplied.

FUSE/CIRCUIT BREAKER

A separate fuse/circuit breaker must be provided for each ice machine. An electrical disconnect switch must be provided if the ice machine is hard wired (wired without a plug).

TOTAL CIRCUIT AMPACITY

The total circuit ampacity is used to help select the wire size of the electrical supply.

The wire size (or gauge) is also dependent upon location, materials used, length of run, etc., This must be determined by a qualified electrician.



WARNING

Risk Of Electrical Shock

This ice machine must be properly grounded and connected to the field wiring terminal in accordance with all applicable national and local electrical codes by a qualified electrician. Before connecting wires, disconnect power at the electrical disconnect and lock out to prevent accidentally energizing. Connect all electrical wiring before use - do not energize ice machine until installation is complete..

1. Connect –the three supply lead wires (Blue, Brown, and Yellow/Green) to the field wiring terminal, “L”, “N”, and “G”, the Yellow/Green wire must connect to the “G”(ground).
2. After connecting the wiring to the terminal strip, the supply lead must be secured to the cabinet with a strain relief near the terminal strip.
3. Verify wiring is contained in the electrical wiring box.

Ice Machine	Voltage Phase Cycle	Air-Cooled		Water Cooled	
		Maximum Fuse/Circuit Breaker	Total Amps	Maximum Fuse/Circuit Breaker	Total Amps
EC018	230/1/50	10 Amp	2.2	N/A	N/A
	230/1/60	10 Amp	2.2	N/A	N/A
EC020	230/1/50	10 Amp	2.5	10 Amp	2.3
	230/1/60	10 Amp	2.5	10 Amp	2.3
EC030	230/1/50	10 Amp	3.4	10 Amp	3.2
	230/1/60	10 Amp	3.4	10 Amp	3.2
EC040	230/1/50	10 Amp	3.4	10 Amp	3.1
	230/1/60	10 Amp	3.4	10 Amp	3.1
EC050	230/1/50	10 Amp	4.0	10 Amp	3.7
	230/1/60	10 Amp	4.0	10 Amp	3.7
EC065	230/1/50	10 Amp	4.2	10 Amp	3.8
	230/1/60	10 Amp	4.2	10 Amp	3.8
EC080	230/1/50	10 Amp	4.4	10 Amp	4.0
	230/1/60	10 Amp	4.4	10 Amp	4.0

Water Service/Drains

WATER SUPPLY

Local water conditions may require treatment of the water to inhibit scale formation, filter sediment, remove chlorine, and improve taste and clarity.

WATER INLET LINES

Follow these guidelines to install water inlet lines:

- Do not connect the ice machine to a hot water supply. Be sure all hot water restrictors installed for other equipment are working. (Check valves on sink faucets, dishwashers, etc.)
- Water pressure to the machine should be between 1.4 to 5.5 bar (20 to 80 psi).
- If water pressure exceeds the maximum 5 bar recommended pressure, obtain a water pressure regulator from your Manitowoc distributor. Adjust pressure to 2.5 bar (37 psi).
- Install a water shut-off valve.
- Connect to a potable water supply only.

Important

If you are installing a water filter system, make sure that you use a separate line for water-cooled condenser. Filter life will be greatly reduced if filtered water is used for water-cooled condenser.

DRAIN CONNECTIONS

Follow these guidelines when installing drain lines to prevent drain water from flowing back into the ice machine and storage bin:

- Drain lines must have a 3.8 cm (1.5 inch) drop of run for each meter (3 feet), and must not create traps.
- The floor drain must be large enough to accommodate drainage from all drains.
- Run separate bin and water-cooled condenser drain lines. Insulate them to prevent condensation.

WATER SUPPLY AND DRAIN LINE SIZING/CONNECTIONS

	Water Temperature	Water Pressure	Ice Machine Fitting	Tubing Size Up to Ice Machine Fitting
*Ice Making Water Inlet	10°C (50°F) Min. 32°C (90°F) Max.	140 kPa (20 Psi) Min. 550 kPa (80 Psi) Max	3/4" Male Pipe Thread	15mm (1/2") Inside Diameter Minimum
**Drain Connection Outlet	-----	-----	7/8" Barb connection	18mm (3/4") Minimum Inside Diameter
Condenser Water Inlet	0.6°C (33°F) Min. 32.2°C (90°F) Max.	140 kPa (20 Psi) Min. 1030 kPa (150 Psi) Max	3/8" Female pipe Thread	15mm (1/2") Inside Diameter Minimum
Condenser Water Outlet	-----	-----	1/2" Female pipe Thread	15mm (1/2") Minimum Inside Diameter

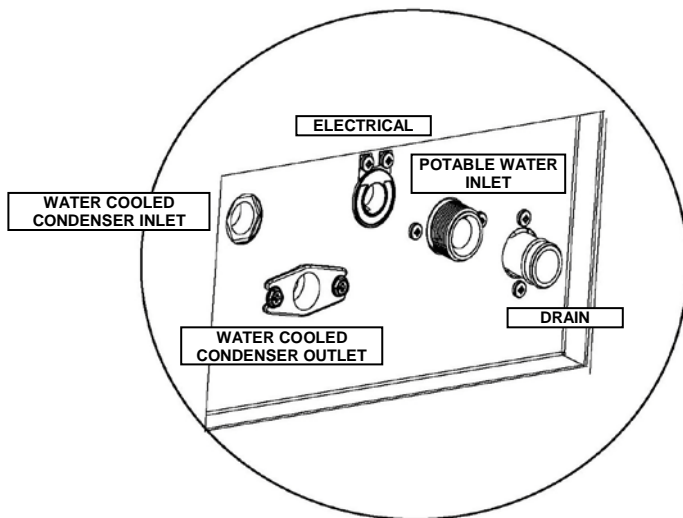

* Water inlet hose supplied with machine.
3/4" Female Pipe Thread/ 2 meters long.

** Drain hose supplied with machine.
7/8" (22.2mm) hose/ 2 meters long.

Dimensions

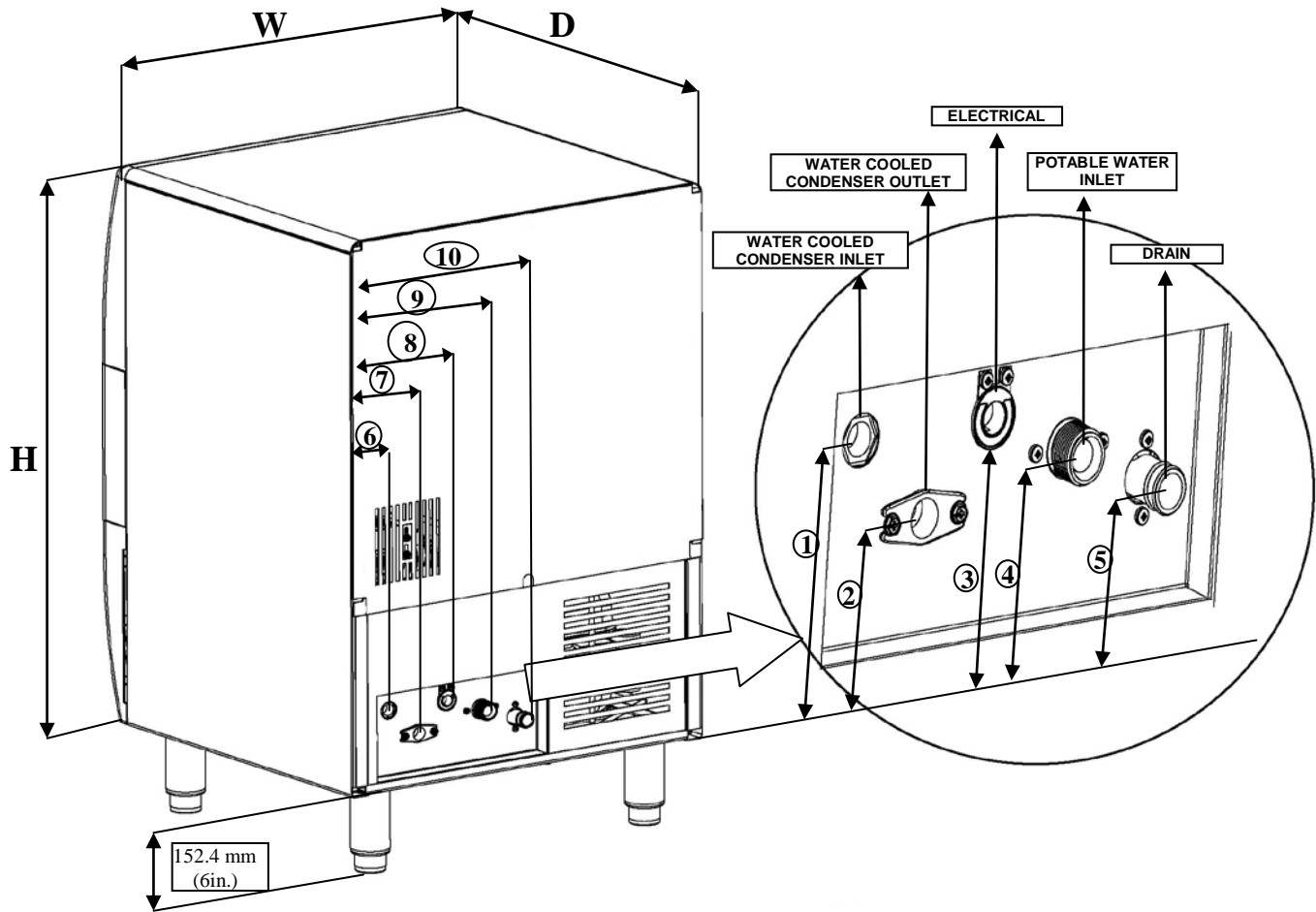

MODEL		H	W	D	Condenser Water Inlet		Condenser Water Outlet		Potable Water Inlet		Drain		Electrical	
					1	6	2	7	4	9	5	10	3	8
EC018	MM	635	343	420	NA	NA	NA	NA	63.5	88.9	50.8	140	76.2	38.1
	INCH	25.0	13.5	16.5	NA	NA	NA	NA	2.5	3.5	2.0	5.5	3.0	1.5
EC020 & EC030	MM	650	450	475	100.5	53.4	45.5	138.4	125.5	118.4	45.3	225	125.5	183.4
	INCH	25.59	17.72	18.7	3.96	2.1	1.79	5.45	4.94	4.66	1.78	8.86	4.94	7.22
EC040 & EC050	MM	800	550	550	108	77.5	68	123	87.5	221	68	275	108	168
	INCH	31.5	21.65	21.65	4.25	3.05	2.68	4.82	3.44	8.71	2.68	10.83	4.25	6.59
EC065 & EC080	MM	902	700	600	114.3	82.6	76.2	120.7	95.25	222.25	82.6	279.4	120.7	171.5
	INCH	35.5	27.5	23.5	4.5	3.25	3.0	4.75	3.75	8.75	3.25	11.0	4.75	6.75

Installation Checklist

- Is the ice machine level?
- Has all of the internal packing been removed?
- Have all of the electrical and water connections been made?
- Has the supply voltage been tested and checked against the rating on the nameplate?
- Are all components installed as shown in Section 3? Water spray bar, ice chute, water curtain and sump drain overflow tube are all in place?
- Has the ice machine been installed where ambient temperatures will remain in the range of 10° - 43°C (50° - 110°F)?
- Has the ice machine been installed where the incoming water temperature will remain in the range of 10° - 32°C (50° - 90°F)?
- Is there a separate drain line for the water-cooled condenser?
- Are all electrical leads free from contact with refrigeration lines and moving equipment?
- Has the owner/operator been instructed regarding maintenance and the use of Manitowoc Cleaner and Sanitizer?
- Has the owner/operator completed the warranty registration card?
- Has the ice machine and bin been sanitized?
- Has this manual been given to the owner/operator?
- Is the ice -off - wash switch set to the ice position?

Before Starting the Ice Machine

All ice machines are factory-operated and adjusted before shipment. Normally, new installations do not require any adjustment.

To ensure proper operation, follow the Operational Checks in section 3 of this manual. Starting the ice machine and completing the Operational Checks are the responsibilities of the owner/operator.

Adjustments and maintenance procedures outlined in this manual are not covered by the warranty.



WARNING

PERSONAL INJURY POTENTIAL

Do not operate equipment that has been misused, abused, neglected, damaged, or altered/modified from that of original manufactured specifications.

Component Identification

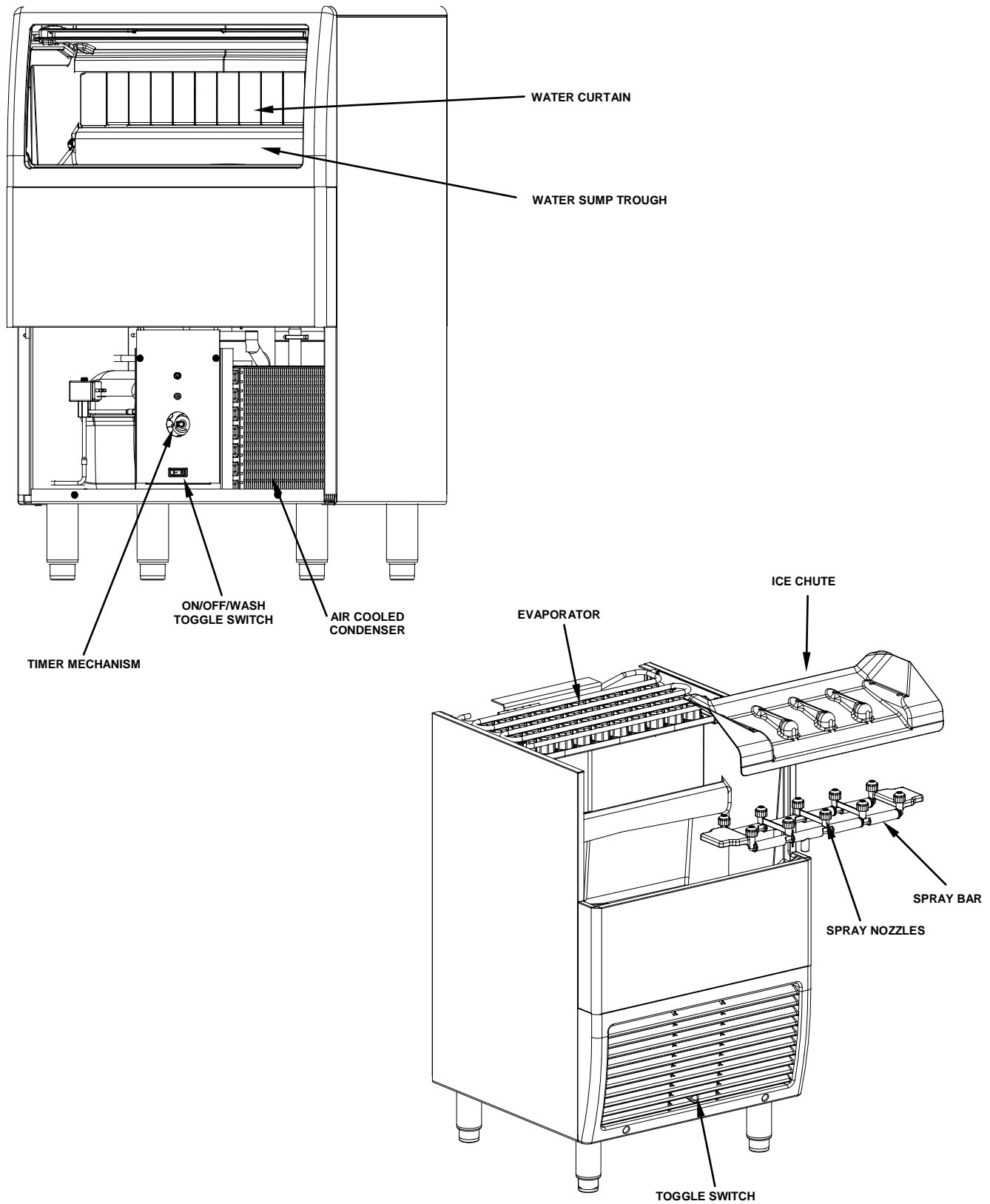

Top Cover

For easiest access to the evaporator compartment, the top cover can be removed.

1. Remove two screws on the rear of the ice machine.
2. Slide top cover back to disengage the three pins from the front panel.

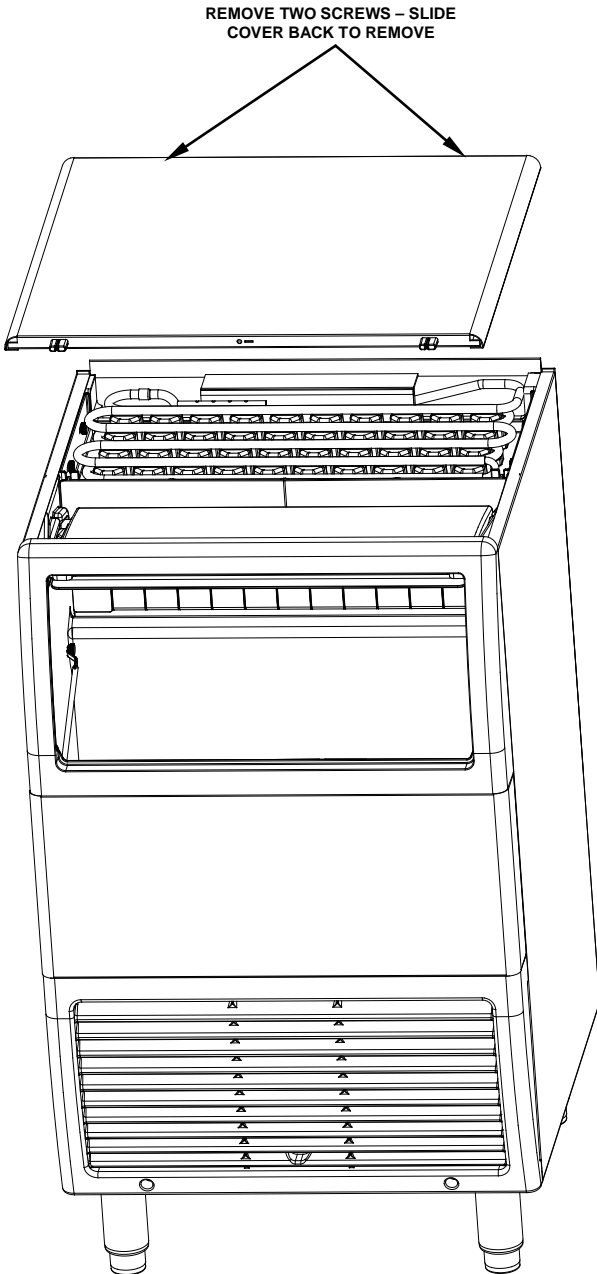

Bin Door

Allows access to the storage bin.

1. Remove top cover.
2. Slide door up until rear pins align with slot in door tracks.
3. Lift rear door pins out and slide door up until front door pins align with slot
4. Lift door out of door track.

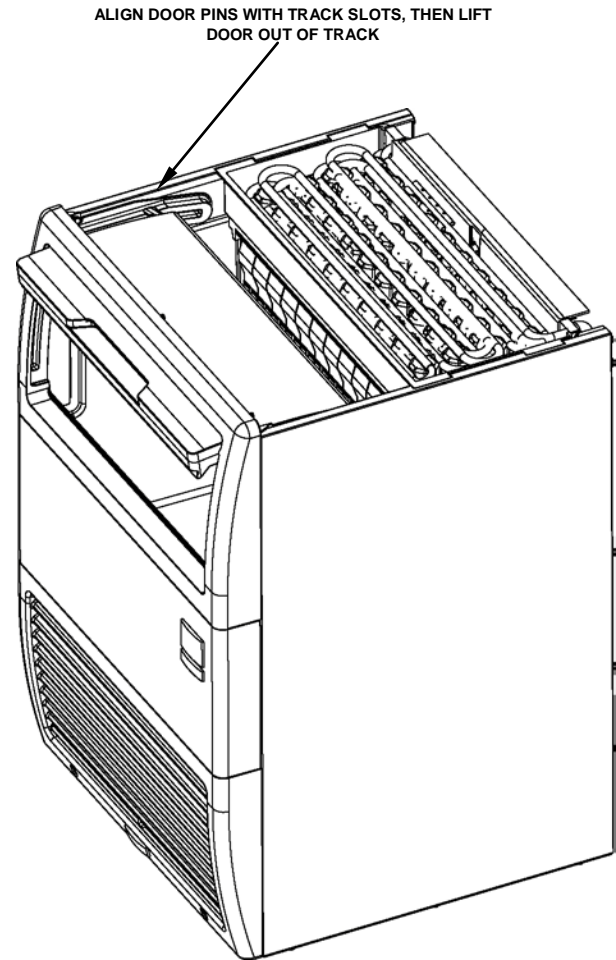

Water Curtain

The ice curtain is designed to keep the spraying water from escaping the evaporator compartment. Removal of the bin door is not required, but enhances access.

1. Grasp one end of the ice curtain and lift up.
2. Pivot water curtain and disengage remaining end.
3. To re-install into ice machine, grasp one end of the water curtain, install one end, pivot the opposite end and pull down into position. Make sure tabs are secure in grooves.

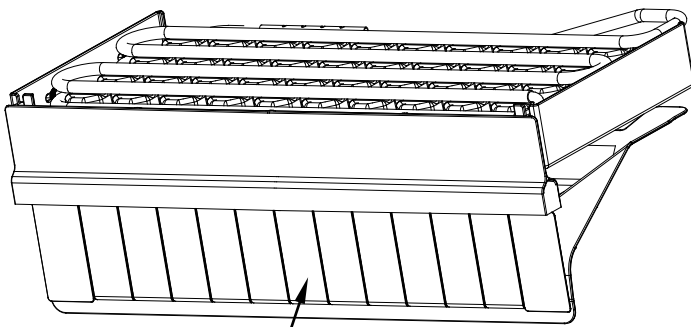

WATER CURTAIN

Ice Chute

The ice chute is positioned over the spray nozzles and allows the ice to easily fall into the bin. It must be firmly positioned on the Water Distribution Assembly, with the front edge inside the water trough or the spray nozzles will not be aligned with the spray holes, and spray water will fall into bin.

1. Grab protruding spray holes on one end and lift up.
2. Pivot ice chute and remove.
3. To re-install ice chute, grasp protruding spray holes and position over Water Distribution Assembly. Make sure rear supports are over Water Distribution Assembly, and front edge is inside of water trough.

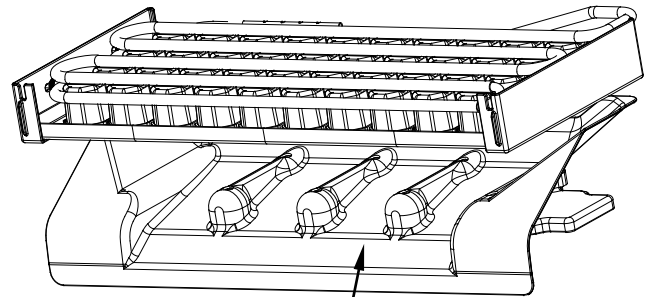

ICE CHUTE

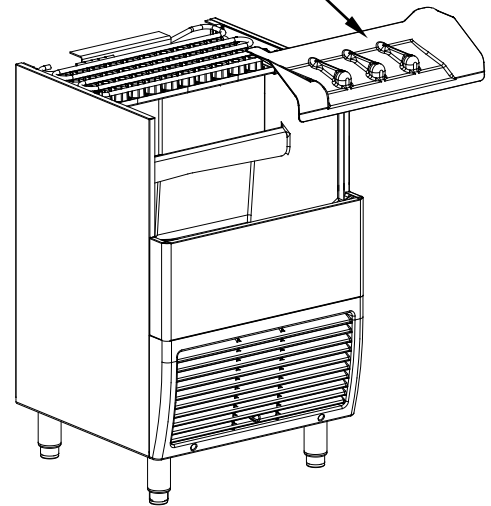

Spray Bar

The spray bar supplies water to the individual ice-making cups. Water from the Water Pump sprays through the nozzles, located on the upper portion of the tubes.

1. Grasp one end of the spray bar, lift up and remove from seat formed in water trough.
2. Remove both plastic clips on water inlet tubing by grasping both ears on clip and separating
3. Apply food grade lubricate to ease re-assembly of spray bar components when necessary.
4. To re-install spray bar, position water inlet tubing on inlet ports, and squeeze clips until tight.
5. Reposition assembly on water trough seat.

Nozzles and inserts can be removed for cleaning by unscrewing nozzles. Inserts are located inside the spray bar ports. The spray bar also disassembles for easy cleaning.

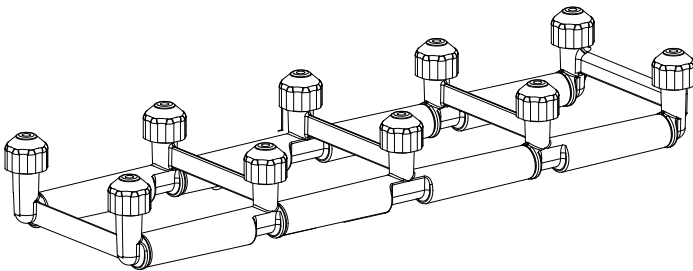

Sump Drain Overflow Tube

The sump drain overflow tube is located in the evaporator water sump.

1. Remove shutters and ice chute.
2. Lift spray bar or disconnect and remove for easiest access.
3. Pull up on over flow tube to remove.
4. To replace plug, insert in hole, and push with force to make a tight seal.

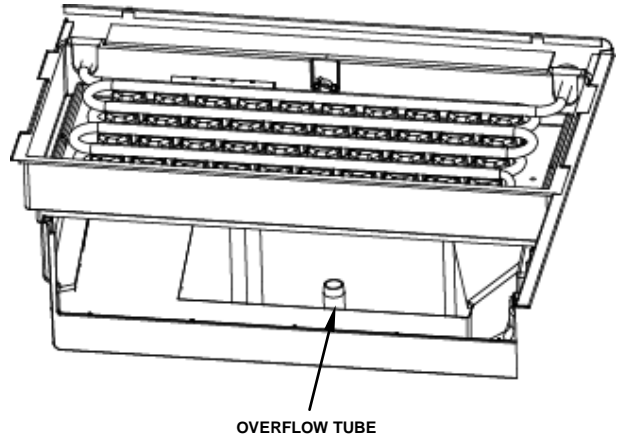

Door Frame

It is not necessary to remove the door frame to clean the ice machine.

1. Remove top cover and bin door.
2. Remove two screws (1 on each side of door track).
3. Lift door track out of ice machine.

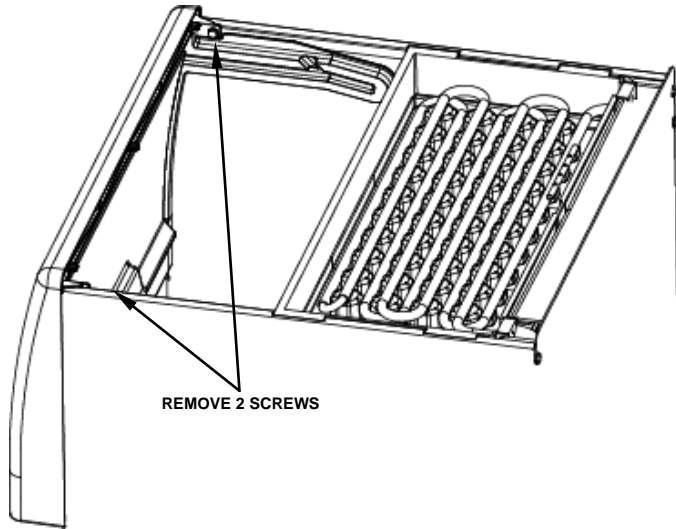

PAGE INTENTIONALLY LEFT BLANK

Ice Machine Operation

Ice Making Sequence of Operation

Important

Prior to start up of this machine, a thorough cleaning and sanitization should be performed. Follow instructions in the maintenance section of this manual.

Initial Start-Up

1. Water Inlet

Turn the toggle switch to wash/fill, the water fill valve and pump are energized, wait for 90 seconds, then turn the switch to off position. The water inlet valve on this machine energizes in the harvest cycle, therefore priming the system with water will allow the system to start up next cycle with a full reservoir of water.

2. Freeze Cycle

Turn the on/off/wash switch to on. The compressor, and water pump will start, thus starting the freezing cycle. The pump sprays water into the inverted cups. The water freezes layer by layer, until an ice cube forms in each cup.

At the same time the compressor starts, the condenser fan motor (air-cooled models) is supplied with power throughout the freeze and harvest cycles. The freeze cycle continues and the evaporator thermostat reaches the adjusted set point.

- EC18/20

A harvest cycle starts.

- EC30/40/50/65/80

The thermostat energizes the time delay relay. When the timer reaches setpoint (10 minutes factory setting) the harvest cycle is initiated.

3. Harvest Cycle

The compressor continues to operate and the water pump is de-energized. The hot gas valve energizes, allowing hot gas to enter and warm the evaporator. The water valve is also energized, aiding with harvest, as well as filling up the sump with fresh water for a new freeze cycle.

The ice falls from the cups and is directed into the bin by the ice chute. The harvest cycle continues until:

- EC18/20

The evaporator thermostat changes position.

- EC30/40/50/65/80

The timer reaches the factory setting of 3 minutes.

The hot gas valve, and water valve de-energize. If ice cubes are not contacting the bin thermostat a new freeze cycle is initiated as the water pump energizes and sprays water into the cups.

4. Automatic Shut-Off

When the storage bin is full, the ice will come in contact with the bin thermostat which is located inside the bin. The machine will stop after approximately one minute of continuous ice contact with the bin thermostat probe.

The ice machine remains off until enough ice has been removed from the storage bin to allow the ice to fall clear of the bin thermostat probe. As the ice clears the probe, the bin thermostat warms up and the machine starts another freeze cycle.

Operational Checks

GENERAL

Your ice machine was factory-operated and adjusted before shipment. Normally, a newly installed ice machine does not require any adjustment.

To ensure proper operation, always follow these Operational Checks when starting the ice machine:

- for the first time
- after a prolonged out of service period
- after cleaning and sanitizing

Routine adjustments and maintenance procedures outlined in this manual are not covered by the warranty.

Important

It is recommended that adjustments made to this ice machine be made by a qualified technician. Improper adjustment, may seriously affect the life of this ice machine.

ICE CUBE THICKNESS CHECK

The ice cube thickness is factory-set to maintain the ice cube thickness at the proper size and weight.

1. Allow the ice machine to operate for three complete cycles. The cubes should have a small dimple in the center
2. Cycle times vary, according to surrounding air and water inlet temperatures.
3. If cubes are not full (large dimple), turn evaporator thermostat one increment towards the right to increase cube size. Allow ice machine to complete three cycles. Check cube
4. If cubes are too full, (no dimple), turn evaporator thermostat one increment towards the left to decrease cube size. Allow ice machine to operate three complete cycles.



CUBE SHAPE

The standard cube has an average weight of 19 grams, while the large cube has an average weight of 32 grams. Notice the normal dimple in the center of the cube.

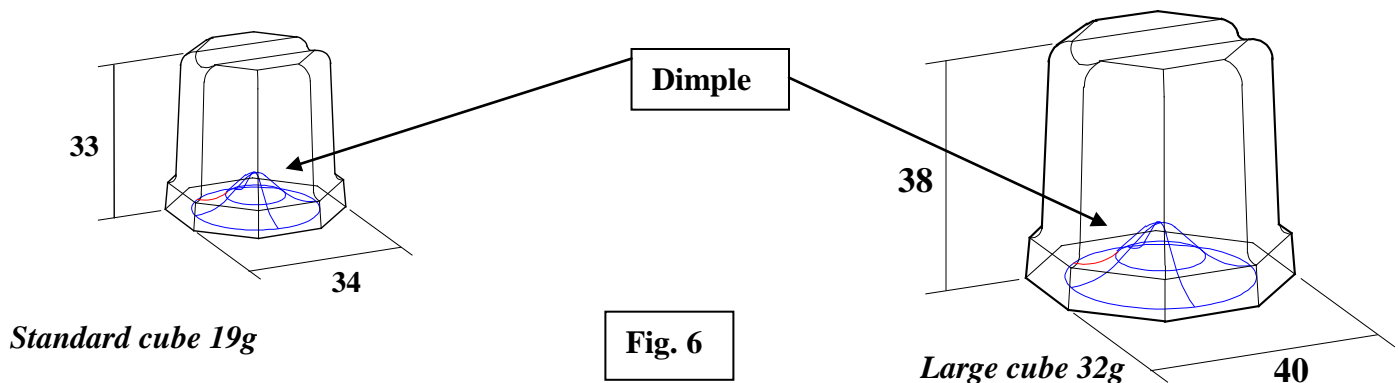

Section 4 Maintenance

General

The end user is responsible for maintaining the ice machine in accordance with the instructions in this manual. Maintenance procedures are not covered by the warranty.



WARNING

If you do not understand the procedures or the safety precautions that must be followed, call your local service representative to perform the necessary maintenance procedures for you.

Basic hygiene and maintenance of your Ice Machine, will increase its reliability, increase performance, and help save on water and power consumption. Ice production will be maintained within the manufacturers guidelines, and unwanted repairs due to maintenance issues will be minimized.

The chart below is an overview of the maintenance that the end user and service technician should perform, and the frequency. These figures are the minimum required. If the Ice Machine is supplied with hard water, more frequent evaporator cleaning should be performed. If the condenser air filter is totally blocked, after one week, more frequent cleaning is recommended.

Maintenance	Weekly	Monthly	Semi Annual	Annual	After prolonged shutdown	At Start-up
Clean cabinet exterior	X				X	X
Sanitize Ice Bin			X		X	X
Clean Evaporator			X	S	S	
Sanitize Evaporator			X	S	S	S
Clean Condenser Coil			X	S	S	
Check Ice Quality	X			S	S	S

X = End User

S = Service Company

Cleaning the Condenser

WARNING

Disconnect electric power to the ice machine at the electric service switch before performing maintenance on equipment.

AIR-COOLED CONDENSER

A dirty condenser restricts airflow, resulting in excessively high operating temperatures. This reduces ice production and shortens component life.

Clean the condenser at least every six months.

1. Remove Plastic Front Grill removing two Phillips head screws. Clean Grill openings before replacing.
2. Clean the outside of the condenser with a soft brush or a vacuum with a brush attachment. Clean from top to bottom, not side to side. Be careful not to bend the condenser fins.
3. Shine a flashlight through the condenser to check for dirt between the fins. If dirt remains:
 - A. Blow compressed air through the condenser fins. Be careful not to bend the fan blades.
 - B. If dirt or grease remains between fins, consult your service representative.
4. Straighten any bent condenser fins with a fin comb.

WARNING

The condenser fins are sharp. Use care when cleaning them.

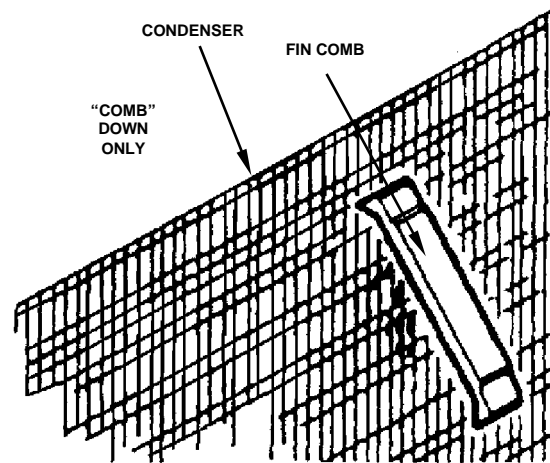

WATER-COOLED CONDENSER AND WATER REGULATING VALVE

The water-cooled condenser and water-regulating valve may require cleaning due to scale build-up.

Low ice production, high water consumption and high operating temperatures and pressures all may be symptoms of restrictions in the condenser water circuit.

Because the cleaning procedures require special pumps and cleaning solutions, qualified maintenance or service personnel must perform them.

Interior Cleaning and Sanitizing

GENERAL

Clean and sanitize the ice machine every six months for efficient operation. If the ice machine requires more frequent cleaning and sanitizing, consult a qualified service company to test the water quality and recommend appropriate water treatment.

If required, an extremely dirty ice machine may be taken apart for cleaning and sanitizing.

 **CAUTION**

Use only approved Ice Machine Cleaner and Sanitizer. Read and understand all labels printed on bottles before use. Do not mix Ice Machine Cleaner and Sanitizer solutions together

 **WARNING**

Wear rubber gloves and safety goggles (and/or face shield) when handling Ice Machine Cleaner or Sanitizer.

CLEANING PROCEDURE

Ice machine cleaner is used to remove lime scale or other mineral deposits. It is not used to remove algae or slime. Refer to “Sanitizing Procedure” on the next page for removal of algae and slime.

Cleaner	Water
500 ml (16 oz)	4 l (1 gal)

Mix 4 liters of water with 500 ml of cleaner in a plastic or stainless container.

Step 1 Set the toggle switch to the OFF position at the end of a Harvest Cycle, after ice releases from the evaporator. Or, set the switch to the OFF position and allow the ice to melt off the evaporator.

 **CAUTION**

Never use anything to force ice from the evaporator. Damage may result.

Step 2 Remove all ice from the bin.

 **WARNING**

Disconnect electric power to the ice machine at the electric switch box before proceeding.

Step 3 Remove all parts as described in Section 3, Component Identification & Removal.

Step 4 Take all components to sink and with 2 liters Cleaner/Water mixture clean all components with a soft nylon brush. Disassemble spray bar, remove nozzles and inserts and soak for 5 minutes. For heavily scaled parts, soak in solution for 15–20 minutes. Rinse all components with clean water.

Step 5 While components are soaking, use nylon brush to scrub inside of ice bin. Scrub inside of door, door track, bin, sump trough, and evaporator moldings. With clean water, rinse all of these areas thoroughly.

Step 6 Replace sump overflow tube and pour remaining 2 liters of mixture into the water sump. Replace all parts.

Step 7 Disconnect the incoming ice-making water line.

Step 8 To start a cleaning cycle, set the toggle switch to the WASH position.

Step 9 After 10 minutes, set the toggle switch to the OFF position. Remove water curtain, ice chute and over flow tube from the water sump. Allow all water to drain from the sump. Replace drain plug and fill sump with 2 liters of water. Set toggle switch to Wash and circulate for 10 minutes.

Step 10 After 10 minutes, set toggle switch to off position. Remove water curtain, ice chute, water sump over flow tube. Drain water from sump and replace tube.

Sanitizer	Water
60 ml (1 oz)	12 l (3 gal)

Mix 4 liters of water with 30 ml of sanitizer in a plastic or stainless container.

Step 11 Set the toggle switch to the OFF position at the end of a harvest cycle, after ice releases from the evaporator. Or, set the switch to the OFF position and allow the ice to melt off the evaporator.

 CAUTION Never use anything to force ice from the evaporator. Damage may result.

Step 12 Remove all ice from the bin.

Step 13 Remove Water Curtain and Ice Chute as described in Section 3, Component Identification & Removal.

Step 14 Take all components to sink and with 2 liters Sanitizer/Water mixture clean all components with a soft nylon brush. Rinse all Components with clean water.

Step 15 Use brush to scrub inside of ice bin. Scrub inside of door, door track, bin, water sump, water distribution assembly and evaporator moldings. With clean water, rinse all of these areas thoroughly.

Step 16 Replace sump drain over flow tube, and transfer remaining 2 liters of solution to the sump trough. Replace all components.

Step 17 To start a sanitizing cycle, set the toggle switch to the WASH position.

Step 18 After 10 minutes, set the toggle switch to the OFF position. Remove water curtain and ice chute Remove over flow tube from water sump. Allow all water to drain from sump. Replace over flow tube and fill sump with 2 liters of water. Set toggle switch to Wash and allow circulation for 10 minutes.

Step 19 Replace all parts. Connect the incoming ice-making water line.

Step 20 Place toggle switch in WASH/FILL for 90 seconds and then to ICE position, ice machine will go into ice making cycle.

Exterior Cleaning

Clean the area around the ice machine as often as necessary to maintain cleanliness and efficient operation.

Sponge any dust and dirt off the outside of the ice machine with mild soap and water. Wipe dry with a clean, soft cloth.

A commercial grade stainless steel cleaner and polish may be used.

Removal from Service/Winterization

GENERAL

Special precautions must be taken if the ice machine is to be removed from service for an extended period of time or exposed to ambient temperatures of 32°F (0°C) or below.



CAUTION

If water is allowed to remain in the ice machine in freezing temperatures, severe damage to some components could result. Damage of this nature is not covered by the warranty.

Follow the applicable procedure below.

AIR-COOLED ICE MACHINES

1. Disconnect the electric power at the circuit breaker or the electric service switch.
2. Turn off the water supply.
3. Drain the water from the water sump and water pump by disconnecting the water pump tubing.
4. Disconnect and drain the incoming ice-making water line and disconnect the tubing from the water inlet valve outlet and allow water to drain.
5. Blow compressed air in the drain opening and water valve outlet hose, then reattach.
6. Make sure water is not trapped in any of the water or drain lines.

WATER-COOLED ICE MACHINES

1. Perform steps 1-6 under "Air-Cooled Ice Machines."
2. Disconnect the incoming water and drain lines from the water-cooled condenser.
3. Insert a large screwdriver between the bottom spring coils of the water regulating valve. Pry upward to open the valve.

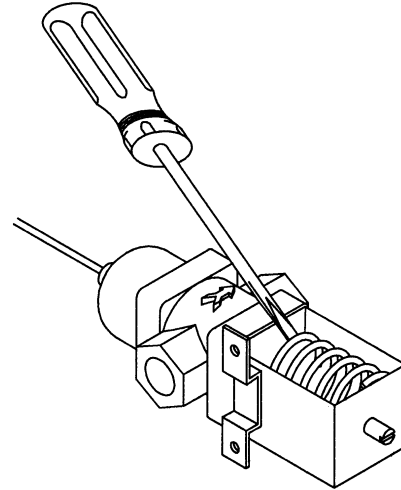

Pry Open the Water Regulating Valve

4. Hold the valve open and blow compressed air through the condenser until water no longer exits.

SV1624

Before Calling for Service

If a problem arises during operation of your ice machine, follow the chart below before calling for service. Routine adjustments and maintenance procedures are not covered by the warranty.

Problem	Cause	Correction
Ice Machine Will Not Run		
	Toggle switch is not in ice position	Place toggle switch in ice position
	No Power – Breaker off, fuse blown, unplugged	Restore power
	Bin Thermostat incorrectly adjusted	Adjust bin thermostat
Ice machine runs and no ice is produced	No water to ice machine	Correct water supply
	Water sump overflow tube out of position	Reposition/install overflow tube
	Evaporator thermostat incorrectly adjusted or faulty	Adjust or replace evaporator thermostat
Freeze cycle long – low production	Dirty condenser	Clean condenser
	Water temperature too high	Connect to a cold water supply, verify check valves in faucets and other equipment work properly
	Refrigeration problem	Call for service
Freeze Cycle		
Shallow, incomplete or white ice cubes	Ice machine is dirty	Clean & sanitize the ice machine
	Water pressure supply incorrect	Verify water pressure is correct
	Air temperature around ice machine is too high	Vent area or move ice machine
	Evaporator thermostat incorrectly adjusted	Adjust evaporator thermostat
Harvest Cycle		
Will not initiate a harvest cycle	Evaporator thermostat incorrectly adjusted or faulty	Adjust or replace evaporator thermostat
	Timer Problem	Call for service
Ice cubes do not release	Ice machine is dirty	Clean and sanitize the ice machine
	Low ambient around ice machine	Adjust timer or move ice machine to warmer area
	Evaporator thermostat incorrectly adjusted (cubes too large)	Adjust evaporator thermostat

Owner Warranty Registration Card

GENERAL

The packet containing this manual also includes warranty information. Warranty coverage begins the day your new ice machine is installed.

Important

Complete and mail the OWNER WARRANTY REGISTRATION CARD as soon as possible to validate the installation date.

If you do not return your OWNER WARRANTY REGISTRATION CARD, the date of sale to the Manitowoc Distributor will be used as the first day of warranty coverage for your new ice machine.

Warranty Coverage

GENERAL

The following Warranty outline is provided for your convenience. For a detailed explanation, read the warranty bond shipped with each product.

Contact your local Manitowoc representative or Manitowoc Ice if you need further warranty information.

PARTS

1. Manitowoc warrants the ice machine against defects in materials and workmanship, under normal use and service for two (2) years from the date of original installation.

LABOR

1. Labor required to repair or replace defective components is covered for one (1) year from the date of original installation.

AUTHORIZED WARRANTY SERVICE

To comply with the provisions of the warranty, a refrigeration service company qualified and authorized by your distributor must perform the warranty repair.

NOTE: If the dealer you purchased the ice machine from is not authorized to perform warranty service, contact your distributor for the name of the nearest authorized service representative.

EXCLUSIONS

The following items are not included in the ice machine's warranty coverage:

1. Normal maintenance, adjustments and cleaning.
2. Repairs due to unauthorized modifications to the ice machine or use of non-standard parts without prior written approval from the manufacturer.
3. Damage caused by improper installation of the ice machine, electrical supply, water supply or drainage, or damage caused by floods, storms, or other acts of God..
4. Parts or assemblies subjected to misuse, abuse, neglect or accidents.
5. Damage or problems caused by installation, cleaning and/or maintenance procedures inconsistent with the technical instructions provided in this manual.
6. **Premium labor rates** due to holidays, **overtime**, etc.; travel time; flat rate service call charges; mileage and miscellaneous tools and material charges not listed on the payment schedule. Additional labor charges resulting from the inaccessibility of equipment are also excluded

SERVICE CALLS

Normal maintenance, adjustments and cleaning as outlined in this manual are not covered by the warranty. If you have followed the procedures listed on the "Before Calling For Service" chart in this manual, and the ice machine still does not perform properly, call your authorized service company.

We reserve the right to make product improvements at any time.
Specifications and design are subject to change without notice.

EC DECLARATION OF CONFORMITY

We hereby declare that our products, ice machines and Multiplex refrigeration equipment comply with all the essential requirements of the listed EC- directives.

Manufacturer:

Manitowoc Ice, Inc.
2110 South 26th Street
Manitowoc Wisconsin 5421-1720

European Distributor:

Representative Of Manitowoc Ice, Inc:

Randy Haack, Engineering Manager

Randy Haack

Representative of European Distributor:

Model and Serial No.

Applied EC Directives:

Low Voltage 73/23/EEC
EMC 89/336/EEC
Pressure Equipment 97/23/EC

Applied Standards

EN60335-1 Safety of household and similar electrical appliances
EN60335-2-24 Particular requirements refrigerators, food freezers and ice makers
EN378-1 to -4 Refrigeration plants

EN55014 Electrical Motor Operated Appliances (Emissions)
EN55104 Electro magnetic compatibility (Immunity)

CE 05

8201043

MANITOWOC ICE

Website - www.manitowocice.com

©2010 Manitowoc Ice