



Indigo™ Series QuietQube Ice Machine

Technician's Handbook



Safety Notices

Read these precautions to prevent personal injury:

- Read this manual thoroughly before operating, installing or performing maintenance on the equipment. Failure to follow instructions in this manual can cause property damage, injury or death.
- Routine adjustments and maintenance procedures outlined in this manual are not covered by the warranty.
- Proper installation, care and maintenance are essential for maximum performance and trouble-free operation of your equipment.
- Visit our website www.manitowocice.com for manual updates, translations, or contact information for service agents in your area.
- This equipment contains high voltage electricity and refrigerant charge. Installation and repairs are to be performed by properly trained technicians aware of the dangers of dealing with high voltage electricity and refrigerant under pressure. The technician must also be certified in proper refrigerant handling and servicing procedures. All lockout and tag out procedures must be followed when working on this equipment.
- This equipment is intended for indoor use only. Do not install or operate this equipment in outdoor areas.
- As you work on this equipment, be sure to pay close attention to the safety notices in this handbook. Disregarding the notices may lead to serious injury and/or damage to the equipment.

Warning

Follow these electrical requirements during installation of this equipment.

- All field wiring must conform to all applicable codes of the authority having jurisdiction. It is the responsibility of the end user to provide the disconnect means to satisfy local codes. Refer to rating plate for proper voltage.
- This appliance must be grounded.
- This equipment must be positioned so that the plug is accessible unless other means for disconnection from the power supply (e.g., circuit breaker or disconnect switch) is provided.
- Check all wiring connections, including factory terminals, before operation. Connections can become loose during shipment and installation.

Warning

Follow these precautions to prevent personal injury during installation of this equipment:

- Installation must comply with all applicable equipment fire and health codes with the authority having jurisdiction.
- To avoid instability the installation area must be capable of supporting the combined weight of the equipment and product. Additionally the equipment must be level side to side and front to back.
- Ice machines require a deflector when installed on an ice storage bin. Prior to using a non-OEM ice storage system with this ice machine, contact the bin manufacturer to assure their ice deflector is compatible.
- Remove all removable panels before lifting and installing and use appropriate safety equipment during installation and servicing. Two or more people are required to lift or move this appliance to prevent tipping and/or injury.
- Do not damage the refrigeration circuit when installing, maintaining or servicing the unit.
- Connect to a potable water supply only.
- This equipment contains refrigerant charge.
- Installation of the line sets must be performed by a properly trained and EPA certified refrigeration technician aware of the dangers of dealing with refrigerant charged equipment.

Warning

Follow these precautions to prevent personal injury while operating or maintaining this equipment.

- Legs or casters must be installed and the legs/casters must be screwed in completely. When casters are installed the mass of this unit will allow it to move uncontrolled on an inclined surface. These units must be tethered/secured to comply with all applicable codes. Swivel casters must be mounted on the front and rigid casters must be mounted on the rear. Lock the front casters after installation is complete.
- Some 50 Hz models may contain up to 150 grams of R290 (propane) refrigerant. R290 (propane) is flammable in concentrations of air between approximately 2.1% and 9.5% by volume (LEL lower explosion limit and UEL upper explosion limit). An ignition source at a temperature higher than 470°C is needed for a combustion to occur.
- Refer to nameplate to identify the type of refrigerant in your equipment.
- Only trained and qualified personnel aware of the dangers are allowed to work on the equipment.
- Read this manual thoroughly before operating, installing or performing maintenance on the equipment. Failure to follow instructions in this manual can cause property damage, injury or death.
- Crush/Pinch Hazard. Keep hands clear of moving components. Components can move without warning unless power is disconnected and all potential energy is removed.
- Moisture collecting on the floor will create a slippery surface. Clean up any water on the floor immediately to prevent a slip hazard.

Warning

Follow these precautions to prevent personal injury while operating or maintaining this equipment.

- Objects placed or dropped in the bin can affect human health and safety. Locate and remove any objects immediately.
- Never use sharp objects or tools to remove ice or frost.
- Do not use mechanical devices or other means to accelerate the defrosting process.
- When using cleaning fluids or chemicals, rubber gloves and eye protection (and/or face shield) must be worn.

DANGER

Do not operate equipment that has been misused, abused, neglected, damaged, or altered/modified from that of original manufactured specifications. This appliance is not intended for use by persons (including children) with reduced physical, sensory or mental capabilities, or lack of experience and knowledge, unless they have been given supervision concerning use of the appliance by a person responsible for their safety. Do not allow children to play with, clean or maintain this appliance without proper supervision.

DANGER

Follow these precautions to prevent personal injury during use and maintenance of this equipment:

- It is the responsibility of the equipment owner to perform a Personal Protective Equipment Hazard Assessment to ensure adequate protection during maintenance procedures.
- Do Not Store Or Use Gasoline Or Other Flammable Vapors Or Liquids In The Vicinity Of This Or Any Other Appliance. Never use flammable oil soaked cloths or combustible cleaning solutions for cleaning.
- All covers and access panels must be in place and properly secured when operating this equipment.
- Risk of fire/shock. All minimum clearances must be maintained. Do not obstruct vents or openings.
- Failure to disconnect power at the main power supply disconnect could result in serious injury or death. The power switch DOES NOT disconnect all incoming power.
- All utility connections and fixtures must be maintained in accordance with the authority having jurisdiction.
- Turn off and lockout all utilities (gas, electric, water) according to approved practices during maintenance or servicing.
- Units with two power cords must be plugged into individual branch circuits. During movement, cleaning or repair it is necessary to unplug both power cords.

Table of Contents

General Information

How to Read a Model Number	15
Head Sections.....	15
ICVD Condensing Units.....	16
Ice Cube Sizes	16
Model/Serial Number Location	17
Model Numbers	18
QuietQube® Models	18
Ice Machine Warranty Information	19
LuminIce® II	19

Installation

Stacking Two Ice Machines on a Single Storage Bin	21
Ice Deflector	21
Location of Ice Machine	22
Head Section.....	22
Ice Beverage Models	23
Location of ICVD Condensing Units	24
Clearance Requirements	25
Ice Machine Heat of Rejection	26
I1470C/I1870C/I2170C/I2176C	
Installation on a Manitowoc Bin	27
Ice Machine on a Dispenser Installation	28
Lineset Applications	29
QuietQube® Remote Condensing Unit	30
ICVD Transformer Wiring.....	31
ICVD Interconnecting Wiring.....	31
Additional Refrigerant Charge For	
51' to 100' Line Sets	32

Maintenance

Cleaning and Sanitizing	35
General	35
Cleaning/Sanitizing Procedure.....	37
Preventative Maintenance Cleaning Procedure.....	37
Exterior Cleaning.....	37
Cleaning / Sanitizing Procedure	38

Cleaning Procedure	38
Sanitizing Procedure	41
Parts Removal for Cleaning/Sanitizing.....	44
Removal from Service/Winterization	53
Air-Cooled Ice Machines	53

Operation

Control Panel Features.....	55
Buttons	55
Display Panel.....	56
Menu Navigation Overview.....	57
Display Panel Navigation	58
Alerts and Messages	60
Main Menu	61
Machine Info Menu	62
Password Entry	63
Reset Password To Factory Defaults	65
Set-Up Menu.....	66
Language	67
Time & Date.....	68
Units.....	69
Ice Clarity	69
LCD Brightness.....	70
Password On	70
Edit Password	70
Clean Minder.....	71
IAuCS Runtime	71
Air Filter.....	72
Water Filter.....	73
LuminIce® Reminder.....	74
Ice Bin Level Sensor	75
Factory Defaults.....	75
Energy Saver Menu	76
Ice Program	77
ICE Bin Level Sensor	78
USB Setup.....	78
Water Miser	79
Statistics	79
Service Menu	80
Data History.....	82
Real Time Data	83

Diagnostics	85
Manual Harvest	86
Replace Control Board.....	86
USB Setup.....	87
Event Log Menu.....	87
Event Log	88
USB Flash Drive Specifications and Formatting.....	94
Upgrading Firmware with a Flash Drive	96
Exporting Data to a Flash Drive	98
Operational Checks	100
General	100
Ice Thickness Check	101
Sequence of Operation	103
QuietQube® Models	103
Initial Start-Up or Start-Up After Automatic Shut-Off.....	103
Freeze Sequence	104
Harvest Sequence	105
Automatic Shut-Off.....	106
Restart After Automatic Shut-off	106
Safety Timers.....	109
Water Assist Harvest Feature	110

Troubleshooting

Safety Limits	111
Safe Operation Mode.....	112
Ice Thaw Cycle.....	113
Analyzing Why a Safety Limit Stopped the Ice Machine	114
Safety Limit #1	114
Safety Limit #2	116
Troubleshooting By Symptom	117
Reset To Factory Defaults	118
Symptom #1 Ice Machine Will Not Run	119
Diagnosing a Condensing Unit That Will Not Run.....	122
Symptom #2 Low Production, Long Freeze Cycle.....	123
Freeze Cycle Refrigeration System Operational Analysis Tables.....	125

Freeze Cycle Refrigeration System	
Operational Analysis Table Procedures -	
QuietQube® Models	131
Symptom #3 Harvest Problems	149
Symptom #3 QuietQube® Models With	
ICVD Condensing Units.....	150
Symptom #4 QuietQube® Models With	
ICVD Condensing Units.....	154

Component Check Procedures

Electrical Components	157
Control Board, Display Board, Touch Pad ..	157
Control Board Relay Test	160
Programming a Replacement Board.....	161
Main Fuse	163
Bin Switch.....	164
Water Level Control Circuitry.....	167
Ice Thickness Probe (Initiates Harvest)....	173
High Pressure Cutout (HPCO) Control	178
Low Pressure Cutout (LPCO) Control	181
Fan Cycle Control.....	182
Thermistors	183
Harvest Assist Air Pump	186
Compressor Electrical Diagnostics	187
Diagnosing Start Components.....	189
Refrigeration Components	192
Head Pressure Control Valve	192
Suction Accumulator Operation	198
Recovery/Evacuation/Charging Procedures	
QUIETQUBE® MODELS	199
Connections	200
Recovery/Evacuation Procedures	201
Charging Procedures	202
System Contamination Clean-Up	203
Determining Severity of Contamination...	203
Cleanup Procedure	205
Replacing Pressure Controls Without	
Removing Refrigerant Charge.....	208
Liquid Line Filter-Driers.....	210
Suction Filter.....	210

Total System Refrigerant Charge	
QuietQube® ICVD Models	211

Charts

Cycle Times/24-Hour Ice Production/ Refrigerant Pressure Charts	213
I0680C/ICVD0695	214
IB0690C/ICVD0695	215
I0686C/ICVD0696	216
IB0696C/ICVD0696	217
I0870C/ICVD0895	218
IB0890C/ICVD0895	219
I0976C/ICVD0996	220
I1070C/ICVD1095	221
I1070C/ICVD1195	222
I1076C/ICVD1195	223
I1176C/ICVD1195	224
IB1090C/ICVD1195	225
I1470C/ICVD1495	226
I1470C/ICVD1496	227
I1870C/ICVD1895	228
I2170C/ICVD2095	229
I2176C/ICVD2096	230

Diagrams

Wiring Diagrams	231
Wiring Diagram Legend	231
All ICVD Models Interconnecting Wiring... ..	232
I0680C/I0686C/I0870C/I0976C/I1070C/ I1176C 1&3ph.....	233
ICVD0695/ICVD0696/ICVD895/ICVD1095/ ICVD1195 1ph.....	234
ICVD0695/ICVD0696/ICVD895/ICVD1095/ ICVD1195 3ph.....	235
IB0690C/IB0696C/IB0890C/IB1090C 1&3ph	236
ICVD0695/ICVD0696/ICVD0895/ICVD0996/ ICVD1195 1ph.....	237
ICVD0695/ICVD0696/ICVD0895/ICVD0996/ ICVD1195 3ph.....	238
I1470C/I1870C/I2170 1&3ph	239
ICVD1495/ICVD1496/ICVD1895 1ph	240

ICVD1495/ICVD1496/ICVD1895 3ph	241
ICVD2095 1ph.....	242
iCVD2095 3ph.....	243
I2176C 1&3ph.....	244
ICVD2096 1ph.....	245
ICVD2096 3ph.....	246
Electronic Control Board.....	247
Refrigeration Tubing Schematics	248
Remote Condensing Unit Models	248
IB Models	249
Dual Evaporator Models	251

General Information

How to Read a Model Number

HEAD SECTIONS

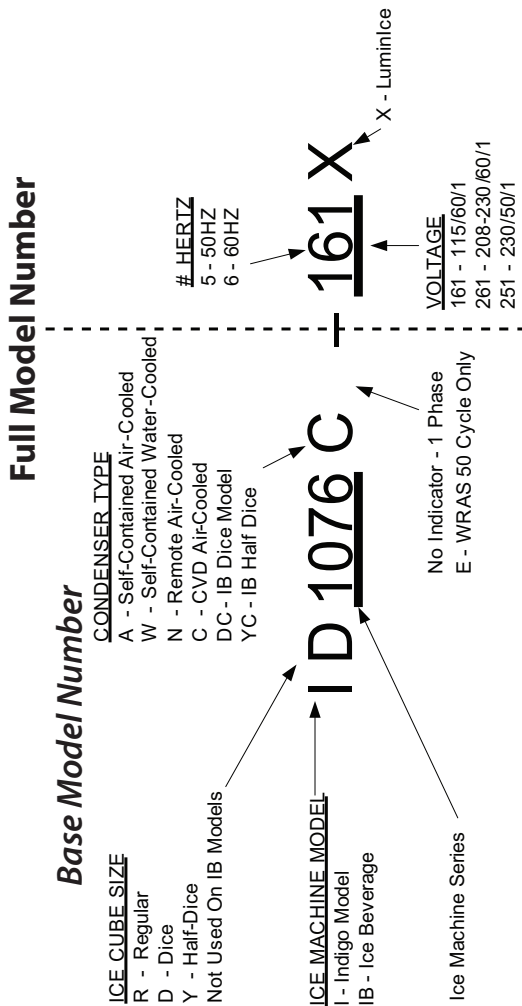

ICVD CONDENSING UNITS

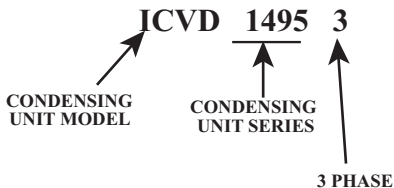

Ice Cube Sizes

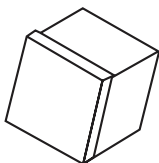

Regular

1-1/8" x 1-1/8" x 7/8"

2.86 x 2.86 x 2.22 cm

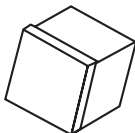

Dice

7/8" x 7/8" x 7/8"

2.22 x 2.22 x 2.22 cm

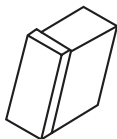

Half Dice

3/8" x 1-1/8" x 7/8"

0.95 x 2.86 x 2.22 cm

⚠ Warning

All Manitowoc ice machines require the ice storage system (bin, dispenser, etc.) to incorporate an ice deflector.

Prior to using a non-Manitowoc ice storage system with other Manitowoc ice machines, contact the manufacturer to assure their ice deflector is compatible with Manitowoc ice machines.

Model/Serial Number Location

These numbers are required when requesting information from your local Manitowoc Distributor, service representative, or Manitowoc Ice, Inc. The model and serial number are listed on the OWNER WARRANTY REGISTRATION CARD. They are also listed on the MODEL/SERIAL NUMBER DECAL affixed to the front and rear of the ice machine.

The model and serial number are located in the Indigo Interface and must match the data plate for proper operation. NOTE: Only a portion of the model number is entered into the display. For example a model number listed on the data plate may show #ID1076C-161X but the display would only show #ID1076C-161. For further detail, see Control Board Replacement/Manual Setup on page 161.

Model Numbers

QUIETQUBE® MODELS

Ice Machine Head Section	ICVD® Condensing Unit
ID0682C - IY0684C IB0694YC	ICVD0695
ID0686C - IY0686C IB0696YC	ICVD0696
ID0872C - IY0874C IB0894YC	ICVD0895
ID0976C - IY0976C	ICVD0996
ID1072C - IY1074C	ICVD1095 ICVD1195
ID1076C - IY1076C	ICVD1195
ID1176C - IY1176C	ICVD1195
IB1094YC	ICVD1195
ID1472C IY1474C	ICVD1496
ID1872C IY1874C	ICVD1895
ID2172C IY2174C	ICVD2095
ID2176C IY2176C	ICVD2096

Ice Machine Warranty Information

For warranty information visit:

<http://www.manitowocice.com/Service/Warranty>

- Warranty Verification
- Warranty Registration
- View and download a copy of the warranty Owner Warranty Registration Card

Warranty coverage begins the day the ice machine is installed.

LuminIce® II

The LuminIce® growth inhibitor recirculates the air in the ice machine foodzone over a UV bulb. This process will inhibit the growth of common micro-organisms on all exposed foodzone surfaces.

- LuminIce® bulbs require replacement on a yearly basis.
- The control board can be set to automatically display a reminder after 12 months.
- A remote light is available for reminder indication.

NOTE: LuminIce® and LuminIce® II bulbs are not interchangeable; verify your model before ordering a replacement bulb.

Cleanup Procedure for Accidental Bulb Breakage

The cleanup procedure is identical to the procedure used to clean up compact fluorescent (CFL) or fluorescent tube lights. These lights contain a small amount of mercury sealed within a glass tube. Breaking these types of lights will release mercury and mercury vapor. The broken bulb can continue to release mercury vapor until it is cleaned up and removed.

The latest EPA procedures can be viewed on their website at www.epa.gov/cfl/cflcleanup.html.

THIS PAGE INTENTIONALLY LEFT BLANK

Installation

Warning

PERSONAL INJURY POTENTIAL

Remove all ice machine panels before lifting.

Warning

I1470C/I1870C/I2170C/I2176C ice machines are not approved for use on Manitowoc B570 bins.

Caution

The ice machine head section must be protected if it will be subjected to temperatures below 32°F (0°C). Failure caused by exposure to freezing temperatures is not covered by the warranty.

Refer to "Removal from Service/Winterization" on page 53

STACKING TWO ICE MACHINES ON A SINGLE STORAGE BIN

Indigo Model ice machines cannot be stacked. However an adapter is available that allows two QuietQube® ice machines to be placed side by side on 60" bins.

ICE DEFLECTOR

An ice deflector is required for all ice machines installed on a bin and may be required by the dispenser manufacture when installed on a dispenser.

Location of Ice Machine

HEAD SECTION

The location selected for the ice machine head section must meet the following criteria. If any of these criteria are not met, select another location.

- The location must be free of airborne and other contaminants.
- The air temperature must be at least 35°F (1.6°C), but must not exceed 110°F (43°C).
- Ice Making Water Inlet - Water Pressure must be at least 20 psi (1.38 bar), but must not exceed 80 psi (5.52 bar).
- The location must not be near heat-generating equipment or in direct sunlight and protected from weather.
- The ice machine must be protected if it will be subjected to temperatures below 32°F (0°C). Failure caused by exposure to freezing temperatures is not covered by the warranty.
Refer to "Removal from Service/Winterization" on page 53.

ICE BEVERAGE MODELS

- Ice/Beverage Ice Machines require that a proper ice level be maintained when installed on a dispenser. Ice Beverage machines ship with a ice level management sensor pre installed.
- The ice machine head is installed with the electrical inlet, water supply inlet, refrigeration tubing and water drain entering from the back of the ice machine.
- The ice machine head section contains a service loop that must remain installed between the ice machine head section and line set. Sufficient tubing length must be available to allow 180° rotation of the ice machine.
- Maintain a 3" space between the back of the ice machine and the back of the dispenser to allow room for the refrigeration line set service loop.
- The water inlet and electrical connection must contain a service loop to allow future service and maintenance access.
- The drain line must contain a union or other suitable means of disconnection at the ice machine head section.
- The location must be free of airborne and other contaminants.
- The air temperature must be at least 35°F (1.6°C), but must not exceed 110°F (43°C).
- The location must not be near heat-generating equipment or in direct sunlight.

LOCATION OF ICVD CONDENSING UNITS

The location selected for the ICVD Condensing Unit must meet the following criteria. If any of these criteria are not met, select another location.

- *ICVD0895/ICVD0996/ICVD1095/ICVD1495/ICVD1496/ICVD1895 Only*
The air temperature must be at least -20°F (-28.9°C) but must not exceed 130°F (54.4°C).
- *ICVD0695/ICVD0696/ICVD1195/ICVD2095/ICVD2096 Only*
The air temperature must be at least -20°F (-28.9°C) but must not exceed 120°F (48.9°C).
- The location must not allow exhaust fan heat and/or grease to enter the condenser.
- The location must not obstruct airflow through or around the condensing unit. See below for clearance requirements.

Clearance Requirements

I0680C - I0686C I0870C - I0976C I1070C	Ice Machine Head Section	ICVD Condensing Unit
Top	5" (12.7 cm)	*0" (0 cm)
Sides	5" (12.7 cm)	*0" (0 cm)
Back Standard Connections	5" (12.7 cm)	48" (122 cm)
Back Connections Out Top	3" (7.6 cm)	N/A
Front	***	48" (122 cm)

I1470C - I1870C I2170C - I2176C	Ice Machine Head Section	ICVD Condensing Unit
Top	5" (12.7 cm)	*0" (0 cm)
Sides	5" (12.7 cm)	*0" (0 cm)
Back Standard Connections	5" (12.7 cm)	48" (122 cm)
Back Connections Out Top	3" (7.6 cm)	N/A
Front	***	24" (61.0 cm)

Ice Beverage Models

IB0690C - IB0890C IB1090C	Ice Machine Head Section	ICVD Condensing Unit
Top	2" (5.1 cm)	*0" (0 cm)
Sides	8" (20.3 cm)	*0" (0 cm)
Back	5" (12.7 cm)	48" (122 cm)
Front	***	48" (122 cm)

*6" (15.2 cm) is recommended for servicing

*** Minimum amounts vary by installation - Access is required for cleaning/sanitizing and ice removal

Ice Machine Heat of Rejection

Series Ice Machine	Heat of Rejection	
	Air Conditioning*	Peak
I0680C - I0686C IB0690C - IB0696C	9000	13900
I0870C - I0976C IB0890C	13000	16000
I1070C	16250	18600
I1176C IB1090C	20700	24500
I1470C	23500	27000
I1870C	30000	35000
I2100 - I2176C	30500	35500

*BTU/Hour

Because the heat of rejection varies during the ice making cycle, the figure shown is an average.

I1470C/I1870C/I2170C/I2176C Installation on a Manitowoc Bin

Dual evaporator models will not function correctly with the stock bin deflector. An ice deflector kit is required for installation and is ordered separate. Order appropriate kit (30" or 48") for your bin.

The stock bin deflector must be removed and replaced with the correct deflector to prevent injury.

⚠ Warning

PERSONAL INJURY POTENTIAL

Do not operate any ice machine with the deflector removed.

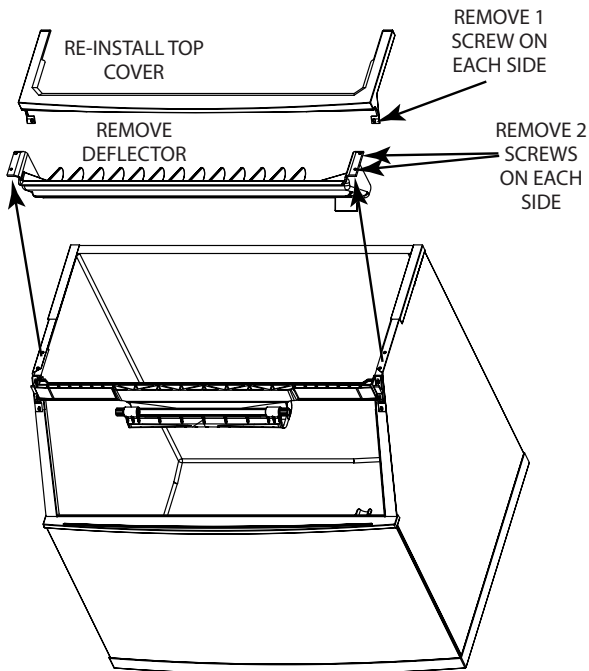

A deflector must be installed on all dual evaporator models used in bin applications

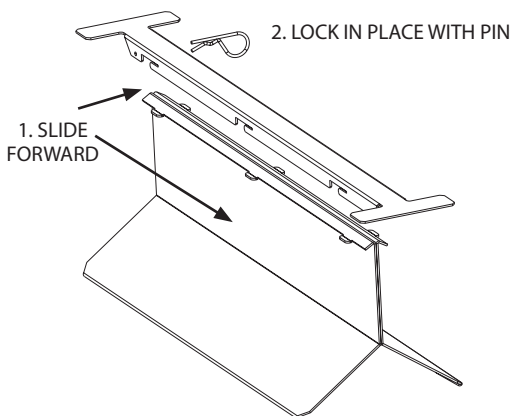

Ice Machine on a Dispenser Installation

No deflector is needed for machines that match the size of the dispenser (30" head section on a 30" dispenser) unless required by the dispenser manufacturer. Adapters are required when a smaller ice machine is going on a larger dispenser (22" machine on a 30" dispenser).

Important

Manitowoc Ice/Beverage Ice Machines require an adapter for mounting. Adapters are not included with the ice machine, dispenser or bin and must be ordered separately. When a non-Manitowoc adapter is used, verify the adapter is compatible with Manitowoc Ice/Beverage Ice Machines prior to installation.

⚠ Warning

Ice Beverage ice machines, adapter plates and adapter covers must be secured to the dispenser to prevent tipping or dislodging during agitation.

Lineset Applications

Caution

The 60-month compressor warranty (including the 36-month labor replacement warranty) will not apply if the Manitowoc Ice Machine, Condenser or QuietQube® Condensing Unit were not installed according to specifications. This warranty also will not apply if the refrigeration system is modified with a condenser, heat reclaim device, or other parts or assemblies not manufactured by Manitowoc Ice.

Warning

Recovery locations vary by model. Verify you are making the correct connections for your model to prevent accidental release of high pressure refrigerant.

Important

Manitowoc remote systems are only approved and warranted as a complete new package. Warranty on the refrigeration system will be void if new equipment is connected to pre-existing (used) tubing, remote condenser, remote condensing unit or ice machine head section.

QuietQube® Remote Condensing Unit

QuietQube® Ice Machine	Remote Single Circuit Condenser	Line Set*
I0670C - I0680C IB0670C - IB0690C	ICVD0695	RC-26 RC-36 RC-56
I0870C - I0890C IB0870C - IB0890C	ICVD0895	
I0970C	ICVD0996	
I1070C	ICVD1095 ICVD1195	
IB1090C	ICVD1195	
I1470C	ICVD1495	
I1870C	ICVD1895	
I2170C	ICVD2095	RC-28 RC-38 RC-58

*Line Set	Suction Line	Liquid Line	Minimum Insulation Thickness
RC 26/36/56	5/8 inch (16 mm)	3/8 inch (10 mm)	1/2" (13 mm) Suction Line 1/4" (7 mm) Liquid Line
RC 25/35/55	3/4 inch (19 mm)	1/2 inch (13 mm)	1/2" (13 mm) Suction Line 1/4" (7 mm) Liquid Line
RC 28/38/58	3/4 inch (19 mm)	5/8 inch (16 mm)	1/2" (13 mm) Suction Line 1/4" (7 mm) Liquid Line

ICVD TRANSFORMER WIRING

ICVD transformers leave the factory wired for a 240V supply voltage. When connecting to a 208V supply voltage, the transformer must be rewired to maintain the proper secondary voltage. Failure to correctly wire the transformer will result in premature component failure. Refer to wiring diagrams for wiring details.

Important

An incorrectly wired transformer will read a secondary voltage of 24 volts, but will not carry enough power (volt amps) to properly energize components. Correctly wired transformers normally measure in the range of 27 to 28 vac. Example - 208V primary wired for 230V will measure 24 vac, but causes overheating and contactor failure.

ICVD INTERCONNECTING WIRING

Important

Indigo QuietQube ice machines require interconnecting low voltage wiring (included with Manitowoc line sets) to energize the contactor coil and verify the LPCO & HPCO are closed. This circuit also initiates a time delay whenever the LPCO or HPCO open. Failure to properly wire the iCVD condensing unit or ice machine head section will result in a non-operational machine.

Wire Specifications:

18 AWG 5 Conductor, Single Strand, Plenum Rated, UL rated to 300 volts.

Additional Refrigerant Charge For 51' to 100' Line Sets

Ice Machine	Condenser	Additional Amount of Refrigerant To Be Added To Nameplate Charge
I0680C IB0690C	ICVD0695	1.5 lbs 680 g
I0686C IB0696C	ICVD0696	
I0870C	ICVD0895	4 lbs 1814 g
IB890C	ICVD0895	2 lbs 907 g
IB0890C I0976C	ICVD0996	4 lbs 1814 g
I1070C	ICVD1095 ICVD1195	2 lbs 907 g
IB1090C IB1096C	ICVD1096	2 lbs 907 g
I1070C IB1094C	ICVD1195	2 lbs 907 g
I1470C	ICVD1495	2 lbs 907 g
I1476C	ICVD1496	2 lbs 907 g
I1870C	ICVD1895	2 lbs 907 g
I2170C	ICVD2095	4 lbs 1814 g
I2176C	ICVD2096	4 lbs 1814 g

Calculating Allowable Lineset Distance

Line Set Length

The maximum length is 100' (30.5 m).

Line Set Rise/Drop

The maximum rise is 35' (10.7 m).

The maximum drop is 15' (4.5 m).

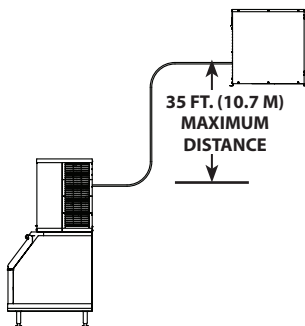

35 ft. (10.7 m) Rise: The maximum distance the Condenser or Condensing Unit can be above the ice machine.

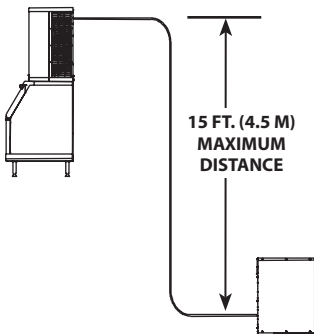

15 ft. (4.5 m) Drop: The maximum distance the Condenser or Condensing Unit can be below the ice machine.

THIS PAGE INTENTIONALLY LEFT BLANK

Maintenance

Cleaning and Sanitizing

GENERAL

You are responsible for maintaining the ice machine in accordance with the instructions in this manual. Maintenance procedures are not covered by the warranty.

Clean and sanitize the ice machine every six months for efficient operation. If the ice machine requires more frequent cleaning and sanitizing, consult a qualified service company to test the water quality and recommend appropriate water treatment. An extremely dirty ice machine must be taken apart for cleaning and sanitizing.

Manitowoc Ice Machine Cleaner and Sanitizer are the only products approved for use in Manitowoc ice machines.

 **Caution**

Use only Manitowoc approved Ice Machine Cleaner and Sanitizer for this application (Manitowoc Cleaner part number 9405463 and Manitowoc Sanitizer part number 9405653). It is a violation of Federal law to use these solutions in a manner inconsistent with their labeling. Read and understand all labels printed on bottles before use.

 **Caution**

Do not mix Cleaner and Sanitizer solutions together. It is a violation of Federal law to use these solutions in a manner inconsistent with their labeling.

 **Warning**

Wear rubber gloves and safety goggles (and/or face shield) when handling Ice Machine Cleaner or Sanitizer.

CLEANING/SANITIZING PROCEDURE

This procedure must be performed a minimum of once every six months.

- The ice machine and bin must be disassembled cleaned and sanitized.
- All ice produced during the cleaning and sanitizing procedures must be discarded.
- Removes mineral deposits from areas or surfaces that are in direct contact with water.

PREVENTATIVE MAINTENANCE CLEANING PROCEDURE

- This procedure cleans all components in the water flow path, and is used to clean the ice machine between the bi-yearly cleaning/sanitizing procedure.

EXTERIOR CLEANING

Clean the area around the ice machine as often as necessary to maintain cleanliness and efficient operation.

Wipe surfaces with a damp cloth rinsed in water to remove dust and dirt from the outside of the ice machine. If a greasy residue persists, use a damp cloth rinsed in a mild dish soap and water solution. Wipe dry with a clean, soft cloth.

The exterior panels have a clear coating that is stain resistant and easy to clean. Products containing abrasives will damage the coating and scratch the panels.

- Never use steel wool or abrasive pads for cleaning.
- Never use chlorinated, citrus based or abrasive cleaners on exterior panels and plastic trim pieces.

Cleaning / Sanitizing Procedure

Caution

Use only Manitowoc approved Ice Machine Cleaner and Sanitizer for this application (Manitowoc Cleaner part number 9405463 and Manitowoc Sanitizer part number 9405653). It is a violation of Federal law to use these solutions in a manner inconsistent with their labeling. Read and understand all labels printed on bottles before use.

CLEANING PROCEDURE

Caution

Do not mix Cleaner and Sanitizer solutions together. It is a violation of Federal law to use these solutions in a manner inconsistent with their labeling.

Warning

Wear rubber gloves and safety goggles (and/or face shield) when handling Ice Machine Cleaner or Sanitizer.

Ice machine cleaner is used to remove lime scale and mineral deposits. Ice machine sanitizer disinfects and removes algae and slime.

NOTE: Although not required and dependent on your installation, removing the ice machine top cover may allow easier access.

Step 1 Open the front door to access the evaporator compartment. Ice must not be on the evaporator during the clean/sanitize cycle. Follow one of the methods below:

- Press the power switch at the end of a harvest cycle after ice falls from the evaporator(s).
- Press the power switch and allow the ice to melt.

 **Caution**

Never use anything to force ice from the evaporator. Damage may result.

Step 2 Remove all ice from the bin/dispenser.

Step 3 Press the clean switch. Water will flow through the water dump valve and down the drain. Wait until the water trough refills and the display indicates add solution (approximately 1 minute), then add the proper amount of ice machine cleaner.

Model	Amount of Cleaner
I0680C - I0686C - IB0696C I0870C - IB0890C - I0976C I1070C - I1176C - IB1090C	5 ounces (150 ml)
I1470C - I1870C - I2170C - I2176C	9 ounces (265 ml)

Step 4 Wait until the clean cycle is complete (approximately 24 minutes). Then disconnect power to the ice machine (and dispenser when used).

⚠ Warning

Disconnect the electric power to the ice machine at the electric service switch box.

Step 5 Remove parts for cleaning.

Please refer to the proper parts removal for your ice machine. Continue with step 6 when the parts have been removed.

“Single Evaporator Ice Machines” on page 44

“Ice Beverage Ice Machines” on page 46

“Dual Evaporator Ice Machines” on page 48

Step 6 Mix a solution of cleaner and lukewarm water. Depending upon the amount of mineral buildup, a larger quantity of solution may be required. Use the ratio in the table below to mix enough solution to thoroughly clean all parts.

Solution Type	Water	Mixed With
Cleaner	1 gal. (4 L)	16 oz (500 ml) cleaner

Step 7 Use 1/2 of the cleaner/water mixture to clean all components. The cleaner solution will foam when it contacts lime scale and mineral deposits; once the foaming stops use a soft-bristle nylon brush, sponge or cloth (NOT a wire brush) to carefully clean the parts. Soak parts for 5 minutes (15 - 20 minutes for heavily scaled parts). Rinse all components with clean water.

Step 8 While components are soaking, use 1/2 of the cleaner/water solution to clean all food zone surfaces of the ice machine and bin (or dispenser). Use a nylon brush or cloth to thoroughly clean the following ice machine areas:

- Side walls
- Base (area above water trough)
- Evaporator plastic parts - including top, bottom, and sides
- Bin or dispenser

Rinse all areas thoroughly with clean water.

SANITIZING PROCEDURE

Step 9 Mix a solution of sanitizer and lukewarm water.

Solution Type	Water	Mixed With
Sanitizer	3 gal. (12 L)	2 oz (60 ml) sanitizer

Step 10 Use 1/2 of the sanitizer/water solution to sanitize all removed components. Use a spray bottle to liberally apply the solution to all surfaces of the removed parts or soak the removed parts in the sanitizer/water solution. Do not rinse parts after sanitizing.

Step 11 Use 1/2 of the sanitizer/water solution to sanitize all food zone surfaces of the ice machine and bin (or dispenser). Use a spray bottle to liberally apply the solution. When sanitizing, pay particular attention to the following areas:

- Side walls
- Base (area above water trough)
- Evaporator plastic parts - including top, bottom and sides
- Bin or dispenser

Do not rinse the sanitized areas.

Step 12 Replace all removed components.

Step 13 Wait 20 minutes.

Step 14 Reapply power to the ice machine and perform the following keystrokes.

- Press the Clean button.
- Press the right arrow button, select clean yes button.
- Press checkmark button.
- Press the right arrow button, select auto start yes button.
- Press checkmark button.

Step 15 Wait until the water trough refills and the display indicates add solution (approximately 1 minute). Add the proper amount of Manitowoc Ice Machine Sanitizer to the water trough by pouring between the water curtain and evaporator.

Model	Amount of Sanitizer
I0680C - I0686C - IB0696C I0870C - IB0890C - I0976C I1070C - I1176C	3 ounces (90 ml)
IB1090C	3.5 ounces (104 ml)
I1470C - I1870C I2170C - I2176C	12 ounces (355 ml)

Step 16 Select Auto Ice On, press the checkmark and close and secure the front door. The ice machine will automatically start ice making after the sanitize cycle is complete (approximately 24 minutes).

PARTS REMOVAL FOR CLEANING/SANITIZING

Single Evaporator Ice Machines

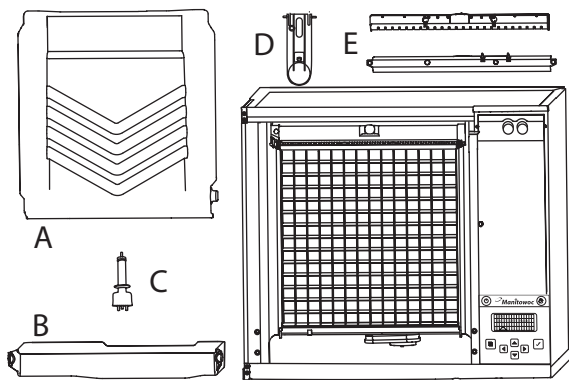

A. Remove the water curtain

- Gently flex the curtain in the center and remove it from the right side.
- Slide the left pin out.

B. Remove the water trough

- Depress tabs on right and left side of the water trough.
- Allow front of water trough to drop as you pull forward to disengage the rear pins.

C. Remove the water level probe

- Pull the water level probe straight down to disengage.
- Lower the water level probe until the wiring connector is visible.
- Disconnect the wire lead from the water level probe.
- Remove the water level probe from the ice machine.

D. Remove the ice thickness probe

- Compress the hinge pin on the top of the ice thickness probe.
- Pivot the ice thickness probe to disengage one pin then the other. The ice thickness probe can be cleaned at this point without complete removal. If complete removal is desired, disconnect the ice thickness control wiring from the control board.

E. Remove the water distribution tube

NOTE: Distribution tube thumbscrews are retained to prevent loss. Loosen thumbscrews but do not pull thumbscrews out of distribution tube.

- Loosen the two outer screws (do not remove screws completely they are retained to prevent loss) and pull forward on the distribution tube to release from slip joint.
- Disassemble distribution tube by loosening the two (2) middle thumbscrews and dividing the distribution tube into two pieces.

NOTE: Proceed to step 6 on page 40.

Ice Beverage Ice Machines

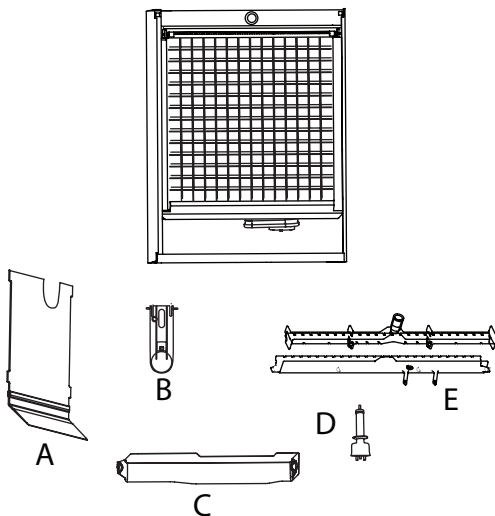

A. Remove splash shield

- Grasp the top center of splash shields.
- Lift up and then out.

B. Remove ice thickness probe

- Compress the hinge pin on the top of the ice thickness probe.
- Pivot the ice thickness probe to disengage one pin then the other. The ice thickness probe can be cleaned at this point without complete removal. If complete removal is desired, disconnect the ice thickness control wiring from the control board.

C. Remove the water trough

- Depress tabs on right and left side of the water trough.
- Allow front of water trough to drop as you pull forward to disengage the rear pins.

D. Remove the water level probe

- Pull the water level probe straight down to disengage.
- Lower the water level probe until the wiring connector is visible.
- Disconnect the wire lead from the water level probe.
- Remove the water level probe from the ice machine.

E. Remove the water distribution tube

NOTE: Distribution tube thumbscrews are retained to prevent loss. Loosen thumbscrews but do not pull thumbscrews out of distribution tube.

- Loosen the two outer screws (do not remove screws completely they are retained to prevent loss) and pull forward on the distribution tube to release from slip joint.
- Disassemble distribution tube by loosening the two (2) middle thumbscrews and dividing the distribution tube into two pieces

NOTE: Proceed to step 6 on page 40.

Dual Evaporator Ice Machines

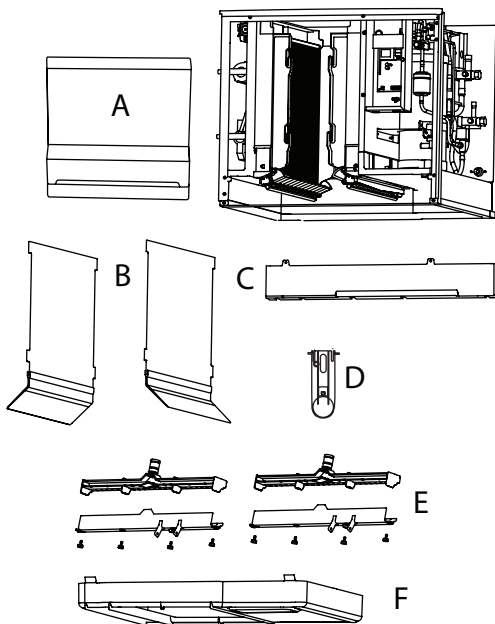

A. Remove front splash shield

- Grasp the top of the splash shield.
- Lift up and then out.

B. Remove evaporator splash shields

- Grasp the top center of splash shields.
- Lift up and then out.

C. Remove the water trough shield

- Grasp the water trough shield in the center and the left end.
- Flex the water trough shield in the center and pull the left end forward until clear of the side wall. Repeat for the right end.
- Pull water trough shield forward to remove.

D. Remove ice thickness probe

- Compress the hinge pin on the top of the ice thickness probe.
- Pivot the ice thickness probe to disengage one pin then the other. The ice thickness probe can be cleaned at this point without complete removal. If complete removal is desired, disconnect the ice thickness control wiring from the control board.

E. Remove ice dampers

- Grasp ice damper and apply pressure toward the back mounting bracket.
- Apply pressure to the front mounting bracket with thumb.
- Pull ice damper down when the front ice damper pin disengages.

F. Remove the water pump assembly

- Disconnect the vinyl distribution tube from the water pump.
- Disconnect the water pump and water level probe electrical connections.
- After the wires are disconnected, remove the two thumbscrews and lift the water pump assembly out of the ice machine.
- Remove the thumbscrews securing the water pumps (2 each pump) and remove water pumps. Do not immerse the water pump motor in cleaner or sanitizer solutions.
- Remove the water level probe from the assembly housing.

G. Remove distribution tubes

- Distribution tubes thumbscrews are retained to prevent loss. Loosen thumbscrews but do not pull thumbscrews out of distribution tube.
- Loosen the two outer screws and pull forward on the distribution tube to release from slip joint.

- Disassemble distribution tube by loosening the two (2) middle thumbscrews and dividing the distribution tube into two pieces.

H. Remove the water trough

- Depress the two tabs on the top of the water trough.
- Turn left and right ice dampers down to clear water trough.
- Pull forward on the water trough to remove.

NOTE: Proceed to page 40 Step 6.

Ice Thickness Probe & Water Level Probe

Clean the probes using the following procedure.

1. Mix a solution of Manitowoc ice machine cleaner and water (2 ounces of cleaner to 16 ounces of water) in a container.
2. Soak probes in container of cleaner/water solution while disassembling and cleaning water circuit components (soak probes for 10 minutes or longer).
3. Clean all probe surfaces including all plastic parts (do not use abrasives). Verify all surfaces are clean. Thoroughly rinse probes with clean water.
4. Reinstall probe, then sanitize the ice machine and bin/dispenser interior surfaces.

Water Inlet Valve

The water inlet valve normally does not require removal for cleaning. Refer to "Water System Checklist" page 134, if you are troubleshooting water related problems.

1. When the ice machine is off, the water inlet valve must completely stop water flow into the machine. Watch for water flow.

When the ice machine is on, the water inlet valve must allow the proper water flow through it. Press the Power button to energize the ice machine. Watch for water flow into the ice machine. If the water flow is slow or only trickles into the ice machine, refer to water system checklist.

Water Dump Valve

The water dump valve normally does not require removal for cleaning. To determine if removal is necessary:

1. Locate the water dump valve.
2. Press the power button and stop ice making.
3. While the ice machine is in the freeze mode, check the water trough to determine if the dump valve is leaking. If there is no or little water in the water trough (during the freeze cycle) the dump valve is leaking.
 - A. If the dump valve is leaking, remove, disassemble and clean it.
 - B. If the dump valve is not leaking, do not remove it. Instead, follow the "Ice Machine Cleaning Procedure".

Removal from Service/Winterization

General

Special precautions must be taken if the ice machine is to be removed from service for an extended period of time or exposed to ambient temperatures of 32°F (0°C) or below.

Caution

If water is allowed to remain in the ice machine in freezing temperatures, severe damage to some components could result. Damage of this nature is not covered by the warranty.

Follow the applicable procedure below.

AIR-COOLED ICE MACHINES

1. Press the power button.
2. Turn off the water supply.
3. Remove the water from the water trough.
4. Disconnect and drain the incoming ice-making water line at the rear of the ice machine.
5. Energize the ice machine and wait one minute for the water inlet valve to open.
6. Blow compressed air in both the incoming water and the drain openings in the rear of the ice machine until no more water comes out of the water inlet lines or the drain.
7. Disconnect the electric power at the circuit breaker or the electric service switch.
8. Make sure water is not trapped in any of the water lines, drain lines, distribution tubes, etc.

THIS PAGE INTENTIONALLY LEFT BLANK

Operation

Power Button

Cleaning Button

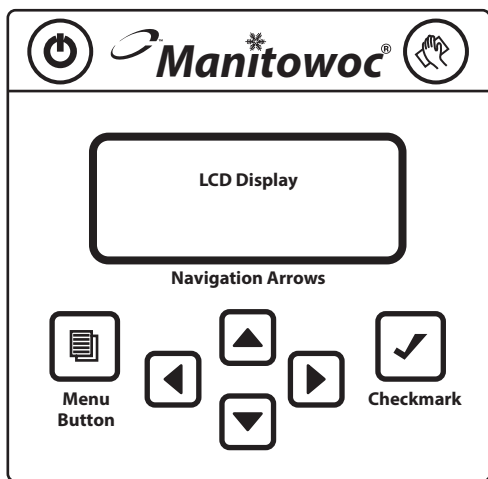

Control Panel Features

The control panel offers a series of pressure sensitive buttons and a four-line interactive display panel.

BUTTONS

Power Button: Powers the ice machine when in the On/Off Mode. The ice machine can also be programmed to automatically power on and off in two Energy Saver modes.

Cleaning Button: Initiates a cleaning cycle. Refer to the *Maintenance* section for details.

Menu Button: Accesses main menu structure. Moves the display from the Home Screen, where ice machine status, alerts and messages are viewed, to the Main Menu, where machine information and its event log can be accessed, machine and Energy Saver settings can be adjusted, and service issues can be addressed.

Left and Right Arrows: The Left arrow moves the display to the previous screen, allowing the user to “back out” of programming. Both the Left and Right arrows will move the cursor (underline) within a line of settings. NOTE: The Right arrow can also be used on many screens interchangeably with the checkmark to make a selection.

Up and Down Arrows: Move the highlight [brackets] up one line or down one line.

Checkmark: Makes a selection and/or moves to the next screen (or line) and is used like an “enter” button.

DISPLAY PANEL

The LCD display panel is 16 characters wide and four lines deep. During ice machine operation and cleaning cycles, the Home screen’s top three lines provide valuable status information and the fourth line shows alerts and messages. In programming, four lines of the current screen are displayed and highlights, arrows, cursor and selections inform the user of available actions.

Menu Navigation Overview

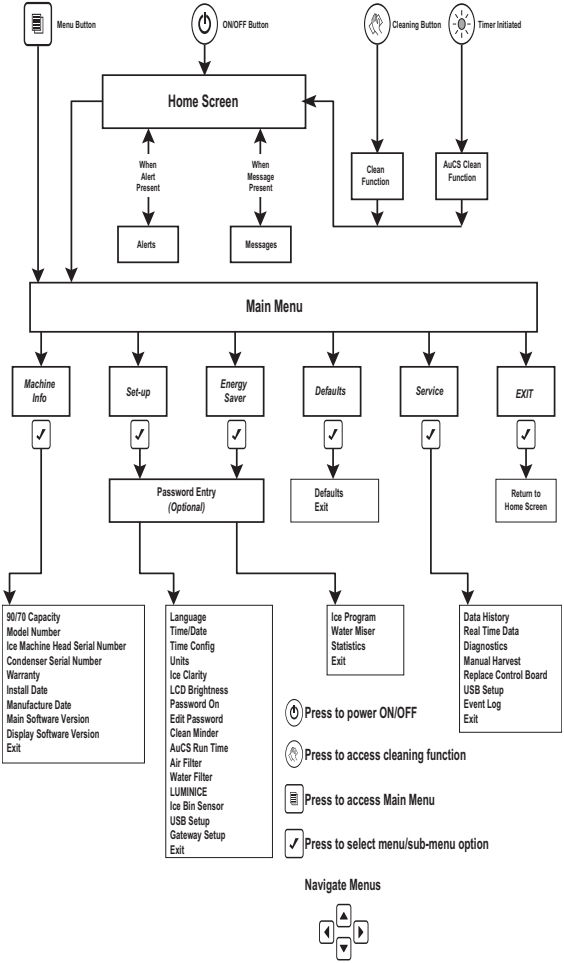

NOTE: The ice machine will automatically set the installation date after 100 freeze/harvest cycles.

Display Panel Navigation

[T	i	m	e	&	D	a	t	e	>]	▼
	T	i	m	e	C	o	n	f	i	g	>	
	U	n	i	t	s					>		▼

Highlights: Brackets indicate if a line on the screen is “highlighted” or actionable. Move the brackets from line to line using the Down or Up arrow. Move the brackets down from the fourth line to view more of the menu displayed.

Arrows: Two kinds of arrows give cues to additional information. “>” symbols show that another screen is available by pressing Checkmark or > while a line is highlighted. “▼” and “▲” symbols indicate the limits of the screen viewed. NOTE: Another cue to the length of a menu screen is that Exit is the last item.

	0	7		2	4		1	0									
	1	4	:	0	8												
	E	x	i	t													>

Cursor: A cursor (underline) is used within lines where actual settings can be adjusted. In these screens, use the Up and Down arrows to make changes to the value underlined. Move the cursor from digit to digit using the Right and Left arrows. Use the Checkmark to move the cursor down one line. Exit and re-enter the screen to start again at the top.

[M	o	/	D	a	y	/	Y	r		(✓)]	▼
	D	a	y	/	M	o	/	Y	r		()		
	1	2		H	o	u	r				()		
	2	4		H	o	u	r				(✓)		▼

Selections: When parentheses () appear, they indicate a selection is available by pressing Checkmark while the line is highlighted. If the choice is exclusive, selecting it with the Checkmark will uncheck another selection. That is, in the above Time Config example, selecting Day/Mo/Yr will deselect Mo/Day/Yr.

Alerts and Messages

When messages and alerts exist, they will be highlighted and can be selected with the Left arrow. Alerts are conditions that may cause the ice machine to stop in the near future. Alerts displayed will have priority over messages.

Messages are shown on the right side and appear as an envelope - They are reminders such as clean your air condenser filter, change your water filter, etc.

	O	f	f																
	O	n	/	O	f	f	M	o	d	e									
[]

For example, if alerts are appearing in the fourth line of the display:

1. Press Checkmark. A list of alerts will appear in the display.
2. Choose the alert you wish to address by moving the highlight brackets with the Down arrow.
3. Press Checkmark again. A screen appears with a line that can be selected for clearing the alert, a line for accessing a list of possible causes and a line for accessing service information.
4. Return to the Home screen by pressing the Left arrow until it appears.

Main Menu

From the Home screen, press the Menu button to enter the Main menu, where you can choose to see machine information, make setup changes, set the Energy Saver mode, or enter the Service Menu.

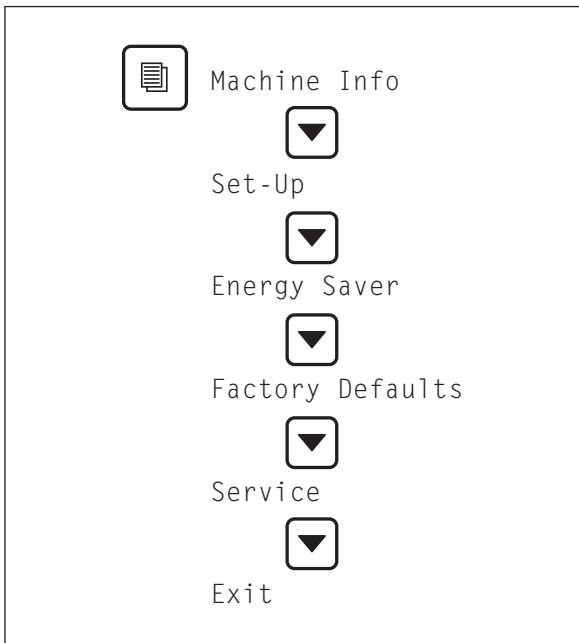

Main Menu

Machine Info Menu

From the Main menu, ensure that Machine Info is highlighted and press the Checkmark to view a list including capacity, model number, IMH (Ice Machine Head) serial number, condenser serial number, warranty, installation date, date of manufacture and software version. Use the Down arrow to highlight an item and use the Checkmark to view the information. Press the Left arrow to return to previous screens.

Machine Info Menu

- 90/70 capacity
- Model # (Do not add numbers after model and voltage; Either 161, 261, 263 will end the model number entry).
- Ice Machine Head Serial #
- Condenser Serial #
- Warranty
 - Machine
 - Evaporator
 - Compressor
- Install Date
- Manufacture Date
- Main Control Board Software Version
- Display Software Version

Password Entry

A password is not required, although a password can be turned on to prevent unauthorized control setting modification. You can use the Factory Default Password of "1234" or enter a four digit custom pin number of your choosing.

To turn on the password feature use the following procedure.

1. Press the Menu button.
2. From the Main menu, use the Down arrow to highlight setup and press the Right arrow.
3. Use the Down arrow to highlight Password ON and press the Right arrow.
4. Press the Right arrow again with Enter Passwrđ highlighted and a cursor will flash.
5. Use the Up & Down arrows to enter the factory password (1, 2, 3, 4). Enter the number 1 in the flashing cursor (first digit of the factory password).
6. Press the right arrow to move to the next cell and use the Up & Down arrows to add the number 2. Repeat this process to add 3 & 4.
7. When the last number is entered press the Checkmark button to save your entry.

	E	n	t	e	r		P	a	s	s	w	r	d		▲
[]
	E	x	i	t										>	

To enter a four digit password of your choosing use the following procedure.

1. Press the Menu button.
2. From the Main menu, use the Down arrow to highlight setup and press the Right arrow.
3. Use the Down arrow to select Edit Password and press the Right arrow.
4. Using the Up & Down arrows, enter the first digit of the factory password in the flashing icon.
5. Press the right arrow to move to the next cell and use the Up & Down arrows to add the number 2. Repeat this process to add 3 & 4.
6. When the last number is entered press the Checkmark button.
7. Follow steps 4 & 5 and enter your 4 digit password.
8. When the last number is entered press the Checkmark button to save your entry.

RESET PASSWORD TO FACTORY DEFAULTS

The password can be reset to the factory defaults when required. The default factory password is 1234.

The entire setup can be reset to the factory defaults.

1. Press the Menu button.
2. From the Main menu, use the Down arrow to highlight Fact Deflts.
3. Press the Checkmark two times to reset the ice machine. The display will return to the Set-Up menu and the defaults listed below will be in effect. Refer to Set-Up Menu to adjust settings..

Setting	Default
Language	English
Time & Date	Central Time Zone
Time Configuration	Mo/Day/Yr/24 Hour
Units	Fahrenheit/Lbs/Gallons
Ice Clarity	Off
LCD Brightness	Level 2
Password On/Off	Off
Clean Minder	Off
AuCS RunTime	Off
Air Filter	Off
Water Filter	Auto
LuminIce® Replace Bulb	No
Ice Bin Sensor	Off

Set-Up Menu

From the Main menu, use the Down arrow to navigate to Set-Up and press the Checkmark. Select and customize machine settings on this menu. Press the Left arrow to return to previous screens.

- Set-Up
- Language
- Time & Date
- Time Configuration
- Units
- Ice Clarity
- LCD Bright
- Password On
- Edit Password
- Clean Minder
- AuCS RunTime
- Air Filter
- Water Filter
- LUMINICE
- Ice Bin Sensor
- USB Setup
- Exit

Set-Up Menu

LANGUAGE

1. From the Set-Up menu, use the Down arrow to highlight Language.
2. Press the Checkmark. You can choose to view the display in a language other than English, by highlighting your choice and pressing the Checkmark. Selecting one language will deselect the others.
3. When the check reflects your preference, use the Down arrow to navigate to Exit and press the Checkmark. The display will return to the Set-Up menu.

TIME & DATE

When the ice machine is installed, the correct time and date needs to be set for its location.

[M	o	/	D	a	y	/	Y	r		(✓)]	▼
	D	a	y	/	M	o	/	Y	r		()		
	1	2		H	o	u	r				()		
	2	4		H	o	u	r				(✓)		▼

Time Configuration

1. From the Set-Up menu, use the Down arrow to highlight Time Config.
2. Press the Checkmark. On this screen, you can choose whether the date will be displayed as Mo/Day/Yr or Day/Mo/Yr by highlighting your choice and pressing the Checkmark. Selecting one will deselect the other.
3. You can also choose whether the time will be displayed as 12 Hour or 24 Hour by highlighting your choice and pressing the Checkmark. Selecting one will deselect the other.
4. When the two checks reflect your preference, use the Down arrow to navigate to Exit and press the Checkmark. The display will return to the Set-Up menu.

UNITS

1. From the Set-Up menu, use the Down arrow to highlight Units.
2. Press the Checkmark. On this screen, you can choose whether the ice machine will display measurements in Celsius or Fahrenheit, kilograms or pounds, and gallons or liters by highlighting your choice of each pair and pressing the Checkmark. Selecting one of each pair will deselect the other. Make sure to navigate with the Down arrow to make all three choices.
3. When the three checks reflect your preferences, use the Down arrow to navigate to Exit and press the Checkmark. The display will return to the Set-Up menu.

ICE CLARITY

In areas with poor potable water quality, the ice machine may produce cloudier ice. Setting Ice Clarity to ON will add additional water during the freeze cycle to dilute the water that contains a high content of dissolved solids in the water trough. This feature decreases production and increases water usage. A water filter is recommended to produce the highest quality ice while maintaining the least expensive mode of operation.

1. From the Set-Up menu, use the Down arrow to highlight Ice Clarity.
2. Press the Checkmark. On this screen, you can choose to turn the ice clarity feature ON or OFF by highlighting your choice and pressing the Checkmark. Selecting one will deselect the other.
3. When the check reflects your preference, use the Down arrow to navigate to Exit and press the Checkmark. The display will return to the Set-Up menu.

LCD BRIGHTNESS

Here, the brightness of the LCD display can be adjusted.

1. From the Set-Up menu, use the Down arrow to highlight LCD Bright.
2. Press the Checkmark. You will see one of four checkmarks indicating the brightness levels of the display. Level 1 is one checkmark, level 2 is two checkmarks, Level 3 is three checkmarks, etc.
3. Use the Up and Down arrows to select your preference.
4. When the checkmarks reflect your preference, press the Checkmark. The display will return to the Set-Up menu.

PASSWORD ON

A password can be added to prevent unauthorized changes to ice machine settings.

1. From the Set-Up menu, use the Down arrow to highlight Password On.
2. Enter the password and press the Checkmark.
3. Press the Left arrow to return to previous screens and to the Set-Up menu.

EDIT PASSWORD

The password can be changed on this screen.

1. From the Set-Up menu, use the Down arrow to highlight Edit Password.
2. Press the Checkmark and confirm current password.
3. Enter new password and press the Checkmark.
4. Press the Left arrow to return to previous screens and to the Set-Up menu.

CLEAN MINDER

Clean Minder is a feature that displays a cleaning reminder at a set time interval.

1. From the Set-Up menu, use the Down arrow to highlight Clean Minder.
2. Press the Checkmark. On this screen, you can choose to turn the reminder ON or OFF by highlighting your choice and pressing the Checkmark. Selecting one will deselect the other.
3. You can also choose the time interval from this screen by highlighting Set Interval and pressing the Checkmark.
4. Press the Left arrow to return to previous screens and to the Set-Up menu.

IAUCS RUNTIME

Automatic Cleaning System is an optional accessory and will perform a cleaning cycle at a set time interval.

1. From the Set-Up menu, use the Down arrow to highlight AuCS RunTime.
2. Press the Checkmark. On this screen, you can choose to turn the feature ON or OFF by highlighting your choice and pressing the Checkmark. Selecting one will deselect the other.
3. You can also choose the time interval from this screen by highlighting Set Interval and pressing the Checkmark.
4. Press the Left arrow to return to previous screens and to the Set-Up menu.

AIR FILTER

The ice machine has a feature that displays a clean air filter reminder at a set time interval.

1. From the Set-Up menu, use the Down arrow to highlight Air Filter.
2. Press the Checkmark. On this screen, you can choose to turn the reminder to AUTO or OFF by highlighting your choice and pressing the Checkmark. Selecting one will deselect the other.
3. You can also choose the time interval from this screen by highlighting Set Interval and pressing the Checkmark.
4. Press the Left arrow to return to previous screens and to the Set-Up menu.

WATER FILTER

The ice machine has a feature that displays a replace water filter reminder at a set time interval.

1. From the Set-Up menu, use the Down arrow to highlight Water Filter.
2. Press the Checkmark. You can record the filter type on this screen by highlighting Filter Type and pressing the Checkmark.
3. After making your selection, press the Left arrow to return to the previous screen.
4. On this screen, you can also choose to turn the reminder to AUTO or OFF by highlighting your choice and pressing the Checkmark. Selecting one will deselect the other.
5. You can further choose the time interval from this screen by highlighting Set Interval and pressing the Checkmark.
6. Press the Left arrow to return to previous screens and to the Set-Up menu.

LUMINICE® REMINDER

The LuminIce® growth inhibitor recirculates the air in the ice machine foodzone over a UV bulb. This process will inhibit the growth of common micro-organisms on all exposed foodzone surfaces.

The Bulb Minder is a feature that displays a reminder to change its bulb every 12 months.

1. From the Set-Up menu, use the Down arrow to highlight LuminIce® Minder.
2. Press the Checkmark. On this screen, you can choose to turn the reminder to AUTO or OFF by highlighting your choice and pressing the Checkmark. Selecting one will deselect the other.
3. When the check reflects your preference, use the Down arrow to navigate to Exit and press the Checkmark. The display will return to the Set-Up menu.

ICE BIN LEVEL SENSOR

Ice bin sensor is an optional accessory that allows the ice level in the bin to be set to one of three different levels. The bin level can be set seasonally to match usage, which results in lower energy costs and fresher ice.

1. In the Energy Saver menu, ensure that Ice Program is highlighted and press checkmark.
2. Select Bin Level and press checkmark.
3. Select Settings and press checkmark.
4. On this screen you can choose to set the ice level to low, medium or high by highlighting your choice and pressing the Checkmark. Selecting one will deselect the other.

NOTE: On ice beverage models you must choose low for the control to function. The ice beverage sensor has one thermistor, while the bin level sensor has three.

5. Select - Exit, Save changes, Yes and then Done.

When the check reflects your preference, use Down to navigate to Exit and press the Checkmark. The display will return to the Set-up menu.

USB Setup

Refer to “Upgrading Firmware with a Flash Drive” and “Exporting Data to a Flash Drive” for more information on this setting.

FACTORY DEFAULTS

The entire setup can be reset to factory defaults listed on page page 65

1. From the Set-Up menu, use the Down arrow to highlight Fact Default.
2. Press the Checkmark two times to reset the ice machine. The display will return to the Set-Up menu.

Energy Saver Menu

From the Main menu, use the Down arrow to navigate to Energy Saver and press the Checkmark. Set up an energy saving ice program, enable the Water Miser and view usage statistics from this menu. Press the Left arrow to return to previous screens.

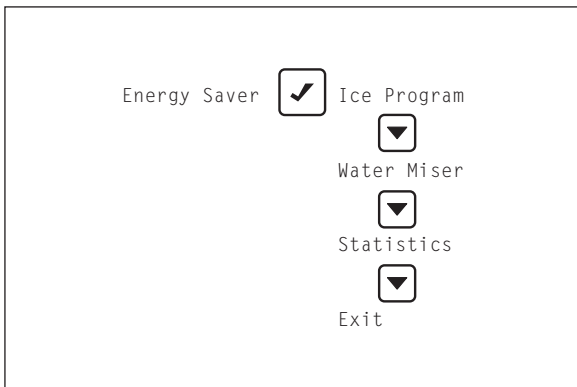

Energy Saver Menu

ICE PROGRAM

To save energy and water, the ice machine can be programmed to only power up during time periods that the ice will be used or when the bin level is being depleted by heavy use.

NOTE: Setting an ice program will take the ice machine out of the On/Off Mode and the Power button will be disabled.

1. In the Energy Saver menu, ensure that Ice Program is highlighted.
2. Press the Checkmark. On this screen, you can choose to turn on the time program or the bin level program by highlighting your choice and pressing the Checkmark. Selecting one will deselect the other. If one of them is selected and you wish to turn both off, highlight the choice and press Checkmark again.
3. If neither of the programs is selected, highlighting Next and pressing the Checkmark will simply return to the top of this screen. If one of the programs is selected, highlight Next and press the Checkmark to choose the times or bin levels. NOTE: For details on how to use the cursor for the time program, refer to "Display Panel Navigation" in this section.
4. Select Exit to return to previous screens and again to the Energy Saver menu.

ICE BIN LEVEL SENSOR

Ice bin sensor is an optional accessory that allows the ice level in the bin to be set to one of three different levels. The bin level can be set seasonally to match usage, which results in lower energy costs and fresher ice.

1. In the Energy Saver menu, ensure that Ice Program is highlighted and press checkmark.
2. Select Bin Level and press checkmark.
3. Select Settings and press checkmark.
4. On this screen you can choose to set the ice level to low, medium or high by highlighting your choice and pressing the Checkmark. Selecting one will deselect the other.

NOTE: On ice beverage models you must choose low for the control to function. The ice beverage sensor has one thermistor, while the bin level sensor has three.

5. Select - Exit, Save changes, Yes and then Done. When the check reflects your preference, use the Down to navigate to Exit and press the Checkmark. The display will return to the Set-up menu.

USB SETUP

Refer to “Upgrading Firmware with a Flash Drive” and “Exporting Data to a Flash Drive” for more information on this setting. Flash drives must be correctly sized and formatted - 2 gigabytes or smaller, Fat 32 file system, 512 allocation units - Refer to page 95 for full specification and formatting details.

WATER MISER

Water Miser is a feature that depending on water quality can reduce water usage by eliminating flush cycles.

1. From the Energy Saver menu, use the Down arrow to highlight Water Miser.
2. Press the Checkmark. On this screen, you can choose to turn the Water Miser ON or OFF by highlighting your choice and pressing the Checkmark. Selecting one will deselect the other.
3. Press the Left arrow to return to previous screens and to the Energy Saver menu.

STATISTICS

1. From the Energy Saver menu, use the Down arrow to highlight Statistics.
2. Press the Checkmark. Choose to view ice usage, or potable water and energy statistics by highlighting your choice and pressing the Checkmark.
3. Press the Left arrow to return to previous screens and to the Energy Saver menu.

Service Menu

From the Main menu, use the Down arrow to navigate to Service and press the Checkmark. This menu is intended for the use of trained service personnel. Below is an overview of the service menu. The following pages list the navigation options available by drilling into the menus with the Right arrow.

Service	<input checked="" type="checkbox"/>	Data History	<input checked="" type="checkbox"/>	00000000 00000000 00000000 00000000 00000000 00000000 Lifetime Exit
		<input type="checkbox"/>		
		RealTime Data	<input checked="" type="checkbox"/>	Time & Temp Inputs Outputs Exit
		<input type="checkbox"/>		
		Diagnostics	<input checked="" type="checkbox"/>	Control Board Temp Sensors Inputs Exit
		<input type="checkbox"/>		
		Man Harvest	<input checked="" type="checkbox"/>	Hrvst Started Exit
		<input type="checkbox"/>		
		Repl Cntl Bd	<input checked="" type="checkbox"/>	Manual Setup USB Setup Exit
		<input type="checkbox"/>		
		USB Setup	<input checked="" type="checkbox"/>	USB Stick Exit
		<input type="checkbox"/>		
		Event Log	<input checked="" type="checkbox"/>	View ELog Clear ELog Exit
		<input type="checkbox"/>		
		Exit		

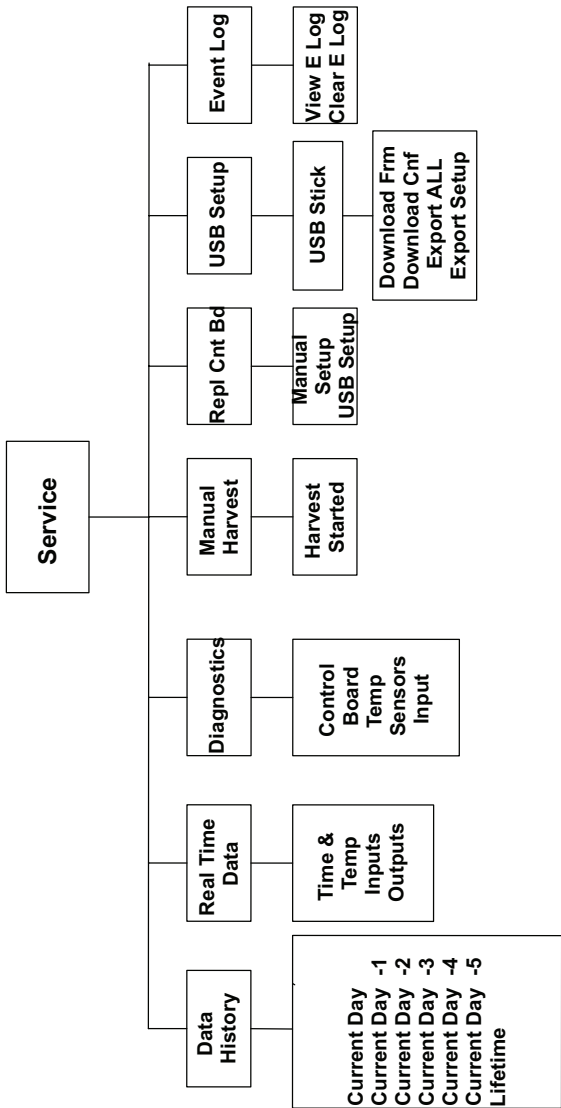

DATA HISTORY

Press the Checkmark with Data History highlighted to view a list of eight-digit dates (Current, Current + 1 ... Current + 5), along with Lifetime (be sure to use the Down arrow to reveal all the available information).

For each of the dates, use the Checkmark to view:

- Minimum Freeze Cycle
- Maximum Freeze Cycle
- Minimum Harvest Cycle
- Maximum Harvest Cycle
- Maximum Temperature Delta T3 - T4
- Delta
- T3
- T4
- Run Time
- Ice Production
- Cycle Count
- Potable Water Usage
- Clean Cycles
- Exit

For Lifetime, use the Checkmark to view:

- Install Date (Install)
- Control Board Replacement Date
- Control Board DOM (Date Of Manufacture)
- RunTime
- Cycle Count
- Potable Water Usage
- Clean Cycles
- Exit

REAL TIME DATA

Press the Checkmark with Real Time Data highlighted to get readings on Time & Temp, Inputs and Outputs (be sure to use the Down arrow to reveal all the available information).

Use the Checkmark to view:

Time and Temperature

- Status Off/On - Displays stage of cycle
- Time
- T1 Thermistor Temperature
- T2 Thermistor Temperature
- T3 Thermistor Temperature
- T4 Thermistor Temperature
- T3 & T4 Delta Temperature
- 100 hz
- 120 hz
- Exit

Inputs

- Status Off/On - Displays stage of cycle
- Curtain Switch 1
- Curtain Switch 2
- LPCO Switch
- HPCO Switch
- Bin Level - Low (Optional Bin Level Probe) Status
- Bin Level - Medium (Optional Bin Level Probe) Status
- Bin Level High (Optional Bin Level Probe) Status
- Sensing Ice No/Yes
- Water Level Low No/Yes
- Water Level High No/Yes
- Exit

Outputs

- Status Off/On - Displays stage of cycle
- Water Pump Off/On
- Hot Gas Valve 1 Off/On
- Hot Gas Valve 2 Off/On
- Air Pump Off/On
- Water Valve Off/On
- Dump Valve Off/On
- Compressor Control Off/On
- AuCS Relay Off/On
- Ionic Cln Off/On
- Exit

DIAGNOSTICS

Press the Checkmark with Diagnostics highlighted to enter screens where you can run diagnostics on the control board, sensors and switches.

Control Board

- Self Check
- Enable Relays
- Exit

Temperature Sensors

- T1 Thermistor Temperature
- T2 Thermistor Temperature
- T3 Thermistor Temperature
- T4 Thermistor Temperature
- Exit

Inputs

- Curtain Switch 1 Closed/Open
- Curtain Switch 2 Closed/Open
- LPCO Switch Closed/Open
- HPCO Switch Closed/Open
- Bin Level - Low (Optional Bin Level Probe) Closed/Open
- Bin Level - Medium (Optional Bin Level Probe) Closed/Open
- Bin Level - High (Optional Bin Level Probe) Closed/Open
- Sensing Ice No/Yes
- Water Level Low No/Yes
- Water Level High No/Yes
- Exit

MANUAL HARVEST

Press the Checkmark with Manual Harvest highlighted to initiate a manual harvest.

- Manual Harvest
- Harvest Started
- Exit

REPLACE CONTROL BOARD

Press the Checkmark with Replace Control Board highlighted to program the replacement control board. The data can be copied from the defective control board (refer to “Exporting Data to a Flash Drive” on page 99), or entered manually through the Indigo interface.

- Manual Setup
 - Board Install Date
 - Input Model Number

NOTE: Do not add numbers after model and voltage; Either 161, 261, 263 is the end of the model number entry.

- Input Serial Number
- Condenser/condensing unit serial number
- USB Setup
 - Insert Drive
 - Press Checkmark and wait for completion
- Exit

USB SETUP

- USB Stick
 - Download Firmware
Insert drive and wait for completion
 - Download Configuration
Insert drive and wait for completion
 - Export All
Insert drive and wait for completion
 - Export Setup
Insert drive and wait for completion
- Exit

EVENT LOG MENU

From the Service menu, use the Down arrow to navigate to Event Log and press the Checkmark.

Ensure View ELog is highlighted and press the Checkmark to see the first event code, when it occurred and how many times. Use the Down arrow to view information on subsequent event codes. For more information on event codes, see "Service Menu". Use the Left arrow to return to the Event Log menu.

To clear the event log: In the Event Log Menu, use the Down arrow to highlight Clear ELog and press the Checkmark. Press the Left arrow to return to previous screens.

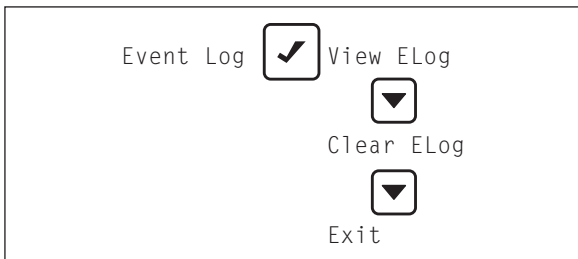

Event Log Menu

EVENT LOG

Refer to the following table for Event Code descriptions.

Code	Description
E01	Long Freeze Cycle
E02	Long Harvest Cycle
E03	Input Power Loss
E04	High Condenser Temperature
E05	High Pressure Control Opened
E06	Spare
E07	Starving TXV Single Evaporator or Low On Charge
E08	TXV Fault Single or Dual Circuit Evaporators
E09	Flooding Evaporator Fault Single Evaporator, Single Circuit
E10	Flooding Evaporator Fault Dual TXV, Dual Circuit
E11	Refrigeration Fault
E12	Curtain Switch Fault - E Board = Open more than 12 hours, G Board after Revision 4.017 = Open more than 24 hours
E13	Spare
E14	Spare
E15	Fan Cycle Control Fault - Lo Liquid Line Temperature
E16	Remote Condensing Unit Fault (ICVD Only)
E17	Spare
E18	Spare
E19	Ice Thickness Probe Fault

Code	Description
E20	Water System Fault
E21	T1 Temperature Sensor Issue
E22	T2 Temperature Sensor Issue
E23	T3 Temperature Sensor Issue
E24	T4 Temperature Sensor Issue
E25	Bin Level Probe Low Sensor Fault
E26	Bin Level Probe Medium Sensor Fault
E27	Bin Level Probe High Sensor Fault
E28	AuCS
E29	USB Communication Fault
E30	USB Download Fault
E31	Safe Mode
E32	RS485 Communication Fault
E33	Keyboard Fault
E34	Display Fault
E36	Check Sum Error
E37	Watch Dog
E38	UI Comm

Event Log Detail

Detail Event Log Service Definition		
E-Log	Display Text	Error Description
E01	Long Freeze	Long Freeze
E02	Long Harvest	Long Harvest
E03	Power Loss	Power Supply (Event Log only - No Alert)
E04	Hi Cnd Temp or Wtr Cnd Fault	Air Condenser High temp, or water Condenser High temperature G Board Rev 4.017 - Alert only after 10 consecutive trips
E05	HPC Fault	High Pressure Cutout (HPC)
E06		Spare
E07	Starving TXV	Starving Evaporator for single TXV or low on charge G Board Rev 4.017 - Event Log only no alert
E08	TXV Fault	Air/Water Only TXV malfunction in dual circuit/ single evaps (TXV Fault)
E09	Flood Evap 1	Flooding evaporator for single circuit single evaporator (flooding evap)
E10	Flood Evap 2	Flooding evaporator for dual TXV dual circuit / single evaporator (Flooding Evap)
		Definition
		6 consecutive 60 Minute Freeze cycles = shut down and flash the SL#1 light on board
		3 consecutive - 3.5 Minute Harvests logs SL#2 in memory, but runs until 500 long harvest cycles occur.
		When power is interrupted to the ice machine the control board will log the event in the ELOG and stamp the loss of power on power-up.
		1). Liquid Line Temperature too High for Self-contained Air Cooled Ice machine = Air Cooled Condenser Fault
		2). Liquid Line Temperature too High for Self-contained Water Cooled ice machine = Water Cooled Condenser Fault
		The high pressure cutout switch (HPCO) opened 3 times in 4 hour period
		10 consecutive occurrences where the Difference of the Average evaporator inlet (T3) and outlet (T4) is greater than 12°F in the last 1 minute of the freeze cycle (ELOG-E07)
		10 consecutive occurrences where the Difference of the Average evaporator inlet (T3) and outlet (T4) is greater than 12°F in the last 1 minute of the freeze cycle (ELOG-E07)
		Average compressor discharge line temperature last 6 seconds of Prechill +50°F (T1) compared to average of first 6 minutes of freeze cycle (T2), is less than 1.05°F
		Average compressor discharge line temperature last 6 seconds of Prechill +50°F (T1) compared to average of first 6 minutes of freeze cycle (T2), is less than 1.05°F

Detail Event Log Service Definition

E-Log Display Text	Error Description	Definition
E11	Refrigeration System (Refrig Fault) Air & Water-cooled Only	The compressor discharge temperature did not increase by at least 10 F, and the evaporator temperature did not decrease by at least 10 F - Measured from Refrigeration Start up or Prechill until 2 minutes into the Freeze cycle. G Board Rev 4.017 - Event Log only no alert
E12	Curtain Fault	The ice machine is set to ice making and remains in bin full condition for more than 24 hours. The curtain switch is open or curtain is off. G Board Rev 4.017 = 24 hrs - E Board = 12 hrs
E13	Spare	
E14	Spare	
E15	Low Liq Temp	If the liquid line temperature drops below 60 F for any period exceeding continuous 1 minute during the freeze cycle. G Board Rev 4.017 - Event Log only no alert
E16	Rmt Cnd Fault	If the liquid line temperature drops below 40 F, or exceeds 140 F for more than 1 continuous minute during the freeze cycle. G Board Rev 4.017 - Event Log only no alert
E17	Spare	
E18	Spare	
E19	ITP Fault	The monitored Frequencies is out of the appropriate range (Probe unplugged or problem with microphone). G Board Rev 4.017 - Event Log only no alert
E20	WTR Fault	Any of the following: 1) Sensing high water probe and not low water probe = Water fault. 2) The Evaporator outlet temperature is less than -10°F 6.5 to 7.5 Minutes into freeze. 3) The Low Water probe is satisfied at the end of harvest. 4) Low or High water probe satisfied at end of freeze cycle. G Board Rev 4.017 - Event Log only no alert

Detail Event Log Service Definition

E-Log Display Text		Error Description	Definition
E21	T1 Fault	T1 Sensor	Each thermistor reading is monitored continuously using six second average values. During Pre-chill a thermistor had a six second average thermistor values fall outside of the valid temperature range.
E22	T2 Fault	T2 Sensor	
E23	T3 Fault	T3 Sensor	
E24	T4 Fault	T4 Sensor	
E25	Bin Prb Fault	Bin Low Sens	Each thermistor reading is monitored continuously using six second average values. A thermistor had a six second average value outside of the valid range for more than 10 continuous minutes
E26	Bin Prb Fault	Bin Med Sens	
E27	Bin Prb Fault	Bin Hi Sens	
E28	AUCS	AUCS (Aucs not Present) (Event Log only - No alarm)	When the AUCS clean option is selected from the menu, the control checks for the presence of the AUCS board and if the AUCS is not connected it will signal an Event "AUCS". This will be cleared as soon as the hardware is detected.
E29	USB COMM	USB Comm (Event Log only - No Alarm)	USB Communication error, no USB drive in port or defective USB drive
E30	USB DNLD	USB download error (dlnld) Event Log only - No alarm)	USB Download error related to USB drive or a defective USB drive
E31	Safe Mode	Safe Mode (Event Log only - No alarm)	Safe mode allows the ice machine to operate for a period of time in the event of a WLP or ITP sensor failure. The controller allows the machine to operate based on historical information collected and model data information stored in the controllers memory.

Detail Event Log Service Definition

E-Log Display Text		Error Description	Definition
E32	RS485 COMM	Event Log only - No Alarm	The device plugged into the RS485 port is not communicating between the control board and gateway.
E33	KEYBOARD	Event Log only - No Alarm	The Key board is not plugged into the control board or is faulty.
E34	DISPLAY	Event Log only - No Alarm	The Key board is not plugged into the control board or is faulty.
E36	CHECK SUM ERROR	Event Log only - No Alarm	Displays after a power loss.
E37	WATCH DOG	Event Log only - No Alarm	Process timeout, possible electrical noise.
E38	UI COMM	Event Log only - No Alarm	User interface communication error - Loose communication cable or power interruption.

USB FLASH DRIVE SPECIFICATIONS AND FORMATTING

Updating firmware on Indigo™ model ice machines requires a properly formatted 2 GB or smaller USB flash drive. All USB flash drives must be formatted before use to remove any software programs or files currently on the flash drive.

USB Flash Drive Specifications:

- USB 2 Version
- 2 GB or less capacity
- Fat32 File System
- 512 MB File Allocation Unit

USB Flash Drive Formatting:

Procedure to format a USB flash drive varies with operating system software.

Windows - Version 10 to Vista Computers:

1. Insert USB flash drive; your computer may indicate:
 - “Found New Hardware” follow the prompts to install the USB flash drive
 - USB flash drive may auto play - Close auto play window
2. Press Windows Key and E key simultaneously to access windows explorer.
3. Right click on your USB Flash Drive.
4. Left click on “Format”.
5. Verify or select the settings below:
 - USB flash drive capacity - 2 GB or less
 - File System - Fat32
 - Allocation Unit Size - Must be 512 MB
 - Volume Label is Optional - Rename if desired
 - Deselect “Perform A Quick Format” (no checkmark)
6. Left click on “Start” - You will receive a warning - “Formatting will remove all data” left click “OK”. A “Format Complete” box will display when formatting is finished. Close the pop up and windows explorer.

Windows XP Computers:

1. Insert USB flash drive; your computer may indicate:
 - “Found New Hardware” follow the prompts to install the USB flash drive
 - USB flash drive may auto launch - Close auto launch window.
2. To access Disk Management:
 - Left click on the Windows Start Button
 - Left click on “Run”
 - Type compmgmt.msc and left click on “OK”
 - Left click on “Disk Management”.
3. Verify USB flash drive capacity is 2 GB or less
4. Right click on the USB flash drive, then left click on “Format” from the drop down list.
5. Verify or select the settings below:
 - Volume Label is Optional - Rename if desired
 - File System - Fat32
 - Allocation Unit Size must be 512 MB
 - Deselect “Perform A Quick Format” (no checkmark)
6. Left click on “OK” you will receive a warning - “Formatting will remove all data” left click on “OK”, wait until formatting is complete and “status” indicates “Healthy”, then close the disk management window.

UPGRADING FIRMWARE WITH A FLASH DRIVE

Important

The flash drive must be formatted before using, All files and software on the flash drive are removed during the formatting process. Refer to page 95 USB Flash Drive Specifications and Formatting.

1. Drag and drop the files from website or email onto a flash drive. Ensure that the files are not located in a folder on the flash drive.
2. Ensure that the ice machine's power is on.
3. Press the Menu button.
4. Press the Down arrow until Service is highlighted.
5. Press the Checkmark. The Service menu will be displayed.

USB Setup



USB Stick



Download Frm



6. Press the Down arrow until USB Setup is highlighted.
7. Press the Checkmark. USB Stick will appear highlighted.
8. Press the Checkmark again. A submenu with Download Frm (Download Firmware) appears.
9. Ensure that Download Frm is highlighted and press the Checkmark. A display of instructions will appear.

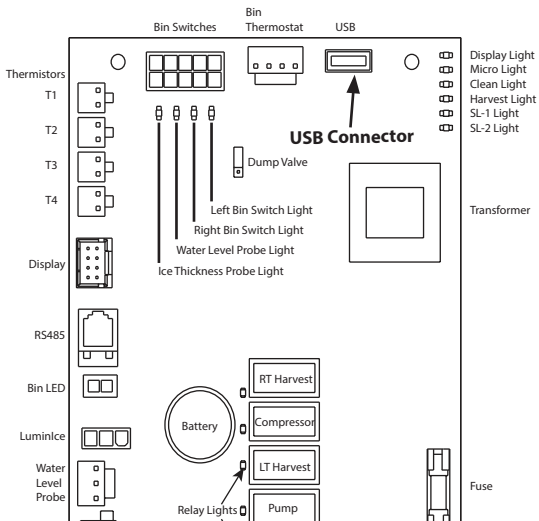

Control Board

10. Follow the on-screen instructions:

- A. Insert Drive (Insert the flash drive into the USB port on the ice machine's control board.)
- B. Press Check (Press the Checkmark.) Do not remove flash drive, touch display buttons or remove power while firmware is updating.
- C. The display will return to the home screen in the off mode.

11. Reboot control board by removing power for 15 seconds and reapplying power.

12. Verify the new firmware version loaded by navigating to Menu/Machine information/Main Software Version and verify the firmware version number.

EXPORTING DATA TO A FLASH DRIVE

Data can be copied from the control board memory to a flash drive and used to transfer setup and/or cycle data to a replacement control board or to transfer setup information to multiple ice machines. Data may also be requested by service department personnel for analysis or as an aid to troubleshooting. The data files are small and can be attached to an email.

Important

The flash drive must be formatted before using, Refer to page 95 USB Flash Drive Specifications and Formatting. All files and data are deleted during the formatting process.

1. Ensure that the ice machine's power is on.
2. Press the Menu button.
3. Press the Down arrow until Service is highlighted.
4. Press the Checkmark. The Service menu will be displayed.



5. Press the Down arrow until USB Setup is highlighted.

6. Press the Checkmark. USB Stick will appear highlighted. Press the Checkmark again. A submenu with Export ALL and Export Setup appears.

NOTE:

If these files are already on your flash drive, the control board will save the next export as:

- Asset Data - ASDATA01.CSV
- Operating Data - OPDATA01.CSV
- Real Time Data - RTDATA01.CSV
- Ice Machine Settings - SETTIN01.CSV

Select only "Ice Machine Settings" file when multiple machines will be programmed with the same user specified settings. Select "Export All" if you are installing a replacement board.

7. Highlight Export ALL or Export Setup, depending on your requirements, and press the Checkmark. A display of instructions will appear.
8. Follow these on-screen instructions to:
 - A. Insert Drive (Insert the flash drive into the USB port on the ice machine's control board.)
 - B. Press Check (Press the Checkmark.)
 - C. Wait For Comp (Wait approximately 5 to 10 minutes for the download to complete.)
 - D. Depending on software version either Export Complete, Success or the Home screen will appear.

Operational Checks

GENERAL

Manitowoc ice machines are factory-operated and adjusted before shipment. Normally, new installations do not require any adjustment.

To ensure proper operation, always follow the Operational Checks:

- when starting the ice machine for the first time
- after a prolonged out of service period
- after cleaning and sanitizing

NOTE: Routine adjustments and maintenance procedures are not covered by the warranty.

Important

Refrigeration compressors must be operated for a minimum break in period of 24 hours before full ice production will be reached.

ICE THICKNESS CHECK

After a harvest cycle, inspect the ice cubes in the ice storage bin. The ice thickness probe is factory-set to maintain the ice bridge thickness at 1/8" (3 mm).

NOTE: Make sure the water curtain or splash shield is in place when performing this check. It prevents water from splashing out of the water trough.

1. Inspect the bridge connecting the cubes. It should be about 1/8" (3 mm) thick.
2. If adjustment is necessary, turn the ice thickness probe adjustment screw clockwise to increase bridge thickness, counterclockwise to decrease bridge thickness. As a starting point place a 9/32" (7 mm) drill bit between the ice thickness probe and the evaporator. Make final adjustments to achieve a 1/8" (3 mm) thick bridge.

NOTE: Turning the adjustment 1/3 of a turn will change the ice thickness about 1/16" (1.5 mm).

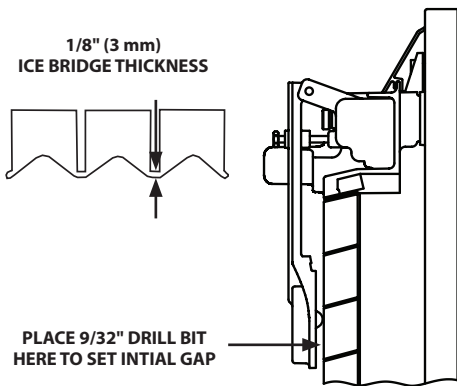

Ice Thickness Check

3. Make sure the ice thickness probe wire doesn't restrict movement of the probe.

Sequence of Operation

QUIETQUBE® MODELS

NOTE: The power button must be depressed and the water curtain/ice dampers must be in place on the evaporator before the ice machine will start.

INITIAL START-UP OR START-UP AFTER AUTOMATIC SHUT-OFF

1. Water Purge

Before the compressor starts, the water pump and water dump solenoid are energized to purge the ice machine of old water. This feature ensures that the ice making cycle starts with fresh water.

2. Refrigeration System Start-Up

Ice Machine Head Section:

The harvest valve(s), air pump(s), liquid line solenoid valve and CVD relay energize to equalize high and low side refrigeration pressure.

After 10 seconds the harvest valve(s) and air pump(s) de-energize.

ICVD Condensing Unit:

The low pressure switch closes and sends 24 volts to the control board. The control board completes the circuit through the CVD relay and sends 24 volts to the contactor coil and energizes the compressor.

FREEZE SEQUENCE

3. Prechill

The compressor lowers the temperature of the evaporator(s) before the water pump is energized. The water fill valve will energize and remain on until water completes the water level probe circuit.

4. Freeze

The water pump energizes and water flows over the evaporator. After water contacts the water level probe the water fill valve de-energizes. The control board will automatically cycle the water fill valve. The valve energizes once in the pre-chill and up to twice in the freeze cycle.

The freeze cycle continues until the six minute freeze lock expires and enough ice has formed to send a signal from the ice thickness probe to the control board.

HARVEST SEQUENCE

5. Water Purge

The air pump(s) and the harvest valve(s) open at the beginning of the water purge to divert refrigerant gas into the evaporator.

The water pump continues to run, and the water dump valve energizes to purge the water in the water trough.

ICVD Condensing Unit:

When the refrigerant pressure is low enough to open the fan cycling pressure control the condenser fan motor stops.

6. Harvest

The air pump(s) remain energized and the harvest valve(s) remains open. The refrigerant gas warms the evaporator causing the cubes to begin melting and slide, as a sheet, off the evaporator and into the storage bin.

Single evaporator models - The sliding sheet of cubes opens the water curtain/ice damper and bin switch.

The momentary opening and re-closing of the bin switch will terminate the harvest sequence and return to the freeze sequence (Step 3 - 4.)

Twin evaporator models - The sliding sheet of cubes opens the ice damper and bin switch. The momentary opening and re-closing of the bin switch de-energizes the harvest valve for that evaporator. When the bin switch has opened and closed the ice machine will terminate the harvest sequence and return to the freeze sequence (Step 3 - 4.)

AUTOMATIC SHUT-OFF

7. Automatic Shut-Off

Ice Machine Section: Shuts off when:

- The storage bin is full at the end of a harvest sequence.
- The sheet of cubes fails to clear the water curtain and holds it open.
- Ice damper is held down.
- Bin level probe thermistor senses setpoint (when used).

After the water curtain or ice damper are held open for 30 seconds, the ice machine shuts off. The ice machine remains off for 10 minutes before it can automatically restart.

ICVD Condensing Unit: The liquid line solenoid valve closes and the condensing unit pumps down. The LPCO opens and signals the control board. The control board starts a ten minute delay period and opens the 24 VAC circuit to the contactor coil, stopping the compressor and condenser fan motor.

RESTART AFTER AUTOMATIC SHUT-OFF

The ice machine remains off until enough ice has been removed to allow the ice to fall clear of the water curtain or ice damper. As the water curtain or ice damper swings back to the operating position, the bin switch re-closes and the ice machine restarts (steps 1 - 2), provided the 10 minute delay period is complete.

Single & Twin Evaporator QuietQube® Models Energized Parts Chart

Ice Making Sequence of Operation	Water Pump	Harvest Valve(s)	Air Pumps	Water Inlet Valve	Water Dump Valve	Liquid Line Solenoid Valve	Contactors Refrigeration Compressor & Condenser Fan Motor*	Length of Time
Start-Up - Initial or After Auto Shut Off	On	Off	Off	Off	On	Off	Off	45 Seconds
1. Water Purge								
2. Refrigeration System Start-up								
Pressure Equalization	Off	On	On	Off	Off	Off	Off	5 Seconds
Compressor Start	Off	On	On	Off	Off	On	On	5 Seconds
Freeze Sequence								
3. Pre chill	Off	Off	Off	May cycle On/Off	Off	On	On	Initial Start-Up is 120 Seconds 30 Seconds thereafter
4. Freeze	On	Off	Off	Cycles Off then On/Off, two more times	Off	On	On	Until Ice contact with ice thickness probe

Single & Twin Evaporator QuietQube® Models Energized Parts Chart (continued)

Ice Making Sequence of Operation	Water Pump	Harvest Valve(s)	Air Pumps	Water Inlet Valve	Water Dump Valve	Liquid Line Solenoid Valve	Contactors Refrigeration Compressor & Condenser Fan Motor*	Length of Time
Harvest Sequence	On	On	On	Off	On	On	On	Factory-set at 45 Seconds
5. Water Purge								
6. Harvest	Off	On	On	Off	Off	On	On	Bin switch activation
7. Automatic Shut-Off	Off	Off	Off	Off	Off	Off	Off	Until 3 min. delay expires & all bin switches re-close

* The condenser fan motor is controlled by a fan cycle control, therefore it may cycle on/off.

SAFETY TIMERS

The control board has the following non-adjustable safety timers:

- The ice machine is locked into the freeze cycle for 6 minutes before a harvest cycle can be initiated. This can be overridden by initiating a manual harvest. Refer to “Manual Harvest” on page 86.
- The maximum freeze time is 35 minutes at which time the control board automatically initiates a harvest sequence.
Firmware 5.009 or earlier - Maximum freeze time is 60 minutes at which time the control board automatically initiates a harvest sequence.
- The maximum harvest time is 7 minutes. The control board will perform a water thaw cycle and then return the ice machine to the freeze cycle.
Firmware 5.009 or earlier - The maximum harvest time is 3.5 minutes. The control board automatically initiates a freeze sequence when this time is exceeded.
- The maximum water fill is 12 minutes (16 minutes for dual evaporator models).

WATER ASSIST HARVEST FEATURE

Firmware version 5.010 and higher

When the damper/curtain does not open within 3.5 minutes in the harvest cycle the following occurs:

- 3.5 minutes - The water inlet valve energizes until water touches the high water level probe.
- 4 minutes - The water pump energizes.
- 6.5 to 7 minutes - The water dump valve energizes.

Twin Evaporators firmware version 5.009 and lower

- 4 minutes into a Harvest sequence: The water fill valve will energize to fill the trough with water.
- 5 minutes into a Harvest sequence: The water pump will energize and flow water over the evaporators.

The water assist harvest continues until all bin switches have been activated, or until the 7-minute Harvest time limit is reached.

Troubleshooting

Safety Limits

In addition to standard safety controls, the control board has built in safety limit controls which protect the ice machine from major component failures.

Safety limits are stored and indicated by the control board after three cycles. The number of cycles required to stop the ice machine varies for each safety limit.

- **Safety Limit 1** - If the freeze time reaches 35 minutes, the control board automatically initiates a harvest cycle. If 6 consecutive 35-minute freeze cycles occur, the ice machine stops
Firmware 5.009 or lower - If the freeze time reaches 60 minutes, the control board automatically initiates a harvest cycle. If 6 consecutive 60 minute freeze cycles occur, the ice machine stops
- **Safety Limit 2** - If the harvest time reaches 7 minutes, the control board will start a water thaw cycle and automatically return the ice machine to the freeze cycle. After 3 consecutive long harvest cycles the ice machine stops.
Firmware 5.009 or lower - If the harvest time reaches 3.5 minutes the control board will automatically start a freeze cycle. If 500 consecutive 3.5 minutes harvest cycles occur, the ice machine stops.
- **Safety Limit 2 Dual evaporator models** - Firmware 5.009 or lower - If the harvest time reaches 7 minutes, the control board automatically returns the ice machine to the freeze cycle. If 500 consecutive 7 minute harvest cycles occur, the ice machine stops.

SAFE OPERATION MODE

Allows the ice machine to operate up to 72 hours if the ice thickness probe (E19 fault) and/or water level probe sensors fail (E20 fault).

- When the control board starts the safe mode an alert is flashed on the LCD display to notify the end-user they have a production problem.
- The control board automatically initiates and monitors the safe mode. The control will automatically exit the safe mode if a normal signal is received from the input.
- After 72 hours the control board will enter a standby mode and turn off

NOTE: The control board needs a five cycle history to operate safe mode. If five cycles have never been successfully completed the ice machine will shut-off.

- Example - The ice machine is a new installation and the water has not been turned on. The ice machine will stop after five cycles with five long freeze cycles and five water system faults in the event log.

ICE THAW CYCLE

FIRMWARE VERSION 5.010 AND HIGHER

When the damper/curtain does not open during the 7 minute harvest cycle the following ice thaw cycle occurs:

- 7 minutes - The compressor, harvest solenoid valve and dump valve de-energize.
The water pump remains energized and the water inlet valve energizes until water touches the high water level probe.
- Water is circulated, dumped and refilled to the high water level probe 18 times (approximately 1 hour).
Model 1200 or smaller:
Circulate 165 seconds, dump 45 seconds
Model 1400 and larger
Circulate 240 seconds, dump 120 seconds
- At the end of the thaw cycle the ice machine will start another freeze cycle (approximately 1 - 1.75 hour).

Curtain Operation In Water Assist Harvest

- Open & close damper = Continue Thaw Cycle
- Open damper 30 seconds = Full Bin Shutoff

NOTE: Use the keypad and turn the ice machine off and then on to terminate the cycle. Disconnecting and reconnecting power to end the cycle will result in the ice machine restarting in a harvest cycle.

ANALYZING WHY A SAFETY LIMIT STOPPED THE ICE MACHINE

Safety limits are designed to stop the ice machine prior to major component failures, most often a minor problem or something external to the ice machine. This may be difficult to diagnose, as many external problems occur intermittently.

Example: An ice machine stops intermittently on safety limit #1 (long freeze times). The problem could be a low ambient temperature at night, a water pressure drop, the water is turned off one night a week, etc.

Refrigeration and electrical component failures will cause a safety limit trip. Eliminate all electrical components and external causes first. If it appears that the refrigeration system is causing the problem, use Manitowoc's Freeze Cycle Refrigeration System Operational Analysis Table, along with detailed charts, checklists, and other references to determine the cause.

The following checklists are designed to assist the service technician in analysis. However, because there are many possible external problems, do not limit your diagnosis to only the items listed.

SAFETY LIMIT #1

Firmware version 5.010 and higher

Freeze time exceeds 35 minutes for 6 consecutive freeze cycles.

Firmware version 5.009 and lower

Freeze time exceeds 60 minutes for 6 consecutive freeze cycles.

Possible cause list

Improper Installation

- Refer to "Installation/Visual Inspection Checklist" on page 134

Water System

- Defective water level probe
- Low water pressure (20 psig min.)
- High water pressure (80 psig max.)
- High water temperature (90°F/32.2°C max.)
- Clogged water distribution tube
- Dirty/defective water fill valve
- Dirty/defective water dump valve
- Defective water pump
- Loss of water from sump area

Electrical System

- Low incoming voltage
- Ice thickness probe out of adjustment
- Harvest cycle not initiated electrically
- Contactor not energizing
- Compressor electrically non-operational
- Defective fan cycling control
- Defective fan motor

Miscellaneous

- Non-Manitowoc components
- Improper refrigerant charge
- Defective head pressure control
- Defective harvest valve
- Defective compressor
- TXV starving or flooding (check bulb mounting)
- Non-condensable in refrigeration system
- Plugged or restricted high side refrigerant lines or component
- Restricted air flow/dirty condenser fins
- High inlet air temperature
- Condenser discharge air recirculation

SAFETY LIMIT #2

Firmware version 5.010 and higher

Harvest time exceeds 7 minutes for 3 consecutive harvest cycles.

Firmware version 5.009 and lower

Harvest time exceeds 3.5 minutes for 500 consecutive harvest cycles

Dual Evaporator Models - Harvest time exceeds 7 minutes for 500 consecutive harvest cycles

Possible Cause Checklist

Improper Installation

- “Installation/Visual Inspection Checklist” on page 134

Water System

- Water area (evaporator) dirty
- Dirty/defective water dump valve
- Vent tube not installed on water outlet drain
- Water freezing behind evaporator
- Plastic extrusions and gaskets not securely mounted to the evaporator
- Clogged water distribution tube

Electrical System

- Ice thickness probe out of adjustment
- Bin switch closed/defective
- Premature harvest

Refrigeration System

- Non-Manitowoc components
- Improper refrigerant charge
- Defective head pressure control valve
- Defective harvest valve
- TXV flooding (check bulb mounting)
- Defective fan cycling control

Troubleshooting By Symptom

The troubleshooting procedures follow flow charts. There are four symptoms, the symptom that you are experiencing will determine which flow chart to use. The flow chart asks yes and no questions to determine the problem. The flow chart will direct you to a procedure to correct the problem. QuietQube® remote condensing units use separate charts.

SYMPTOM #1

Ice Machine Stops Running

Ice machine is in Ice Making cycle

or

Has a History of Shutting Down

- Refer to Ice Machine Stops Running Flow Chart

SYMPTOM #2

Ice Machine has a Long Freeze Cycle.

Ice Formation is Thick

or

Thin Ice Fill on inlet or outlet of Evaporator

or

Low Production

Safety Limit #1 (possible)

- Refer to Freeze Cycle Refrigeration System Operational Analysis Table

SYMPTOM #3

Ice Machine Will Not Harvest - Freeze Cycle is Normal and Ice Cubes are Not Melted After Harvest

Safety Limit #2 (possible)

Refer to Refrigeration Harvest Flow Chart

SYMPTOM #4

Ice Machine Will Not Harvest - Freeze Cycle is Normal and Ice Cubes are Melted After Harvest

- Refer to Ice Meltout Flow Chart

RESET TO FACTORY DEFAULTS

Before starting troubleshooting procedures, reset the control board to factory defaults to prevent misdiagnosis. Before resetting to factory defaults do one of the following:

- A. Copy settings to a usb device and flash settings into the control board when diagnostics are complete.
- B. Write down any customer settings so they can be re-entered when diagnostics are complete.

This procedure also resets the password to the factory default. The default factory password is 1234. To reset the ice machine to factory defaults See "Reset Password To Factory Defaults" on "Reset Password To Factory Defaults" on page 65.

SYMPTOM #1 ICE MACHINE WILL NOT RUN

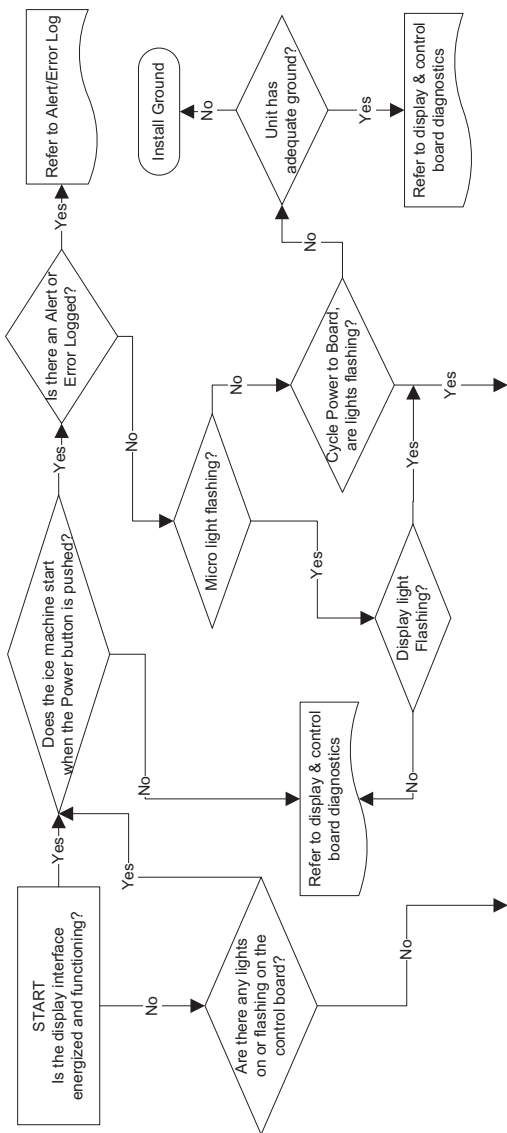

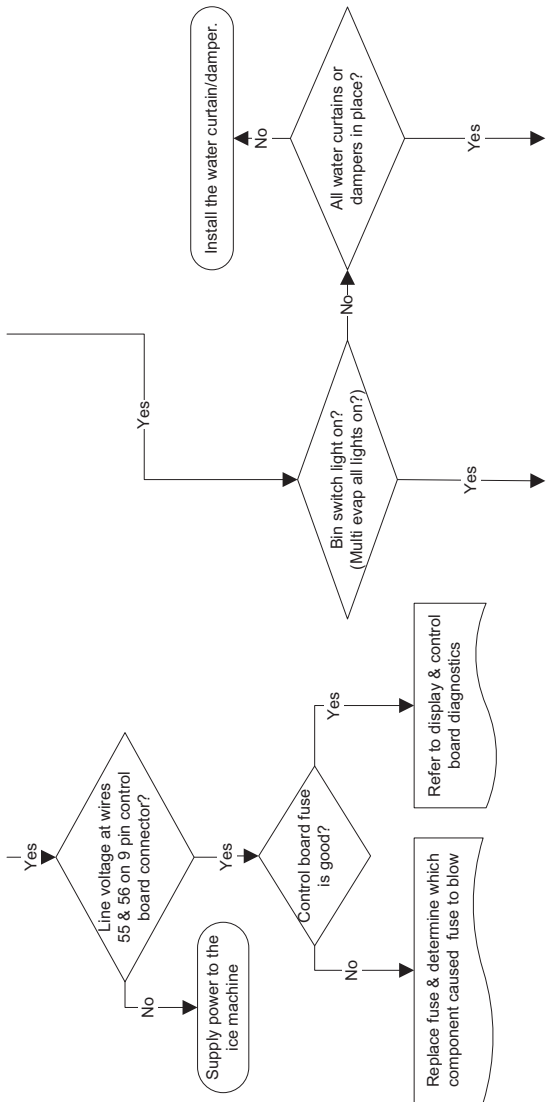

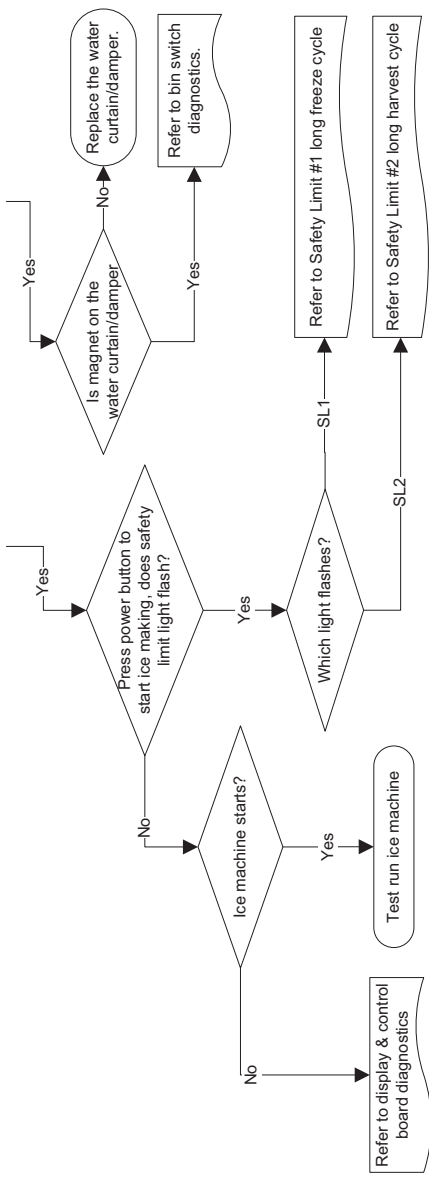

DIAGNOSING A CONDENSING UNIT THAT WILL NOT RUN

If the ice machine water pump is not energized, refer to “Diagnosing an Ice Machine that Will Not Run.

Also see “All ICVD Models Interconnecting wiring” on page 228

1. Verify primary voltage is supplied to ice machine condensing unit and the fuse/circuit breaker is closed.
2. Verify transformer is wired for the correct voltage:
 - Primary voltage measures 197v to 219v = Red & Black wires
 - Primary voltage measures 220v to 264v = Orange & Black

Important

An incorrectly wired transformer will read a secondary voltage of 24 volts, but will not carry enough power (volt amps) to properly energize components. Correctly wired transformers normally measure in the range of 27 to 28 vac. Example - 208V primary wired for 230V will measure 24 vac, but causes overheating and contactor failure.

3. Test for secondary voltage at terminals C & V - Replace transformer if not present.
4. Verify the low-pressure control is closed by testing for secondary voltage @ terminals C & LPC.
5. Verify wires are intact and ice machine is calling for cooling by testing for secondary voltage @ terminals C & HPC1.
6. Verify the high-pressure control is closed by testing for secondary voltage at the contactor coil terminals.
7. Verify the contactor contacts are closed and line voltage is present across all lines.
8. Refer to compressor diagnostics.

SYMPTOM #2 LOW PRODUCTION, LONG FREEZE CYCLE

Ice Machine has a Long Freeze Cycle.

Ice Formation is Thick

or

Thin ice fill at Inlet or Outlet of Evaporator

or

Low Production

How to Use the Freeze Cycle Refrigeration System Operational Analysis Table

GENERAL

These tables must be used with charts, checklists and other references to eliminate refrigeration components not listed on the tables and external items and problems which can cause good refrigeration components to appear defective.

The tables list five different defects that may affect the ice machine's operation.

NOTE: A low-on-charge ice machine and a starving expansion valve have very similar characteristics and are listed under the same column.

NOTE: Before starting, see "Before Beginning Service" on page 131 for a few questions to ask when talking to the ice machine owner.

PROCEDURE

Step 1 Complete the “Operation Analysis” column.

Read down the left “Operational Analysis” column. Perform all procedures and check all information listed. Each item in this column has supporting reference material to help analyze each step.

While analyzing each item separately, you may find an “external problem” causing a good refrigerant component to appear bad. Correct problems as they are found. If the operational problem is found, it is not necessary to complete the remaining procedures.

Step 2 Enter Checkmarks (√).

Each time the actual findings of an item in the “Operational Analysis” column matches the published findings on the table, enter a Checkmark.

Example: Freeze cycle suction pressure is determined to be low. Enter a Checkmark in the “low” column.

Step 3 Add the Checkmarks listed under each of the four columns. Note the column number with the highest total and proceed to “Final Analysis.”

NOTE: If two columns have matching high numbers, a procedure was not performed properly, supporting material was not analyzed correctly or the problem component is not covered by the analysis table.

FREEZE CYCLE REFRIGERATION SYSTEM OPERATIONAL ANALYSIS TABLES
I Model QuietQube® Single Expansion Valve

	1	2	3	4
Operational Analysis				
Ice Production	Published 24 hour ice production _____ Calculated (actual) ice production _____ NOTE: The ice machine is operating properly if the ice fill patterns is normal and ice production is within 10% of charted capacity.			
Installation and Water System	See "QuietQube® Models - Ice Production Check" on page 132 All installation and water related problems must be corrected before proceeding with chart. See "QuietQube® Models - Installation/Visual Inspection Checklist" on page 133			
Ice Formation Pattern See "QuietQube® Models - Ice Formation Pattern" on page 136	Ice formation is extremely thin on outlet of evaporator -or- No ice formation on the entire evaporator	Ice formation normal -or- Ice formation is extremely thin on outlet of evaporator -or- No ice formation on entire evaporator	Ice formation normal -or- Ice formation is extremely thin on inlet of evaporator -or- No ice formation on entire evaporator	Ice formation normal -or- No ice formation on entire evaporator

I Model QuietQube® Single Expansion Valve

Operational Analysis	1	2	3	4
Safety Limits Refer to "Analyzing Safety Limits" page 114 to eliminate all non-refrigeration problems.	Stops on safety limit: 1 or 2	Stops on safety limit: 1 or 2	Stops on safety limit: 1 or 2	Stops on safety limit: 1
Freeze Cycle Discharge Pressure _____ Middle _____ End 1 minute into cycle	If discharge pressure is High or Low refer to freeze cycle high or low discharge pressure problem checklist page 139 & page 140 to eliminate problems and/or components not listed on this table before proceeding.			
Freeze Cycle Suction Pressure _____ Middle _____ End 1 minute	If suction pressure is High or Low refer to freeze cycle high or low suction pressure problem checklist page 142 & page 143 to eliminate problems and/or components not listed on this table before proceeding.			
Harvest Valve	Suction pressure is High Audible refrigerant flow through harvest valve in Freeze cycle	Suction pressure is Low or Normal No audible refrigerant flow through harvest valve in Freeze cycle	Suction pressure is Normal or High No audible refrigerant flow through harvest valve in Freeze cycle	Suction pressure is High No audible refrigerant flow through harvest valve in Freeze cycle

I Model QuietQube® Single Expansion Valve

Operational Analysis	1	2	3	4
Suction Line Temperature Attach a temperature probe on the suction line with-in 6" of the shut-off valve outlet. Record the low event at the end of the freeze cycle	Suction line temp. at the suction shut-off valve is greater than 10°F (-12.2°C) at the end of the freeze cycle	Suction line temp. at the suction shut-off valve is greater than 10°F (-12.2°C) at the end of the freeze cycle	Suction line temp. at the suction shut-off valve is less than 10°F (-12.2°C) at the end of the freeze cycle	Suction line temp. at the suction shut-off valve is greater than 10°F (-12.2°C) at the end of the freeze cycle
Final Analysis Enter total number of boxes checked in each column.	Harvest Valve Leaking	Low On Charge -Or- TXV Starving	Refrigerant Overcharge -Or- TXV Flooding	Compressor

Freeze Cycle Refrigeration System Operational Analysis Tables
Twin Expansion Valve – I1470C/I1870C/I2170C Models

Operational Analysis	1	2	3	4
Ice Production	Published 24-hour ice production _____ Calculated (actual) 24-hour ice production _____			
Installation and Water System Ice Formation Pattern See "QuietCube® Models - Ice Formation Pattern" on page 136 Top Half _____ or Left _____ Bottom Half _____ or Right _____	Ice formation is extremely thin on outlet of one evaporator -or- No ice formation on top of one evaporator	Ice formation is normal -or- Ice formation is extremely thin on outlet of one or both evaporators -or- No ice formation on one or both evaporators	Ice formation is normal -or- Ice formation is extremely thin on the inlet of one evaporator -or- No ice formation on one evaporator	Ice formation is normal -or- No ice formation on both evaporators
	All installation and water-related problems must be corrected before proceeding with chart.			

Twin Expansion Valve – I1470C/I1870C/I2170C Models

Operational Analysis	1	2	3	4
Safety Limits Refer to "Analyzing Safety Limits" page 114 to eliminate all non-refrigeration problems.	Stops on safety limit: 1 or 2	Stops on safety limit: 1 or 2	Stops on safety limit: 1 or 2	Stops on safety limit: 1
Freeze Cycle Discharge Pressure _____ Middle _____ End 1 minute	If discharge pressure is High or Low, refer to Freeze cycle high or low discharge pressure problem checklist page 142 & page 143 to eliminate problems and/or components not listed on this table before proceeding.			
Freeze Cycle Suction Pressure _____ Middle _____ End 1 minute	If suction pressure is High or Low, refer to Freeze cycle high or low suction pressure problem checklist page 142 & page 143 to eliminate problems and/or components not listed on this table before proceeding.			
	Suction pressure is High	Suction pressure is Low or Normal	Suction pressure is High or Normal	Suction pressure is High

Twin Expansion Valve – I1470C/I1870C/I2170C Models

	1	2	3	4
Operational Analysis Harvest Valve	Audible refrigerant flow through left or right valve in Freeze cycle	No audible refrigerant flow through left or right valve in Freeze cycle	No audible refrigerant flow through left or right valve in Freeze cycle	No audible refrigerant flow through left or right valve in Freeze cycle
Suction Line Temperature Attach a temperature probe on the suction line within 6 in. of the shut-off valve outlet. Record the low event at the end of the Freeze cycle.	Suction line temperature at the suction shut-off valve is greater than 10°F (-12.2°C) at the end of the Freeze cycle	Suction line temperature at the suction shut-off valve is greater than 10°F (-12.2°C) at the end of the Freeze cycle	Suction line temperature at the suction shut-off valve is less than 10°F (-12.2°C) at the end of the Freeze cycle	Suction line temperature at the suction shut-off valve is greater than 10°F (-12.2°C) at the end of the Freeze cycle
Final Analysis Enter total number of boxes checked in each column.	Harvest Valve Leaking	Low on charge -or- TXV starving	Refrigerant Overcharge -or- TXV flooding	Compressor

FREEZE CYCLE REFRIGERATION SYSTEM OPERATIONAL ANALYSIS TABLE PROCEDURES - QUIETQUBE® MODELS

The following is the procedures for completing each step of the Freeze Cycle Refrigeration System Operational Analysis Tables. Each procedure must be performed exactly for the table to work correctly.

Before Beginning Service

Ice machines may experience operational problems only during certain times of the day or night. A machine may function properly while it is being serviced, but malfunctions later. Information provided by the user can help the technician start in the right direction, and may be a determining factor in the final diagnosis.

Ask these questions before beginning service:

- When does the ice machine malfunction? (night, day, all the time, only during the Freeze cycle, etc.)
- When do you notice low ice production? (one day a week, every day, on weekends, etc.)
- Can you describe exactly what the ice machine seems to be doing?
- Has anyone been working on the ice machine?
- During "store shutdown," is the circuit breaker, water supply or air temperature altered?
- Is there any reason why incoming water pressure might rise or drop substantially?

Ice Production Check

The amount of ice a machine produces directly relates to the operating water and air temperatures. This means a condensing unit with a 70°F (21°C) outdoor ambient temperature and 50°F (10°C) water produces more ice than the same model condensing unit with a 90°F (32°C) outdoor ambient temperature and 70°F (21°C) water.

1. Determine the ice machine operating conditions:

Air temp entering condenser: _____°

Air temp around ice machine: _____°

Water temp entering sump trough: _____°

2. Refer to the appropriate 24-Hour Ice Production Chart (starting on page 211). Use the operating conditions determined in step 1 to find published 24-Hour Ice Production: _____

- Times are in minutes.

Example: 1 min. 15 sec. converts to 1.25 min.
(15 seconds ÷ 60 seconds = .25 minutes)

- Weights are in pounds.

Example: 2 lb. 6 oz. converts to 2.375 lb.
(6 oz. ÷ 16 oz. = .375 lb.)

3. Perform an ice production check using the formula below.

1.	_____	+	_____	=	_____
	Freeze Time		Harvest Time		Total Cycle Time
2.	$\frac{1440}{\text{Minutes in 24 Hrs.}}$	÷	_____	=	_____
			Total Cycle Time		Cycles per Day
3.	_____	×	_____	=	_____
	Weight of One Harvest		Cycles per Day		Actual 24-Hour Production

Weighing the ice is the only 100% accurate check. However, if the ice pattern is normal and the 1/8 in. thickness is maintained, the ice slab weights listed with the 24-Hour Ice Production Charts may be used.

4. Compare the results of step 3 with step 2. Ice production checks that are within 10% of the chart are considered normal. If they match closely, determine if:
 - Another ice machine is required.
 - More storage capacity is required.
 - Relocating the existing equipment to lower the load conditions is required.

Contact the local Manitowoc Distributor for information on available options and accessories.

Installation/Visual Inspection Checklist

Inadequate Clearances

- Check all clearances on sides, back and top.
See "Clearance Requirements" on page 25

Ice machine is not level

- Level the ice machine

Condenser is dirty

- Clean the condenser

Water filtration is plugged (if used)

- Install a new water filter

Water drains are not run separately and/or are not vented

- Run and vent drains according to the Installation Manual

Line set is improperly installed

- Reinstall according to the Installation, Operation and Maintenance Manual

Lineset is the incorrect size

- Refer to Installation, Operation and Maintenance Manual
See "Lineset Applications" on page 29

Water System Checklist

A water-related problem often causes the same symptoms as a refrigeration system component malfunction.

Water system problems must be identified and eliminated prior to replacing refrigeration components.

Water area (evaporator) is dirty

- Clean as needed

Water inlet pressure not between 20 and 80 psig (1-5 Bar, 138-552 kPa).

- Install water regulator or increase water pressure

Incoming water temperature is not between 35°F (2°C) and 90°F (32°C)

- If too hot, check the hot water line check valves in other store equipment

Water filtration is plugged (if used)

- Install a new water filter

Water dump valve leaking during the Freeze cycle

- Clean or replace dump valve as needed

Vent tube is not installed on water outlet drain

- See Installation Instructions

Hoses, fittings, etc., are leaking water

- Repair or replace as needed

Water fill valve is stuck open or closed

- Clean or replace as needed

Water is leaking out of the sump trough area

- Stop the water loss

Uneven water flow across the evaporator

- Clean the ice machine

Plastic extrusions and gaskets are not secured to the evaporator

- Remount/replace as needed

Ice Formation Pattern

Evaporator ice formation pattern analysis is helpful in ice machine diagnostics.

Analyzing the ice formation pattern alone cannot diagnose an ice machine malfunction. However, when this analysis is used along with Manitowoc's Freeze Cycle Refrigeration System Operational Analysis Tables, it can help diagnose an ice machine malfunction.

Any number of problems can cause improper ice formation.

Important

Keep the water curtain, splash shields and ice dampers in place while checking the ice formation pattern to ensure no water is lost.

1. Normal Ice Formation

Ice forms across the entire evaporator surface.

At the beginning of the Freeze cycle, it may appear that more ice is forming on the inlet of the evaporator than on the outlet. At the end of the Freeze cycle, ice formation at the outlet will be close to, or just a bit thinner than, ice formation at the inlet. The dimples in the cubes at the outlet of the evaporator may be more pronounced than those on the inlet. This is normal.

It is normal for ice thickness to vary up to 1/16" across the surface of the evaporator. The ice bridge thickness at the ice thickness control probe should be at least 1/8".

The ice thickness probe must be set to maintain the ice bridge thickness at approximately 1/8 in. If ice forms uniformly across the evaporator surface, but does not reach 1/8 in. in the proper amount of time, this is still considered a normal ice fill pattern.

2. Extremely Thin at Evaporator Outlet

There is no ice, or a considerable lack of ice formation, at the outlet of the evaporator.

Examples: No ice at all on the outlet half of the evaporator, but ice forms on the inlet half of the evaporator. Or, the ice at the outlet of the evaporator reaches 1/8 in. to initiate a harvest, but the inlet of the evaporator already has 1/2 in. to 1 in. of ice formation.

3. Extremely Thin at Evaporator Inlet

There is no ice, or a considerable lack of ice formation at the inlet of the evaporator. Examples: The ice at the outlet of the evaporator reaches 1/8 in. to initiate a harvest, but there is no ice formation at all on the inlet of the evaporator.

4. No Ice Formation

The ice machine operates for an extended period, but there is no ice formation at all on the evaporator.

Evaporator Tubing Routing

Routing of the tubing on the back of the evaporator determines the ice fill pattern failure mode. The evaporator outlet tubing does not exit directly at the top of the evaporator, but exits several inches below the top of the evaporator. Extremely Thin at the Evaporator Outlet will first be visible several inches below the top of the evaporator. Extremely Thin at Evaporator Inlet will first be visible at the bottom of the evaporator.

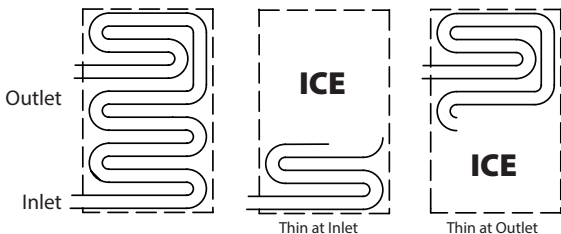

One Evaporator, Two TXV Models

Tubing routing for one evaporator with two TXV's is different. The evaporator has two inlets and outlets. Fill pattern varies depending on which circuit is affected.

Extremely Thin at the Evaporator Outlet will first be visible either 1/4 or 3/4 of the way down the evaporator.

Extremely Thin at the Evaporator Inlet will show at the bottom of the evaporator or 1/2 of the way down depending on the circuit affected.

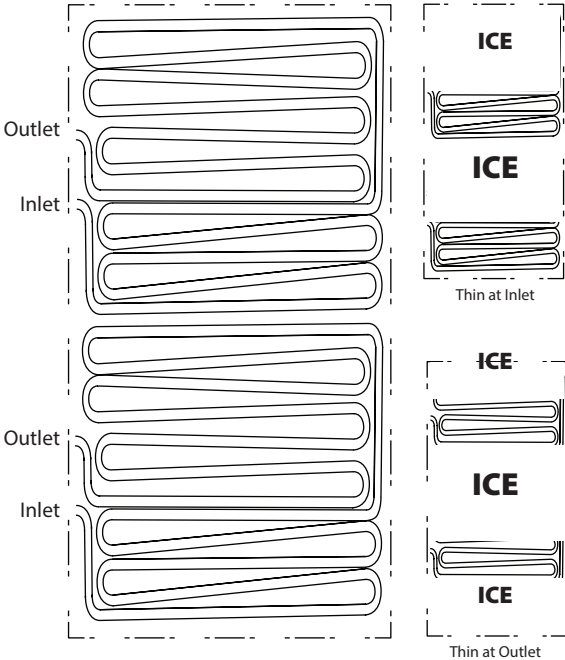

Analyzing Discharge Pressure in the Freeze Cycle

1. Determine the ice machine operating conditions:

Air temp. entering condenser _____

Air temp. around ice machine _____

Water temp. entering sump trough _____

2. Refer to "Cycle Times/24-Hour Ice Production/Refrigerant Pressure Charts" on page 213 for ice machine being checked.

Use the operating conditions determined in step 1 to find the published normal discharge pressures.

Freeze Cycle _____

Harvest Cycle _____

3. Perform an actual discharge pressure check.

**Freeze Cycle
psig (kPa)**

1 Minute into

the Freeze Cycle

Middle of Freeze Cycle

End of Freeze Cycle

4. Compare the actual discharge pressure (step 3) with the published discharge pressure (step 2).

The discharge pressure is normal when the actual pressure falls within the published pressure range for the ice machine's operating conditions. It is normal for the discharge pressure to be higher at the beginning of the Freeze cycle (when load is greatest), then drop throughout the Freeze cycle.

FREEZE CYCLE DISCHARGE PRESSURE HIGH CHECKLIST

Improper Installation

- Refer to "Installation/Visual Inspection Checklist" on page 134

Air Condenser

- Dirty condenser filter
- Dirty condenser fins
- High inlet air temperature
- Condenser discharge air recirculation
- Defective "Fan Cycle Control" on page 182)
- Defective fan motor
- Defective head pressure control valve {Remote}

Other

- Overcharged
- Non-condensable (air) in system
- Wrong type of refrigerant
- Non-Manitowoc components in system
- High side refrigerant lines/component restricted

FREEZE CYCLE DISCHARGE PRESSURE LOW CHECKLIST

Improper Installation

- Refer to “Installation/Visual Inspection Checklist” on page 134

Condenser

- Defective head pressure control valve, won't bypass page 192
- Defective fan cycle control, stuck closed (page 182)

Other

- Undercharged
- Wrong type of refrigerant
- Non-Manitowoc components in system
- Liquid line/component restricted

Analyzing Suction Pressure

The suction pressure gradually drops throughout the freeze cycle. The actual suction pressure (and drop rate) changes as the air and water temperature entering the ice machine changes. These variables also determine the freeze cycle times.

To analyze and identify the proper suction pressure drop throughout the freeze cycle, compare the published suction pressure to the published freeze cycle time.

NOTE: Analyze discharge pressure before analyzing suction pressure. High or low discharge pressure may be causing high or low suction pressure.

1. Determine the ice machine operating conditions:

Air temp. entering condenser _____

Air temp. around ice machine _____

Water temp. entering sump trough _____

2. Refer to Operating Pressure table (starting on page 211) for ice machine being checked.

Use the operating conditions determined in step 1 to find the published normal discharge pressures.

Freeze Cycle _____

Harvest Cycle _____

3. Perform an actual suction pressure check.

	Freeze Cycle psig (kPa)
1 Minute into the Freeze Cycle	_____
Middle of Freeze Cycle	_____
End of Freeze Cycle	_____

4. Compare the actual suction pressure (step 3) with the published suction pressure (step 2).

NOTE: The suction pressure is normal when the actual pressure falls within the published pressure range for the ice machine's operating conditions. It is normal for the suction pressure to be higher at the beginning of the Freeze cycle (when load is greatest), then drop throughout the Freeze cycle.

Suction Pressure High Checklist

Improper Installation

- Refer to "Installation/Visual Inspection Checklist" on page 134

Discharge Pressure

- Discharge pressure is too high and is affecting suction pressure – refer to "Analyzing Discharge Pressure in the Freeze Cycle" on page 139

Improper Refrigerant Charge

- Overcharged
- Wrong type of refrigerant
- Non condensable in system

Components

- Harvest valve leaking
- TXV flooding
- Defective compressor

Other

- Non-Manitowoc components in system

SUCTION PRESSURE LOW CHECKLIST

Improper Installation

- Refer to "Installation/Visual Inspection Checklist" on page 134

Discharge Pressure

- Discharge pressure is too low and is affecting low side – refer to "Analyzing Discharge Pressure in the Freeze Cycle" on page 139

Improper Refrigerant Charge

- Undercharged
- Wrong type of refrigerant

Other

- Non-Manitowoc components in system
- Improper water supply over evaporator – refer to "Water System Checklist" on page 135
- Restricted/plugged liquid line drier
- Restricted/plugged tubing in suction side of refrigeration system
- TXV starving
- Liquid line solenoid valve closed

Harvest Valve Analysis

Symptoms of a harvest valve remaining partially open during the freeze cycle can be similar to symptoms of either an expansion valve or compressor problem. The best way to diagnose a harvest valve is by using Manitowoc's Ice Machine Freeze Cycle Refrigeration System Operational Analysis Table.

Use the following procedures to determine if a harvest valve is remaining partially open during the freeze cycle.

QUIETQUBE® HARVEST VALVE ANALYSIS

The valve can fail in two positions:

- Valve will not open in the Harvest cycle.
- Valve remains open during the Freeze cycle.

Valve will not open in the Harvest cycle

Although the circuit board has initiated a Harvest cycle, suction and discharge pressures remain unchanged from the Freeze cycle. The ice machine will remain in the Harvest cycle for 3.5 minutes, then initiate a water thaw cycle.

Valve remains open in the Freeze cycle

Symptoms of a harvest valve remaining partially open during the Freeze cycle can be similar to symptoms of an expansion valve or compressor problem. Symptoms are dependent on the amount of leakage in the Freeze cycle.

A small amount of leakage will cause increased freeze times and an ice fill pattern that is normal.

As the amount of leakage increases, the length of the Freeze cycle increases and the amount of ice on the bottom of the evaporator decreases.

A small amount of leakage will cause an audible indication as the vapor passes through the valve. As the size of the leak increases, the audible indication becomes more apparent.

Analyzing Freeze Cycle Suction Line Temperature

Suction line temperature alone cannot diagnose an ice machine. However, comparing this temperature during the freeze cycle, along with using Manitowoc's Symptom #2 - Refrigeration System Operational Analysis Table, can help diagnose an ice machine malfunction.

The actual temperature of the suction line varies by model, and will change throughout the freeze cycle. This makes documenting the "normal" suction line temperature difficult. The key to the diagnosis is observing the compressor suction line temperature during the last three minutes of the freeze cycle.

1. Navigate to Service / Real Time Data / Time & Temp / T3 & T4 Thermistors (See page 83 Service Menu Navigation for details).
2. Monitor the suction line temperature during the last three minutes of the freeze cycle and record the low event.
3. Use this with other information gathered on the Refrigeration Component Analysis Chart to determine the ice machine malfunction.
4. Verify refrigerant amount is correct by weight when recovering refrigerant and replacing a TXV. Grossly overcharged QuietQube® ice machine in ambient temperatures below 70°F will have a suction line temperature below 10°F.

Final Analysis

The column with the highest number of Checkmarks identifies the refrigeration problem.

COLUMN 1 - HARVEST VALVE LEAKING

Replace the valve as required.

COLUMN 2 - LOW CHARGE/TXV STARVING

Normally, a starving expansion valve only affects the freeze cycle pressures, not the harvest cycle pressures. A low refrigerant charge normally affects both pressures. Verify the ice machine is not low on charge before replacing an expansion valve.

1. Do not add charge to QuietQube models. The symptoms of a QuietQube condensing unit low on charge will result in a safety limit #1 in cool ambient temperatures. Check the liquid line temperature at the ice machine. The liquid line will be hot with a normal or below normal head pressure in freeze when the ice machine is low on refrigerant.
2. Find the refrigerant leak. The ice machine must operate with the nameplate charge. If the leak cannot be found, proper refrigerant procedures must still be followed Change the liquid line drier. Then, evacuate and weigh in the proper charge.
3. Verify refrigerant charge by weight when recovering to prevent misdiagnosis of the expansion valve.

COLUMN 3 - TXV FLOODING OR REFRIGERANT OVERCHARGE

A loose or improperly mounted expansion valve bulb causes the expansion valve to flood. Check bulb mounting, insulation, etc., before changing the valve. Verify refrigerant amount is correct by weighing recovered refrigerant before replacing a TXV.

COLUMN 4 - COMPRESSOR

Replace the compressor. To receive warranty credit, the compressor ports must be properly sealed by crimping and soldering them closed.

SYMPTOM #3 HARVEST PROBLEMS

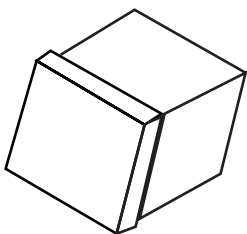

Normal Ice Cube

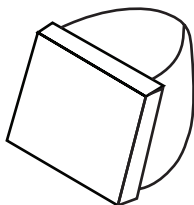

Melted Out Ice Cube

Definition of a harvest problem; At the end of a 3.5 minute harvest cycle (7 minutes dual evaporators) the slab(s) of ice is still contacting the evaporator. The slab of ice may or may not be removable by hand.

Harvest problems can be split into two categorizes.

- Melted sheet of cubes at the end of the harvest cycle. Ice can be removed rather easily by hand. The back of the cubes are misshapen and melted. This indicates something is on the evaporator preventing the ice slab from releasing. Follow the appropriate flow chart (in Troubleshooting) to determine the cause of the problem. A manual cleaning procedure must always be performed when this problem is encountered.
- Normal sheet of cubes at the end of the harvest cycle. Ice is difficult to remove from the evaporator by hand. Once removed the back of the cubes are square and show no signs of melting. This indicates a refrigeration problem. The source of the problem could be in the freeze or harvest cycle. Use the appropriate flow chart (in Troubleshooting) to determine the cause of the problem.

SYMPTOM #3 QUIETQUBE® MODELS WITH ICVD CONDENSING UNITS

ICE MACHINE WILL NOT HARVEST - FREEZE CYCLE NORMAL, CUBES ARE NOT MELTED

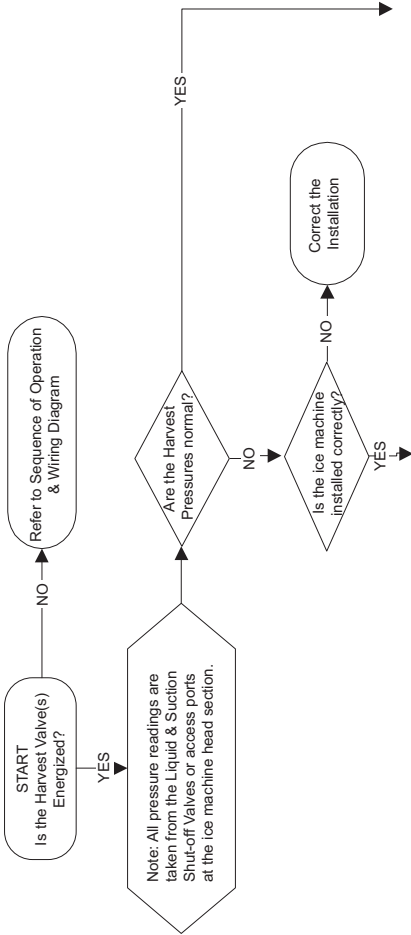

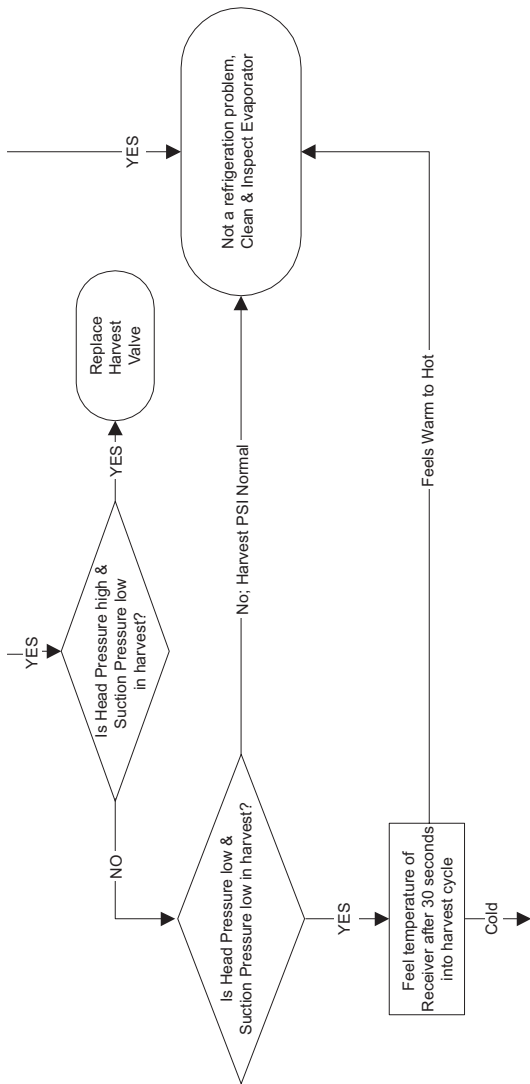

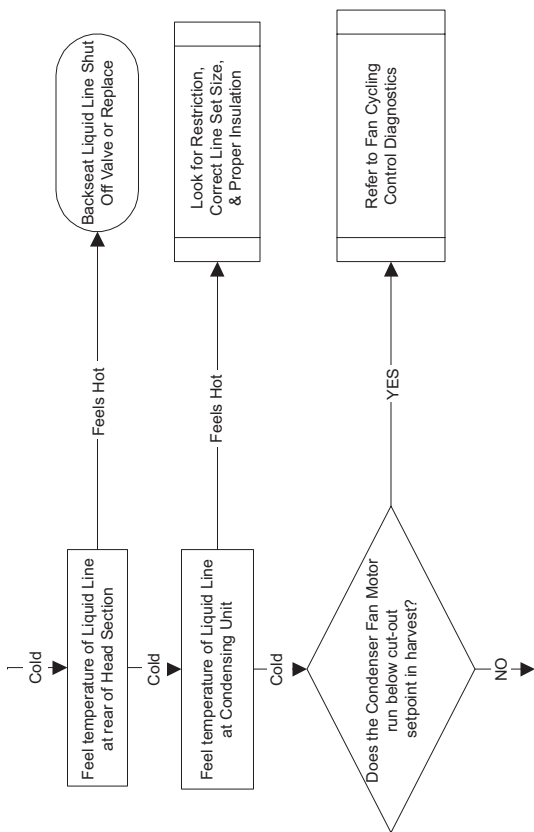

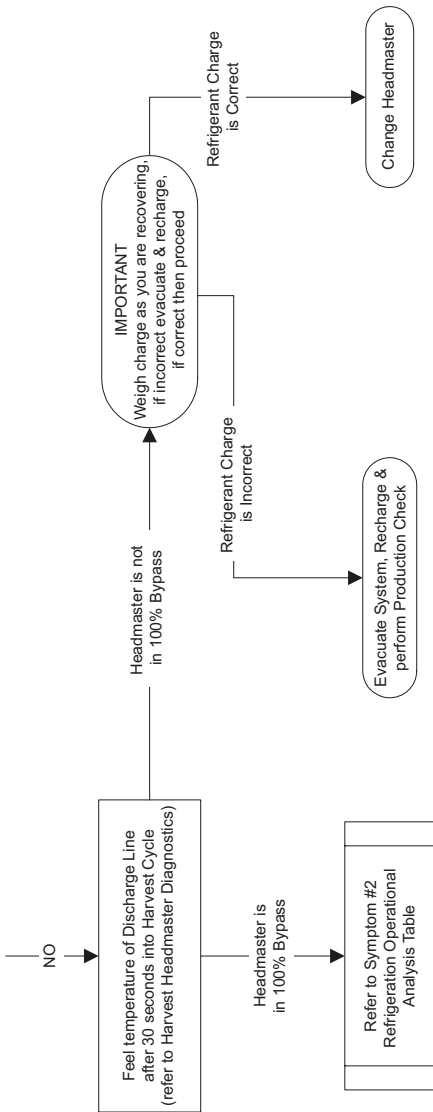

SYMPTOM #4 QUIETQUBE® MODELS WITH ICVD CONDENSING UNITS

Ice Machine Will Not Harvest - Freeze Cycle Is Normal and Ice Cubes Are Melted After Harvest

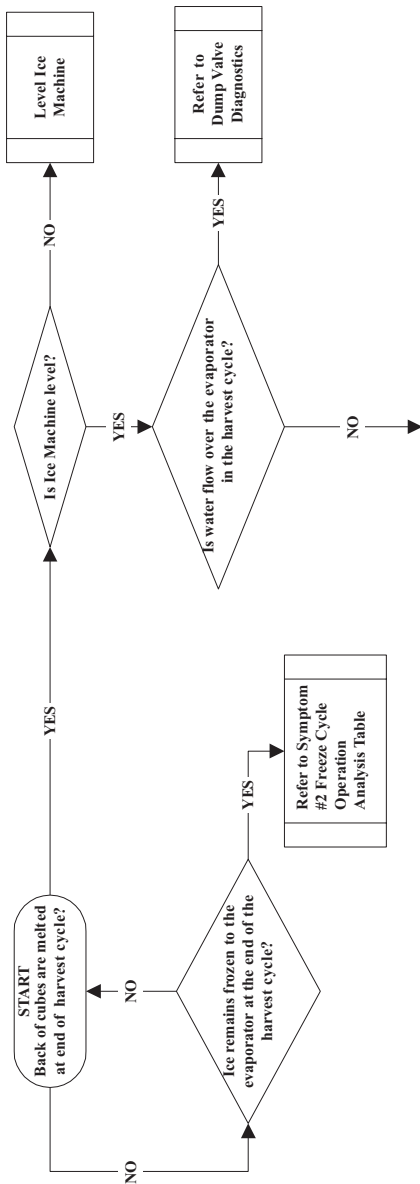

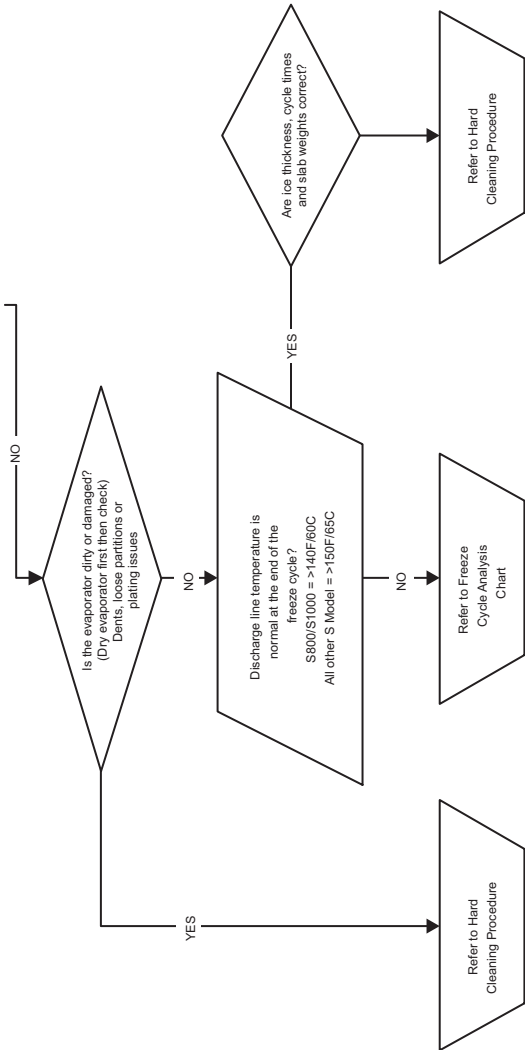

THIS PAGE INTENTIONALLY LEFT BLANK

Component Check Procedures

Electrical Components

CONTROL BOARD, DISPLAY BOARD, TOUCH PAD

FUNCTION

The control board, display board and touch pad provide user input and control the ice machine sequence of operation.

NOTE: Anytime power is supplied to wires #55 & #56 on the control board, the "Display" and "Micro" lights should flash like a heartbeat. The two green lights are located on the top right corner of the control board.

Display Diagnostics

Symptom - Micro light flashes and display light is off.

1. Disconnect both ends of the communication cable running between the control board and the back of the display module and inspect for bent or damaged pins. Reconnect after inspection.
2. Reboot ice machine by disconnecting power for a minimum of 15 seconds, reapplying power and checking micro light for normal flashing.
3. Press the power button on the display and watch the green Display light on the control board.
 - A. Display light flashes - Test run ice machine.
 - B. Display light is off - Replace communication cable first as a test, then replace display/touch pad assembly if required.

Control Board Diagnostics

1. Micro light is not flashing a heartbeat.
2. Disconnect line voltage power supply to the ice machine and wait a minimum of 15 seconds, then reapply power.
 - A. Micro light flashes - continue with step 3.
 - B. Micro light is off - Replace control board.
3. Perform the following keystrokes on the display.
 - Press Menu, scroll down to Service and press right arrow
 - Scroll down to Diagnostics and press right arrow
 - Display reads Control Board, press right arrow
 - Display reads Self Check, press right arrow to start control board test

The control board performs a self test. As the test progresses the display will show Checkmarks at the top left of the display screen. When the fifth Checkmark appears the display will show "Status Failed" or "Status Passed".

- Status passed -The control board is functioning normally, continue with touch pad diagnostics on next page.
- Status failed - Replace control board.

Touch Pad Diagnostics

Follow the control board diagnostics to "Status Passed". Perform the following keystrokes on the display.

- Display reads Status Passed, press the right arrow
 - Display reads Pass Yes, press the right arrow
 - Display reads Key Pad Test, press the right arrow
4. Test the functionality of all buttons on the touch pad.

NOTE: Pushing the power button will start and stop the ice machine. Testing it last will allow the ice machine to continue running a freeze cycle.

- As you press the buttons the first letter of the corresponding word will flash indicating the push button is operating correctly
 - Press the right arrow 5 times rapidly to exit.
5. Display reads Pass Yes and Pass No.
- Press left arrow 4 times to exit to home screen.

CONTROL BOARD RELAY TEST

The control board can be set to energize all relays for 3.5 minutes. This allows testing to verify control board relays are closed and line voltage is available for ice machine components - Water pump, dump valve, water inlet valve, harvest valve(s), air compressor(s), contactor/compressor/fan motor - The fan cycle control must close to energize the fan motor.

1. Press power button to turn off ice machine.
2. Perform the following keystrokes on the display.
 - Press Menu, scroll down to Service and press the right arrow
 - Scroll down to Diagnostics, press the right arrow and select Diagnostics
 - Display reads Control Board, press right arrow
 - Scroll down to enbl relays and press right arrow to start control board test
3. The control board will energize all relays and the red light next to the relay. The red light indicates the relay coil is energized.
4. Test for line voltage at the individual components.
 - A. Line voltage is present and the component is non functional - Replace component
 - B. Voltage is not present at the component - Proceed to step 5
5. Refer to wiring diagram and determine wire location on the 9 pin molex connector for the component you are testing.
6. Check for line voltage at the control board 9 pin molex connector.
 - A. Line voltage at 9 pin connector - Repair wiring to component
 - B. No power at 9 pin connector - Replace control board

PROGRAMMING A REPLACEMENT BOARD

Indigo™ replacement control boards require the Model number to be entered to activate the appropriate look up tables for operation and diagnostic. This can be done two different ways, USB Setup or Manual Setup.

USB Setup - Applicable when the control board is operational and has a mechanical issue such as a sticking relay. The asset data is transferred to the replacement control board from the faulty control board. Refer to page 99 “Exporting Data To A Flash Drive” before installing the replacement board.

Manual Setup - Applicable when the control board is non-operational or data from the faulty board is suspect.

Install replacement control board and reapply power.

- G series (blue) control boards will go directly to the Replacement Control Board screen and pause for input - Select either “Manual” or “USB” setup option.
- E series (beige) control boards require navigation to the Replacement Control Board (Repl Cntl Bd) screen.
 1. Press the Menu button.
 2. Press the Down arrow until Service is highlighted, then press the Checkmark.
 3. Scroll down to Replacement Control Board and press the Checkmark.
 4. Select “Manual Setup” and press the Checkmark.

Verify the date correctly auto populates.

- Yes - Go to step 5
- No - Press the right arrow to activate the cursor, then use up/down arrows to enter the correct date.

5. Scroll down until brackets are in the space below "Input Model #". Press the right arrow to activate the blinking cursor, then use the up/down arrows to select the first character in the model number. Use the right arrow to move to the next space. Add characters in this manner until the model number is complete. The model must include the dash and the last three numbers to indicate the electrical requirements (example -261, do not add any additional letters). Press the right arrow until the cursor disappears.

For example a model number listed on the data plate may show #ID1076C-161X but the display would only show #ID1076C-161.

6. Scroll down until brackets are in the space below "Input Serial#". Press the right arrow to activate the blinking cursor, then use the up/down arrows to select the first character in the serial number. Use the right arrow to move to the next space. Add characters in this manner until the serial number is complete. Press the right arrow until the cursor disappears.
7. Scroll down and select exit, then press checkmark.
8. Reboot ice machine by disconnecting power for a minimum of 15 seconds, then reapply power.

MAIN FUSE

FUNCTION

The control board fuse stops ice machine operation if electrical components fail, causing high amp draw.

SPECIFICATIONS

The main fuse is 250 Volt, 8 amp.

⚠ Warning

High (line) voltage is applied to the control board (terminals #55 and #56) at all times. Removing the control board fuse or pressing the On/Off button will not remove the power supplied to the control board.

CHECK PROCEDURE

1. If the bin switch light is on with the water curtain/ice dampers closed, the fuse is good.

⚠ Warning

Disconnect electrical power to the entire ice machine before proceeding.

2. Remove the fuse. Check for continuity across the fuse with an ohmmeter.

Reading	Result
Open (OL)	Replace fuse
Closed (O)	Fuse is good

BIN SWITCH

FUNCTION

Movement of the water curtain/ice dampers control bin switch operation. The bin switch has two main functions:

1. Terminating the Harvest cycle and returning the ice machine to the Freeze cycle. This occurs when the bin switch is opened and closed again within 30 seconds during the Harvest cycle.
2. Automatic ice machine shut-off.
If the storage bin is full at the end of a Harvest cycle, the sheet of cubes fails to clear the water curtain/ice dampers and holds it open. After the water curtain/ice dampers are held open for 30 seconds, the ice machine shuts off. The ice machine remains off until enough ice is removed from the storage bin to allow the sheet of cubes to drop clear of the water curtain/ice dampers. As the water curtain/ice dampers swing back to the operating position, the bin switch closes and the ice machine restarts, provide the 3-minute delay has expired.

Important

The water curtain/ice dampers must be ON (bin switch closed) to start ice making.

SPECIFICATIONS

The bin switch is a magnetically operated reed switch. The magnet is attached to the lower right corner of the water curtain and both ends of ice dampers.

The bin switch is connected to a varying D.C. voltage circuit. (Voltage does not remain constant.)

NOTE: Because of a wide variation in D.C. voltage, it is not recommended that a voltmeter be used to check bin switch operation.

Diagnostics

SYMPTOMS

Bin Switch Fails Open

G Model control boards or E Model control boards with firmware version Rev.2.047 or higher.

- The ice machine will not start an ice making cycle and the display indicates "Full Bin".
- The ice machine displays "Full Bin Remove Ice" in the clean cycle.

E Control Boards with firmware versions prior to Rev.2.047

- The ice machine will not start an ice making cycle and the display indicates "Curtain Open".
- The ice machine will run in the clean cycle.

Bin Switch Fails Closed

- When running a "Long Harvest" alert is displayed and safety limit 2 indicated.
- May be off on a safety limit 2.
- The harvest cycle continues after ice opens and closes the ice damper (harvest cycle is 3.5 minutes).

DIAGNOSTICS

1. Verify bin switch, curtain/damper and curtain/damper magnet are in place.
 - Press the Menu button.
 - Scroll down to Service and press right arrow.
 - Scroll down to Diagnostics and press right arrow
 - Scroll down to Inputs and press right arrow to display curtain switch readings (Curt SW1, Curt SW2, etc).
2. Open and close the ice damper(s) repeatedly while observing the display and control board lights.
 - A. Curtain switch cycles open/closed and control board light energizes/de-energizes - Bin switch is operating normally
 - B. Curtain switch remains closed and control board light remains on - Go to step 3
 - C. Curtain switch remains open and control board light remains off - Go to step 3
3. Disconnect bin switch wire from control board.
4. Jumper control board bin switch wire to ground, press the power button and observe the display and control board lights.
 - A. Curtain switch closes, control board light energizes and ice machine starts - Replace bin switch
 - B. Curtain switch remains open and control board light is off - Verify procedure was correctly followed - Replace control board.

WATER LEVEL CONTROL CIRCUITRY

FUNCTION

The water level probe controls the water level by sensing whether water is or is not contacting the water level probe. The water level probe has three sensing probes. Two probes are equal in length and are used to measure conductivity for diagnostics, ice clarity and water miser options. Factory default settings measure resistance from both long probes to the short probe.

SPECIFICATIONS

Freeze Cycle Water Level Setting

During the Freeze cycle, the water level probe is set to maintain the proper water level above the water pump housing. The water level is not adjustable. If the water level is incorrect, check the water level probe position. Reposition or clean the probe as necessary.

Water Inlet Valve Safety Shut-Off

In the event of a water level probe failure, this feature limits the maximum amount of time the water inlet valve can remain.

SINGLE EVAPORATOR MODELS

Regardless of the water level probe input, the control board automatically shuts off the water inlet valve if it remains on for 12.5 continuous minutes (30 seconds in prechill and two 6 minute periods in the freeze cycle).

DUAL EVAPORATOR MODELS

Regardless of the water level probe input, the control board automatically shuts off the water inlet valve if it remains on for 16.5 continuous minutes (30 seconds in prechill and two 8 minute periods in the freeze cycle).

Prechill & Freeze Cycle Operation

The water inlet valve energizes and de-energizes in conjunction with the water level probe located in the water trough.

- The water inlet valve is ON when there is no water in contact with the water level probes.
- The water inlet valve turns OFF after water contacts the water level probes for 6 continuous seconds.
- The water inlet valve can cycle ON and OFF once in the prechill and up to two times in the freeze cycle.
- Maximum fill time is:
Single evaporator 12.5 minutes
Dual evaporator 16.5 minutes

The water inlet valve energizes in the Prechill cycle and will de-energize if water touches the high level probe (in most instances the water trough can't fill in the prechill cycle and the water inlet valve will remain energized into the freeze cycle). The water inlet valve will remain energized until water contacts the high water probe. The water inlet valve will cycle ON, and then OFF one more time to refill the water trough. The water inlet valve is now OFF for the duration of the freeze cycle.

Diagnostics

SYMPTOMS

- Water trough overfills
- Water trough will not fill

NOTE: The ice machine will initiate a premature harvest if the high water level probe circuit is complete and the low water level probe is open.

WATER TROUGH OVERFILLING DURING THE FREEZE CYCLE

Step 1 Press the power button and turn off the ice machine.

Step 2 If water continues to flow with the ice machine off, disconnect power. If water continues to flow with power disconnected verify water pressure is below 80 psig before replacing the water inlet valve. If the water stops continue with step 2.

Step 3 Check water level probe mounting and verify secure wiring connections at the probe and control board.

Step 4 Scroll to Service/Diagnostics/Inputs and press down arrow until Wtr Low and Wtr High are displayed.

- No is displayed on both Wtr low and Wtr high - The control board is not receiving a sensing water signal - Go to next step.
- Yes is displayed - The control board is receiving a sensing water signal from the low and high probes - Clean the water level probe and test run.

Step 5 Disconnect the water level probe wiring harness from the control board and ohm harness and water level probe. Normal readings will show no resistance.

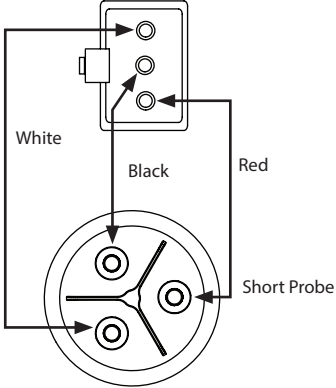

Ohm water Level Probe and Wiring Harness

Step 6 When all ohm tests are normal, replace the control board. When any measurement fails, disconnect the wiring harness from the water level probe and ohm the water level probe with the wiring harness removed from the circuit. Results will determine whether the wiring harness or probe will need replacement.

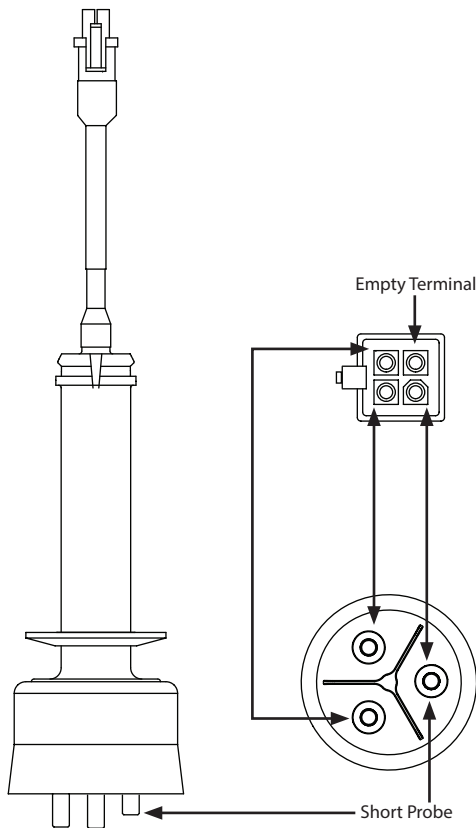

Ohm Water Level Probe

WATER TROUGH WILL NOT FILL

Step 1 Verify water is supplied to the ice machine.

Step 2 Scroll to Service/Diagnostics/Inputs and press down arrow until Wtr Low and Wtr High are displayed.

- A. Yes is displayed - Control board is receiving a sensing water signal. Proceed to step 3.
- B. No is displayed - Control board is not receiving a sensing water signal. Proceed to Control Board Diagnostics page 156.

Step 3 Disconnect water level probe, observe LCD display text.

- A. No is displayed - Clean the water level probe and test interconnecting wiring.
- B. Yes is displayed - Refer to Control Board Diagnostics page 156

Step 4 Ohm probe - Refer to previous page for procedure.

WATER LEVEL PROBE CIRCUIT CHECK AT CONTROL BOARD

Wait until prechill cycle starts, then jumper water level probe connections (2 & 3) on the control board.

- A. Wtr High displays yes and the water stops. Repair wire or replace water level probe.
- B. Wtr High displays No and the water continues to flow. Replace control board.

ICE THICKNESS PROBE (INITIATES HARVEST)

FUNCTION

The ice thickness probe senses ice on the evaporator and signals the control board to start a harvest cycle.

SPECIFICATIONS

Freeze Time Lock-In Feature

The ice machine control system incorporates a 6 minute freeze time lock-in feature. This prevents the ice machine from short cycling in and out of harvest.

Maximum Freeze Time

The maximum freeze time is 35 minutes at which time the control board automatically initiates a harvest sequence. Firmware 5.009 or earlier - Maximum freeze time is 60 minutes at which time the control board automatically initiates a harvest sequence.

Maximum Temperature

Maximum temperature for the ice thickness probe is 120°F (49°C). Do not clean probe in a dishwasher or expose to temperatures above the maximum.

Ice Thickness Check

The ice thickness probe is factory-set to maintain the ice bridge thickness at 1/8 in. (3 mm).

NOTE: Make sure the water curtain/splash shields are in place when performing this check. It prevents water from splashing out of the water trough. Remove the curtain to make an adjustment, then replace immediately after the adjustment is made.

1. Inspect the bridge connecting the cubes. It should be about 1/8 in. (3 mm) thick.
2. If adjustment is necessary, turn the ice thickness probe adjustment screw clockwise to increase bridge thickness or counterclockwise to decrease bridge thickness. Set a 9/32" gap between the flat of the ice thickness probe and evaporator as a starting point. Then adjust to achieve 1/8" ice thickness.
3. Make sure the ice thickness probe wire and the bracket do not restrict movement of the probe.

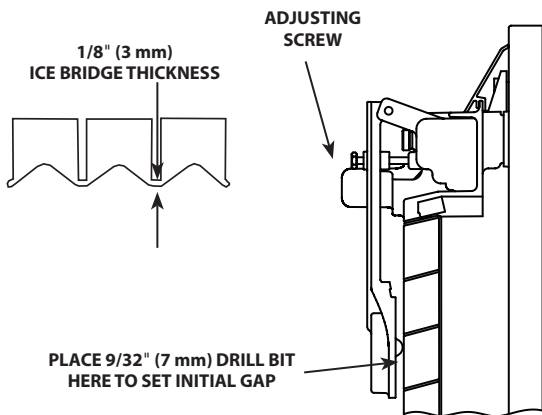

Ice Thickness Adjustment

Ice Machine Doesn't Harvest Properly

ICE MACHINE CYCLES INTO HARVEST PREMATURELY

OR

ICE MACHINE DOES NOT CYCLE INTO HARVEST

Symptoms

- Low ice production
- Thin or thick ice in bin
- Freeze cycles are faster or longer than published cycle times
- Large sheet of ice on evaporator

Diagnostics

1. Remove all ice from the evaporator when present.
2. Press the power button and turn off the ice machine.
3. Disconnect power to the ice machine at the main disconnect.
4. Inspect the ice thickness probe for physical damage. On the face of the probe look for bulging, cracks around the nipple and deformed pivot pins or pivot pin arms.
5. Verify the ice thickness probe gap is approximately 9/32" (7 mm). See "Ice Thickness Probe (Initiates Harvest)" on page 173.
6. Make sure the ice thickness probe wire and the bracket do not restrict movement of the probe.
7. Reapply power to the ice machine at the main disconnect and confirm the ice machine is off.
8. Press the menu button, scroll down to Service, press the right arrow, scroll down to Real Time Data, press right arrow - With the brackets around Time & Temp press the right arrow - Scroll down until 100Hz & 120Hz are displayed.

9. Observe the initial number range and perform a scratch test.
 - Remove the water curtain or splash shield if present.
 - Lift the ice thickness probe and carefully scratch the nipple on the face of the probe for at least 10 seconds.

The initial numbers displayed are constantly changing and are less than 3000.

- If the numbers increase by 3000 or more above the initial reading, begin the “Harvest Test” on page 177.

Example: Initial reading is 300 - A scratch test reading of 3300 or higher indicates a good ice thickness probe.

The initial numbers displayed do not change or initial numbers did not increase by 3000 during scratch test.

- Verify the ice thickness probe connector is properly plugged into the board (J11) and the ice thickness probe wiring is correct. If the wiring is incorrect replace the ice thickness probe.

J11 Connector On Control Board	
Pin 1 (+)	Red
Pin 2 (-)	Black
Pin 3	Twisted Wire

10. Unplug the ice thickness probe and set a VOM to DC voltage scale - Measure voltage across Pin 1 (+) Red Wire and Pin 2 (-) Black Wire.
 - A. Voltage measures 3.25 to 3.35 VDC.
Replace ice thickness probe.
 - B. Voltage does not measure 3.25 to 3.35 VDC.
Replace the control board.

Harvest Test

1. Press the power button to start an ice making cycle. Remove water curtain or splash guard when present.
2. Remove the ice thickness probe, rotate and remount with the nipple facing away from the evaporator.
3. Press the Menu button, scroll down to "Service", press the right arrow, scroll down to "RealTimeData", press the right arrow, scroll down to "Inputs", press the right arrow and then scroll down to "Ice Sense".
4. Wait until 6.5 minutes into the freeze cycle (sequence 4. Freeze). Refer to Sequence of Operation starting on page 103 for details.
5. Scratch the ice thickness probe nipple for approximately 30 seconds.

HARVEST CYCLE STARTS AND "ICE SENSE" CHANGES FROM NO TO YES

The ice thickness probe and control board are operating normally.

- Continue with harvest to remove any ice from the evaporator that may have formed during testing.
- Press the power button and turn off the ice machine.
- Remove the ice thickness probe, rotate and remount with the nipple facing the evaporator. Set the ice thickness probe gap to 9/32" (7 mm). Confirm the cable is not twisted or binding and the ice thickness probe swings freely, then re-install the water curtain.
- Perform an "Ice Thickness Check" on page 101 and test run the ice machine 2 cycles.

HARVEST CYCLE DOES NOT START

- If the control board fails to initiate a harvest cycle replace the control board and perform "Ice Thickness Check" on page 101.

HIGH PRESSURE CUTOUT (HPCO) CONTROL

FUNCTION

Stops the ice machine if subjected to excessive high-side pressure. The HPCO control is normally closed, and opens on a rise in discharge pressure.

SPECIFICATIONS

Specifications	
Cut-Out	Cut-In
450 psig \pm 7 (3102 kPa \pm 48 31 bar \pm .48)	300 psig \pm 10 (2068 kPa 20.68 bar)
Automatic Reset	

SYMPTOM

Opening the HPCO will cause the control board to initiate a 60 minute delay. The display counts down from 60 minutes to 0 minutes, at which point the ice machine attempts a restart. If the HPCO is closed the ice machine will continue to run. If the HPCO remains open after the 60 minute delay or reopens when the compressor starts, the ice machine will start another 60 minute delay period.

1. Machine is off and the display indicates "Delay XX min, HPCO Active"
2. Machine is running and the display has an alert triangle - Press left arrow to display "HPC Fault".

CHECK PROCEDURE

Symptom #1 Machine is off and the display indicates “Delay xx min, HPCO Active”.

1. Cycle ice machine with the on/off button. The ice machine will go to an initial start sequence if the HPCO is closed. If the HPCO is open, another 60 minute delay period starts.
 - Ice Machine starts - Run the system to see if the control trips at the rated pressure. If HPCO opens at a pressure significantly lower or higher than the control setting of 450 psig replace the HPCO. If the control opens at the correct pressure find the root cause - Fan motor, dirty condenser, refrigeration system issue, etc.
 - Ice Machine Does Not Start - Continue with the next step.
2. Leave all wiring connectors attached and perform testing within the 60 minute time delay period. Check for 24 volts at terminals V & C (interconnecting wiring connections) on the ice machine control board.
 - A. 24 volts - Proceed with next step
 - B. 0 Volts - Restore line voltage to condensing unit, or repair interconnecting wiring, or replace transformer in condensing unit.
3. Check for 24 volts at terminals C & HPC1.
 - A. 24 volts - Proceed with next step.
 - B. 0 volts - HPCO switch is open. Verify pressure - Below cut-in replace HPCO - Above cut-in find root cause problem.
4. Check for 24 volts at terminals C & HPC2.
 - A. 24 volts - Faulty relay on control board - Replace control board.
 - B. 0 volts - HPCO switch is open. Verify pressure - Below cut-in, replace HPCO - Above cut-in, find root cause problem.

Symptom #2 Machine is running and the display has a flashing alert triangle and indicates “HPC Fault” after the left arrow is pressed

1. Navigate to the event log on the Service menu. Scroll down to HPC Fault EO5. Open the event and view when and how often HPCO Fault has occurred.
2. If this is a one time event it may be intermittent and caused by conditions around the unit changing. For example: High ambient temperature, water turned off to condenser (water cooled unit) etc.
3. Run the system to see if the control trips at the rated pressure. If HPCO opens at a pressure significantly lower than the control setting of 450 psig replace the HPCO.
4. If the control opens at the correct pressure (± 10 lbs) find the root cause - Fan motor, dirty condenser, refrigeration system issue, etc.

LOW PRESSURE CUTOUT (LPCO) CONTROL

FUNCTION

Signals the control board to energize and de-energize the contactor when suction pressure rises above or falls below setpoint.

The LPCO control is closed at pressures above setpoint and opens at pressures below setpoint.

Specifications	
Cut-Out	Cut-In
12 psig \pm 3	35 psig \pm 5

CHECK PROCEDURE

1. Navigate to LPCO input on display
 - Press the Menu button.
 - Scroll down to Service and press right arrow.
 - Scroll down to Diagnostics and press right arrow
 - Scroll down to Inputs and press right arrow to display LPCO reading
2. LPCO display indicates
 - A. Open = Replace Switch
 - B. Closed = Switch OK
3. Connect manifold gauges and verify refrigerant pressure exceeds LPCO cut-in. If pressure exceeds cut-in and the contacts are open, replace the LPCO.

FAN CYCLE CONTROL

FUNCTION

Cycles the fan motor on and off to maintain proper operating discharge pressure.

The fan cycle control closes on an increase, and opens on a decrease in discharge pressure.

SPECIFICATIONS

Specifications		
Model	Cut-In (Close)	Cut-Out (Open)
ICVD0695		
ICVD0696		
ICVD0895		
ICVD0996		
ICVD1095	250 ±5	200 ±5
ICVD1195	(1723 kPa ±.34)	(1517 kPa ±.34)
ICVD1495	(17.23 bar ±.34)	(15.17 bar ±.34)
ICVD1496		
ICVD1895		
ICVD2095		
ICVD2096		

CHECK PROCEDURE

1. Verify fan motor windings are not open or grounded, and fan spins freely.
2. Connect manifold gauges to ice machine.
3. Hook voltmeter in parallel across the fan cycle control, leaving wires attached.
4. Refer to chart below.

FCC Setpoint:	Reading Should Be:	Fan Should Be:
Above Cut-In	0 Volts	Running
Below Cut-Out	Line Voltage	Off

THERMISTORS

FUNCTION

Thermistor resistance values change with temperature. The value supplied to the control board is used to identify temperature at the thermistor location.

SPECIFICATIONS

Temperature of Thermistor		Resistance
°C	°F	K Ohms (x 1000)
-30° - -20°	-22° - -4°	820.85 - 466.35
-20° - -10°	-4° - 14°	466.35 - 269.05
-10° - 0°	14° - 32°	269.05 - 160.70
0° - 10°	32° - 50°	160.70 - 98.930
10° - 20°	50° - 68°	98.930 - 62.015
20° - 30°	68° - 86°	62.015 - 39.695
30° - 40°	86° - 104°	39.695 - 25.070
40° - 50°	104° - 122°	25.070 - 17.481
50° - 60°	122° - 140°	17.481 - 11.860
60° - 70°	140° - 158°	11.860 - 8.1900
70° - 80°	158° - 176°	8.1900 - 5.7530
80° - 90°	176° - 194°	5.7530 - 4.1015
90° - 100°	194° - 212°	4.1015 - 2.9735
100° - 110°	212° - 230°	2.9735 - 2.1885
110° - 120°	230° - 248°	2.1885 - 1.6290
120° - 130°	248° - 266°	1.6290 - 1.2245
130° - 140°	266° - 284°	1.2245 - 0.9319
140° - 150°	284° - 302°	0.9319 - 0.7183
150° - 160°	302° - 320°	0.7183 - 0.5624
160° - 170°	320° - 338°	0.5624 - 0.4448
170° - 180°	338° - 356°	0.4448 - 0.3530
180° - 190°	356° - 374°	0.3530 - 0.2831
190° - 200°	374° - 392°	0.2831 - 0.2273

Thermistor Matrix

TEMPERATURE SENSOR LOCATION							
Ice Machine Description	Evaporator In	Evaporator Out for 1st circuit	Evaporator Out for 2nd circuit or 2nd Evaporator	Compressor Discharge	Condenser Liquid Line	Receiver Inlet	Receiver Outlet
22" & 30" 1 Evaporator with 1 Circuit IMH Air-Cooled & Water-Cooled	T3	T4		T2	T1		
30" & 48" 1 Evaporator with 2 Circuits IMH Air-Cooled & Water-Cooled		T4	T3	T2	T1		
30" 1 Evaporator with 1 Circuit RCU Air-Cooled	T3	T4		T2		T1	
30" & 48" 1 Evaporator with 2 Circuits RCU Air-Cooled		T4	T3	T2		T1	
QuietCube 1 Evaporator with 1 Circuit RCU Air-Cooled	T3	T4				T1	T2
QuietCube 1 Evaporator with 2 Circuits or 2 Evaporators RCU Air-Cooled		T4	T3			T1	T2

SYMPTOM

Alert icon on the display is flashing and the alert indicates a T1, T2, T3, or T4 Fault.

CHECK PROCEDURE

- Press the Menu button.
- Scroll down to Service and press right arrow.
- Scroll down to Diagnostics and press right arrow
- Scroll down to Temp Sensors and press right arrow to display thermistor temperature readings.

NOTE: An open thermistor will display -22°F (-30°C) and a shorted thermistor displays 475°F (246°C).

Thermistor Test

1. Disconnect thermistor from control board and measure resistance.
2. Measure temperature at the thermistor.
3. Compare measured resistance/temperature readings to resistance/temperature relationship chart.
 - A. Within 10% of the published resistance value - Thermistor is good
 - B. Not within 10% of the published resistance value - Thermistor is defective.

Control Board Test

1. Disconnect thermistor from control board - The display temperature reading, dropping to -22°F (-30°C) indicates the control board is good.
2. Short thermistor pins - The display temperature reading, climbing to 475°F (246°C) indicates the control board is good.

HARVEST ASSIST AIR PUMP

FUNCTION

The air pump helps break the vacuum between the sheet of ice and the evaporator which results in shorter harvest cycles.

SPECIFICATIONS

115 Volt or 230 Volt - matches the ice machine voltage.

CHECK PROCEDURE

1. The air pump is wired in parallel with the harvest valve - Verify the ice machine is in the harvest cycle and the harvest valve is energized.
2. If there is voltage at the air pump connector, use a volt ohm meter to verify there is no continuity through the motor windings then replace motor.

COMPRESSOR ELECTRICAL DIAGNOSTICS

The compressor does not start or will trip repeatedly on overload.

Check Resistance (Ohm) Values

NOTE: Compressor windings can have very low ohm values. Use a properly calibrated meter.

Perform the resistance test after the compressor cools. The compressor dome should be cool enough to touch (below 120°F/49°C) to assure that the overload is closed and the resistance readings will be accurate.

SINGLE PHASE COMPRESSORS

1. Disconnect power then remove the wires from the compressor terminals.
2. The resistance values between C and S and between C and R, when added together, should equal the resistance value between S and R.
3. If the overload is open, there will be a resistance reading between S and R, and open readings between C and S and between C and R. Allow the compressor to cool, then check the readings again.

THREE PHASE COMPRESSORS

1. Disconnect power and remove the wires from the compressor terminals.
2. The resistance values between L1 and L2, between L2 and L3, and between L3 and L1 should all be equal.
3. If the overload is open, there will be open readings between L1 and L2, between L2 and L3, and between L3 and L1. Allow the compressor to cool, then check the readings again.

CHECK MOTOR WINDINGS TO GROUND

Check continuity between all three terminals and the compressor shell or copper refrigeration line. Scrape metal surface to get good contact. If continuity is present, the compressor windings are grounded and the compressor should be replaced.

COMPRESSOR DRAWING LOCKED ROTOR

To determine if the compressor is seized, check the amp draw while the compressor is trying to start.

The two likely causes of this are a defective starting component or a mechanically seized compressor.

To determine which you have:

1. Install high and low side gauges.
2. Try to start the compressor.
3. Watch the pressures closely.
 - A. If the pressures do not move, the compressor is seized. Replace the compressor.
 - B. If the pressures move, the compressor is turning slowly and is not seized. Check the capacitors and relay.

COMPRESSOR DRAWING HIGH AMPS

The continuous amperage draw on start-up should not be near the maximum fuse size indicated on the serial tag.

DIAGNOSING START COMPONENTS

If the compressor attempts to start, or hums and trips the overload protector, check the start components before replacing the compressor.

Capacitor

Visual evidence of capacitor failure can include a bulged terminal end or a ruptured membrane. Do not assume a capacitor is good if no visual evidence is present. A good test is to install a known good substitute capacitor. Use a capacitor tester when checking a suspect capacitor. Clip the bleed resistor off the capacitor terminals before testing.

Relay

The relay has a set of contacts that connect and disconnect the start capacitor from the compressor start winding. The contacts on the relay are normally closed (start capacitor in series with the start winding). The relay senses the voltage generated by the start winding and opens the contacts as the compressor motor starts. The contacts remain open until the compressor is de-energized.

RELAY OPERATION CHECK

1. Disconnect wires from relay terminals.
2. Verify the contacts are closed.
Measure the resistance between terminals 1 and 2. No continuity indicates open contacts. Replace the relay.
3. Check the relay coil.
Measure the resistance between terminals 2 and 5. No resistance indicates an open coil. Replace the relay.

PTCR

The PTCR allows current to flow through the start winding at compressor startup. Current flow heats the ceramic discs in the PTCR. The electrical resistance increases with temperature and stops all except a trickle of current flow through the start winding. The small flow of current keeps the PTCR hot (260°F/127°C) and the start winding out of the circuit.

The PTCR must be cooled before attempting to start the compressor, otherwise the PTCR will heat up too quickly and stop current flow through the start winding before the compressor motor reaches full speed.

Warning

Disconnect electrical power to the entire ice machine at the building electrical disconnect box before proceeding.

NOTE: If a PTCR is dropped internal damage can occur to the ceramic PTCR discs. The ceramic disc can chip and cause arcing which leads to PTCR failure. Since there is no way to open the PTCR in order to determine if the ceramic disc is chipped or not, it must be discarded when dropped.

PTCR Operation Check

1. Visually inspect the PTCR. Check for signs of physical damage.

NOTE: The PTCR case temperature may reach 210°F (100°C) while the compressor is running. This is normal. Do not change a PTCR just because it is hot.

2. Wait at least 10 minutes for the PTCR to cool to room temperature.
3. Remove the PTCR from the ice machine.
4. Measure the resistance of the PTCR as shown. The resistance reading must be between:
 - Two Terminal PTCR Black = 24.5 to 45.5 ohms
 - Two Terminal PTCR Blue = 21 to 39 ohms
 - Three Terminal PTCR Tan = 10.5 to 19.5 ohms.

Measure Resistance At Ends

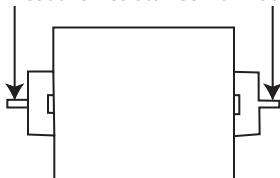

Two Terminal PTCR

Measure Resistance @ Center and End

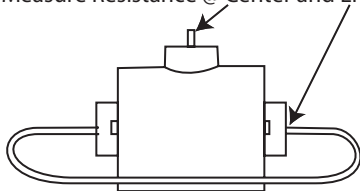

Leave Jumper Wire Attached

Three Terminal PTCR

Refrigeration Components

HEAD PRESSURE CONTROL VALVE

Manitowoc remote systems require head pressure control valves with special settings. Replace defective head pressure control valves only with “original” Manitowoc replacement parts.

Refrigerant Charge Verification

The correct amount of refrigerant (name plate charge) is required to operate correctly at all ambient conditions.

An ice machine with an overcharge or undercharge of refrigerant may function properly at higher ambient temperatures and fails at lower ambient temperatures.

Symptoms of incorrect refrigerant amount are:

- Works during the day and malfunctions at night, and/or fails whenever the outdoor temperature drops.
- A safety limit is stored in control board memory.

Refrigerant loss and ambient temperature are directly related to each other. As the ambient temperature drops, more refrigerant is stored in the condenser.

When the refrigerant charge and ambient temperature create an undercharge of refrigerant in the freeze cycle, the receiver dip tube will lose its liquid seal. Without liquid refrigerant to the TXV, the ice machine fails to make a full sheet of ice in 60 minutes and a safety limit #1 results.

NOTE: When a head pressure control valve is being replaced or refrigerant charge is suspected, verify the refrigerant charge is correct by recovering the refrigerant, weighing and comparing to the nameplate amount. Refer to “Recovery/Evacuation Procedures” for recovery procedures.

Freeze Cycle Operation All Models

The R404A head pressure control valve is non adjustable.

At ambient temperatures of approximately 70°F (21°C) or above, refrigerant flows through the valve from the condenser to the receiver inlet. At temperatures below this (or at higher temperatures if it is raining), the head pressure control dome's nitrogen charge closes the condenser port and opens the bypass port from the compressor discharge line.

In this modulating mode, the valve maintains minimum head pressure by building up liquid in the condenser and bypassing discharge gas directly to the receiver.

Harvest Cycle Operation

During the Harvest cycle, the harvest valve opens and allows refrigerant from the top of the receiver tank to enter the evaporator. The refrigerants change of state (from vapor to liquid) releases the heat necessary for the Harvest cycle.

Opening the harvest valve causes a drop in discharge pressure.

The discharge pressure will drop below the condenser fan cycling control setpoint and the condenser fan motor cycles off (at ambient temperatures above 110°F (43°C) the condenser fan motor remains energized).

The warm discharge gas adds heat to the receiver in the harvest cycle. Without this additional heat the head pressure would continue to drop as liquid refrigerant boils off in the receiver.

Example: A service technician removes refrigerant vapor from a cylinder by boiling off the liquid refrigerant. A refrigeration effect is created as the refrigerant changes state from a liquid to a vapor. The cylinder cools and the refrigerant pressure drops. To maximize flow and maintain pressure the technician places the cylinder in warm water.

Diagnostics

FREEZE CYCLE - QUIETQUBE® REMOTE

CONDENSING UNIT

1. Determine if the coil is clean.
2. Determine the air temperature entering the condenser.
3. Determine if the head pressure is high or low in relationship to the outside temperature. (Refer to the proper "Cycle Times/24-Hour Ice Production/Refrigerant Pressure Charts" page 211).
4. Determine the temperature of the liquid line entering the receiver by feeling it. This line is normally warm; "body temperature."
5. Using the information gathered, refer to the chart.

NOTE: A head pressure control valve that will not bypass, will function properly with condenser air temperatures of approximately 70°F (21°C) or above. When the temperature drops below 70°F (21°C), the head pressure control valve fails to bypass and the ice machine malfunctions. Lower ambient conditions can be simulated by rinsing the condenser with cool water during the freeze cycle.

Condition	Probable Cause	Corrective Measure
Discharge Pressure - High Liquid Line Temperature - Hot	Valve stuck in bypass	Replace valve
Discharge Pressure - Low Liquid Line Temperature - Cold	Valve not bypassing	Replace valve
Discharge Pressure - Low Liquid Line Temperature - Hot	Ice Machine Low on Charge	Refrigerant Charge Verification

Harvest Cycle

QUIETQUBE® REMOTE CONDENSING UNIT

QuietQube® ice machines may fail in the harvest cycle when the refrigerant charge and ambient temperature create a marginal undercharge of refrigerant. The ice machine may be able to make a full sheet of ice, but fails in the harvest cycle when the receiver runs out of liquid refrigerant. A safety limit #2 will result when the ice machine is unable to harvest.

Undercharge Symptoms

- Safety limit #1 or Safety limit #2 in control board memory, a flashing triangle alert and after pressing left arrow Long Freeze or Long Harvest is displayed.
- Harvest cycle suction pressure is low.
- Harvest cycle discharge pressure is low.
- Liquid line entering receiver feels warm to hot in the freeze cycle.

Overcharge Symptoms

- Safety limit #2 in control board memory, a flashing triangle alert and after pressing left arrow Long Harvest is displayed.
- Harvest cycle discharge pressure is normal.
- Freeze cycle time, suction and discharge pressure are normal and the ice machine will not harvest. The sheet of ice cubes show little or no sign of melting when removed from the evaporator after the harvest cycle has been completed. (If the cubes are melted you have a release problem, clean the ice machine).

HARVEST CYCLE DIAGNOSTICS QUIETQUBE® REMOTE CONDENSING UNIT

The headmaster control valve diverts the compressor discharge gas to the ice machine receiver in the harvest cycle. All refrigerant flow through the condenser in the harvest cycle stops. Symptoms of a headmaster valve that will not seat 100% closed (completely bypass the condenser) in the harvest cycle are:

- Freeze cycle suction and discharge pressure are normal.
- The control board indicates safety limit #2, a flashing triangle alert and after pressing left arrow Long Harvest is displayed. The failure seems to be temperature related. Example: The ice machine may function correctly at temperatures above 32°F but fails at temperatures below 32°F.
- Harvest cycle suction pressure is low.
- Harvest cycle discharge pressure is normal or slightly low.

Procedure

1. Freeze cycle operation must be normal before diagnosing the headmaster in the harvest cycle. (Refer to Cycle Times/24 hr Ice Production/Refrigerant Pressure Chart)
2. Allow the ice machine to run a normal freeze cycle (do not initiate an early harvest cycle).
3. At the start of the harvest cycle feel the compressor discharge line and the liquid line to the ice machine receiver at the headmaster valve. The temperature of both lines will be highest at the beginning of the harvest cycle and then decrease. Compare the lines 30 seconds into the harvest cycle and then refer to Harvest Cycle Headmaster Control Valve Failure List page 195.

Step 3 Details
Grasp Here with Hands to Compare Temperatures

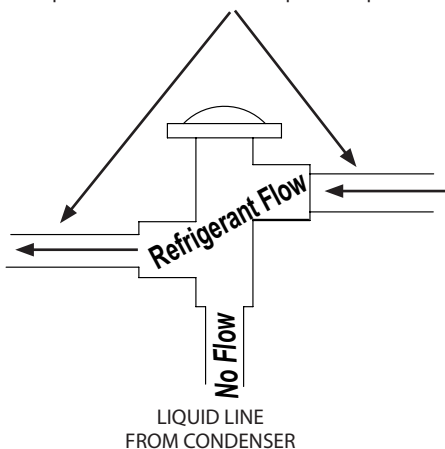

HARVEST CYCLE HEADMASTER CONTROL VALVE FAILURE LIST

Temperature of the compressor discharge line and liquid line to the ice machine receiver feel the same 30 seconds into the harvest cycle.

- The headmaster is functioning correctly.

The compressor discharge line is noticeably warmer than the liquid line to the ice machine receiver.

- Headmaster valve is not bypassing 100%. Replace headmaster valve.

SUCTION ACCUMULATOR OPERATION

Liquid refrigerant collects in the suction accumulator during the harvest cycle and is removed during the freeze cycle. The liquid refrigerant is returned to the compressor through a screen and orifice in the suction accumulator J tube. Passing the liquid through the orifice causes a pressure drop; the liquid flashes to a vapor and creates a refrigeration affect. It is normal to see frost on the accumulator, suction line and compressor suction port in the freeze cycle. The suction accumulator empties within the first 5 minutes of the freeze cycle. When the refrigeration affect ends (liquid refrigerant has been removed), the suction line between the accumulator and compressor will increase in temperature. The suction line temperature increases 20 plus degrees within 2 minutes after the liquid has been removed.

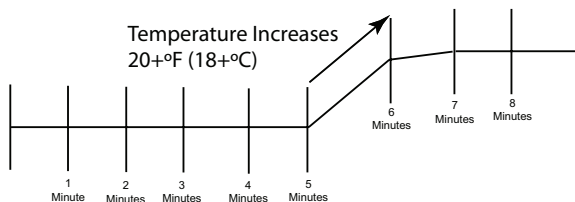

The time needed to remove the liquid refrigerant will vary with the ambient temperature and the length of the harvest cycle. Higher ambient temperatures = shorter harvest cycles, faster removal of liquid refrigerant from the accumulator and greater suction line temperature increases.

Recovery/Evacuation/Charging Procedures QUIETQUBE® MODELS

Do not purge refrigerant to the atmosphere. Capture refrigerant using recovery equipment. Follow the manufacturer's recommendations.

Important

Manitowoc Ice assumes no responsibility for the use of contaminated refrigerant. Damage resulting from the use of contaminated refrigerant is the sole responsibility of the servicing company.

Important

Replace the liquid line drier after recovering the refrigerant and before evacuating and recharging. Use only a Manitowoc (OEM) liquid line filter-drier to prevent voiding the warranty.

⚠ Warning

Recovery/evacuation of a QuietQube® remote system requires connections at either 4 or 5 recovery points for complete system recovery/evacuation. Check valves are located in the ice machine head section and the ICVD condensing unit. Five point requires connections between the compressor and suction filter access valve, receiver access valve and the high and low side access valves on the front or rear of the ice machine. Four point is required on units that do not have a receiver service valve.

⚠ Warning

The receiver access valve (located in the ice machine head section) must be accessed during refrigerant recovery to allow complete removal of the refrigerant charge.

CONNECTIONS

Manifold gauge sets must utilize low loss fittings to comply with U.S. Government rules and regulations.

QuietQube CVD and ICVD condensing units with reciprocating compressors are manufactured with a check valve in the compressor discharge line. The check valve requires an additional connection on the condensing unit during evacuation or recovery procedures. Connection of a manifold gauge set (or a hose with core depressors on both ends) between the suction filter access port and the compressor access valve (located between the compressor and discharge line check valve) is required.

Make these connections:

Ice Machine Head Section	CVD/ICVD Condensing Unit
Receiver Service Valve	Compressor Discharge Access Valve
Low Side Access Valve	Suction Filter Access Valve
High Side Access Valve	

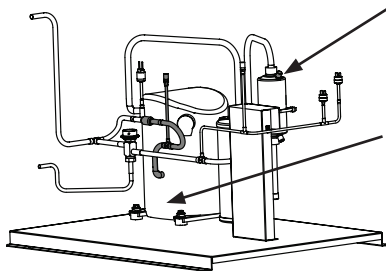

Connections must also be made at two points on condensing unit for complete refrigerant recovery.

RECOVERY/EVACUATION PROCEDURES

1. Press the power button to stop the ice machine. and disconnect all power to the ice machine and condensing unit.
2. Install manifold gauges, charging scale, and recovery unit or two-stage vacuum pump.
3. Open high and low side on the manifold gauge set.
4. Perform recovery or evacuation:
 - A. Recovery: Operate the recovery unit as directed by the manufacturer's instructions.
 - B. Pressure test the system.
 - C. Evacuation prior to recharging: Evacuate to 500 microns. Then allow the pump to run for an additional hour.
5. Refer to Charging Procedures.

CHARGING PROCEDURES

1. The ice machine must be off.
2. Close the vacuum pump valve and the low side manifold gauge valve.
3. Open the refrigerant cylinder and add the proper refrigerant charge (shown on nameplate) into the system high side (receiver service valve and discharge line shut-off valve).
4. If the high side does not take the entire charge, close the high side on the manifold gauge set. Start the ice machine and wait until the freeze cycle starts, then add the remaining charge through valves on back of ice making head, or through valves on suction filter..
5. Disconnect the manifold gauge set from the liquid line shut-off valve.
6. Open the high and low side valves on the manifold gauge set. Any refrigerant in the lines will be pulled into the low side of the system.
7. Allow the pressures to equalize while the ice machine is in the freeze cycle.
8. Disconnect the manifold gauge set from the suction line shut-off valve.
9. Install and torque all valve caps

NOTE: Check for refrigerant leaks after all valve caps have been installed.

System Contamination Clean-Up

General

This section describes the basic requirements for restoring contaminated systems to reliable service.

Important

Routine adjustments and maintenance procedures Manitowoc Ice assumes no responsibility for the use of contaminated refrigerant. Damage resulting from the use of contaminated refrigerant is the sole responsibility of the servicing company.

DETERMINING SEVERITY OF CONTAMINATION

System contamination is generally caused by either moisture or residue from compressor burnout entering the refrigeration system.

Inspection of the refrigerant usually provides the first indication of system contamination. Obvious moisture or an acid odor in the refrigerant indicates contamination.

If either condition is found, or if contamination is suspected, use a Total Test Kit from Totaline or a similar diagnostic tool. These devices sample refrigerant, eliminating the need to take an oil sample. Follow the manufacturer's directions.

If a refrigerant test kit indicates harmful levels of contamination, or if a test kit is not available, inspect the compressor oil.

1. Remove the refrigerant charge from the ice machine.
2. Remove the compressor from the system.
3. Check the odor and appearance of the oil.
4. Inspect open suction and discharge lines at the compressor for burnout deposits.
5. If no signs of contamination are present, perform an acid oil test.

Check the chart on the next page to determine the type of cleanup required.

Contamination Cleanup Chart

Symptoms/Findings	Required Cleanup Procedure
No symptoms or suspicion of contamination	Normal evacuation/recharging procedure
Moisture/Air Contamination symptoms Refrigeration system open to atmosphere for longer than 15 minutes Refrigeration test kit and/or acid oil test shows contamination Leak in water cooled condenser No burnout deposits in open compressor lines	Mild contamination cleanup procedure
Mild Compressor Burnout symptoms Oil appears clean but smells acrid Refrigeration test kit or acid oil test shows harmful acid content No burnout deposits in open compressor lines	Mild contamination cleanup procedure
Severe Compressor Burnout symptoms Oil is discolored, acidic, and smells acrid Burnout deposits found in the compressor, lines, and other components	Severe contamination cleanup procedure

CLEANUP PROCEDURE

Mild System Contamination

1. Replace any failed components.
2. If the compressor is good, change the oil.
3. Replace the liquid line drier.

NOTE: If the contamination is from moisture, use heat lamps during evacuation. Position them at the compressor, condenser and evaporator prior to evacuation. Do not position heat lamps too close to plastic components, or they may melt or warp.

Important

Dry nitrogen is recommended for this procedure. This will prevent CFC release.

4. Follow the normal evacuation procedure, except replace the evacuation step with the following:
 - A. Pull vacuum to 1000 microns. Break the vacuum with dry nitrogen and sweep the system. Pressurize to a minimum of 5 psig (35 kPa, .35 bar).
 - B. Pull vacuum to 500 microns. Break the vacuum with dry nitrogen and sweep the system. Pressurize to a minimum of 5 psig (35 kPa, .35 bar).
 - C. Change the vacuum pump oil.
 - D. Pull vacuum to 500 microns. Run the vacuum pump for 1 hour.

NOTE: You may perform a standing vacuum test to make a preliminary leak check. You should use an electronic leak detector after system charging to be sure there are no leaks.

5. Charge the system with the proper refrigerant to the nameplate charge.
6. Operate the ice machine.

Severe System Contamination

1. Remove the refrigerant charge.
2. Remove the compressor and inspect the refrigeration lines. If burnout deposits are found, install a new harvest valve, replace the manifold strainer, TXV and harvest pressure regulating valve.
3. Wipe away any burnout deposits from suction and discharge lines at compressor.
4. Sweep through the open system with dry nitrogen.

Important

Refrigerant sweeps are not recommended, as they release CFCs into the atmosphere.

5. Install a new compressor and new start components.
6. Install a suction line filter-drier with acid and moisture removal capability. Place the filter drier as close to the compressor as possible.
7. Install an access valve at the inlet of the suction line drier.
8. Install a new liquid line drier (and suction filter on QuietQube® condensing units).

Important

Dry nitrogen is recommended for this procedure. This will prevent CFC release.

9. Follow the normal evacuation procedure, except replace the evacuation step with the following:
 - A. Pull vacuum to 1000 microns. Break the vacuum with dry nitrogen and sweep the system. Pressurize to a minimum of 5 psig (35 kPa, .35 bar).
 - B. Change the vacuum pump oil.
 - C. Pull vacuum to 500 microns. Break the vacuum with dry nitrogen and sweep the system. Pressurize to a minimum of 5 psig (35 kPa, .35 bar).
 - D. Change the vacuum pump oil.
 - E. Pull vacuum to 500 microns. Run the vacuum pump for 1 hour.

NOTE: You may perform a standing vacuum test to make a preliminary leak check. You should use an electronic leak detector after system charging to be sure there are no leaks.

10. Charge the system with the proper refrigerant to the nameplate charge.
11. Operate the ice machine for one hour. Then, check the pressure drop across the suction line filter-drier.
 - A. If the pressure drop is less than 1 psig (7 kPa, .7 bar), the filter-drier should be adequate for complete cleanup.
 - B. If the pressure drop exceeds 1 psig (7 kPa, .7 bar), change the suction line filter-drier and the liquid line drier. Repeat until the pressure drop is acceptable.
12. Operate the ice machine for 48-72 hours. Then remove the suction line drier and change the liquid line drier.
13. Follow normal evacuation procedures.

REPLACING PRESSURE CONTROLS WITHOUT REMOVING REFRIGERANT CHARGE

This procedure reduces repair time and cost. Use it when any of the following components require replacement, and the refrigeration system is operational and leak-free.

- Fan cycle control (air cooled only)
- Water regulating valve (water cooled only)
- High pressure cut-out control
- Low Pressure cut-out control
- High side service valve
- Low side service valve

Important

This is a required in-warranty repair procedure.

1. Disconnect power to the ice machine.
2. Follow all manufacturer's instructions supplied with the pinch-off tool. Position the pinch-off tool around the tubing as far from the pressure control as feasible. (See the figure on next page.) Clamp down on the tubing until the pinch-off is complete.

⚠ Warning

Do not unsolder a defective component. Cut it out of the system. Do not remove the pinch-off tool until the new component is securely in place.

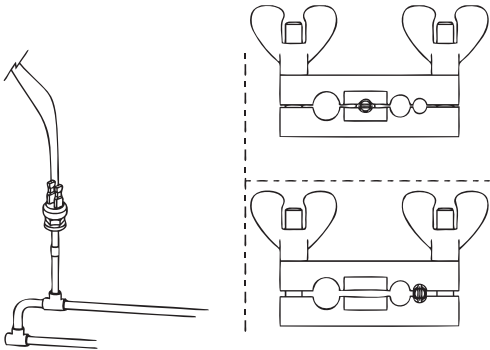

USING PINCH-OFF TOOL

3. Cut the tubing of the defective component with a small tubing cutter.
4. Solder the replacement component in place. Allow the solder joint to cool.
5. Remove the pinch-off tool.
6. Re-round the tubing. Position the flattened tubing in the proper hole in the pinch-off tool. Tighten the wing nuts until the block is tight and the tubing is rounded.

NOTE: The pressure controls will operate normally once the tubing is re-rounded. Tubing may not re-round 100%.

LIQUID LINE FILTER-DRIERS

The filter-driers used on Manitowoc ice machines are manufactured to Manitowoc specifications.

A Manitowoc drier has dirt-retaining filtration, with fiberglass filters on both the inlet and outlet ends. This is very important because ice machines have a back-flushing action that takes place during every Harvest cycle.

The size of the filter-drier is important. The refrigerant charge is critical. Using an improperly sized filter-drier will cause the ice machine to be improperly charged with refrigerant.

Important

Driers are covered as a warranty part. The drier must be replaced any time the system is opened for repairs.

SUCTION FILTER

The suction filter on QuietQube® ICVD condensing units traps particulate only, and do not contain a desiccant. The filter needs replacement when:

1. The pressure drop across the drier exceeds 2 psig.
2. A compressor is replaced.
3. Refrigeration system contains contaminants.

Total System Refrigerant Charge QuietQube® ICVD Models

Model	Condensing Unit	Refrigerant Charge	Line Set Length
I0680C	ICVD0695	10.50 lbs. 4.76kg.	0-50 ft. 0-15 m
		12.00 lbs. 5.54 kg.	51-100 ft. 15-30 m
IB0690C	ICVD0695	11.00 lbs 4.99 kg	0-50 ft. 0-15 m
		12.50 lbs 5.67 kg	51-100 ft. 15-30 m
I0686C	ICVD0696	10.50 lbs. 4.76kg.	0-50 ft. 0-15 m
		12.00 lbs 5.44 kg.	51-100 ft. 15-30 m
IB0696C	ICVD0696	11.00 lbs 4.99 kg	0-50 ft. 0-15 m
		12.50 lbs 5.67 kg	51-100 ft. 15-30 m
I0870C	ICVD0895	8.00 lbs. 3.63 kg.	0-50 ft. 0-15 m
		12.00 lbs. 5.44 kg	51-100 ft. 15-30 m
IB0890C	ICVD0895	8.00 lbs. 3.63 kg	0-50 ft. 0-15 m
	ICVD0996	10.00 lbs. 4.54 kg	51-100 ft. 15-30 m
I0976C	ICVD0895	8.00 lbs. 3.63 kg.	0-50 ft. 0-15 m
		10.00 lbs. 4.54 kg.	51-100 ft. 15-30 m
I1070C	ICVD1095	10.00 lbs. 4.53 kg	0-50 ft. 0-15 m
	ICVD1195	12.00 lbs. 5.44 kg	51-100 ft. 15-30 m
I1176C	ICVD1195	9.00 lbs. 4.09 kg	0-50 ft. 0-15 m
		11 lbs 4.99 kg	51-100 ft. 15-30 m

Model	Condensing Unit	Refrigerant Charge	Line Set Length
IB1090C	ICVD1195	11.50 lbs. 5.22 kg	0-50 ft. 0-15 m
		13.50 lbs 6.16 kg	51-100 ft. 15-30 m
I1470C	ICVD1495 ICVD1496	12.50 lbs. 5.67 kg	0-50 ft. 0-15 m
		14.50 lbs 6.58 kg	51-100 ft. 15-30 m
I1870C	ICVD1895	15.00 lbs. 6.80 kg	0-50 ft. 0-15 m
		17.00 lbs 7.71 kg	51-100 ft. 15-30 m
I2170C	ICVD2095	18.00 lbs. 8.16 kg	0-50 ft. 0-15 m
		22.00 lbs 9.98kg	51-100 ft. 15-30 m
I2176C	ICVD2096	18.00 lbs. 8.16 kg	0-50 ft. 0-15 m
		22.00 lbs 9.98kg	51-100 ft. 15-30 m

NOTE: All machines listed use R-404A refrigerant - This information is for reference only. Refer to the ice machine serial number tag to verify the system charge.

Serial plate information overrides information listed on these pages.

Charts

Cycle Times/24-Hour Ice Production/ Refrigerant Pressure Charts

These charts are used as guidelines to verify correct ice machine operation.

Accurate collection of data is essential to obtain the correct diagnosis.

- Production and cycle times are for dice cube - Half dice cube cycle times can be 2 - 3 minutes faster, depending on model and ambient temperature.
- Regular cube production derate is 7%.
- Ice production checks that are within 10% of the chart are considered normal. This is due to variances in water and air temperature. Actual temperatures will seldom match the chart exactly.
- Refer to "Freeze Cycle Refrigeration System Operational Analysis Tables" page 124 for the list of data that must be collected for refrigeration diagnostics.
- Zero out manifold gauge set before obtaining pressure readings to avoid misdiagnosis.
- Discharge and suction pressure are highest at the beginning of the cycle. Suction pressure will drop throughout the cycle. Verify the pressures are within the range indicated.
- Record beginning of freeze cycle suction pressure one minute after water pump energizes.
- 50 Hz dice and half dice production derate is 12%.
- 50 Hz regular cube total production derate is 14%.

I0680C/ICVD0695

Remote Air-Cooled Condensing Unit Model

Characteristics vary depending on operating conditions.

CYCLE TIMES

Freeze Time + Harvest Time = Total Cycle Time

Air Temp. Entering Condenser °F/°C	Freeze Time			Harvest Time
	Water Temperature °F/°C			
	50/10	70/21	90/32	
-20 to 70/ -29 to 21	8.7-10.0	10.8-12.4	12.3-14.1	.75-2.5
90/32	10.3-11.9	11.6-13.3	12.4-14.3	
100/38	11.0-12.6	12.2-13.9	13.4-15.3	
110/43	12.0-13.8	13.4-15.3	14.9-17.0	

¹Times in minutes - Dice cube

24-HOUR ICE PRODUCTION

Air Temp. Entering Condenser °F/°C	Water Temperature °F/°C		
	50/10	70/21	90/32
-20 to 70/ -29 to 21	650	540	480
90/32	560	505	475
100/38	530	485	445
110/43	490	445	405

¹Based on average ice slab weight of 4.60 - 5.20 lb.

OPERATING PRESSURES

Air Temp. Entering Condenser °F/°C	Freeze Cycle		Harvest Cycle	
	Discharge Pressure psig	Suction Pressure psig	Discharge Pressure psig	Suction Pressure psig
-20 to 50/ -29 to 10	200-250	44-26	180-210	65-85
70/21	235-255	50-28	185-210	65-90
80/27	245-275	50-28	190-210	75-100
90/32	250-290	52-30	195-215	75-105
100/38	270-320	52-31	210-240	80-110
110/43	300-360	60-32	215-260	85-115

IB0690C/ICVD0695

Remote Air-Cooled Condensing Unit Model

Characteristics vary depending on operating conditions.

CYCLE TIMES

Freeze Time + Harvest Time = Total Cycle Time

Air Temp. Entering Condenser °F/°C	Freeze Time			Harvest Time
	Water Temperature °F/°C			
	50/10	70/21	90/32	
-20 to 70/ -29 to 21	9.4-10.8	10.1-11.6	11.0-12.6	.75-2.5
80/27	9.8-11.3	10.7-12.2	11.6-12.3	
90/32	10.2-11.8	11.2-12.9	12.2-13.9	
100/38	10.9-12.5	11.9-13.6	13.1-15.2	
110/43	11.7-13.5	12.9-14.9	14.3-16.3	

¹Times in minutes - Dice cube

24-HOUR ICE PRODUCTION

Air Temp. Entering Condenser °F/°C	Water Temperature °F/°C		
	50/10	70/21	90/32
-20 to 70/ -29 to 21	610	570	530
80/27	585	545	505
90/32	565	520	485
100/38	535	495	455
110/43	500	460	420

¹Based on average ice slab weight of 4.60 - 5.20 lb.

OPERATING PRESSURES

Air Temp. Entering Condenser °F/°C	Freeze Cycle		Harvest Cycle	
	Discharge Pressure psig	Suction Pressure psig	Discharge Pressure psig	Suction Pressure psig
-20 to 50/ -29 to 10	215-260	46-26	140-185	70-95
70/21	220-270	51-26	150-190	70-100
80/27	225-285	56-27	155-195	80-105
90/32	235-295	59-28	165-200	85-105
100/38	260-340	60-30	180-210	85-112
110/43	300-385	65-34	195-230	90-120

I0686C/ICVD0696

Remote Air-Cooled Condensing Unit Model

Characteristics vary depending on operating conditions.

CYCLE TIMES

Freeze Time + Harvest Time = Total Cycle Time

Air Temp. Entering Condenser °F/°C	Freeze Time			Harvest Time
	Water Temperature °F/°C			
	50/10	70/21	90/32	
-20 to 70/ -29 to 21	9.4-10.9	10.2-11.8	11.1-12.8	.75-2.5
80/27	9.9-11.4	10.9-12.5	11.7-13.5	
90/32	10.3-11.9	11.5-13.2	12.4-14.3	
100/38	11.0-12.6	12.2-13.9	13.4-15.3	
110/43	11.9-13.6	12.9-14.8	14.7-16.8	

¹Times in minutes - Dice cube

24-HOUR ICE PRODUCTION

Air Temp. Entering Condenser °F/°C	Water Temperature °F/°C		
	50/10	70/21	90/32
-20 to 70/ -29 to 21	605	565	525
80/27	580	535	500
90/32	560	510	475
100/38	530	485	445
110/43	495	460	410

¹Based on average ice slab weight of 4.60 - 5.20 lb.

OPERATING PRESSURES

Air Temp. Entering Condenser °F/°C	Freeze Cycle		Harvest Cycle	
	Discharge Pressure psig	Suction Pressure psig	Discharge Pressure psig	Suction Pressure psig
-20 to 50/ -29 to 10	200-250	44-26	180-210	65-85
70/21	235-255	50-28	185-210	65-90
80/27	245-275	50-28	190-210	75-100
90/32	250-290	52-30	195-215	75-105
100/38	270-320	52-31	210-240	80-110
110/43	300-360	60-32	215-260	85-115

IB0696C/ICVD0696

Remote Air-Cooled Condensing Unit Model

Characteristics vary depending on operating conditions.

CYCLE TIMES

Freeze Time + Harvest Time = Total Cycle Time

Air Temp. Entering Condenser °F/°C	Freeze Time			Harvest Time
	Water Temperature °F/°C			
	50/10	70/21	90/32	
-20 to 70/ -29 to 21	8.9-10.2	9.5-11.0	10.3-11.9	.75-2.5
80/27	9.3-10.7	10.0-11.5	10.9-12.5	
90/32	9.6-11.1	10.4-12.0	11.4-13.0	
100/38	10.2-11.8	11.1-12.8	12.2-13.9	
110/43	11.0-12.6	12.0-13.8	13.2-15.1	

¹Times in minutes - Dice cube

24-HOUR ICE PRODUCTION

Air Temp. Entering Condenser °F/°C	Water Temperature °F/°C		
	50/10	70/21	90/32
-20 to 70/ -29 to 21	640	600	560
80/27	615	575	535
90/32	595	555	515
100/38	565	525	485
110/43	530	490	450

¹Based on average ice slab weight of 4.60 - 5.20 lb.

OPERATING PRESSURES

Air Temp. Entering Condenser °F/°C	Freeze Cycle		Harvest Cycle	
	Discharge Pressure psig	Suction Pressure psig	Discharge Pressure psig	Suction Pressure psig
-20 to 50/ -29 to 10	215-260	46-26	140-185	70-95
70/21	220-270	51-26	150-190	70-100
80/27	225-285	56-27	155-195	80-105
90/32	235-295	59-28	165-200	85-105
100/38	260-340	60-30	180-210	85-112
110/43	300-385	65-34	195-230	90-120

I0870C/ICVD0895

Remote Air-Cooled Condensing Unit Model

Characteristics vary depending on operating conditions.

CYCLE TIMES

Freeze Time + Harvest Time = Total Cycle Time

Air Temp. Entering Condenser °F/°C	Freeze Time			Harvest Time
	Water Temperature °F/°C			
	50/10	70/21	90/32	
-20 to 70/ -29 to 21	11.0-12.6	12.1-13.8	13.4-15.4	.75-2.5
90/32	12.5-14.4	12.8-14.6	14.9-17.0	
100/38	13.6-15.5	14.7-16.9	15.9-18.2	
110/43	14.9-16.9	15.8-18.0	16.9-19.3	

¹Times in minutes - Dice cube

24-HOUR ICE PRODUCTION

Air Temp. Entering Condenser °F/°C	Water Temperature °F/°C		
	50/10	70/21	90/32
-20 to 70/ -29 to 21	665	610	555
90/32	590	580	505
100/38	550	510	475
110/43	510	480	450

¹Based on average ice slab weight of 5.75 - 6.50 lb.

OPERATING PRESSURES

Air Temp. Entering Condenser °F/°C	Freeze Cycle		Harvest Cycle	
	Discharge Pressure psig	Suction Pressure psig	Discharge Pressure psig	Suction Pressure psig
-20 to 50/ -29 to 10	200-250	50-30	170-200	65-75
70/21	250-290	55-30	180-210	75-95
80/27	260-300	60-31	190-220	75-95
90/32	270-310	60-33	200-230	80-100
100/38	300-380	80-34	210-250	90-110
110/43	310-390	80-35	220-260	105-130

IB0890C/ICVD0895

Remote Air-Cooled Condensing Unit Model

Characteristics vary depending on operating conditions.

CYCLE TIMES

Freeze Time + Harvest Time = Total Cycle Time

Air Temp. Entering Condenser °F/°C	Freeze Time			Harvest Time
	Water Temperature °F/°C			
	50/10	70/21	90/32	
-20 to 70/ -29 to 21	8.5-9.8	9.3-10.7	10.0-11.5	.75-2.5
90/32	9.5-11.0	10.8-12.4	11.4-13.1	
100/38	11.2-12.9	12.3-14.1	13.3-15.2	
110/43	13.0-14.9	14.0-16.0	14.9-17.0	

¹Times in minutes - Dice cube

24-HOUR ICE PRODUCTION

Air Temp. Entering Condenser °F/°C	Water Temperature °F/°C		
	50/10	70/21	90/32
-20 to 70/ -29 to 21	825	770	720
90/32	750	675	640
100/38	650	600	560
110/43	570	535	505

¹Based on average ice slab weight of 5.75 - 6.50 lb.

OPERATING PRESSURES

Air Temp. Entering Condenser °F/°C	Freeze Cycle		Harvest Cycle	
	Discharge Pressure psig	Suction Pressure psig	Discharge Pressure psig	Suction Pressure psig
-20 to 50/ -29 to 10	230-260	45-25	180-205	60-80
70/21	250-275	55-30	180-205	75-105
80/27	260-290	60-31	185-215	80-110
90/32	265-300	60-32	190-220	80-110
100/38	300-370	70-34	200-250	90-115
110/43	310-385	75-35	230-260	95-115

I0976C/ICVD0996

Remote Air-Cooled Condensing Unit Model

Characteristics vary depending on operating conditions.

CYCLE TIMES

Freeze Time + Harvest Time = Total Cycle Time

Air Temp. Entering Condenser °F/°C	Freeze Time			Harvest Time
	Water Temperature °F/°C			
	50/10	70/21	90/32	
-20 to 70/ -29 to 21	8.9-10.3	9.4-14.4	10.1-11.6	.75-2.5
90/32	9.8-11.3	10.4-12.0	11.2-12.9	
100/38	11.0-12.7	11.9-13.6	12.8-14.6	
110/43	12.5-14.4	13.4-15.4	14.3-16.3	

¹Times in minutes - Dice cube

24-HOUR ICE PRODUCTION

Air Temp. Entering Condenser °F/°C	Water Temperature °F/°C		
	50/10	70/21	90/32
-20 to 70/ -29 to 21	795	760	715
90/32	730	695	650
100/38	660	620	580
110/43	590	555	525

¹Based on average ice slab weight of 5.75 - 6.50 lb.

OPERATING PRESSURES

Air Temp. Entering Condenser °F/°C	Freeze Cycle		Harvest Cycle	
	Discharge Pressure psig	Suction Pressure psig	Discharge Pressure psig	Suction Pressure psig
-20 to 50/ -29 to 10	230-260	45-25	180-205	60-80
70/21	250-275	50-30	180-205	75-105
80/27	260-290	55-31	185-215	80-110
90/32	265-300	60-32	190-220	80-110
100/38	300-370	70-34	200-250	90-115
110/43	310-385	75-35	230-260	95-115

I1070C/ICVD1095

Remote Air-Cooled Condensing Unit Model

Characteristics vary depending on operating conditions.

CYCLE TIMES

Freeze Time + Harvest Time = Total Cycle Time

Air Temp. Entering Condenser °F/°C	Freeze Time			Harvest Time
	Water Temperature °F/°C			
	50/10	70/21	90/32	
-20 to 70/ -29 to 21	7.9-9.4	9.7-11.5	11.1-13.1	.75-2.5
80/27	8.4-10.0	10.2-12.1	11.6-13.7	
90/32	8.9-10.6	10.8-12.8	12.3-14.6	
100/38	9.5-11.3	11.4-13.5	13.1-15.5	
110/43	9.9-11.8	12.0-14.2	13.9-16.4	

¹Times in minutes - Dice cube

24-HOUR ICE PRODUCTION

Air Temp. Entering Condenser °F/°C	Water Temperature °F/°C		
	50/10	70/21	90/32
-20 to 70/ -29 to 21	950	800	710
80/27	900	760	680
90/32	860	725	645
100/38	810	690	610
110/43	780	660	580

¹Based on average ice slab weight of 6.2 - 7.2 lb.

OPERATING PRESSURES

Air Temp. Entering Condenser °F/°C	Freeze Cycle		Harvest Cycle	
	Discharge Pressure psig	Suction Pressure psig	Discharge Pressure psig	Suction Pressure psig
-20 to 50/ -29 to 10	200-250	40-30	155-180	70-85
70/21	230-255	50-30	155-180	70-90
80/27	235-260	50-30	155-180	70-95
90/32	240-290	55-31	155-180	85-105
100/38	275-345	60-32	160-200	90-115
110/43	310-380	65-32	160-210	100-120

I1070C/ICVD1195

Remote Air-Cooled Condensing Unit Model

Characteristics vary depending on operating conditions.

CYCLE TIMES

Freeze Time + Harvest Time = Total Cycle Time

Air Temp. Entering Condenser °F/°C	Freeze Time			Harvest Time
	Water Temperature °F/°C			
	50/10	70/21	90/32	
-20 to 70/ -29 to 21	8.7-10.3	9.3-11.1	10.4-12.3	.75-2.5
80/27	9.3-11.1	9.9-11.7	10.9-12.9	
90/32	9.9-11.7	10.3-12.2	11.5-13.6	
100/38	10.6-12.6	10.9-12.9	12.2-14.5	
110/43	11.2-12.6	11.4-13.5	13.3-15.6	

¹Times in minutes - Dice cube

24-HOUR ICE PRODUCTION

Air Temp. Entering Condenser °F/°C	Water Temperature °F/°C		
	50/10	70/21	90/32
-20 to 70/ -29 to 21	875	825	750
80/27	825	785	720
90/32	785	755	685
100/38	735	720	650
110/43	705	690	605

¹Based on average ice slab weight of 6.2 - 7.2 lb.

OPERATING PRESSURES

Air Temp. Entering Condenser °F/°C	Freeze Cycle		Harvest Cycle	
	Discharge Pressure psig	Suction Pressure psig	Discharge Pressure psig	Suction Pressure psig
-20 to 50/ -29 to 10	200-250	40-30	155-180	70-85
70/21	220-255	50-30	155-180	70-90
80/27	230-260	50-30	155-180	70-95
90/32	240-290	55-31	155-180	75-105
100/38	275-345	60-32	160-200	90-115
110/43	310-380	65-32	160-210	100-120

I1076C/ICVD1195

Remote Air-Cooled Condensing Unit Model

Characteristics vary depending on operating conditions.

CYCLE TIMES

Freeze Time + Harvest Time = Total Cycle Time

Air Temp. Entering Condenser °F/°C	Freeze Time			Harvest Time
	Water Temperature °F/°C			
	50/10	70/21	90/32	
-20 to 70/ -29 to 21	7.3-8.7	7.8-9.2	8.5-10.1	.75-2.5
80/27	7.8-9.2	8.2-9.7	8.4-10.0	
90/32	8.2-9.7	8.6-10.3	9.5-11.3	
100/38	9.7-11.5	9.9-11.8	11.3-13.3	
110/43	10.1-12.0	10.4-12.3	12.5-14.7	

¹Times in minutes - Dice cube

24-HOUR ICE PRODUCTION

Air Temp. Entering Condenser °F/°C	Water Temperature °F/°C		
	50/10	70/21	90/32
-20 to 70/ -29 to 21	1015	965	890
80/27	965	925	905
90/32	925	880	810
100/38	800	780	700
110/43	770	750	640

¹Based on average ice slab weight of 6.2 - 7.2 lb.

OPERATING PRESSURES

Air Temp. Entering Condenser °F/°C	Freeze Cycle		Harvest Cycle	
	Discharge Pressure psig	Suction Pressure psig	Discharge Pressure psig	Suction Pressure psig
-20 to 50/ -29 to 10	200-250	40-30	155-180	70-85
70/21	220-255	50-30	155-180	70-90
80/27	230-260	50-30	155-180	70-95
90/32	240-290	55-31	155-180	75-105
100/38	275-345	60-32	160-200	90-115
110/43	310-380	65-32	160-210	100-120

I1176C/ICVD1195

Remote Air-Cooled Condensing Unit Model

Characteristics vary depending on operating conditions.

CYCLE TIMES

Freeze Time + Harvest Time = Total Cycle Time

Air Temp. Entering Condenser °F/°C	Freeze Time			Harvest Time
	Water Temperature °F/°C			
	50/10	70/21	90/32	
-20 to 70/ -29 to 21	7.3-8.7	7.8-9.2	8.5-10.1	.75-2.5
80/27	7.8-9.2	8.2-9.7	8.4-10.0	
90/32	8.2-9.7	8.6-10.3	9.5-11.3	
100/38	9.7-11.5	9.9-11.8	11.3-13.3	
110/43	10.1-12.0	10.4-12.3	12.5-14.7	

¹Times in minutes - Dice cube

24-HOUR ICE PRODUCTION

Air Temp. Entering Condenser °F/°C	Water Temperature °F/°C		
	50/10	70/21	90/32
-20 to 70/ -29 to 21	1015	965	890
80/27	965	925	905
90/32	925	880	810
100/38	800	780	700
110/43	770	750	640

¹Based on average ice slab weight of 6.2 - 7.2 lb.

OPERATING PRESSURES

Air Temp. Entering Condenser °F/°C	Freeze Cycle		Harvest Cycle	
	Discharge Pressure psig	Suction Pressure psig	Discharge Pressure psig	Suction Pressure psig
-20 to 50/ -29 to 10	200-250	40-30	155-180	70-85
70/21	220-265	50-30	155-180	70-90
80/27	230-270	50-30	155-180	70-95
90/32	240-290	55-31	155-180	75-105
100/38	275-335	60-32	160-200	90-115
110/43	310-375	65-32	160-210	100-120

IB1090C/ICVD1195

Remote Air-Cooled Condensing Unit Model

Characteristics vary depending on operating conditions.

CYCLE TIMES

Freeze Time + Harvest Time = Total Cycle Time

Air Temp. Entering Condenser °F/°C	Freeze Time			Harvest Time
	Water Temperature °F/°C			
	50/10	70/21	90/32	
-20 to 70/ -29 to 21	9.3-10.7	10.1-11.7	11.1-12.7	.75-2.5
80/27	10.1-11.7	11.1-12.7	11.8-13.6	
90/32	10.9-12.6	12.2-14.0	12.7-14.6	
100/38	12.0-13.8	12.9-14.8	13.7-15.7	
110/43	13.1-15.0	13.9-16.0	14.9-17.1	

¹Times in minutes - Dice cube

24-HOUR ICE PRODUCTION

Air Temp. Entering Condenser °F/°C	Water Temperature °F/°C		
	50/10	70/21	90/32
-20 to 70/ -29 to 21	1000	930	860
80/27	930	860	810
90/32	870	790	760
100/38	800	750	710
110/43	740	700	660

¹Based on average ice slab weight of 7.5 - 8.5 lb.

OPERATING PRESSURES

Air Temp. Entering Condenser °F/°C	Freeze Cycle		Harvest Cycle	
	Discharge Pressure psig	Suction Pressure psig	Discharge Pressure psig	Suction Pressure psig
-20 to 50/ -29 to 10	200-250	40-25	140-170	65-75
70/21	220-270	40-25	150-185	65-85
80/27	225-275	50-26	160-190	70-90
90/32	235-275	60-27	175-195	75-95
100/38	260-325	65-30	190-220	80-100
110/43	300-360	70-33	200-230	90-105

I1470C/ICVD1495

Remote Air-Cooled Condensing Unit Model

Characteristics vary depending on operating conditions.

CYCLE TIMES

Freeze Time + Harvest Time = Total Cycle Time

Air Temp. Entering Condenser °F/°C	Freeze Time			Harvest Time
	Water Temperature °F/°C			
	50/10	70/21	90/32	
-20 to 70/ -29 to 21	11.5-13.7	12.5-14.8	14.5-17.2	.75-2.5
80/27	13.0-15.4	14.0-16.6	16.3-19.3	
90/32	14.1-16.7	16.1-19.1	17.5-20.7	
100/38	15.0-17.8	17.3-20.4	18.7-22.1	
110/43	11.5-13.7	12.5-14.8	14.5-17.2	

¹Times in minutes - Dice cube

24-HOUR ICE PRODUCTION

Air Temp. Entering Condenser °F/°C	Water Temperature °F/°C		
	50/10	70/21	90/32
-20 to 70/ -29 to 21	1330	1235	1080
90/32	1190	1115	970
100/38	1110	980	910
110/43	1045	920	855

¹Ice slab weight of one harvest cycle = 12.0 lb. to 14.0 lb.
6.0 to 7.0 lbs per evaporator
5.44 kg to 6.35 kg (2.72 to 3.18 kg per evaporator)
230/50/1 is approximately 12% lower than 230/60/1.

OPERATING PRESSURES

Air Temp. Entering Condenser °F/°C	Freeze Cycle		Harvest Cycle	
	Discharge Pressure psig	Suction Pressure psig	Discharge Pressure psig	Suction Pressure psig
-20 to 50/ -29 to 10	250-235	50-36	140-165	70-95
70/21	250-235	55-38	150-170	70-95
80/27	275-240	60-38	160-180	85-95
90/32	300-285	65-39	170-190	90-110
100/38	350-300	70-40	180-200	95-115
110/43	410-350	80-40	190-215	100-125

I1470C/ICVD1496

Remote Air-Cooled Condensing Unit Model

Characteristics vary depending on operating conditions.

CYCLE TIMES

Freeze Time + Harvest Time = Total Cycle Time

Air Temp. Entering Condenser °F/°C	Freeze Time			Harvest Time
	Water Temperature °F/°C			
	50/10	70/21	90/32	
-20 to 70/ -29 to 21	11.3-13.4	12.3-14.6	14.2-16.8	.75-2.5
90/32	12.8-15.2	13.7-16.3	16.0-18.9	
100/38	13.8-16.3	15.8-18.7	17.1-20.2	
110/43	14.7-17.4	16.9-19.9	18.2-21.5	

¹Times in minutes - Dice cube

24-HOUR ICE PRODUCTION

Air Temp. Entering Condenser °F/°C	Water Temperature °F/°C		
	50/10	70/21	90/32
-20 to 70/ -29 to 21	1350	1255	1100
90/32	1210	1135	990
100/38	1130	1000	930
110/43	1065	940	875

¹Ice slab weight of one harvest cycle = 12.0 lb. to 14.0 lb.
6.0 to 7.0 lbs per evaporator
5.44 kg to 6.35 kg (2.72 to 3.18 kg per evaporator)
230/50/1 is approximately 12% lower than 230/60/1.

OPERATING PRESSURES

Air Temp. Entering Condenser °F/°C	Freeze Cycle		Harvest Cycle	
	Discharge Pressure psig	Suction Pressure psig	Discharge Pressure psig	Suction Pressure psig
-20 to 50/ -29 to 10	250-235	50-36	140-165	70-95
70/21	250-235	55-38	150-170	70-95
80/27	275-240	60-38	160-180	85-95
90/32	300-285	65-39	170-190	90-110
100/38	350-300	70-40	180-200	95-115
110/43	410-350	80-40	190-215	100-125

I1870C/ICVD1895

Remote Air-Cooled Condensing Unit Model

Characteristics vary depending on operating conditions.

CYCLE TIMES

Freeze Time + Harvest Time = Total Cycle Time

Air Temp. Entering Condenser °F/°C	Freeze Time			Harvest Time
	Water Temperature °F/°C			
	50/10	70/21	90/32	
-20 to 70/ -29 to 21	11.5-12.6	15.5-14.4	14.3-15.6	.75-2.5
80/27	13.2-14.4	14.7-16.0	16.5-18.0	
90/32	14.3-15.5	16.4-17.8	17.7-19.3	
100/38	15.4-16.8	17.7-19.3	19.3-20.9	
110/43	11.5-12.6	15.5-14.4	14.3-15.6	

¹Times in minutes - Dice cube

24-HOUR ICE PRODUCTION

Air Temp. Entering Condenser °F/°C	Water Temperature °F/°C		
	50/10	70/21	90/32
-20 to 70/ -29 to 21	1715	1520	1410
90/32	1520	1375	1240
100/38	1415	1250	1160
110/43	1320	1160	1075

¹Ice slab weight of one harvest cycle = 15.5 lb. to 16.75 lb.

7.75 - 8.38 lb per evaporator

7.0 kg to 7.6 kg (3.5 to 3.8 kg per evaporator)

230/50/1 is approximately 12% lower than 230/60/1

OPERATING PRESSURES

Air Temp. Entering Condenser °F/°C	Freeze Cycle		Harvest Cycle	
	Discharge Pressure psig	Suction Pressure psig	Discharge Pressure psig	Suction Pressure psig
-20 to 50/ -29 to 10	215-250	50-30	140-155	65-90
70/21	215-260	50-33	140-155	65-90
80/27	240-280	50-34	145-165	65-95
90/32	250-295	55-35	150-170	65-95
100/38	290-365	65-36	160-190	75-100
110/43	300-380	70-37	170-200	80-110

I2170C/ICVD2095

Remote Air-Cooled Condensing Unit Model

Characteristics vary depending on operating conditions.

CYCLE TIMES

Freeze Time + Harvest Time = Total Cycle Time

Air Temp. Entering Condenser °F/°C	Freeze Time			Harvest Time
	Water Temperature °F/°C			
	50/10	70/21	90/32	
-20 to 70/ -29 to 21	10.7-11.6	11.7-12.8	12.5-13.7	.75-2.5
80/27	11.0-12.1	12.5-13.7	13.4-14.6	
90/32	12.1-13.2	12.9-14.0	14.4-15.7	
100/38	12.5-13.7	14.4-15.7	15.6-17.0	
110/43	13.4-14.6	15.6-17.0	16.9-18.4	

¹Times in minutes - Dice cube

24-HOUR ICE PRODUCTION

Air Temp. Entering Condenser °F/°C	Water Temperature °F/°C		
	50/10	70/21	90/32
-20 to 70/ -29 to 21	1835	1685	1590
80/27	1780	1590	1495
90/32	1640	1555	1400
100/38	1590	1400	1305
110/43	1495	1305	1210

¹Ice slab weight of one harvest cycle = 15.5 lb. to 16.75 lb.
7.75 - 8.38 lb per evaporator
7.0 kg to 7.6 kg (3.5 to 3.8 kg per evaporator)
230/50/1 is approximately 12% lower than 230/60/1

OPERATING PRESSURES

Air Temp. Entering Condenser °F/°C	Freeze Cycle		Harvest Cycle	
	Discharge Pressure psig	Suction Pressure psig	Discharge Pressure psig	Suction Pressure psig
-20 to 50/ -29 to 10	200-250	45-28	125-140	70-80
70/21	200-260	50-28	125-160	70-80
80/27	220-275	50-28	130-180	70-90
90/32	260-315	58-30	150-190	70-100
100/38	300-360	65-30	160-200	80-110
110/43	320-400	70-30	170-210	90-120

I2176C/ICVD2096

Remote Air-Cooled Condensing Unit Model

Characteristics vary depending on operating conditions.

CYCLE TIMES

Freeze Time + Harvest Time = Total Cycle Time

Air Temp. Entering Condenser °F/°C	Freeze Time			Harvest Time
	Water Temperature °F/°C			
	50/10	70/21	90/32	
-20 to 70/ -29 to 21	10.4-11.4	11.4-12.4	12.3-13.4	.75-2.5
80/27	11.3-12.3	12.1-13.2	13.2-14.4	
90/32	11.6-12.6	12.4-13.5	14.2-15.4	
100/38	12.8-13.9	13.9-15.1	15.3-16.6	
110/43	13.9-15.1	14.9-16.2	16.0-17.4	

¹Times in minutes - Dice cube

24-HOUR ICE PRODUCTION

Air Temp. Entering Condenser °F/°C	Water Temperature °F/°C		
	50/10	70/21	90/32
-20 to 70/ -29 to 21	1920	1785	1670
80/27	1800	1690	1565
90/32	1760	1655	1470
100/38	1610	1500	1375
110/43	1500	1405	1315

¹Ice slab weight of one harvest cycle = 15.5 lb. to 16.75 lb.
7.75 - 8.38 lb per evaporator
7.0 kg to 7.6 kg (3.5 to 3.8 kg per evaporator)
230/50/1 is approximately 12% lower than 230/60/1

OPERATING PRESSURES

Air Temp. Entering Condenser °F/°C	Freeze Cycle		Harvest Cycle	
	Discharge Pressure psig	Suction Pressure psig	Discharge Pressure psig	Suction Pressure psig
-20 to 50/ -29 to 10	220-250	45-28	125-140	70-80
70/21	220-260	50-28	125-160	70-80
80/27	220-275	50-28	130-180	70-90
90/32	260-315	58-30	150-190	70-100
100/38	300-360	65-30	160-200	80-110
110/43	320-400	70-30	170-210	90-120

Diagrams

Wiring Diagrams

The following pages contain electrical wiring diagrams. Be sure you are referring to the correct diagram for the ice machine you are servicing.

Warning

Always disconnect power before working on electrical circuitry.

Some components are wired differently on energy efficient machines. Please verify your model number (page 18) to reference the correct diagrams.

WIRING DIAGRAM LEGEND

The following symbols are used on all of the wiring diagrams:

- * Internal Compressor Overload
(Some models have external compressor overloads)
- ** Fan Motor Run Capacitor
(Some models do not incorporate fan motor run capacitor)
- () Wire Number Designation
(The number is marked at each end of the wire)
- >>— Multi-Pin Connection
(Electrical Box Side) —>>—
(Compressor Compartment Side)

ALL ICVD MODELS INTERCONNECTING WIRING

Verify Correct tap is used for transformer wires
230V = Orange & black - 208V = Red & Black

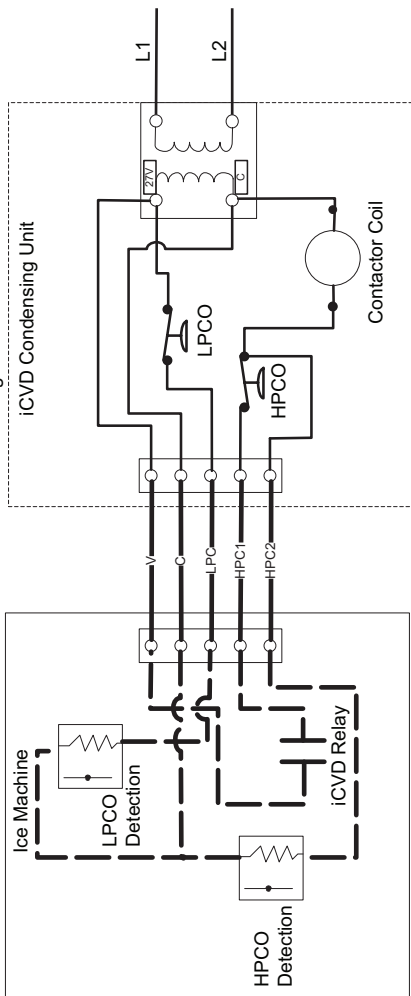

ICVD0695/ICVD0696/ICVD895/ICVD1095/ICVD1195 1PH

QuietQube® ICVD Condensing Unit

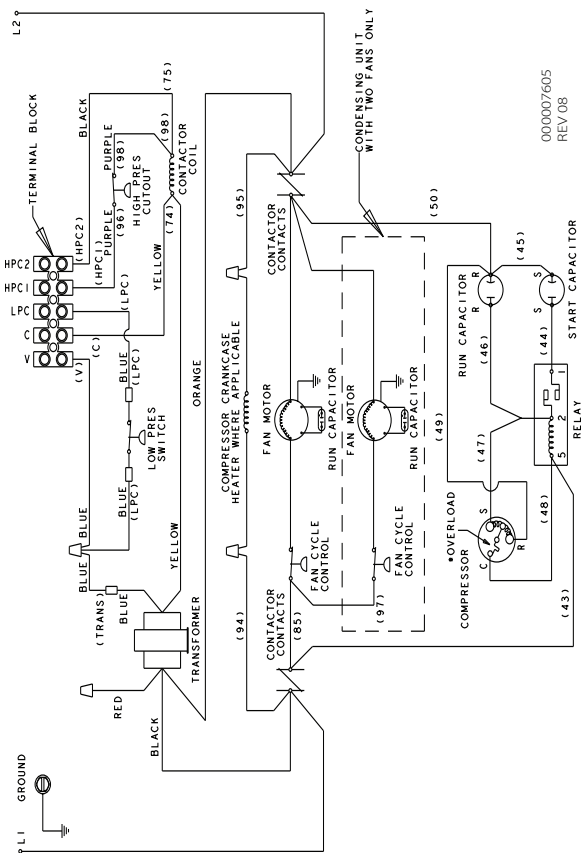

000007605
REV 08

ICVD0695/ICVD0696/ICVD895/ICVD1095/ICVD1195 3PH

QuietQube® ICVD Condensing Unit

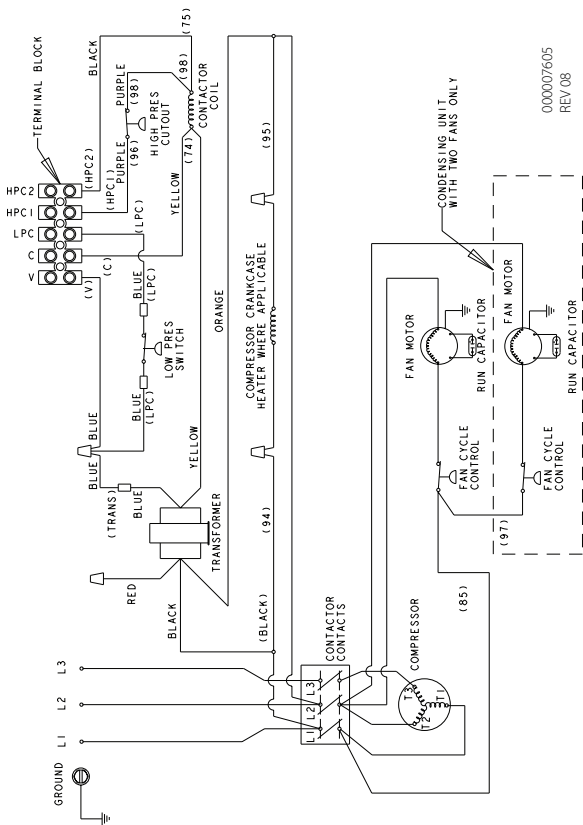

000007605
REV.08

IB0690C/IB0696C/IB0890C/IB1090C 1&3PH

QuietQube® Ice Machine Head Section

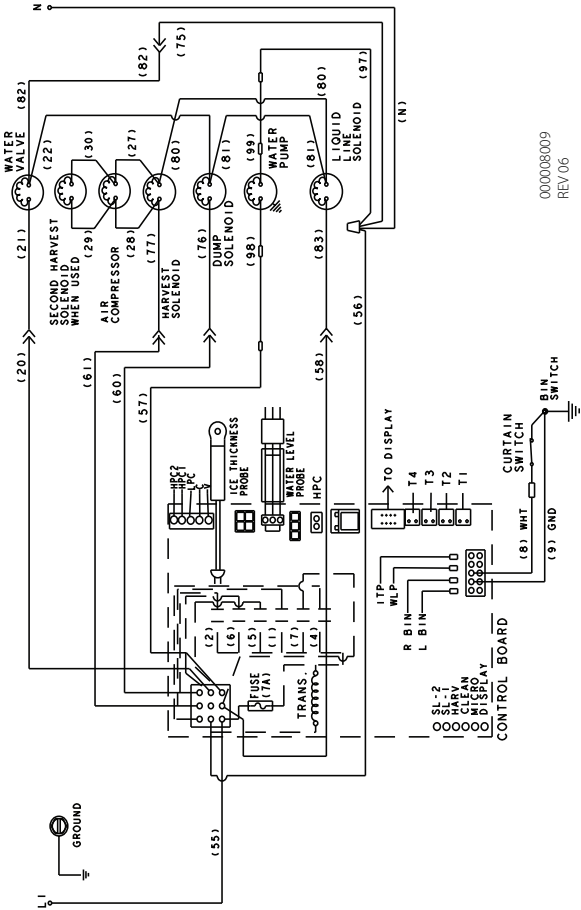

000008009
REV 06

ICVD0695/ICVD0696/ICD0895/ICVD0996/ICVD1195 1PH

QuietQube® ICVD Condensing Unit

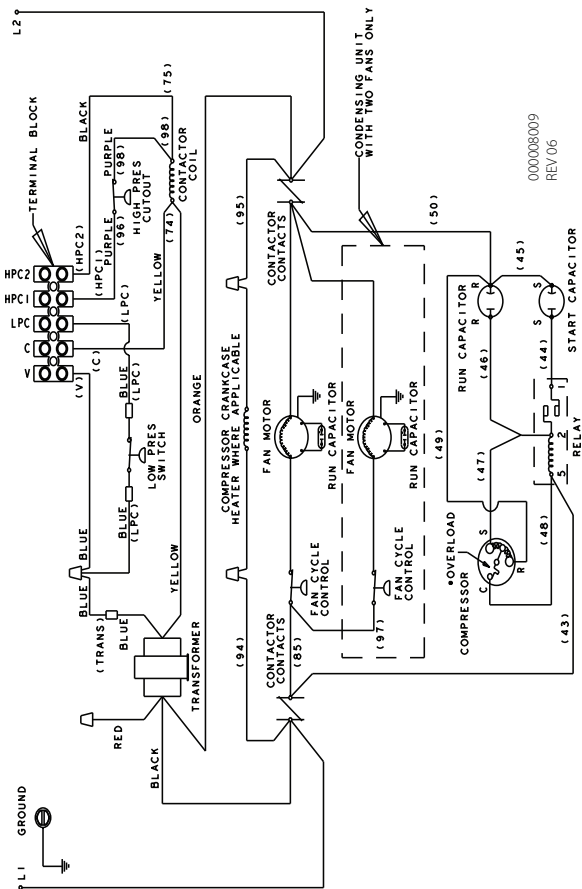

ICVD0695/ICVD0696/ICD0895/ICVD0996/ICVD1195 3PH

QuietQube® ICVD Condensing Unit

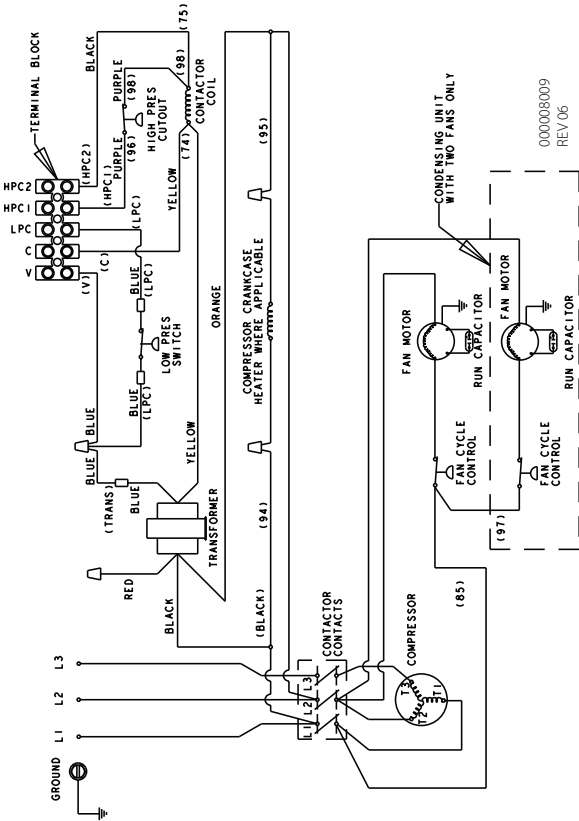

000008009
REV.06

I1470C/I1870C/I2170 1&3PH

QuietQube® Ice Machine Head Section

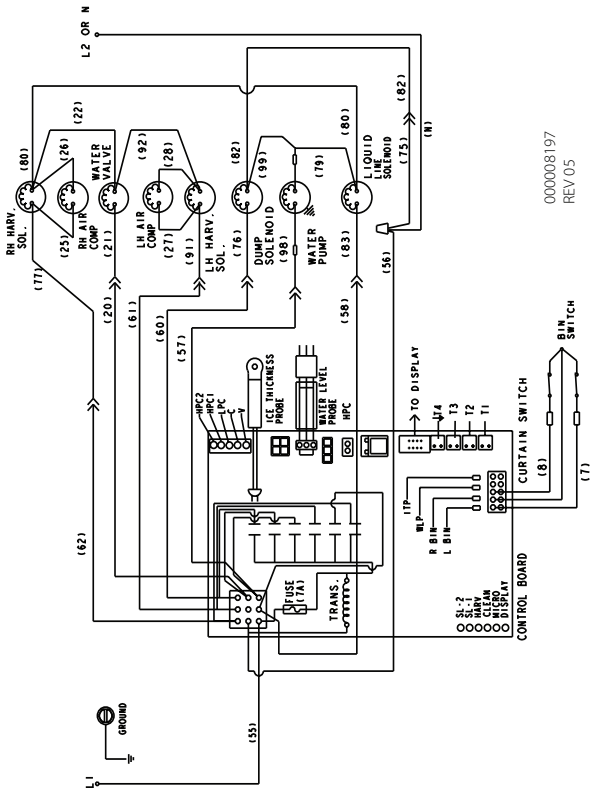

000008197
REV 05

ICVD1495/ICVD1496/ICVD1895 1PH

QuietQube® ICVD Condensing Unit

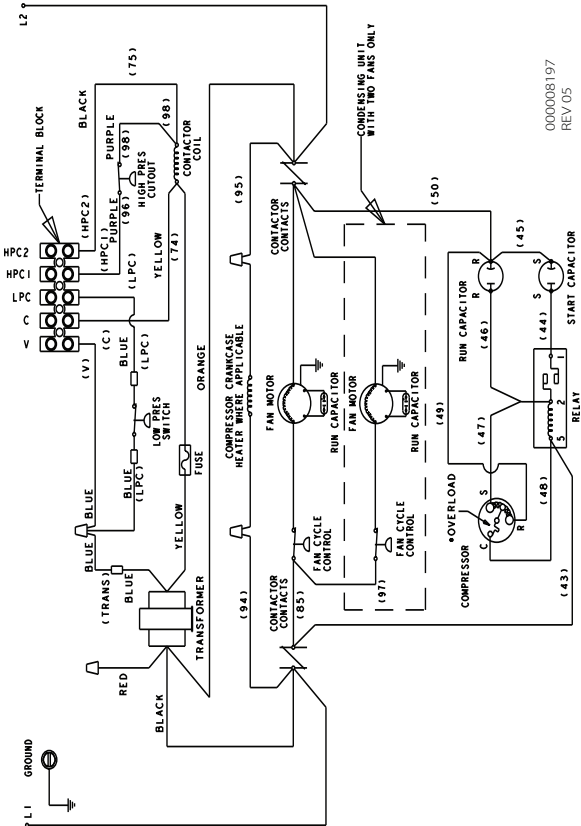

000008197
REV 05

ICVD2095 1PH

QuietQube® ICVD Condensing Unit

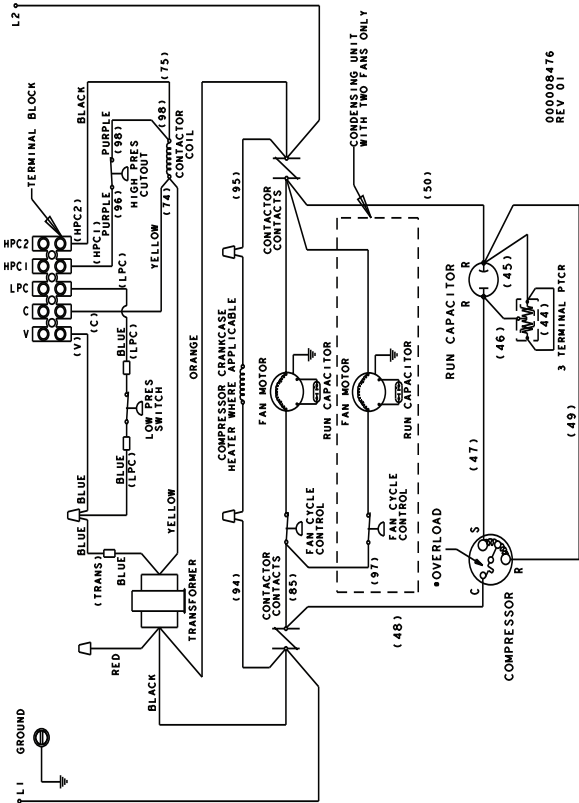

000008476
REV 01

ICVD2095 3PH

QuietQube® ICVD Condensing Unit

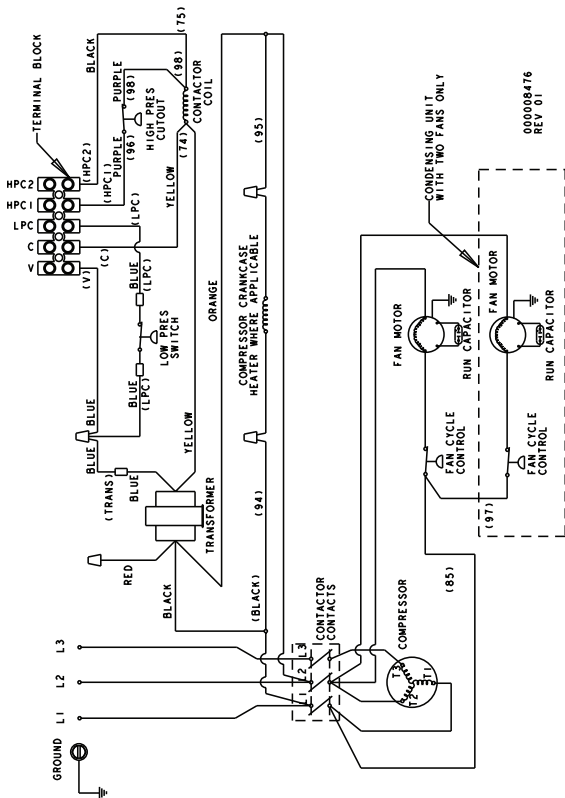

000008476
REV 01

I2176C 1&3PH

QuietQube® Ice Machine Head Section

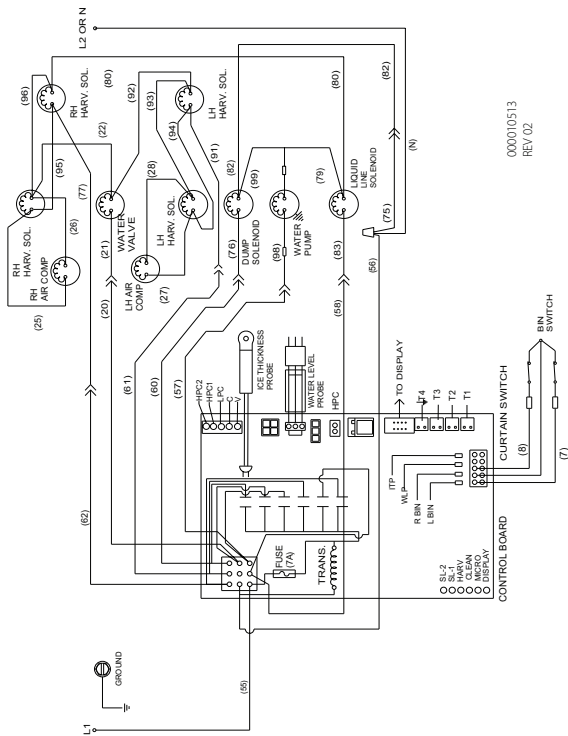

000010513
REV 02

ICVD2096 1PH

QuietQube® ICVD Condensing Unit

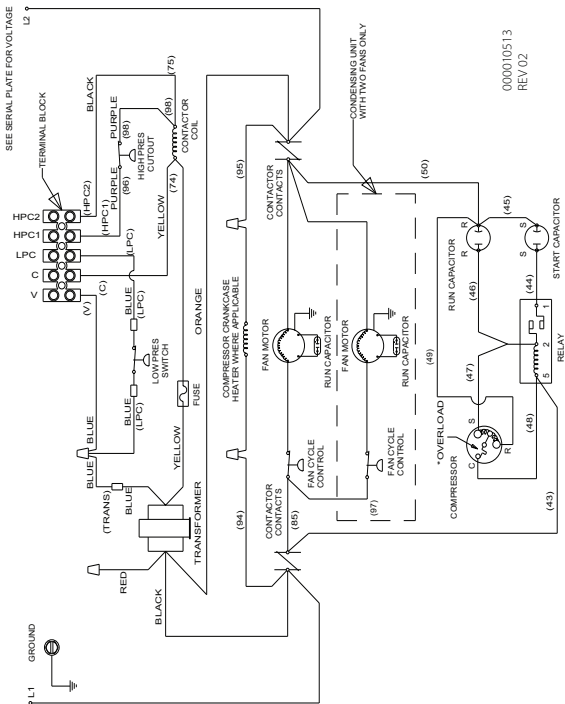

000010513
REV 02

Electronic Control Board

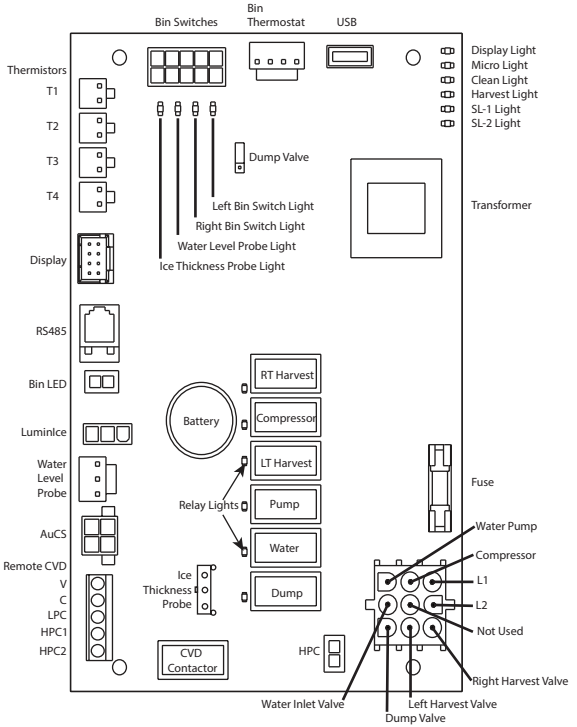

Refrigeration Tubing Schematics

REMOTE CONDENSING UNIT MODELS

I0680C/I0686C/I0870C/I0976C/I1070C/I1270C

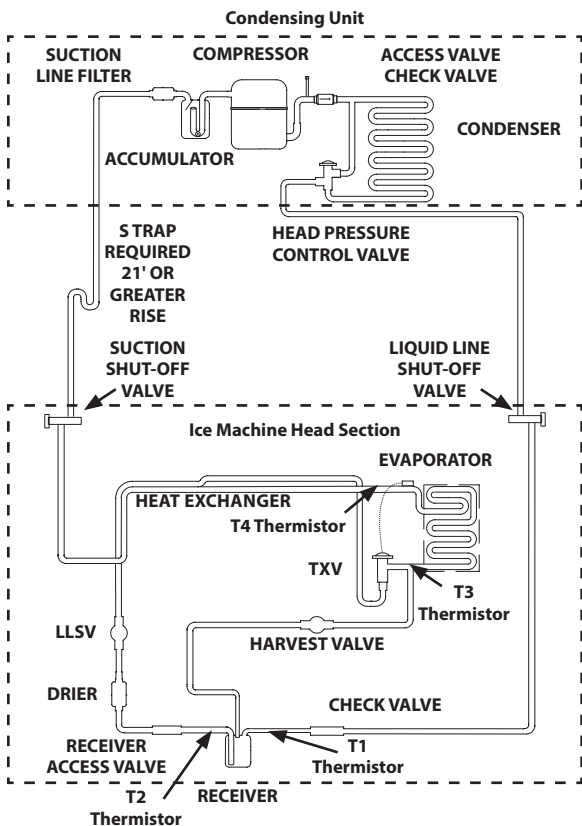

IB MODELS

IB0690C/IB0696C/IB0890C

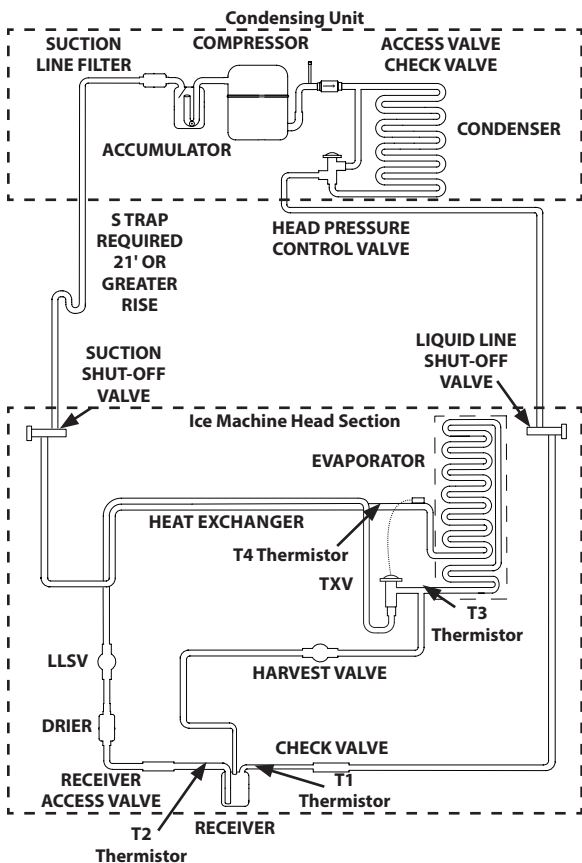

IB1090C/I1176C

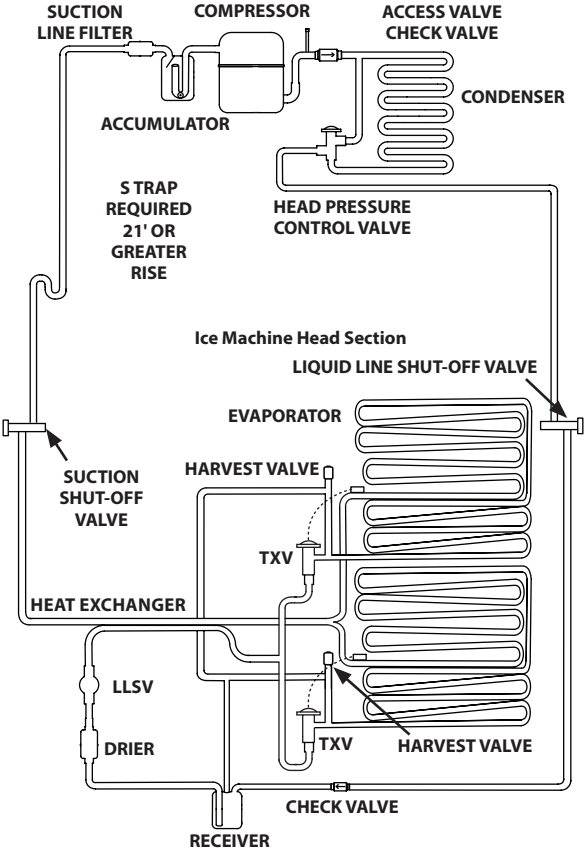

DUAL EVAPORATOR MODELS

I1470C/I1870C

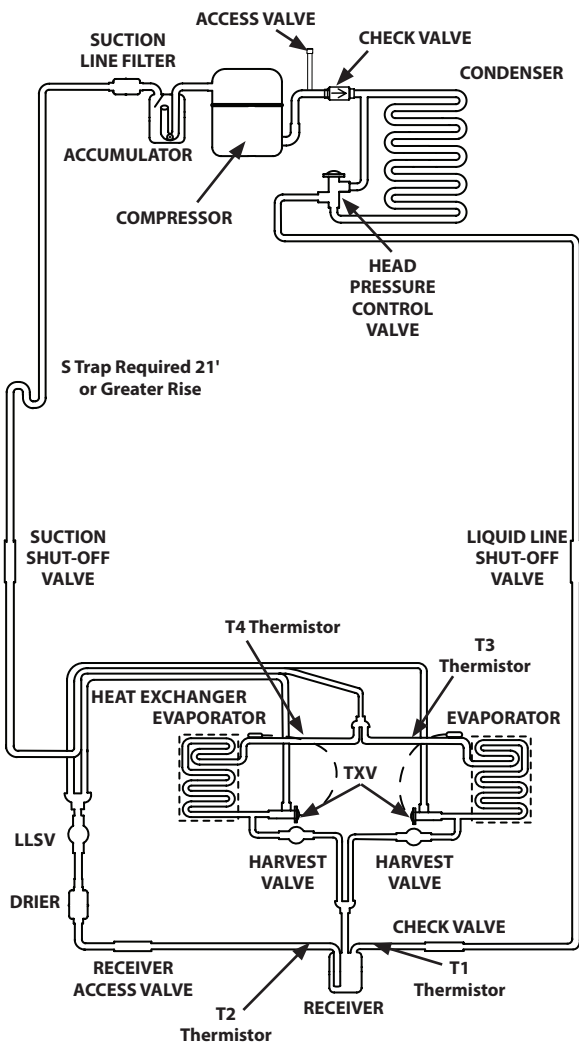

I2170C

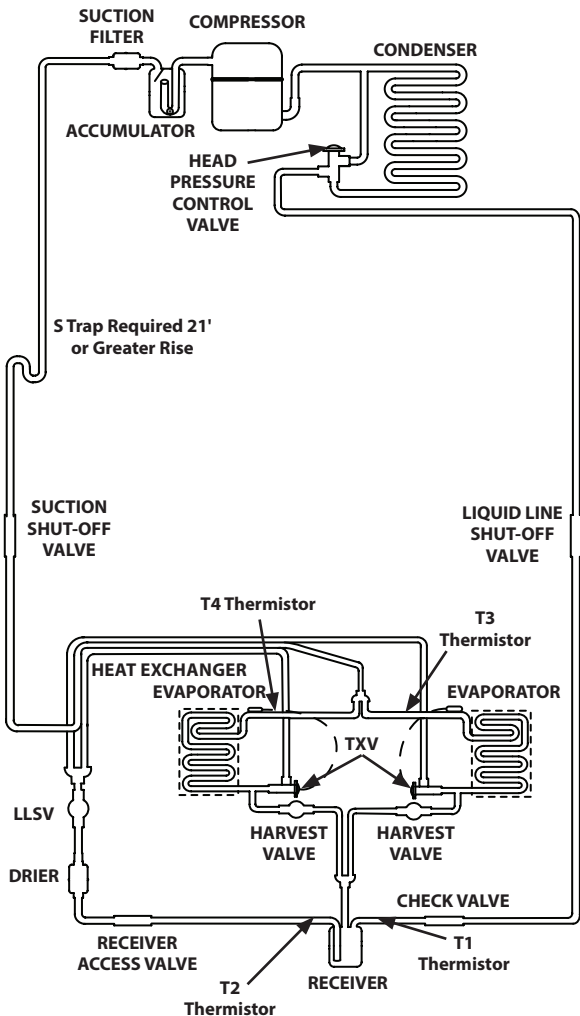

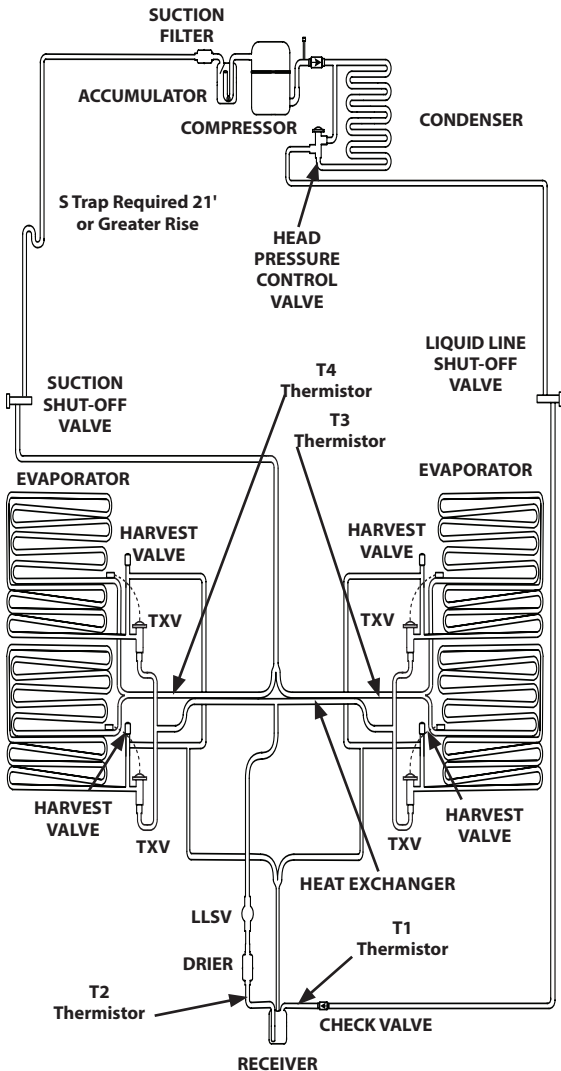

THIS PAGE INTENTIONALLY LEFT BLANK



MANITOWOC ICE
2110 SOUTH 26TH STREET
MANITOWOC, WI 54220

800-545-5720
WWW.MANITOWOCICE.COM

©2018 Manitowoc Ice except where explicitly stated. All rights reserved.

Continuing product improvement may necessitate change of specifications without notice.

Part Number 000014795 5/17