

# Manitowoc®

## Marine Q 1300 Ice Machine

### Installation and Owner/Operator Use and Care Manual

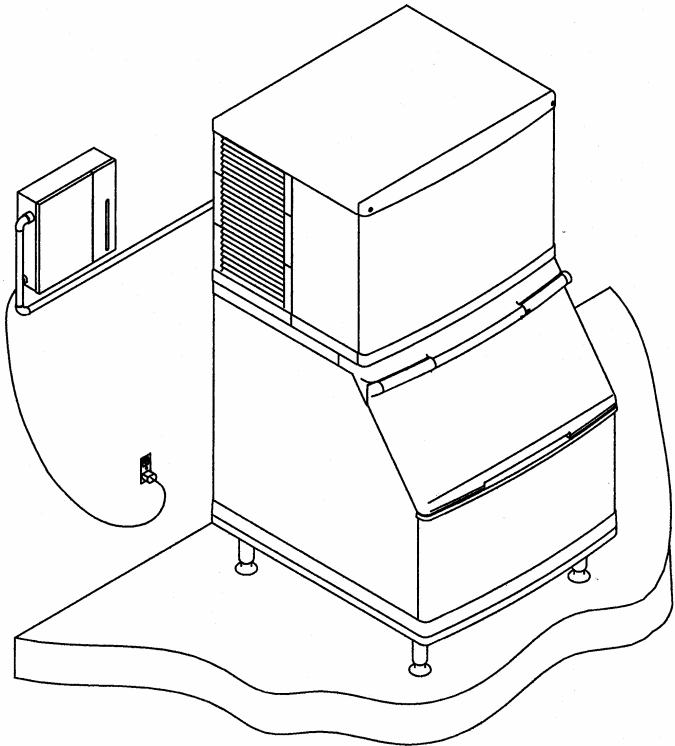

Thank you for selecting a Manitowoc Ice Machine, the dependability leader in ice making equipment and related products. With proper installation, care and maintenance, your new Manitowoc Ice Machine will provide you with many years of reliable and economical performance.

## Safety Notices

When using or servicing a Q Model Ice Machine, be sure to pay close attention to the safety notices in this manual. Disregarding the notices may lead to serious injury and/or damage to the ice machine.

Throughout this manual, you will see the following types of safety notices:

### **WARNING**

Text in a Warning box alerts you to a potential personal injury situation. Be sure to read the Warning statement, and then proceed carefully.

### **CAUTION**

Text in a Caution box alerts you to a situation in which you could damage the ice machine. Be sure to read the Caution statement, and then proceed carefully.

### **CAUTION**

Proper installation, care and maintenance are essential for maximum ice production and trouble-free operation of your Manitowoc Ice Machine.

Read and understand this manual. It contains valuable care and maintenance information. If you encounter problems not covered by this manual, feel free to contact Manitowoc Ice, Inc. We will be happy to provide assistance.

## Procedural Notices

When using or servicing a Q Model Ice Machine, be sure to read the procedural notices in this manual. These notices supply helpful and important information.

Throughout this manual, you will see the following types of procedural notices:

### **Important**

Important boxes serve two functions.

They call the operator's attention to important information.

They also provide the service technician with information that may help perform a procedure more efficiently. Disregarding this information may slow down the work.

NOTE: Text set off as a Note provides you with simple, but useful, extra information.

### **Important**

Routine adjustments and maintenance procedures outlined in this manual are not covered by the warranty.

## Table of Contents

<b>Model/Serial Number Location .....</b>	<b>1-2</b>
<b>Owner Warranty Registration Card.....</b>	<b>1-3</b>
<b>Warranty Coverage .....</b>	<b>1-3</b>
<b>General.....</b>	<b>2-1</b>
<b>Ice Machine Dimensions.....</b>	<b>2-1</b>
<b>Ice Storage Bin Dimensions .....</b>	<b>2-3</b>
<b>Location of Ice Machine .....</b>	<b>2-5</b>
<b>Leveling the Ice Storage Bin .....</b>	<b>2-6</b>
<b>Electrical Service.....</b>	<b>2-6</b>
<b>Water Service/Drains.....</b>	<b>2-10</b>
<b>Installation Checklist.....</b>	<b>2-19</b>
<b>Before Starting the Ice Machine.....</b>	<b>2-20</b>
<b>Component Identification .....</b>	<b>3-1</b>
<b>Ice Making Sequence of Operation .....</b>	<b>3-2</b>
<b>Operational Checks .....</b>	<b>3-4</b>
<b>General.....</b>	<b>4-1</b>
<b>Ice Machine Inspection.....</b>	<b>4-1</b>
<b>Exterior Cleaning.....</b>	<b>4-1</b>
<b>Cleaning the Condenser .....</b>	<b>4-1</b>
<b>Interior Cleaning and Sanitizing .....</b>	<b>4-3</b>
<b>Removal of Parts for Cleaning/Sanitizing .....</b>	<b>4-6</b>
<b>Water Treatment/Filtration.....</b>	<b>4-11</b>
<b>Checklist.....</b>	<b>5-1</b>
<b>Safety Limit Feature.....</b>	<b>5-2</b>

# Table of Contents

---

*Page Intentionally Left Blank*

## Section 1 General Information

### Owner Warranty Registration Card

#### GENERAL

Warranty coverage begins the day your new ice machine is installed.

#### Important

Complete and mail the OWNER WARRANTY REGISTRATION CARD as soon as possible to validate the installation date.

If you do not return your OWNER WARRANTY REGISTRATION CARD, Manitowoc will use the date of sale to the Manitowoc Distributor as the first day of warranty coverage for your new ice machine.

### Warranty Coverage

#### GENERAL

The following Warranty outline is provided for your convenience. For a detailed explanation, read the warranty bond shipped with each product.

Contact your local Manitowoc representative or Manitowoc Ice, Inc. if you need further warranty information.

#### Important

This product is intended exclusively for commercial application. No warranty is extended for personal, family, or household purposes.

#### PARTS

1. Manitowoc warrants the ice machine against defects in materials and workmanship, under normal use and service for three (3) years from the date of original installation.
2. The evaporator and compressor are covered by an additional two (2) year (five years total) warranty beginning on the date of the original installation.

#### LABOR

1. Labor required to repair or replace defective components is covered for three (3) years from the date of original installation.
2. The evaporator is covered by an additional two (2) year (five years total) labor warranty beginning on the date of the original installation..

#### EXCLUSIONS

The following items are not included in the ice machine's warranty coverage:

1. Normal maintenance, adjustments and cleaning as outlined in this manual.
2. Repairs due to unauthorized modifications to the ice machine or use of non-standard parts without prior written approval from Manitowoc Ice, Inc.
3. Damage caused by improper installation of the ice machine, electrical supply, water supply or drainage, or damage caused by floods, storms, or other acts of God.
4. Premium labor rates due to holidays, overtime, etc.; travel time; flat rate service call charges; mileage and miscellaneous tools and material charges not listed on the payment schedule. Additional labor charges resulting from the inaccessibility of equipment are also excluded.
5. Parts or assemblies subjected to misuse, abuse, neglect or accidents.
6. Damage or problems caused by installation, cleaning and/or maintenance procedures inconsistent with the technical instructions provided in this manual.
7. This product is intended exclusively for commercial application. No warranty is extended for personal, family, or household purposes.

#### AUTHORIZED WARRANTY SERVICE

To comply with the provisions of the warranty, a refrigeration service company, qualified and authorized by your Manitowoc distributor, or a Contracted Service Representative must perform the warranty repair.

Normal maintenance, adjustments and cleaning as outlined in this manual are not covered by the warranty.

*Page Intentionally Left Blank*

## Section 2 Installation Instructions

### General

These instructions are provided to assist the qualified installer. Check your local Yellow Pages for the name of the nearest Manitowoc distributor, or call Manitowoc Ice, Inc. for information regarding start-up services.

**Important**  
Failure to follow these installation guidelines may affect warranty coverage.

### Ice Machine Dimensions

#### Q1300 ICE MACHINE

WATER COOLED

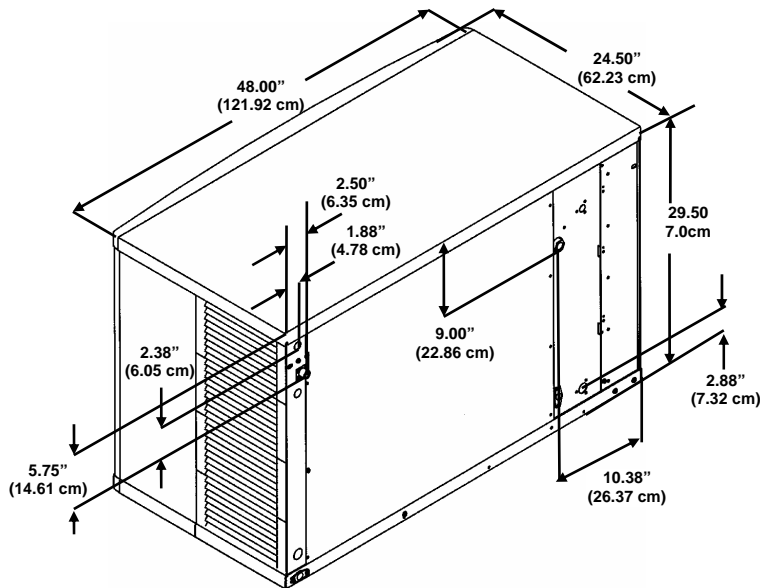

## Location of Ice Machine

The location selected for the ice machine must meet the following criteria. If any of these criteria are not met, select another location.

- The location must be free of airborne and other contaminants.
- The air temperature must be at least 35°F (1.6°C), but must not exceed 110°F (43.4°C).
- The location must not be near heat-generating equipment or in direct sunlight.
- The location must not obstruct air flow through or around the ice machine. Refer to the chart below for clearance requirements.

	Water-Cooled
Top/Sides	24" (609 mm)*
Back	24" (609 mm)*

\*There is no minimum clearance required. This value is recommended for efficient operation and servicing only.

## Leveling the Ice Storage Bin

1. Screw the leveling legs onto the bottom of the bin.
2. Screw the foot of each leg in as far as possible.

**CAUTION**

The legs must be screwed in tightly to prevent them from bending.

3. Move the bin into its final position.
4. Level the bin to assure that the bin door closes and seals properly. Use a level on top of the bin. Turn each foot as necessary to level the bin.
5. Inspect bin gasket prior to ice machine installation. (Manitowoc bins come with a closed cell foam gasket installed along the top surface of the bin.)
6. Install ice machine on bin.

NOTE: An optional caster assembly is available for use in place of the legs. Installation instructions are supplied with the casters.

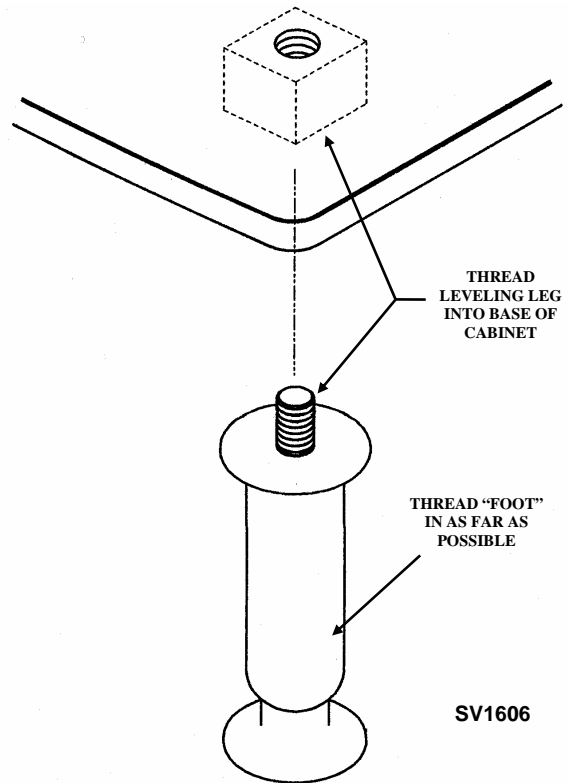

**Leveling Leg and Foot**

## Electrical Service

### GENERAL

**⚠ WARNING**

All wiring must conform to local, state and national codes.

### VOLTAGE

The maximum allowable voltage variation is  $\pm 10\%$  of the rated voltage at ice machine start-up (when the electrical load is highest).

**⚠ WARNING**

The ice machine must be grounded in accordance with national and local electrical codes.

### FUSE/CIRCUIT BREAKER

A separate fuse/circuit breaker must be provided for each ice machine. Circuit breakers must be H.A.C.R. rated (does not apply in Canada).

### MINIMUM CIRCUIT AMPACITY

The minimum circuit ampacity is used to help select the wire size of the electrical supply. (Minimum circuit ampacity is not the ice machine's running amp load.)

The wire size (or gauge) is also dependent upon location, materials used, length of run, etc., so it must be determined by a qualified electrician.

## Q1000 ICE MACHINE

Ice Machine	Voltage Phase Cycle	Water Cooled	
		Maximum Fuse Circuit Breaker	Minimum Circuit Amps
Q1300	208-230/1/60	30	18.1
	208-230/3/60	20	11.6
	230/1/50	30	14.3

## Electrical Wiring Connections

**⚠ WARNING**

These diagrams are not intended to show proper wire routing, wire sizing, disconnects, etc., only the correct wire connections.

All electrical work, including wire routing and grounding, must conform to local, state and national electrical codes.

Though wire nuts are shown in the drawings, the ice machine field wiring connections may use either wire nuts or screw terminals.

### Water Cooled Ice Machine

#### 208-230/1/60

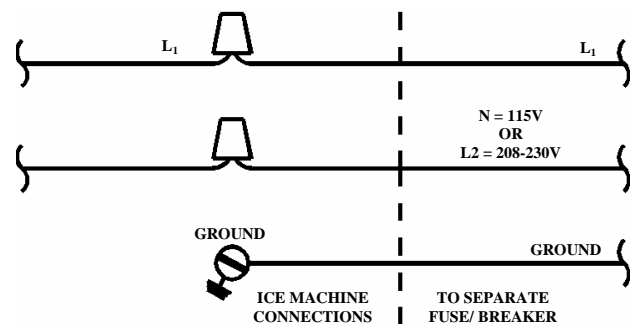

SV1258

## Water Service/Drains

### Water Inlet Lines

Follow these guidelines to install water inlet lines:

- Do not connect the ice machine to a hot water supply. Be sure all hot water restrictors installed for other equipment are working. (Check valves on sink faucets, dishwashers, etc.)
- If water pressure exceeds the maximum recommended pressure, obtain a water pressure regulator from your Manitowoc distributor.
- Install a water shut-off valve for both the ice making and condenser water lines.
- Insulate water inlet lines to prevent condensation.
- Use teflon tape to seal threaded fittings.

 **CAUTION**  
Do not apply heat to water valve inlet fitting. This will damage plastic valve body.

**Important**  
Install sump trough drain plug before starting the ice machine.

## Drain Connections

Follow these guidelines when installing drain lines to prevent drain water from flowing back into the ice machine and storage bin:

- Drain lines must have a 1.5 inch drop per 5 feet of run (2.5 cm per meter), and must not create traps.
- The floor drain must be large enough to accommodate drainage from all drains.
- Run separate bin and ice machine drain lines. Insulate them to prevent condensation.
- Vent the bin and ice machine drain to the atmosphere. Do not vent the condenser drain on water-cooled models.

 **CAUTION**  
Plumbing must conform to applicable codes.

### WATER SUPPLY AND DRAIN LINE SIZING/CONNECTIONS

Location	Water Temperature	Water Pressure	Ice Machine Fitting	Tubing Size Up to Ice Machine Fitting
Ice Making Water Inlet	33°F (0.6°C) Min. 90°F (32.2°C) Max.	20 psi (137.9 kPa) Min. 80 psi (551.5 kPa) Max.	3/8" Female Pipe Thread	3/8" (9.5 mm) minimum inside diameter
Ice Making Water Drain	---	---	1/2" Female Pipe Thread	1/2" (12.7 mm) minimum inside diameter
Condenser Water Inlet	33°F (0.6°C) Min. 90°F (32.2°C) Max.	20 psi (137.9 kPa) Min. 150 psi (1034.2 kPa) Max.	1/2" Female Pipe Thread	
Condenser Water Drain	---	---	1/2" Female Pipe Thread	1/2" (12.7 mm) minimum inside diameter
Bin Drain	---	---	3/4" Female Pipe Thread	3/4" (19.1 mm) minimum inside diameter

WATER SUPPLY AND DRAIN LINE SIZING ILLUSTRATION

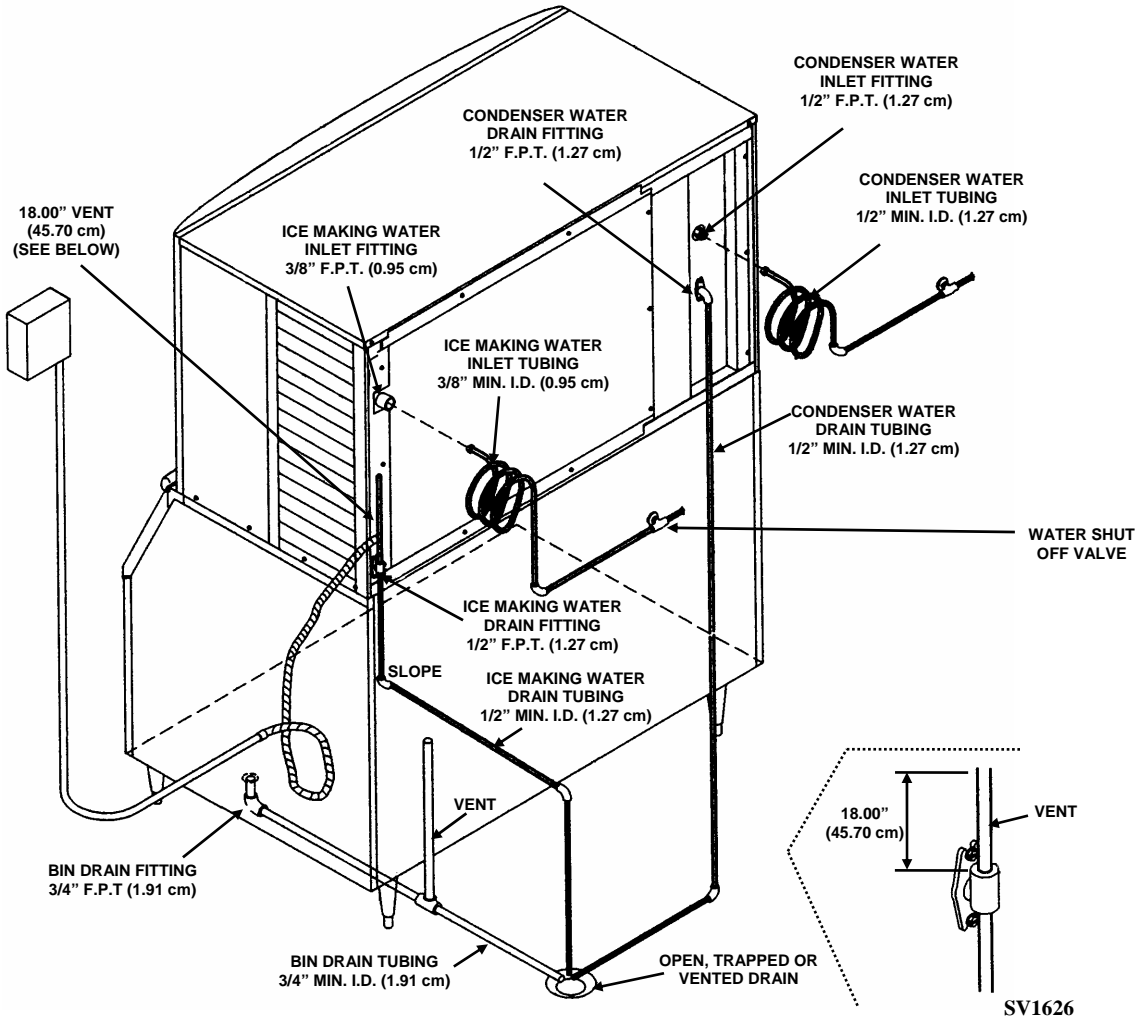

Typical Water Supply Drain Installation

## Installation Checklist

- Is the ice machine level?
- Has all of the internal packing been removed?
- Have all of the electrical and water connections been made?
- Has the sump trough drain plug been installed?
- Has the supply voltage been tested and checked against the rating on the nameplate?
- Is their proper clearance around the ice machine for air circulation?
- Has the ice machine been installed where ambient temperatures will remain in the range of 35° - 110°F (1.7° - 43.3°C)?
- Has the ice machine been installed where the incoming water temperature will remain in the range of 33° - 90°F (0.6° - 32.2°C)?
- Is there a separate drain for the water-cooled condenser?
- Are the ice machine and bin drains vented?
- Are all electrical leads free from contact with refrigeration lines and moving equipment?
- Has the owner/operator been instructed regarding maintenance and the use of Manitowoc Cleaner and Sanitizer?
- Has the owner/operator completed the warranty registration card?
- Has the ice machine and bin been sanitized?

## Before Starting the Ice Machine

All Manitowoc ice machines are factory-operated and adjusted before shipment. Normally, new installations do not require any adjustment.

To ensure proper operation, follow the Operational Checks in this manual. Starting the ice machine and completing the Operational Checks are the responsibilities of the owner/operator.

Adjustments and maintenance procedures outlined in this manual are not covered by the warranty.



### **WARNING**

#### **PERSONNEL INJURY POTENTIAL**

Do not operate equipment that has been misused, abused, neglected, damaged, or altered/modified from that of original manufactured specifications.

Section 3  
Ice Machine Operation

Component Identification

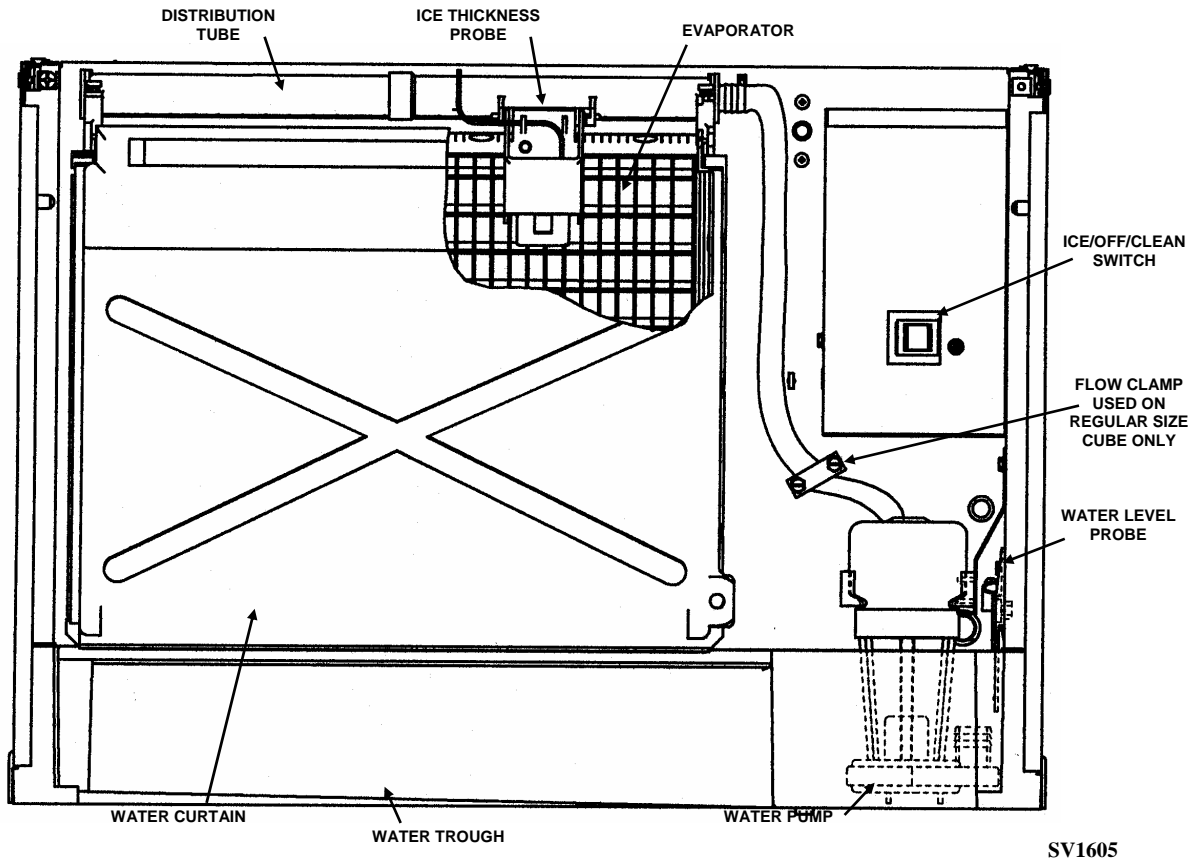
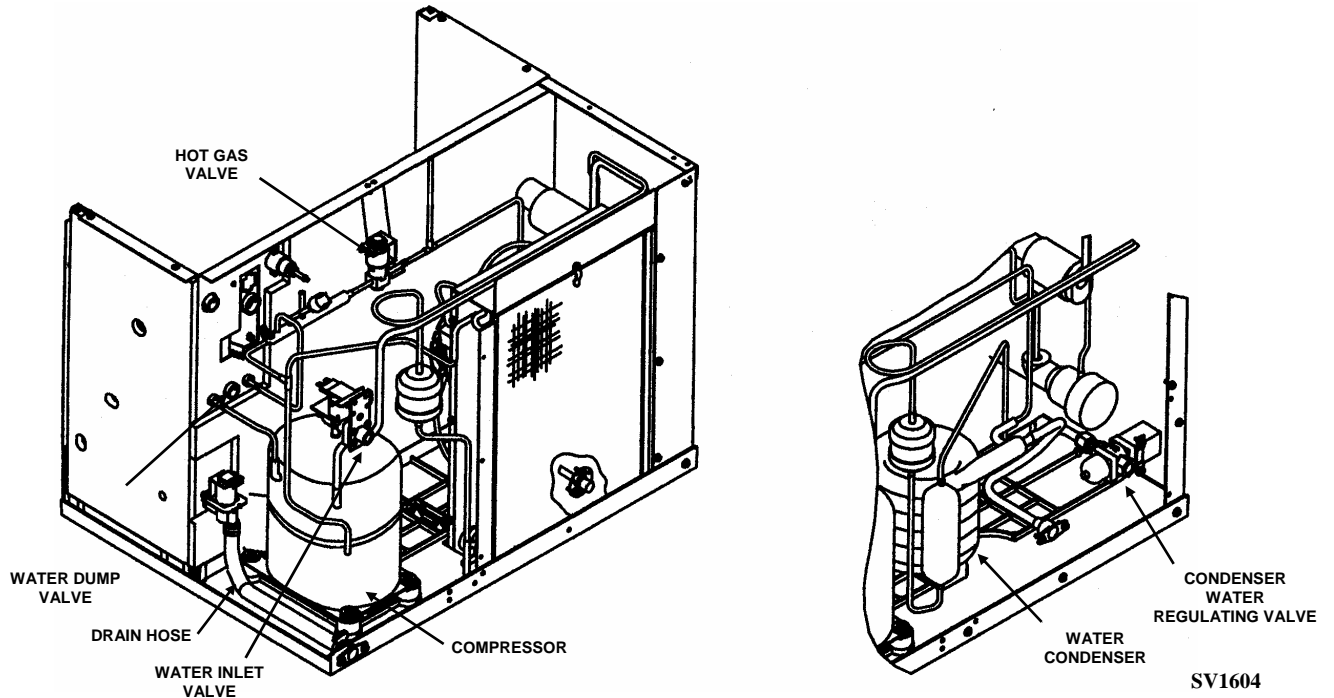

## Ice Making Sequence of Operation

### Initial Start-Up or Start-Up After Automatic Shut-Off

#### 1. Water Purge

Before the compressor starts, the water pump and water dump solenoid are energized for 45 seconds to purge the ice machine of old water. This ensures that the ice-making cycle starts with fresh water.

The hot gas valve is also energized during the water purge, although it stays on for an additional 5 seconds (50 second total on time) during the initial refrigeration system start-up.

#### 2. Refrigeration System Start-Up

The compressor starts after the 45-second water purge, and remains on throughout the entire Freeze and Harvest Sequences. The hot gas valve remains on for 5 seconds during initial compressor start-up and then shuts off.

The water fill valve is energized at the same time as the compressor.

At the same time the compressor starts, the condenser fan motor (air-cooled models) is supplied with power throughout the entire Freeze and Harvest Sequences. The fan motor is wired through a fan cycle pressure control, therefore it may cycle on and off. (The compressor and condenser fan motor are wired through the contactor. As a result, any time the contactor coil is energized, the compressor and fan motor are supplied with power.)

### FREEZE SEQUENCE

#### 3. Prechill

The compressor is on for 30 seconds prior to water flow to prechill the evaporator. The water fill valve remains on until the water level probe is satisfied.

#### 4. Freeze

The water pump restarts after the 30-second prechill. An even flow of water is directed across the evaporator and into each cube cell, where it freezes. The water fill valve will cycle on, then off one more time to refill the water trough.

When sufficient ice has formed, the water flow (not the ice) contacts the ice thickness probe. After approximately 7 seconds of continual water contact, the harvest sequence is initiated. The ice machine cannot initiate a harvest sequence until a 6-minute freeze lock has been surpassed.

### HARVEST SEQUENCE

#### 5. Water Purge

The water pump continues to run, and the water dump valve energizes for 45 seconds to purge the water in the sump trough. The water fill valve energizes for the last 15 seconds of the 45-second water purge.

After the 45 second water purge, the water fill valve, water pump and dump valve de-energize. (Refer to "Water Purge Adjustment" on page 3-5 for details.)

The hot gas valve also opens at the beginning of the water purge to divert hot refrigerant gas into the evaporator.

#### 6. Harvest

The hot gas valve remains open and the refrigerant gas warms the evaporator causing the cubes to slide, as a sheet, off the evaporator and into the storage bin. The sliding sheet of cubes swings the water curtain out, opening the bin switch.

The momentary opening and re-closing of the bin switch terminates the harvest sequence and returns the ice machine to the Freeze Sequence (steps 3 - 4).

### AUTOMATIC SHUT-OFF

#### 7. Automatic Shut-Off

When the storage bin is full at the end of a harvest sequence, the sheet of cubes fails to clear the water curtain and will hold it open. After the water curtain is held open for 7 seconds, the ice machine shuts off. The ice machine remains off for 3 minutes before it can automatically restart.

The ice machine remains off until enough ice has been removed from the storage bin to allow the ice to fall clear of the water curtain. As the water curtain swings back to the operating position, the bin switch re-closes and the ice machine restarts (steps 1 - 2), provided the 3-minute delay period is complete.

## Section 3

## Ice Machine Operation

### Operational Checks

#### GENERAL

Your Manitowoc ice machine was factory-operated and adjusted before shipment. Normally, a newly installed ice machine does not require any adjustment.

To ensure proper operation, always follow these Operational Checks when starting the ice machine:

- for the first time
- after a prolonged out of service period
- after cleaning and sanitizing

Routine adjustments and maintenance procedures outlined in this manual are not covered by the warranty.

#### WATER LEVEL

The water level sensor is set to maintain the proper water level above the water pump housing. The water level is not adjustable.

If the water level is incorrect, check the water level probe for damage (probe bent, etc.). Repair or replace the probe as necessary.

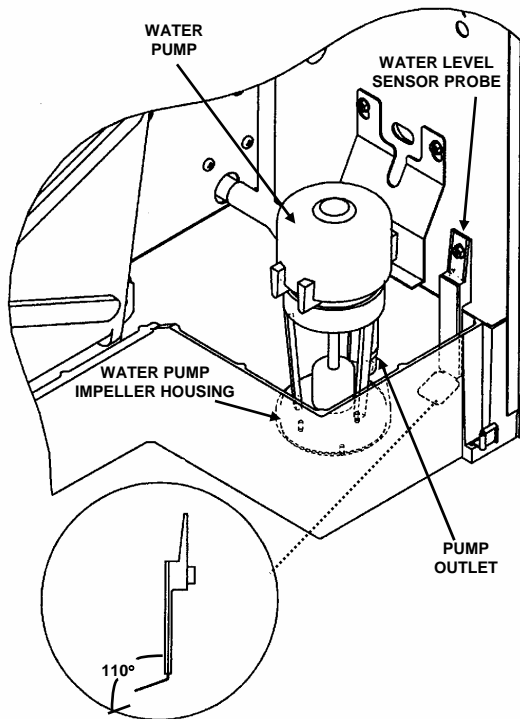

SV1616

#### ICE THICKNESS CHECK

After a harvest cycle, inspect the ice cubes in the ice storage bin. The ice thickness probe is factory-set to maintain an ice bridge of 1/8 inch (3.2mm). If an adjustment is needed, follow the steps below.

1. Turn the ice thickness probe adjustment screw clockwise for a thicker ice bridge, or counterclockwise for a thinner ice bridge.

#### IMPORTANT

It is normal for cubes to have a slight dimple. This is a normal characteristic associated with Manitowoc's unique shape.

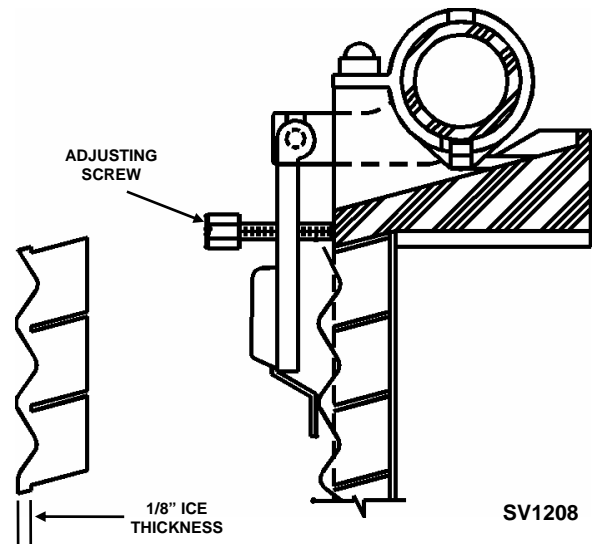

#### Ice Thickness Adjustment

2. Make sure the ice thickness probe wire and bracket do not restrict movement of the probe.

## HARVEST SEQUENCE WATER PURGE

The harvest sequence water purge adjustment may be used when the ice machine is hooked up to special water systems, such as a de-ionized water treatment system.

### Important

The harvest sequence water purge is factory-set at 45 seconds. A shorter purge setting is not recommended. This can increase water system cleaning and sanitizing requirements.

- The harvest sequence water purge may be set to 15, 30, or 45 seconds.
- During the harvest sequence water purge, the water fill valve energizes and de-energizes by time. The water purge must be at the factory setting of 45 seconds for the water fill valve to energize during the last 15 seconds of the water purge. If it is set to less than 45 seconds, the water fill valve will not energize during the water purge.

### WARNING

Disconnect the electrical power to the ice machine at the electrical disconnect before proceeding.

For your safety, and to eliminate errors, we recommend that a qualified service technician make the harvest water purge adjustment.

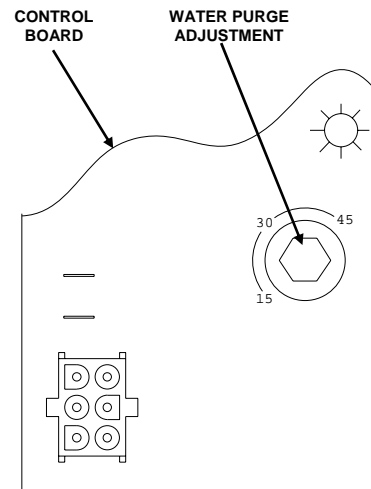

SV1617

## Water Purge Adjustment

## **Section 4 Maintenance**

### **WATER-COOLED CONDENSER AND WATER REGULATING VALVE**

The water-cooled condenser and water-regulating valve may require cleaning due to scale build-up.

Low ice production, high water consumption and high operating temperatures and pressures all may be symptoms of restrictions in the condenser water circuit.

Because the cleaning procedures require special pumps and cleaning solutions, they must be performed by qualified maintenance or service personnel. Follow the manufacturer instructions for the specific product used.

### **MANITOWOC'S PATENTED CLEANING OR SANITIZING TECHNOLOGY**

Manitowoc ice machines include technology that allows the initiation and completion of a cleaning or sanitizing cycle at the flip of a switch. This cycle will permit cleaning or sanitizing of all surfaces that come in contact with the water distribution system.

Periodic maintenance must be performed that includes sanitizing the bin (or dispenser) and adjacent surface areas, which can not be contacted by the water distribution system.

This technology will also allow initiation and completion of a clean or sanitize cycle after which the ice machine automatically starts ice making again.

Refer to the cleaning or sanitizing procedure for complete details.

Interior Cleaning and Sanitizing

GENERAL

Clean and sanitize the ice machine every six months for efficient operation. If the ice machine requires more frequent cleaning and sanitizing, consult a qualified service company to test the water quality and recommend appropriate water treatment or installation of the AuCS® accessory (Automatic Cleaning System). If required, an extremely dirty ice machine may be taken apart for cleaning and sanitizing.

 **CAUTION**

Use only Manitowoc approved Ice Machine Cleaner (part number 94-0546-3) and Sanitizer (part number 94-0565-3). It is a violation of Federal law to use these solutions in a manner inconsistent with their labeling. Read and understand all labels printed on bottles before use.

 **CAUTION**

Do not mix Ice Machine Cleaner and Sanitizer solutions together. It is a violation of Federal law to use these solutions in a manner inconsistent with their labeling.

 **WARNING**

Wear rubber gloves and safety goggles (and/or face shield) when handling Ice Machine Cleaner or Sanitizer.

**CLEANING PROCEDURE**

Ice machine cleaner is used to remove lime scale or other mineral deposits. It is not used to remove algae or slime. Refer to “Sanitizing Procedure” on the next page for removal of algae and slime. To initiate a cleaning cycle using Manitowoc’s Patented Cleaning Technology use the following procedure.

**Step 1** Set the toggle switch to the OFF position after ice falls from the evaporator at the end of a Harvest cycle. Or, set the switch to the OFF position and allow the ice to melt off the evaporator.

 **CAUTION**

Never use anything to force ice from the evaporator. Damage may result.

**Step 2** To start a cleaning cycle, move the toggle switch to the CLEAN position. The water will flow through the water dump valve and down the drain. The Clean light will turn on to indicate the ice machine is in the Clean mode.

**Step 3** Wait about one minute or until water starts to flow over the evaporator.

**Step 4** Add the proper amount of Manitowoc Ice Machine Cleaner to the water trough.

Model	Amount of Cleaner
Q1300	9 ounces (270 ml)

**Step 5** The ice machine will automatically time out a ten-minute cleaning cycle, followed by six rinse cycles, and then stop. The Clean light will turn off to indicate the clean mode is completed. This entire cycle lasts approximately 25 minutes.

**NOTE:** Periodic cleaning must be performed on adjacent surface areas not contacted by the water distribution system.

**Step 6** When the cleaning process stops, move the toggle switch to the OFF position. Refer to “Sanitizing Procedure” on the next page.

**Step 7**

- A. The ice machine may be set to start and finish a cleaning procedure, and then automatically start ice making again.
- B. Wait about one minute into the cleaning cycle (until water starts to flow over the evaporator), then move the switch from CLEAN to ICE position.
- C. When the cleaning cycle is completed, the clean light will turn off and a ice making sequence will start automatically.

**NOTE:** After the toggle switch is moved to the ICE position, opening the curtain switch will interrupt the cleaning sequence. The sequence will resume from the point of interruption when the curtain switch closes.

## Sanitizing Procedure

Use sanitizer to remove algae or slime. Do not use it to remove lime scale or other mineral deposits. To initiate a sanitizing cycle using Manitowoc's Patented Cleaning/Sanitizing Technology use the following procedure.

**Step 1** Set the toggle switch to the OFF position after ice falls from the evaporator at the end of a Harvest cycle. Or, set the switch to the OFF position and allow the ice to melt off the evaporator.



### CAUTION

Never use anything to force ice from the evaporator. Damage may result.

**Step 2** To start a sanitizing cycle, move the toggle switch to the CLEAN position. The water will flow through the water dump valve and down the drain. The Clean light will turn on to indicate the ice machine is in the Cleaning mode.

**Step 3** Wait about one minute or until water starts to flow over the evaporator.

**Step 4** Add the proper amount of Manitowoc Ice Machine Sanitizer to the water trough.

Model	Amount of Sanitizer
Q1300	6 ounces (180 ml)

**Step 5** The ice machine will automatically time out a ten-minute sanitizing cycle, followed by six rinse cycles, and then stop. The Clean light will turn off to indicate the sanitizing mode is completed. This entire cycle lasts approximately 25 minutes.

**Note:** Periodic cleaning must be performed on adjacent surface areas not contacted by the water distribution system. If the bin requires sanitizing, remove all of the ice and sanitize it with a solution of 1 ounce (30 ml) of sanitizer with up to 4 gallons (15/l) of water.

**Step 6** When the sanitizing process stops, move the toggle switch to the ICE position to start making ice again.

### Step 7

- A. The ice machine may be set to start and finish a sanitizing procedure, and then automatically start ice making again.
- B. Wait about one minute into the sanitizing cycle (until water starts to flow over the evaporator), then move the switch from WASH to ICE position.
- C. When the sanitizing cycle is completed, the clean light will turn off and a ice making sequence will start automatically.

**NOTE:** After the toggle switch is moved to the ICE position, opening the curtain switch will interrupt the sanitizing sequence. The sequence will resume from the point of interruption when the curtain switch closes.

## REMOVAL OF PARTS FOR CLEANING OR SANITIZING

1. Turn off the water supply to the ice machine at the water service valve.



### WARNING

Disconnect electric power to the ice machine at the electric switch box before proceeding.

2. Remove the parts of the water curtain and the components you want to clean or sanitize. See the following pages for removal procedures for these parts.



### WARNING

Wear rubber gloves and safety goggles (and/or face shield) when handling Ice Machine Cleaner or Sanitizer.

1. Soak the removed part(s) in a properly mixed solution.

Solution Type	Water	Mixed With
Cleaner	1 gal. (4 l)	16 oz (500 ml) cleaner
Sanitizer	4 gal. (15 l)	1 oz (30 ml) sanitizer

4. Use a soft-bristle brush or sponge (NOT a wire brush) to carefully clean the parts.



### CAUTION

Do not mix Cleaner and Sanitizer solutions together. It is a violation of Federal law to use these solutions in a manner inconsistent with their labeling.



### CAUTION

Do not immerse the water pump motor in the cleaning or sanitizing solution.

5. Use the solution and a brush to clean the top, sides, and bottom evaporator extrusions; the inside of the ice machine panels; and the entire inside of the bin.
6. Thoroughly rinse all of the parts and surfaces with clean water.
7. Install the removed parts.

**NOTE:** Incomplete rinsing of the ice thickness probe or water level probe may leave a residue. This could cause the ice machine to malfunction. For best results, brush or wipe the probes off while rinsing it. Thoroughly dry the probes before installing them.

8. Turn on the water and electrical supply.

**Water Dump Valve**

The water dump valve normally does not require removal for cleaning. To determine if removal is necessary:

1. Locate the water dump valve.
2. Set the toggle switch to ICE.
3. While the ice machine is in the freeze mode, check the dump valve's clear plastic outlet drain hose for leakage.
  - A. If the dump valve is leaking, remove, disassemble and clean it.
  - B. If the dump valve is not leaking, do not remove it. Instead, follow the "Cleaning Procedure" on page 4-3.

Follow the procedure below to remove the dump valve.

**⚠ WARNING**

Disconnect the electric power to the ice machine at the electric service switch box and turn off the water supply before proceeding.

1. If so equipped, remove the water dump valve shield from its mounting bracket.
2. Lift and slide the coil retainer cap from the top of the coil.
3. Note the position of the coil assembly on the valve for assembly later. Leaving the wires attached, lift the coil assembly off the valve body and the enclosing tube.
4. Press down on the plastic nut on the enclosing tube and rotate it 1/4 turn. Remove the enclosing tube, plunger, and plastic gasket from the valve body.

NOTE: At this point, the water dump valve can easily be cleaned. If complete removal is desired, continue with step 5.

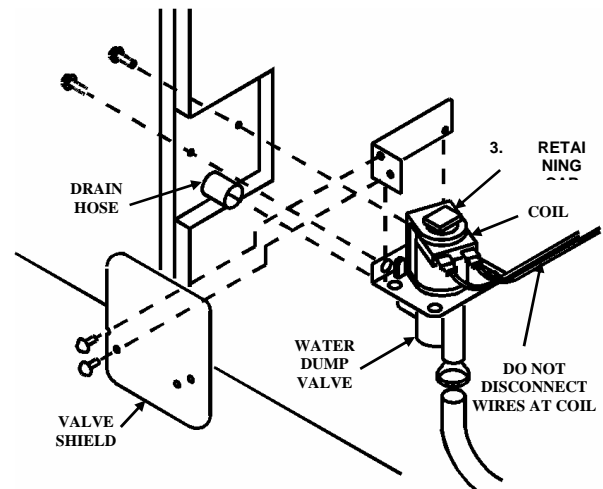
**Dump Valve Removal****Important**

The plunger and the inside of the enclosing tube must be completely dry before assembly.

NOTE: During cleaning, do not stretch, damage or remove the spring from the plunger. If it is removed, slide the spring's flared end into the plunger's slotted top opening until the spring contacts the plunger spring stop.

5. Remove the valve body.
6. Remove the tubing from the dump valve by twisting the clamps off.
7. Remove the two screws securing the dump valve and the mounting bracket.

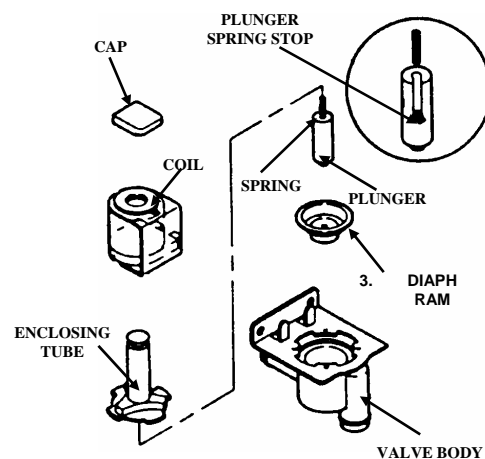
**Dump Valve Disassembly**

## Water Pump

**⚠ WARNING**

Disconnect the electric power to the ice machine at the electric service switch box and turn off the water supply.

1. Disconnect the water pump power cord.

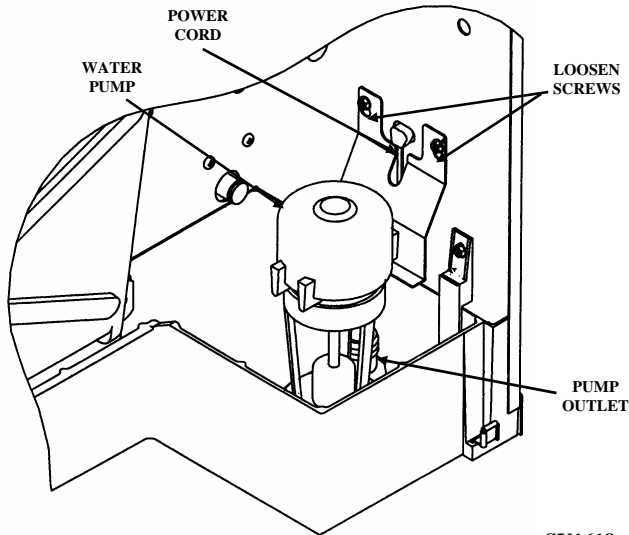

SV1618

### Water Pump Removal

2. Disconnect the hose from the pump outlet.
3. Loosen the screws securing the pump mounting bracket to the bulkhead.
4. Lift the pump and bracket assembly off the screws.

## Ice Thickness Probe

1. Compress the side of the ice thickness probe near the top hinge pin and remove it from the bracket.

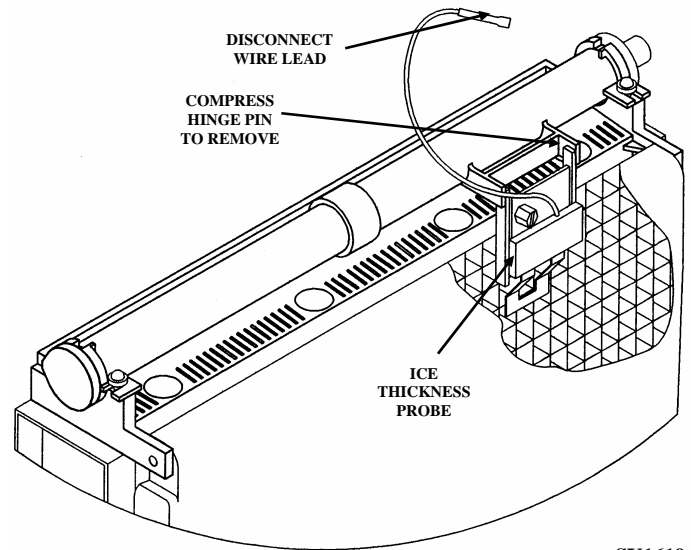

SV1619

### Ice Thickness Probe Removal

NOTE: At this point, the ice thickness probe can easily be cleaned. If complete removal is desired, continue with step 2 below.

**⚠ WARNING**

Disconnect the electric power to the ice machine at the electric service switch box.

2. Disconnect the wire lead from the control board inside the electrical control box.

## Water Level Probe

1. Loosen the screw that holds the water level probe in place. The probe can easily be cleaned at this point without proceeding to step 2.

**! WARNING**  
 Disconnect the electrical power to the ice machine at the electrical disconnect before proceeding.

2. If complete removal is required, disconnect the wire lead from the control board inside the electrical control box.

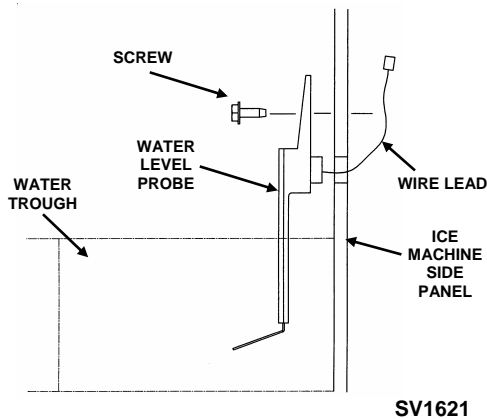

**Water Level Probe Removal**

## Water Inlet Valve

The water inlet valve normally does not require removal for cleaning. Follow the instructions below to determine if removal is necessary.

1. Set the ICE/OFF/CLEAN switch to OFF. Locate the water inlet valve (in the water area of the ice machine). It pours water into the water trough.
2. When the ice machine is off, the water inlet valve must completely stop water flow into the machine. Watch for water flow. If water flows, remove, disassemble and clean the valve.
3. When the ice machine is on, the water inlet valve must allow the proper water flow through it. Set the toggle switch to ON. Watch for water flow into the ice machine. If the water flow is slow or only trickles into the ice machine, remove disassemble, and clean the valve.

Follow the procedure below to remove the water inlet valve.

**! WARNING**  
 Disconnect the electric power to the ice machine at the electric service switch box and turn off the water supply before proceeding.

1. Remove the valve shield if necessary.
2. Remove the filter access screws that hold the valve in place.

NOTE: The water inlet valve can be disassembled and cleaned without disconnecting the incoming water supply line to the ice machine.

3. Remove, clean, and install the filter screen.
4. If necessary, remove the enclosure tube access screws to clean interior components.

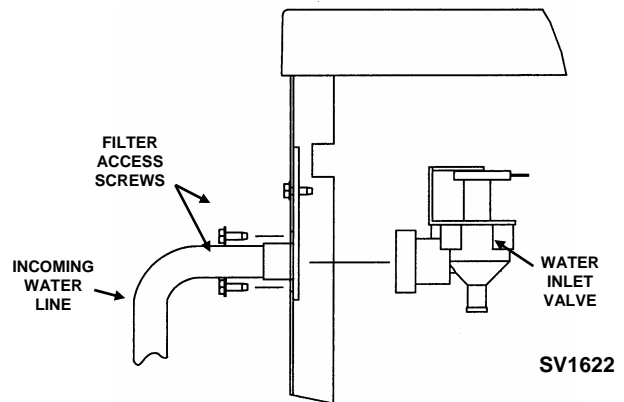

**Water Inlet Valve Removal**

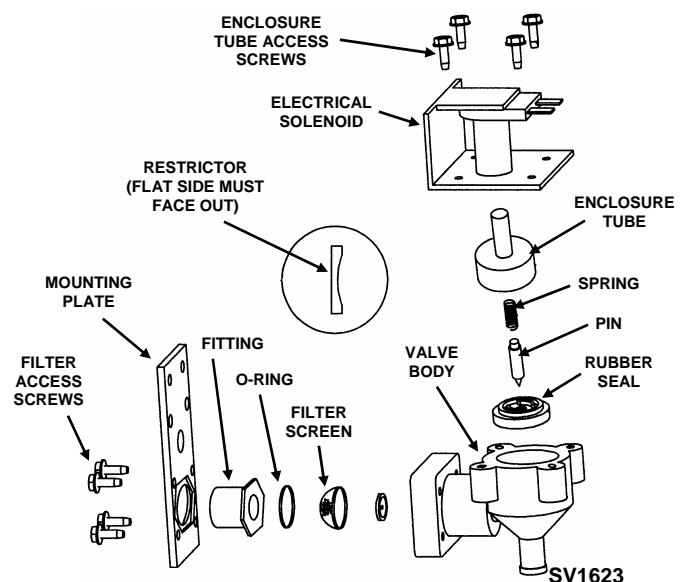

**Exploded View of Water Inlet Valve**

## Water Distribution Tube

1. Disconnect the water hose from the distribution tube.

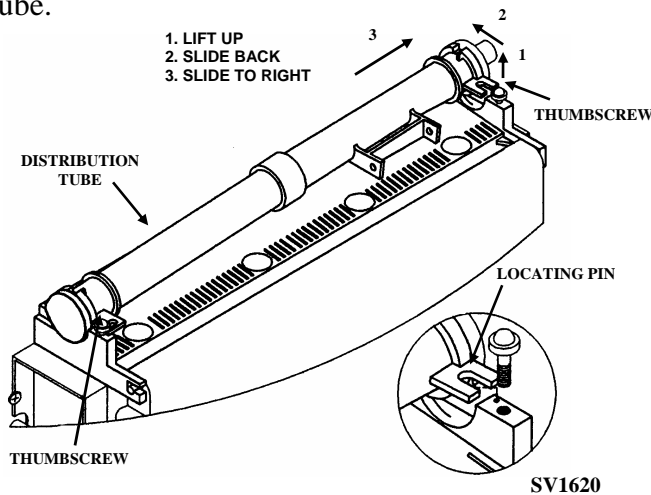

### Water Distribution Tube Removal

1. Loosen the two thumbscrews, which secure the distribution tube.
2. Lift the right side of the distribution tube up off the locating pin, then slide it back and to the right.

### ! CAUTION

Do not force this removal. Be sure the locating pin is clear of the hole before sliding the distribution tube out.

3. Disassemble for cleaning.
  - A. Twist both of the inner tube ends until the tabs line up with the keyways.
  - B. Pull the inner tube ends outward.

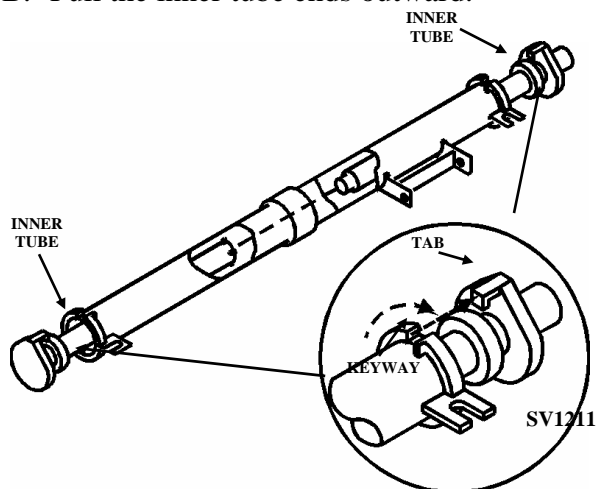

### Water Distribution Tube Disassembly

## Water Curtain

1. Gently flex the curtain in the center and remove it from the right side.

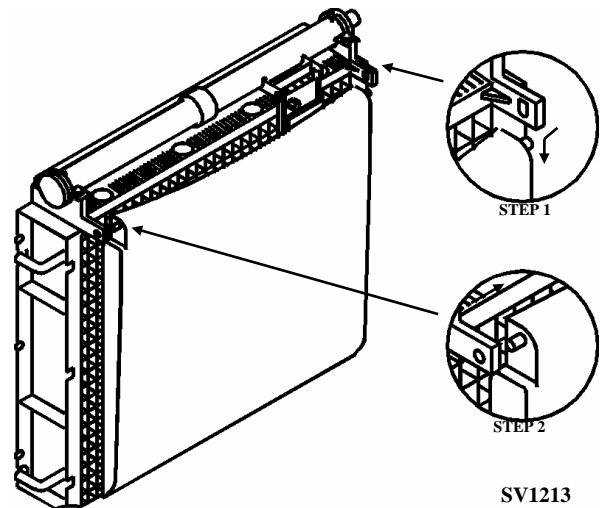

### Water Curtain Removal

2. Slide the left pin out.

## Section 5 Before Calling for Service

### Checklist

If a problem arises during operation of your ice machine, follow the checklist below before calling for service. Routine adjustments and maintenance procedures are not covered by the warranty.

Problem	Possible Cause	To Correct
Ice machine does not operate.	No electrical power to the ice machine.	Replace the fuse/reset the breaker/turn on the main switch.
	ICE/OFF/CLEAN toggle switch set improperly.	Move the toggle switch to the ICE position.
	Water curtain stuck open.	Water curtain must be installed and swinging freely.
Ice machine stops, and can be restarted by moving the toggles switch to OFF and back to ICE.	Safety limit feature stopping the ice machine.	Refer to "Safety Limit Feature" on the next page.
Ice machine does not release ice or is slow to harvest.	Ice machine is dirty.	Clean and sanitize the ice machine.
	Ice machine is not level.	Level the ice machine.
	Water regulating valve leaks in harvest mode (water-cooled models).	Adjust or Replace Water-regulating valve.
Ice machine does not cycle into harvest mode.	The six-minute freeze time lock-in has not expired yet.	Wait for freeze lock-in to expire.
	Ice thickness probe is dirty.	Clean and sanitize the ice machine.
	Ice thickness probe wire is disconnected.	Connect the wire.
	Ice thickness probe is out of adjustment.	Adjust the ice thickness probe.
	Uneven ice fill (thin at top of evaporator).	See "Shallow or Incomplete Cubes" on the next page.
Ice quality is poor (soft or not clear).	Poor incoming water quality.	Contact a qualified service company to test the quality of the incoming water and make appropriate filter recommendations.
	Water filtration is poor.	Replace the filter.
	Ice machine is dirty.	Clean and sanitize the ice machine.
	Water dump valve is not working.	Disassemble and clean the water dump valve.

*Continued on next page...*

Problem	Possible Cause	To Correct
Ice machine produces shallow or incomplete cubes, or the ice fill pattern on the evaporator is incomplete.	Ice thickness probe is out of adjustment.	Adjust the ice thickness probe.
	Water trough level is too high or too low.	Check the water level probe for damage.
	Water inlet valve filter screen is dirty.	Remove the water inlet valve and clean the filter screen.
	Water filtration is poor.	Replace the filter.
	Hot incoming water.	Connect the ice machine to a cold water supply
	Water inlet valve is not working.	Remove the water inlet valve and clean it.
	Incorrect incoming water pressure.	Water pressure must be 20-80 psi (137.9 - 551.5 kPA).
Low ice capacity.	Ice machine is not level.	Level the ice machine.
	Water inlet valve filter screen is dirty.	Remove the water inlet valve and clean the filter screen.
	Incoming water supply is shut off.	Open the water service valve.
	Water inlet valve stuck open or leaking.	Remove the water inlet valve and clean it.

**Safety Limit Feature**

In addition to the standard safety controls, such as the high pressure cutout, your Manitowoc ice machine features built-in safety limits which will stop the ice machine if conditions arise which could cause a major component failure.

Before calling for service, re-start the ice machine using the following procedure:

1. Move the ICE/OFF/CLEAN switch to OFF and then back to ICE.
  - A. If the safety limit feature has stopped the ice machine, it will restart after a short delay. Proceed to step 2.
  - B. If the ice machine does not restart, see “Ice machine does not operate” on the previous page.
2. Allow the ice machine to run to determine if the condition is recurring.
  - A. If the ice machine stops again, the condition has recurred. Call for service.
  - B. If the ice machine continues to run, the condition has corrected itself. Allow the ice machine to continue running.



We reserve the right to make product improvements at any time.

Specifications and design are subject to change without notice.

**MANITOWOC ICE, INC.**

2110 South 26th Street P.O. Box 1720

Manitowoc, WI 54221-1720

Phone: (920) 682-0161

Fax: (920) 683-7585

**Web Site** - [www.manitowocice.com](http://www.manitowocice.com)

©2000 Manitowoc Ice, Inc.

Litho in U.S.A.