

Manitowoc®

Marine Q 1300 Ice Machine

Service Manual

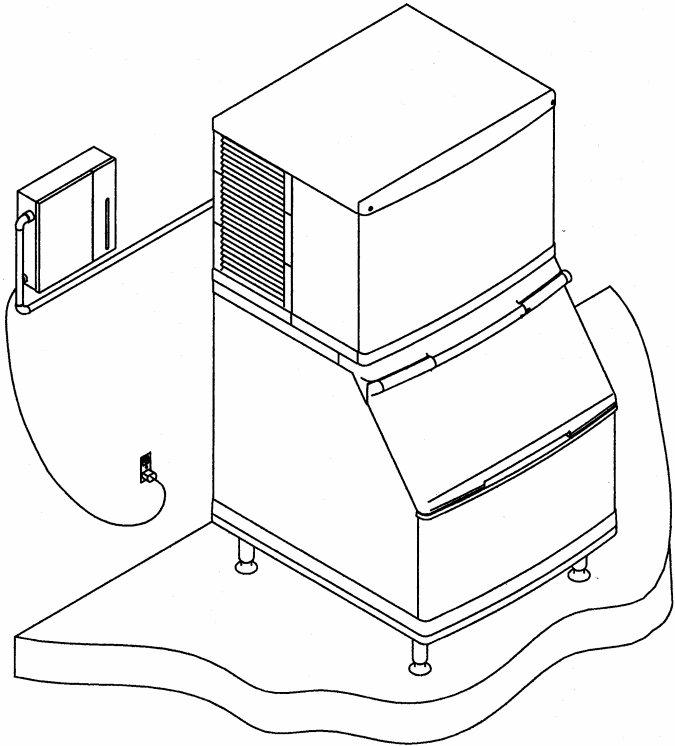

Thank you for selecting a Manitowoc Ice Machine, the dependability leader in ice making equipment and related products. With proper installation, care and maintenance, your new Manitowoc Ice Machine will provide you with many years of reliable and economical performance.

Safety Notices

When using or servicing a Q Model Ice Machine, be sure to pay close attention to the safety notices in this manual. Disregarding the notices may lead to serious injury and/or damage to the ice machine.

Throughout this manual, you will see the following types of safety notices:

WARNING

Text in a Warning box alerts you to a potential personal injury situation. Be sure to read the Warning statement, and then proceed carefully.

CAUTION

Text in a Caution box alerts you to a situation in which you could damage the ice machine. Be sure to read the Caution statement, and then proceed carefully.

CAUTION

Proper installation, care and maintenance are essential for maximum ice production and trouble-free operation of your Manitowoc Ice Machine.

Read and understand this manual. It contains valuable care and maintenance information. If you encounter problems not covered by this manual, feel free to contact Manitowoc Ice, Inc. We will be happy to provide assistance.

Procedural Notices

When using or servicing a Q Model Ice Machine, be sure to read the procedural notices in this manual. These notices supply helpful and important information.

Throughout this manual, you will see the following types of procedural notices:

Important

Important boxes serve two functions.

They call the operator's attention to important information.

They also provide the service technician with information that may help perform a procedure more efficiently. Disregarding this information may slow down the work.

NOTE: Text set off as a Note provides you with simple, but useful, extra information.

Important

Routine adjustments and maintenance procedures outlined in this manual are not covered by the warranty.

Table of Contents

Electrical System

Energized Parts Charts

Self-Contained Water-Cooled Models	1
--	---

Wiring Diagram Sequence of Operation

Self-Contained Models.....	2
----------------------------	---

Wiring Diagrams

Wiring Diagram Legend.....	9
----------------------------	---

Self-Contained - Q1300 - 1 Phase	10
--	----

Component Specifications and Diagnostics

Main Fuse	11
-----------------	----

Bin Switch	11
------------------	----

Compressor Electrical Diagnostics.....	13
--	----

PTCR Diagnostics	14
------------------------	----

Ice/Off/Clean Toggle Switch	17
-----------------------------------	----

Control Board Relays	17
----------------------------	----

Electronic Control Board	18
--------------------------------	----

Ice Thickness Probe (Harvest Initiation)

How the Probe Works	20
---------------------------	----

Harvest/Safety Limit Light	20
----------------------------------	----

Freeze Time Lock-In Feature	20
-----------------------------------	----

Maximum Freeze Time.....	20
--------------------------	----

Diagnosing Ice Thickness Control Circuitry

Ice Machine Does Not Cycle Into Harvest When Water Contacts The Ice Thickness Probe.....	21
--	----

Ice Machine Cycles Into Harvest Before Water Contact With The Ice Thickness Probe	22
---	----

Water Level Control Circuitry

Diagnosing Freeze Cycle Potable Water Level Control Circuitry	23
---	----

Water Trough Overflowing During The Freeze Cycle	24
--	----

Water Will Not Run Into The Sump Trough During The Freeze Cycle	26
---	----

Diagnosing Ice Machine That Will Not Run.....	27
---	----

Table of Contents

Refrigeration System

Sequence of Operation

Self-Contained Water-Cooled Models	28
--	----

Operational Analysis (Diagnostics)

General.....	29
--------------	----

Before Beginning Service	30
--------------------------------	----

Ice Production Check	30
----------------------------	----

Installation/Visual Inspection Checklist	31
--	----

Water System Checklist	31
------------------------------	----

Ice Formation Pattern	32
-----------------------------	----

Safety Limits.....	34
--------------------	----

Hot Gas Valve Temperature Check	37
---------------------------------------	----

Analyzing Discharge Pressure During Freeze or Harvest Cycle

Procedure.....	38
----------------	----

Freeze Cycle Discharge Pressure High Checklist	38
--	----

Freeze Cycle Discharge Pressure Low Checklist	38
---	----

Analyzing Suction Pressure During Freeze Cycle

Procedure.....	39
----------------	----

Freeze Cycle Suction Pressure High Checklist	40
--	----

Freeze Cycle Suction Pressure Low Checklist	40
---	----

How to Use the Refrigeration System Operational Analysis Tables.....	41
--	----

Refrigeration System Operational Analysis Table

Dual TXV.....	42
---------------	----

Pressure Control Specifications and Diagnostics

High Pressure Cutout (HPCO) Control.....	43
--	----

Cycle Time/24 Hour Ice Production/Refrigerant Pressure Charts

Q1300	44
-------------	----

Refrigerant Recovery/Evacuating and Recharging

Normal Self-Contained Model Procedures.....	45
---	----

System Contamination Cleanup	47
------------------------------------	----

Replacing Pressure Controls Without Removing Refrigerant Charge	49
---	----

Filter-Driers.....	51
--------------------	----

Total System Refrigerant Charges	51
--	----

Refrigerant Definitions.....	52
------------------------------	----

Refrigerant Re-Use Policy	53
---------------------------------	----

HFC Refrigerant Questions and Answers	54
---	----

Electrical System

Energized Parts Charts

SELF-CONTAINED WATER-COOLED MODELS

Ice Making Sequence Of Operation	Control Board Relays						Length Of Time
	1	2	3	4	5	5A	
	Water Pump	Water Fill Valve	Hot Gas Valve(s)	Water Dump Valve	Contactor Coil	Compressor	
Start-Up¹							
1. Water Purge	On	Off	On	On	Off	Off	45 Seconds
2. Refrigeration System Start-Up	Off	On	On	Off	On	On	5 Seconds
Freeze Sequence							
3. Pre-Chill	Off	May cycle On/Off during first 45 sec. ----- Cycles On, then Off 1 more time	Off	Off	On	On	30 Seconds
Freeze	On		Off	Off	On	On	Until 7 sec. water contact with ice thickness probe
Harvest Sequence							
5. Water Purge	On	30 sec. Off, 15 sec. On	On	On	On	On	Factory-set at 45 Seconds
6. Harvest	Off	Off	On	Off	On	On	Bin switch activation
7. Automatic Shut-Off	Off	Off	Off	Off	Off	Off	Until bin switch re-closes

¹Initial Start-Up or Start-Up After Automatic Shut-Off

Harvest Water Purge

The circuit board has an adjustable water purge in the harvest cycle. This permits a 15, 30 or 45 second purge cycle.

Auto Shut-Off

The ice machine remains off for 3 minutes before it can automatically restart. The ice machine restarts (steps 1-2) immediately after the delay period, if the bin switch re-closes prior to 3 minutes.

Safety Timers

The control board has the following non-adjustable safety timers:

FREEZE SEQUENCE

- The ice machine is locked into the freeze cycle for the first 6 minutes, not allowing the ice thickness probe to initiate a harvest sequence.
- The maximum freeze time is 60 minutes, at which time the control board automatically initiates a harvest sequence (steps 5-6).

HARVEST SEQUENCE

The maximum harvest time is 3-1/2 minutes, at which time the control board automatically terminates the harvest sequence. If the bin switch is open, the ice machine will go to automatic shut-off (step7). If the bin switch is closed, the ice machine will go to the freeze sequence (steps 3-4).

Electrical System

Wiring Diagram Sequence of Operation

SELF-CONTAINED MODELS

Initial Start-Up or Start-Up After Automatic Shut-Off

1. WATER PURGE

Before the compressor starts, the water pump and water dump solenoid are energized for 45 seconds to purge old water from the ice machine. This ensures that the ice-making cycle starts with fresh water.

The hot gas valve(s) is also energized during the water purge. In the case of an initial refrigeration start-up, it stays on for an additional 5 seconds (50 seconds total).

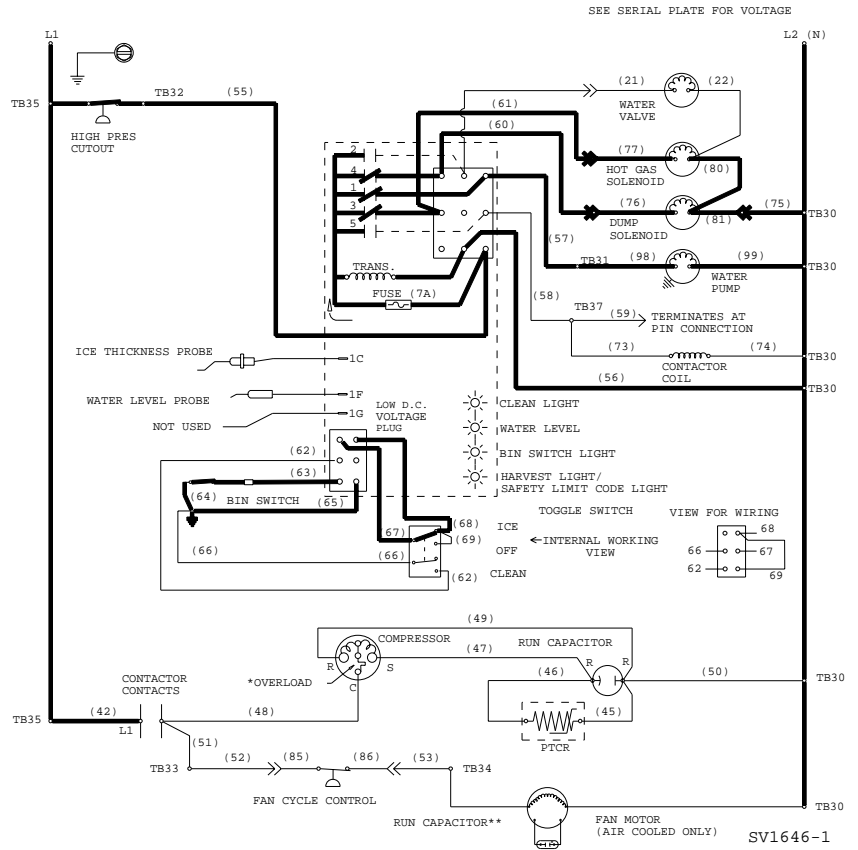

Self-Contained Models

1. Water Purge (45 Seconds)

Toggle Switch	ICE
Bin Switch	Closed
Control Board Relays	
#1 Water Pump	Closed / ON
#2 Water Fill Valve	Open / OFF
#3 Hot Gas Solenoid	Closed / ON
#4 Water Dump Valve	Closed / ON
#5 Contactor Coil	Open / OFF
Compressor	OFF
Safety Controls (Which could stop ice machine operation)	
High Pressure Cut-Out	Closed
Main Fuse (On Control Board)	Closed

Initial Start-Up Or Start-Up After Automatic Shut-Off (cont.)

2. REFRIGERATION SYSTEM START-UP

The compressor starts after the 45-second water purge, and it remains on throughout the Freeze and Harvest cycles.

The water fill valve is energized at the same time as the compressor. It remains on until the water level sensor closes for 3 continuous seconds.

The hot gas valve(s) remains on for the first 5 seconds of the initial compressor start-up.

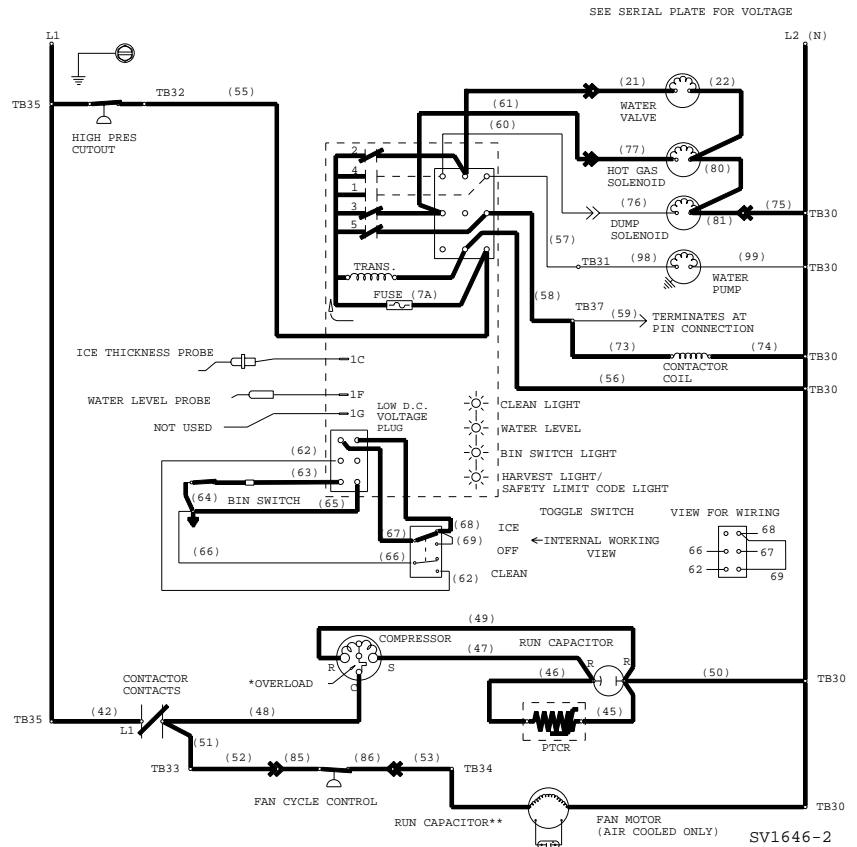

Self-Contained Models

2. Refrigeration System Start-Up (5 Seconds)

Toggle Switch	ICE
Bin Switch	Closed
Control Board Relays	
#1 Water Pump	Open / OFF
#2 Water Fill Valve	Closed / ON
#3 Hot Gas Solenoid	Closed / ON
#4 Water Dump Valve	Open / OFF
#5 Contactor Coil	Closed / ON
Compressor	ON
Safety Controls (Which could stop ice machine operation)	
High Pressure Cut-Out	Closed
Main Fuse (On Control Board)	Closed

Electrical System

Freeze Sequence

3. PRE-CHILL

To pre-chill the evaporator, the compressor runs for 30 seconds prior to water flow.

The water fill valve remains on until the water level sensor closes for three continuous seconds.

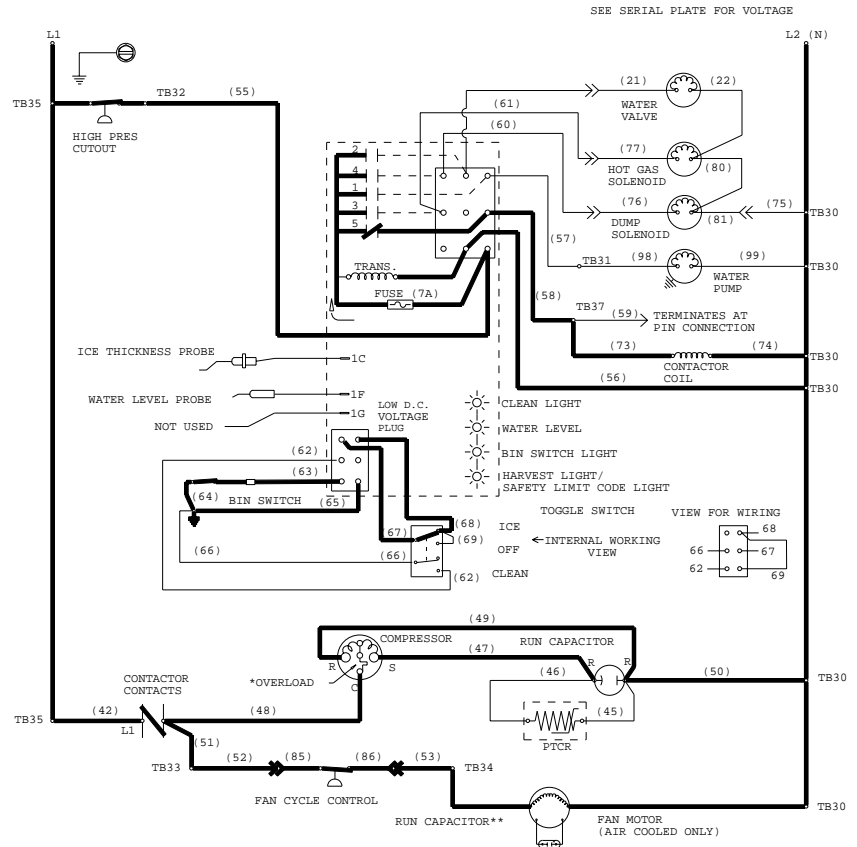

Self-Contained Models

3. Pre-Chill (30 Seconds)

Toggle Switch	ICE
Bin Switch	Closed
Control Board Relays	
#1 Water Pump	Open / OFF
#2 Water Fill Valve	Closed / ON
#3 Hot Gas Solenoid	Open / OFF
#4 Water Dump Valve	Open / OFF
#5 Contactor Coil	Closed / ON
Compressor	ON
Safety Controls (Which could stop ice machine operation)	
High Pressure Cut-Out	Closed
Main Fuse (On Control Board)	Closed

Freeze Sequence (cont.)

4. FREEZE

The water pump starts after the 30-second pre-chill. An even flow of water is directed across the evaporator and into each cube cell, where it freezes.

When sufficient ice has formed, the water flow (not the ice) contacts the ice thickness probes. After approximately 7 seconds of continual contact, a harvest cycle is initiated.

NOTE: The ice machine cannot initiate a harvest cycle until a 6-minute freeze lock has expired.

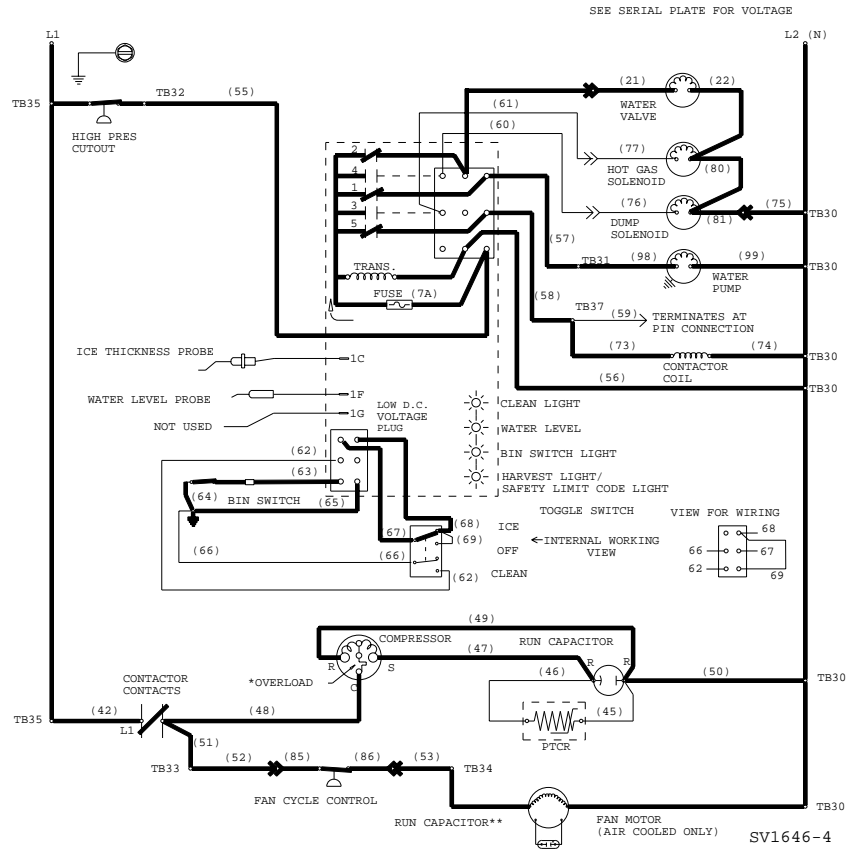

Self-Contained Models

4. Freeze (Until 7 Seconds of Water Contact with Ice Thickness Probe)	
Toggle Switch	ICE
Bin Switch	Closed
Control Board Relays	
#1 Water Pump	Closed / ON
#2 Water Fill Valve	Cycles ON then OFF
#3 Hot Gas Solenoid	Open / OFF
#4 Water Dump Valve	Open / OFF
#5 Contactor Coil	Closed / ON
Compressor	ON
Safety Controls (Which could stop ice machine operation)	
High Pressure Cut-Out	Closed
Main Fuse (On Control Board)	Closed

Electrical System

Harvest Sequence

5. WATER PURGE

The water pump continues to run, and the water dump valve energizes for 45 seconds to purge the water in the sump trough. The water fill valve energizes (turns on) and de-energizes (turns off) strictly by time. The water fill valve energizes for the last 15 seconds of the 45-second water purge. The water purge must be at the factory setting of 45 seconds for the fill valve to energize during the last 15 seconds of the Water Purge. If set at less than 45 seconds, the water fill valve does not energize during the water purge.

After the 45 second water purge, the water fill valve, water pump and dump valve de-energize. (Refer to "Water Purge Adjustment for details.) The hot gas valve also opens at the beginning of the water purge to divert hot refrigerant gas into the evaporator.

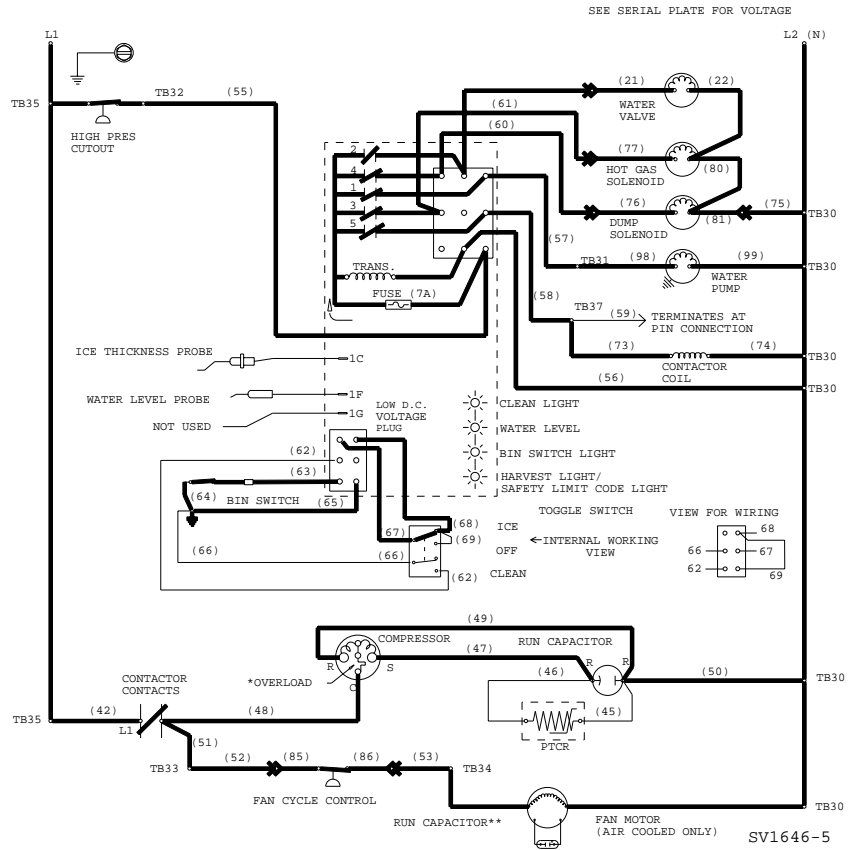

Self-Contained Models

5. Water Purge (45 Seconds)	
Toggle Switch	ICE
Bin Switch	Closed
Control Board Relays	
#1 Water Pump	Closed / ON
#2 Water Fill Valve	Cycles OFF then ON
#3 Hot Gas Solenoid	Closed / ON
#4 Water Dump Valve	Closed / ON
#5 Contactor Coil	Closed / ON
Compressor	ON
Safety Controls (Which could stop ice machine operation)	
High Pressure Cut-Out	Closed
Main Fuse (On Control Board)	Closed

Harvest Sequence (cont.)

6. HARVEST

The hot gas valve(s) remains open, allowing refrigerant gas to warm the evaporator. This causes the cubes to slide, as a sheet, off the evaporator and into the storage bin.

The sliding sheet of cubes swings the water curtain out, opening the bin switch. This momentary opening and closing of the bin switch terminates the Harvest Cycle and returns the ice machine to the Freeze Cycle (steps 3-4).

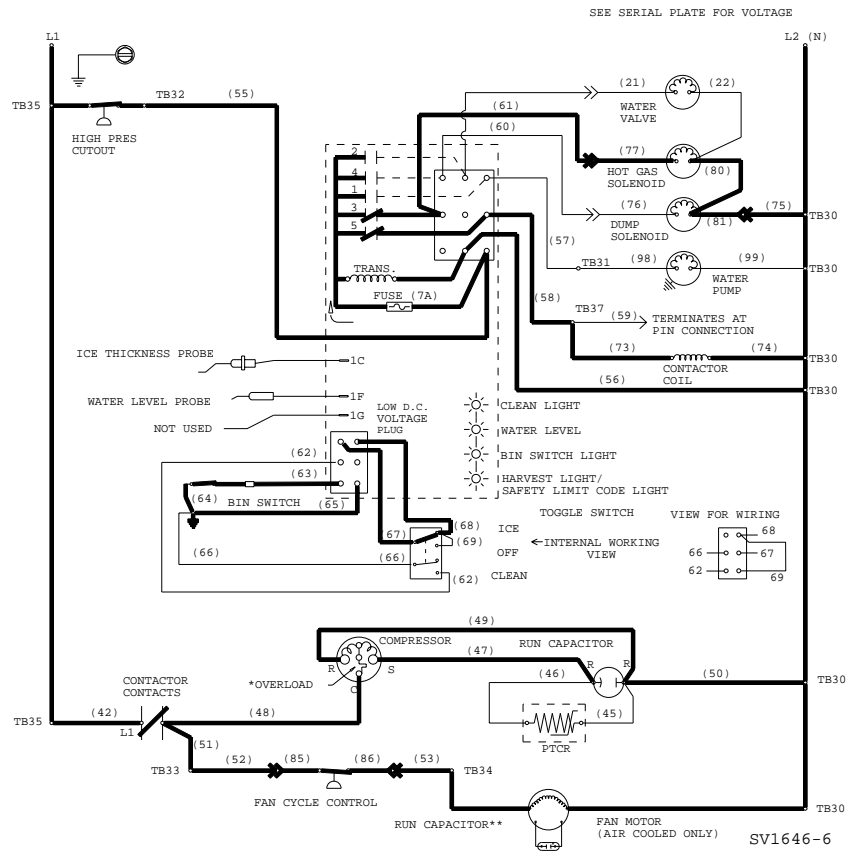

Self-Contained Models

6. Harvest (Until Bin Switch Activation)

Toggle Switch	ICE
Bin Switch	Closed
Control Board Relays	
#1 Water Pump	Open / OFF
#2 Water Fill Valve	Open / OFF
#3 Hot Gas Solenoid	Closed / ON
#4 Water Dump Valve	Open / OFF
#5 Contactor Coil	Closed / ON
Compressor	ON
Safety Controls (Which could stop ice machine operation)	
High Pressure Cut-Out	Closed
Main Fuse (On Control Board)	Closed

Electrical System

7. Automatic Shut-Off

If the storage bin is full at the end of a harvest cycle, the sheet of cubes fails to clear the water curtain and holds it open. After the water curtain is held open for 7 seconds, the ice machine shuts off.

The ice machine remains off until enough ice is removed from the storage bin to allow the sheet of cubes to drop clear of the water curtain. As the water curtain swings back to the operating position, the bin switch closes and the ice machine restarts (steps 1-2).

NOTE: The ice machine must remain off for 3 minutes before it can automatically restart.

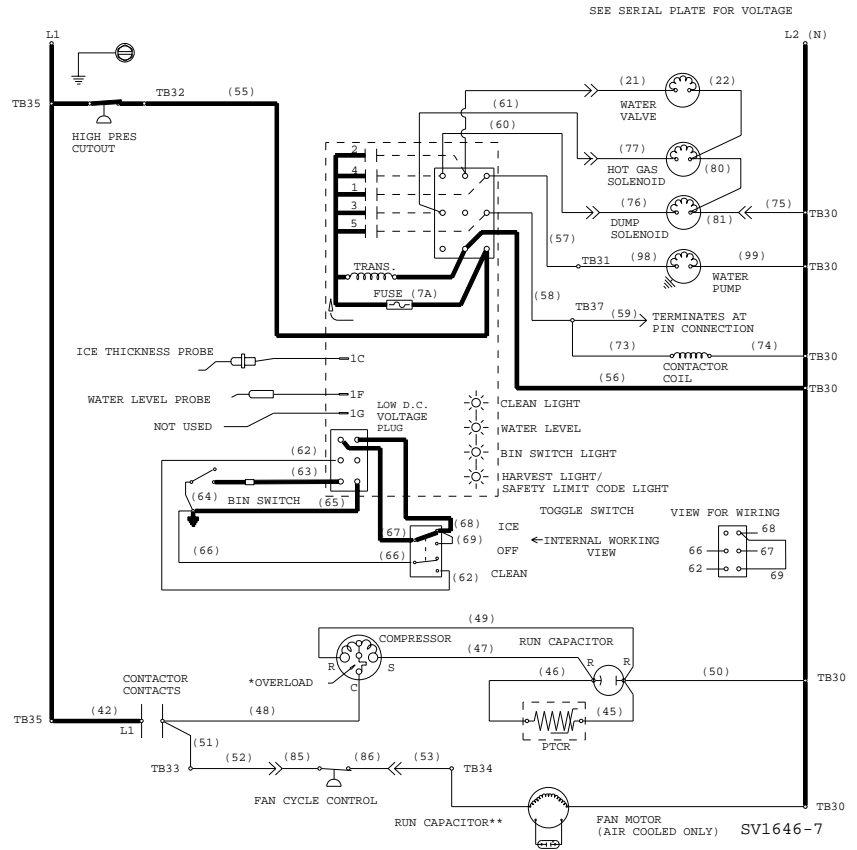

Self-Contained Models

7. Automatic Shut-Off (Until Bin Switch Closes)	
Toggle Switch	ICE
Bin Switch	Open
Control Board Relays	
#1 Water Pump	Open / OFF
#2 Water Fill Valve	Open / OFF
#3 Hot Gas Solenoid	Open / OFF
#4 Water Dump Valve	Open / OFF
#5 Contactor Coil	Open / OFF
Compressor	OFF
Safety Controls (Which could stop ice machine operation)	
High Pressure Cut-Out	Closed
Main Fuse (On Control Board)	Closed

Wiring Diagrams

The following pages contain electrical wiring diagrams. Be sure you are referring to the correct diagram for the ice machine which you are servicing.



WARNING

Always disconnect power before working on electrical circuitry.

WIRING DIAGRAM LEGEND

The following symbols are used on all of the wiring diagrams:

- * Internal Compressor Overload
(Some models have external compressor overloads)

- TB** Terminal Board Connection
(Terminal board numbers are printed on the actual terminal board)

- () Wire Number Designation
(The number is marked at each end of the wire)

- >>— Multi-Pin Connection
(Electrical Box Side) —>>— (Compressor Compartment Side)

Electrical System

Q1300 - 1 PHASE

CAUTION: DISCONNECT POWER BEFORE WORKING ON ELECTRICAL CIRCUITRY.

NOTE: DIAGRAM SHOWN DURING FREEZE CYCLE.

SEE SERIAL PLATE FOR VOLTAGE

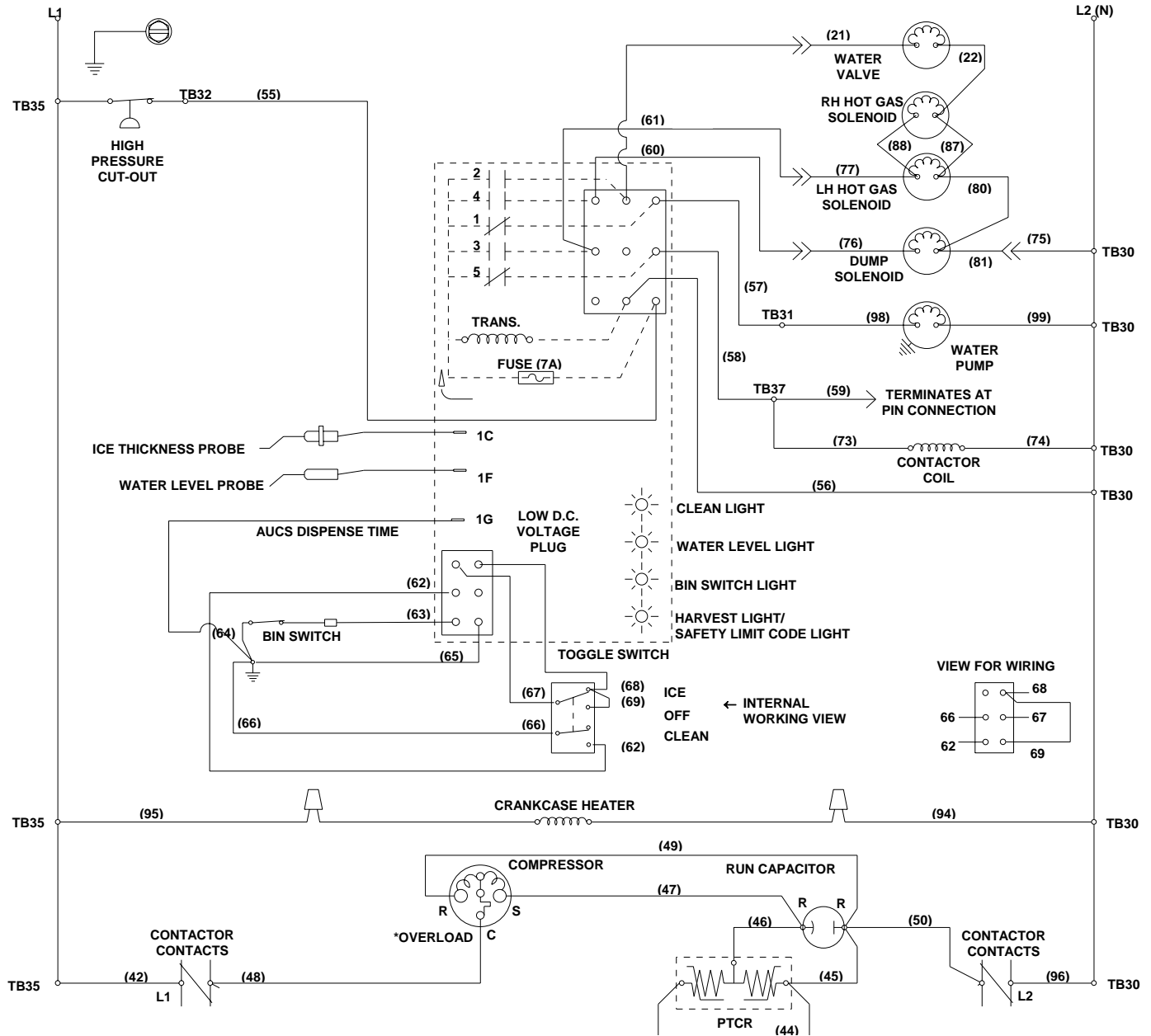

SV1652

Component Specifications and Diagnostics

MAIN FUSE

Function

The control board fuse stops ice machine operation if electrical components fail causing high amp draw.

Specifications

The main fuse is 250 Volt, 7 amp.

Check Procedure

 **WARNING**

High (line) voltage is applied to the control board (terminals #55 and #56) at all times. Removing the control board fuse or moving the toggle switch to OFF will not remove the power supplied to the control board.

1. If the bin switch light is on with the water curtain closed, the fuse is good.

 **WARNING**

Disconnect electrical power to the entire ice machine before proceeding.

2. Remove the fuse. Check the resistance across the fuse with an ohm meter.

Reading	Result
Open (OL)	Replace fuse
Closed (O)	Fuse is good

BIN SWITCH

Function

Bin switch operation is controlled by movement of the water curtain. The bin switch has two main functions:

1. Terminating the harvest cycle and returning the ice machine to the freeze cycle.

This occurs when the bin switch is opened and closed again within 7 seconds during the harvest cycle.

2. Automatic ice machine shut-off.

If the storage bin is full at the end of a harvest cycle, the sheet of cubes fails to clear the water curtain and holds it open. After the water curtain is held open for 7 seconds, the ice machine shuts off.

The ice machine remains off until enough ice is removed from the storage bin to allow the sheet of cubes to drop clear of the water curtain. As the water curtain swings back to the operating position, the bin switch closes and the ice machine restarts.

Important

The water curtain must be ON (bin switch closed) to start ice making.

Specifications

The bin switch is a magnetically operated reed switch. The magnet is attached to the lower right corner of the water curtain. The switch is attached to the evaporator mounting bracket.

The bin switch is connected to a varying D.C. voltage circuit. (Voltage does not remain constant.)

NOTE: Because of a wide variation in D.C. voltage, it is not recommended that a voltmeter be used to check bin switch operation.

Electrical System

Check Procedure

1. Set the toggle switch to OFF.
2. Watch the bin switch light on the control board.
3. Move the water curtain toward the evaporator. The bin switch must close. The bin switch light “on” indicates the bin switch has closed properly.
4. Move the water curtain away from the evaporator. The bin switch must open. The bin switch light “off” indicates the bin switch has opened properly.

Ohm Test

1. Disconnect the bin switch wires to isolate the bin switch from the control board.
2. Connect an ohmmeter to the disconnected bin switch wires. Set the ohmmeter to the 10,000 ohm scale.
3. Cycle the bin switch by opening and closing the water curtain.
4. With the bin switch open: Resistance readings of more than 30,000 ohms indicate a correctly operating bin switch.
5. With the bin switch closed: Resistance readings of less than 70 ohms indicates a correctly operating bin switch.

Important

Any reading between 70 and 30,000 ohms, regardless of curtain position, indicates a defective bin switch

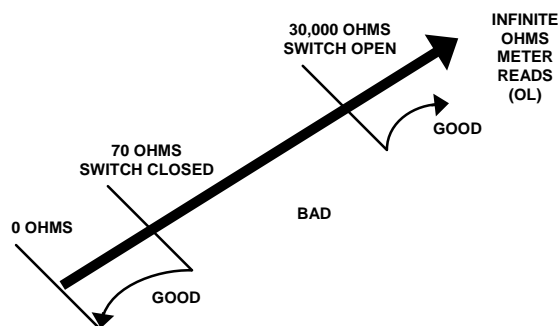

Bin Switch Resistance Readings

Water Curtain Removal Notes

The water curtain must be on (bin switch closed) to start ice making. While a freeze cycle is in progress, the water curtain can be removed and installed at any time without interfering with the electrical control sequence.

If the ice machine goes into harvest sequence while the water curtain is removed, one of the following will happen:

- Water curtain remains off
When the harvest cycle time reaches 3.5 minutes and the bin switch is not closed, the ice machine stops as though the bin were full.
- Water curtain is put back on
If the bin switch closes prior to reaching the 3.5 minute point, the ice machine immediately returns to another freeze sequence prechill.

COMPRESSOR ELECTRICAL DIAGNOSTICS

The compressor will not start or will trip repeatedly on overload.

Check Resistance (Ohm) Values

NOTE: Compressor windings can have very low ohm values. Use a properly calibrated meter.

Perform the resistance test after the compressor cools. The compressor dome should be cool enough to touch (below 120°F/49°C) to assure that the overload is closed and the resistance readings will be accurate.

SINGLE PHASE COMPRESSORS

1. Disconnect power from the cuber and remove the wires from the compressor terminals.
2. The resistance values must be within published guidelines for the compressor. The resistance values between C and S and between C and R, when added together, should equal the resistance value between S and R.
3. If the overload is open, there will be a resistance reading between S and R, and open readings between C and S and between C and R. Allow the compressor to cool, then check the readings again.

Check Motor Windings to Ground

Check continuity between all three terminals and the compressor shell or copper refrigeration line. Scrape metal surface to get good contact. If continuity is present, the compressor windings are grounded and the compressor should be replaced.

Determine if the Compressor is Seized

Check the amp draw while the compressor is trying to start.

COMPRESSOR DRAWING LOCKED ROTOR

The two likely causes of this are:

- Defective starting component
- Mechanically seized compressor

To determine which you have:

1. Install high and low side gauges.
2. Try to start the compressor.
3. Watch the pressures closely.
 - A. If the pressures do not move, the compressor is seized. Replace the compressor.
 - B. If the pressures move, the compressor is turning slowly and is not seized. Check the capacitors and start relay.

COMPRESSOR DRAWING HIGH AMPS

The continuous amperage draw on start-up should not be near the maximum fuse size indicated on the serial tag.

The voltage when the compressor is trying to start must be within $\pm 10\%$ of the nameplate voltage.

Diagnosing Capacitors

- If the compressor attempts to start, or hums and trips the overload protector, check the starting components before replacing the compressor.
- Visual evidence of capacitor failure can include a bulged terminal end or a ruptured membrane. Do not assume a capacitor is good if no visual evidence is present.
- A good test is to install a known good substitute capacitor.
- Use a capacitor tester when checking a suspect capacitor. Clip the bleed resistor off the capacitor terminals before testing.

Diagnosing PTCR's

See "PTCR Diagnostics" on the next page.

PTCR DIAGNOSTICS

What is a PTCR?

A PTCR (or Positive Temperature Coefficient Resistor) is made from high-purity, semi-conducting ceramics.

A PTCR is useful because of its resistance versus temperature characteristic. The PTCR has a low resistance over a wide (low) temperature range, but upon reaching a certain higher temperature, its resistance greatly increases, virtually stopping current flow. When the source of heat is removed, the PTCR returns to its initial base resistance.

In severe duty cycles, it can be used to repeatedly switch (virtually stop) large currents at line voltages.

PTCR's have been used for many years in millions of HVAC applications. In place of using the conventional start relay/start capacitor, a simple PTCR provides the starting torque assistance to PSC (Permanent Split Capacitor) single-phase compressors, which can equalize pressures before starting.

Compressor Start Sequence

PTCR's provide additional starting torque by increasing the current in the auxiliary (start) winding during starting. The PTCR is wired across the run capacitor (in series with the start winding).

1. It is important for the refrigerant discharge and suction pressures to be somewhat equalized prior to the compressor starting. To assure equalization of pressures the hot gas valve (and HPR valve on remotes) will energize for 45 seconds prior to compressor starting. The hot gas valve (and HPR valve on remotes) remains on for an additional 5 seconds while the compressor is starting.
2. When starting the compressor, the contactor closes and the PTCR, which is at a low resistance value, allows high starting current to flow in the start winding.
3. The current passing through the PTCR causes it to rapidly heat up, and after approximately .25-1 second it abruptly "switches" to a very high resistance, virtually stopping current flow through it.
4. At this point the motor is up to speed and all current going through the start winding will now pass through the run capacitor.
5. The PTCR remains hot and at a high resistance as long as voltage remains on the circuit.
6. It is important to provide time between compressor restarts to allow the PTCR to cool down to near its initial temperature (low resistance). When the contactor opens to stop the compressor, the PTCR cools down to its initial low resistance and is again ready to provide starting torque assistance. To assure the PTCR has cooled down, during an automatic shut-off, the Q model ice machines have a built-in 3-minute off time before it can restart.

Q-Model Automatic Shut-Off and Restart

When the storage bin is full at the end of a harvest cycle, the sheet of cubes fails to clear the water curtain and will hold it open. After the water curtain is held open for 7 seconds, the ice machine shuts off. To assure the PTCR has cooled, the ice machine remains off for 3 minutes before it can automatically restart.

The ice machine remains off until enough ice has been removed from the storage bin to allow the ice to fall clear of the water curtain. As the water curtain swings back to operating position, the bin switch closes and the ice machine restarts, provided the three-minute delay period is complete.

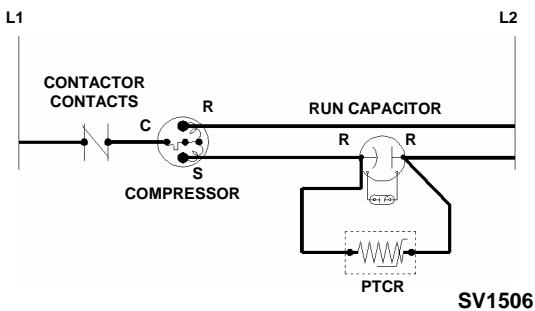

During Start-Up (First .25 - 1.0 Seconds)

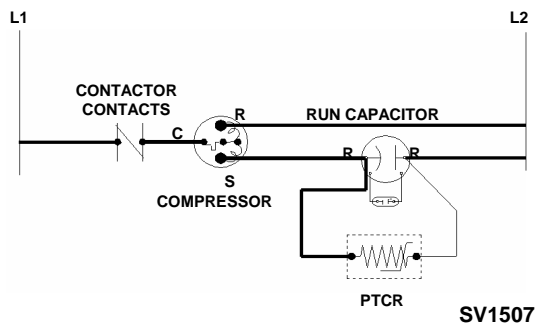

After Start-Up (Current Flows Through Run Capacitor)

Troubleshooting PTCR's

WHY A GOOD PTCR MAY FAIL TO START THE COMPRESSOR

The PTCR must be cooled before attempting to start the compressor, otherwise the high starting torque may not last long enough.

For example, if the PTCR is properly cooled, say 60°F (15.6°C) when the compressor starts, it will take .25 to 1.0 seconds before its temperature reaches 260°F (126.6°C), and current flow is stopped.

If the PTCR is still warm, say 160°F (71.1°C) when the compressor starts, it will take only .125 to .50 seconds before its temperature reaches 260°F (126.6°C), and current flow is stopped. This decreased time may be insufficient to start the compressor.

A good PTCR may be too hot to operate properly at start-up because:

- The ice machine's 3-minute delay has been overridden. Opening and closing the service disconnect or cycling the toggle switch from OFF to ICE will override the delay period.
- The control box temperature is too high. Though rare, very high air temperatures (intense sunlight, etc.) can greatly increase the temperature of the control box and its contents. This may require a longer off time to allow the PTCR to cool.
- The compressor has short-cycled, or the compressor overload has opened. Move the toggle switch to OFF and allow the compressor and PTCR to cool.

Continued on next page...

Electrical System

There are other problems that may cause compressor start-up failure with a good PTCR in a new, properly wired ice machine.

- The voltage at the compressor during start-up is too low.

Manitowoc ice machines are rated at $\pm 10\%$ of nameplate voltage at compressor start-up. (Ex: An ice machine rated at 208-230 should have a compressor start-up voltage between 187 and 253 volts.)

- The compressor discharge and suction pressures are not matched closely enough or equalized.

These two pressures must be somewhat equalized before attempting to start the compressor. The hot gas valve (and HPR valve on remotes) energizes for 45 seconds before the compressor starts, and remains on 5 seconds after the compressor starts. Make sure this is occurring before assuming that the PTCR is bad.

Model	Manitowoc Part Number	Cera-Mite Part Number	Room Temperature Resistance
Q1300	8504913	305C9	8-22 Ohms

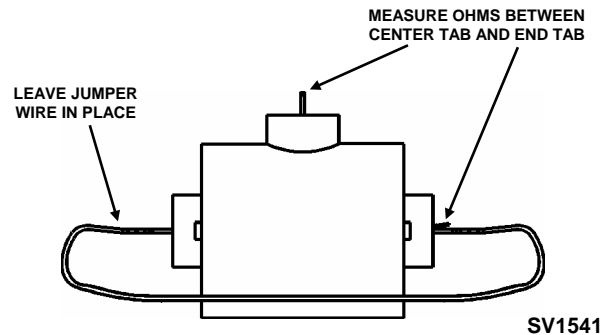

Manitowoc PTCR 8504913

CHECKING THE PTCR

⚠ WARNING

Disconnect electrical power to the entire ice machine at the building electrical disconnect box before proceeding.

1. Visually inspect the PTCR. Check for signs of physical damage.

NOTE: The PTCR case temperature may reach 210°F (100°C) while the compressor is running. This is normal. Do not change a PTCR just because it is hot.

2. Wait at least 10 minutes for the PTCR to cool to room temperature.
3. Remove the PTCR from the ice machine.
4. Measure the resistance of the PTCR as shown below. If the resistance falls outside of the acceptable range, replace it.

ICE/OFF/CLEAN TOGGLE SWITCH

Function

The switch is used to place the ice machine in ICE, OFF or CLEAN mode of operation.

Specifications

Double-pole, double-throw switch. The switch is connected into a varying low D.C. voltage circuit.

Check Procedure

NOTE: Because of a wide variation in D.C. voltage, it is not recommended that a voltmeter be used to check toggle switch operation.

1. Inspect the toggle switch for correct wiring.
2. Isolate the toggle switch by disconnecting all wires from the switch, or by disconnecting the Molex connector and removing wire #69 from the toggle switch.
3. Check across the toggle switch terminals using a calibrated ohm meter. Note where the wire numbers are connected to the switch terminals, or refer to the wiring diagram to take proper readings.

Switch Setting	Terminals	Ohm Reading
ICE	66-62	Open
	67-68	Closed
	67-69	Open
CLEAN	66-62	Closed
	67-68	Open
	67-69	Closed
OFF	66-62	Open
	67-68	Open
	67-69	Open

4. Replace the toggle switch if ohm readings do not match all three switch settings.

CONTROL BOARD RELAYS

Function

The control board relays energize and de-energize system components.

Specifications

Relays are not field replaceable. There are five relays on the control board:

Relay	Controls
#1	Water Pump
#2	Water Inlet Valve
#3	Hot Gas Valve
#4	Water Dump Valve
#5	Contactors (Self-Contained) Contactors / Liquid Line Solenoid (Remotes)

Electrical System

ELECTRONIC CONTROL BOARD

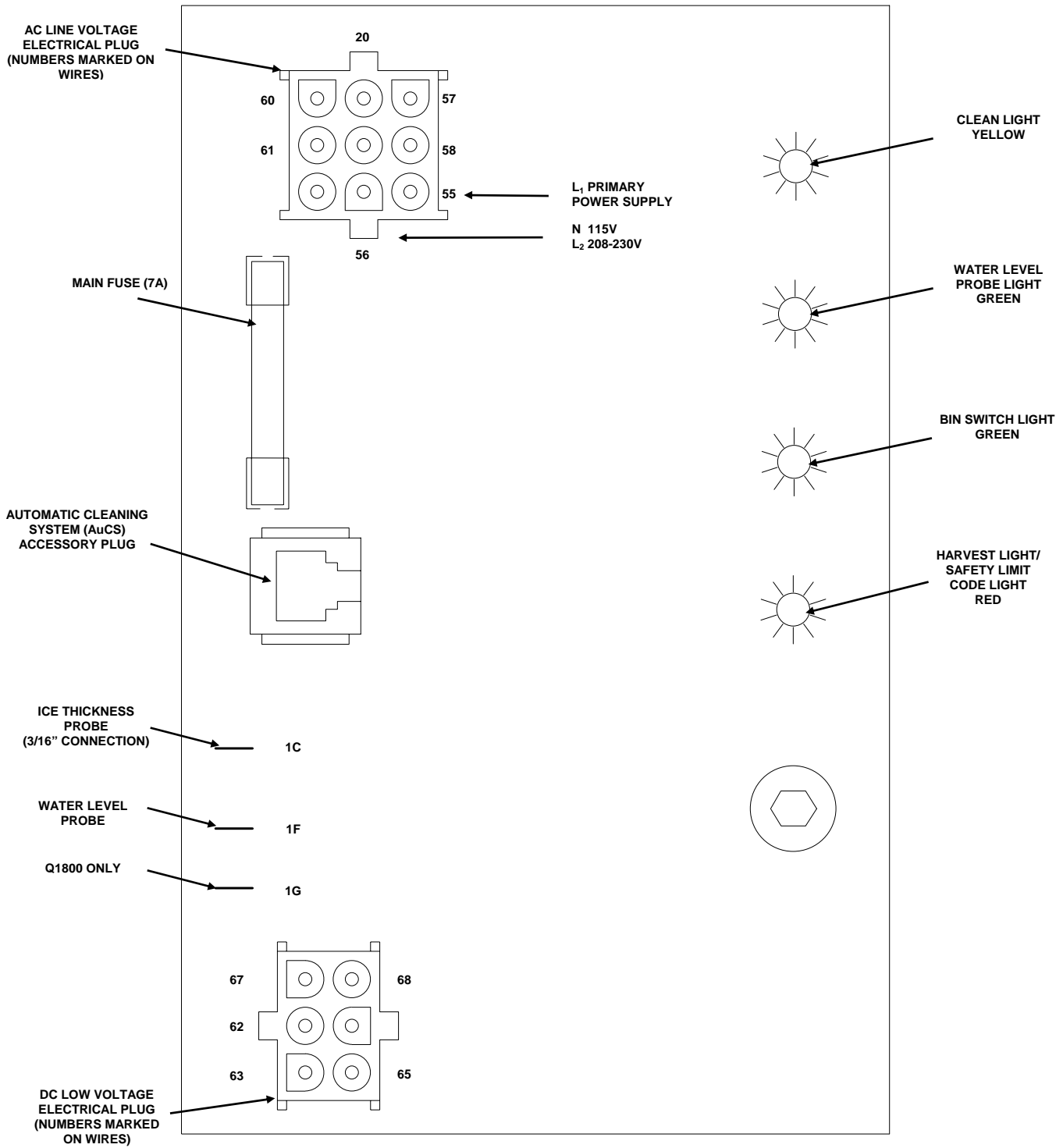

SV1588

Control Board

General

Q-Model control boards use a dual voltage transformer. This means only one control board is needed for both 115V and 208-230V use.

Safety Limits

In addition to standard safety controls, such as the high pressure cut-out, the control board has built-in safety limits.

These safety limits protect the ice machine from major component failures. For more information, see “Safety Limits”.

Inputs

The control board, along with inputs, controls all electrical components, including the ice machine sequence of operation. Prior to diagnosing, you must understand how the inputs affect the control board operation.

Refer to specific component specifications (inputs), wiring diagrams and ice machine sequence of operation sections for details.

As an example, refer to “Ice Thickness Probe” in the component specifications section of this manual for information relating to how the probe and control board function together.

This section will include items such as:

- How a harvest cycle is initiated
- How the harvest light functions with the probe
- Freeze time lock-in feature
- Maximum freeze time
- Diagnosing ice thickness control circuitry

Electrical System

Ice Thickness Probe (Harvest Initiation)

HOW THE PROBE WORKS

Manitowoc's electronic sensing circuit does not rely on refrigerant pressure, evaporator temperature, water levels or timers to produce consistent ice formation.

As ice forms on the evaporator, water (not ice) contacts the ice thickness probe. After the water completes this circuit across the probe continuously for 6-10 seconds, a harvest cycle is initiated.

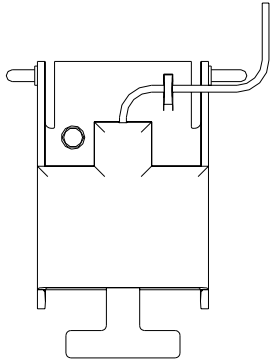

SV1729A

Ice Thickness Probe

HARVEST/SAFETY LIMIT LIGHT

This light's primary function is to be on as water contacts the ice thickness probe during the freeze cycle, and remain on throughout the entire harvest cycle. The light will flicker as water splashes on the probes.

The light's secondary function is to continuously flash when the ice machine is shut off on a safety limit, and to indicate which safety limit shut off the ice machine.

FREEZE TIME LOCK-IN FEATURE

The ice machine control system incorporates a freeze time lock-in feature. This prevents the ice machine from short cycling in and out of harvest.

The control board locks the ice machine in the freeze cycle for six minutes. If water contacts the ice thickness probe during these six minutes, the harvest light will come on (to indicate that water is in contact with the probe), but the ice machine will stay in the freeze cycle. After the six minutes are up, a harvest cycle is initiated. This is important to remember when performing diagnostic procedures on the ice thickness control circuitry.

To allow the service technician to initiate a harvest cycle without delay, this feature is not used on the first cycle after moving the toggle switch OFF and back to ICE.

MAXIMUM FREEZE TIME

The control system includes a built-in safety which will automatically cycle the ice machine into harvest after 60 minutes in the freeze cycle.

ICE THICKNESS CHECK

The ice thickness probe is factory-set to maintain the ice bridge thickness at 1/8" (3.2 mm).

NOTE: Make sure the water curtain is in place when performing this check. It prevents water from splashing out of the water trough.

1. Inspect the bridge connecting the cubes. It should be about 1/8" (3.2 mm) thick.
2. If adjustment is necessary, turn the ice thickness probe adjustment screw clockwise to increase bridge thickness, or counterclockwise to decrease bridge thickness.

NOTE: Turning the adjustment 1/3 of a turn will change the ice thickness about 1/16" (1.5 mm).

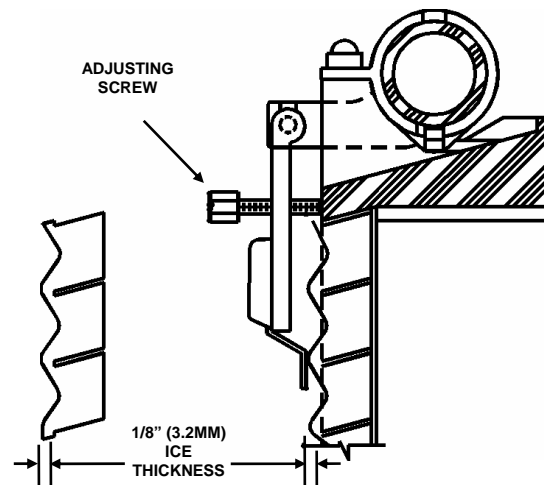

Ice Thickness Check SV1208

Make sure the ice thickness probe wire and the bracket do not restrict movement of the probe.

DIAGNOSING ICE THICKNESS CONTROL CIRCUITRY

Ice Machine Does Not Cycle Into Harvest when Water Contacts the Ice Thickness Control Probe

Step 1 Bypass the freeze time lock-in feature by moving the ICE/OFF/CLEAN switch to OFF and back to ICE. Wait until the water starts to flow over the evaporator.

Step 2 Clip the jumper wire leads to the ice thickness probe and any cabinet ground.

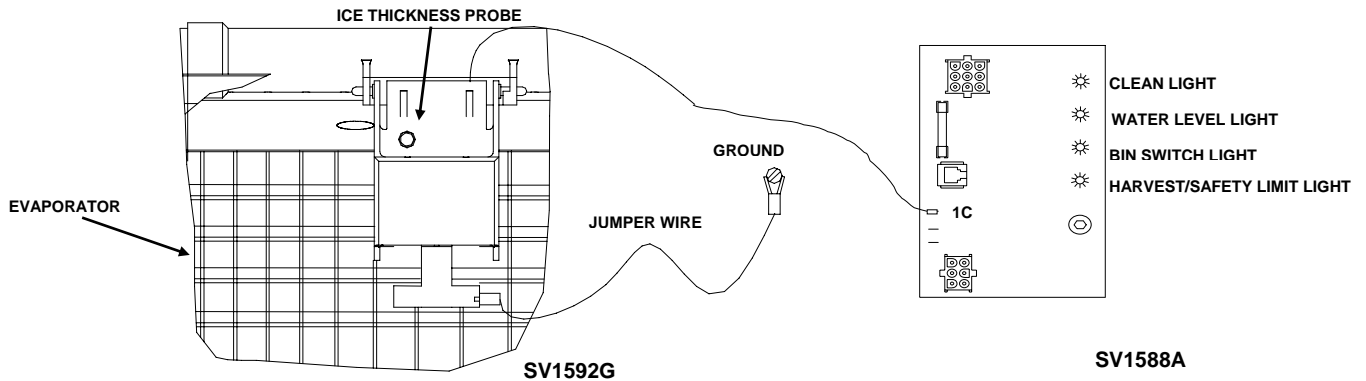

Step 2

Step 2 Jumper wire connected from probe to ground	
Monitoring of Harvest Light	Correction
The harvest light comes on, and 6-10 seconds later, ice machine cycles from freeze to harvest.	The ice thickness control circuitry is functioning properly. Do not change any parts.
The harvest light comes on but the ice machine stays in the freeze sequence.	The ice thickness control circuitry is functioning properly. The ice machine is in a six-minute freeze time lock-in. Verify step 1 of this procedure was followed correctly.
The harvest light does not come on.	Proceed to Step 3, below.

Step 3 Disconnect the ice thickness probe from the control board at terminal 1C. Clip the jumper wire leads to terminal 1C on the control board and any cabinet ground. Monitor the harvest light.

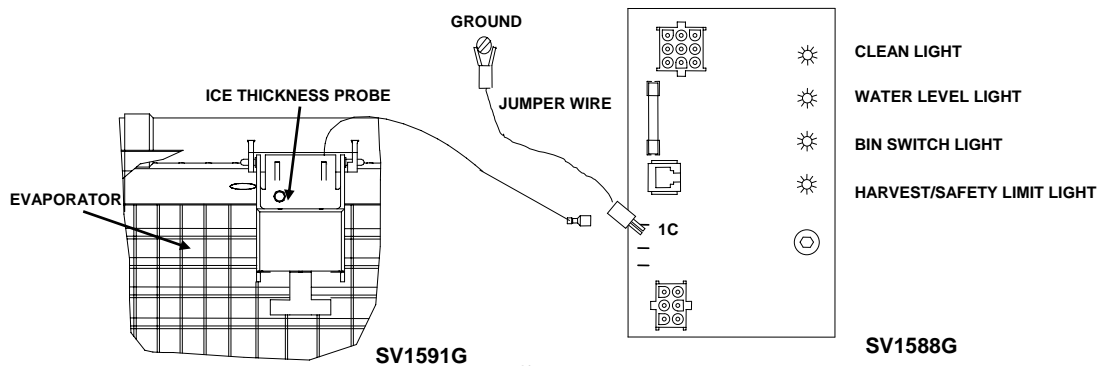

Step 3

Step 3 Jumper wire connected from control board terminal 1C to ground	
Monitoring of Harvest Light	Correction
The harvest light comes on, and 6-10 seconds later, ice machine cycles from freeze to harvest.	The ice thickness probe is causing the malfunction.
The harvest light comes on but the ice machine stays in the freeze sequence.	The control circuitry is functioning properly. The ice machine is in a six-minute freeze time lock-in (verify step 1 of this procedure was followed correctly).
The harvest light does not come on.	The control board is causing the malfunction.

Electrical System

Ice Machine Cycles Into Harvest Before Water Contact With The Ice Thickness Probe

Step 1 Disconnect the ice thickness probe from the control board at terminal 1C.

Step 2 Bypass the freeze time lock-in feature by moving the ICE/OFF/CLEAN switch to OFF and back to ICE. Wait until the water starts to flow over the evaporator, then monitor the harvest light.

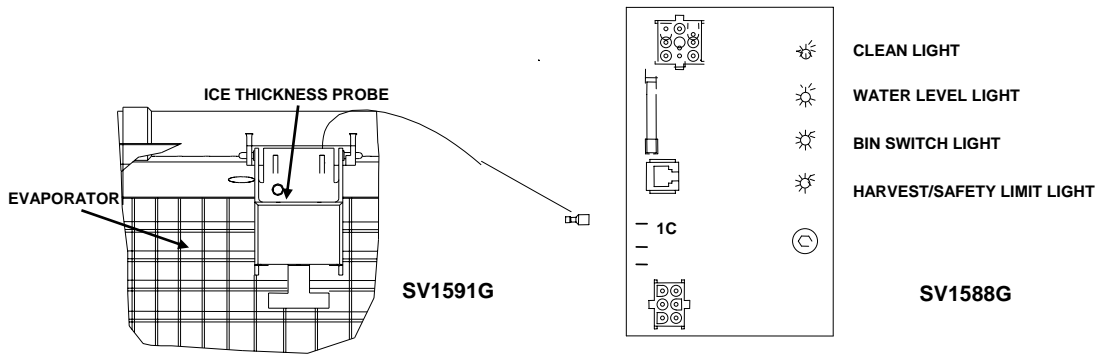

Step 2

Step 2 Disconnect probe from control board terminal 1C

Monitoring of Harvest Light	Correction
The harvest light stays off and the ice machine remains in the freeze sequence.	The ice thickness probe is causing the malfunction. Verify that the Ice Thickness probe is adjusted correctly.
The harvest light comes on, and 6-10 seconds later, the ice machine cycles from freeze to harvest.	The control board is causing the malfunction.

Water Level Control Circuitry

WATER LEVEL PROBE LIGHT

The water level probe circuit can be monitored by watching the water level light. The water level light is on when water contacts the probe, and off when no water is in contact with the probe. The water level light functions any time power is applied to the ice machine, regardless of toggle switch position.

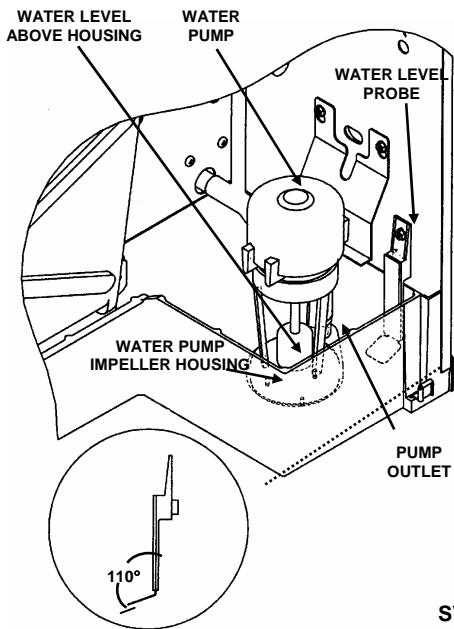

SV1616

Freeze Cycle Water Level Setting

During the freeze cycle, the water level probe is set to maintain the proper water level above the water pump housing. The water level is not adjustable. If the water level is incorrect, check the water level probe for damage (probe bent, etc.). Repair or replace the probe as necessary.

WATER INLET VALVE SAFETY SHUT-OFF

In the event of a water level probe failure, this feature limits the water inlet valve to a six-minute on time. Regardless of the water level probe input, the control board automatically shuts off the water inlet valve if it remains on for 6 continuous minutes. This is important to remember when performing diagnostic procedures on the water level control circuitry.

FREEZE CYCLE CIRCUITRY

Manitowoc's electronic sensing circuit does not rely on float switches or timers to maintain consistent water level control. During the freeze cycle, the water inlet valve energizes (turns on) and de-energizes (turns off) in conjunction with the water level probe located in the water trough.

During the first 45 seconds of the Freeze Cycle:

- The water inlet valve is **on** when there is no water in contact with the water level probe.
- The water inlet valve turns **off** after water contacts the water level probe for 3 continuous seconds.
- The water inlet valve will cycle on and off as many times as needed to fill the water trough.

After 45 seconds into the Freeze Cycle:

The water inlet valve will cycle on, and then off one more time to refill the water trough. The water inlet valve is now off for the duration of the freeze sequence.

HARVEST CYCLE CIRCUITRY

The water level probe does not control the water inlet valve during the harvest cycle. During the harvest cycle water purge, the water inlet valve energizes (turns on) and de-energizes (turns off) strictly by time. The harvest water purge adjustment dial may be set at 15, 30 or 45 seconds.

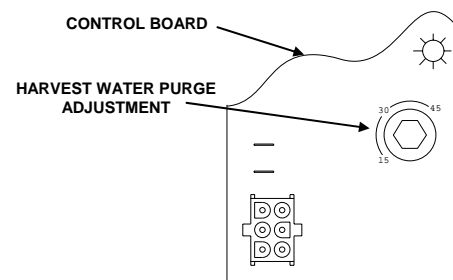

SV1617

NOTE: The water purge **must be at the factory setting** of 45 seconds for the water inlet valve to energize during the last 15 seconds of the Water Purge. If set at 15 or 30 seconds the water inlet valve will not energize during the harvest water purge.

Electrical System

DIAGNOSING FREEZE CYCLE POTABLE WATER LEVEL CONTROL CIRCUITRY

Problem: Water Trough Overflowing During The Freeze Cycle

Step 1 Start a new freeze sequence by moving the ICE/OFF/CLEAN toggle switch to OFF, then back to ICE.

Important

This restart must be done prior to performing diagnostic procedures. This assures the ice machine is not in a freeze cycle water inlet valve safety shut-off mode. You must complete the entire diagnostic procedure with-in 6 minutes of starting.

Step 2 **Wait until the freeze cycle starts** (approximately 45 seconds, the freeze cycle starts when the compressor energizes) then connect a jumper from the water level probe to any cabinet ground.

Important

For the test to work properly you must wait until the freeze cycle starts, prior to connecting the jumper wire. If you restart the test you must disconnect the jumper wire, restart the ice machine, (step 1) and then reinstall the jumper wire after the compressor starts.

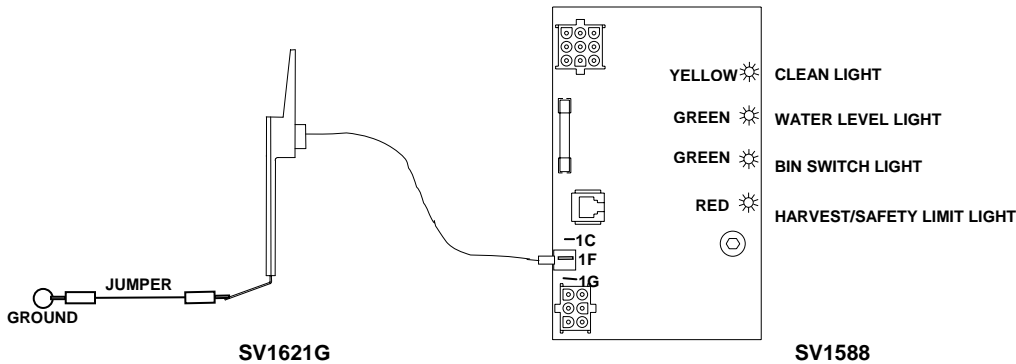

Step 2

Step 2 Jumper wire connected from probe to ground			
Is water flowing into the water trough?	The Water Level Light is:	The Water Inlet Valve Solenoid Coil is:	Cause
no	on	De-Energized	This is normal operation. Do not change any parts.
yes	on	De-Energized	The water inlet valve is causing the problem.
yes	off	Energized	Proceed to step 3.

Continued on next page...

Problem: Water Trough Overflowing During The Freeze Cycle (continued)

Step 3 Allow ice machine to run. Disconnect the water level probe from control board terminal 1F, and connect a jumper wire from terminal 1F to any cabinet ground.

Remember if you are past 6 minutes from starting, the ice machine will go into a freeze cycle water inlet valve safety shut-off mode, and you will be unable to complete this test. If past 6 minutes you must restart this test by disconnecting the jumper wire, restarting the ice machine, (step 1) and then reinstalling the jumper wire to terminal 1F, after the compressor starts.

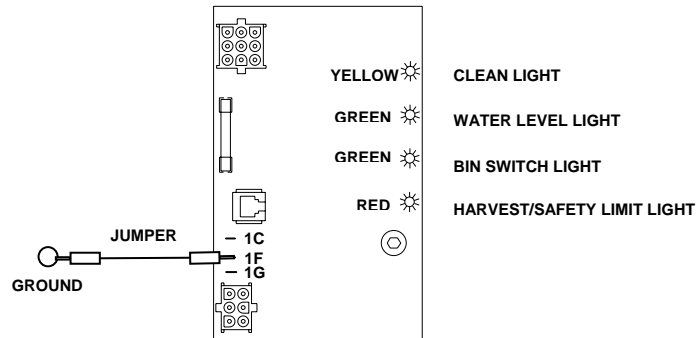

Step 3

Step 3 Jumper wire connected from control board terminal 1F to ground			
Is water flowing into the water trough?	The Water Level Light is:	The Water Inlet Valve Solenoid Coil is:	Cause
no	on	De-Energized	The water level probe is causing the problem. Clean or replace the water level probe.
yes	off	Energized	The control board is causing the problem.
yes	on	De-Energized	The water fill valve is causing the problem.

Electrical System

Problem: Water Will Not Run Into The Sump Trough During The Freeze Cycle

Step 1 Verify water is supplied to the ice machine, and then start a new freeze sequence by moving the ICE/OFF/CLEAN toggle switch to OFF then back to ICE.

Important

This restart must be done prior to performing diagnostic procedures. This assures the ice machine is not in a freeze cycle water inlet valve safety shut-off mode. You must complete the entire diagnostic procedure with-in 6 minutes of starting.

Step 2 Wait until the freeze cycle starts (approximately 45 seconds, the freeze cycle starts when the compressor energizes), and then refer to chart.

Step 2

Step 2 Checking for normal operation			
Is water flowing into the water trough?	The Water Level Light is:	The Water Inlet Valve Solenoid Coil is:	Cause
yes	off	Energized	This is Normal Operation don't change any parts
no	on or off	Energized Or De-Energized	Proceed to step 3

Step 3 Leave the ice machine run, then disconnect the water level probe from control board terminal 1F.

Important

For the test to work properly you must wait until the freeze cycle starts, prior to disconnecting the water level probe. If you restart the test you must reconnect the water level probe, restart the ice machine, (step 1) and then disconnect the water level probe after the compressor starts.

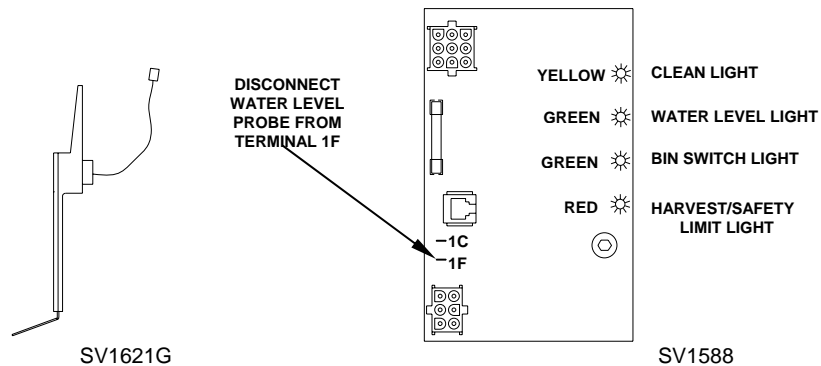

Step 3

Step 3 Disconnect water level probe from control board terminal 1F			
Is water flowing into the water trough?	The Water Level Light is:	The Water Inlet Valve Solenoid Coil is:	Cause
yes	off	Energized	The water level probe is causing the problem. Clean or replace the water level probe.
no	off	Energized	The water inlet valve is causing the problem.
no	on or off	De-Energized	The control board is causing the problem.

Diagnosing Ice Machine That Will Not Run



WARNING

High (line) voltage is applied to the control board (terminals #55 and #56) at all times. Removing control board fuse or moving the toggle switch to OFF will not remove the power supplied to the control board.

Step	Check	Notes
1	Verify primary voltage supply to ice machine.	Verify that the fuse or circuit breaker is closed.
2	Verify the high-pressure cutout is closed.	The H.P.C.O. is closed if primary power voltage is present at terminals #55 and #56 on the control board.
3	Verify control board fuse is OK.	If the bin switch light functions, the fuse is OK.
4	Verify the bin switch functions properly.	A defective bin switch can falsely indicate a full bin of ice.
5	Verify ICE/OFF/CLEAN toggle switch functions properly.	A defective toggle switch may keep the ice machine in the OFF mode.
6	Verify low DC voltage is properly grounded.	Loose DC wire connections may intermittently stop the ice machine.
7	Replace the control board.	Be sure Steps 1-6 were followed thoroughly. Intermittent problems are not usually related to the control board.

Refrigeration System

Refrigeration System

Sequence of Operation

Q1300 REFRIGERATION TUBING SCHEMATICS

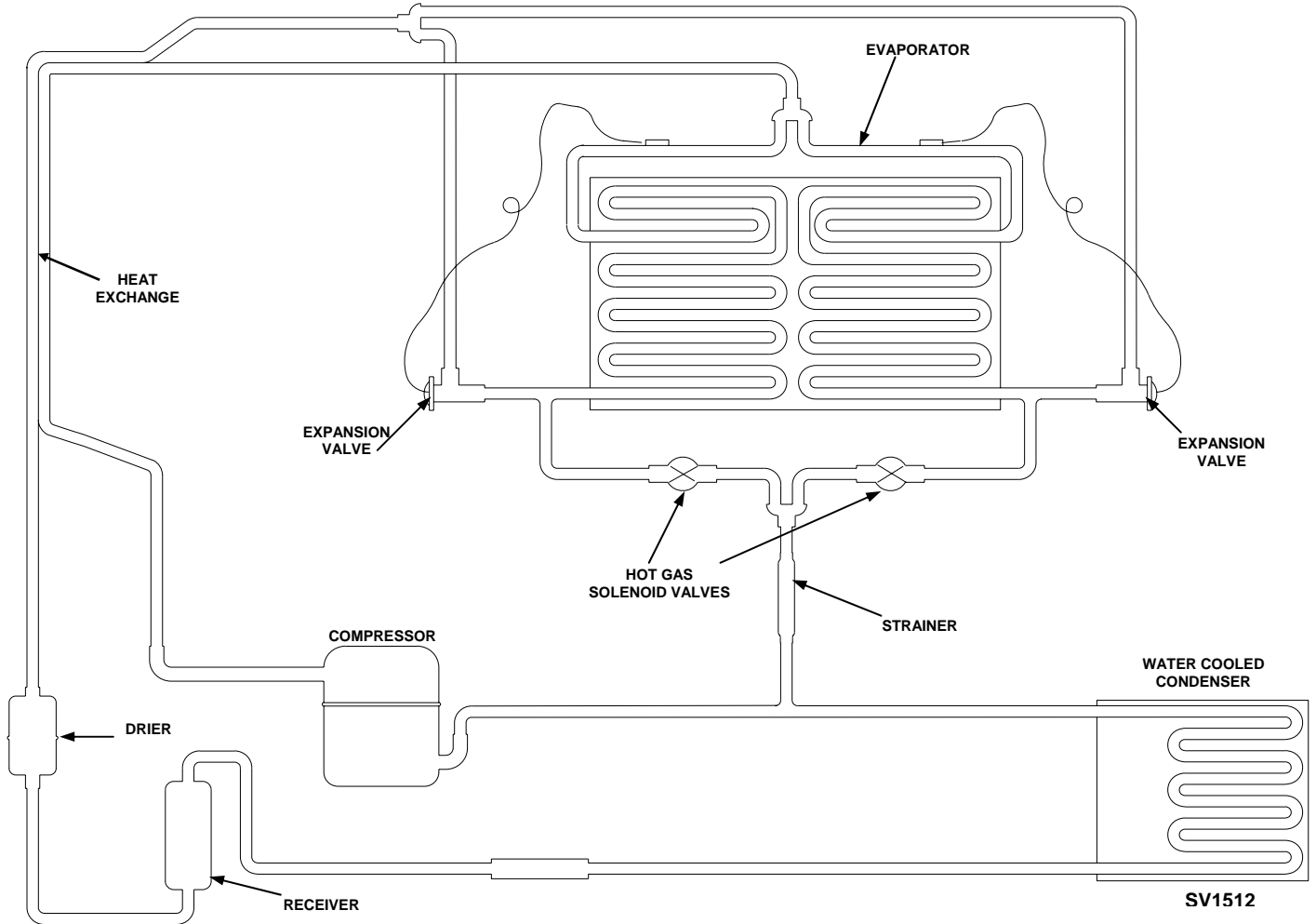

Q1300 Self-Contained Water-Cooled Models

Operational Analysis (Diagnostics)

GENERAL

When analyzing the refrigeration system, it is important to understand that different refrigeration component malfunctions may cause very similar symptoms.

Also, many external factors can make good refrigeration components appear bad. These factors can include improper installation, or water system malfunctions such as hot incoming water supply or water loss.

The following two examples illustrate how similar symptoms can result in a misdiagnosis.

1. An expansion valve bulb that is not securely fastened to the suction line and/or not insulated will cause a good expansion valve to flood. If a service technician fails to check for proper expansion valve bulb mounting, he may replace the expansion valve in error.

The ice machine now functions normally. The technician erroneously thinks that the problem was properly diagnosed and corrected by replacing the expansion valve. Actually, the problem (loose bulb) was corrected when the technician properly mounted the bulb of the replacement expansion valve.

The service technician's failure to check the expansion valve bulb for proper mounting (an external check) resulted in a misdiagnosis and the needless replacement of a good expansion valve.

3. An ice machine that is low on charge may cause a good expansion valve to starve. If a service technician fails to verify the system charge, he may replace the expansion valve in error.

During the replacement procedure, recovery, evacuation and recharging are performed correctly. The ice machine now functions normally. The technician erroneously thinks that the problem was properly diagnosed and corrected by replacing the expansion valve.

The service technician's failure to check the ice machine for a low charge condition resulted in a misdiagnosis and the needless replacement of a good expansion valve.

When analyzing the refrigeration system, use the Refrigeration System Operational Analysis Table. This table, along with detailed checklists and references, will help prevent replacing good refrigeration components due to external problems.

Refrigeration System

BEFORE BEGINNING SERVICE

Ice machines may experience operational problems only during certain times of the day or night. A machine may function properly while it is being serviced, but malfunctions later. Information provided by the user can help the technician start in the right direction, and may be a determining factor in the final diagnosis.

Ask these questions before beginning service:

- When does the ice machine malfunction? (night, day, all the time, only during the freeze cycle, etc.)
- When do you notice low ice production? (one day a week, every day, on weekends, etc.)
- Can you describe exactly what the ice machine seems to be doing?
- Has anyone been working on the ice machine?
- Is anything (such as boxes) usually stored near or on the ice machine which could obstruct airflow around the machine?
- During “store shutdown,” is the circuit breaker, water supply or air temperature altered?
- Is there any reason why incoming water pressure might rise or drop substantially?

ICE PRODUCTION CHECK

The amount of ice a machine produces directly relates to the operating water and air temperatures. This means an ice machine in a 70°F (21.2°C) room with 50°F (10.0°C) water produces more ice than the same model ice machine in a 90°F (32.2°C) room with 70°F (21.2°C) water.

1. Determine the ice machine operating conditions:
 Air Temp. Entering Condenser: _____°
 Air Temp. Around Ice Machine: _____°
 Water Temp. Entering Sump Trough: _____°

2. Refer to the appropriate 24 Hour Ice Production Chart. Use the operating conditions determined in Step 1 to find published 24 hour ice production: _____
3. Perform an actual ice production check. Use the formula below.

1.	_____	+	_____	=	_____
	Freeze Time		Harvest Time		Total Cycle Time
2.	<u>1440</u>	÷	_____	=	_____
	Minutes in 24 Hours		Total Cycle Time		Cycles Per Day
3.	_____	x	_____	=	_____
	Weight of One Harvest		Cycles Per Day		Actual 24 Hour Ice Production

Important

- Times are in minutes.
Example: 1 min., 15 sec. converts to 1.25 min. (15 seconds ÷ 60 seconds = .25 minutes)
- Weights are in pounds.
Example: 2 lb., 6 oz. converts to 2.375 lb. (6 oz. ÷ 16 oz. = .375 lb.)
- Weighing the ice is the only 100% accurate check. However, if the ice pattern is normal and the 1/8” thickness is maintained, the ice slab weights listed with the 24 Hour Ice Production Charts may be used.

4. Compare the results of Step 3 with Step 2. Ice production is normal when these numbers match closely. If they match closely, determine if:
 - Another ice machine is required.
 - More storage capacity is required.
 - Relocating the existing equipment to lower the load conditions is required.

Contact the local Manitowoc distributor for information on available options and accessories.

INSTALLATION/VISUAL INSPECTION CHECKLIST

Possible Problem	Corrective Action
Ice machine is not level	Level the ice machine
Improper clearance around top, sides and/or back of ice machine	Reinstall according to the Installation Manual
Ice machine is not on an independent electrical circuit	Reinstall according to the Installation Manual
Water filtration is plugged (if used)	Install a new water filter
Water drains are not run separately and/or are not vented	Run and vent drains according to the Installation Manual

WATER SYSTEM CHECKLIST

A water-related problem often causes the same symptoms as a refrigeration system component malfunction.

Example: A water dump valve leaking during the freeze cycle, a system low on charge, and a starving TXV have similar symptoms.

Water system problems must be identified and eliminated prior to replacing refrigeration components.

Possible Problem	Corrective Action
Water area (evaporator) is dirty	Clean as needed
Water inlet pressure not between 20 and 80 psi	Install a water regulator valve or increase the water pressure
Incoming water temperature is not between 35°F (1.7°C) and 90°F (32.2°C).	If too hot, check the hot water line check valves in other store equipment
Water filtration is plugged (if used)	Install a new water filter
Water dump valve leaking during the freeze cycle	Clean/replace dump valve as needed
Vent tube is not installed on water outlet drain	See Installation Instructions
Hoses, fittings, etc., are leaking water	Repair/replace as needed
Water fill valve is stuck open	Clean/replace as needed
Water is spraying out of the sump trough area	Stop the water spray
Uneven water flow across the evaporator	Clean the ice machine
Water is freezing behind the evaporator	Correct the water flow
Plastic extrusions and gaskets are not secured to the evaporator	Remount/replace as needed
Water does not flow over the evaporator (not trickle) immediately after the prechill	Clean/replace water level probe as needed

Refrigeration System

ICE FORMATION PATTERN

Evaporator ice formation pattern analysis is helpful in ice machine diagnostics.

Analyzing the ice formation pattern alone cannot diagnose an ice machine malfunction. However, when this analysis is used along with Manitowoc's Refrigeration System Operational Analysis Table, it can help diagnose an ice machine malfunction.

Improper ice formation can be caused by any number of problems.

Example: An ice formation that is "extremely thin on top" could be caused by a hot water supply, a dump valve leaking water, a faulty water fill valve, a low refrigerant charge, etc.

Important

Keep the water curtain in place while checking the ice formation pattern to ensure no water is lost.

1. Normal Ice Formation

Ice forms across the entire evaporator surface.

At the beginning of the freeze cycle, it may appear that more ice is forming on the bottom of the evaporator than on the top. At the end of the freeze cycle, ice formation on the top will be close to, or just a bit thinner than, ice formation on the bottom. The dimples in the cubes at the top of the evaporator may be more pronounced than those on the bottom. This is normal.

The ice thickness probe must be set to maintain the ice bridge thickness at approximately 1/8". If ice forms uniformly across the evaporator surface, but does not reach 1/8" in the proper amount of time, this is still considered normal.

2. Extremely Thin at Evaporator Outlet

There is no ice, or a considerable lack of ice formation on the top of the evaporator (tubing outlet).

Examples: No ice at all on the top of the evaporator, but ice forms on the bottom half of the evaporator. Or, the ice at the top of the evaporator reaches 1/8" to initiate a harvest, but the bottom of the evaporator already has 1/2" to 1" of ice formation.

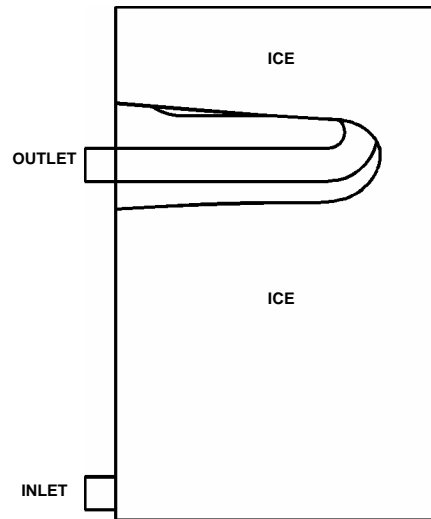

SV1576

Extremely Thin Ice Formation At Evaporator Outlet

3. Extremely Thin at Evaporator Inlet

There is no ice, or a considerable lack of ice formation on the bottom of the evaporator (tubing inlet). Examples: The ice at the top of the evaporator reaches 1/8" to initiate a harvest, but there is no ice formation at all on the bottom of the evaporator.

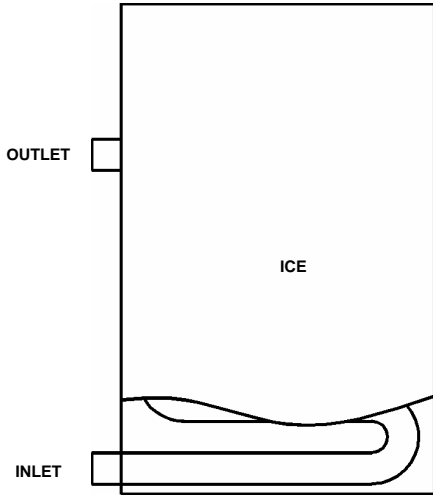

SV1575

Extremely Thin Ice Formation at Evaporator Inlet

4. Spotty Ice Formation

There are small sections on the evaporator where there is no ice formation. This could be a single corner, or a single spot in the middle of the evaporator. This is generally caused by loss of heat transfer from the tubing on the backside of the evaporator.

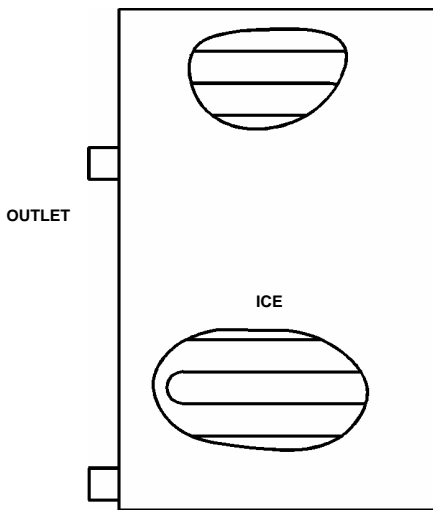

INLET

Spotty Ice Formation

SV1577

5. No Ice Formation

The ice machine operates for an extended period, but there is no ice formation at all on the evaporator.

Important

The Q1300 model machines have left and right expansion valves and separate evaporator circuits. These circuits operate independently from each other. Therefore, one may operate properly while the other is malfunctioning.

Example: If the left expansion valve is starving, it may not affect the ice formation pattern on the entire right side of the evaporator.

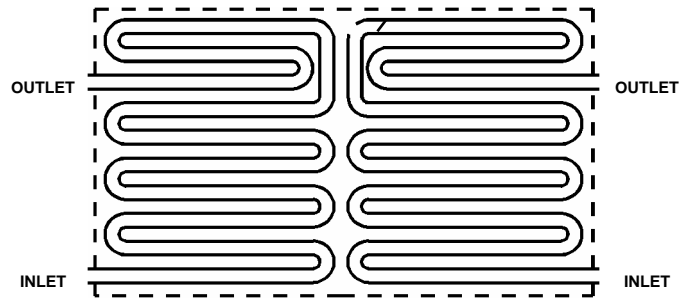

Q1800 Evaporator Tubing

SV1571

Refrigeration System

SAFETY LIMITS

General

In addition to standard safety controls, such as high pressure cut-out, the control board has two built in safety limit controls which protect the ice machine from major component failures.

Safety Limit #1: If the freeze time reaches 60 minutes, the control board automatically initiates a harvest cycle. If three consecutive 60-minute freeze cycles occur, the ice machine stops.

Safety Limit #2: If the harvest time reaches 3.5 minutes, the control board automatically returns the ice machine to the freeze cycle. If three consecutive 3.5 minute harvest cycles occur, the ice machine stops.

Determining Which Safety Limit Stopped The Ice Machine

When a safety limit condition causes the ice machine to stop, the harvest light on the control board continually flashes on and off. Use the following procedures to determine which safety limit has stopped the ice machine.

1. Move the toggle switch to OFF.
2. Move the toggle switch back to ICE.
3. Watch the harvest light. It will flash one or two times, corresponding to safety limits 1 and 2, to indicate which safety limit stopped the ice machine.

After safety limit indication, the ice machine will restart and run until a safety limit is exceeded again.

Analyzing Why Safety Limits May Stop the Ice Machine

According to the refrigeration industry, a high percentage of compressors fail as a result of external causes. These can include: flooding or starving expansion valves, dirty condensers, water loss to the ice machine, etc. The safety limits protect the ice machine (primarily the compressor) from external failures by stopping ice machine operation before major component damage occurs.

The safety limit system is similar to a high pressure cut-out control. It stops the ice machine, but does not tell what is wrong. The service technician must analyze the system to determine what caused the high pressure cut-out, or a particular safety limit, to stop the ice machine.

The safety limits are designed to stop the ice machine prior to major component failures, most often a minor problem or something external to the ice machine. This may be difficult to diagnose, as many external problems occur intermittently.

Example: An ice machine stops intermittently on safety limit #1 (long freeze times). The problem could be a low ambient temperature at night, a water pressure drop, the water is turned off one night a week, etc.

When a high pressure cut-out or a safety limit stops the ice machine, they are doing what they are supposed to do. That is, stopping the ice machine before a major component failure occurs.

Refrigeration and electrical component failures may also trip a safety limit. Eliminate all electrical components and external causes first. If it appears that the refrigeration system is causing the problem, use Manitowoc's Refrigeration System Operational Analysis Table, along with detailed charts, checklists, and other references to determine the cause.

The following checklists are designed to assist the service technician in analysis. However, because there are many possible external problems, do not limit your diagnosis to only the items listed.

Safety Limit #1

Freeze time exceeds 60 minutes for 3 consecutive freeze cycles.

Possible Cause	Check/Correct
Improper installation	<ul style="list-style-type: none"> • See "Installation/Visual Inspection Checklist" on page 7-10
Water system	<ul style="list-style-type: none"> • Low water pressure (20 psi min.) • High water pressure (80 psi max.) • High water temperature (90°F/32.2°C max.) • Clogged water distribution tube • Dirty/defective water fill valve • Dirty/defective water dump valve • Defective water pump
Electrical system	<ul style="list-style-type: none"> • Ice thickness probe out of adjustment • Harvest cycle not initiated electrically • Contactor not energizing • Compressor electrically non-operational
Restricted condenser water flow (water-cooled models)	<ul style="list-style-type: none"> • Low water pressure (20 psi min.) • High water temperature (90°F/32.2°C max.) • Dirty condenser • Dirty/defective water regulating valve • Water regulating valve out of adjustment
Refrigeration system	<ul style="list-style-type: none"> • Non-Manitowoc components • Improper refrigerant charge • Defective hot gas valve • Defective compressor • TXV starving or flooding (check bulb mounting) • Non-condensables in refrigeration system • Plugged or restricted high side refrigerant lines or component

SAFETY LIMIT NOTES

- Because there are many possible external problems, do not limit your diagnosis to only the items listed in this chart.
- A continuous run of 100 harvests automatically erases the safety limit code.
- The control board will store and indicate only one safety limit – the last one exceeded.
- If the toggle switch is moved to the OFF position and then back to the ICE position prior to reaching the 100-harvest point, the last safety limit exceeded will be indicated.
- If the harvest light did not flash prior to the ice machine restarting, then the ice machine did not stop because it exceeded a safety limit.

Refrigeration System

Safety Limit #2

Harvest time exceeds 3.5 minutes for 3 consecutive harvest cycles.

Possible Cause	Check/Correct
Improper installation	<ul style="list-style-type: none"> See "Installation/Visual Inspection Checklist" on page 7-10
Water system	<ul style="list-style-type: none"> Water area (evaporator) dirty Dirty/defective water dump valve Vent tube not installed on water outlet drain Water freezing behind evaporator Plastic extrusions and gaskets not securely mounted to the evaporator Low water pressure (20 psi min.) Loss of water from sump area Clogged water distribution tube Dirty/defective water fill valve Defective water pump
Electrical system	<ul style="list-style-type: none"> Ice thickness probe out of adjustment Ice thickness probe dirty Bin switch defective Premature harvest
Refrigeration system	<ul style="list-style-type: none"> Non-Manitowoc components Water regulating valve dirty/defective Improper refrigerant charge Defective hot gas valve TXV flooding (check bulb mounting)

SAFETY LIMIT NOTES

- Because there are many possible external problems, do not limit your diagnosis to only the items listed in this chart.
- A continuous run of 100 harvests automatically erases the safety limit code.
- The control board will store and indicate only one safety limit – the last one exceeded.
- If the toggle switch is moved to the OFF position and then back to the ICE position prior to reaching the 100-harvest point, the last safety limit exceeded will be indicated.
- If the harvest light did not flash prior to the ice machine restarting, then the ice machine did not stop because it exceeded a safety limit.

HOT GAS VALVE TEMPERATURE CHECK

General

A hot gas valve requires a critical orifice size. This meters the amount of hot gas flowing into the evaporator during the harvest cycle. If the orifice is even slightly too large or too small, long harvest cycles will result.

A too-large orifice causes refrigerant to condense to liquid in the evaporator during the harvest cycle. This liquid will cause compressor damage. A too-small orifice does not allow enough hot gas into the evaporator. This causes low suction pressure, and insufficient heat for a harvest cycle.

Normally, a defective hot gas valve can be rebuilt. Refer to the Parts Manual for proper valve application and rebuild kits. If replacement is necessary, Use only “original” Manitowoc replacement parts.

Hot Gas Valve Analysis

Symptoms of a hot gas valve remaining partially open during the freeze cycle can be similar to symptoms of either an expansion valve or compressor problem. The best way to diagnose a hot gas valve is by using Manitowoc’s Ice Machine Refrigeration System Operational Analysis Table.

Use the following procedure and table to help determine if a hot gas valve is remaining partially open during the freeze cycle.

1. Wait five minutes into the freeze cycle.
2. Feel the inlet of the hot gas valve(s).

3. Feel the compressor discharge line.

 **WARNING**

The inlet of the hot gas valve and the compressor discharge line could be hot enough to burn your hand. Just touch them momentarily.

4. Compare the temperature of the inlet of the hot gas valves to the temperature of the compressor discharge line.

Findings	Comments
The inlet of the hot gas valve is cool enough to touch and the compressor discharge line is hot.	This is normal as the discharge line should always be too hot to touch and the hot gas valve inlet, although too hot to touch during harvest, should be cool enough to touch after 5 minutes into the freeze cycle.
The inlet of the hot gas valve is hot and approaches the temperature of a hot compressor discharge line.	This is an indication something is wrong, as the hot gas valve inlet did not cool down during the freeze cycle. If the compressor dome is also entirely hot, the problem is not a hot gas valve leaking, but rather something causing the compressor (and the entire ice machine) to get hot.
Both the inlet of the hot gas valve and the compressor discharge line are cool enough to touch.	This is an indication something is wrong, causing the compressor discharge line to be cool to the touch. This is not caused by a hot gas valve leaking.

Important

Feeling the hot gas valve outlet or across the hot gas valve itself will not work for this comparison.

The hot gas valve outlet is on the suction side (cool refrigerant). It may be cool enough to touch even if the valve is leaking.

Refrigeration System

ANALYZING DISCHARGE PRESSURE DURING FREEZE OR HARVEST CYCLE

1. Determine the ice machine operating conditions:
- Air temp. entering condenser _____
- Air temp. around ice machine _____
- Water temp. entering sump trough _____

2. Refer to Operating Pressure Chart for ice machine being checked.

Use the operating conditions determined in Step 1 to find the published normal discharge pressures.

Freeze Cycle _____ Harvest Cycle _____

3. Perform an actual discharge pressure check.

	Freeze Cycle PSIG	Harvest Cycle PSIG
Beginning of Cycle	_____	_____
Middle of Cycle	_____	_____
End of Cycle	_____	_____

4. Compare the actual discharge pressure (Step 3) with the published discharge pressure (Step 2).

The discharge pressure is normal when the actual pressure falls within the published pressure range for the ice machine's operating conditions.

Freeze Cycle Discharge Pressure High Checklist

Possible Cause	Check/Correct
Improper installation	<ul style="list-style-type: none"> See "Installation/Visual Inspection Checklist" on page 7-10
Restricted condenser water flow (water-cooled models)	<ul style="list-style-type: none"> Low water pressure (20 psi min.) High inlet water temperature (90°F/32.2°C max.) Dirty condenser Dirty/defective water regulating valve Water regulating valve out of adjustment
Improper refrigerant charge	<ul style="list-style-type: none"> Overcharged Non-condensibles in system Wrong type of refrigerant
Other	<ul style="list-style-type: none"> Non-Manitowoc components in system High side refrigerant lines/component restricted (before mid-condenser)

Freeze Cycle Discharge Pressure Low Checklist

Possible Cause	Check/Correct
Improper installation	<ul style="list-style-type: none"> See "Installation/Visual Inspection Checklist" on page 7-10
Improper refrigerant charge	<ul style="list-style-type: none"> Undercharged Wrong type of refrigerant
Water regulating valve (water-cooled condensers)	<ul style="list-style-type: none"> Out of adjustment Defective
Other	<ul style="list-style-type: none"> Non-Manitowoc components in system

NOTE: Do not limit your diagnosis to only the items listed in the checklists.

ANALYZING SUCTION PRESSURE DURING FREEZE CYCLE

The suction pressure gradually drops throughout the freeze cycle. The actual suction pressure (and drop rate) changes as the air and water temperatures entering the ice machine change. This affects freeze cycle times.

To analyze and identify the proper suction pressure drop throughout the freeze cycle, compare the published suction pressure to the published freeze cycle time. “Operating Pressure” and “Freeze Cycle Time” charts can be found later in this section.

NOTE: Analyze discharge pressure before analyzing suction pressure. High or low discharge pressure may be causing high or low suction pressure.

Procedure

Step	Example Using QR1801WM Model Ice Machine			
1. Determine the ice machine operating conditions.	Air temp. around ice machine:		<u>80°F/26.7°C</u>	
	Water temp. entering water fill valve:		<u>70°F/21.1°C</u>	
2A. Refer to “Cycle Time” and “Operating Pressure” charts for ice machine model being checked. Using operating conditions from Step 1, determine published freeze cycle time and published freeze cycle suction pressure.	Published freeze cycle time: <u>9.8-11.0</u> minutes		Published freeze cycle suction pressure: <u>40-20</u> PSIG	
2B. Compare the published freeze cycle time and published freeze cycle suction pressure. Develop a chart.	<div style="text-align: center;"> <p>Published Freeze Cycle Time (minutes)</p> <p>Published Freeze Cycle Suction Pressure (psig)</p> </div>			
3. Perform an actual suction pressure check at the beginning, middle and end of the freeze cycle. Note the times at which the readings are taken.	Beginning of freeze cycle:		<u>59</u> PSIG at <u>1</u> minute	
	Middle of freeze cycle:		<u>48</u> PSIG at <u>5</u> minutes	
	End of freeze cycle:		<u>40</u> PSIG at <u>11</u> minutes	
4. Compare the actual freeze cycle suction pressure (Step 3) to the published freeze cycle time and pressure comparison (Step 2B). Determine if the suction pressure is high, low or acceptable.	<u>Time Into Freeze Cycle</u>	<u>Published Pressure</u>	<u>Actual Pressure</u>	<u>Result</u>
	1 minutes	40 PSIG	59 PSIG	High
	5 minutes	30 PSIG	48 PSIG	High
	11 minutes	20 PSIG	40 PSIG	High

Refrigeration System

Freeze Cycle Suction Pressure High Checklist

Possible Cause	Check/Correct
Improper installation	<ul style="list-style-type: none">• See "Installation/Visual Inspection Checklist"
Discharge pressure	<ul style="list-style-type: none">• Discharge pressure is too high, and is affecting low side (See "Freeze Cycle Discharge Pressure High Checklist")
Improper refrigerant charge	<ul style="list-style-type: none">• Overcharged• Wrong type of refrigerant
Other	<ul style="list-style-type: none">• Non-Manitowoc components in system• Hot gas valve stuck open• TXV flooding (check bulb mounting)• Defective compressor

Freeze Cycle Suction Pressure Low Checklist

Possible Cause	Check/Correct
Improper installation	<ul style="list-style-type: none">• See "Installation/Visual Inspection Checklist"
Discharge pressure	<ul style="list-style-type: none">• Discharge pressure is too low, and is affecting low side (See "Freeze Cycle Discharge Pressure Low Checklist")
Improper refrigerant charge	<ul style="list-style-type: none">• Undercharged• Wrong type of refrigerant
Other	<ul style="list-style-type: none">• Non-Manitowoc components in system• Improper water supply over evaporator (See "Water System Checklist")• Loss of heat transfer from tubing on back side of evaporator• Restricted/plugged liquid line drier• Restricted/plugged tubing in suction side of refrigeration system• TXV starving

NOTE: Do not limit your diagnosis to only the items listed in the checklists.

HOW TO USE THE REFRIGERATION SYSTEM OPERATIONAL ANALYSIS TABLES

General

These tables must be used with charts, checklists and other references to eliminate refrigeration components not listed on the tables and external items and problems which can cause good refrigeration components to appear defective.

The tables list five different defects that may affect the ice machine's operation.

NOTE: A low-on-charge ice machine and a starving expansion valve have very similar characteristics and are listed under the same column.

NOTE: Before starting, see "Before Beginning Service" for a few questions to ask when talking to the ice machine owner.

Procedure

Step 1 Complete the "Operation Analysis" column.

Read down the left "Operational Analysis" column. Perform all procedures and check all information listed. Each item in this column has supporting reference material to help analyze each step.

While analyzing each item separately, you may find an "external problem" causing a good refrigerant component to appear bad. Correct problems as they are found. If the operational problem is found, it is not necessary to complete the remaining procedures.

Step 2 Enter check marks in the small boxes.

Each time the actual findings of an item in the "Operational Analysis" column matches the published findings on the table, enter a check mark.

Example: Freeze cycle suction pressure is determined to be low. Enter a check mark in the "low" box.

Step 3 Add the check marks listed under each of the four columns. Note the column number with the highest total and proceed to "Final Analysis."

NOTE: If two columns have matching high numbers, a procedure was not performed properly and/or supporting material was not analyzed correctly.

Final Analysis

The column with the highest number of check marks identifies the refrigeration problem.

COLUMN 1 - HOT GAS VALVE LEAKING

Normally, a leaking hot gas valve can be repaired with a rebuild kit instead of changing the entire valve. Rebuild or replace the valve as required.

COLUMN 2 - LOW CHARGE/TXV STARVING

Normally, a starving expansion valve only affects the freeze cycle pressures, not the harvest cycle pressures. A low refrigerant charge normally affects both pressures. Verify the ice machine is not low on charge before replacing an expansion valve.

1. Add refrigerant charge in 2 to 4 oz. increments as a diagnostic procedure to verify a low charge. If the problem is corrected, the ice machine is low on charge. Find the refrigerant leak. The ice machine must operate with the nameplate charge. If the leak cannot be found, proper refrigerant procedures must still be followed. Change the liquid line drier. Then, evacuate and weigh in the proper charge.
2. If the problem is not corrected by adding charge, the expansion valve is faulty. On dual expansion valve ice machines, change only the TXV that is starving. If both TXV's are starving, they are probably good, and are being affected by some other malfunction, such as low charge.

COLUMN 3 - TXV FLOODING

A loose or improperly mounted expansion valve bulb causes the expansion valve to flood. Check bulb mounting, insulation, etc., before changing the valve. On dual expansion valve machines, the service technician should be able to tell which TXV is flooding by analyzing ice formation patterns. Change only the flooding expansion valve.

COLUMN 4 - COMPRESSOR

Replace the compressor and start components. To receive warranty credit, the compressor ports must be properly sealed by crimping and soldering them closed. Old start components must be returned with the faulty compressor.

Refrigeration System



Q Model Dual Expansion Valve Refrigeration System Operational Analysis Table

This table must be used with charts, checklists and other references to eliminate refrigeration components not listed on the table and external items and problems which can cause good refrigeration components to appear defective.

Operational Analysis (listed below)	1	2	3	4
Ice Production	Published 24 hour ice production _____ Calculated (actual) ice production _____ NOTE: The ice machine is operating properly if the ice production and ice formation pattern is normal			
Safety limits Refer to "Analyzing Safety Limits" to eliminate problems and/or components not listed on this table	Stops on safety limit: 1 <input type="checkbox"/>	Stops on safety limit: 1 <input type="checkbox"/>	Stops on safety limit: 1 or 2 <input type="checkbox"/>	Stops on safety limit: 1 <input type="checkbox"/>
Ice Formation Pattern Left side _____ Right side _____	Ice formation is extremely thin on top of one side of evaporator -or- No ice formation on one side of evaporator <input type="checkbox"/>	Ice formation is extremely thin on top of one or both sides of evaporator -or- No ice formation on entire evaporator <input type="checkbox"/>	Ice formation normal -or- Ice formation is extremely thin on bottom of one side of evaporator -or- No ice formation on entire evaporator <input type="checkbox"/>	Ice formation normal -or- No ice formation on entire evaporator <input type="checkbox"/>
Wait 5 minutes into the freeze cycle. Compare temperatures of compressor discharge line and both hot gas valve inlets . Comp. Disc. _____ °F Left gas inlet _____ °F Right gas inlet _____ °F	One hot gas valve inlet is Hot -and- approaches the temperature of a Hot compressor discharge line. <input type="checkbox"/>	Both hot gas valve inlets are cool enough to hold hand on -and- the compressor discharge line is Hot . <input type="checkbox"/>	Both hot gas valve inlets are cool enough to hold hand on -and- the compressor discharge line is cool enough to hold hand on. <input type="checkbox"/>	Both hot gas valve inlets are cool enough to hold hand on -and- the compressor discharge line is Hot . <input type="checkbox"/>
Freeze cycle DISCHARGE pressure _____ 1 minute _____ Middle _____ End into cycle	If discharge pressure is High or Low refer to a freeze cycle high or low discharge pressure problem checklist to eliminate problems and/or components not listed on this table before proceeding.			
Freeze cycle SUCTION pressure Beginning _____ Middle _____ End	If suction pressure is High or Low refer to a freeze cycle high or low suction pressure problem checklist to eliminate problems and/or components not listed on this table before proceeding.			
Miscellaneous Enter items in proper boxes.	<input type="checkbox"/>	<input type="checkbox"/>	<input type="checkbox"/>	<input type="checkbox"/>
Final Analysis Enter total number of boxes checked in each column.	Hot gas valve leaking	Low on charge -or- TXV Starving	TXV Flooding	Compressor

MANITOWOC ICE, INC.

2110 South 26th Street P.O. Box 1720 Manitowoc, WI 54221-1720
Phone: (920) 682-0161 Service Fax: (920) 683-7585 Web Site - www.manitowocice.com

Pressure Control Specifications and Diagnostics

HIGH PRESSURE CUTOUT

(HPCO) CONTROL

Function

Stops the ice machine if subjected to excessive high-side pressure.

The HPCO control is normally closed, and opens on a rise in discharge pressure.

Specifications

Cut-out: 450 psig \pm 10

Cut-in: Manual or automatic reset

(Must be below 300 psig to reset).

Check Procedure

1. Set ICE/OFF/CLEAN switch to OFF, (Manual reset HPCO reset if tripped).
2. Connect manifold gauges.
3. Hook voltmeter in parallel across the HPCO, leaving wires attached.
4. On water-cooled models, close the water service valve to the water condenser inlet. On self-contained air-cooled and remote models, disconnect the fan motor.
5. Set ICE/OFF/CLEAN switch to ICE.
6. No water or air flowing through the condenser will cause the HPCO control to open because of excessive pressure. Watch the pressure gauge and record the cut-out pressure.

WARNING

If discharge pressure exceeds 460 psig and the HPCO control does not cut out, set ICE/OFF/CLEAN switch to OFF to stop ice machine operation.

Replace the HPCO control if it:

- Will not reset (below 300 psig)
- Does not open at the specified cut-out point

Refrigeration System

Cycle Time/24 Hour Ice Production/Refrigerant Pressure Charts Q1300 SERIES WATER-COOLED

NOTE: These characteristics may vary depending on operating conditions.

Cycle Times

Freeze Time + Harvest Time = Cycle Time

Air Temp. Around Ice Machine °F/°C	Freeze Time			Harvest Time
	Water Temperature °F/°C			
	50/10.0	70/21.1	90/32.2	
70/21.1	9.0-10.1	9.8-10.9	11.4-12.6	1-2.5
80/26.7	9.1-10.1	9.8-11.0	11.6-12.9	
90/32.2	9.2-10.3	10.0-11.2	12.0-13.3	
100/37.8	9.4-10.5	10.1-11.3	12.2-13.6	

¹Times in minutes

24 Hour Ice Production

Air Temp. Around Ice Machine °F/°C	Water Temperature °F/°C		
	50/10.0	70/21.1	90/32.2
70/21.1	1370	1280	1120
80/26.7	1360	1270	1100
90/32.2	1340	1250	1070
100/37.8	1320	1240	1050

¹Based on average ice slab weight of 10.0 - 11.0 lb.

²Regular cube derate is 7%

Condenser Water Consumption	90/32.2 Air Temperature Around Ice Machine Water Temperature °F/°C		
	50/10.0	70/21.1	90/32.2
Gal/24 hours	1150	2220	7400

¹Water regulating valve set to maintain 240 PSIG discharge pressure

Operating Pressures

Air Temp. Around Ice Machine °F/°C	Freeze Cycle		Harvest Cycle	
	Discharge Pressure PSIG	Suction Pressure PSIG	Discharge Pressure PSIG	Suction Pressure PSIG
50/10.0	235-245	40-18	150-180	70-80
70/21.1	235-245	40-18	150-180	70-80
80/26.7	235-245	40-20	150-180	70-80
90/32.2	235-250	42-20	150-180	70-80
100/37.8	235-255	44-20	150-180	70-80
110/43.3	240-265	46-20	150-180	70-80

¹Suction pressure drops gradually throughout the freeze cycle

Refrigerant Recovery/Evacuation and Recharging

NORMAL SELF-CONTAINED MODEL PROCEDURES

Refrigerant Recovery/Evacuation

Do not purge refrigerant to the atmosphere. Capture refrigerant using recovery equipment. Follow the manufacturer's recommendations.

Important

Manitowoc Ice, Inc. assumes no responsibility for the use of contaminated refrigerant. Damage resulting from the use of contaminated refrigerant is the sole responsibility of the servicing company.

Important

Replace the liquid line drier before evacuating and recharging. Use only a Manitowoc (O.E.M.) liquid line filter drier to prevent voiding the warranty.

CONNECTIONS

1. Suction side of the compressor through the suction service valve.
2. Discharge side of the compressor through the discharge service valve.

SELF-CONTAINED RECOVERY/EVACUATION

1. Place the toggle switch in the OFF position.
2. Install manifold gauges, charging cylinder/scale, and recovery unit or two-stage vacuum pump.

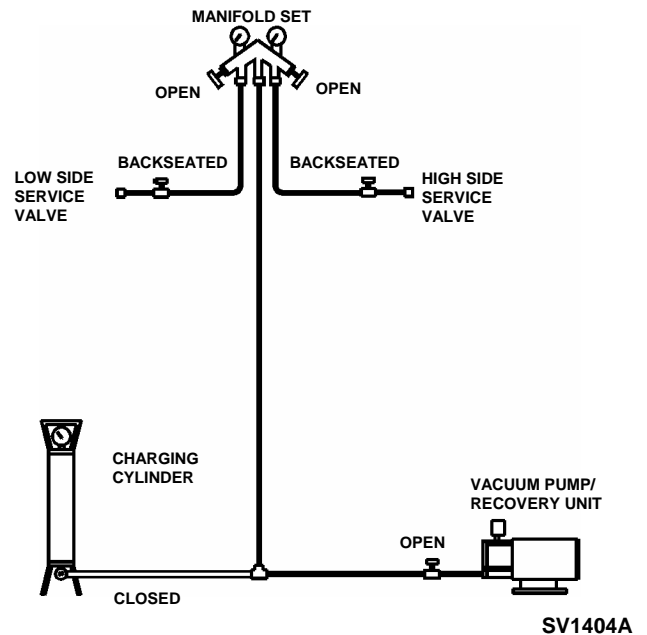

Recovery/Evacuation Connections

3. Open (backseat) the high and low side ice machine service valves, and open high and low side on manifold gauges.
4. Perform recovery or evacuation:
 - A. Recovery: Operate the recovery unit as directed by the manufacturer's instructions.
 - B. Evacuation prior to recharging: Pull the system down to 250 microns. Then, allow the pump to run for an additional half hour. Turn off the pump and perform a standing vacuum leak check.

NOTE: Check for leaks using a halide or electronic leak detector after charging the ice machine.

5. Follow the Charging Procedures on the next page.

Refrigeration System

Self-Contained Charging Procedures

Important

The charge is critical on all Manitowoc ice machines. Use a scale or a charging cylinder to ensure the proper charge is installed.

1. Be sure the toggle switch is in the OFF position.

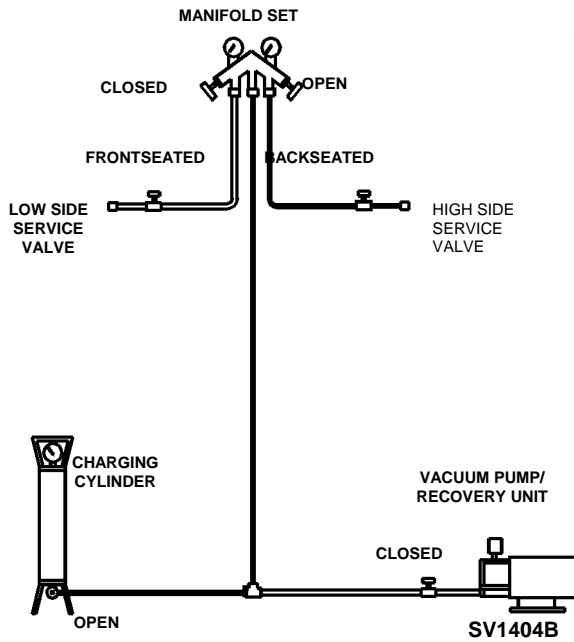

Charging Connections

2. Close the vacuum pump valve, the low side service valve, and the low side manifold gauge valve.
3. Open the high side manifold gauge valve, and backseat the high side service valve.
4. Open the charging cylinder and add the proper refrigerant charge (shown on nameplate) through the discharge service valve.
5. Let the system “settle” for 2 to 3 minutes.
6. Place the toggle switch in the ICE position.
7. Close the high side on the manifold gauge set. Add any remaining vapor charge through the suction service valve (if necessary).

NOTE: Manifold gauges must be removed properly to ensure that no refrigerant contamination or loss occurs.

8. Make sure that all of the vapor in the charging hoses is drawn into the ice machine before disconnecting the charging hoses.
 - A. Run the ice machine in freeze cycle.
 - B. Close the high side service valve at the ice machine.
 - C. Open the low side service valve at the ice machine.
 - D. Open the high and low side valves on the manifold gauge set. Any refrigerant in the lines will be pulled into the low side of the system.
 - E. Allow the pressures to equalize while the ice machine is in the freeze cycle.
 - F. Close the low side service valve at the ice machine.

Remove the hoses from the ice machine and install the caps.

SYSTEM CONTAMINATION CLEANUP

General

This section describes the basic requirements for restoring contaminated systems to reliable service.

Important

Manitowoc Ice, Inc. assumes no responsibility for the use of contaminated refrigerant. Damage resulting from the use of contaminated refrigerant is the sole responsibility of the servicing company.

Determining Severity Of Contamination

System contamination is generally caused by either moisture or residue from compressor burnout entering the refrigeration system.

Inspection of the refrigerant usually provides the first indication of system contamination. Obvious moisture or an acrid odor in the refrigerant indicates contamination.

If either condition is found, or if contamination is suspected, use a Total Test Kit from Totaline or a similar diagnostic tool. These devices sample refrigerant, eliminating the need to take an oil sample. Follow the manufacturer's directions.

If a refrigerant test kit indicates harmful levels of contamination, or if a test kit is not available, inspect the compressor oil.

1. Remove the refrigerant charge from the ice machine.
2. Remove the compressor from the system.
3. Check the odor and appearance of the oil.
4. Inspect open suction and discharge lines at the compressor for burnout deposits.
5. If no signs of contamination are present, perform an acid oil test.

Check the chart below to determine the type of cleanup required.

Contamination/Cleanup Chart	
Symptoms/Findings	Required Cleanup Procedure
No symptoms or suspicion of contamination	Normal evacuation/recharging procedure
Moisture/Air Contamination symptoms <ul style="list-style-type: none"> • Refrigeration system open to atmosphere for longer than 15 minutes • Refrigeration test kit and/or acid oil test shows contamination • Leak in water-cooled condenser • No burnout deposits in open compressor lines 	Mild contamination cleanup procedure
Mild Compressor Burnout symptoms <ul style="list-style-type: none"> • Oil appears clean but smells acrid • Refrigeration test kit or acid oil test shows harmful acid content • No burnout deposits in open compressor lines 	Mild contamination cleanup procedure
Severe Compressor Burnout symptoms <ul style="list-style-type: none"> • Oil is discolored, acidic, and smells acrid • Burnout deposits found in the compressor and lines, and in other components 	Severe contamination cleanup procedure

Refrigeration System

Mild System Contamination Cleanup

Procedure

1. Replace any failed components.
2. If the compressor is good, change the oil.
3. Replace the liquid line drier.

NOTE: If the contamination is from moisture, use heat lamps during evacuation. Position them at the compressor, condenser and evaporator prior to evacuation. Do not position heat lamps too close to plastic components, or they may melt or warp.

Important

Dry nitrogen is recommended for this procedure. This will prevent CFC release.

4. Follow the normal evacuation procedure, except replace the evacuation step with the following:
 - A. Pull vacuum to 1000 microns. Break the vacuum with dry nitrogen and sweep the system. Pressurize to a minimum of 5 psi.
 - B. Pull vacuum to 500 microns. Break the vacuum with dry nitrogen and sweep the system. Pressurize to a minimum of 5 psi.
 - C. Change the vacuum pump oil.
 - D. Pull vacuum to 250 microns. Run the vacuum pump for 1/2 hour on self-contained models, 1 hour on remotes.

NOTE: You may perform a standing vacuum test to make a preliminary leak check. You should use an electronic leak detector after system charging to be sure there is no leak.

5. Charge the system with the proper refrigerant to the nameplate charge.
6. Operate the ice machine.

Severe System Contamination Cleanup

Procedure

1. Remove the refrigerant charge.
2. Remove the compressor.
3. Disassemble the hot gas solenoid valve. If burnout deposits are found inside the valve, install a rebuild kit, and replace manifold strainer, and TXV valves.
4. Wipe away any burnout deposits from suction and discharge lines at compressor.
5. Sweep through the open system with dry nitrogen.

Important

Refrigerant sweeps are not recommended, as they release CFC's into the atmosphere.

7. Install a new compressor and new start components.
8. Install a suction line filter-drier with acid and moisture removal capability (P/N 89-3028-3). Place the filter drier as close to the compressor as possible.
9. Install an access valve at the inlet of the suction line drier.
10. Install a new liquid line drier.

Continued on next page

11. Follow the normal evacuation procedure, except replace the evacuation step with the following:

Important

Dry nitrogen is recommended for this procedure. This will prevent CFC release.

- A. Pull vacuum to 1000 microns. Break the vacuum with dry nitrogen and sweep the system. Pressurize to a minimum of 5 psi.
- B. Change the vacuum pump oil.
- C. Pull vacuum to 500 microns. Break the vacuum with dry nitrogen and sweep the system. Pressurize to a minimum of 5 psi.
- D. Change the vacuum pump oil.
- E. Pull vacuum to 250 microns. Run the vacuum pump for 1/2 hour on self-contained models, 1 hour on remotes.

NOTE: You may perform a standing vacuum test to make a preliminary leak check. You should use an electronic leak detector after system charging to be sure there is no leak.

12. Charge the system with the proper refrigerant to the nameplate charge.
13. Operate the ice machine for one hour. Then, check the pressure drop across the suction line filter-drier.
 - A. If the pressure drop is less than 1 psi, the filter-drier should be adequate for complete cleanup.
 - B. If the pressure drop exceeds 1 psi, change the suction line filter-drier and the liquid line drier. Repeat until the pressure drop is acceptable.
14. Operate the ice machine for 48-72 hours. Then, remove the suction line drier and change the liquid line drier.
15. Follow normal evacuation procedures.

REPLACING PRESSURE CONTROLS WITHOUT REMOVING REFRIGERANT CHARGE

This procedure reduces repair time and cost. Use it when any of the following components require replacement, and the refrigeration system is operational and leak-free.

- Water regulating valve (water-cooled only)
- High pressure cut-out control
- High side service valve
- Low side service valve

Important

This is a required in-warranty repair procedure.

1. Disconnect power to the ice machine.
2. Follow all manufacturer's instructions supplied with the pinch-off tool. Position the pinch-off tool around the tubing as far from the pressure control as feasible. (See the figure on next page.) Clamp down on the tubing until the pinch-off is complete.

 **WARNING**

Do not unsolder a defective component. Cut it out of the system. Do not remove the pinch-off tool until the new component is securely in place.

3. Cut the tubing of the defective component with a small tubing cutter.
4. Solder the replacement component in place. Allow the solder joint to cool.
5. Remove the pinch-off tool.
6. Re-round the tubing. Position the flattened tubing in the proper hole in the pinch off tool. Tighten the wingnuts until the block is tight and the tubing is rounded. (See the drawing on next page.)

NOTE: The pressure controls will operate normally once the tubing is re-rounded. Tubing may not re-round 100%..

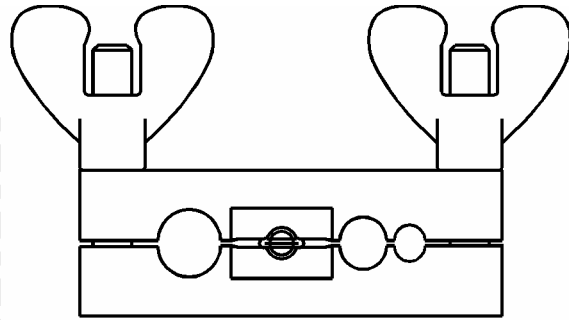
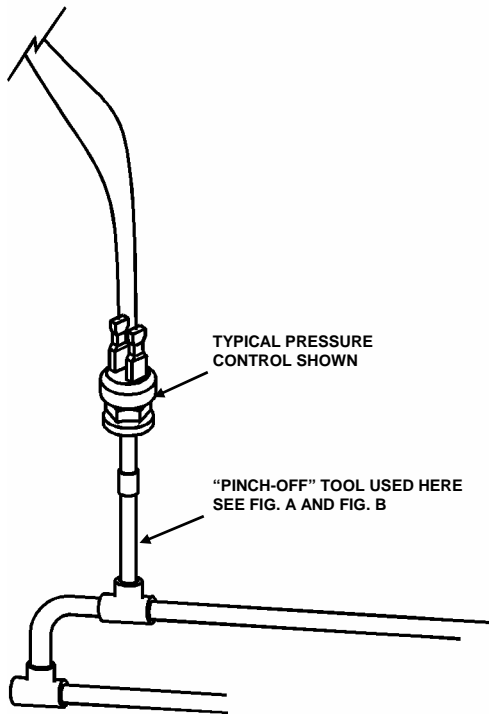

FIG. A - "PINCHING OFF" TUBING

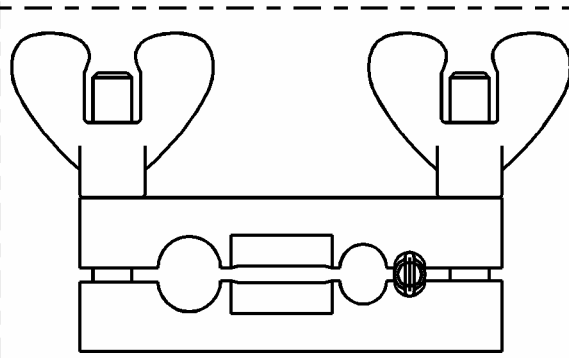

FIG. B - RE-ROUNDING TUBING

SV1406

Using Pinch-Off Tool

FILTER-DRIERS

The filter-driers used on Manitowoc ice machines are manufactured to Manitowoc specifications.

The difference between Manitowoc driers and off-the-shelf driers is in filtration. Manitowoc driers have dirt-retaining filtration, with fiberglass filters on both the inlet and outlet ends. This is very important because ice machines have a back-flushing action which takes place during every harvest cycle.

These filter-driers have a very high moisture removal capability and a good acid removal capacity.

The size of the filter-drier is important. The refrigerant charge is critical. Using an improperly sized filter-drier will cause the ice machine to be improperly charged with refrigerant.

Important

Driers are covered as a warranty part. The drier must be replaced any time the system is opened for repairs.

TOTAL SYSTEM REFRIGERANT CHARGES

Important

Refer to the ice machine serial number tag to verify the system charge.

Series	Version	Charge
Q1800	Water-Cooled	44 oz.

NOTE: Charged using R-404A refrigerant.

Refrigeration System

REFRIGERANT DEFINITIONS

Recover

To remove refrigerant, in any condition, from a system and store it in an external container, without necessarily testing or processing it in any way.

Recycle

To clean refrigerant for re-use by oil separation and single or multiple passes through devices, such as replaceable core filter-driers, which reduce moisture, acidity and particulate matter. This term usually applies to procedures implemented at the field job site or at a local service shop.

Reclaim

To reprocess refrigerant to new product specifications (see below) by means which may include distillation. A chemical analysis of the refrigerant is required after processing to be sure that product specifications are met. This term usually implies the use of processes and procedures available only at a reprocessing or manufacturing facility.

Chemical analysis is the key requirement in this definition. Regardless of the purity levels reached by a reprocessing method, refrigerant is not considered “reclaimed” unless it has been chemically analyzed and meets ARI Standard 700 (latest edition).

New Product Specifications

This means ARI Standard 700 (latest edition). Chemical analysis is required to assure that this standard is met.

REFRIGERANT RE-USE POLICY

Manitowoc recognizes and supports the need for proper handling, re-use, and disposal of, CFC and HCFC refrigerants. Manitowoc service procedures require recapturing refrigerants, not venting them to the atmosphere.

It is not necessary, in or out of warranty, to reduce or compromise the quality and reliability of your customers' products to achieve this.

Important

Manitowoc Ice, Inc. assumes no responsibility for use of contaminated refrigerant. Damage resulting from the use of contaminated, recovered, or recycled refrigerant is the sole responsibility of the servicing company.

Manitowoc approves the use of:

1. New Refrigerant

- Must be of original nameplate type.

2. Reclaimed Refrigerant

- Must be of original nameplate type.
- Must meet ARI Standard 700 (latest edition) specifications.

3. Recovered or Recycled Refrigerant

- Must be recovered or recycled in accordance with current local, state and federal laws.
- Must be recovered from and re-used in the same Manitowoc product. Re-use of recovered or recycled refrigerant from other products is not approved.
- Recycling equipment must be certified to ARI Standard 740 (latest edition) and be maintained to consistently meet this standard.
- Recovered refrigerant must come from a "contaminant-free" system. To decide whether the system is contaminant free, consider:
 - Type(s) of previous failure(s)
 - Whether the system was cleaned, evacuated and recharged properly following failure(s)
 - Whether the system has been contaminated by this failure
 - Compressor motor burnouts and improper past service prevent refrigerant re-use.
 - Refer to "System Contamination Cleanup" to test for contamination.

4. "Substitute" or "Alternative" Refrigerant

- Must use only Manitowoc-approved alternative refrigerants.
- Must follow Manitowoc-published conversion procedures.

HFC REFRIGERANT QUESTIONS AND ANSWERS

Manitowoc uses R-404A and R-134A HFC refrigerants with ozone depletion potential (ODP) factors of zero (0.0). R-404A is used in ice machines and reach-in freezers and R-134A is used in reach-in refrigerators.

1. What compressor oil does Manitowoc require for use with HFC refrigerants?

Manitowoc products use Polyol Ester (POE) type compressor oil. It is the lubricant of choice among compressor manufacturers.

2. What are some of the characteristics of POE oils?

They are hygroscopic, which means they have the ability to absorb moisture. POE oils are 100 times more hygroscopic than mineral oils. Once moisture is absorbed into the oil, it is difficult to remove, even with heat and vacuum. POE oils are also excellent solvents, and tend to “solvent clean” everything inside the system, depositing material where it is not wanted.

3. What do these POE oil characteristics mean to me?

You must be more exacting in your procedures. Take utmost care to prevent moisture from entering the refrigeration system. Refrigeration systems and compressors should not be left open to the atmosphere for more than 15 minutes. Keep oil containers and compressors capped at all times to minimize moisture entry. Before removing the system charge to replace a faulty component, be sure you have all of the needed components at the site. Remove new system component plugs and caps just prior to brazing. Be prepared to connect a vacuum pump immediately after brazing.

4. Are there any special procedures required if a POE system is diagnosed with a refrigerant leak?

For systems found with positive refrigerant system pressure, no special procedures are required.

For systems found without any positive refrigerant pressure, assume that moisture has entered the POE oil. After the leak is found and repaired, the compressor oil must be changed. The compressor must be removed and at least 95% of the oil drained from the suction port of the compressor. Use a “measuring cup” to replace the old oil with exactly the same amount of new POE oil, such as Mobil EAL22A.

Remember, care must be taken to prevent moisture from getting into the refrigeration system during refrigeration repairs.

5. How do I leak-check a system containing HFC refrigerant?

Use equipment designed for HFC detection. Do not use equipment designed for CFC detection. Consult leak detection equipment manufacturers for their recommendations. Also, standard soap bubbles will work with HFC refrigerants.

6. Does Manitowoc use a special liquid line filter-drier with HFC refrigerants?

Yes. Manitowoc uses an ALCO “UK” series filter-drier for increased filtration and moisture removal. During a repair, Manitowoc recommends installing the drier just before hooking up a vacuum pump.

Continued on next page...

7. Is other special equipment required to service HFC refrigerants?

No. Standard refrigeration equipment such as gauges, hoses, recovery systems, vacuum pumps, etc., are generally compatible with HFC refrigerants. Consult your equipment manufacturer for specific recommendations for converting existing equipment to HFC usage. Once designated (and calibrated, if needed) for HFC use, this equipment should be used specifically with HFC refrigerants only.

8. Do I have to recover HFC refrigerants?

Yes. Like other refrigerants, government regulations require recovering HFC refrigerants.

9. Will R-404A or R-134A separate if there is a leak in the system?

No. Like R-502, the degree of separation is too small to detect.

10. How do I charge a system with HFC refrigerant?

The same as R-502, Manitowoc recommends charging only liquid refrigerant into the high side of the system.

We reserve the right to make product improvements at any time.

Specifications and design are subject to change without notice.

MANITOWOC ICE, INC.

2110 South 26th Street P.O. Box 1720

Manitowoc, WI 54221-1720

Phone: (920) 682-0161

Fax: (920) 683-7585

Web Site - www.manitowocice.com

©2001 Manitowoc Ice, Inc.

Litho in U.S.A.