



Manitowoc



S Model Nugget/Flake Ice Machines

Installation, Use & Care Manual

This manual is updated as new information and models are released.
Visit our website for the latest manual. www.manitowocfsg.com

America's #1 Selling Ice Machine
Part Number 000001196 11/11

Manitowoc
Foodservice Group



Safety Notices

As you work on Manitowoc equipment, be sure to pay close attention to the safety notices in this manual. Disregarding the notices may lead to serious injury and/or damage to the equipment.

Throughout this manual, you will see the following types of safety notices:

Warning

Text in a Warning box alerts you to a potential personal injury situation. Be sure to read the Warning statement before proceeding, and work carefully.

Caution

Text in a Caution box alerts you to a situation in which you could damage the equipment. Be sure to read the Caution statement before proceeding, and work carefully.

Procedural Notices

As you work on Manitowoc equipment, be sure to read the procedural notices in this manual. These notices supply helpful information which may assist you as you work.

Throughout this manual, you will see the following types of procedural notices:

Important

Text in an Important box provides you with information that may help you perform a procedure more efficiently. Disregarding this information will not cause damage or injury, but it may slow you down as you work.

NOTE: Text set off as a Note provides you with simple, but useful, extra information about the procedure you are performing.

Read These Before Proceeding:

Caution

Proper installation, care and maintenance are essential for maximum performance and trouble-free operation of your Manitowoc equipment. Read and understand this manual. It contains valuable care and maintenance information. If you encounter problems not covered by this manual, do not proceed, contact Manitowoc Foodservice Group. We will be happy to provide assistance.

Important

Routine adjustments and maintenance procedures outlined in this manual are not covered by the warranty.

Warning

PERSONAL INJURY POTENTIAL

Do not operate equipment that has been misused, abused, neglected, damaged, or altered/modified from that of original manufactured specifications.

NOTE: SAVE THESE INSTRUCTIONS.

We reserve the right to make product improvements at any time. Specifications and design are subject to change without notice.

Table of Contents

Section 1

General Information

Model Numbers	1-1
How to Read a Model Number	1-1
Remote Condensing Unit	1-1
Manitowoc Cleaner and Sanitizer	1-2
Model/Serial Number Location	1-3
Owner Warranty Registration Card	1-4
General	1-4
Commercial Warranty Coverage	1-4
General	1-4
Parts	1-4
Labor	1-4
Exclusions	1-4
Authorized Warranty Service	1-4
Service Calls	1-4
Residential Ice Machine Limited Warranty	1-5

Section 2

Installation Instructions

Ice Machine Dimensions	2-1
Air Cooled Ice MachineS	2-1
Water Cooled Ice MachineS	2-2
Remote air Cooled Ice MachineS	2-3
QuietQube Remote Air Cooled Ice MachineS	2-3
Remote Unit Dimensions	2-4
Traditional Remote Condenser	2-4
30 inch (76 cm) Ice Storage Bins	2-4
Remote Condensing Unit	2-4
Location of Ice Machine	2-5
Ice Machine Clearance Requirements	2-5
Ice Machine Heat of Rejection	2-5
Location of Traditional Remote Units & Remote Condensing Units	2-5
Condensing Unit Clearance Requirements	2-5
Installing on a Storage Bin	2-6
Leveling the Ice Storage Bin	2-6
Installing on a Dispenser	2-6
Nugget Dispensing Kit Installation Procedure	2-6

Table of Contents (continued)

Condenser Air Baffle (Air-Cooled Ice Machines Only)	2-7
Electrical Service	2-8
Voltage	2-8
Fuse/Circuit Breaker	2-8
Minimum Circuit Ampacity	2-8
Ground Fault Circuit Interrupter	2-8
Electrical Requirements	2-8
Electrical Requirements	2-9
Ice Machine Head Section	2-9
QuietQube Remote Condensing Unit	2-9
SF400/SN0450/SF600/SN0650/SF900/SN0950/SF1200/SN1250 - Electrical Wiring Connections	2-10
Self Contained Ice Machine 115/1/60 or 208-230/1/60	2-10
Self Contained Ice Machine 208-230/3/60	2-10
Self Contained Ice Machine 230/1/50	2-10
SF600/SN0650 - Remote Electrical Wiring Connections	2-11
Remote Ice Machine 115/1/60 or 208-230/1/60	2-11
Remote Ice Machine 208-230/3/60	2-11
Remote Ice Machine 230/1/50	2-11
SF0900C/SN0950C/SF1200C/SN1250C Ice Machine Head Section Electrical Wiring Connections	2-12
Water Supply and Drains	2-13
Potable Water Supply	2-13
Potable Water Inlet Lines	2-13
Drain Connections	2-13
Cooling Tower Applications (Water-Cooled Models)	2-13
Water Supply and Drain Line Sizing/Connections	2-14
Refrigeration System Installation Traditional Remote Ice Machines Only ...	2-15
Refrigeration Line Set Installation Traditional Remote Ice Machines Only ...	2-16
General	2-16
Guidelines for Routing Line Sets	2-16
Calculating Remote Condenser Installation Distances	2-17
Lengthening or Reducing Line Set Lengths	2-18
Connecting A Line Set	2-18
Remote Receiver Service Valve	2-18

Table of Contents (continued)

Refrigeration System Installation Remote Condensing Unit Only	2-20
Refrigeration Line Set Installation Remote Condensing Unit Only	2-21
General	2-21
A. Line Set Length	2-21
B. Line Set Rise or Drop	2-21
C. Suction Line Oil Traps	2-22
Installation Checklist	2-31
Additional Checks for Remote Models	2-31
Section 3	
Operation	
Component Identification	3-1
Ice Machine Head Section	3-1
Operational Checks	3-2
General	3-2
Sequence of Operation	3-3
Prior to startup	3-3
Restart after Automatic Shutoff	3-3
Changing toggle switch position in the freeze cycle	3-3
Control Board Features	3-4
Flush Cycle	3-4
Power interruption delay	3-4
SafeGuards	3-4
Section 4	
Maintenance	
Cleaning and Sanitizing	4-1
General	4-1
Exterior Cleaning	4-1
Manitowoc's Cleaning Technology	4-2
Preventative Maintenance Cleaning Procedure	4-3
Procedure to Clean Heavily Scaled Flake/Nugget Ice Machines	4-4
Cleaning Procedure	4-5
Sanitizing Procedure	4-6
Component Disassembly For Cleaning And Sanitizing	4-7
Cleaning the Condenser	4-12
Removal from Service/Winterization	4-13
General	4-13

Section 5

Before Calling for Service

Checklist	5-1
Safeguard Feature	5-2
General	5-2
Determining Which SafeGuard Stopped the Ice Machine	5-2
SafeGuard Indicator Lights	5-2
Reset Procedure	5-2
SafeGuard Modes	5-3
No Water	5-3
No Ice production	5-4

 **Caution**

RFC Condensing Units: Energize the head section before the condensing unit. This allows the system pressure to equalize prior to energizing the condensing unit. Energizing the compressor while in a vacuum may cause immediate compressor failure.

Manitowoc Cleaner and Sanitizer

Manitowoc Ice Machine Cleaner and Sanitizer are available in convenient 16 oz. (473 ml) bottles. Sanitizer is also available in 1 gal (3.78 l) bottles. These are the only cleaner and sanitizer approved for use with Manitowoc products.

Cleaner Part Number		Sanitizer Part Number	
16 oz.	000000084	16 oz.	94-0565-3
		1 gallon	94-0581-3

 **Caution**

Ice machines on dispensers in low volume locations may experience congealing. Thermostat kit [K00364](#) must be added in these locations to prevent damage to the ice machine and dispenser.

Model/Serial Number Location

These numbers are required when requesting information from your local Manitowoc distributor, service representative, or Manitowoc Ice, Inc. Record the model and serial number of your ice machine and store in a convenient location.

The model and serial number are listed on the OWNER WARRANTY REGISTRATION CARD. They are also listed on the MODEL/SERIAL NUMBER DECAL affixed to the ice machine head section and condensing unit.

The decals are located on the end of the ice machine control box and on the back panel.

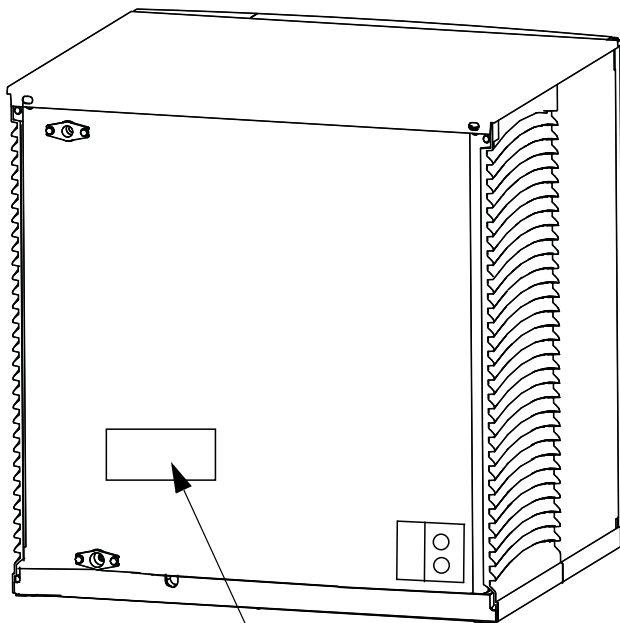

MODEL/SERIAL
NUMBER DECAL -
BACK PANEL

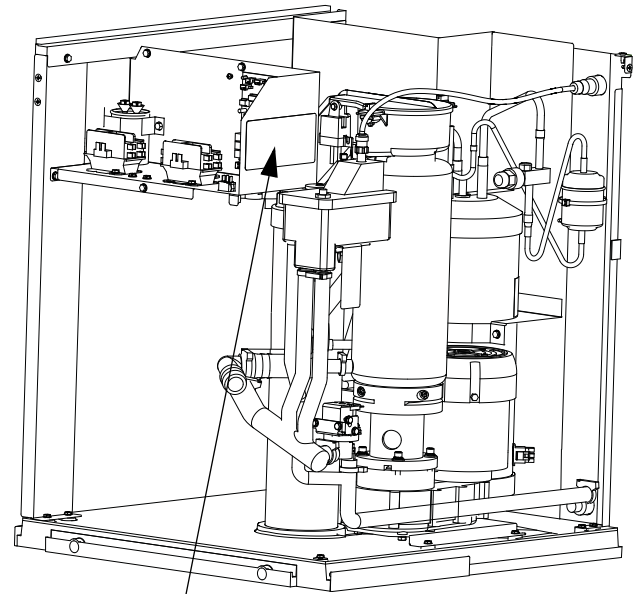

MODEL/SERIAL
NUMBER DECAL -
INSIDE MACHINE

Owner Warranty Registration Card

GENERAL

The packet containing this manual also includes warranty information. Warranty coverage begins the day the ice machine is installed.

Important

Complete and mail the OWNER WARRANTY REGISTRATION CARD as soon as possible to validate the installation date.

If the OWNER WARRANTY REGISTRATION CARD is not returned, Manitowoc will use the date of sale to the Manitowoc Distributor as the first day of warranty coverage for your new ice machine.

Commercial Warranty Coverage

GENERAL

The following Warranty outline is provided for your convenience. For a detailed explanation, read the warranty bond shipped with each product.

Contact your local Manitowoc Distributor or Manitowoc Ice, Inc. if you need further warranty information.

PARTS

1. Manitowoc warrants the ice machine against defects in materials and workmanship, under normal use and service for two (2) years from the date of original installation.
2. The compressor is covered by an additional three (3) year (five years total) warranty beginning on the date of the original installation.

LABOR

1. Labor required to repair or replace defective components is covered for two (2) years from the date of original installation.

EXCLUSIONS

The following items are not included in the ice machine's warranty coverage:

1. **Normal maintenance**, adjustments and cleaning as outlined in this manual.
2. Repairs due to unauthorized modifications to the ice machine or use of non-standard parts without prior written approval from Manitowoc Ice, Inc.
3. Damage caused by improper installation of the ice machine, electrical supply, water supply or drainage, or damage caused by floods, storms, or other acts of God.
4. **Premium labor rates** due to holidays, **overtime**, etc.; travel time; flat rate service call charges; mileage and miscellaneous tools and material charges not listed on the payment schedule. Additional labor charges resulting from the inaccessibility of equipment are also excluded.
5. Parts or assemblies subjected to misuse, abuse, neglect or accidents.
6. Damage or problems caused by installation, cleaning and/or maintenance procedures inconsistent with the technical instructions provided in this manual.

AUTHORIZED WARRANTY SERVICE

To comply with the provisions of the warranty, a refrigeration service company qualified and authorized by a Manitowoc distributor, or a Contracted Service Representative must perform the warranty repair.

NOTE: If the dealer you purchased the ice machine from is not authorized to perform warranty service; contact your Manitowoc distributor or Manitowoc Ice, Inc. for the name of the nearest authorized service representative.

SERVICE CALLS

Normal maintenance, adjustments and cleaning as outlined in this manual are not covered by the warranty. If you have followed the procedures listed in this manual, and the ice machine still does not perform properly, call your Local Distributor or the Service Department at Manitowoc Ice, Inc.

Residential Ice Machine Limited Warranty

WHAT DOES THIS LIMITED WARRANTY COVER?

Subject to the exclusions and limitations below, Manitowoc Ice, Inc. ("Manitowoc") warrants to the original consumer that any new ice machine manufactured by Manitowoc (the "Product") shall be free of defects in material or workmanship for the warranty period outlined below under normal use and maintenance, and upon proper installation and start-up in accordance with the instruction manual supplied with the Product.

HOW LONG DOES THIS LIMITED WARRANTY LAST?

<u>Product Covered</u>	<u>Warranty Period</u>
Ice Machine	Twelve (12) months from the sale date

WHO IS COVERED BY THIS LIMITED WARRANTY?

This limited warranty only applies to the original consumer of the Product and is not transferable.

WHAT ARE MANITOWOC ICE'S OBLIGATIONS UNDER THIS LIMITED WARRANTY?

If a defect arises and Manitowoc receives a valid warranty claim prior to the expiration of the warranty period, Manitowoc shall, at its option: (1) repair the Product at Manitowoc's cost, including standard straight time labor charges, (2) replace the Product with one that is new or at least as functionally equivalent as the original, or (3) refund the purchase price for the Product. Replacement parts are warranted for 90 days or the balance of the original warranty period, whichever is longer. The foregoing constitutes Manitowoc's sole obligation and the consumer's exclusive remedy for any breach of this limited warranty. Manitowoc's liability under this limited warranty is limited to the purchase price of Product. Additional expenses including, without limitation, service travel time, overtime or premium labor charges, accessing or removing the Product, or shipping are the responsibility of the consumer.

HOW TO OBTAIN WARRANTY SERVICE

To obtain warranty service or information regarding your Product, please contact us at:
 MANITOWOC ICE, INC.
 2110 So. 26th St.
 P.O. Box 1720,
 Manitowoc, WI 54221-1720
 Telephone: 920-682-0161 Fax: 920-683-7585
 www.manitowocice.com

WHAT IS NOT COVERED?

This limited warranty does not cover, and you are solely responsible for the costs of: (1) periodic or routine maintenance, (2) repair or replacement of the Product or parts due to normal wear and tear, (3) defects or damage to the Product or parts resulting from misuse, abuse, neglect, or accidents, (4) defects or damage to the Product or parts resulting from improper or unauthorized alterations, modifications, or changes; and (5) defects or damage to any Product that has not been installed and/or maintained in accordance with the instruction manual or technical instructions provided by Manitowoc. To the extent that warranty exclusions are not permitted under some state laws, these exclusions may not apply to you.

EXCEPT AS STATED IN THE FOLLOWING SENTENCE, THIS LIMITED WARRANTY IS THE SOLE AND EXCLUSIVE WARRANTY OF MANITOWOC WITH REGARD TO THE PRODUCT. ALL IMPLIED WARRANTIES ARE STRICTLY LIMITED TO THE DURATION OF THE LIMITED WARRANTY APPLICABLE TO THE PRODUCTS AS STATED ABOVE, INCLUDING BUT NOT LIMITED TO, ANY WARRANTY OF MERCHANTABILITY OR OF FITNESS FOR A PARTICULAR PURPOSE.

Some states do not allow limitations on how long an implied warranty lasts, so the above limitation may not apply to you.

IN NO EVENT SHALL MANITOWOC OR ANY OF ITS AFFILIATES BE LIABLE TO THE CONSUMER OR ANY OTHER PERSON FOR ANY INCIDENTAL, CONSEQUENTIAL OR SPECIAL DAMAGES OF ANY KIND (INCLUDING, WITHOUT LIMITATION, LOSS PROFITS, REVENUE OR BUSINESS) ARISING FROM OR IN ANY MANNER CONNECTED WITH THE PRODUCT, ANY BREACH OF THIS LIMITED WARRANTY, OR ANY OTHER CAUSE WHATSOEVER, WHETHER BASED ON CONTRACT, TORT OR ANY OTHER THEORY OF LIABILITY. Some states do not allow the exclusion or limitation of incidental or consequential damages, so the above limitation or exclusion may not apply to you.

HOW STATE LAW APPLIES

This limited warranty gives you specific legal rights, and you may also have rights that vary from state to state or from one jurisdiction to another.

REGISTRATION CARD

To secure prompt and continuing warranty service, this warranty registration card must be completed and sent to Manitowoc within thirty (30) days from the sale date. Complete the registration card and send it to Manitowoc.

THIS PAGE INTENTIONALLY LEFT BLANK

Section 2

Installation Instructions

Ice Machine Dimensions

These instructions are provided to assist the qualified installer. Check your local Yellow Pages for the name of the nearest Manitowoc distributor, or call Manitowoc Ice, Inc. for information regarding start-up services.

AIR COOLED ICE MACHINES

SF0400/SN0450/SF0600/SN0650/SF0900/SN0950

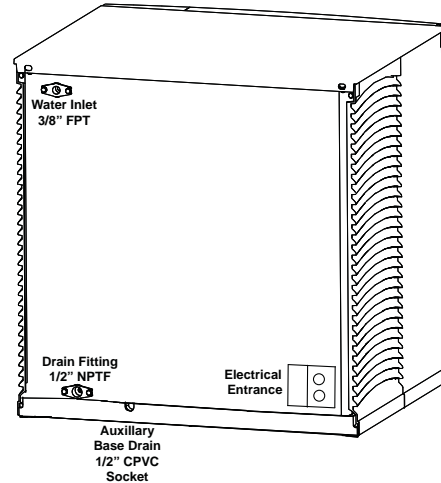
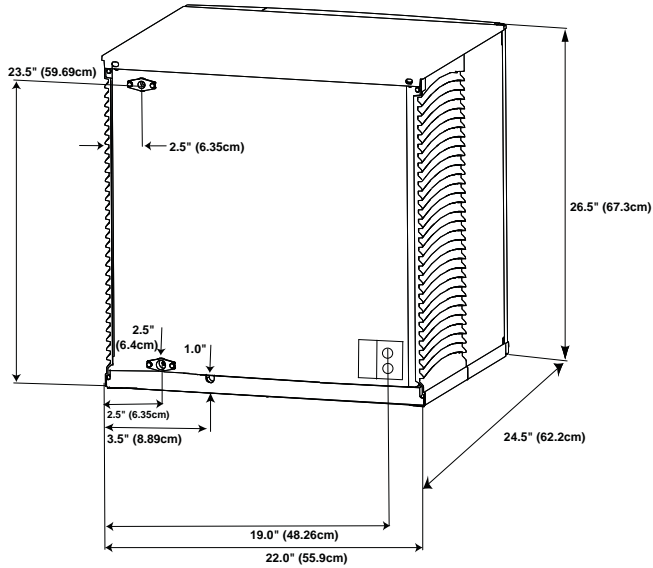

SF1200/SN1250

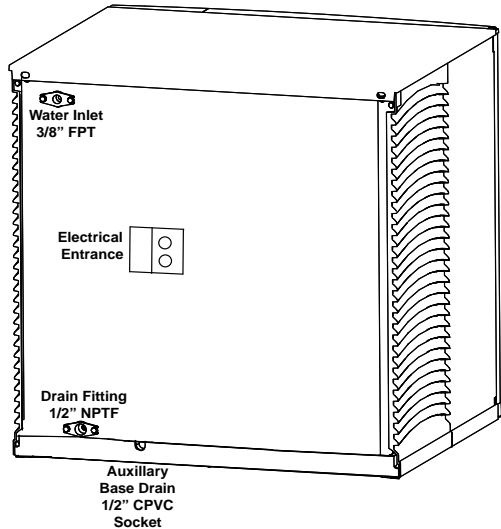
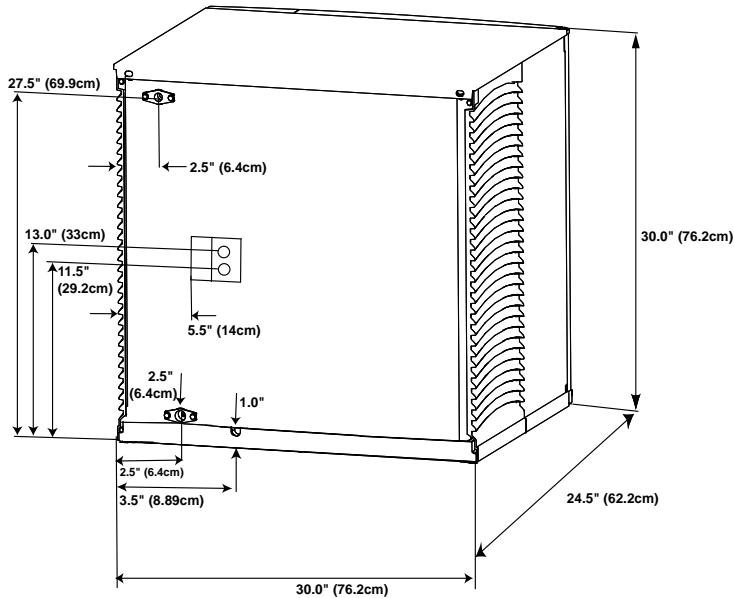

WATER COOLED ICE MACHINES

SF0400/SN0450/SF0600/SN0650/SF0900/SN0950

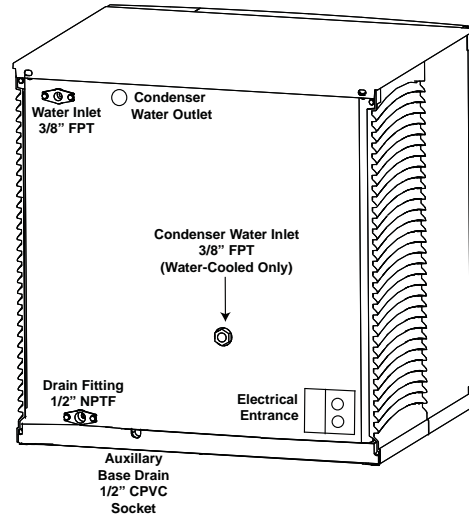
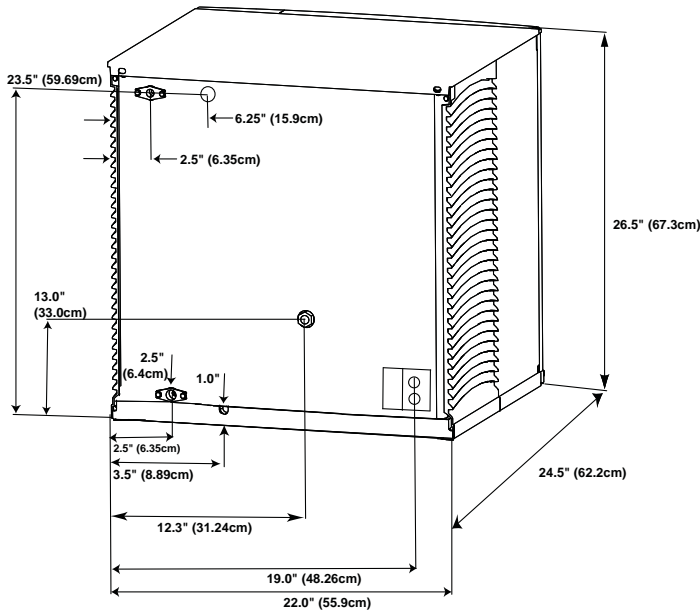

SF1200/SN1250

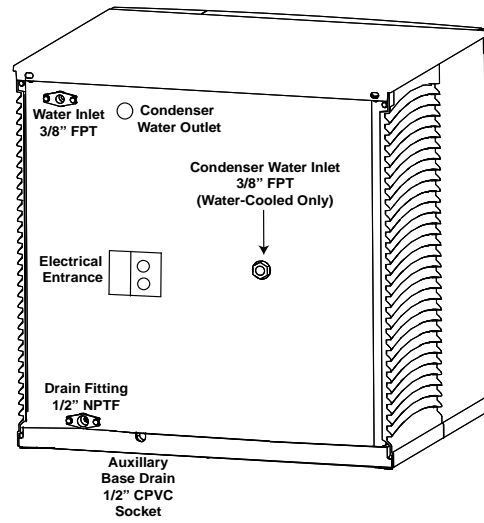
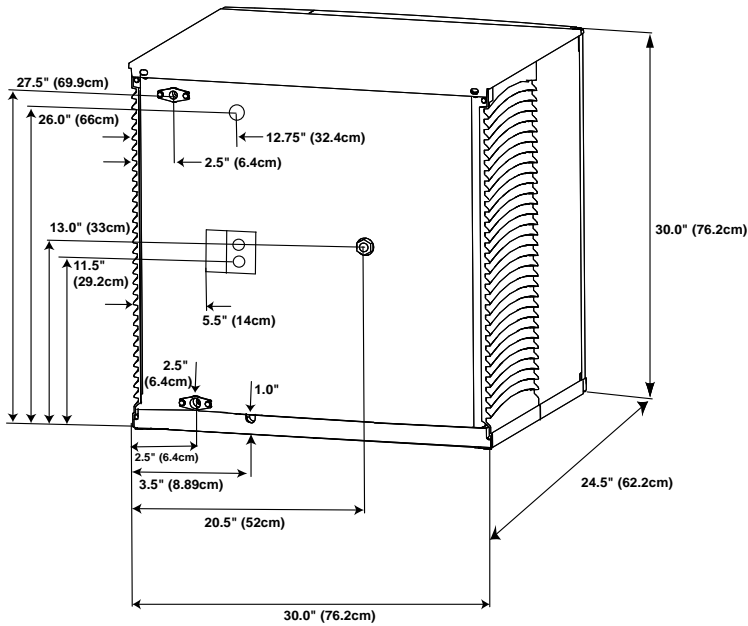

REMOTE AIR COOLED ICE MACHINES

SF0600/SN0650

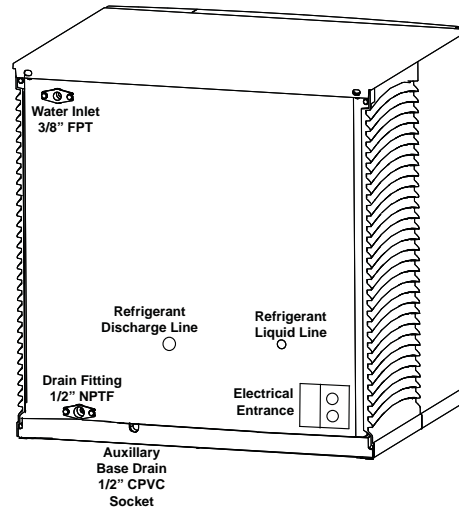
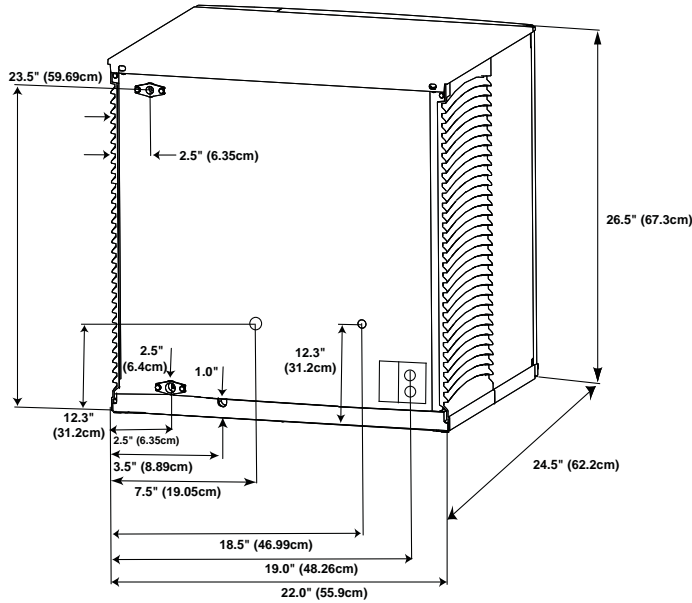

QUIETQUBE REMOTE AIR COOLED ICE MACHINES

SF0900C/SN0950C

SF1200C/SN1250C

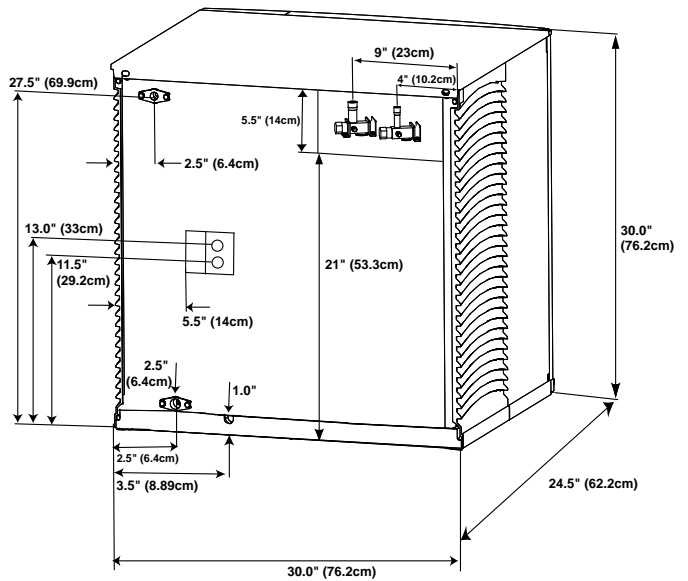
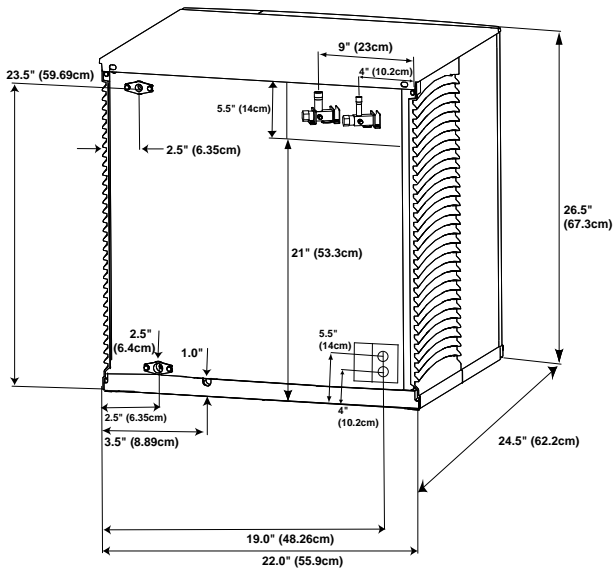

Remote Unit Dimensions

TRADITIONAL REMOTE CONDENSER

JC0495

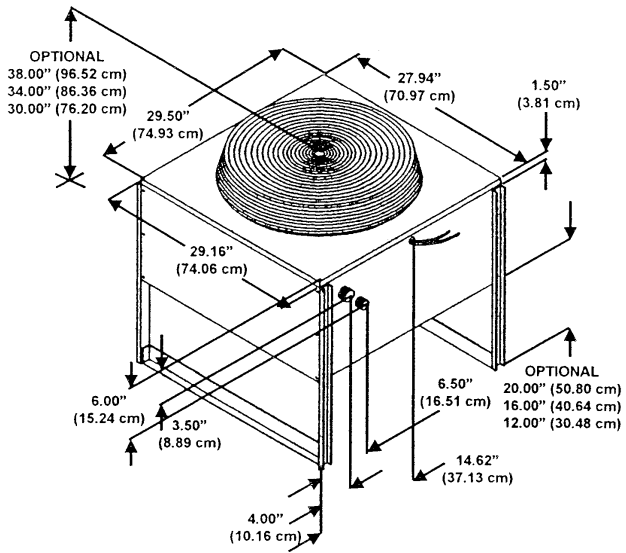

REMOTE CONDENSING UNIT

RFC0985/RFC1285

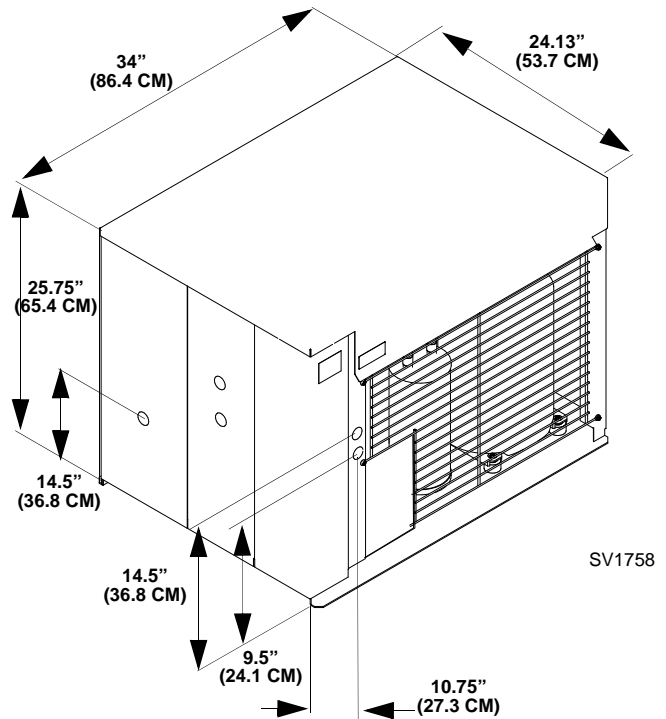

Ice Storage Bin Dimensions

30 INCH (76 CM) ICE STORAGE BINS

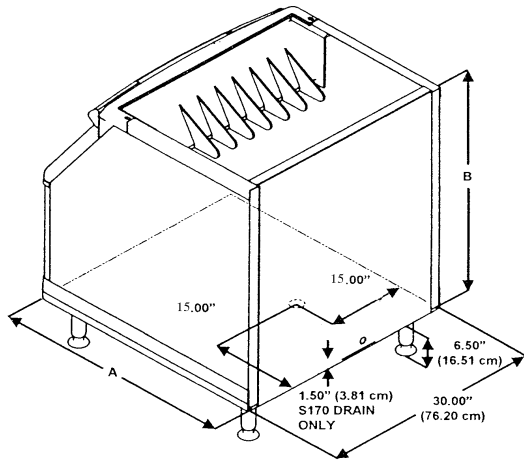

SV1609

Bin Model	Dimension A	Dimension B
B170	29.5 in (74.9 cm)	19.1 in (48.5 cm)
B400	34.0 in (86.3 cm)	32.0 in (81.3 cm)
B570	34.0 in (86.3 cm)	44.0 in (111.7 cm)

Location of Ice Machine

The location selected for the ice machine must meet the following criteria. If any of these criteria are not met, select another location.

- The location must be free of airborne and other contaminants.
- The air temperature must be at least 45°F (7°C), but must not exceed 110°F (43°C).
- The water temperature must be at least 45°F (7°C), but must not exceed 90°F (32°C).
- The location must not be near heat-generating equipment or in direct sunlight.
- The location must be capable of supporting the weight of the ice machine and a full bin of ice.
- The location must allow enough clearance for water, drain and electrical connections in the **rear of the ice machine**.
- The location must not obstruct airflow through or around the ice machine.
- RFC Condensing Units ONLY - Interconnecting wiring (115/60/1 or 230/50/1) is required between the ice machine and condensing unit to energize the contactor coil.

Ice Machine Clearance Requirements

SF400/SN450 SF600/SN650 SF900/SN950 SF1200/SN1250	Self-Contained Air-Cooled	Water-Cooled & Remote	QuietQube
Top/Sides	8" (20.3 cm)	8" (20.3 cm)	0" (0 cm)
Back	5" (12.7 cm)	5" (12.7 cm)	0" (0 cm)

⚠ Caution

The ice machine head section must be protected if it will be subjected to temperatures below 32°F (0°C). Failure caused by exposure to freezing temperatures is not covered by the warranty. See "Removal from Service/Winterization".

Ice Machine Heat of Rejection

Ice Machine Model	Heat of Rejection	
	Air Conditioning	Peak
SF0400/SN0450	3,900 btuh	5,800 btuh
SF0600/SN0650	5,600 btuh	8,300 btuh
SF0900/SN0950	7,000 btuh	13,000 btuh
SF1200/SN1250	10,800 btuh	18,500 btuh

Ice machines, like other refrigeration equipment, reject heat through the condenser. It is helpful to know the amount of heat rejected by the ice machine when sizing air conditioning equipment where self-contained air-cooled ice machines are installed.

This information is also necessary when evaluating the benefits of using water-cooled or remote condensers to reduce air conditioning loads. The amount of heat added to an air conditioned environment by an ice machine using a water-cooled or remote condenser is negligible.

Knowing the amount of heat rejected is also important when sizing a cooling tower for a water-cooled condenser. Use the peak figure for sizing the cooling tower.

Location of Traditional Remote Units & Remote Condensing Units

The location selected for the Remote Units must meet the following criteria. If any of these criteria are not met, select another location.

- The air temperature must be at least -20°F (-28.9°C) but must not exceed 120°F (49°C).
- The location must not allow exhaust fan heat and/or grease to enter the condenser.
- The location must not obstruct airflow through or around the condensing unit. Refer to the chart below for clearance requirements.
- RFC Condensing Units ONLY - Interconnecting wiring (115/60/1) is required between the ice machine and condensing unit to energize the contactor coil.

CONDENSING UNIT CLEARANCE REQUIREMENTS

Remote Condenser/Condensing Unit Clearances	
JC0495 Top/Bottom	Bottom clearance is 12" (31 cm) Top clearance is 4' (1.2 m)
JC0495 Sides	There is no minimum clearance required, although 6" (15 cm) is recommended for efficient operation and servicing only.
RFC - Top/Sides	There is no minimum clearance required, although 6" (15 cm) is recommended for efficient operation and servicing only.
RFC - Front/Back	4' (1.2 m)

Installing on a Storage Bin

LEVELING THE ICE STORAGE BIN

1. Screw the leveling legs onto the bottom of the bin.
2. Screw the foot of each leg in as far as possible.

⚠ Caution

The legs must be screwed in tightly to prevent them from bending.

3. Move the bin into its final position.
4. Level the bin to assure that the bin door closes and seals properly. Use a level on top of the bin. Turn each foot as necessary to level the bin.
5. Inspect bin gasket prior to ice machine installation. (Manitowoc bins come with closed cell foam gasket installed along the top surface of the bin.)
6. Install ice machine on bin.

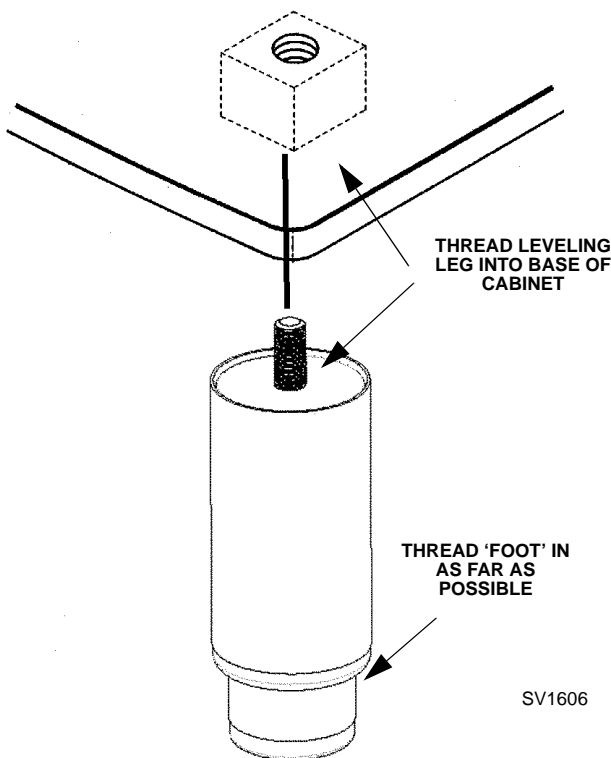

Leveling Leg and Foot

Installing on a Dispenser

Nugget ice is soft and chewable. This characteristic makes this ice more difficult to dispense. All dispenser manufacturers require a kit be installed for Nugget type ice. Contact the dispenser manufacturer for the correct adapter and nugget dispensing kit for your specific model dispenser. The required kit can vary by dispenser size from the same manufacturer.

Failure to install the correct kit and make the necessary modifications on the dispenser will result in:

- Congealed ice which will not dispense and will damage the ice machine and dispenser
- Insufficient ice contact with the cold plate which will result in an inferior product
- A safety issue if ice lifts the adapter or ice machine

NUGGET DISPENSING KIT INSTALLATION PROCEDURE

1. Follow the dispenser manufacturers instructions for installation of the adapter (if required) and nugget ice kit.
2. Make all necessary beverage, electrical and drain connections to the dispenser.
3. Level the dispenser front to back and side to side.
4. Install ice machine on dispenser and secure ice machine, dispenser and adapter with provided brackets.
5. Complete water, drain and electrical connections to the ice machine.

⚠ Warning

PERSONAL INJURY POTENTIAL

The ice machine and adapter must be attached to the dispenser to prevent the ice machine from falling.

⚠ Caution

Ice machines in low volume locations may experience congealing. Thermostat kit [K00364](#) must be added in these locations to prevent damage to the ice machine and dispenser.

Condenser Air Baffle (Air-Cooled Ice Machines Only)

The air-cooled baffle prevents condenser air from recirculating. To install:

1. Remove the back panel screws next to the condenser.
2. Align the mounting holes in the air baffle with the screw holes and reinstall the screws.

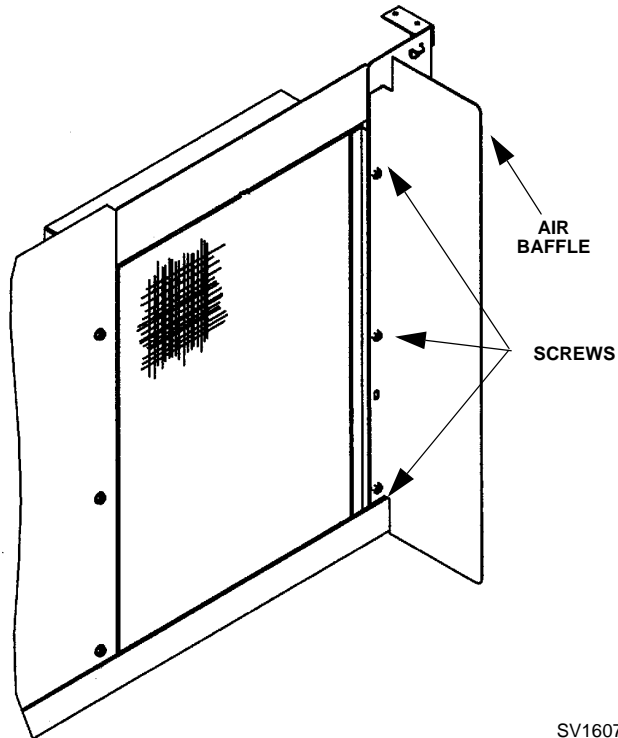

SV1607

Air Baffle

Electrical Service

Caution

RFC Condensing Units: Energize the head section before the condensing unit. This allows the system pressure to equalize prior to energizing the condensing unit. Energizing the compressor while in a vacuum may cause immediate compressor failure.

Warning

All wiring must conform to local, state and national codes.

VOLTAGE

The maximum allowable voltage variation is $\pm 10\%$ of the rated voltage at ice machine start-up (when the electrical load is highest).

Warning

The ice machine must be grounded in accordance with national and local electrical codes.

All electrical work, including wire routing and grounding, must conform to local, state and national electrical codes. The following precautions must be observed:

- The ice machine must be grounded.
- A separate fuse/circuit breaker must be provided for each ice machine.
- A qualified electrician must determine proper wire size dependent upon location, materials used and length of run (minimum circuit ampacity can be used to help select the wire size).
- The maximum allowable voltage variation is $\pm 10\%$ of the rated voltage at ice machine start-up (when the electrical load is highest).
- Check all green ground screws in the control box and verify they are tight before starting the ice machine.

Important

Observe correct polarity of incoming line voltage.

Incorrect polarity can lead to erratic ice machine operation and a safety issue. This is especially critical on 230 volt / 50 cycle ice machines.

FUSE/CIRCUIT BREAKER

A separate fuse/circuit breaker must be provided for each ice machine. Circuit breakers must be H.A.C.R. rated (does not apply in Canada).

MINIMUM CIRCUIT AMPACITY

The minimum circuit ampacity is used to help select the wire size of the electrical supply. (Minimum circuit ampacity is not the ice machine's running amp load.)

The wire size (or gauge) is also dependent upon location, materials used, length of run, etc., so it must be determined by a qualified electrician.

GROUND FAULT CIRCUIT INTERRUPTER

Ground Fault Circuit Interrupter (GFCI/GFI) protection is a system that shuts down the electric circuit (opens it) when it senses an unexpected loss of power, presumably to ground. Manitowoc Ice, Inc. does not recommend the use of a GFCI/GFI circuit protection with our equipment. If code requires the use of a GFCI/GFI then you must follow the local code. The circuit must be dedicated, sized properly and there must be a panel GFCI/GFI breaker. We do not recommend GFCI/GFI outlets as they are known for more intermittent nuisance trips than panel breakers.

SF900C/SN0950C/SF1200C/SN1250C with Remote Condensing Unit the ice machine head section and remote condensing unit are wired independent of each other. A separate dedicated fuse/circuit breaker must be provided for each section. Circuit breakers must be H.A.C.R. rated (does not apply in Canada).

RFC Condensing Units ONLY - Interconnecting wiring (115/60/1 or 230/50/1) is required between the ice machine and condensing unit to energize the contactor coil.

ELECTRICAL REQUIREMENTS

Refer to Ice Machine Model/Serial Plate for voltage/ amperage specifications.

Electrical Requirements

ICE MACHINE HEAD SECTION

Ice Machine Head Section	Voltage Phase Cycle	Air-Cooled		Water Cooled		QuietQube Air-Cooled	
		Maximum Fuse/Circuit Breaker	Minimum Circuit Amps	Maximum Fuse/Circuit Breaker	Minimum Circuit Amps	Maximum Fuse/Circuit Breaker	Minimum Circuit Amps
SF0400	115/1/60	20	13.7	20	12.9	Option Not Available	
	230/1/50	15	7.2	15	6.6		
SN0450	115/1/60	20	13.7	20	12.9	Option Not Available	
	230/1/50	15	7.2	15	6.6		
SF0600	115/1/60	20	16.2	20	15.5	Option Not Available	
	230/1/50	15	7.0	15	6.7		
SN0650	115/1/60	20	16.2	20	15.5	Option Not Available	
	230/1/50	15	7.0	15	6.7		
SF0600N Remote	115/1/60	20	17.9	Option Not Available		Option Not Available	
	230/1/50	Option Not Available					
SN0650N Remote	115/1/60	20	17.9	Option Not Available		Option Not Available	
	230/1/50	Option Not Available					
SF0900	115/1/60	Option Not Available		Option Not Available		15	1.7
	230/1/60	15	8.0	15	7.7	Option Not Available	
	230/1/50	15	7.0	15	6.7	15	1.2
SN0950	115/1/60	Option Not Available		Option Not Available		15	1.7
	230/1/60	15	8.0	15	7.7	Option Not Available	
	230/1/50	15	7.0	15	6.7	15	1.2
SF1200	115/1/60	Option Not Available		Option Not Available		15	1.7
	230/1/60	15	9.0	15	8.7	Option Not Available	
	230/1/50	15	8.0	15	7.7	15	1.2
SN1250	115/1/60	Option Not Available		Option Not Available		15	1.7
	230/1/60	15	9.0	15	8.7	Option Not Available	
	230/1/50	15	8.0	15	7.7	15	1.2

RFC Condensing Units ONLY - Interconnecting wiring (115/60/1) is required between the ice machine and condensing unit to energize the contactor coil.

QUIETQUBE REMOTE CONDENSING UNIT

Condensing Unit	Voltage PhaseCycle	Maximum Fuse/Circuit Breaker	Minimum Circuit Amps
RFC0985	208-230/1/60	15	8.6
	208-230/1/50	15	8.0
RFC1285	208-230/1/60	15	9.2
	208-230/3/60	15	6.8
	208-230/1/50	15	8.7

**SF400/SN0450/SF600/SN0650/SF900/SN0950/SF1200/SN1250 -
Electrical Wiring Connections**

Warning

These diagrams are not intended to show proper wire routing, wire sizing, disconnects, etc., only the correct wire connections.

All electrical work, including wire routing and grounding, must conform to local, state and national electrical codes.

Though wire nuts are shown in the drawings, the ice machine field wiring connections may use either wire nuts or screw terminals.

**SELF CONTAINED ICE MACHINE
115/1/60 OR 208-230/1/60**

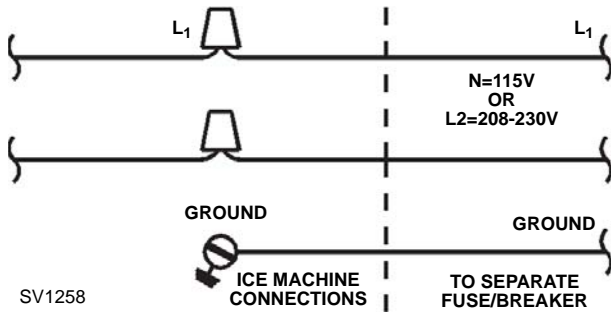

**SELF CONTAINED ICE MACHINE
208-230/3/60**

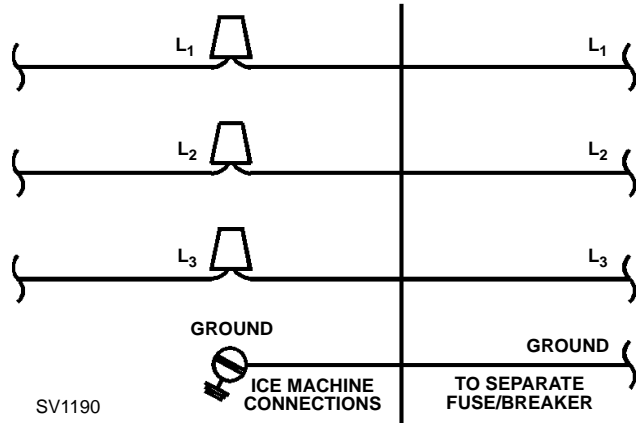

**SELF CONTAINED ICE MACHINE
230/1/50**

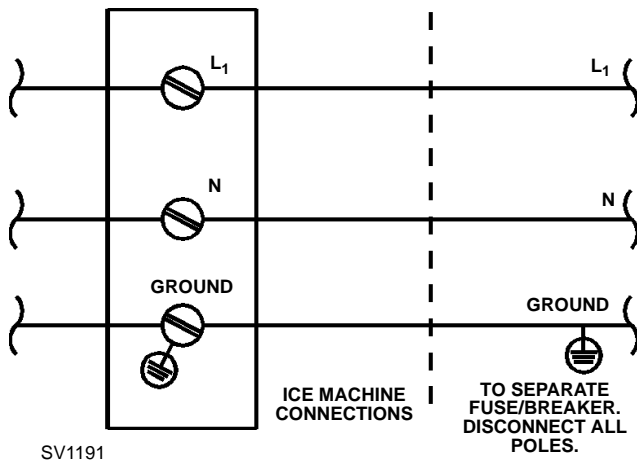

SF600/SN0650 - Remote Electrical Wiring Connections

Warning

These diagrams are not intended to show proper wire routing, wire sizing, disconnects, etc., only the correct wire connections.

All electrical work, including wire routing and grounding, must conform to local, state and national electrical codes.

Though wire nuts are shown in the drawings, the ice machine field wiring connections may use either wire nuts or screw terminals.

Important

F1 & F2 wires are located in the junction box on the rear of the ice machine. the wires are labeled F1 & F2 and are capped with a wire nut.

**REMOTE ICE MACHINE
115/1/60 OR 208-230/1/60**

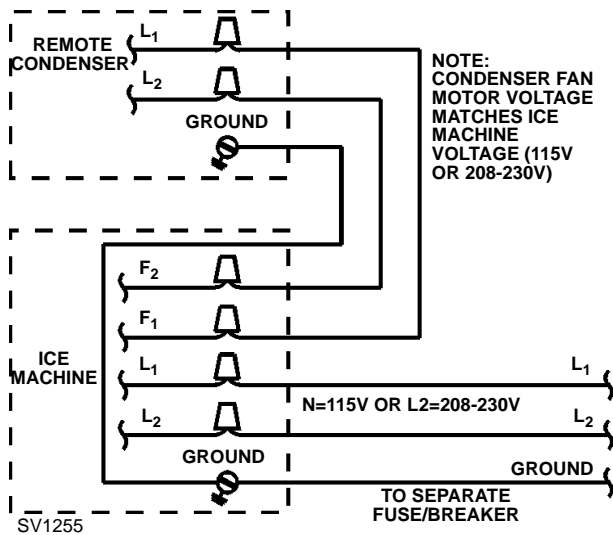

**REMOTE ICE MACHINE
208-230/3/60**

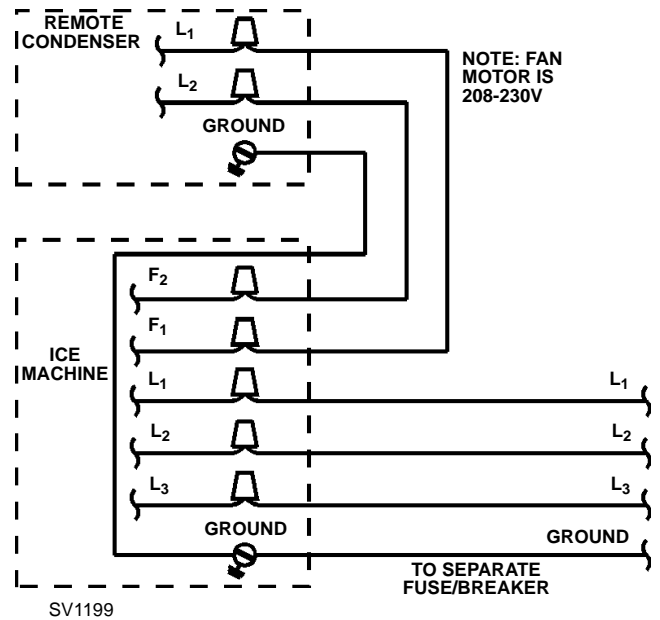

**REMOTE ICE MACHINE
230/1/50**

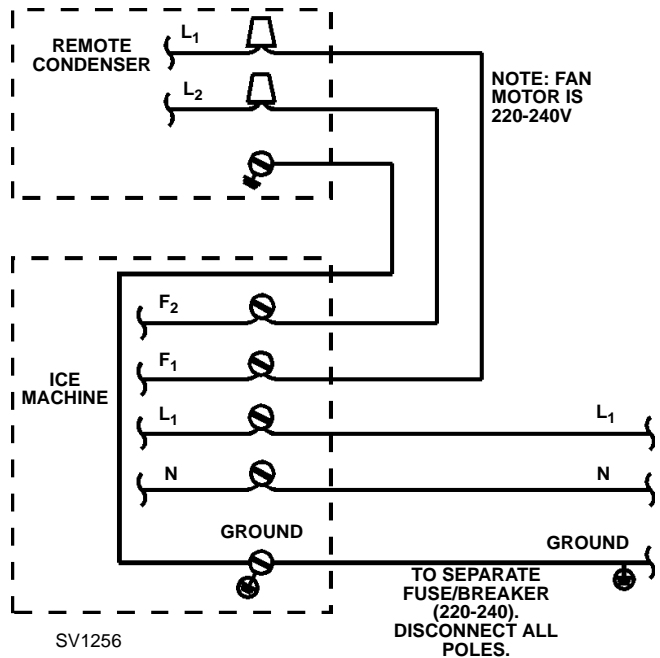

**SF0900C/SN0950C/SF1200C/SN1250C
Ice Machine Head Section Electrical Wiring
Connections**

115/60/1 & 208-230/1/50

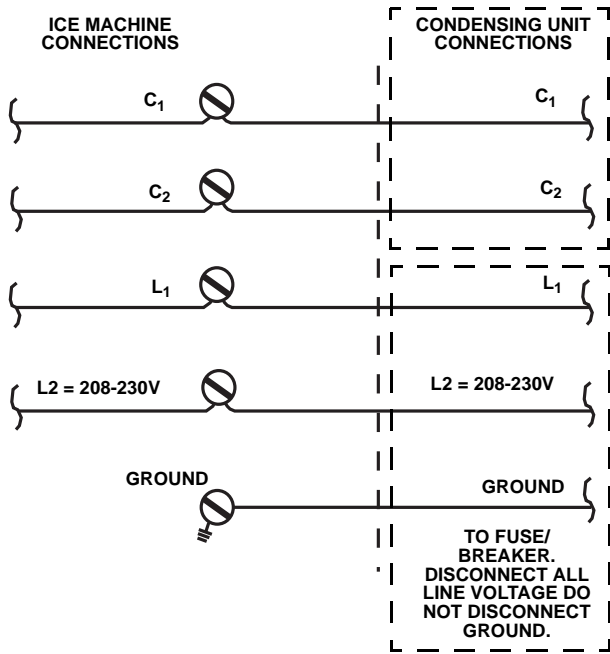

⚠ Warning

These diagrams are not intended to show proper wire routing, wire sizing, disconnects, etc., only the correct wire connections.

All electrical work, including wire routing and grounding, must conform to local, state and national electrical codes.

Though wire nuts are shown in the drawings, the ice machine field wiring connections may use either wire nuts or screw terminals.

Water Supply and Drains

POTABLE WATER SUPPLY

Local water conditions may require treatment of the water to inhibit scale formation, filter sediment, and remove chlorine odor and taste.

Important

If you are installing a Manitowoc water filter system, refer to the Installation Instructions supplied with the filter system for ice making water inlet connections.

POTABLE WATER INLET LINES

Follow these guidelines to install water inlet lines:

- Do not connect the ice machine to a hot water supply. Be sure all hot water restrictors installed for other equipment are working. (Check valves on sink faucets, dishwashers, etc.)
- If water pressure exceeds the maximum (80 psig 5.52 bar) recommended pressure, obtain a water pressure regulator from your Manitowoc distributor.
- Install a water shut-off valve and union for both the ice making and condenser water lines.
- Insulate water inlet lines to prevent condensation.

DRAIN CONNECTIONS

Follow these guidelines when installing drain lines to prevent drain water from flowing back into the ice machine and storage bin:

- Drain lines must have a 1.5 inch drop per 5 feet of run (2.5 cm per meter), and must not create traps.
- The floor drain must be large enough to accommodate drainage from all drains.
- Run separate bin and water-cooled condenser drain lines. Insulate them to prevent condensation.
- Vent the bin and ice machine drain to the atmosphere. The ice machine drain requires an 18" vent. Do not vent the condenser drain on water-cooled models.
- Drains must have a union or other suitable means to allow in place disconnection from the ice machine when servicing is required.

Cooling Tower Applications (Water-Cooled Models)

A water cooling tower installation does not require modification of the ice machine. The water regulator valve for the condenser continues to control the refrigeration discharge pressure.

It is necessary to know the amount of heat rejection, and the pressure drop through the condenser and water valves (inlet and outlet) when using a cooling tower on an ice machine.

- Water entering the condenser must not exceed 90°F (32°C).
- Water flow through the condenser must not exceed 5 gallons (19 liters) per minute.
- Allow for a pressure drop of 7 psi (0.48 bar) between the condenser water inlet and the outlet of the ice machine.
- Water exiting the condenser must not exceed 110°F (43°C).

Important

The Commonwealth of Massachusetts requires that all water-cooled models must be connected only to a closed loop, cooling tower system.

WATER SUPPLY AND DRAIN LINE SIZING/CONNECTIONS

Caution
 Plumbing must conform to national, state and local codes.

Location	Water Temperature	Water Pressure	Ice Machine Fitting	Tubing Size Up to Ice Machine Fitting
Ice Making Water Inlet	45°F (7°C) Min. 90°F (32°C) Max.	20 psi (1.4 bar) Min. 80 psi (5.5 bar) Max.	3/8" Female Pipe Thread	3/8" (9.5 mm) minimum inside diameter
Condenser Water Inlet	33°F (0.6°C) Min. 90°F (32°C) Max.	20 psi (1.4 bar) Min. 150 psi (10.3 bar) Max.	1/2" Female Pipe Thread	1/2" (12.7 mm) minimum inside diameter
Condenser Water Drain	---	---	1/2" Female Pipe Thread	1/2" (12.7 mm) minimum inside diameter
Bin Drain	---	---	3/4" Female Pipe Thread	3/4" (19.0 mm) minimum inside diameter

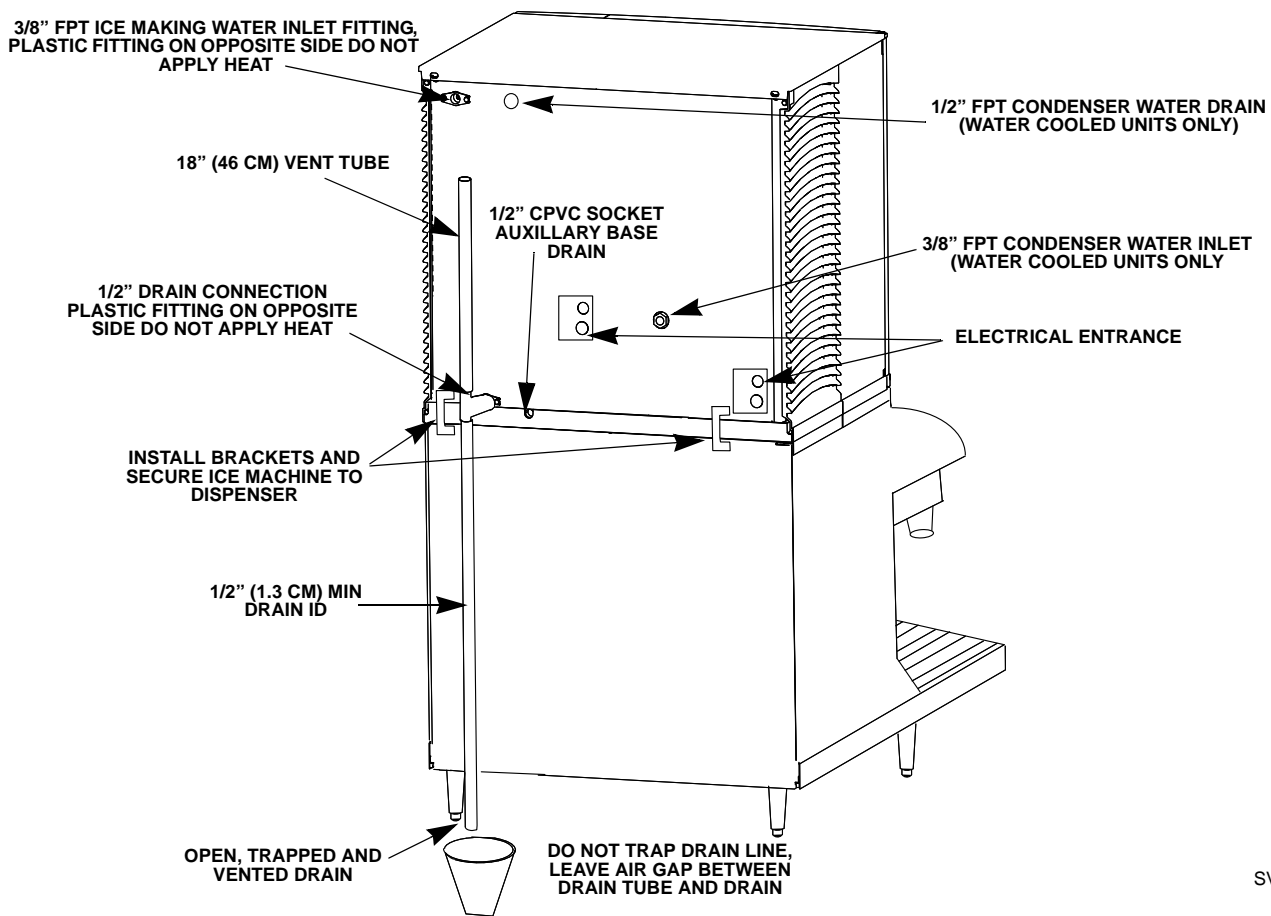

Typical Water Supply Drain Installation

SV3142

**Refrigeration System Installation
Traditional Remote Ice Machines Only**

Traditional Remote Ice Machine	Remote Single Circuit Condenser	Line Set*
SF600 SN650	JC0495	RM-20 RM-35 RM-50
*Lineset	Liquid Line	Discharge Line
RM20/35/50	1/4"	5/16"

Air Temperature Around the Condenser	
Minimum	Maximum
-20°F (-29°C)	120°F (49°C)

Warning
Installation of a Remote Condenser may require the use of special equipment for placement. Trained and qualified personnel are required for proper rigging and lifting.

Caution
The 60-month compressor warranty (including the 24-month labor replacement warranty) will not apply if the Manitowoc Ice Machine and remote condenser are not installed according to specifications. This warranty also will not apply if the refrigeration system is modified with a condenser, heat reclaim device, or other parts or assemblies not manufactured by Manitowoc Ice, Inc.

Important
Manitowoc remote systems are only approved and warranted as a complete new package. Warranty on the refrigeration system will be void if a new ice machine head section is connected to pre-existing (used) tubing or remote condensers.

Factory Equipment Refrigeration Amounts

ICE MACHINE HEAD SECTION

Each ice machine head section ships from the factory with a R-404A refrigerant charge appropriate for line sets up to 50' in length. The serial tag on the ice machine indicates the refrigerant charge. The ice machine may need additional refrigerant for line set lengths between 50' and 100' see chart below.

Ice Machine	Additional Refrigerant Required
SF0600	None
SN0650	None

Caution
Never add more than nameplate charge to the refrigeration system for any application.

Caution
Manitowoc SN Model ice machines are not approved for use with non-Manitowoc traditional condensers or remote condensing units. The 60-month compressor warranty (including the 24-month labor replacement warranty) will not apply if Manitowoc SN Model Ice Machines are installed with a non-Manitowoc traditional condenser or remote condensing unit.

Refrigeration Line Set Installation Traditional Remote Ice Machines Only

GENERAL

Condensers must be mounted horizontally with the fan motor on top.

Remote condenser installations consist of vertical and horizontal line sets between the ice machine and the condenser. When combined, they must fit within approved specifications. The following guidelines, drawings and calculation methods must be followed to verify a proper remote condenser installation.

Caution

The 60 month compressor warranty (including the 24 month labor replacement warranty) will not apply if the remote ice machine is not installed according to specifications.

This warranty also will not apply if the refrigeration system is modified with a condenser, heat reclaim device, or other parts or assemblies not manufactured by Manitowoc Ice, Inc., unless specifically approved in writing by Manitowoc Ice, Inc.

GUIDELINES FOR ROUTING LINE SETS

First, cut a 2.5" (6.35 cm) circular hole in the wall or roof for tubing routing. The line set end with the 90° bend will connect to the ice machine. The straight end will connect to the remote condenser.

Follow these guidelines when routing the refrigerant lines. This will help insure proper performance and service accessibility.

1. Optional - Make the service loop in the line sets (as shown below). This permits easy access to the ice machine for cleaning and service. Do not use hard rigid copper at this location.
2. Required - Do not form traps in the refrigeration lines (except the service loop). Refrigerant oil must be free to drain toward the ice machine or the condenser. Route excess tubing in a supported downward horizontal spiral (as shown below). Do not coil tubing vertically.
3. Required - Keep outdoor refrigerant line runs as short as possible.

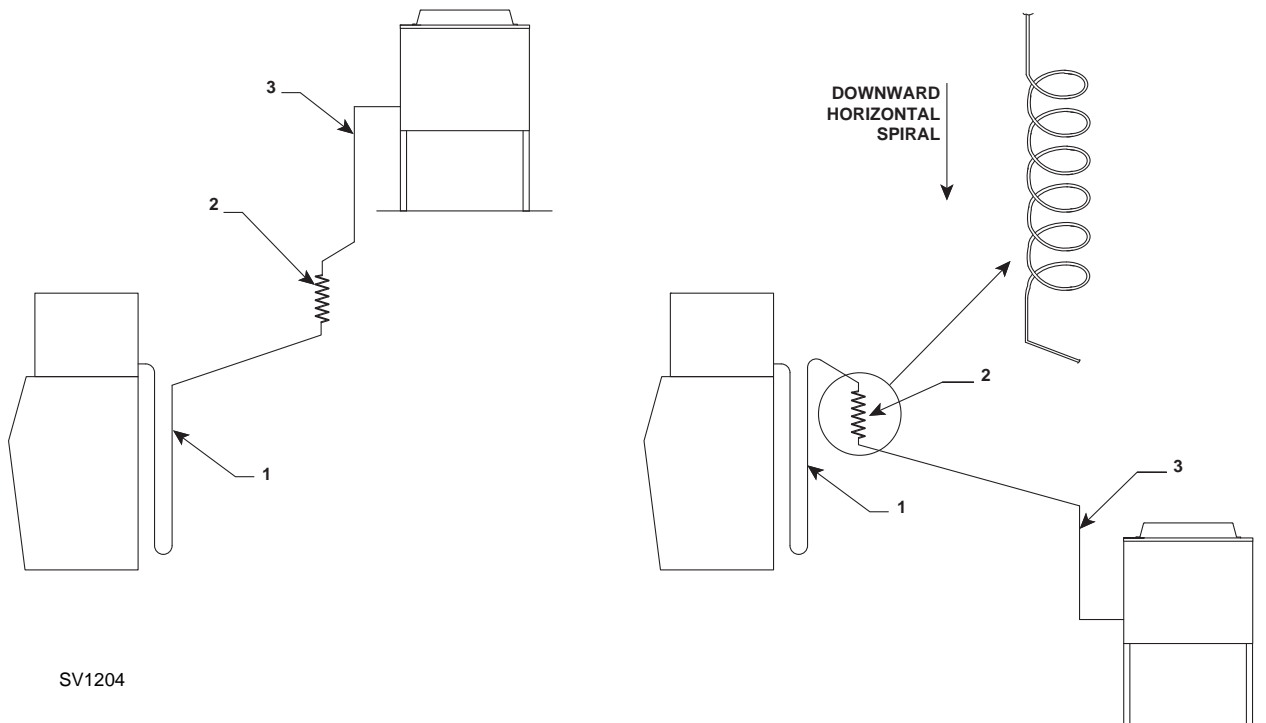

SV1204

Routing Line Sets

CALCULATING REMOTE CONDENSER INSTALLATION DISTANCES

Line Set Length

The maximum length is 100' (30.5 m).

The ice machine compressor must have the proper oil return. The receiver is designed to hold a charge sufficient to operate the ice machine in ambient temperatures between -20°F (-29°C) and 120°F (49°C), with line set lengths of up to 100' (30.5 m).

Line Set Rise/Drop

The maximum rise is 35' (10.7 m).

The maximum drop is 15' (4.5 m).

⚠ Caution

If a line set has a rise followed by a drop, another rise cannot be made. Likewise, if a line set has a drop followed by a rise, another drop cannot be made.

Make the following calculations to make sure the line set layout is within specifications.

1. Insert the **measured rise** into the formula below. Multiply by 1.7 to get the **calculated rise**.
(Example: A condenser located 10 feet above the ice machine has a **calculated rise** of 17 feet.)
2. Insert the **measured drop** into the formula below. Multiply by 6.6 to get the **calculated drop**.
(Example. A condenser located 10 feet below the ice machine has a **calculated drop** of 66 feet.)
3. Insert the **measured horizontal distance** into the formula below. No calculation is necessary.
4. Add together the **calculated rise**, **calculated drop**, and **horizontal distance** to get the **total calculated distance**. If this total exceeds 150' (45.7 m), move the condenser to a new location and perform the calculations again.

Calculated Line Set Distance

The maximum calculated distance is 150' (45.7 m).

Line set rises, drops, horizontal runs (or combinations of these) in excess of the stated maximums will exceed compressor start-up and design limits. This will cause poor oil return to the compressor.

Maximum Line Set Distance Formula

Step 1.	Measured Rise (35' [10.7 m] Maximum)	_____ x 1.7	=	_____	Calculated Rise
Step 2.	Measured Drop (15' [4.5 m] Maximum)	_____ x 6.6	=	_____	Calculated Drop
Step 3.	Measured Horizontal Distance (100' [30.5 m] Maximum)			_____	Horizontal Distance
Step 4.	Total Calculated Distance 150' (45.7 m)			_____	Total Calculated Distance

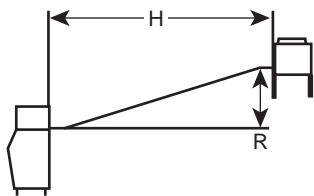

SV1196

Combination of a Rise and a Horizontal Run

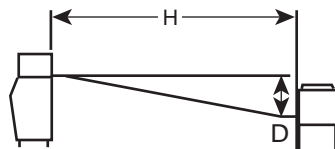

SV1195

Combination of a Drop and a Horizontal Run

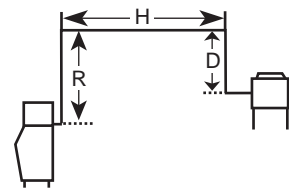

SV1194

Combination of a Rise, a Drop and a Horizontal Run

LENGTHENING OR REDUCING LINE SET LENGTHS

In most cases, by routing the line set properly, shortening will not be necessary. When shortening or lengthening is required, do so before connecting the line set to the ice machine or the remote condenser. This prevents the loss of refrigerant in the ice machine or condenser.

The quick connect fittings on the line sets are equipped with Schraeder valves. Use these valves to recover any vapor charge from the line set. When lengthening or shortening lines follow good refrigeration practices, purge with nitrogen and insulate all tubing. Do not change the tube sizes. Evacuate the lines and place about 5 oz (143g) of vapor refrigerant charge in each line.

CONNECTING A LINE SET

1. Remove the dust caps from the line set, condenser and ice machine.
2. Apply refrigeration oil to the threads on the quick disconnect couplers before connecting them to the condenser.
3. Carefully thread the female fitting to the condenser or ice machine by hand.
4. Tighten the couplings with a wrench until they bottom out.
5. Turn an additional 1/4 turn to ensure proper brass-to-brass seating. Torque to the following specifications:

Liquid Line	Discharge Line
10-12 ft lb. (13.5-16.2 N•m)	35-45 ft lb. (47.5-61.0 N•m)

6. Check all fittings and valve caps for leaks.
7. Make sure Schraeder cores are seated and Schraeder caps are on and tight.

REMOTE RECEIVER SERVICE VALVE

The receiver service valve is closed during shipment. Open the valve prior to starting the ice machine.

1. Remove the top and left side panels.
2. Remove the receiver service valve cap.
3. Backseat (open) the valve.
4. Reinstall the cap and panels.

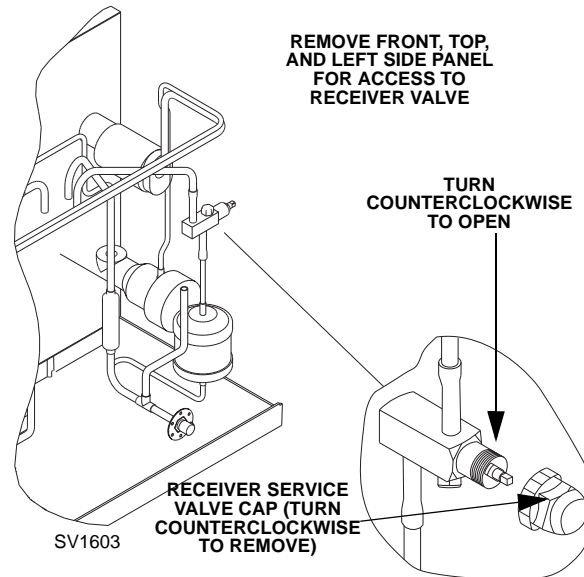

Backseating the Receiver Service Valve

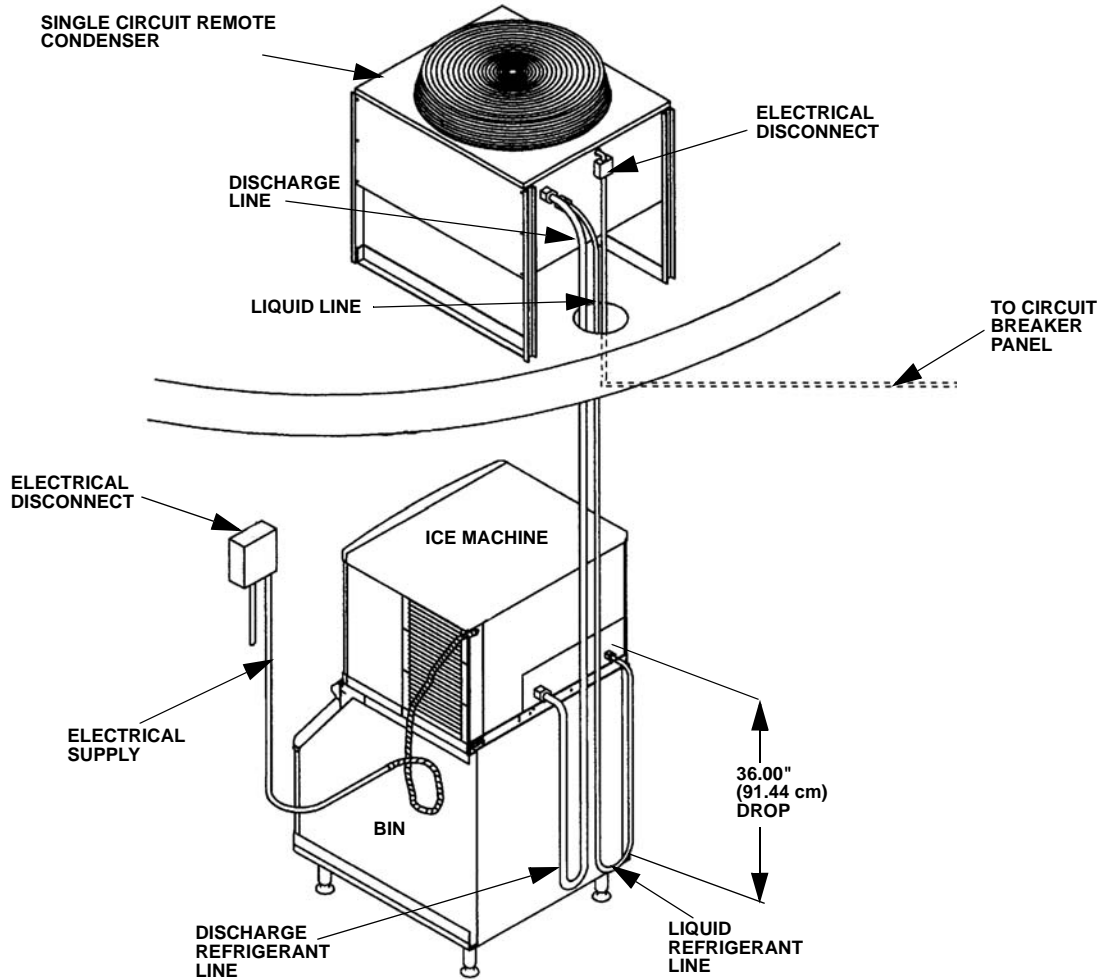

SV1615

Typical Single Circuit Traditional Remote Condenser Installation

**Refrigeration System Installation
Remote Condensing Unit Only**

QuietQube® Ice Machine	Remote Condensing Unit	Line Set*
SF900C SN950C	RFC985	RC-21 RC-31 RC-51
SF1200C SN1250C	RFC1285	RC-21 RC-31 RC-51

*Line Set	Suction Line	Liquid Line
RC 21/31/51	5/8 inch (15.9 mm)	3/8 inch (9.5 mm)

Important

Manitowoc remote systems are only approved and warranted as a complete new package. Warranty on the refrigeration system will be void if a new ice machine head section is connected to pre-existing (used) tubing or condensing units or vice versa.

**USAGE WITH NON-MANITOWOC
CONDENSING UNITS**

Manitowoc Remote Condensing Units are specifically designed for usage with a QuietQube® Ice Machine Head Section. Standard condensing units and Non-Manitowoc condensing units will not operate a QuietQube® Ice Machine Head Section.

⚠ Caution

The 60-month compressor warranty (including the 24-month labor replacement warranty) will not apply if the Manitowoc Ice Machine and Manitowoc Remote Condensing Unit are not installed according to specifications. This warranty also will not apply if the refrigeration system is modified with a condenser, heat reclaim device, or other parts or assemblies not manufactured by Manitowoc Ice, Inc.

Factory Equipment Refrigeration Amounts

ICE MACHINE HEAD SECTION

Each ice machine head section ships from the factory with a R-404A refrigerant charge appropriate for the entire system operation. The serial tag on the ice machine indicates the refrigerant charge. The refrigerant charge is sufficient to operate the ice machine in ambient temperatures between -20°F (-28.9°C) and 130°F (54.4°C). With line set lengths of up to 100 feet (30.5 m).

⚠ Warning

Potential Personal Injury Situation

The ice machine head section contains the refrigerant charge. Installation and brazing of the line sets must be performed by a properly trained and EPA certified refrigeration technician aware of the **dangers of dealing with refrigerant** charged equipment.

⚠ Caution

Never add more than nameplate charge to the refrigeration system for any application.

REMOTE CONDENSING UNIT

Each condensing unit ships from the factory pressurized with 50/50 nitrogen/helium mixture that must be removed during the installation process (approximately 20 psig).

REFRIGERATION LINE SETS/TRAP KIT

Refrigeration Rated Tubing and Trap Kits are shipped capped with atmospheric pressure.

⚠ Warning

Installation of a QuietQube® Condensing Unit may require the use of special equipment for placement. Trained and qualified personnel are required for proper rigging and lifting.

Refrigeration Line Set Installation Remote Condensing Unit Only

GENERAL

Refrigeration line set installations consist of vertical and horizontal line set distances between the ice machine and the condensing unit. The following guidelines, drawings and calculation methods must be followed to assure proper oil return and remote condensing unit/ice machine operation.

The refrigeration line set installer must be USA Government-Environmental Protection Agency (EPA) certified in proper refrigerant handling and servicing procedures.

Warning

The ice machine head section contains refrigerant charge. The ice machine head section contains three (3) refrigeration valves that **must remain closed** until proper installation of the line sets is completed.

Warning

Disconnect electrical power to the ice machine head section and remote condensing unit before proceeding.

Step 1 Verify Ice Machine and Remote Condensing Unit Locations Are Within Guidelines.

Prior to installation of the ice machine head section and remote condensing unit be sure that the distance between them is within the line set routing guidelines outlined in this manual.

Roof/Wall Penetration

If required, cut a 3-inch (76.2 mm) circular hole in the wall or roof for routing of refrigeration tubing. A qualified person must perform all roof penetrations.

Step 2 Route Refrigeration Tubing

Properly route refrigeration tubing between the ice machine head section and the remote condensing unit.

A. LINE SET LENGTH

100 feet (30.5 m) Length: The maximum measured length the line set can be.

The receiver is designed to hold a charge sufficient to operate the ice machine in ambient temperatures between -20°F (-28.9°C) and 130°F (54.4°C), with line set lengths of up to 100 feet (30.5 m). The maximum amount of lineset which can be exposed on the rooftop is 25% of the total length of the lineset.

Important

QuietQube® ice machines will not function with line sets greater than 100 feet (30.5 m). Do not attempt to go beyond this distance and add refrigerant charge to compensate!

B. LINE SET RISE OR DROP

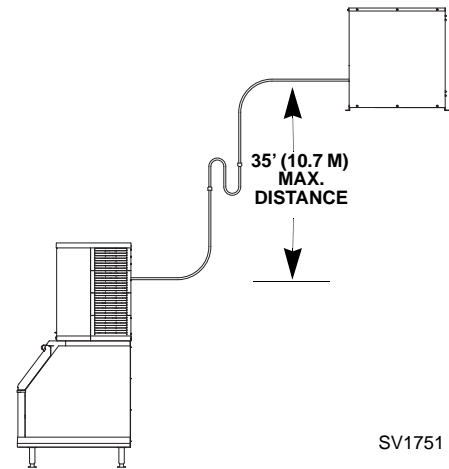

35 feet (10.7 m) Rise: The maximum distance the remote condensing unit can be above the ice machine.

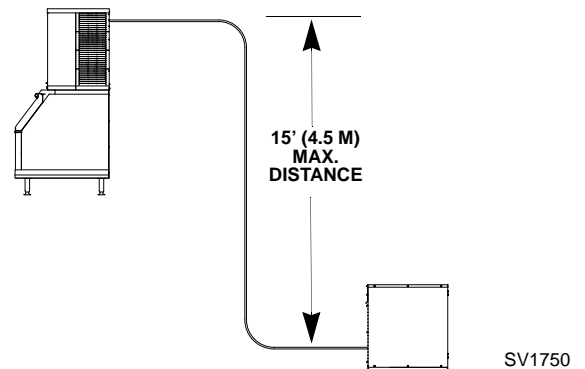

15 feet (4.5 m) Drop: The maximum distance the remote condensing unit can be below the ice machine.

C. SUCTION LINE OIL TRAPS

⚠ Caution

Do not form unwanted traps in refrigeration lines. Never coil excess refrigeration tubing.

0 to 20 feet (0 to 6.1 m) Rise: The ice machine head section has one oil trap built in which allows for a maximum condenser rise of 20 feet (6.1 m) without additional traps in the suction line.

21 to 35 feet (6.4 to 10.7 m) Rise: The suction line requires an additional Oil Trap (“S” type) to be installed. Install the trap as close as possible to midpoint between the ice machine head section and remote condensing unit. S-Trap Kits are available from Manitowoc (refer to chart).

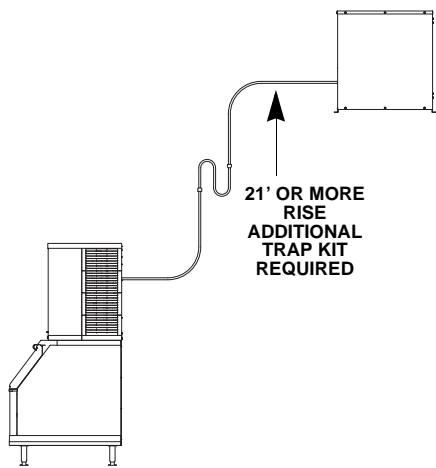

SV1751

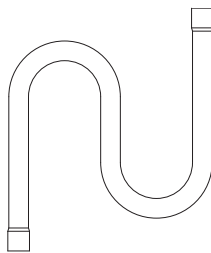

SV1760

Service Loop

A service loop in the line set permits easy access to the ice machine for cleaning and service.

- A service loop is not considered an oil trap.
- The service loop is not included when calculating length, rise or drop of the tubing run.
- Do not use hard rigid copper for the service loop.

⚠ Caution

If a line set has a rise followed by a drop, another rise cannot be made. Likewise, if a line set has a drop followed by a rise, another drop cannot be made.

Step 3 Lengthening or Reducing Line Set Lengths

⚠ Caution

Do not form unwanted traps in refrigeration lines. Never coil excess refrigeration tubing.

When the line set required shortening or lengthening, do so before connecting the line set to the ice machine head section or the remote condensing unit.

Step 4 Connecting the line set.

To prevent oxidation of the copper, purge line set and condensing unit with dry nitrogen while brazing.

Connect The Line Set To The Ice Machine Head Section

Warning

The ice machine head section contains refrigerant charge. The ice machine head section contains three (3) refrigeration valves that **must remain closed** until proper installation of the line sets is completed.

The line set shut off valves at the back of the ice machine must remain closed and be protected from heat during the brazing process. Wrap the valves in a wet rag or other type of heat sink prior to brazing. Cool braze joint with water immediately after brazing to prevent heat migration to the valve.

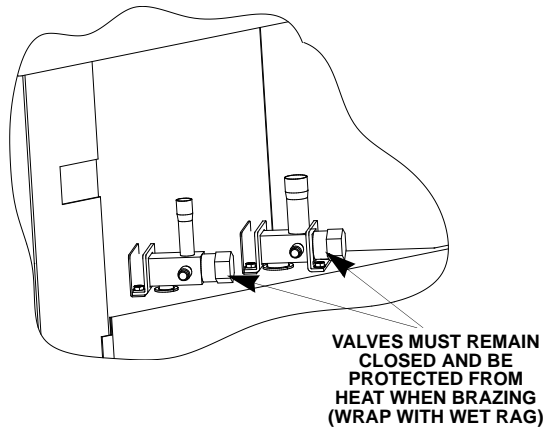

SV1757

Connect the Line Set to the Remote Condensing Unit

Warning

The condensing unit ships from the factory pressurized with a 50/50 mixture of nitrogen/helium. Bleed off pressure from both suction and liquid line access ports prior to cutting into refrigeration lines.

The compressor oil rapidly absorbs moisture. **Be prepared** to complete line set installation and start your evacuation process in order to minimize the time the compressor is exposed to the atmosphere. (Maximum amount of time the system can be exposed to the atmosphere is 15 minutes). The line set can be routed for entry through the front or left side of the condensing unit.

Remove knockout for (side entry only).

- Insert supplied plastic bushings in knockout holes to prevent tubing from contacting sheet metal.
- All entry locations use the supplied 90° elbows to route tubing.
- Cut the tubing ends of the suction and liquid lines and braze the line sets to the condensing unit.

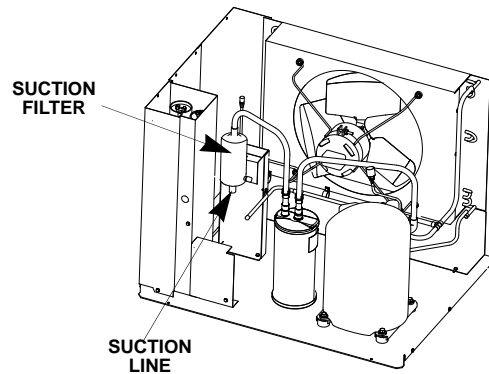

MINIMIZE THE TIME THE REFRIGERATION SYSTEM IS EXPOSED TO THE ATMOSPHERE (15 MINUTES MAXIMUM)

SV2085

Step 5 Pressure Test and Evacuate The Line Set and Remote Condensing Unit

Schrader valve core removal tools that allow for removal and installation of the valve cores without removing manifold gauge set hoses are recommended to decrease the evacuation time.

Leave the line set shut off valves closed (front seated). Pressure test the line sets and remote condensing unit with 150 psig of dry nitrogen. Add nitrogen at the line set shut off valves located at the back of the ice machine. Complete the pressure test, verify no leaks are present and remove the nitrogen from the system before connecting the vacuum pump. Connect a vacuum pump to both of the line set shut off valves located at the back of the ice machine head section. Evacuate to 250 microns (or less). To completely evacuate the remote condensing unit, continue the evacuation for 30 minutes after reaching the 500 micron point.

If required, the line set and condensing unit can be evacuated from the schrader valves located in the remote condensing unit. Schrader valve core removal tools (that allow for putting the cores back in without removing vacuum pump hoses) must be used if evacuating from the condensing unit side.

Isolate the vacuum pump from the line set shut off valves and/or condensing unit access ports prior to proceeding. Open refrigeration system shut off valves.

The suction line, liquid line and receiver service valves are closed during shipment and installation.

ALTERNATE CONNECTIONS AT CONDENSING UNIT SCHRADER VALVES

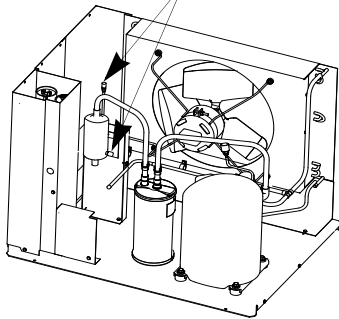

SV2085

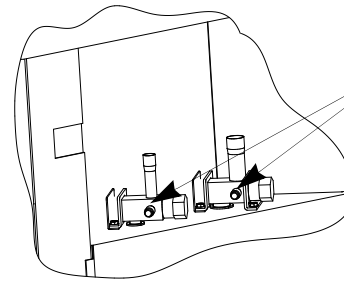

CONNECT VACUUM PUMP TO LINE SET SHUT OFF VALVES

SV1757

Step 6 Open The Valves Prior To Starting The Ice Machine.

- A. Slowly backseat (open-turn counterclockwise) the suction line shut off valve.
- B. Slowly backseat (open-turn counterclockwise) the liquid line shut off valve.
- C. Slowly backseat (open-turn counterclockwise) the receiver service valve.

NOTE: You will not hear refrigerant flow when the valves are opened. Refrigerant will not flow until the toggle switch is placed in the ice position and the solenoid valve opens.

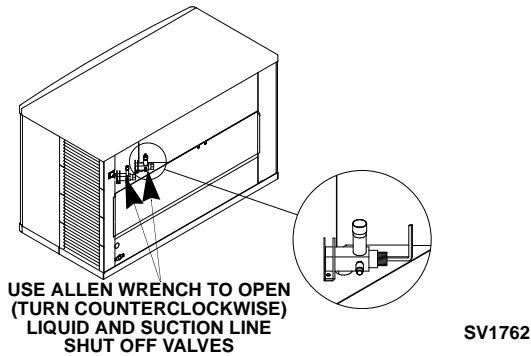

OPEN SUCTION AND LIQUID LINE SHUT OFF VALVES

Caution

After opening suction, discharge and receiver service valves, refrigerant pressure will not be detected until the toggle switch is placed in the ice position and the liquid line solenoid valve energizes.

Important

All refrigeration valve caps must be reinstalled to prevent future refrigeration leaks.

Verify O-ring in schrader valve caps are intact and reinstall on shut off valves to prevent refrigerant leakage. Replace shut off valve access caps and torque to the following specifications.

Torque Value's

Stem	18-20 ft. lbs.
Caps	12-15 ft. lbs.
Schrader Core	1.5-3 in. lbs.

Replace cap on receiver service valve and tighten.

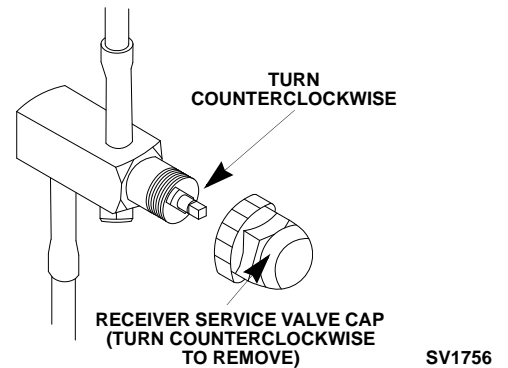

Open Receiver Service Valve

There is a liquid line solenoid valve at the outlet of the receiver; refrigerant will not flow to the condensing unit until the ice machine head section is started. Connect power to both the ice machine head section and the remote condensing unit. Place the ICE/OFF/CLEAN toggle switch into the ICE position, this will allow refrigerant to enter the line set and condensing unit.

Step 7 Leak Check The Refrigeration System

Leak check the new line set connections at the ice machine head section, condensing unit and S trap as well as all factory joints throughout the entire system. Disconnect power to the remote condensing unit. Place the ICE/OFF/CLEAN toggle switch into the ICE position. This allows the low side and high side pressures to equalize. Place the ICE/OFF/CLEAN toggle switch in the OFF position. Connect power to the remote condensing unit and allow system to pump down.

Step 8 Insulation Requirements

To prevent condensation the entire suction line including the shut-off valve must be insulated. All insulation must be airtight and sealed at both ends.

The following insulation requirements prevent condensation at 90°F (32.2°C) ambient 90% Relative Humidity. If higher humidity is expected, increase insulation thickness.

The entire suction line set, including the suction service valve located on the back of the ice machine requires:

Suction Line	Liquid Line	Min. Insulation Thickness
1/4" (7 mm)	5/16" (8 mm)	3/4" (19mm) Suction Line 1/4" (7mm) Liquid Line

Important

To prevent condensation the entire suction line including the shut off valve must be insulated. All insulation must be airtight and sealed at both ends. The minimum requirements are for conditions at or below 90% humidity and 90°F (32°C) ambient. When higher humidity will be experienced, or local code requires, insulation wall thickness will need to be increased.

Suction Shut Off Valve Insulation

The pre-formed suction shut-off valve insulation is located in the plastic bag taped to the water curtain.

- A. Verify valve and schrader caps are tightened to specifications (see Step 6).

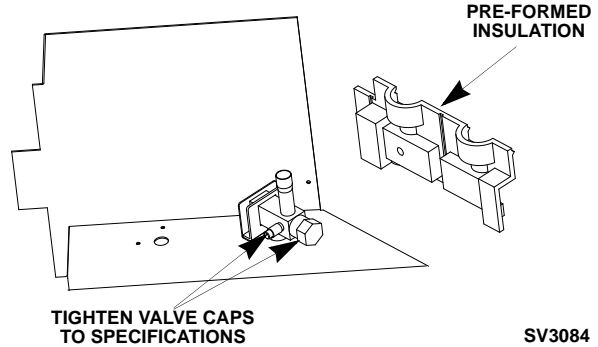

- B. Place insulation over schrader valve cap and left side of valve. Position the tab between the mounting bracket and rear panel.

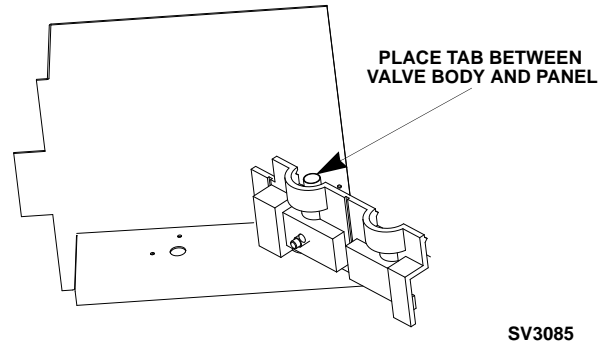

- C. Fold insulation and hold against right hand side of valve while securing with electrical tape. Seal the line set insulation to the shut off valve insulation with electrical tape.

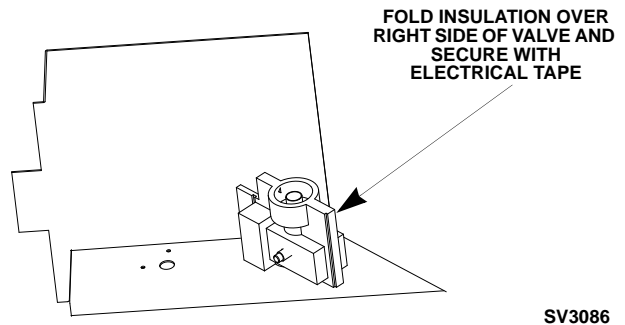

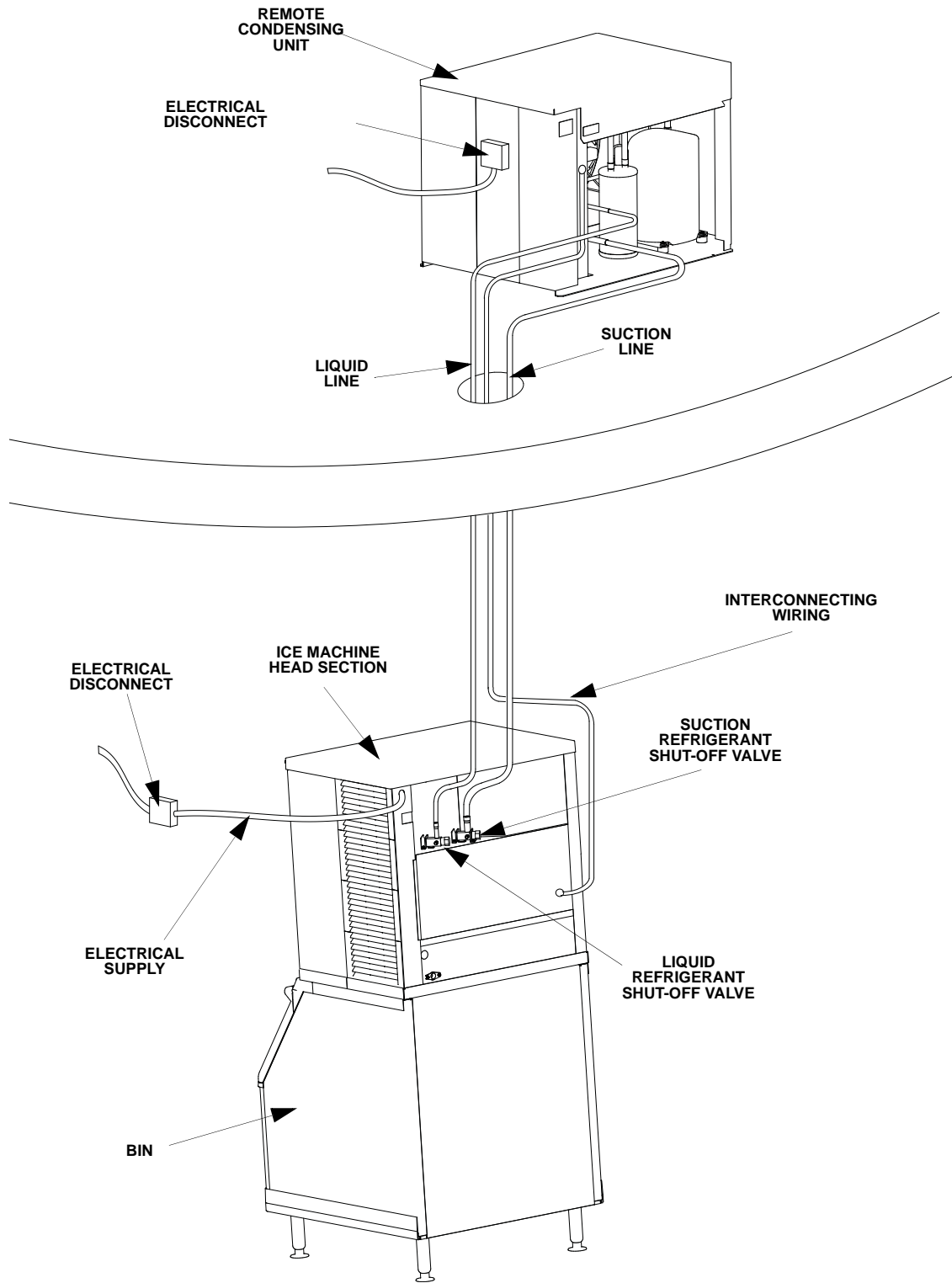

SV1759

Typical QuietQube System Installation

Installation Check List

All Manitowoc ice machines are factory-operated and adjusted before shipment. Adjustments and maintenance procedures outlined in this manual are the responsibility of the owner/operator and are not covered by the warranty.

- | | |
|------------------------------------------------------------------------------------------------------------------------------------------------------|---------------------------------------------------------------------------------------------------------------------------------------|
| <input type="checkbox"/> Is the Ice Machine level? | <input type="checkbox"/> Is the ice machine and drains seperately vented? |
| <input type="checkbox"/> Is the ice machine and adapter (when used) secured to the dispenser? | <input type="checkbox"/> Are all electrical leads free from contact with refrigeration lines and moving equipment? |
| <input type="checkbox"/> Have all of the electrical and water connections been made? | <input type="checkbox"/> Has the owner/operator been instructed regarding maintenance and the use of Manitowoc Cleaner and Sanitizer? |
| <input type="checkbox"/> Has the supply voltage been tested and checked against the rating on the nameplate? | <input type="checkbox"/> Has the owner/operator completed the warranty registration card? |
| <input type="checkbox"/> Is there proper clearance around the ice machine for air circulation? | <input type="checkbox"/> Has the ice machine and bin been sanitized? |
| <input type="checkbox"/> Is the ice machine grounded and polarity correct? | <input type="checkbox"/> Is the toggle switch set to ice? (The toggle switch is located behind the front panel). |
| <input type="checkbox"/> Has the ice machine been installed where ambient temperatures will remain in the range of 45° - 110°F (7° - 43°C)? | |
| <input type="checkbox"/> Has the ice machine been installed where the incoming water temperature will remain in the range of 45° - 90°F (7° - 32°C)? | |
| <input type="checkbox"/> Is there a separate drain for the water-cooled condenser? | |
| <input type="checkbox"/> Is there a separate drain for the dispenser? | |
| <input type="checkbox"/> Is the water reservoir approximately 2/3 full? | |

Additional Checks for Remote Models

- Is the lineset length, rise and drop within the guidelines?
- Has the receiver service valve been opened?
- Has the traditional remote condenser been located where ambient temperatures will remain in the range of -20° - 120°F (-29 - 49°C).
- Is the line set routed properly?
- Are both refrigeration lines to remote condenser run so they do not lay in water and are properly insulated?
- Has the ice machine receiver service valve been opened?
- Does the condenser fan motor(s) operate properly after start-up?
- Have all the refrigeration fittings and joints been leak checked?
- Is the line set routed properly?
- Has the condenser/condensing unit been installed to prevent any roofing damage?
- Have the refrigeration lines been insulated and secured properly to prevent vibration?
- Has the RFC remote condensing unit been located where ambient temperatures will remain in the range of -20° to 130°F (-29° to 54.4°C)?
- Are the plastic bushings installed on the RFC® condensing unit to prevent refrigeration tubing from contacting the sheet metal panel?
- Is a refrigeration oil trap (S-trap, QuietQube Only) installed if the condenser is installed 21 to 35 feet (6 to 11m) above the ice machine head?

THIS PAGE INTENTIONALLY LEFT BLANK

Section 3 Operation

Component Identification ICE MACHINE HEAD SECTION

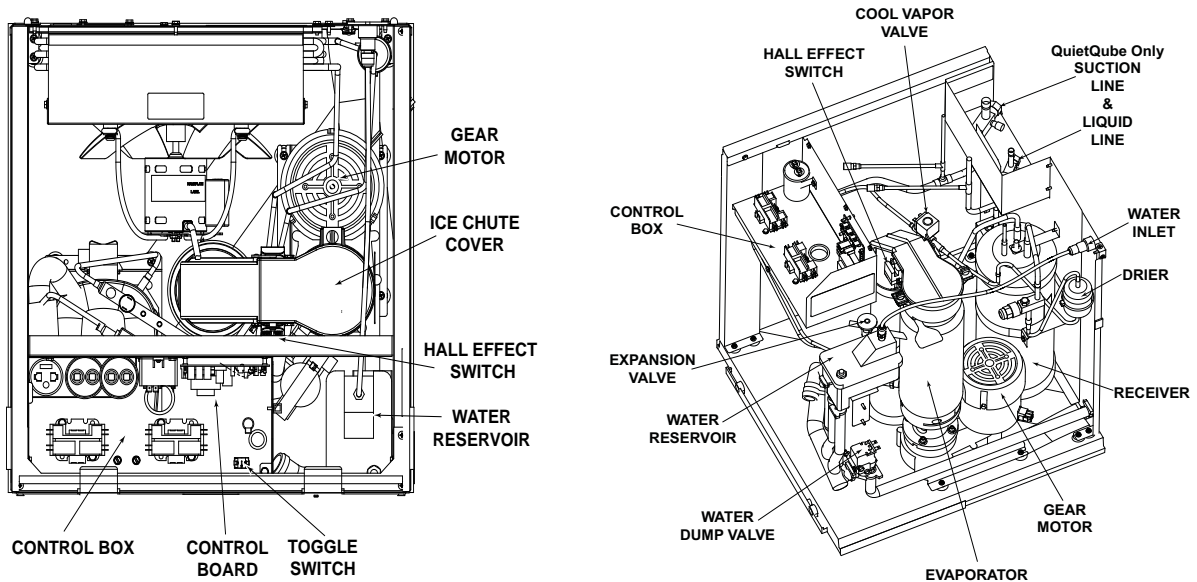
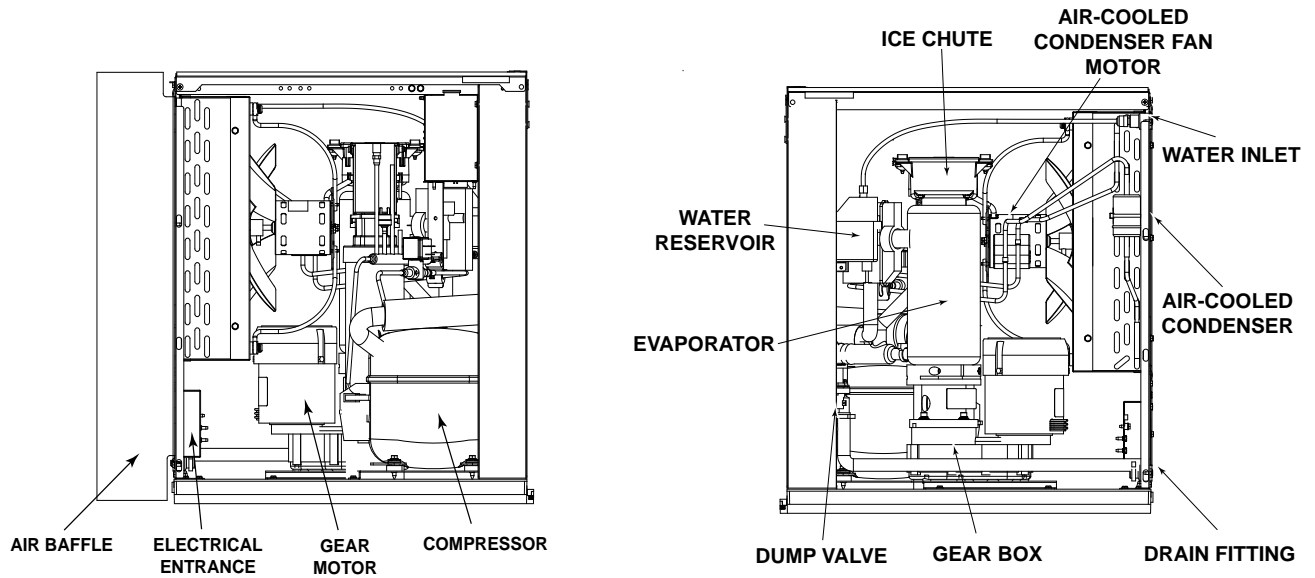

Remote & QuietCube Models

Operational Checks

GENERAL

Manitowoc ice machines are factory-operated and adjusted before shipment. Normally, a newly installed ice machine does not require any adjustment.

To ensure proper operation, always follow the Operational Checks:

- when starting the ice machine for the first time
- after a prolonged out of service period
- after cleaning and sanitizing

NOTE: Routine adjustments and maintenance procedures outlined in this manual are not covered by the warranty.

Toggle Switch

The toggle switch must be placed in the ON position to make ice.

Water Reservoir

The water reservoir must be 2/3 full of water and the water sensing float must be up (switch closed) before the ice machine will start.

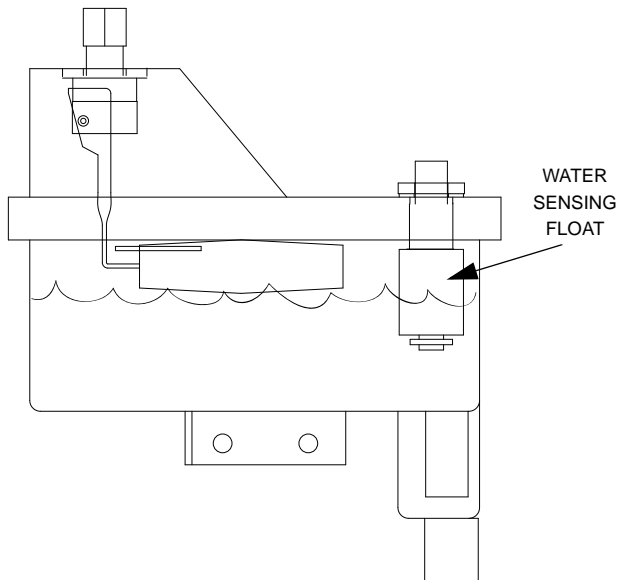

Warning

Potential Personal Injury Situation

Do not operate equipment that has been misused, abused, neglected, damaged, or altered/modified from that of original manufactured specifications.

Sequence of Operation

PRIOR TO STARTUP

When the toggle switch is placed in the ICE position the following must occur in the listed order before ice making will start.

- The 5 minute delay period must be expired. The delay period starts upon application of power.
- The ice chute damper must be in the closed or down position.
- The water sensing switch must be closed (water reservoir full of water and water sensing float in the up position).

1. Initial Startup - The ice machine is plugged in and the toggle switch is moved to ice.

A 5 minute delay period must expire. The delay period starts to time out upon application of power and can not be overridden. When the five minute delay period expires, the gear motor energizes. The water in the reservoir closes the water sensing (float) switch and the compressor and condenser fan motor energize.

2. Freeze Cycle

The float valve automatically maintains the water level in the reservoir. The ice damper will open and close to verify ice production. The ice machine will continue to make ice until the ice damper is held open (up) as ice fills the bin.

3. Automatic Shutoff

When the ice damper is held open by ice, the gearmotor, compressor and condenser fan de-energize. The five minute delay period starts to time out. The ice machine will remain off until the 5 minute delay period expires and the ice damper closes.

RESTART AFTER AUTOMATIC SHUTOFF

The 5 minute delay period must be expired. The delay period starts when the ice machine enters Automatic Shutoff and can not be overridden.

1. The ice machine was off for less than 30 minutes.

When the five minute delay period expires the gear motor, compressor and condenser fan motor energize.

2. The ice machine was off for more than 30 minutes.

The gear motor and dump valve energize to drain the water from the evaporator and reservoir. After 30 seconds the dump valve de-energizes. When the reservoir fills with water, the water sensing switch closes and the compressor and condenser fan motor energize.

CHANGING TOGGLE SWITCH POSITION IN THE FREEZE CYCLE

Moving the toggle switch from ICE to OFF will start a 5 minute delay period.

- Moving the toggle switch immediately to the ICE position - The ice machine waits 5 minutes, then initiates a Restart After Automatic Shutoff cycle.
- Moving the toggle switch to the ICE position after 5 minutes have elapsed - The ice machine immediately initiates a Restart After Automatic Shutoff cycle.

Control Board Features

FLUSH CYCLE

After the ice machine has completed 50 hours of run time a flush sequence will start. This cycle will drain and refill the evaporator to remove minerals that have settled to the bottom of the evaporator. The flush sequence lasts approximately 21 minutes, after which the ice machine will reset the 50 hour counter and automatically start ice making again.

POWER INTERRUPTION DELAY

If power is disconnected the ice machine stops. When power is reapplied a 5 minute delay is initiated.

SafeGuards

The ice machine control board has safety features to protect the ice machine from severe failures. The ice machine will stop when conditions arise that would cause major component failure. Refer to section 5 for details.

Section 4

Maintenance

Cleaning and Sanitizing

GENERAL

You are responsible for maintaining the ice machine in accordance with the instructions in this manual. Maintenance procedures are not covered by the warranty.

Clean and sanitize the ice machine every six months for efficient operation. If the ice machine requires more frequent cleaning and sanitizing, consult a qualified service company to test the water quality and recommend appropriate water treatment. An extremely dirty ice machine must be taken apart for cleaning and sanitizing.

Manitowoc Ice Machine Cleaner and Sanitizer are the only products approved for use in Manitowoc ice machines.

EXTERIOR CLEANING

Clean the area around the ice machine as often as necessary to maintain cleanliness and efficient operation. Use cleaners designed for use with stainless steel products.

Sponge any dust and dirt off the outside of the ice machine with mild soap and water. Wipe dry with a clean, soft cloth.

Heavy stains should be removed with stainless steel wool. Never use plain steel wool or abrasive pads. They will scratch the panels.

 **Caution**

Use only Manitowoc approved Ice Machine Cleaner (part number 000000084) and Sanitizer (part number 94-0565-3). It is a violation of Federal law to use these solutions in a manner inconsistent with their labeling. Read and understand all labels printed on bottles before use.

 **Caution**

Do not mix Cleaner and Sanitizer solutions together. It is a violation of Federal law to use these solutions in a manner inconsistent with their labeling.

 **Warning**

Wear rubber gloves and safety goggles (and/or face shield) when handling ice machine Cleaner or Sanitizer.

Manitowoc's Cleaning Technology

Manitowoc Flake/Nugget Ice Machines include technology that allows the initiation and completion of a cleaning cycle at the flip of a switch. This cycle will permit cleaning of all surfaces that come in contact with the water distribution system. Periodic maintenance must be performed that includes sanitizing the bin and adjacent surface areas, which are not contacted by the water distribution system.

Depending on local water conditions Manitowoc recommends initiating preventative maintenance cleaning procedures between the 6 month cleanings. This preventive maintenance removes mineral build-up from the evaporator, which results in peak efficiency and lower operating costs.

This technology allows initiation and completion of a clean cycle, after which the ice machine automatically starts ice making again.

This Manitowoc Ice Machine has three separate cleaning procedures.

Preventative Maintenance Cleaning Procedure

Perform this procedure as required for your water conditions. Recommended monthly.

- Allows cleaning the ice machine without removing all of the ice from the bin
- Removes mineral deposits from areas or surfaces that are in direct contact with water during the freeze cycle (reservoir, evaporator, auger, drain lines).

Cleaning/Sanitizing Procedure

This procedure must be performed a minimum of once every six months.

- All ice must be removed from the bin
- The ice machine and bin must be disassembled cleaned and sanitized
- The ice machine produces ice with the cleaner and sanitizer solutions
- All ice produced during the cleaning and sanitizing procedures must be discarded

Heavily Scaled Cleaning Procedure

Perform this procedure if you have some or all of these symptoms.

- Grinding, popping or squealing noises from the evaporator
- Grinding noise from gearbox
- Ice machine stops on Safety Shutdown
- Your water has a high concentration of minerals
- The ice machine has not been on a regular maintenance schedule.

Run a cleaning procedure as described above after this procedure is complete.

PREVENTATIVE MAINTENANCE CLEANING PROCEDURE

Ice machine cleaner is used to remove lime scale or other mineral deposits. It is not used to remove algae or slime. Refer to "Sanitizing Procedure" for removal of algae and slime. To initiate a cleaning cycle using Manitowoc's Cleaning Technology use the following procedure.

Step 1 To start a cleaning cycle, move the toggle switch to the CLEAN position. Water will flow through the water dump valve and down the drain.

Step 2 Remove the cover from the top of the ice chute. Wait about one minute then add the proper amount of Manitowoc Ice Machine Cleaner. Rinse the cleaner from the top of the evaporator with 2 ounces (60 ml) of clear water and re-install cover..

⚠ Caution

Use only Manitowoc approved Ice Machine Cleaner part number 000000084. It is a violation of Federal law to use these solutions in a manner inconsistent with their labeling. Read and understand all labels printed on bottles before use.

Model	Amount of Cleaner Part Number 000000084
SF0400 SN0450	2 ounce (60 ml)
SF0600 SN0650	3 ounces (90 ml)
SF0900 SN0950	6 ounces (180 ml)
SF1200 SN1250	8 ounces (240 ml)

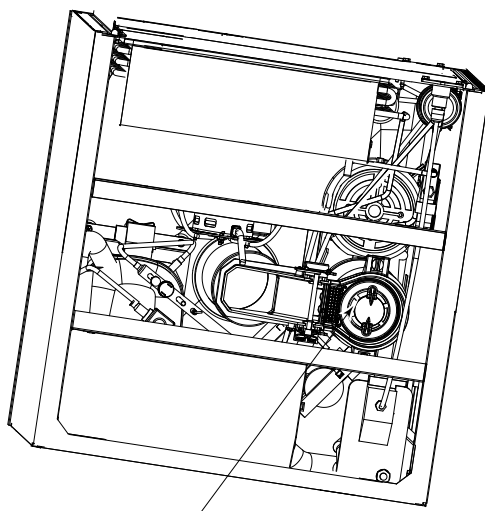

ADD SOLUTION HERE

Step 3 The ice machine will run a wash cycle, a series of rinse cycles and then stop. This entire cycle lasts approximately 30 minutes.

NOTE: Periodic cleaning must be performed on adjacent surface areas not contacted by the water distribution system.

NOTE: The ice machine may be set to start and finish a cleaning procedure, and then automatically start ice making again.

- A. After cleaner is added move the switch from CLEAN to ICE position.
- B. When the cleaning cycle is complete ice making will start automatically.

Changing toggle switch position during clean cycle:

1. Less than 60 seconds into Clean cycle - The Clean cycle will end when the toggle switch is moved to the OFF position.
 2. More than 60 seconds into Clean cycle - The ice machine will complete the clean cycle. Toggle switch position will determine the next cycle after the Clean cycle is completed.
- **CLEAN POSITION** - The ice machine will wait for a change in toggle switch position.
 - **OFF POSITION** - The ice machine will wait for a change in toggle switch position.
 - **ICE POSITION** - The ice machine will start making ice automatically.

Manitowoc recommends disassembling, cleaning and sanitizing the ice machine and dispenser every six months.

PROCEDURE TO CLEAN HEAVILY SCALED FLAKE/NUGGET ICE MACHINES

Ice machines that are heavily scaled or have not been cleaned on a regular basis will need to run this Procedure. Failure to do so may result in binding of the auger as the lime scale releases from the auger and evaporator barrel.

Step 1 Remove panels and set the ICE/OFF/CLEAN toggle switch to the OFF position.

Step 2 Remove all ice from the bin.

Step 3 Turn off the water supply to the ice machine.

Step 4 Place ICE/OFF/CLEAN toggle switch in the CLEAN position. The dump valve will open and drain the water from the evaporator and reservoir.

Step 5 Wait approximately 30 seconds (or until the evaporator is drained) and place the toggle switch in the OFF position.

Step 6 Refer to chart and add the correct amount of cleaner for your model ice machine.

Model	Amount of Cleaner Part Number 000000084
SF0400 SN0450	12 ounces (355 ml)
SF0600 SN0650	12 ounces (355 ml)
SF0900 SN0950	12 ounces (355 ml)
SF1200 SN1250	24 ounces (710 ml)

Step 7 Turn on the water supply to the ice machine.

Important

Leave the cleaner/water solution in the evaporator for a minimum of 4 hours.

Step 8 Move the toggle switch to the ICE position. The compressor will energize and produce ice with the cleaning solution. Continue the freeze cycle for 15 minutes.

Step 9 Move the toggle switch to the OFF position, then follow the standard cleaning and sanitizing procedures (Pages 4-5 & 4-6).

CLEANING PROCEDURE

Ice machines that are heavily scaled or have not been cleaned on a regular basis will need to run the Heavily Scaled Cleaning Procedure before this one. Failure to do so may result in binding of the auger as the lime scale releases from the auger and evaporator barrel.

Ice machine cleaner is used to remove lime scale or other mineral deposits. It is not used to remove algae or slime. Refer to the "Sanitizing Procedure" for removal of algae and slime.

Step 1 Remove panels and set the ICE/OFF/CLEAN toggle switch to the OFF position

Step 2 Turn off the water supply to the ice machine.

Step 3 Remove all ice from the bin.

Step 4 Place ICE/OFF/CLEAN toggle switch in the CLEAN position. The dump valve will open and drain the water from the evaporator and reservoir.

Step 5 Wait approximately 30 seconds (or until the evaporator is drained) and place the toggle switch in the OFF position.

Step 6 Refer to chart and premix the correct solution of cleaner and cool water for your model ice machine.

Model	Amount of Cleaner Part Number 000000084	Amount of Water
SF0400 SN0450	2 ounces (60 ml)	32 ounces (1 liter)
SF0600 SN0650	3 ounces (90 ml)	32 ounces (1 liter)
SF0900 SN0950	4 ounces (120 ml)	32 ounces (1 liter)
SF1200 SN1250	8 ounces (235 ml)	64 ounces (2 liter)

 **Caution**

Use only Manitowoc approved Ice Machine Cleaner part number 000000084. It is a violation of Federal law to use these solutions in a manner inconsistent with their labeling. Read and understand all labels printed on bottles before use.

Step 7 Remove the top cover from the ice chute and pour the cleaner/water solution into the evaporator. Add the entire amount of premixed solution (excess solution will exit through the overflow tube in the water reservoir).

Step 8 Replace the ice chute cover and allow the ice machine to stand for 30 minutes.

Step 9 Turn on the water supply to the ice machine.

Step 10 Move the toggle switch to the ICE position. The compressor will energize and produce ice with the cleaning solution.

Step 11 The ice machine will freeze and discharge the cleaning solution into the bin. Allow the cycle to run for 15 minutes.

Step 12 Place the toggle switch in the OFF position and refer to sanitizing procedure.

NOTE: Discard all ice produced during the cleaning process. Cleaning and sanitizing must be performed on adjacent surface areas not contacted by the water distribution system. Refer to Removal of Parts for Cleaning/Sanitizing (Page 4-7) - Disassemble, clean and sanitize the ice machine a minimum of once every six months.

SANITIZING PROCEDURE

Ice machine sanitizer is used to remove algae or slime. It is not used to remove lime scale or other mineral deposits. Refer to the “Cleaning Procedure” for removal of lime scale or other mineral deposits.

NOTE: Sanitizing must be performed on adjacent surface areas not contacted by the water distribution system. Always perform Disassembly for Cleaning and Sanitizing Procedure and a Cleaning Procedure before sanitizing the ice machine.

Step 1 Turn off the water supply to the ice machine.

Step 2 Place ICE/OFF/CLEAN toggle switch in the CLEAN position. The dump valve will open and drain the water from the evaporator and reservoir.

Step 3 Wait approximately 30 seconds (or until the evaporator is drained) and place the toggle switch in the OFF position.

Step 4 Refer to chart and premix the correct solution of sanitizer and cool water for your model ice machine.

Model	Amount of Sanitizer Part Number 94-0565-3	Amount of Water
SF0400 SN0450	2 ounces (60 ml)	3 gallons (11.4L)
SF0600 SN0650		
SF0900 SN0950		
SF1200 SN1250		

Step 5 Remove the top cover from the ice chute and pour the sanitizer/water solution into the evaporator. Add the entire amount of premixed solution (excess solution will exit through the overflow tube in the water reservoir).

Step 6 Replace the ice chute cover and allow the ice machine to stand for 30 minutes.

Step 7 Turn on the water supply to the ice machine.

Step 8 Move the toggle switch to the ICE position. The compressor will energize and produce ice with the sanitizing solution.

Step 9 The ice machine will freeze and discharge the sanitizing solution into the bin. Allow the cycle to run for 15 minutes.

NOTE: Discard all ice produced during the sanitizing process.

Step 10 The ice machine will run a wash cycle, a series of rinse cycles and then stop. This entire cycle lasts approximately 30 minutes.

Step 11 Refer to Disassembly For Cleaning/Sanitizing, (Page 4-7) remove clean and sanitize all parts listed.

Component Disassembly For Cleaning And Sanitizing

The ice machine must be disassembled cleaned and sanitized every six months.

Warning

Wear rubber gloves and safety goggles (and/or face shield) when handling Ice Machine Cleaner or Sanitizer.

1. Remove front, side and top panels.
2. Refer to pages 4-4, 4-5 and 4-6 and perform the cleaning and sanitizing procedures.
3. Run the ice machine in the freeze cycle for 5 minutes, then place the toggle switch in the OFF position.
4. Disconnect the main power supply to the ice machine.
5. Remove the ice chute cover.
 - A. Turn the two thumbscrews 1/4 turn
 - B. Lift to remove cover.

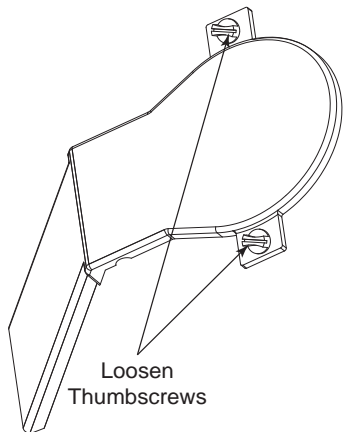

6. Turn ice wiper counterclockwise to remove.

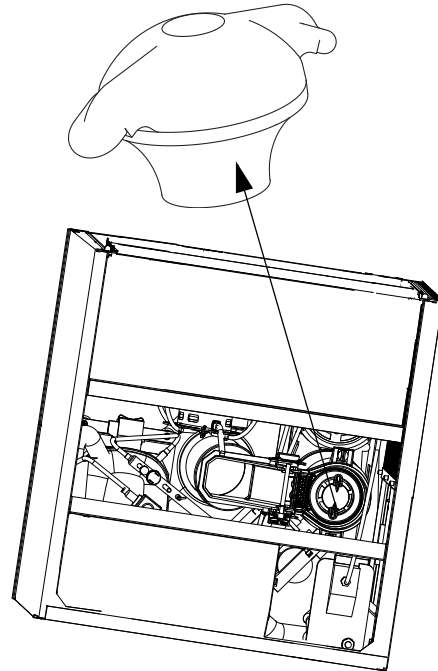

7. Disconnect the water supply.
8. Reconnect the main power supply to the ice machine.
9. Place toggle switch in the clean position for 30 seconds to drain water from reservoir, then move the toggle switch to the Off position.
10. Disconnect the main power supply to the ice machine..

Warning

Disconnect electric power to the ice machine at the electric switch box before proceeding.

11. Lift out ice damper.

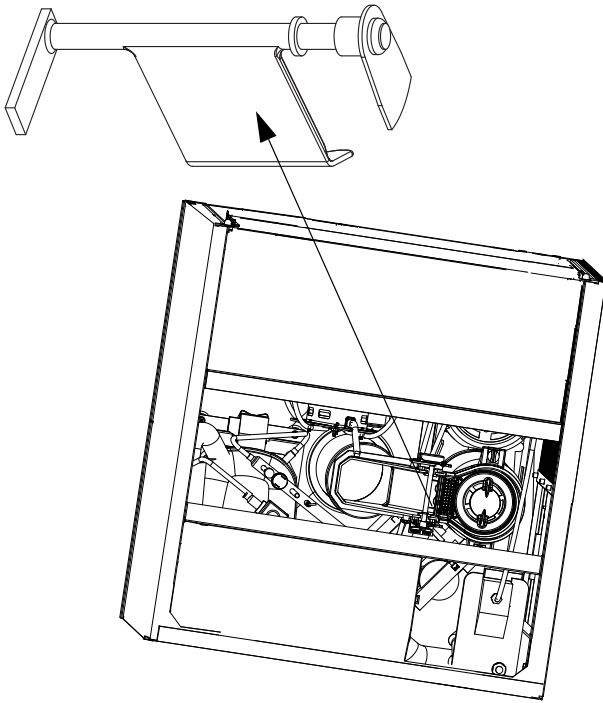

12. Lift out ice strainer ramp.

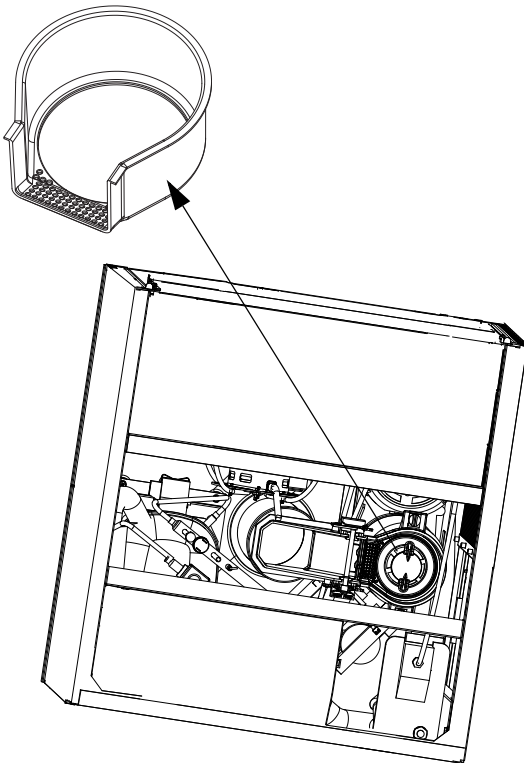

13. Loosen ice chute hose clamp.

14. Disconnect ice chute drain.

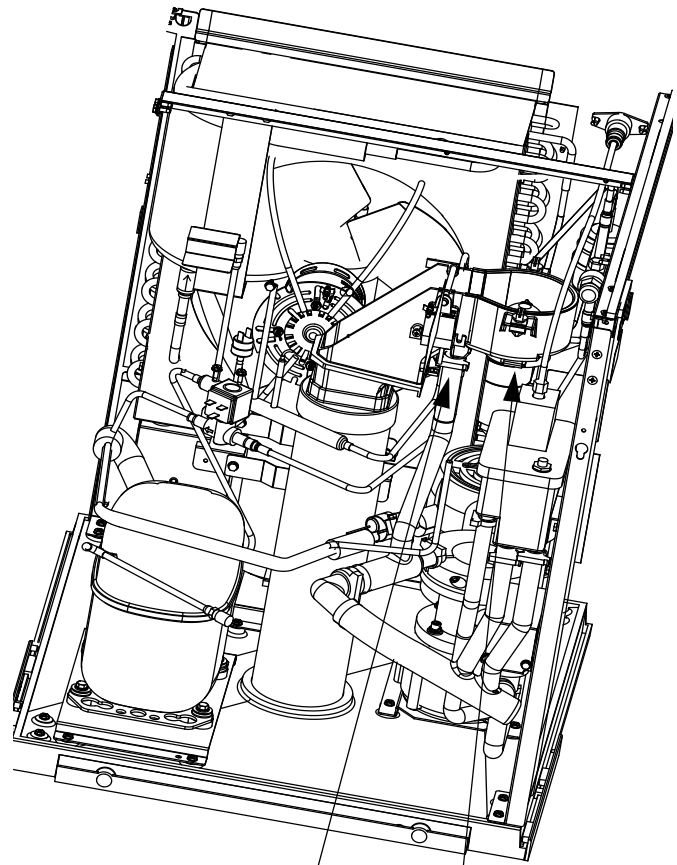

Ice Chute Drain and Hose Clamp

15. Lift up on ice chute to remove.

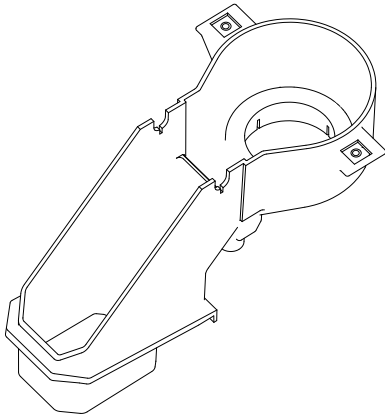

16. The ice chute can be cleaned in place. If complete removal is desired use a phillips screwdriver to remove the Hall Effect Switch assembly from the ice chute.

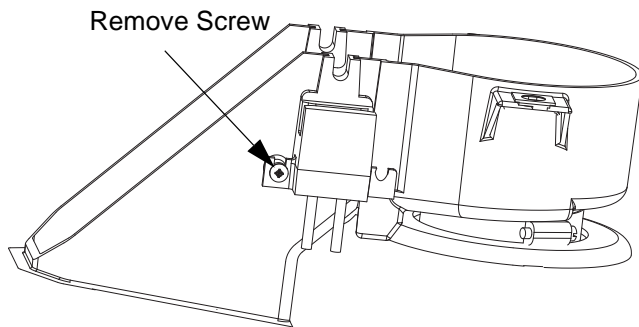

17. Remove ice chute collar and tube by lifting straight up..

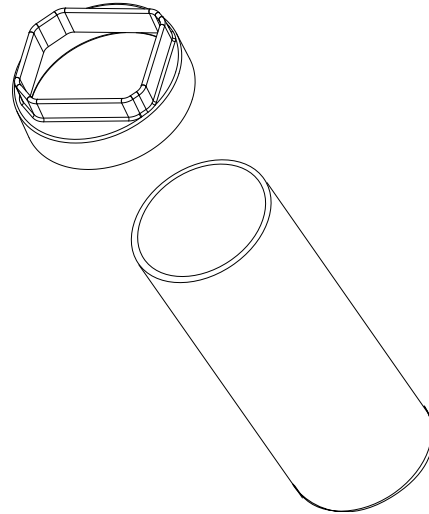

18. Remove water reservoir cover by pushing up on cover to snap off. The water reservoir can be cleaned in place.

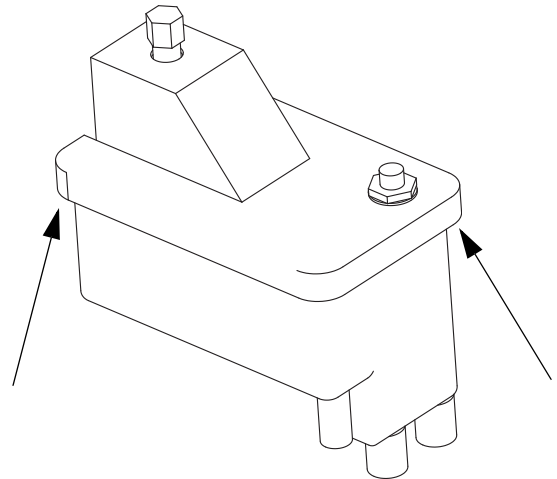

⚠ Caution

Do not mix Cleaner and Sanitizer solutions together. It is a violation of Federal law to use these solutions in a manner inconsistent with their labeling.

- 19. Mix a solution of cleaner and warm water. Depending upon the amount of mineral buildup, a larger quantity of solution may be required. Use the ratio in the table below to mix enough solution to thoroughly clean all parts.

Solution Type	Water	Mixed With
Cleaner	1 gal. (4 l)	16 oz (500 ml) cleaner

- 20. The cleaner solution will foam when it contacts lime scale and mineral deposits; once the foaming stops use a soft-bristle nylon brush, sponge or cloth (NOT a wire brush) to carefully clean the parts. Soak parts for 5 minutes (15 - 20 minutes for heavily scaled parts). Rinse all components with clean water.
- 21. While components are soaking clean all foodzone surfaces of the bin (or dispenser). Rinse all areas thoroughly with clean water.

- 22. .Mix a solution of sanitizer and warm water.

Solution Type	Water	Mixed With
Sanitizer	6 gal. (23 l)	4 oz (120 ml) sanitizer

- 23. Use 1/2 of the sanitizer/water solution to sanitize all removed components. Use a cloth or sponge to liberally apply the solution to all surfaces of the removed parts or soak the removed parts in the sanitizer/water solution. Do not rinse parts after sanitizing.
- 24. Use 1/2 of the sanitizer/water solution to sanitize the bin (or dispenser). Use a cloth or sponge to liberally apply the solution. Do not rinse the sanitized areas.
- 25. Reinstall the removed parts, restore water and power supply and test run the ice machine.

NOTE: Disconnecting the power supply will activate a 5 minute time delay before the ice machine will start. The delay will start to time out when power is restored to the ice machine. This delay period can not be over ridden.

Water Dump Valve

The water dump valve normally does not require removal for cleaning. To determine if removal is necessary:

1. Set the toggle switch to ICE.
2. Verify the water reservoir fills with water at the beginning of the freeze cycle.
3. While the ice machine is in the freeze cycle, check the drain line to determine if water is flowing to the drain:
 - A. Verify the water level in the reservoir is below the overflow (reservoir should be 2/3 full).
 - B. Remove, disassemble and clean the dump valve.
 - C. If the dump valve is not leaking, do not remove it. Instead, follow the "Ice Machine Cleaning Procedure".

Follow the procedure below to remove the dump valve.

Warning

Disconnect the electric power to the ice machine at the electric service switch box and turn off the water supply before proceeding.

1. Leaving the wires attached, twist coil and rotate it counter-clockwise 1/4 turn.
2. Lift the coil assembly off the valve body.
3. Remove the spring, plunger, and nylon gasket from the valve body.

NOTE: At this point, the water dump valve can easily be cleaned. If complete removal is desired, continue with step 4.

NOTE: During cleaning, do not stretch or damage the spring.

4. Remove the tubing from the dump valve by twisting the clamps off.

NOTE: Twist the valve body to remove from mounting bracket.

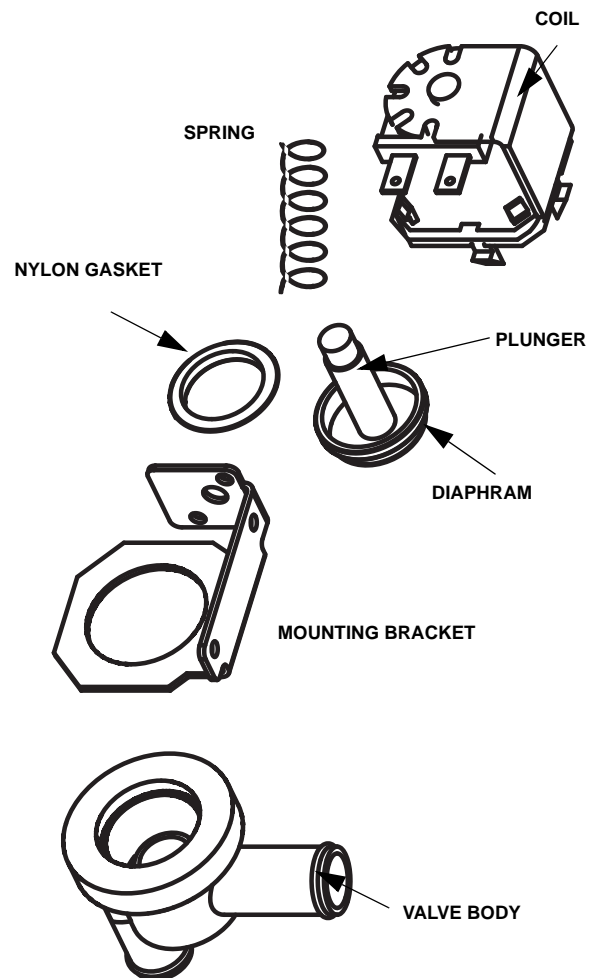

Dump Valve Disassembly

Cleaning the Condenser

 **Warning**

Disconnect electric power to the ice machine and the remote condenser at the electric service switch before cleaning the condenser.

Air-Cooled Condenser

(SELF-CONTAINED AND REMOTE MODELS)

A dirty condenser restricts airflow, resulting in excessively high operating temperatures. This reduces ice production and shortens component life. Clean the condenser at least every six months. Follow the steps below.

 **Caution**

The condenser fins are sharp. Use care when cleaning them.

1. The washable filter on self-contained ice machines is designed to catch dust, dirt, lint and grease. This helps keep the condenser clean. Clean the filter with a mild soap and water solution.
2. Clean the outside of the condenser with a soft brush or a vacuum with a brush attachment. Clean from top to bottom, not side to side. Be careful not to bend the condenser fins.
3. Shine a flashlight through the condenser to check for dirt between the fins. If dirt remains:
 - A. Blow compressed air through the condenser fins from the inside. Be careful not to bend the fan blades.
 - B. Use a commercial condenser coil cleaner. Follow the directions and cautions supplied with the cleaner.
4. Carefully wipe off the fan blades and motor with a soft cloth. Do not bend the fan blades. If the fan blades are excessively dirty, wash with warm, soapy water and rinse thoroughly.

 **Caution**

If you are cleaning the condenser fan blades with water, cover the fan motor to prevent water damage.

Water-Cooled Condenser and Water Regulating Valve

Symptoms of restrictions in the condenser water circuit include:

- Low ice production
- High water consumption
- High operating temperatures
- High operating pressures

If the ice machine is experiencing any of these symptoms, the water-cooled condenser and water regulating valve may require cleaning due to scale build-up.

Because the cleaning procedures require special pumps and cleaning solutions, qualified maintenance or service personnel must perform them.

Removal from Service/Winterization

GENERAL

Special precautions must be taken if the ice machine head section is to be removed from service for an extended period of time or exposed to ambient temperatures of 32°F (0°C) or below.

Caution

If water is allowed to remain in the ice machine in freezing temperatures, severe damage to some components could result. Damage of this nature is not covered by the warranty.

Follow the applicable procedure below.

Self-Contained Air-Cooled Ice Machines

1. Disconnect the electrical power at the circuit breaker or the electric service switch.
2. Turn off the water supply.
3. Disconnect and drain the incoming ice-making water line at the rear of the ice machine.
4. Disconnect drain tubing (from the inlet to dump valve) and drain water into container and discard.
5. Make sure water is not trapped in any of the water lines, drain lines, distribution tubes, etc.

Remote Air-Cooled Ice Machines

1. Move the ICE/OFF/CLEAN switch to OFF.
2. "Frontseat" (shut off) the receiver service valves. Hang a tag on the switch as a reminder to open the valves before restarting.
3. Perform steps 1-5 under "Self-Contained Air-Cooled Ice Machines."

Self-Contained Water-Cooled Ice Machines

1. Perform steps 1-5 under "Self-Contained Air-Cooled Ice Machines."
2. Disconnect the incoming water and drain lines from the water-cooled condenser.
3. Insert a large screwdriver between the bottom spring coils of the water regulating valve. Pry upward to open the valve.

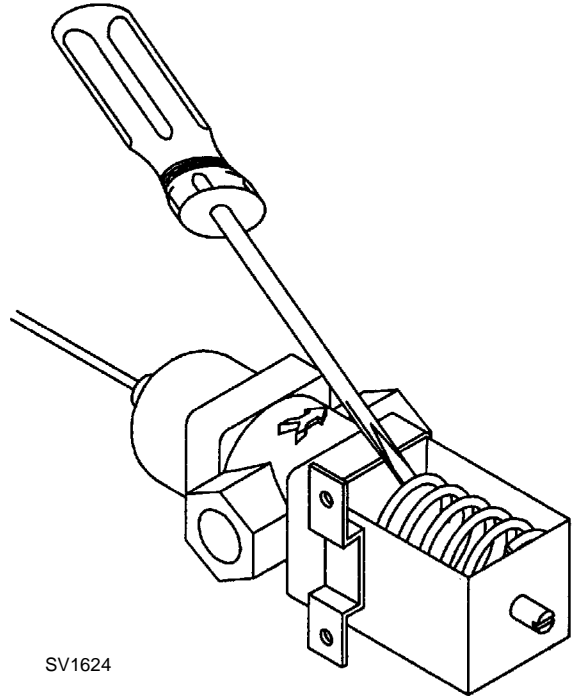

Pry Open the Water Regulating Valve

4. Hold the valve open and blow compressed air through the condenser until no water remains.

THIS PAGE INTENTIONALLY LEFT BLANK

Section 5

Before Calling for Service

Checklist

If a problem arises during operation of your ice machine, follow the checklist below before calling for service. Routine adjustments and maintenance procedures are not covered by the warranty.

Problem	Possible Cause	To Correct
Ice machine does not operate	No electrical power to the ice machine	Reset the breaker/turn on main power switch/ plug cord into receptacle
	ICE/OFF/CLEAN toggle switch set improperly	Move toggle switch to the ICE position
	Control Board fuse open	Replace the fuse
	5 minute delay has not expired	Wait 5 minutes for ice machine to start
	High Pressure Control is open	Clean filter and condenser
Gear Motor runs but compressor will not start / no ice is made.	Water reservoir is empty. (Water sensing switch must be closed to start the compressor)	Open water service valve or clean float valve screen
Ice machine stops and can be restarted by moving the toggle switch to OFF and back to ICE	The SafeGuard feature is stopping the ice machine	Refer to "SafeGuard Feature" in this section
Ice quality is poor	Poor incoming water quality	Contact a qualified service company to test the quality of the incoming water and check filter
	Water filtration is poor	Replace filter
	Incoming water temperature is above 90°F (32.3°C)	Correct water temperature. (Verify check/mixing valves in other equipment are working properly). Connect the ice machine to a cold water supply
	Water pressure is low	Water pressure must remain between 20 and 80 psig
	Water softener is working improperly (if applicable)	Repair the water softener
Low ice capacity or Ice machine turns Off & On repeatedly	Water float valve screen is dirty	Remove and clean the filter screen
	Incoming water supply is shut-off	Open the water service valve
	Water dump valve is leaking	Clean the dump valve
	Water Pressure is low. The water sensing switch turns off the ice machine repeatedly	Water pressure must remain between 20 and 80 psig
	Incoming water temperature is above 90°F (32.2°C)	Correct water temperature. (verify check/mixing valves in other equipment is working properly)
	Frequent power interruptions or power surges/dips	Verify ice machine is on a separate circuit and power is stable
	Water float valve stuck open or leaking	Remove the float valve and clean it
	Air-Cooled Models Only Objects stacked around ice machine, blocking airflow to condenser	Remove items blocking airflow
	High air temperature around ice machine	Air temperature must not exceed 110°F (43.3°C)
	Inadequate clearance around the ice machine	Provide adequate clearance
	The condenser is dirty	Clean the condenser
	QuietQube Only Condensing unit fuse open or no electrical power to condensing unit.	Replace fuse/reset breaker/turn on main power switch.

Safeguard Feature

In addition to standard safety controls, your Manitowoc ice machine features built-in SafeGuards. The ice machine will stop when conditions arise that would cause major component failure.

GENERAL

The ice machine control board has safety features to protect the ice machine from severe failures. The ice machine will stop when conditions arise that would cause major component failure.

A control board light will flash to indicate which Safeguard has stopped the ice machine.

Safeguards can be viewed by placing the ICE/OFF/CLEAN toggle switch in the OFF position.

After 48 hours a Safeguard is automatically erased.

DETERMINING WHICH SAFEGUARD STOPPED THE ICE MACHINE

Move the ICE/OFF/CLEAN toggle switch to OFF.

If a safeguard has stopped the ice machine, the light which corresponds to the failure will flash.

SAFEGUARD INDICATOR LIGHTS

During a SafeGuard Mode the corresponding light will flash continuously.

Example; the "water ok" light on the control board flashes when the toggle switch is placed in the Off position. This indicates a loss of water in the reservoir or a failure of the water sensing switch.

The SafeGuard will remain in memory for 48 hours after the control is reset with the toggle switch. After 48 hours the SafeGuard will automatically be erased. If power is interrupted during the 48 hours, the timing will resume when power is applied to the ice machine.

Placing the toggle switch in the OFF position:

The corresponding light will flash continuously.

Placing the toggle switch in the ICE position:

The light will de-energize and a start-up sequence will initiate.

During the first 48 hours after the control board was reset, the corresponding light will flash anytime the toggle switch is placed in the OFF position.

SafeGuards

1. No Water - The water sensor switch opens for more than 20 seconds during the freeze cycle.
2. No Ice Production - The damper door (HES1) fails to open and close at least once during the first 8 minutes of compressor run time.

or

The damper door fails to open and close at least once every 90 seconds during the freeze cycle.

RESET PROCEDURE

1. Move the ICE/OFF/CLEAN toggle switch to OFF and then back to ICE.
 - A. If a safeguard feature has stopped the ice machine, it will restart after a short delay. Proceed to step 2.
 - B. If the ice machine does not restart, refer to "Ice Machine Does Not Operate" in section 5.
2. Allow the ice machine to run to determine if the problem still exists.
 - A. If the ice machine continues to run, the condition has corrected itself. Allow the ice machine to continue running.
 - B. If the ice machine stops again, the problem still exists.

SafeGuard Modes

NO WATER

During the Freeze cycle if the water sensing switch opens or remains open for more than 20 continuous seconds,

1. The ice machine will de-energize the compressor and gear motor immediately
2. Continuously flash the control board water OK light
3. Initiate a 5 minute Standby Mode

After the 5 minute standby the ice machine will check the status of the water level sensor.

WATER LEVEL SENSOR CLOSED:

The ice machine will initiate a startup sequence.

No Water SafeGuard Checklist

Possible Problem List	Corrective Action List
No water	Restore water supply.
Water float valve screen blocked	Clean screen.
Water float valve improperly adjusted	Adjust valve (see Water level check).
Dump valve leaking	Repair or replace dump valve.
Water sensing switch disconnected or removed	Connect or correctly position sensor
Float reservoir cover is removed	Install reservoir cover

WATER LEVEL SENSOR OPEN:

The ice machine will wait for the water level sensor to close.

INDICATOR LIGHT

Before 48 hours have elapsed:

After a Standby Mode has been initiated the water level light will flash anytime the toggle switch is placed in the OFF position.

After 48 hours have elapsed:

The SafeGuard will be automatically erased from memory and the water level will not flash.

NO ICE PRODUCTION

The damper door (HES1) fails to open and close at least once during the first 8 minutes of compressor run time

or

The damper door fails to open and close at least once every 90 seconds during the freeze cycle

1. The ice machine will de-energize the compressor and gear motor immediately
2. Continuously flash the HES1 control board light
3. Initiate a 60 minute Standby Mode

After the 60 minute standby the ice machine will restart.

ICE PRODUCTION NORMAL:

The ice machine will continue to run.

NO ICE PRODUCTION:

The ice machine will start another 60 minute Standby Mode.

When 5 consecutive 60 minute Standby Modes occur the ice machine shuts off and flashes the HES1 control board light. The ice machine must be reset by cycling the toggle switch from ICE to OFF to ICE.

INDICATOR LIGHT

Before 48 hours have elapsed:

After a Standby Mode has been initiated the HES1 light will flash anytime the toggle switch is placed in the OFF position.

After 48 hours have elapsed:

The SafeGuard will be automatically erased from memory and the HES1 light will not flash.

No Ice Production SafeGuard Checklist

Possible Problem List	Corrective Action List
Ice machine evaporator has mineral buildup	Clean the ice machine
Damper door removed or incorrectly installed	Refer to component identification for correct placement
The ice damper is binding	Adjust hall effect sensor housing screws in/out, check ice chute placement and hose clamp
Disconnected or defective damper door sensor	Refer to component identification and verify sensor at damper door is attached
Ice frozen to auger/evaporator	Allow evaporator to thaw 1 hour, then retry.
Low voltage	Voltage must be within $\pm 10\%$ of nameplate voltage.
Gear motor doesn't run, compressor will not run, compressor runs without producing ice	Check for power to remote condensing unit, if applicable contact a qualified service company

THIS PAGE INTENTIONALLY LEFT BLANK

THIS PAGE INTENTIONALLY LEFT BLANK

EC DECLARATION OF CONFORMITY

We hereby declare that our products, ice machines and Multiplex refrigeration equipment comply with all the essential requirements of the listed EC - directives.

Manufacturer:

Manitowoc Ice, Inc.
2110 S. 26th Street, P.O. Box 1720
Manitowoc, Wisconsin 54221-1720 USA

European Distributor:

Representative of Manitowoc Ice, Inc.:

Engineering Manager, (Printed name)

Representative of European Distributor:

Signature

Model and Serial No.

Applied EC Directives:

Applied Standards:

EN60335-1 Safety of household and similar electrical appliances
EN60335-2-24 Particular requirements refrigerators, food freezers and ice makers

EN55014 Electrical Motor Operated Appliances (Emissions)
EN55014 Electro Magnetic Compatibility (Immunity)
EN1819 -1 to -4 Refrigeration Plants

Low Voltage 73/23/EEC
EMC 89/336/EEC
Pressure Equipment 97/23/EC



8201043
08/25/03



© 2007 Manitowoc

Continuing product improvements
may necessitate change of
specifications without notice.

Part Number 000001196 11/11



Manitowoc Foodservice Group
2110 South 26th Street, P.O. Box 1720
Manitowoc, WI 54221-1720, USA
Ph: 920-682-0161 Fax: 920-683-7589
Visit us online at: www.manitowocfsg.com