

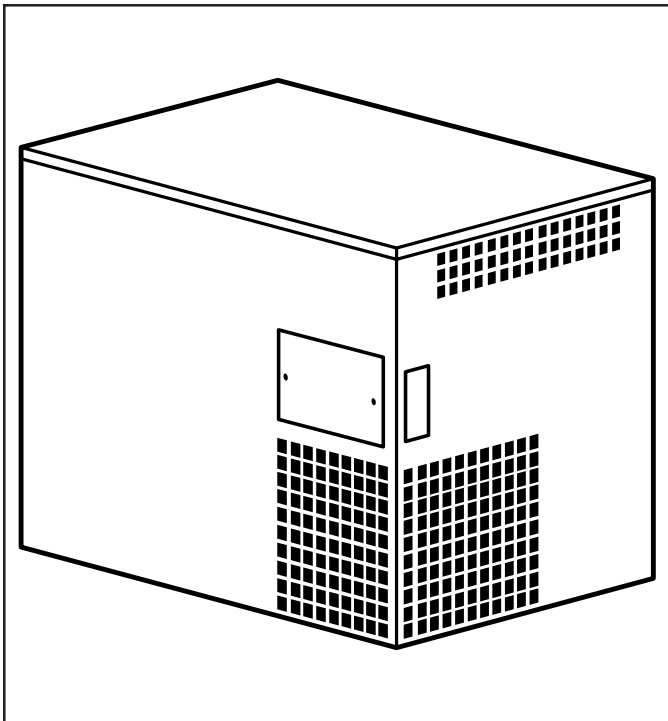

# POST MIX SODA REFRIGERATION UNITS

Models 2803/11/38/44

## INSTALLATION GUIDE



ISO 9001:2000  
Quality System Certified

### **Multiplex**

645 Park East Blvd, Suite 5 • New Albany, IN 47150  
Tel: 844.724.2273, 800.367.4233 • Fax: 812.246.7020  
[www.multiplexbeverage.com](http://www.multiplexbeverage.com)

In accordance with our policy of continuous product development and improvement, this information is subject to change at any time without notice.

# FOREWORD

---

**Multiplex Beverage developed this manual as a reference guide for the owner/operator, service agent, and installer of this equipment. Please read this manual before installation or operation of the machine. A qualified service technician should perform installation and start-up of this equipment, consult the *Troubleshooting Guide* within this manual for service assistance.**

If you cannot correct the service problem, call your Multiplex Service Agent or Distributor. Always have your model and serial number available when you call.

Your Service Agent \_\_\_\_\_

Service Agent Telephone Number \_\_\_\_\_

Your Local Multiplex Distributor \_\_\_\_\_

Distributor Telephone Number \_\_\_\_\_

Model Number \_\_\_\_\_

Serial Number \_\_\_\_\_

Installation Date \_\_\_\_\_

## UNPACKING AND INSPECTION

---

Note: The unit was thoroughly inspected before leaving the factory. Any damage or irregularities should be noted at the time of delivery.

## WARRANTY INFORMATION

---

Consult your local Multiplex Distributor for terms and conditions of your warranty. Your warranty specifically excludes all beverage valve brixing, general adjustments, cleaning, accessories and related servicing.

Your warranty card must be returned to Multiplex Beverage to activate the warranty on this equipment. If a warranty card is not returned, the warranty period can begin when the equipment leaves the Multiplex factory.

No equipment may be returned to Multiplex Beverage without a written Return Materials Authorization (RMA). Equipment returned without an RMA will be refused at Multiplex's dock and returned to the sender at the sender's expense.

Please contact your local Multiplex distributor for return procedures.

# TABLE OF CONTENTS

---

<b>FOREWORD</b> .....	<b>2</b>
<b>UNPACKING AND INSPECTION</b> .....	<b>2</b>
<b>WARRANTY INFORMATION</b> .....	<b>2</b>
<b>SAFETY</b> .....	<b>4</b>
<b>IMPORTANT SAFETY INSTRUCTIONS</b> .....	<b>4</b>
<b>CARBON DIOXIDE WARNING</b> .....	<b>4</b>
<b>QUALIFIED SERVICE PERSONNEL</b> .....	<b>4</b>
<b>SHIPPING, STORAGE, AND RELOCATION</b> .....	<b>4</b>
<b>ADDITIONAL WARNINGS</b> .....	<b>4</b>
<b>GROUNDING INSTRUCTIONS</b> .....	<b>5</b>
<b>DOS AND DON'TS</b> .....	<b>6</b>
<b>INSTALLATION</b> .....	<b>7</b>
<b>ATTENTION: MARINE INSTALLATIONS</b> .....	<b>7</b>
<b>OUTDOOR APPLICATIONS</b> .....	<b>7</b>
<b>PLUMBING SPECIFICATIONS</b> .....	<b>7</b>
<b>LOCATION REQUIREMENTS</b> .....	<b>7</b>
<b>REQUIREMENTS FOR POST MIX REFRIGERATION UNITS</b> .....	<b>7</b>
<b>INTRODUCTION</b> .....	<b>7</b>
<b>PREPARATION</b> .....	<b>7</b>
<b>INSTALLATION OF THE REFRIGERATION UNIT</b> .....	<b>8</b>
<b>POSITIONING THE REFRIGERATION UNIT</b> .....	<b>8</b>
<b>PLUMBING REQUIREMENTS</b> .....	<b>8</b>
<b>ELECTRICAL PROVISIONS</b> .....	<b>9</b>
<b>CONNECTING TOWERS AND CONDUIT</b> .....	<b>9</b>
<b>INSULATING CONNECTIONS</b> .....	<b>9</b>
<b>SEALING INSTRUCTIONS</b> .....	<b>9</b>
<b>CONNECTING SUPPLY LINES</b> .....	<b>10</b>
<b>PROCEED WITH THE FOLLOWING TESTS</b> .....	<b>11</b>
<b>TESTING THE CARBONATED WATER CIRCUITRY</b> .....	<b>12</b>
<b>SANITIZING PRIOR TO STARTUP</b> .....	<b>12</b>
<b>REMOTE CONDENSER REQUIREMENTS</b> .....	<b>12</b>
<b>CONNECTING THE PRE-CHARGED REFRIGERATION LINES</b> .....	<b>14</b>
<b>HOW TO SHORTEN THE LINE SET</b> .....	<b>14</b>
<b>HOW TO RE-CHARGE THE LINE SETS</b> .....	<b>14</b>
<b>AEROQUIP CONNECTION</b> .....	<b>16</b>
<b>OPERATION</b> .....	<b>16</b>
<b>PLACING EQUIPMENT IN OPERATION</b> .....	<b>16</b>
<b>ELECTRICAL SPECIFICATIONS</b> .....	<b>16</b>
<b>SERIAL PLATE LOCATION</b> .....	<b>17</b>
<b>USER MAINTENANCE</b> .....	<b>18</b>
<b>SANITIZING SYRUP CIRCUITS AND TESTING SYRUP CIRCUITRY</b> .....	<b>18</b>
<b>50M 50HZ MODELS</b> .....	<b>19</b>
<b>50M 60HZ MODELS</b> .....	<b>20</b>
<b>INDEX</b> .....	<b>23</b>

# SAFETY

## IMPORTANT SAFETY INSTRUCTIONS

Carefully read all safety messages in this manual. Learn how to operate this unit properly. Do not allow anyone to operate the unit without proper training and keep it in proper working condition. Unauthorized modifications to the this unit may impair function and/or safety and affect the life of the unit.

### CARBON DIOXIDE WARNING



**DANGER:** Carbon Dioxide (CO<sub>2</sub>) displaces oxygen. Exposure to a high concentration of CO<sub>2</sub> gas causes tremors, which are followed rapidly by loss of consciousness and suffocation. If a CO<sub>2</sub> gas leak is suspected, particularly in a small area, immediately ventilate the area before repairing the leak. CO<sub>2</sub> lines and pumps should not be installed in an enclosed space. An enclosed space can be a cooler or small room or closet. This may include convenience stores with glass door self serve coolers. If you suspect CO<sub>2</sub> may build up in an area, venting of the B-I-B pumps and / or CO<sub>2</sub> monitors should be utilized.

### QUALIFIED SERVICE PERSONNEL



**WARNING:** Only trained and certified electrical and plumbing technicians should service this unit. All wiring and plumbing must conform to national and local codes.

### SHIPPING, STORAGE, AND RELOCATION



**CAUTION:** Before shipping, storing, or relocating this unit, syrup systems must be sanitized. After sanitizing, all liquids (sanitizing solution and water) must be purged from the unit. A freezing environment causes residual sanitizing solution or water remaining inside the unit to freeze, resulting in damage to internal components.

### ADDITIONAL WARNINGS

 <b>WARNING</b>
Flush sanitizing solution from syrup system Residual sanitizing solution left in system could create a health hazard

	<b>WARNING</b> When using cleaning fluids or chemicals, rubber gloves and eye protection should be worn
--	--

	<b>WARNING</b> UNPLUG UNIT BEFORE SERVICING OR CLEANING ELECTRIC SHOCK HAZARD
---	---

Installation and start-up of this equipment should be done by a qualified service technician. Operation, maintenance, and cleaning information in this manual are provided for the user/operator of the equipment. **Save these instructions.**

# SAFETY

## GROUNDING INSTRUCTIONS



**WARNING:** Risk of electrical shock. Connect to a properly grounded outlet only.

This appliance must be grounded. In the event of malfunction or breakdown, grounding provides a path of least resistance for electric current to reduce the risk of electric shock. This appliance is equipped with a cord having an equipment-grounding conductor and a grounding plug. The plug must be plugged into an appropriate outlet that is properly installed and grounded in accordance with all local codes and ordinances.

**DANGER** – Improper connection of the equipment-grounding conductor can result in a risk of electric shock. The conductor with insulation having an outer surface that is green with or without yellow stripes is the equipment grounding conductor. If repair or replacement of the cord or plug is necessary, do not connect the equipment-grounding conductor to a live terminal. Check with a qualified electrician or serviceman if the grounding instructions are not completely understood, or if in doubt as to whether the appliance is properly grounded. Do not modify the plug provided with the appliance – if it will not fit the outlet, have a proper outlet installed by a qualified electrician.

**WARNING** – When using electric appliances, basic precautions should always be followed, including the following:

- a) Read all the instructions before using the appliance.
- b) To reduce the risk of injury, close supervision is necessary when an appliance is used near children.
- c) Do not contact moving parts.
- d) Only use attachments recommended or sold by the manufacturer.
- e) Do not use outdoors.
- f) For a cord-connected appliance, the following shall be included:
  - Do not unplug by pulling on cord. To unplug, grasp the plug, not the cord.
  - Unplug from outlet when not in use and before servicing or cleaning.
  - Do not operate any appliance with a damaged cord or plug, or after the appliance malfunctions or is dropped or damaged in any manner. Return appliance to the nearest authorized service facility for examination, repair, or electrical or mechanical adjustment.
- g) For a permanently connected appliance – Turn the power switch to the off position when the appliance is not in use and before servicing or cleaning.
- h) For an appliance with a replaceable lamp – always unplug before replacing the lamp. Replace the bulb with the same type.
- i) For a grounded appliance – Connect to a properly grounded outlet only. See Grounding Instructions.

**SAVE THESE INSTRUCTIONS**

# SAFETY

---

## DOS AND DON'TS

**Caution:** To Avoid Serious Injury

Important: Read the following warnings before beginning an installation. Failure to do so may result in possible death or serious injury.

**DO** Adhere to all National and Local Plumbing and Electrical Safety Codes.

**DO** Turn “off” incoming electrical service switches when servicing, installing, or repairing equipment.

**DO** Check that all flare fittings are tight. This check should be performed with a wrench to ensure a quality seal.

**DO** Inspect pressure on Regulators before starting up equipment.

**DO** Protect eyes when working around refrigerants.

**DO** Use caution when handling metal surface edges of all equipment.

**DO** Handle CO<sub>2</sub> cylinders and gauges with care. Secure cylinders properly against abrasion.

**DO** Store CO<sub>2</sub> cylinder(s) in well ventilated areas.

**DO NOT** Exhaust CO<sub>2</sub> gas (example: syrup pump) into an enclosed area, including all types of walk in coolers, cellars, and closets.

**DO NOT** Throw or drop a CO<sub>2</sub> cylinder. Secure the cylinder(s) in an upright position with a chain.

**DO NOT** Connect the CO<sub>2</sub> cylinder(s) directly to the product container. Doing so will result in an explosion causing possible death or injury. It is best to connect the CO<sub>2</sub> cylinder(s) to a regulator(s).

**DO NOT** Store CO<sub>2</sub> cylinders in temperature above 125°F (51.7°C) near furnaces, radiator or sources of heat.

**DO NOT** Release CO<sub>2</sub> gas from old cylinder.

**DO NOT** Touch Refrigeration lines inside units; some may exceed temperatures of 200°F (93.3°C).

**NOTICE:** All utility connections and fixtures shall be sized, installed, and maintained in accordance with Federal, State, and Local codes.

# INSTALLATION

## ATTENTION: MARINE INSTALLATIONS



**WARNING!** This unit is for use on vessels over 66 ft (20 m) in length. This unit should not be installed in the engine space of a gasoline-powered ship.

**NOTE:** This unit must be secured to the vessel during installation, TS models are **NOT** marine listed.

## OUTDOOR APPLICATIONS

TS Multiplex Beverage Recirculating units are approved and listed by Underwriters Laboratories (UL). However they are not UL approved for weather exposure applications. These units must be installed in areas where adequate protection from the elements is provided, all other models are ETL listed.

## PLUMBING SPECIFICATIONS

A 1" (2.54 cm) ID copper inlet water line equipped with a 3/4" (1.905 cm) FPT sweat adapter with shut-off must be supplied by plumber at rear of equipment. Appropriate floor drains should be provided within 6 ft (183 cm) of each unit installed. Note: The carbonator in this unit is provided with a dual check valve type back-flow preventer, which conforms to ASSE 1032. Potable water connections to the equipment must comply with the basic plumbing code of the Building Officials and Code Administrators International, Inc. (BOCA) and the Food Service Sanitation Manual of the Food and Drug Administration. Verify local plumbing code requirements.

## LOCATION REQUIREMENTS

Select a location for the refrigeration unit that meets the requirements of the building plans, local codes, and personnel. The unit must be positioned for free airflow as well as for future service. The following requirements must be met:

- 100 GPH (379 LTR/hr) potable water supply  
Models 2803/11/38
- Beverage quality CO<sub>2</sub> gas (bulk or bottled supply)  
with a minimum 3/8" (0.96 cm) line
- 200 GPH (757 LTR/hr) potable water supply  
Models 44/50
- One (1) Bag-In-Box (BIB) container of each post-mix syrup flavor.

**NOTE:** Refer to nameplate on side of refrigeration unit for voltage and amperage specifications. Make all electrical connections at the junction box located at the top rear of unit. Optional equipment may require additional power supplies.

**NOTE:** Potable water connections to the equipment must comply with local plumbing code requirements, particularly the back-flow prevention requirements.

## REQUIREMENTS FOR POST MIX REFRIGERATION UNITS

- Conduit can be run through floor or ceiling chase.
- Syrup supply can be located on stand or adjacent to refrigeration unit.



**IMPORTANT:** The remainder of these instructions is to be completed by an authorized Multiplex Installer.

## INTRODUCTION

These equipment instructions are intended to assist qualified personnel in the unpacking, locating and the initial operation of the Multiplex Beverage Equipment Post Mix Refrigeration Unit.



**IMPORTANT:** This publication should be saved for future reference. Read instructions before attempting installation.

## PREPARATION

The Multiplex Beverage Equipment Post Mix Refrigeration Unit is pre-assembled in the factory and requires minimum installation.

For future reference or to be used when ordering parts, [record the Model Number, Serial Number, Part Numbers of Unit, Condenser \(if remote\), Towers, etc., and Date of Installation on the inside of this Manual](#). Leave manual on site in a safe place. Do not discard manual.

# INSTALLATION

## INSTALLATION OF THE REFRIGERATION UNIT

Before proceeding with installation, verify that all requirements for roof mounted remote condenser units (if applicable) have been satisfied. If unit has a remote condenser, refer to the [instructions on installing the remote condenser](#) supplied with the Condensing unit and refer to section on [installation of remote refrigeration line sets](#).

### POSITIONING THE REFRIGERATION UNIT

Identify the appropriate location where the refrigeration unit and any optional equipment will be placed. Locate and assemble all optional equipment that is to be installed on the refrigeration unit. Inspect for shortages and complete kit assemblies.

1. Install all brackets and support legs (if not using optional stand) before placing equipment in the proper location.
2. Select a location for the unit that meets the requirements of the building plans, local codes, and personnel. The unit should be placed in a location that will allow ease of maintenance and no obstruction of airflow.
3. A floor drain must be available within six (6) feet (183 cm) of the unit and access to incoming water supply and electrical outlets is a pre-installation requirement.
4. The backside of the unit should be at least six (6) inches (15.2 cm) away from the wall (refer to figure 1).
5. Remove the top cover of the unit and expose the water bath and conduit connections.

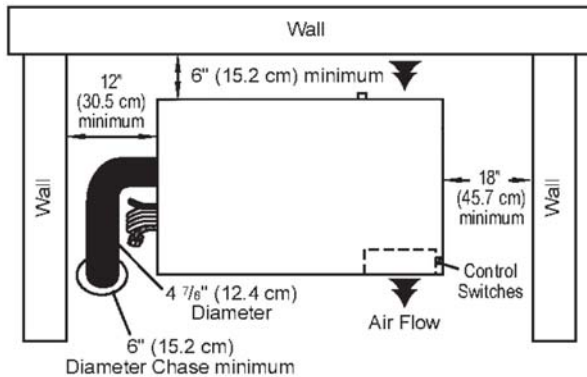

TOP VIEW

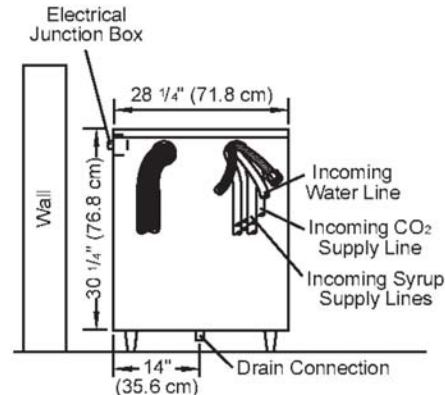

SIDE VIEW

### PLUMBING REQUIREMENTS

Incoming water supply should be provided before installation of the refrigeration unit and should comply with local plumbing requirements.

1. A minimum 1" (2.54 cm) water supply line with a manual shut-off valve must be plumbed at least 6ft (183 cm) from the unit. The incoming water supply pressure must not exceed 70 PSI static (4.8 bar) and be no less than 40 PSI (2.8 bar) dynamic.
2. Locate the drain hose, bracket, and two (2) screws provided in the Installation Kit. Attach the drain hose to the water bath overflow tube located on the bottom of the Refrigeration Unit.
3. Connect the Water Manifold Supply Line, located on the bulkhead panel in the motor compartment to the main water supply. The Main Water Supply Shut-off Valve must remain in the "OFF" position. If a water filter is to be installed, connect the line to the outlet fitting of the filter. Plumb according to applicable plumbing codes.
4. When a Water Cooled Condenser is installed, a copper supply line (not supplied with unit) must be plumbed to the 3/8" (.965 cm) Male Flare fitting installed in the Water Shut-off Assembly. The Shut-off must be placed in the "OFF" position. A copper drain line (not supplied) is to be connected to the outlet fitting of the Water Cooled Condenser and routed to the floor drain.

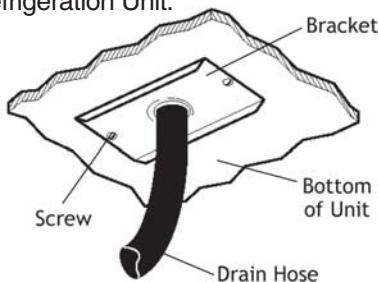

DRAIN HOSE CONNECTION

# INSTALLATION

## ELECTRICAL PROVISIONS

Electrical service must agree with the requirements noted on the unit serial number plate. An opening is provided in the side of the unit to route service to the field-wiring box. Wiring must conform to applicable codes.

1. For domestic units, one or more 15 Amp, 120 Volt wall receptacle will be required if accessories such as a CO<sub>2</sub> Control Assembly, Air Pump, or Water Booster Pump are installed with the unit.
2. For international versions, refer to codes directly on the optional equipment installed and to the wiring diagram.

## CONNECTING TOWERS AND CONDUIT

Refer to the installation instructions packaged with the towers or other dispensing equipment and with the conduit used.

## INSULATING CONNECTIONS

1. Make sure all exposed carbonated water and syrup lines are well insulated on towers to conduit, conduit junctions, refrigeration unit to conduits, and Drive-Thru junction.
2. To insulate the above use the leftover conduit sections and tape.
3. Cut the conduit sections to fit like a glove over the exposed lines and fittings. A little extra time spent doing a professional job initially will eliminate a call back in several days to make corrections.

## SEALING INSTRUCTIONS

Refer to the installation instructions packaged with the conduit used. (Aerosol foam not supplied with unit or conduit)

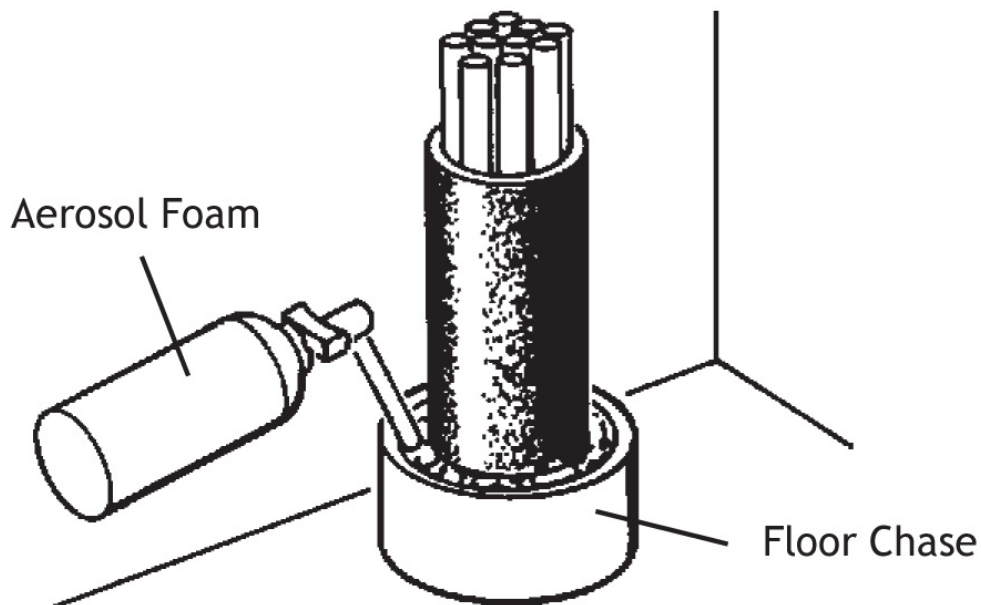

SEALING THE FLOOR CHASE

# INSTALLATION

## CONNECTING SUPPLY LINES

Pre-installation of towers is required and the appropriate syrup supply must be connected to the corresponding tower. The valves are numbered 1-6, 1-8, or 1-10 from left to right viewing from the front of the tower.

1. For a two (2) tower installation, refer to the Syrup Supply Line Diagram below. The syrup product supply boxes can be positioned on a BIB rack in a convenient location near the soda system.

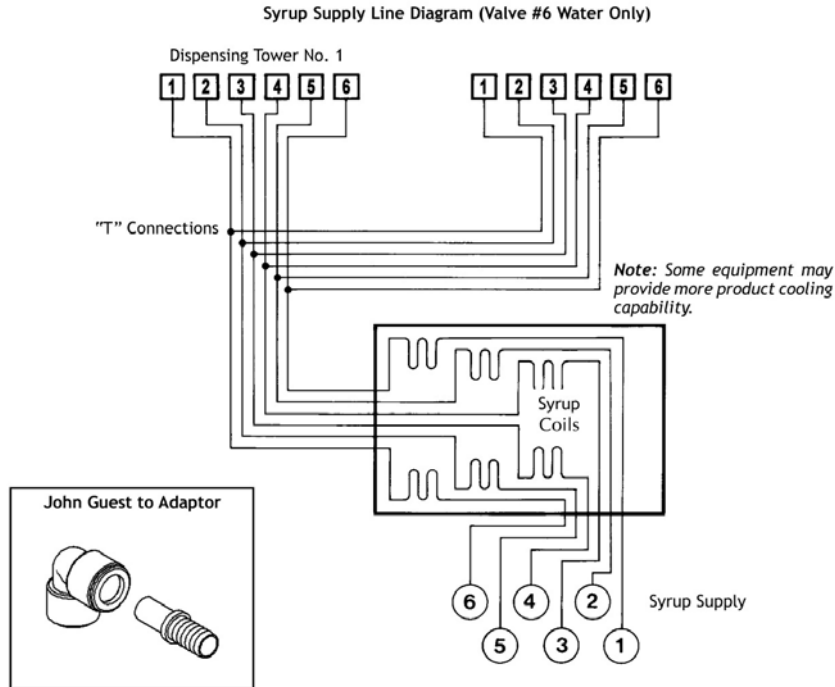

**Note:** Refer to the optional equipment component installation instructions for completion (if applicable) of the beverage system. Do not connect the syrup supply at this time.

2. Locate the conduit supply lines for the refrigeration unit. There are four (4) ½" (1.27 cm) carbonated water lines marked in sets for the system. Connect the yellow carbonated water supply line (7) to the yellow carbonated water return line (A). Connect the blue carbonated water supply line (8) to the blue carbonated water return line (B). Refer to the Carbonated Water Supply Line Diagram below.

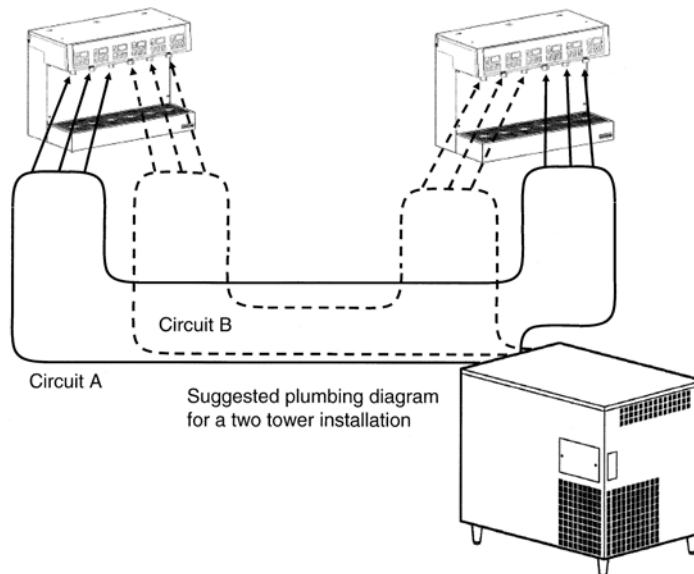

# INSTALLATION

## CONNECTING SUPPLY LINES

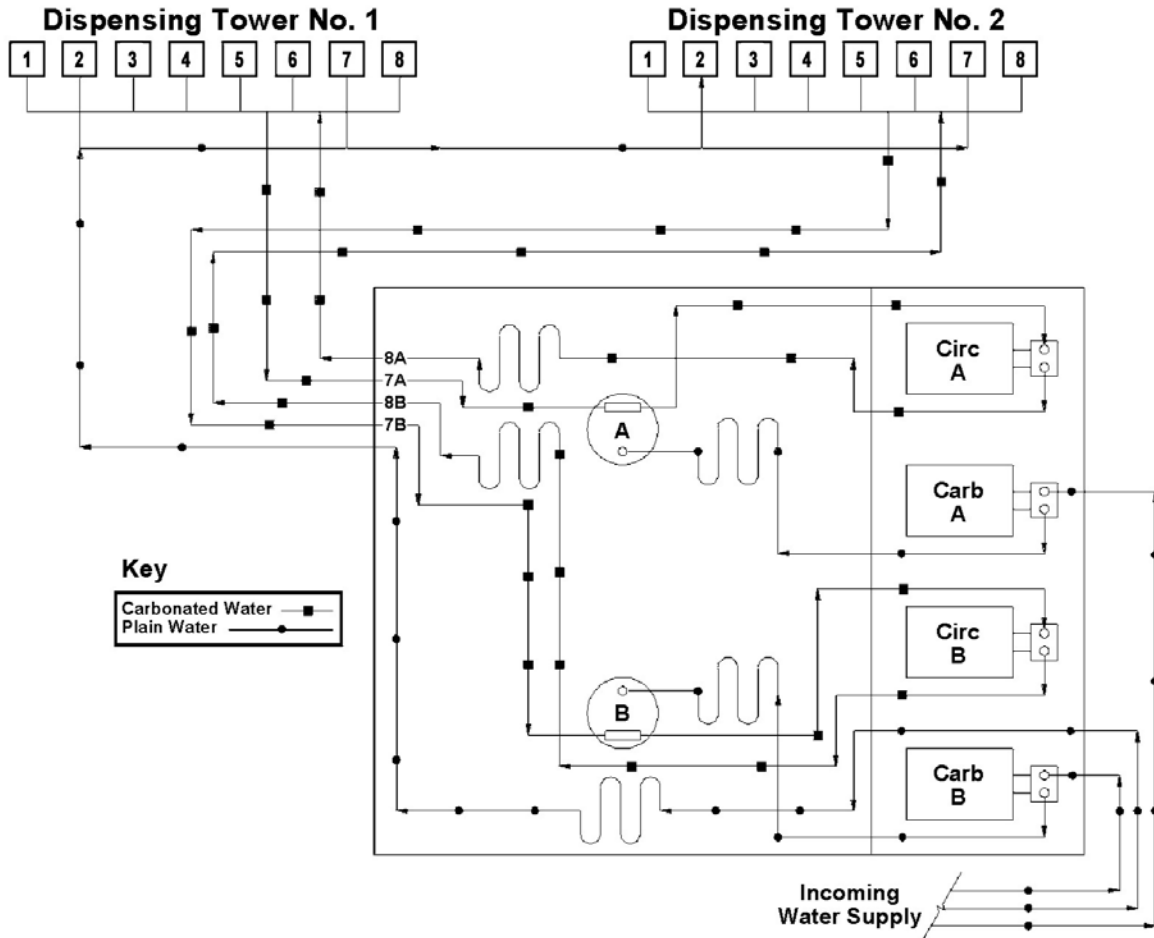

- Locate the one (1) and the (8) 3/8" (.965 cm) syrup lines. Note: Braided syrup lines located inside the conduit bundle are used to prevent flavor transfer. Braided syrup lines located outside the conduit bundle are used for unsweetened tea or syrup that are like to precipitate (if applicable).
- Insert the eight (8) John Guest adaptors into the elbows on the syrup coils. Note: The 3/8" (.965 cm) and 1/2" (1.27 cm) adaptors are supplied for either size conduit.
- Locate the plain water line(s) in the conduit. Determine the size, either 3/8" (.965 cm) or 1/2" (1.27 cm) and the number (one [1] or two [2]). Jumper the line labeled "W". Either connect two (2) splicers for two (2) water lines or use one of the tees supplied to connect the two (2) lines together.
- Insert the conduit supply lines into the left hand opening of the refrigeration unit. Connect the John Guest fittings requiring the longest tube from the end of the insulation first. Use two (2) tab clamps each per connection. It may be necessary to moisten the lines and fittings before inserting the tubing over the barbed fitting. Alter the remaining lines to make the routing neat and secure.
- Connect the CO<sub>2</sub> supply line from the CO<sub>2</sub> tank regulator to the line marked CO<sub>2</sub> in the unit using a 3/8" (.965 cm) by 3/8" (.965 cm) splicer and secure with Oetiker clamps.

## PROCEED WITH THE FOLLOWING TESTS

- Assure that overflow tube is firmly seated, not leaking.
- Check Conduit for proper support and insulation.
- Cycle Carbonator "A" momentarily.
- Cycle Carbonator "B" momentarily (if applicable).
- Cycle Circulating Motor "A" momentarily.
- Cycle Circulating Motor "B" momentarily (if applicable).
- Cycle Compressor momentarily.
- Assure that Agitator Motor is running.
- Assure that Ice Bank Control Probe is securely attached to evaporator coil.

# INSTALLATION

## TESTING THE CARBONATED WATER CIRCUITRY

1. Turn "ON" the CO<sub>2</sub> Tank Regulator corresponding to circuit "A". Adjust the setting to 90 PSI (6.2 bar).
2. Open the pressure relief on the top of the carbonator tank for circuit "A". Make sure the other valve is closed.
3. Allow the CO<sub>2</sub> gas to enter the system.
4. Wait for 2 or 3 minutes before turning "OFF" the CO<sub>2</sub> Tank Valve. This will allow the lines to expand under pressure.
5. Turn "OFF" CO<sub>2</sub> Vessel Regulator Valve. Observe pressure on the high pressure gauge. The needle dropping will indicate a loss in pressure. If the needle continues to fall, a leak in the system must be corrected. Observe the pressure for several minutes.
6. The greater the leak, the faster the needle will drop. The smaller the leak, the slower the needle will drop.
7. Repeat procedure for circuit "B" if applicable.
8. Turn "ON" the water supply. Turn "ON" the water supply to both carbonators. Turn "ON" the rocker switches marked carbonator "A" (and "B" if applicable). Note: Carbonator motors should run approximately 2 minutes before shutting "OFF" on initial start-up.
9. After carbonators "A" (and "B" if applicable) cycle OFF", turn "ON" the rocker switches marked circulator "A" (and "B" if applicable).

**NOTE: It may be necessary to use soap solution at all connections to locate a very small leak.**

## SANITIZING PRIOR TO STARTUP

Prior to putting system into service, clean and sanitize the system. During this process, check all syrup circuit connections from the BIB connector through the water bath area to the inlet fitting and stainless steel tubing of the tower. Check syrup circuitry on all towers by activating the valve of the circuit being tested. Repair any leaks prior to hooking up syrup. See **SANITIZING SYRUP CIRCUITS AND TESTING SYRUP CIRCUITRY** in the User Maintenance section.

## PRE-INSTALLATION REQUIREMENTS

### Multiplex Remote Condenser Requirements

1. Installation and maintenance are to be performed only by qualified refrigeration personnel. These technicians must have EPA certification (USA), are familiar with local codes and regulations, and are experienced with this type of remote refrigeration equipment.
2. As a condition of the warranty, the check, test and start-up procedure must be performed by qualified personnel. Because of possible shipping damage, check both the condensing unit and refrigeration unit(s) for refrigerant leaks.
3. If the refrigeration unit is located on a roll out platform, you must coil up to one round between the back of the stand and the wall. This allows pull out of the refrigeration unit for servicing.
4. If the refrigeration unit is located in a stationary location, you must remove excess refrigeration tubing as described below.

this trap allows oil to reach the condenser and return to the compressor.

3. The easiest method to create a trap is to bend the tubing (smoothly, no kinks) into the trap form (refer to figure 3).
4. The trap(s) should be of minimum height of 3" (7.6 cm) and a width of 6" (15.2 cm) to minimize oil accumulation. The traps can also be bent out of the refrigeration tubing. Carefully bend the tubing down 12" and sweeping the tubing back up.
5. It is critical that the Multiplex remote condensing line size specifications for the specific model be maintained. The specifications are 1/2" discharge and 3/8" liquid lines.

### Multiplex Pre-charged Refrigeration Lines Requirements

1. Both the discharge and liquid remote condensing lines should be kept to a minimum distance for maximum performance. All Multiplex systems are capacity rated to 100 ft (30.5 m) tubing distance between the compressor and condenser.
2. Any vertical rise 25 ft (7.62 m) or greater must have a manufactured or installed trap (bend), in the discharge refrigeration line from the compressor to the remote condenser. A trap is necessary for every additional 25 ft (7.62 m) vertical rise. When excessive vertical rise exists,

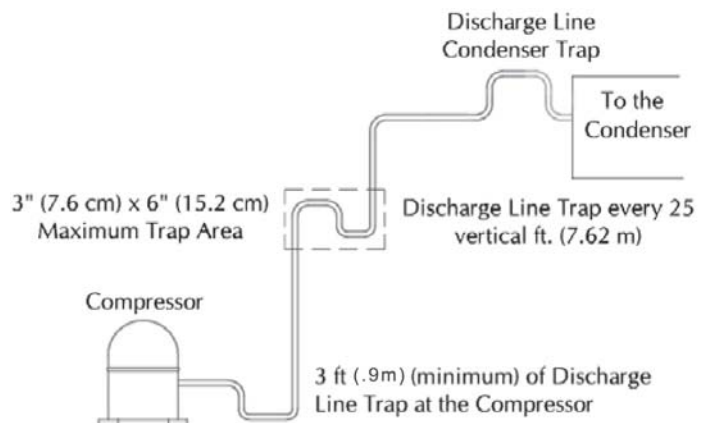

# INSTALLATION

## INSTALLING THE MULTIPLEX REMOTE CONDENSER

The Multiplex remote condensing units have a 208-230 Volt, 50/60 HZ, 1 PH fan motor that includes a permanent split capacitor and internal overload protection. The electrical wires from the refrigeration unit wire to the condenser. The electrical installation should be in accordance with local codes, national Electrical Code and regulations.

1. Determine a position for installation that will allow access for maintenance and is free from obstruction. Verify hot air discharge from other condensers do not interfere with the inlet of this condenser.
2. Install the four (4) legs to the sides of the condenser using the mounting bolts provided.
3. The General Contractor or Owner must secure two (2) treated lumber 4" x 4" x 36" (or longer). You may then mount the remote condenser to the treated lumber (refer to figure 1).
4. The General Contractor or Owner must install a 3" pitch pot in the roof (refer to figure 2). Then seal for weather protection.
5. Locate the pre-charged refrigeration lines shipped with the system. These lines should be a correct length for the building design. Avoiding any kinks, neatly route these lines from the remote condenser to the refrigeration unit. Excess refrigeration tubing must be handled in one of two ways. When coiling the excess tubing, make sure the inlet to the coil is at the top of the coil and the exit is the bottom of the coil. There can be no more than one turn to the coil. If you have more tubing, you must cut out the excess before connecting the ends. When cutting the tubing, you must first evacuate the refrigerant (line sets have a positive refrigerant holding charge of two to three ounces). After shortening and welding the tubing together again, you must vacuum the tubing to 250 microns. Then recharge the tubing with the appropriate refrigerant at 0.72 ounces per foot of new tubing length measured one way.

**Caution:** Excess refrigeration tubing must be properly cared for before being connected to either the remote condenser or refrigeration unit.

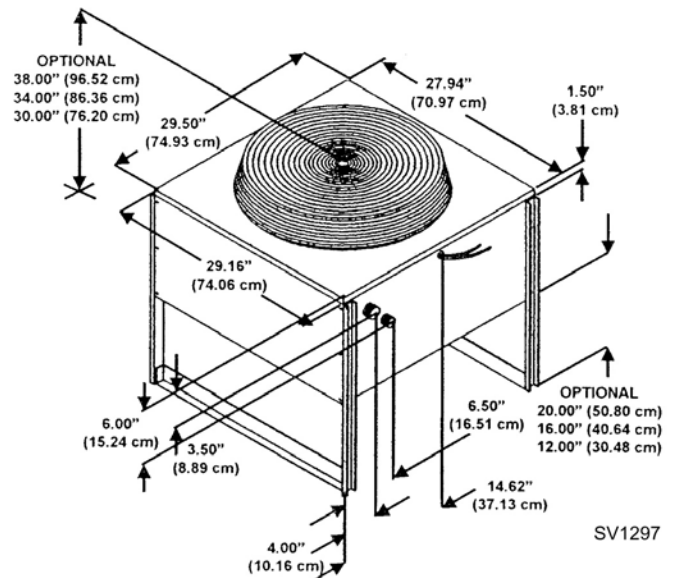

Figure 5

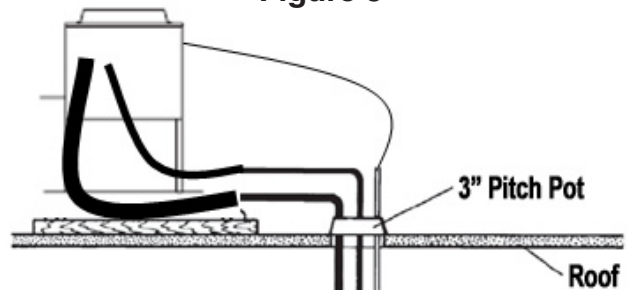

Figure 6



*Caution: Excess refrigeration tubing must be properly cared for before being connected to either the remote condenser or refrigeration unit.*

# INSTALLATION

## CONNECTING THE PRE-CHARGED REFRIGERATION LINES

Note: Before connecting the pre-charged refrigeration lines, the refrigeration unit must be properly located, leveled, and the water bath filled 1" (2.5 cm) below the installed drain pipe.

1. Attach low side gauge set to service port on each line set to verify positive pressure within the line set.
2. Always make the connections at the condenser first, using the end of the pre-charged lines with the valve ports.
3. Connect the condenser side with the quick connectors (discharge and liquid) up to condenser. Refer to the section titled "Aeroquip connection" in these instructions.
4. Connect the refrigeration unit side with the quick connects (discharge and liquid). Make sure to provide discharge trap at back of refrigeration unit, or bend discharge line down 12" and then up smoothly (no kinks) to provide a trap.
5. If a low refrigerant charge is detected, recover and recharge the system adding the unit name plate charge, condenser name plate charge, and the refrigerant line charge at 0.72 ounces per foot (0.067 kg/m), measured one way.

*Note: If for any reason the lines are damaged and / or leaking or the lines no longer charged, refer to "How To Re-charge the Line Sets". If the line set is too long for the application, refer to "How To Shorten the Line Sets".*

## HOW TO SHORTEN THE LINE SET

1. Do not connect either end of the tubing to the system before everything is set in place. Standard refrigeration practices must be followed regarding the tubing installation.
2. Excess refrigeration tubing must be handled in one of two ways. With a short amount of excess tubing (about 10 feet), you may coil that amount vertically between the condenser and refrigeration unit. When coiling the excess tubing, make sure the inlet to the coil is at the high side of the coil and the exit is the low side of the coil. There can be no more than one turn to the coil. The coil must continue in a downward spiral with no overlaps, similar to a cork screw. If you have more tubing, you must cut out the excess before
- connecting the ends. When cutting the tubing, you must first evacuate the refrigerant.
3. After shortening the tubing and welding together again, you must vacuum the tubing to 250 microns.
4. Recharge the tubing with the appropriate refrigerant at 0.72 ounces per foot (0.067 kg/m) of new tubing length, one way.

## HOW TO RE-CHARGE THE LINE SETS

Note: This procedure to be used only with damaged or evacuated line sets or with unknown refrigerant type.

1. Repair any damages to the line sets before proceeding.
2. With the remote condenser lines properly hooked and sealed to the condenser, evacuate to 250 microns for 1 hour, using both Schrader ports on the service line set.
3. For units with model numbers beginning with SSxxxxxx, charge the condenser and line set as described here. Add 0.72 oz/ft (0.067 kg/m) of remote line set (one way run distance) plus condenser name plate charge.
 

Example:  
 45 ft of line set  
 45 x 0.72 oz = 32.4 oz  
 32.4 oz + condenser charge = Total charge
4. Connect line sets to the proper discharge and liquid mating connectors on the refrigeration unit using quick connects. Refer to the section titled "Aeroquip Connection" in these instructions.

If the line set and the main refrigeration unit are connected, you must also add that refrigerant charge.

Recharging line sets and condensers connected to refrigeration model numbers TSxxxxxx. Charge according to the nameplate charge on the refrigeration unit. That is enough refrigerant for up to 100 feet of tubing plus the Multiplex condenser. If you have another brand condenser, please add additional charge for the condenser (example: up to three pounds for a MAC condenser).

# INSTALLATION

## HOW TO RE-CHARGE THE LINE SETS (CONTINUED)

5. Be sure to observe proper refrigeration techniques when running the line set.
  - a. The discharge line should loop down at the compressor end to trap liquid from returning to the compressor (refer to figure 3), unless you are coiling refrigeration tubing behind the unit.
  - b. The discharge line should loop above discharge connector at the condenser to resist liquid returning to the compressor. Any excess tubing should be removed from the line set before the line set is connected to any equipment.
  - c. The discharge line should have one P trap every 25 ft (7.6 m) of vertical rise to allow oil to stair-step up to the condenser and eventually return to the compressor.

*Note: When the connections are made, the seal in the couplings are broken and if removed for any reason, the refrigerant charge will be lost.*

*Caution: Relays and terminal block are energized from each remote unit. Turn "off" switches on each unit before opening quick disconnect switch on condensing unit. On the completion of the wiring of the remote condenser make sure the electrician placed the switch lever in the "on" position. This switch must be "on" before turning "on" the refrigeration toggle switch on the unit. Also, the water bath must be filled with water.*

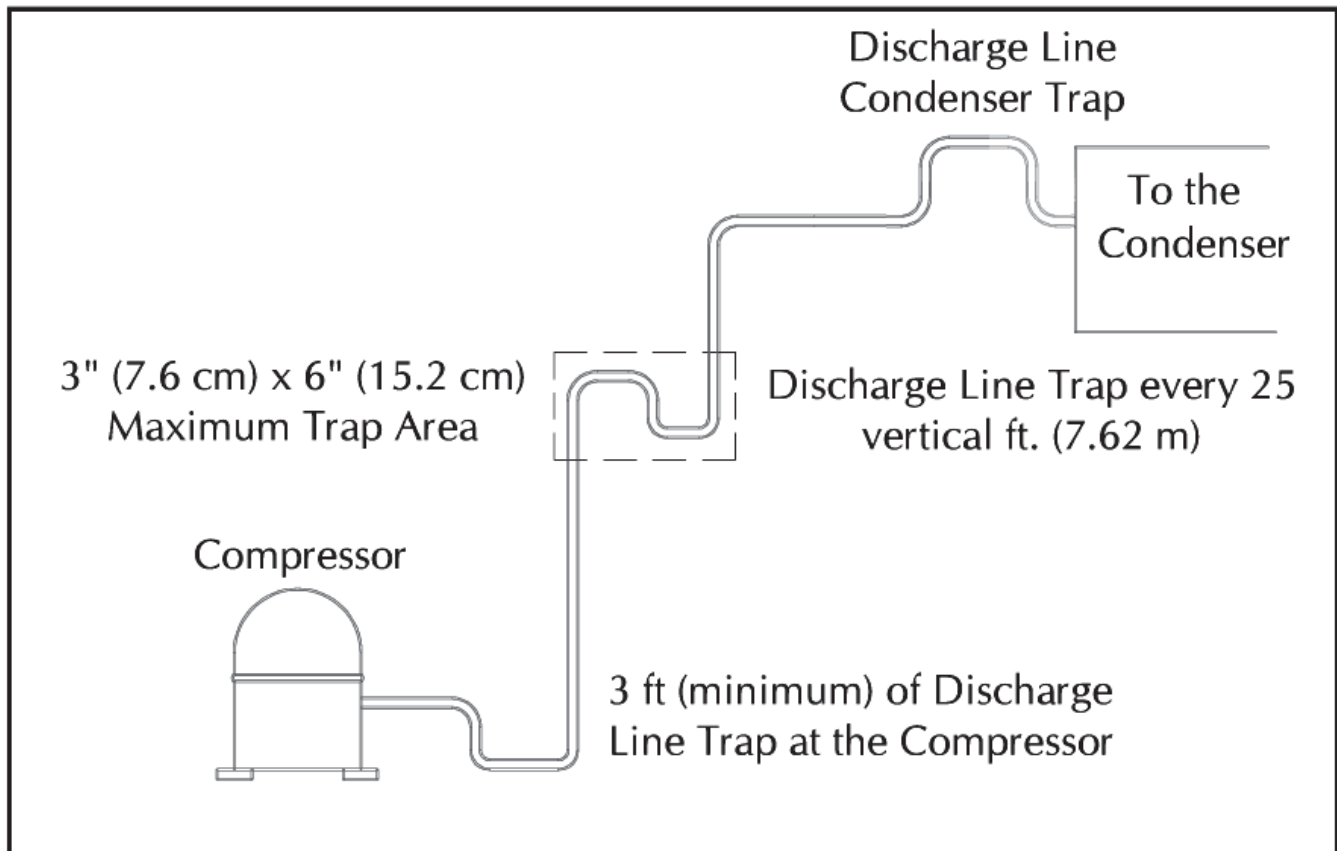

Figure 7



**CAUTION:** Relays and terminal block are energized from each remote unit. Turn "off" switches on each unit before opening quick disconnect switch on condensing unit. On the completion of the wiring of the remote condenser make sure the electrician placed the switch lever in the "on" position. This switch must be "on" before turning "on" the refrigeration toggle switch on the unit. Also, the water bath must be filled with water.

# INSTALLATION

## AEROQUIP CONNECTION

1. Lubricate male half diaphragm and synthetic rubber seal with refrigerant oil.
2. Thread male coupling to its proper female half by hand to insure proper mating of threads.
3. Use proper wrenches (on coupling body hex and its union nut) and tighten union nut until coupling bodies "bottom".  
*Note: You must use a wrench on the body to keep the body from turning while tightening the nut with the second wrench. If the body turns excessively, the piercing seal will be damaged.*
4. Use proper wrenches to tighten an additional ¼ turn (90°). This final ¼ turn is necessary to insure the formation of a leak proof joint. Alternately, use a torque wrench to tighten ½" coupling to 40 ft lbs and 3/8" fitting to 11 ft lbs.
5. Leak check all your connections. If you detect any leaks, repair and recheck.
1. Fill the refrigeration unit water bath tank with water to

## OPERATION

### PLACING EQUIPMENT IN OPERATION

Before placing equipment in operation, verify that all requirements for roof mounted Remote Condenser Units (if applicable) have been satisfied. Refer to the instructions on installing the Remote Condenser.

1. Fill the refrigeration unit water bath tank with water to within 1/2" (1.27 cm) of the top of the overflow tube.
2. Open the manual Water Shut-off Valve to the Water Cooled Condenser (if applicable).
3. Turn "ON" the rocker switch labeled "Refrigeration" to begin building an ice bank.
4. Turn "ON" the rocker switch labeled "Agitator".
5. Ice should begin to form on the evaporator coils in approximately 2 hours.
6. The refrigeration unit will build an ice bank in approximately 4 to 6 hours.
7. If optional CO<sub>2</sub>/Water Control Panel has been installed on the refrigeration unit, refer to the installation instructions for operation and testing the circuits for leaks.
8. The carbonation circuits "A" and "B," as well as the syrup circuits must be checked for leaks and possible cross circuits before turning "ON" the water supply to carbonator pumps.

## ELECTRICAL SPECIFICATIONS

POST-MIX SODA REFRIGERATION UNIT SPECIFICATIONS								
MODEL	PART NUMBER	VOLTAGE	HZ	PHASE	WIRES	BREAKER	CONDENSER	REMOTE
11MA04	SS901120	120VAC	60	1	3	30 AMP	Air Cooled	NA
11MAX04	SS901122	230 VAC	50	1	3	16 AMP	Air Cooled	NA
2803AX04	SS902832	230 VAC	50	1	3	16 AMP	Air Cooled	NA
2803A04	SS902850	120VAC	60	1	3	25 AMP	Air Cooled	NA
38MA04	SS903850	120VAC	60	1	3	30 AMP	Air Cooled	NA
38MWO4	SS903852	120VAC	60	1	3	30 AMP	Water Cooled	NA
44MA04	SS904480	208/230 VAC	60	1	3	30 AMP	Air Cooled	NA
44MR04	SS904481	208/230 VAC	60	1	3	30 AMP	Remote Air Cooled	00904814
44MW04	SS904482	208/230 VAC	60	1	3	30 AMP	Water Cooled	NA
44MAX04	SS904483	230 VAC	50	1	3	25 AMP	Air Cooled	NA
44MRX04	SS904484	230 VAC	50	1	3	25 AMP	Remote Air Cooled	00904814
50MA04	TS905050-263	120/208-230 VAC	60	3	4	30 AMP	Air Cooled	NA
50MR04	TS905051-263	120/208-230 VAC	60	3	4	30 AMP	Remote Air Cooled	00904814
50MW04	TS905052-263	120/208-230 VAC	60	3	4	30 AMP	Water Cooled	NA
50MR04 Q/T	TS905046-263	120/208-230 VAC	60	3	4	30 AMP	Remote Air Cooled	00904814
50MAX04	TS905053-353	230/400 VAC	50	3	5	16 AMP	Air Cooled	NA
50MRX04	TS905054-353	230/400 VAC	50	3	5	16 AMP	Remote Air Cooled	00904814
50MWX04	TS905055-353	230/400 VAC	50	3	5	16 AMP	Water Cooled	NA



**NOTICE:** See nameplate on refrigeration unit for electrical specifications. Make all electrical connections at the junction box located at the top of the rear wall of the refrigeration unit pump compartment in accordance with applicable electrical codes. Power disconnect must be installed within sight of unit.

# OPERATION

## SERIAL PLATE LOCATION



A **Manitowoc** Company

---

**Manitowoc Ice, Inc.**  
2110 S. 26th. St.  
P.O. Box 1720  
Manitowoc, WI 54221-1720

REMOTE BEVERAGE COOLER

---

**MODEL**  
44MA04

**PART NUMBER**  
SS904480

**SERIAL NUMBER**  
XXXXX4525



**ELECTRICAL RATING:** 230-208 VAC 1PH 60HZ 3 WIRE (2W+G) SYSTEM

COMPONENT	QTY	VOLTS	AMPERES	POWER
COMPRESSOR	01	230-208	9.8 RLA 51.0 LRA	1.00HP
FAN MOTOR	01	230-208	1.0	50W
CARBONATOR MOTOR	02	230	2.4	0.33HP
CIRCULATOR MOTOR	01	230	2.4	0.33HP
AGITATOR MOTOR	01	230	0.6	25W

---



**MAX. FUSE OR HACR TYPE CIRCUIT BREAKER:** 30A T/D **REFRIGERANT:** 404A

**MINIMUM BRANCH CIRCUIT AMPACITY:** 21.0 **UNIT CHARGE:** 57 OZ

**REFRIGERATION DESIGN PRESSURE:** HI-332 PSIG LO-174 PSIG

**IF A SUPPORT STAND IS USED, USE ONLY MULTIPLYPLEX MODEL:** 4450

**SYRUP LINE PRESSURE MUST NOT EXCEED 75 PSIG. CHECK INSTRUCTIONS FOR PROPER CO<sub>2</sub> PRESSURE SETTINGS.**

3024026  
C US

CONFORMS TO UL STD 471  
CERTIFIED TO CSA STD  
C22.2 NO 120

Made in USA

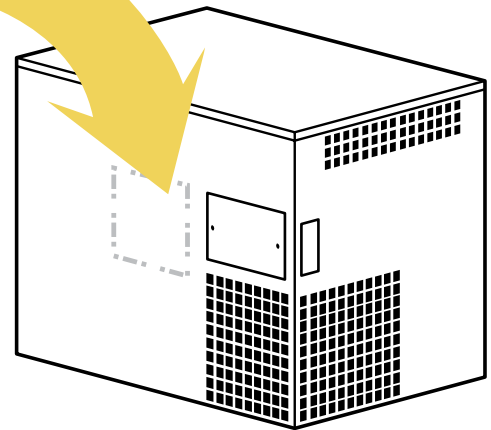

# USER MAINTENANCE

## SANITIZING SYRUP CIRCUITS AND TESTING SYRUP CIRCUITRY

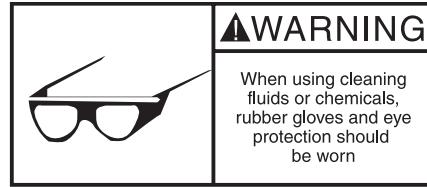
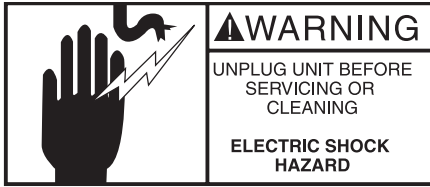

The following is needed to clean and sanitize the Bag-in-Box (BIB) beverage system:

- Three (3) clean buckets
  - Plastic brush or soft cloth
  - Mild detergent
  - Unscented bleach (5% NaClO) or commercial sanitizer
  - Bag-in-Box (BIB) connector
1. Prepare the following in buckets:
    - Bucket 1 – warm (100° F/38° C) tap water for rinsing
    - Bucket 2 - mild detergent and warm (100° F/38° C) water
    - Bucket 3 – mix a solution of unscented bleach (5% NaClO) or commercial sanitizer and warm 100° F/38° C) water. Mixture should supply 100 PPM available chlorine —1/4 oz. (30ml) bleach to 1 gallon (3.8 liters) water.
  2. Disconnect the “syrup-line side” of the BIB connector.
  3. Rinse connector in warm (100° F/38° C) water.
  4. Connect syrup connector to BIB connector and immerse both into Bucket 1. A “bag side” connector can be created by cutting the connector from an empty disposable syrup bag.
  5. Draw rinse water through system until clean water is dispensed. Most beverage valves allow the syrup side to be manually activated by depressing the syrup pallet.
  6. Connect Bucket 2 to system.
  7. Draw detergent solution by activating valves until solution is dispensed.
  8. Repeat steps 2-7 until all syrup circuits contain detergent solution.
  9. Allow detergent solution to remain in system for five (5) minutes.
  10. Connect Bucket 3 to system.
  11. Draw sanitizing solution through system by actuating valves until solution is dispensed
  12. Repeat step 11 until all syrup circuits contain sanitizer solution.
  13. Allow sanitizer to remain in system for fifteen (15) minutes.
  14. Remove nozzles and diffusers from beverage valves.
  15. Scrub nozzles, diffusers, and all removable valve parts (except electrical parts) with a plastic brush or a soft cloth and the detergent solution.
  16. Soak nozzles, diffusers, and removable valve parts (except electrical parts) in sanitizer for fifteen (15) minutes. NOTE: DO NOT soak nozzles, diffusers, or other valve parts overnight.
  17. Replace nozzles, diffusers, and valve parts.
  18. Connect Bucket 1 to system.
  19. Draw rinse water through system by activating valves until no presence of sanitizer is detected.
  20. Attach syrup connectors to BIB’s.
  21. Draw syrup through system by activating valves until only syrup is dispensed.
  22. Discard first two (2) drinks.

# EXPLODED VIEWS

**\*Drawing Details on next page**

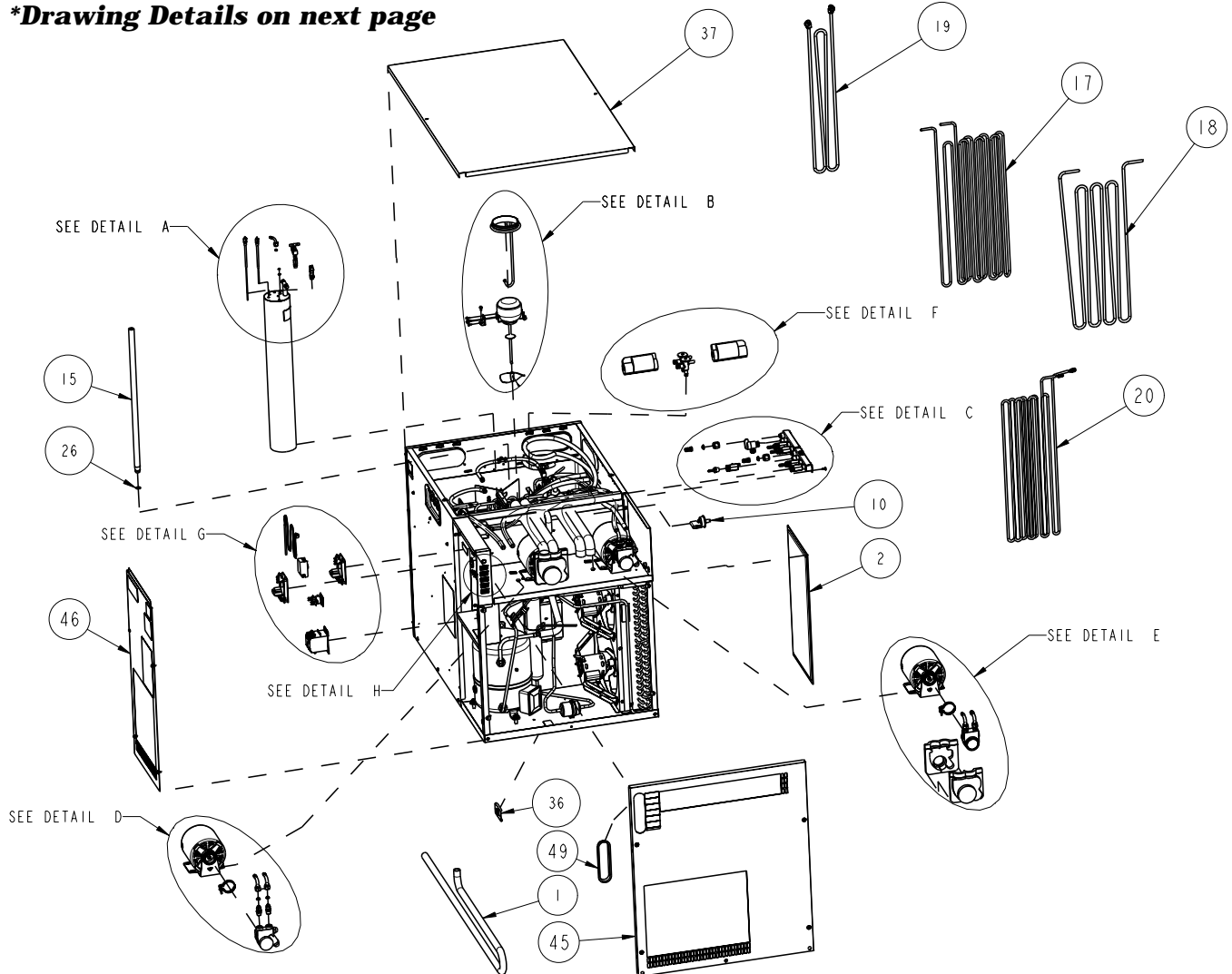

NO.	Part Number	Description
1	00000979	TUBE RUBBER .75IDX.125WX72
2	000001430	FILTER AIR
3	000001973	MANIFOLD WATER 3 OUTLET
4	000002232	MANIFOLD WATER 3 OUTLET
5	00219105	CTRL, LIQ LEVEL, 240- 1/3HP
6	2002483	RELAY,THERM. TIME DELAY DPSTNC
7	2002523	LAMP IND 250V RED W/3/16 TABS
8	2002543	MOTOR, CARB - 230V, 1/3HP
9	2002733	SENSOR, ELEC. ICE BANK CNTRL
10	2002743	SWITCH,PRESS. 4PSI LOW WATER
11	2002753	PUMP, 100 GPH - S/STEEL
12	2002763	PUMP, 100 GPH-BRASS,FLTR,250 PSI
13	2002893	SWITCH, ROCKER - SPST, 16A
14	2006613	CONTACTOR - 3 POLE 208/240V
15	3001723	PIPE, STAND - 24.25 LG
16	3001873	TANK, CARB - ASSY
17	3002043	TUBE, SS n.312 OD, COIL
18	3002073	TUBE, SS - .375 OD, PLAIN WTR
19	3002083	TUBE, SS - .375 OD, SYRUP
20	3002173	TUBE, SS n.312 OD, COIL
21	4010243	BOOT, MOTOR PUMP
22	4010253	BOOT, MOTOR PUMP
23	5001023	VALVE BALL 3/8 FPTX3/8 FPT BRAS
24	5001183	ELBOW - .375 BARB X .375 MPT
25	5001343	VALVE,SHTFF-1/4 TURN,JG,1/4FPTX3/8 TUBE

NO.	Part Number	Description
26	5001463	VALVE, TGLE RELF 150# 1/8MPT
27	5001613	O-RING, RUBBER - .750 OD X .625 ID
28	5001793	WASHER TAPERED-.50 FLARE-NYL
29	5001803	ADAPTOR,3/8MF X 3/8 MPT S/S
30	5001823	WASHER, TAPERED - .250 FLARE
31	5001833	WASHER TAPERED-.38 FLARE-NYL
32	5001873	BARB-STEM ADPT 1/4BARBX1/4SW
33	5001903	BARB-STEM ELL - 1/4X1/4 SWV S/S
34	5001963	ADAPTER - .250 BARBX.375 MPT
35	5001983	BARB-STEM ADPT 1/2BARBX1/2SW
36	5002033	NUT SWV 1/2 FLARE NP BRASS
37	6052031	BRACKET, HOSE RETAINER
38	6052071	COVER, TOP
39	8251513	VALVE, SHUT OFF 1/4 X 1/4
40	8332023	COUPLING-3/8 FLARE X 3/8 NPT
41	000000579	MOD 50 TXV SERVICE KIT
42	Y0208032	ELECTRODE ASSEMBLY, 10.8", BLACK
43	Y0208031	ELECTRODE ASSEMBLY, 7.9", RED
44	7601431	HEAT SINK TUBE ASM AND CLAMP
45	020001414	CTRL ELEC ICE BANK 230V IHI
46	020001715	PANEL RIGHT SIDE
47	020001716	PANEL FRONT
48	5009036	CLAMP PUMP CARB
49	00213237	MOTOR ASSY
50	7601431	KIT, AGITATOR MTR ASM 25W 230V

# EXPLODED VIEWS

## DRAWING DETAILS

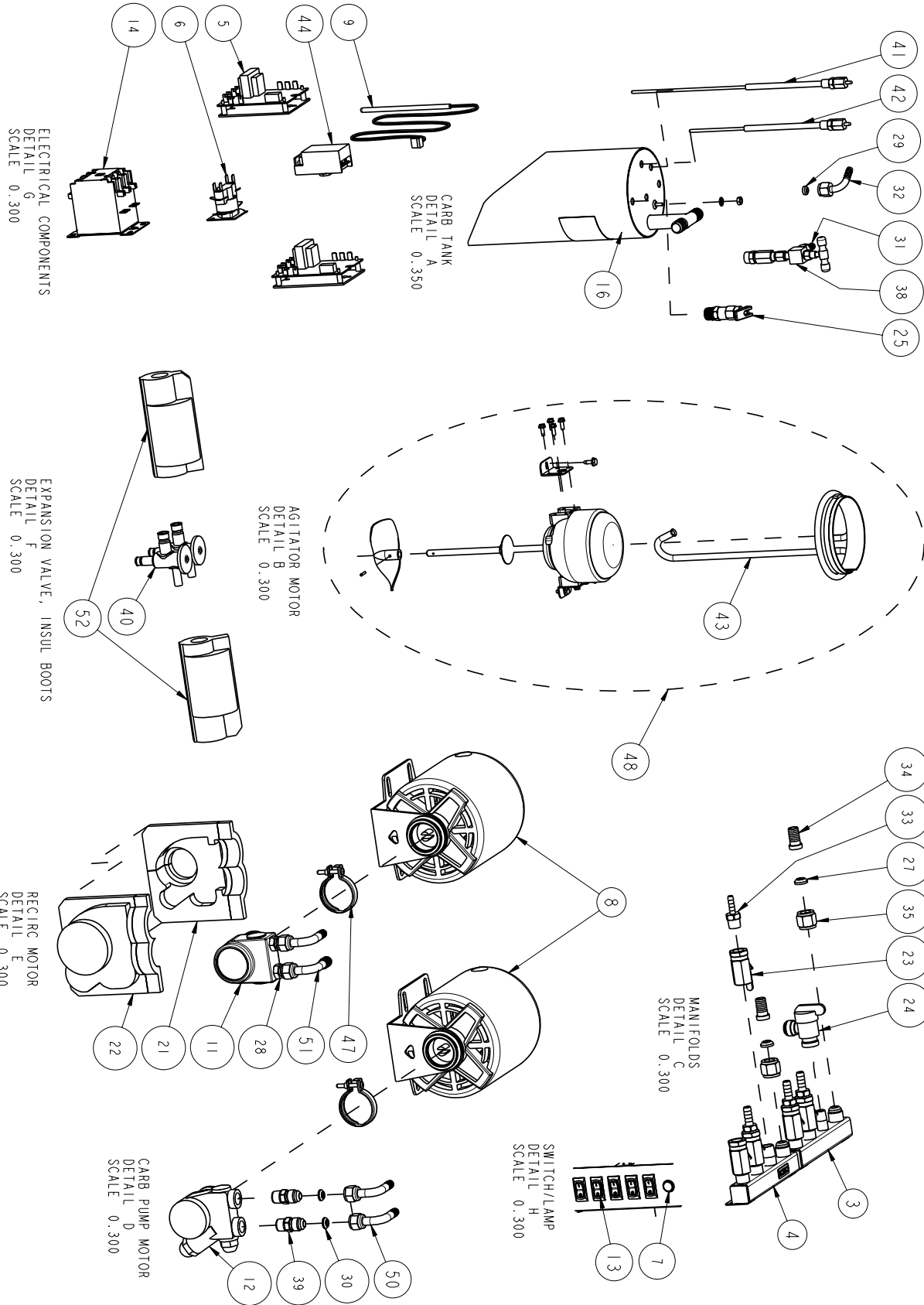

# EXPLODED VIEWS

## AIR SCHEMATIC

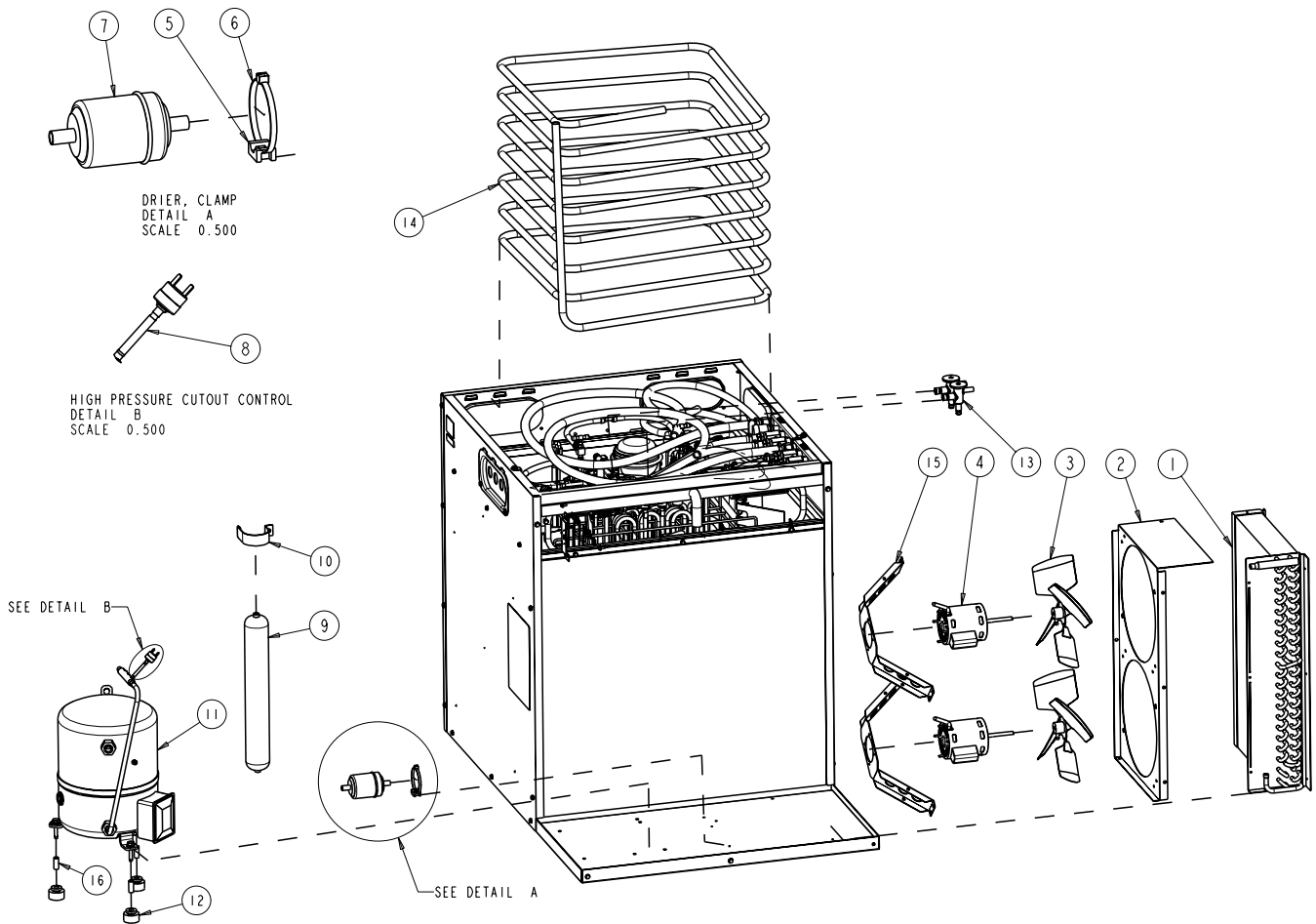

NO.	Part Number	Description	Qty.
1	000001193	CONDENSER AIR 11 X 22	1
2	000001324	SHROUD CONDENSER FAN	1
3	000001425	BLADE FAN	2
4	2008253	MOTOR, FAN 208-230V 50/60HZ	2
5	5650613	MOUNTING BASE, SCREW	1
6	5650351	PLASTIC CABLE TIE 15-1/8 50#	1
7	8253333	DRIER, DANFOSS DML-0535	1
8	2001243	CONTROL, HIGH PRESSURE CUTOUT	1
9	8900353	RECEIVER 2-1/8 OD X 15, 3/8 PORT	1
10	6000541	RECEIVER STRAP	1
11	020001765	KIT COMP. 2.20HP 230V, 3PH, 60HZ	1
12	8503063	GROMMET, RUBBER	3
13	000000285	VALVE THERMAL EXP- DANFOSS	2
14	3001793	COIL EVAP. MOD. 50MA-R 404A 5/	2
15	000001327	BRACKET FAN MOTOR	2
16	8503943	SLEEVE 3/8 ID X 1.031" LG	3

# EXPLODED VIEWS

## WATER SCHEMATIC

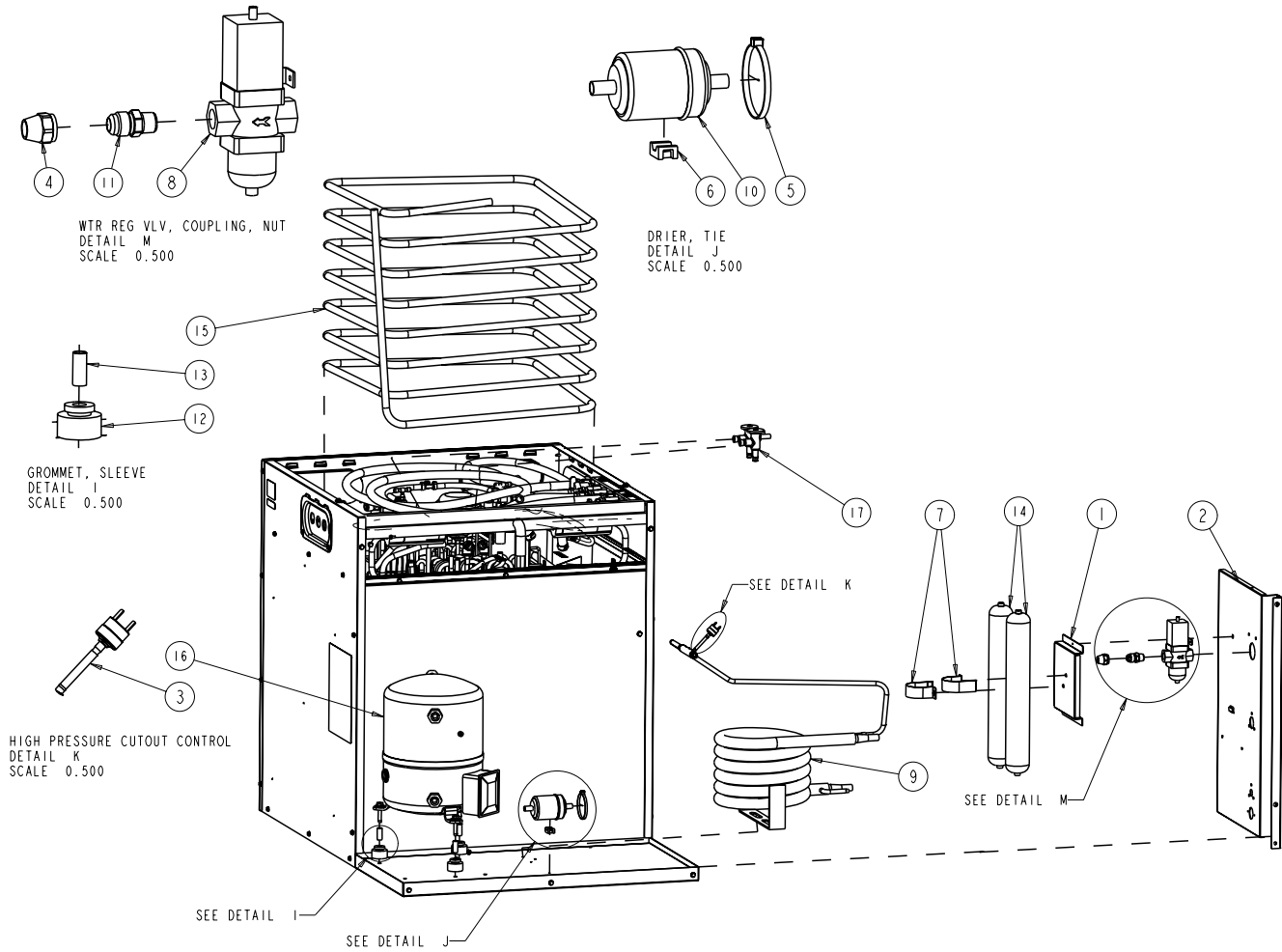

1	000001329	BRACKET RECEIVER	1
2	000001363	PANEL WTR/REM COUPLING	1
3	2001243	CONTROL, HIGH PRESSURE CUTOUT	1
4	5003883	NUT, FLARE - .50	1
5	5650351	PLASTIC CABLE TIE 15-1/8 50#	1
6	5650613	MOUNTING BASE, SCREW	1
7	6000541	RECEIVER STRAP	2
8	8252823	VALVE, WATER REGULATING	1
9	8253033	CONDENSER, WATER	1
10	8253333	DRIER, DANFOSS DML-053s	1
11	8332033	COUPLING-1/2 FLARE X 3/8 MPT	1
12	8503063	GROMMET, RUBBER	3
13	8503943	SLEEVE, 3/8 ID X 1.031 LG.	3
14	8900353	RECEIVER 2-1/8OD X 15, 3/8 PORT	2
15	3001793	COIL EVAP. MOD. 50MA-R 404A 5	2
16	020001765	KIT COMP. 2.20HP 230V, 3PH, 60HZ	1
17	000000285	VALVE THERMAL EXP- DANFOSS	2

# EXPLODED VIEWS

## REMOTE SCHEMATIC

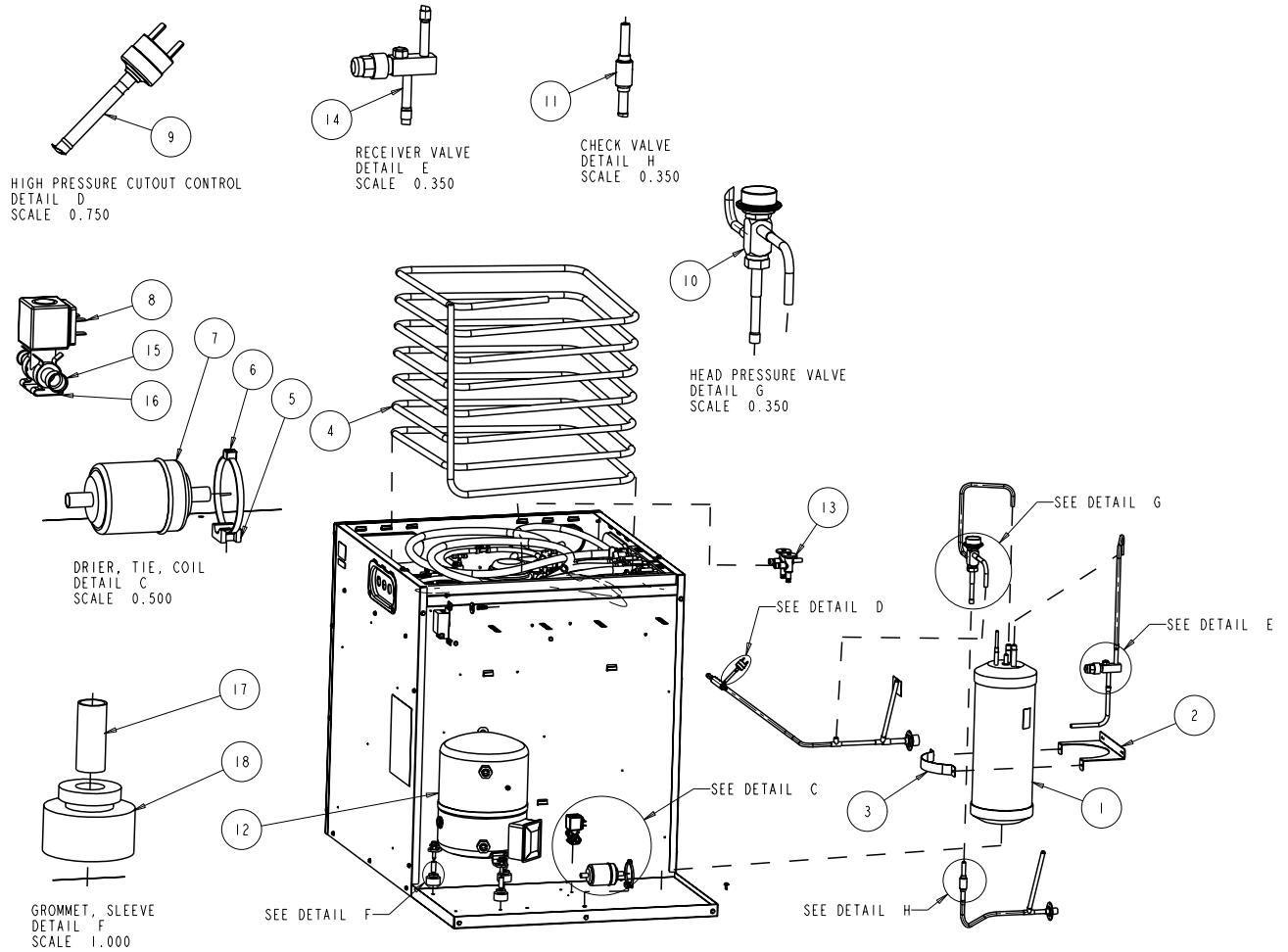

NO.	Part Number	Description	Qty.
1	8900003	RECEIVER, 6.00 DIA X 16.00 LG	1
2	6000561	RECEIVER MTG. BRACKET	1
3	6307214	RECEIVER MTG STRAP	1
4	3001793	COIL EVAP. MOD. 50MA-R 404A 5/	2
5	5650613	MOUNTING BASE, SCREW	1
6	5650351	PLASTIC CABLE TIE 15-1/8 50#	1
7	8253333	DRIER, DANFOSS DML-0535	1
8	2001773	COIL, DANFOSS 208-230V 50/60HZ	1
9	2001243	CONTROL, HIGH PRESSURE CUTOUT	1
10	2002403	VALVE 180PSI 3/8ODF HEAD PRES.	1
11	000001288	VALVE CHECK - .375 ODF	1
12	020001765	KIT COMP. 2.20HP 230V, 3PH, 60HZ	1
13	000000285	VALVE THERMAL EXP- DANFOSS	2
14	8373163	VALVE, SERVICE-RECEIVER	1
15	8251373	VALVE, SOL EVU4 .500IN-.375OUT	1
16	000000805	BRACKET DANFOSS VALVE	1
17	8503943	SLEEVE 3/8 ID X 1.031" LG	3
18	8503063	GROMMET, RUBBER	3

# WIRING DIAGRAMS

## 50M 50HZ MODELS

50HZ

MODELS  
 50MAX04 TS905053-353  
 50MRX04 TS905054-353  
 50MWX04 TS905055-353

50HZ

CAUTION: DISCONNECT POWER BEFORE WORKING ON ELECTRICAL CIRCUITRY.

SEE SERIAL PLATE FOR VOLTAGE

SHOWN IN THE OFF POSITION

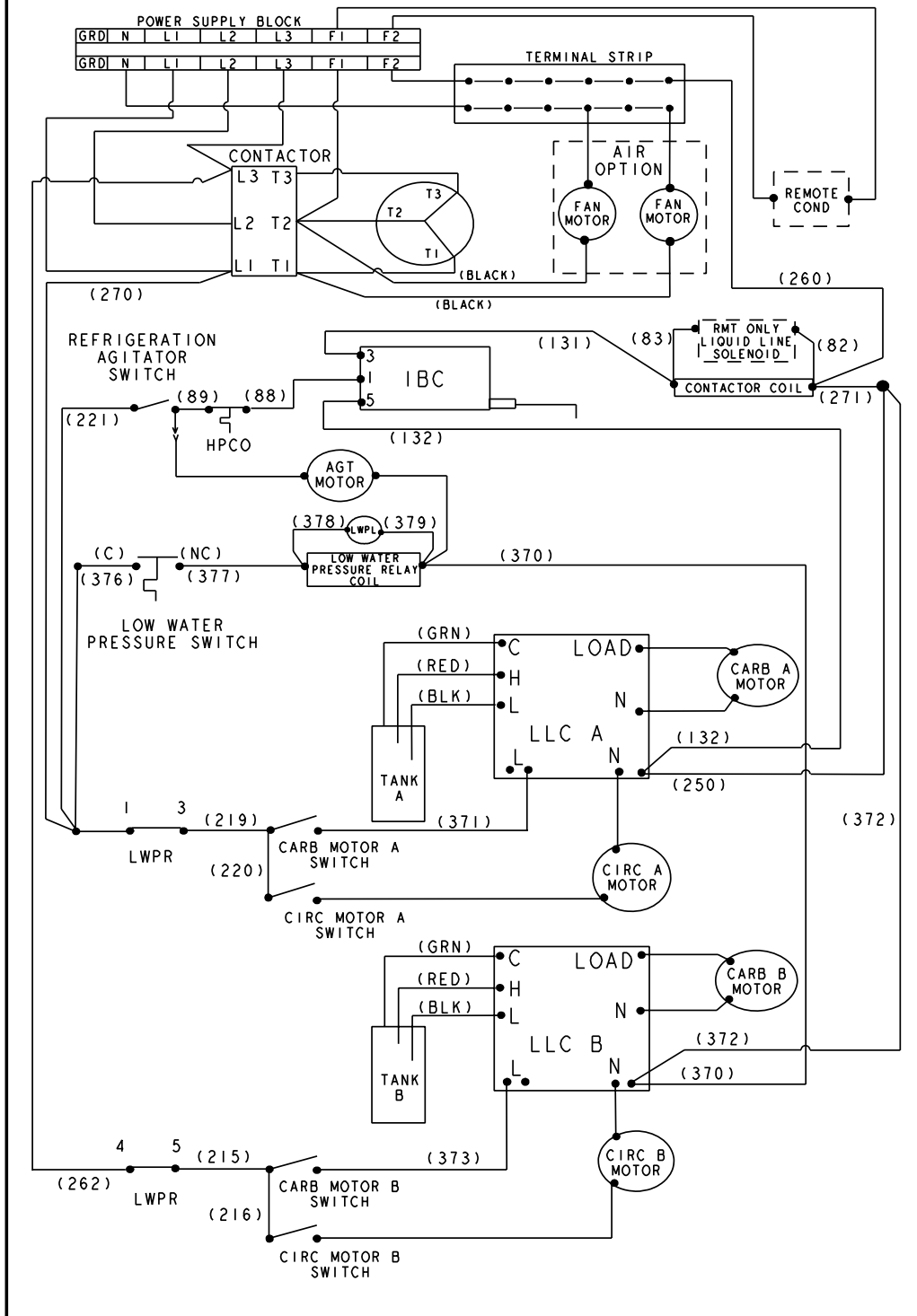

# WIRING DIAGRAMS

## 50M 60HZ MODELS

60HZ

60HZ

MODELS  
 50MA04 TS905050-263  
 50MR04 TS905051-263  
 50MW04 TS905052-263  
 50MR04Q/T TS905046-263

CAUTION: DISCONNECT POWER BEFORE WORKING ON ELECTRICAL CIRCUITRY.

SEE SERIAL PLATE FOR VOLTAGE

SHOWN IN THE OFF POSITION

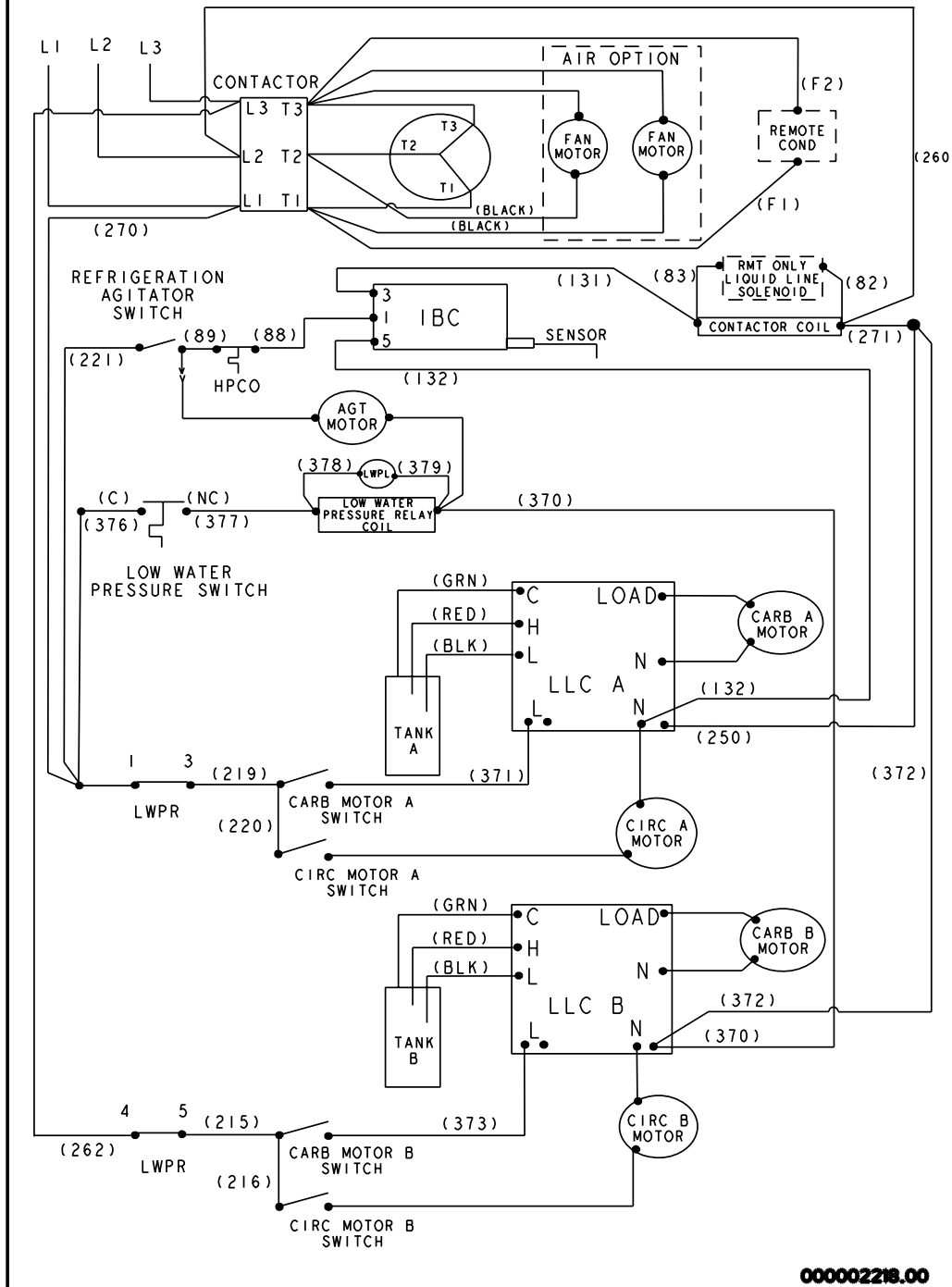

00002218.00



**DO NOT USE**

***Under  
Preventative  
Maintenance***

**Please post this page in front of dispenser when cleaning system.**





# INDEX

---

<b>B</b>	<b>I</b>	<b>R</b>	<b>U</b>
brixing ..... 2	INSPECTION ..... 2	re-charge ..... 15	UNPACKING ..... 2
<b>C</b>	INSTALLATION 7, 8, 9, 10, 11, 12	Relocation ..... 4	<b>W</b>
Carbon Dioxide ..... 4	Installation Date ..... 2	return procedures ..... 2	Warning ..... 4
Cleaning ..... 2	irregularities ..... 2	<b>S</b>	WARRANTY INFORMATION ... 2
CO2 ..... 5	<b>L</b>	SAFETY ..... 4, 5	water-to-syrup ratio. <i>See</i> brixing
CO2 monitors ..... 5	line set ..... 15	sanitizing ..... 5	
<b>D</b>	<b>M</b>	Serial Number ..... 2	
damage ..... 2	MBE ..... 2	service assistance ..... 2	
delivery ..... 2	Model Number ..... 2	Service Personnel ..... 4	
distributor ..... 2	modifications ..... 4	Shipping ..... 4	
<b>F</b>	<b>O</b>	Shipping, Storage, Relocation .. 4	
FOREWORD ..... 2	Operation ..... 4	start-up ..... 4	
	<b>Q</b>	Storage ..... 4	
	Qualified Service Personnel .... 4		



**Multiplex**

645 Park East Blvd, Suite 5 • New Albany, IN 47150  
Tel: 844.724.2273 • Fax: 812.246.7020  
[www.multiplexbeverage.com](http://www.multiplexbeverage.com)

In accordance with our policy of continuous product development and improvement, this information is subject to change at any time without notice.

07-18-07 REV0