

Beermaster Refrigeration Unit

Installation, Use & Care Manual

This manual is updated as new information and models are released.
Visit our website for the latest manual. www.welbilt.com

Safety Notices

As you work on Multiplex equipment, be sure to pay close attention to the safety notices in this manual. Disregarding the notices may lead to serious injury and/or damage to the equipment.

Throughout this manual, you will see the following types of safety notices:

Warning

Text in a Warning box alerts you to a potential personal injury situation. Be sure to read the Warning statement before proceeding, and work carefully.

Caution

Text in a Caution box alerts you to a situation in which you could damage the equipment. Be sure to read the Caution statement before proceeding, and work carefully.

Procedural Notices

As you work on Multiplex equipment, be sure to read the procedural notices in this manual. These notices supply helpful information which may assist you as you work.

Throughout this manual, you will see the following types of procedural notices:

Important

Text in an Important box provides you with information that may help you perform a procedure more efficiently. Disregarding this information will not cause damage or injury, but it may slow you down as you work.

NOTE: Text set off as a Note provides you with simple, but useful, extra information about the procedure you are performing.

Read These Before Proceeding:

Caution

Proper installation, care and maintenance are essential for maximum performance and trouble-free operation of your Manitowoc equipment. Read and understand this manual. It contains valuable care and maintenance information. If you encounter problems not covered by this manual, do not proceed, contact Manitowoc Foodservice Group. We will be happy to provide assistance.

Important

Routine adjustments and maintenance procedures outlined in this manual are not covered by the warranty.

Warning

PERSONAL INJURY POTENTIAL

Do not operate equipment that has been misused, abused, neglected, damaged, or altered/modified from that of original manufactured specifications.

NOTE: SAVE THESE INSTRUCTIONS.

We reserve the right to make product improvements at any time. Specifications and design are subject to change without notice.

Table of Contents (continued)

Section 1

General Information

Read This Manual	1-1
Unit Inspection	1-1
Model Numbers	1-1
How to Read a Model Number	1-1
Accessories	1-1
Special Applications	1-1
Attention: Marine Installations	1-1
Outdoor Applications	1-1
Serial Plate Location	1-2
Warranty Information	1-2

Section 2

Installation

General	2-1
Dimensions and Clearances — All Models	2-1
Remote Condenser	2-2
Safe Installation Dos and Don'ts	2-2
Location Requirements	2-3
Multiplex Chiller Model Selection Chart	2-3
Clearances	2-3
Ratings	2-3
Kitchen Equipment Installer Representative Responsibilities	2-4
Requirements for Refrigeration Units	2-4
Installer Instructions	2-4
Preparation	2-4
Positioning of Refrigeration Unit	2-5
Equipment Placement	2-5
Electrical Connections	2-5
Electrical	2-6
General	2-6
Minimum Circuit Ampacity	2-6
Electrical Requirements	2-6
Specifications	2-6
Grounding Instructions	2-7
Conduit	2-8
Introduction	2-8
Floor Chases	2-8
Overhead Installation	2-10
Basement Construction	2-11

Table of Contents (continued)

Connecting Beer Conduit	2-12
Conduit Kit	2-13
Installing the Conduit Kit	2-15
Beer Restrictor Lines	2-16
Balancing the System	2-17
Determining Restrictor Line Length and Applied Keg Pressure	2-17
Starting Up the System	2-17
Insulating Connections	2-18
Aeroquip Connection	2-18
Condenser and Pre-charged Lines Installation	2-18
Multiplex Remote Condenser Pre-installation Requirements	2-18
Multiplex Pre-charged Refrigeration Lines Pre-installation Requirements ..	2-19
Installing the Multiplex Remote Condenser	2-19
Connecting the Pre-charged Refrigeration Lines	2-20
Preparing Glycol	2-21
Mixing Glycol Solution	2-21
Additional Glycol Circulating Pump and Motor Kit	2-22
Installing the Glycol Circulating Pump and Motor Kit	2-22
Beermaster Dispensing Towers	2-24
Introduction	2-24
Dispensing Tower Template for Beermaster Dispensing Tower	2-24
Beermaster High Pressure CO₂ Regulator (00211500)	2-25
Introduction	2-25
Kit Contents	2-25
Installing	2-25
Beermaster Dual Secondary Regulator Kit (00211400)	2-25
Introduction	2-25
Kit Contents	2-25
Installing	2-25
Beermaster Blenders	2-27
N ₂ /CO ₂ Blender (Single — 00520182, Dual — 00520183)	2-27
Installation Checklist	2-28

Section 3 Operation

Typical System	3-1
How the Multiplex Works	3-2
Start-up	3-2
Placing Equipment in Operation	3-2
Equipment Setup and Close Procedure	3-3
Equipment Setup Procedure	3-3

Table of Contents (continued)

Equipment Close Procedure	3-3
System Calculators	3-4
Beer Pump, System Pressure and Choker Calculator	3-4
Blended Gas Beer System Pressure and Choker Calculator	3-5
Pure CO ₂ Beer System Pressure and Choker Calculator	3-6
Section 4	
Maintenance	
Major Components	4-1
Dispensing Stations	4-1
Beverage Conduits	4-1
Air Compressor	4-1
Refrigeration Unit	4-1
Gas Blender	4-1
CO ₂ Gas Supply	4-1
Scheduled Frequency	4-1
Shipping, Storage and Relocation	4-2
Section 5	
Before Calling for Service	
Checklist	5-1

Table of Contents (continued)

Section 1

General Information

Read This Manual

Multiplex developed this manual as a reference guide for the owner/operator and installer of this equipment. Please read this manual before installation or operation of the machine. A qualified service technician must perform installation and start-up of this equipment, consult **Section 5** within this manual for service assistance.

If you cannot correct the service problem, call your Multiplex Service Agent or Distributor. Always have your model and serial number available when you call.

Your Service Agent _____

Service Agent Telephone Number _____

Your Local Multiplex Distributor _____

Distributor Telephone Number _____

Model Number _____

Serial Number _____

Installation Date _____

Unit Inspection

Thoroughly inspect the unit upon delivery. Immediately report any damage that occurred during transportation to the delivery carrier. Request a written inspection report from a claims inspector to document any necessary claim.



Warning
PERSONAL INJURY POTENTIAL

Do not operate equipment that has been misused, abused, neglected, damaged, or altered/modified from that of original manufactured specifications.

Model Numbers

This manual covers the following models:

Refrigeration Unit
75A04, 75W04, 75R04, 75AX04, 75WX04, 75RX04
175A04, 175W04, 175R04, 175AX04, 175WX04, 175RX04
300A04, 300W04, 300R04, 300AX04, 300WX04, 300RX04,
450A04, 450W04, 450R04, 450AX04, 450WX04, 450RX04

How to Read a Model Number

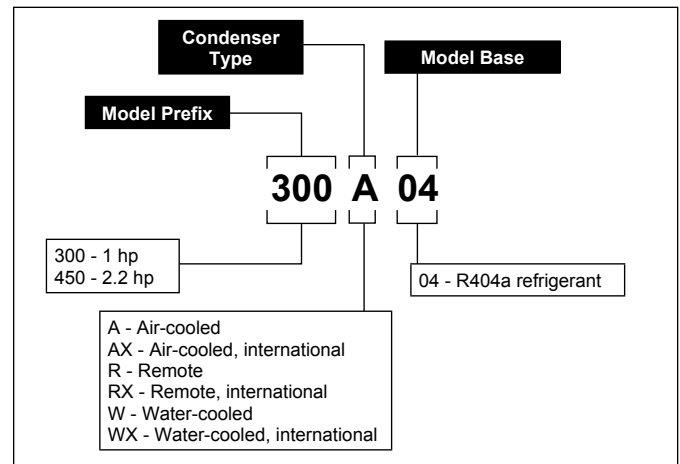

Accessories

Depending on store type and location, various optional equipment (such as CO₂ Panel, water filter kit, water booster kit, etc.) may be added to this system. Install and connect any optional equipment in the desired location according to the installation instructions provided with these kits/equipment.

Special Applications

ATTENTION: MARINE INSTALLATIONS

 **Warning**

This unit is for use on vessels over 66 ft (20 m) in length. This unit must not be installed in the engine space of a gasoline-powered ship.

NOTE: This unit must be secured to the vessel during installation. Models with part numbers beginning with the letters TS are NOT marine listed.

OUTDOOR APPLICATIONS

TS Multiplex Beverage Recirculating units are approved and listed by Underwriters Laboratories (UL). However they are not UL approved for weather exposure applications. These units must be installed in areas where adequate protection from the elements is provided, all other models are ETL listed.

Serial Plate Location

MULTIPLYX
A Manitowoc Company

Manitowoc Ice, Inc.
2110 S. 26th St.
P.O. Box 1720
Manitowoc, WI 54221-1720

REMOTE REFRIGERATION UNIT

MODEL 50MR04 PART NUMBER 78905051-263 SERIAL NUMBER XXXXX 8766

ELECTRICAL RATING: 208-230 VAC 60HZ 3PH

COMPONENT	QTY	VOLTS	AMPERES	POWER
COMPRESSOR	01	208-230	7.1 RLA 40.0 LRA	
FAN MOTOR	01	230	1.0	
CARBONATOR MOTOR	02	230	5.0	
CIRCULATOR MOTOR	02	230	5.0	
AGITATOR MOTOR	01	230	0.4	
SOLENOID	01	230	0.1	

MAX. FUSE OR HACR TYPE CIRCUIT BREAKER: 30A REFRIGERANT: R404A

MINIMUM BRANCH CIRCUIT AMPACITY: 20.4 UNIT CHARGE: 144 OZ

REFRIGERATION DESIGN PRESSURE: HI-500 PSIG LO-250 PSIG

IF A SUPPORT STAND IS USED, USE ONLY MULTIPLYX MODEL: 4450

SYRUP LINE PRESSURE MUST NOT EXCEED 75 PSIG. CHECK INSTRUCTIONS FOR PROPER CO₂ PRESSURE SETTINGS.

FOR USE WITH REMOTE CONDENSER TS0895

NSF c UL US LISTED

Made in USA

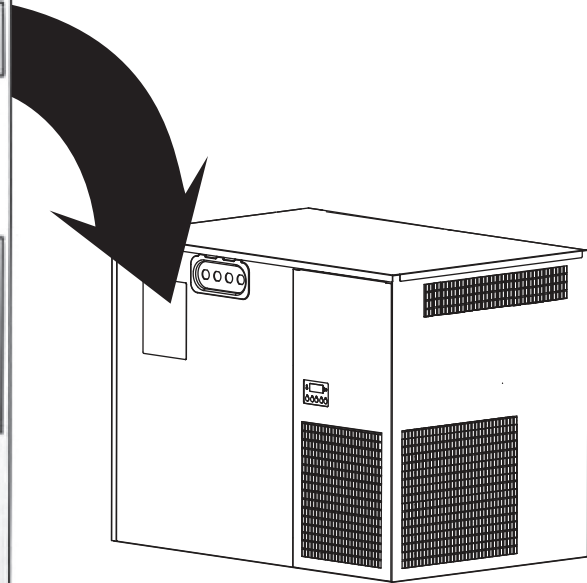

Warranty Information

Consult your local Multiplex Distributor for terms and conditions of your warranty. Your warranty specifically excludes all beverage valve brixing, general adjustments, cleaning, accessories and related servicing.

Your warranty card must be returned to Multiplex to activate the warranty on this equipment. If a warranty card is not returned, the warranty period can begin when the equipment leaves the Multiplex factory.

No equipment may be returned to Multiplex without a written Return Materials Authorization (RMA). Equipment returned without an RMA will be refused at Multiplex's dock and returned to the sender at the sender's expense.

Please contact your local Multiplex distributor for return procedures.

Section 2 Installation

General

- Refrigeration units require stand or 6" (15.2 cm) legs. Refrigeration unit cannot be placed directly on floor.
- Conduit can be run through floor or ceiling chase.

Dimensions and Clearances — All Models

CONDUIT ROUTING PER BEER MASTER MODEL

- For Model 300 Beer Master Chillers conduit can exit left side, back and front of unit.
- For Model 150 Beer Master Chillers conduit will exit left side of unit.
- For Model 75 Beer Master Chillers conduit will exit front of unit.

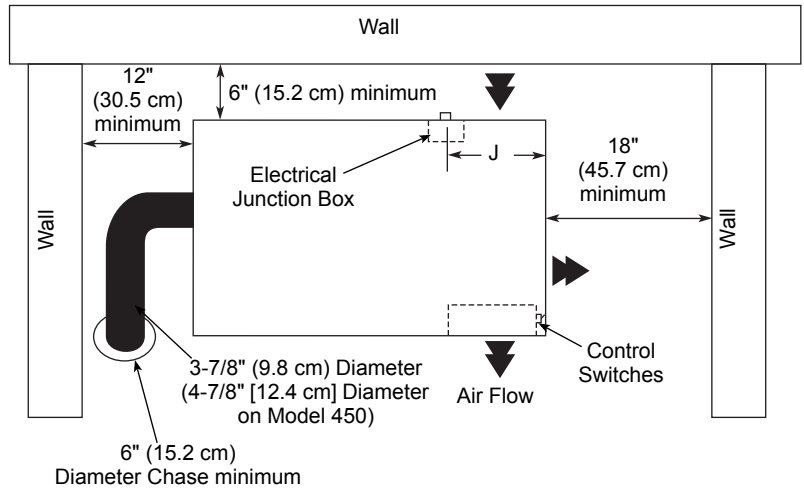

Top View

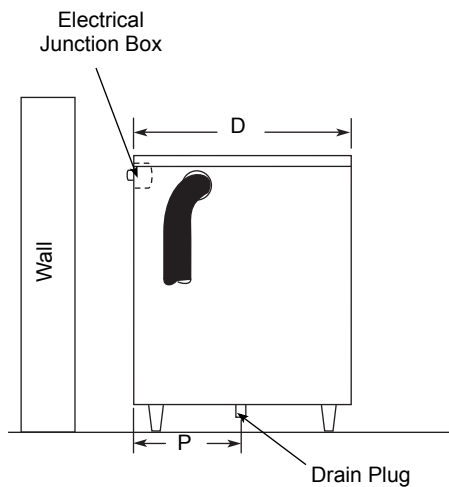

Side View

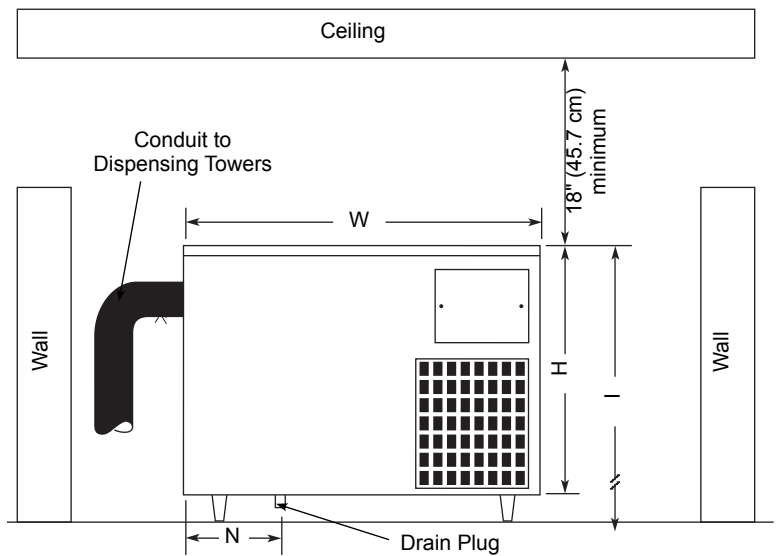

Front View

Model	W	D	H	I (with stand)	J	N	P
75	27 3/4" (70.5 cm)	16 1/4" (41.3 cm)	18 3/4" (47.7 cm)	--	--	19 3/4" (50.2 cm)	5 1/2" (14.0 cm)
150	36 1/4" (92.1 cm)	19 1/2" (49.5 cm)	21 1/2" (54.6 cm)	--	11" (28 cm)	5" (12.7 cm)	9" (22.9 cm)
300	39-3/4" (101 cm)	24-3/4" (62.9 cm)	28-1/4" (72.4 cm)	60-3/4" (154.3 cm)	11" (28 cm)	6" (15.2 cm)	12" (30.5 cm)

Model	W	D	H	I (with stand)	J	N	P
450	42-1/4" (107.3 cm)	28-1/4" (71.8 cm)	32-1/4" (81.9 cm)	66-3/4" (169.5 cm)	11" (28 cm)	8-1/2" (21.6 cm)	14" (35.6 cm)

REMOTE CONDENSER

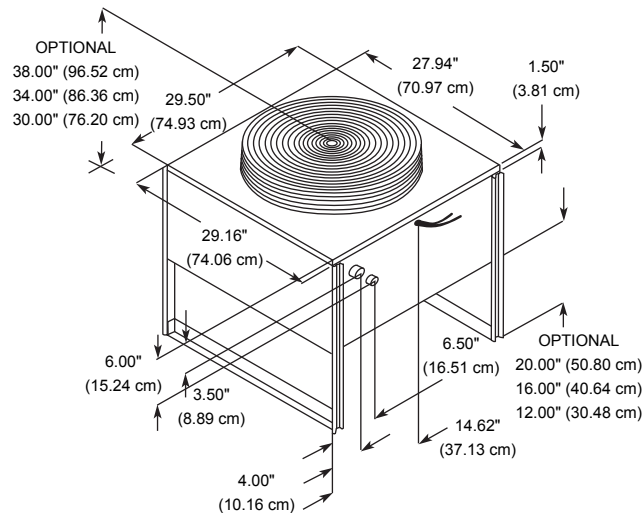

Safe Installation Dos and Don'ts

Warning

Read the following warnings before beginning an installation. Failure to do so may result in possible death or serious injury.

- **DO** adhere to all National and Local Plumbing and Electrical Safety Codes.
- **DO** turn OFF incoming electrical service switches when servicing, installing, or repairing equipment.
- **DO** check that all flare fittings are tight. This check must be performed with a wrench to ensure a quality seal.
- **DO** inspect pressure on regulators before starting up equipment.
- **DO** protect eyes when working around refrigerants.
- **DO** use caution when handling metal surface edges of all equipment.
- **DO** handle CO₂ cylinders and gages with care. Secure cylinders properly against abrasion.
- **DO** store CO₂ cylinder(s) in well ventilated areas.
- **DO NOT** exhaust CO₂ gas (example: syrup pump) into an enclosed area, including all types of walk-in coolers, cellars, and closets.
- **DO NOT** throw or drop a CO₂ cylinder. Secure the cylinder(s) in an upright position with a chain.
- **DO NOT** connect the CO₂ cylinder(s) directly to the product container. Doing so will result in an explosion causing possible death or injury. It is best to connect the CO₂ cylinder(s) to a regulator(s).
- **DO NOT** store CO₂ cylinders in temperature above 125°F (51.7°C) near furnaces, radiator or sources of heat.
- **DO NOT** release CO₂ gas from old cylinder.
- **DO NOT** touch refrigeration lines inside units; some may exceed temperatures of 200°F (93.3°C).

NOTICE: All utility connections and fixtures must be sized, installed, and maintained in accordance with Federal, State, and Local codes.

Location Requirements

MULTIPLEX CHILLER MODEL SELECTION CHART

Model #*	300	450
Line length	up to 300'	up to 450'
Included glycol circulation pump	1	3
Optional glycol circulation pumps	up to 2 additional	one additional
Qty of flavors**	up to 22	up to 32
* Chiller condensing options are available, refer to Condenser and Pre-charged Lines Installation for details. ** Requires maximum number of optional pumps to reach these levels.		

CLEARANCES

Control Side (Right)	18" (45.7 cm)
Connection Side (Left)	12" (30.5 cm)
Back Side	6" (15.2 cm)
Ceiling	18" (45.7 cm)

RATINGS

Model	Evaporator Rating at 20°F (-6.5°C)	Heat Rejection (Max.)
75	2500 BTUH 490 kcal/hr	4500 BTUH885 kcal/hr
150	5150 BTUH 1,159 kcal/hr	8,638 BTUH 1,949kcal/hr
300	9,700 BTUH 2,340 kcal/hr	13,576 BTUH 3,685 kcal/hr
450	14,900 BTUH 3,310 kcal/hr	20,400 BTUH 4,285 kcal/hr

Select a location for the refrigeration unit that meets the requirements of the building plans, local codes, and personnel. The unit must be positioned for free airflow as well as for future service. The following requirements must be met:

- Beverage quality CO₂ gas (bulk or bottled supply) with a minimum 3/8" (.96 cm) line

NOTE: Refer to serial plate on front of refrigeration unit for voltage and amperage specifications. Make all electrical connections at the junction box located at the top rear of unit. Optional equipment may require additional power supplies.

 Warning

Carbon Dioxide (CO₂) displaces oxygen. Exposure to a high concentration of CO₂ gas causes tremors, which are followed rapidly by loss of consciousness and suffocation. If a CO₂ gas leak is suspected, particularly in a small area, immediately ventilate the area before repairing the leak. CO₂ lines and pumps must not be installed in an enclosed space. An enclosed space can be a cooler or small room or closet. This may include convenience stores with glass door self serve coolers. If you suspect CO₂ may build up in an area, venting of the BIB pumps and/or CO₂ monitors must be utilized.

**KITCHEN EQUIPMENT INSTALLER
REPRESENTATIVE RESPONSIBILITIES**

Prior to scheduling Multiplex Equipment installer, the following steps listed below must be completed:

1. Electrical power supply meeting the requirements for the unit to be installed. (See the specification in this section or refer to the unit's serial plate).
2. CO₂ Gas (bulk or bottled supply); minimum 3/8" line.
3. A 120 VAC, 3-wire, 1 Phase, 60 Hz dual wall receptacle for optional electrical equipment (domestic only).

NOTE: Do not schedule the authorized Multiplex Equipment Installer until all of the above have been completed. It will only result in charge-backs to you for the unnecessary trips.

REQUIREMENTS FOR REFRIGERATION UNITS

- Conduit can be run through floor or ceiling chase.
- 60°F (15.6°C) minimum and 105°F (40.5°C) maximum operating ambient conditions.
- For indoor installation only.
- Beer supply can be located on stand or adjacent to refrigeration unit.

Installer Instructions**Important**

The remainder of these instructions is to be completed by an authorized Multiplex Installer.

These equipment instructions are intended to assist qualified personnel in the unpacking, locating and the initial operation of the Multiplex Beverage Equipment Refrigeration Unit.

Important

This publication must be saved for future reference. Read instructions before attempting installation.

PREPARATION

The Multiplex Beverage Equipment Refrigeration Unit is pre-assembled in the factory and requires minimum installation.

For future reference or to be used when ordering parts, record the Model Number, Serial Number, Part Numbers of Unit, Condenser (if remote), Towers, etc., and Date of Installation on the inside of this Manual. Leave manual on site in a safe place. Do not discard manual.

Ambient Location Requirement

This equipment is rated for indoor use only. It will not operate in sub-freezing temperature. In a situation when temperatures drop below freezing, the equipment must be turned off immediately and properly winterized. Contact the manufacturer for winterization process.

POSITIONING OF REFRIGERATION UNIT

Before proceeding with installation, verify that all requirements for roof mounted Remote Condenser Units have been satisfied (if applicable). Refer to the instructions on installing the Remote Condenser supplied with the unit.

If unit is to rest on floor, locate four 6" (15.2 cm) adjustable legs (optional). Screw and tighten legs into the bottom of the refrigeration unit. Set unit in desired location and adjust legs until unit is level and sturdy. If unit is to be mounted on stand, position stand and secure unit to stand. If unit is to be installed on a wall mount bracket, install wall mount bracket and position unit on bracket at this time. Fasten unit to bracket with bolts provided.

EQUIPMENT PLACEMENT

NOTE: All Refrigeration Units must be mounted on either 6" legs or optional stand.

1. Move the stand/refrigeration unit to the designated area and position it near the wall at a distance of at least 6" (15.2 cm) for air circulation in air-cooled units, or at a distance required by local code.
2. Level the stand/unit by adjusting the leg levelers provide on the legs or stand.
3. If unit is equipped with optional stand, lift the Refrigeration Unit onto the stand. Position the unit in the center of the stand. Be sure to orientate the drain of the refrigeration unit with the drain access hole of the stand. Secure with 5/8"-11 x 1" bolts supplied in kit, use two (2) bolts diagonally. Schedule the electrician to connect the electrical service if you have not already done so (refer to Electrical Requirements for requirements listed in these instructions).
4. Mount any optional equipment at this time. Follow the installation instructions for each kit required.

ELECTRICAL CONNECTIONS

 **Caution**

Make sure power supply to unit is turned off.

NOTE: The electrician must refer to the nameplate and wiring schematic on the refrigeration unit for correct electrical requirements. All wiring must comply with all safety codes. Make sure all refrigeration unit power switches are in the OFF position.

1. Remove junction box cover.
2. Route and connect power supply to leads in the electrical junction box at the top rear of the motor compartment.

NOTE: Be sure to connect ground wire(s) to ground screw located on back panel of junction box.

3. Replace junction box cover.

Electrical

GENERAL

 Warning

All wiring must conform to local, state and national codes.

MINIMUM CIRCUIT AMPACITY

The minimum circuit ampacity is used to help select the wire size of the electrical supply. (Minimum circuit ampacity is not the beverage/ice machine's running amp load.) The wire size (or gauge) is also dependent upon location, materials used, length of run, etc., so it must be determined by a qualified electrician.

ELECTRICAL REQUIREMENTS

Refer to Ice Machine Model/Serial Plate for voltage/ampere specifications.

SPECIFICATIONS

Model	Volt/Cycle/ Phase	Minimum Circuit Amps	Breaker	Compressor
75	120/60/1	20.3	25A	1/3 hp
	230/50/1	9.0	16A	.46 kw
150	120/60/1	21.5	30A	12 hp
	230/50/1	10.7	16A	.97 kw
300	208-230/60/1	20.6	30A	1 hp
	230/50/1	20.6	25A	1.9 kW
450	208-230/60/3	25.2	30A	2.2 hp
	230/400/50/3	11.6	20A	2.0 kW

GROUNDING INSTRUCTIONS **Warning**

The beverage/ice machine must be grounded in accordance with national and local electrical codes.

This appliance must be grounded. In the event of malfunction or breakdown, grounding provides a path of least resistance for electric current to reduce the risk of electric shock. This appliance is equipped with a cord having an equipment-grounding conductor and a grounding plug. The plug must be plugged into an appropriate outlet that is properly installed and grounded in accordance with all local codes and ordinances.

 **Warning**

Improper connection of the equipment-grounding conductor can result in a risk of electric shock. The conductor with insulation having an outer surface that is green with or without yellow stripes is the equipment grounding conductor. If repair or replacement of the cord or plug is necessary, do not connect the equipment-grounding conductor to a live terminal. Check with a qualified electrician or serviceman if the grounding instructions are not completely understood, or if in doubt as to whether the appliance is properly grounded. Do not modify the plug provided with the appliance — if it will not fit the outlet, have a proper outlet installed by a qualified electrician.

 **Warning**

When using electric appliances, basic precautions must always be followed, including the following:

- a. Read all the instructions before using the appliance.
- b. To reduce the risk of injury, close supervision is necessary when an appliance is used near children.
- c. Do not contact moving parts.
- d. Only use attachments recommended or sold by the manufacturer.
- e. Do not use outdoors.
- f. For a cord-connected appliance, the following shall be included:
 - Do not unplug by pulling on cord. To unplug, grasp the plug, not the cord.
 - Unplug from outlet when not in use and before servicing or cleaning.
 - Do not operate any appliance with a damaged cord or plug, or after the appliance malfunctions or is dropped or damaged in any manner. Contact the nearest authorized service facility for examination, repair, or electrical or mechanical adjustment.
- g. For a permanently connected appliance — Turn the power switch to the off position when the appliance is not in use and before servicing or cleaning.
- h. For an appliance with a replaceable lamp — Always unplug before replacing the lamp. Replace the bulb with the same type.
- i. For a grounded appliance — Connect to a properly grounded outlet only. See Grounding Instructions.

Conduit

CONDUIT SPECIFICATION CHART

Choose # of Beer Flavors	Conduit Specifications				
	Brewmaster 2 Conduit Part #	Beer Lines	Glycol Lines	Glycol Circuits	Total Lines
2	MC043346	2	2	1	4
3	MC053346	3	2	1	5
4	MC063346	4	2	1	6
5	MC073346	5	2	1	7
6*	MC083346	6	2	1	8
6*	MC103346	6	4	2	10
8	MC123346	8	4	2	12
10	MC143346	10	4	2	14
12	MC163346	12	4	2	16
15	MC193346	15	4	2	19
16	MC203346	16	4	2	20
glycol line**	MC023346	2	2	1	

* To maximize system performance on 6-flavor applications, Multiplex recommends using a 10 line conduit with 4 glycol lines/2 circuits.

** 2-line “glycol only” conduit, used between chiller and keg cooler.

INTRODUCTION

The following instructions will provide information for installing Multiplex Beer Conduit with your Beermaster System. Areas which will be covered include routing the conduit for different bar setups, connecting the conduit at the Beermaster Glycol Chiller, connecting the conduit at the beer cooler, and connecting the conduit at the dispensing stations.

FLOOR CHASES

Before pulling beer conduit through a floor chase, ensure the floor chase contains the following:

- 6" (15 cm) minimum PVC conduit chase
- Chase openings should extend 6" (15 cm) above floor
- Wide sweep elbows (2 ft [0.6 m] radius)
- Chase must be clean and dry — no foreign materials

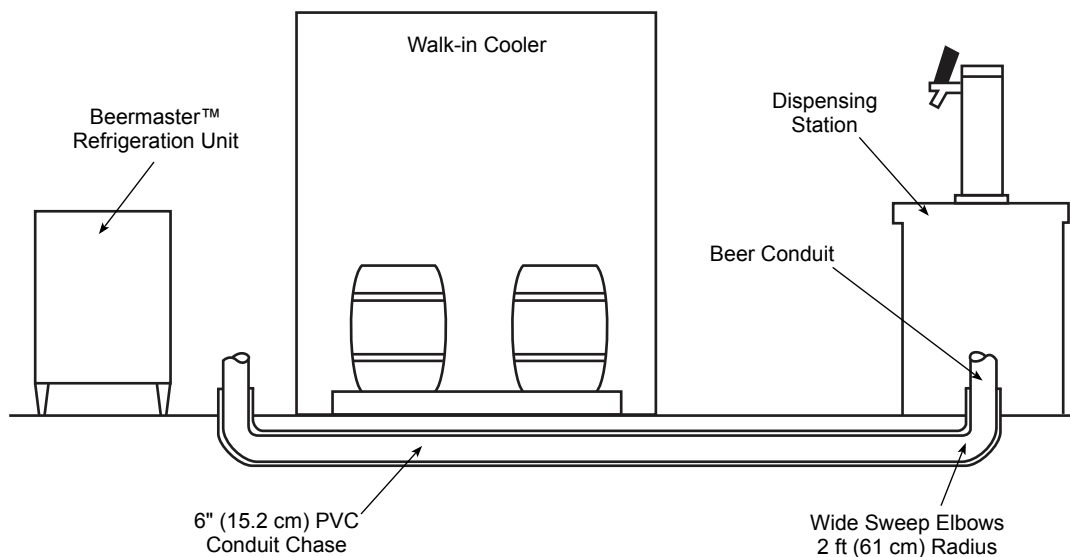

Pulling Conduit Through Floor Chase

1. Determine the most convenient way of routing conduit, starting at the end which offers adequate room for installation. The conduit installation process requires the assistance of at least two (2) qualified personnel.
2. Route the steel fish tape through chase opening. Push fish tape through entire chase until it appears at opposite end.
3. Locate an appropriate length of rope and tie to end of fish tape (end which was routed through chase in step 2). Approximately 2 ft (0.6 m) from steel fish tape/rope connection, secure a swab to rope (use mop heads or a bundle of rags for swab).
4. Pull end of fish tape from starting point through chase with rope and swab. The swab will clean any construction materials, moisture, or debris that may exist in floor chase. Continue to swab the chase until the swab exits the chase clean and dry.
5. After floor chase has been cleaned, remove steel fish tape and swab from rope. Locate bundle of beer conduit and unspool conduit to allow unrestricted feed during installation process.
6. Locate rope through floor chase opening and connect to proper end of beer conduit.

NOTE: The beer conduit is designed to be pulled through floor chase in the direction of arrows printed on conduit.

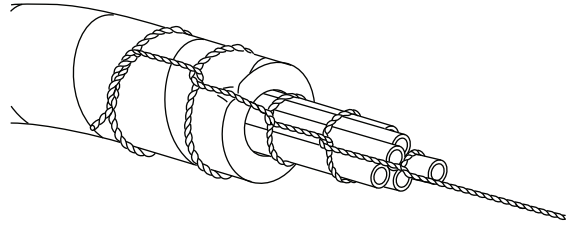

7. After rope has been connected, tape end of conduit, including rope, and form conduit end to a point (see figure above). Tape will ensure that no contaminants enter conduit tubes during installation.
8. Place pointed end of the conduit through chase opening. While one person pushes the conduit through chase, another person should be pulling the conduit through the chase with rope at the opposite end.
9. Once the conduit has been routed through the chase, pull enough conduit through the openings to ensure an adequate supply at each end of the chase for connections.

OVERHEAD INSTALLATION

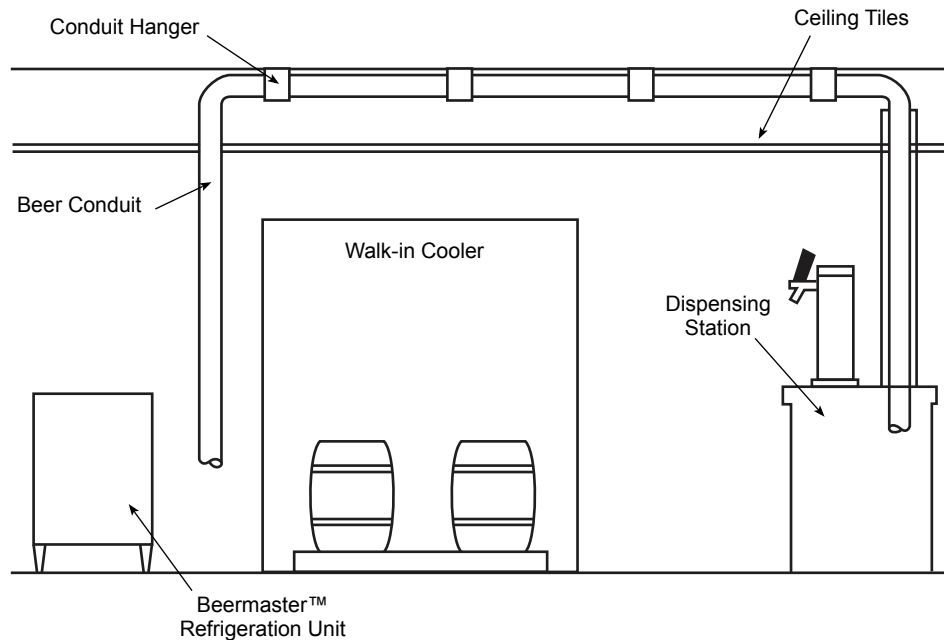

Refer to the figure above for the following:

1. Determine the correct location for routing the beer conduit. Be sure to avoid heat ducts, hoods, grills, or any sharp objects that may exist above drop ceiling tile.
2. Unspool the beer conduit to allow unrestricted feed.
3. Route the conduit above ceiling tiles and connect to ceiling and/or pipes using the appropriate conduit hangers. Be sure the conduit is suspended above ceiling tiles, not lying on the tiles. Care should be taken when determining appropriate method of handing conduit securely. Hangers must not crush or pinch insulation. This will reduce cooling efficiency.
4. Once the conduit has been routed, ensure an adequate supply of conduit is provided at each end to make all connections.

BASEMENT CONSTRUCTION

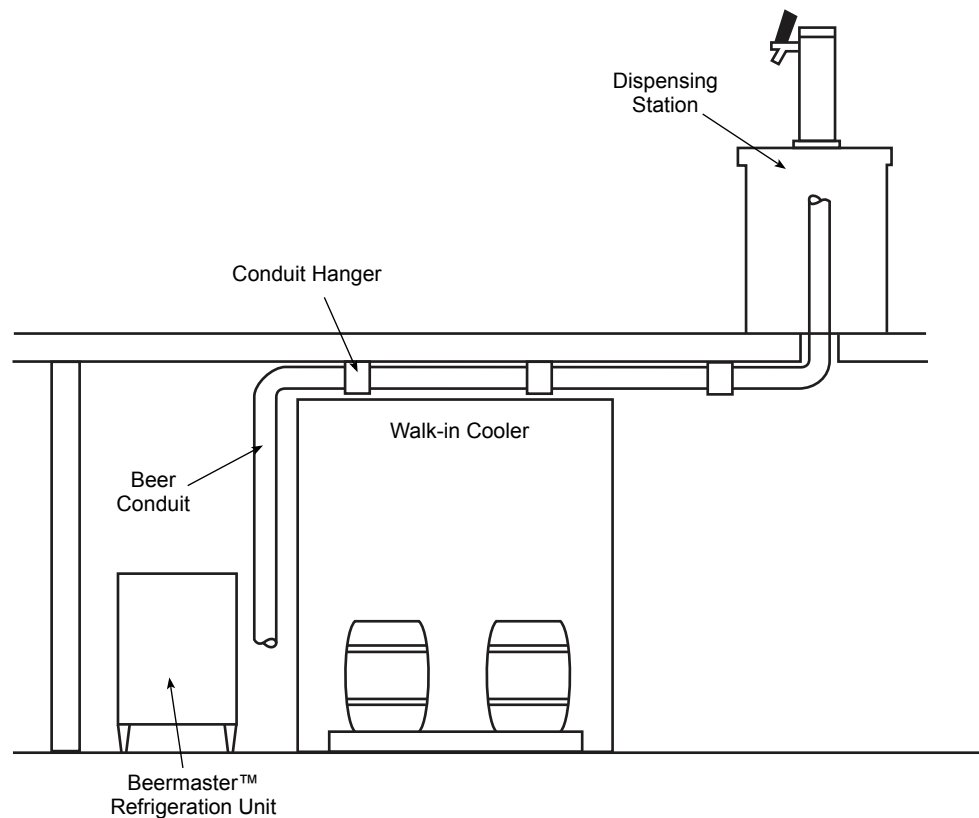

Refer to the figure above for the following:

1. Unspool the beer conduit to allow unrestricted feed during installation process.
2. Route the conduit up basement wall and secure with appropriate conduit hangers.
3. After routing the conduit up the basement wall, route conduit overhead on the basement ceiling. Connect to the basement ceiling using appropriate conduit hangers.
4. Once the conduit has been routed, ensure an adequate supply of conduit is on hand to make all connections.

CONNECTING BEER CONDUIT

Before connecting the beer conduit at the walk-in beer cooler and beer towers, ensure an adequate length of conduit is being supplied to make proper connections.

⚠ Caution

Only an approved cutting tool should be used to cut polyethylene tubing. The cutting tool should contain a razor sharp cutting blade so that the tubing will not be crushed when cutting. A razor blade knife or butterfly tubing cutter is sufficient (see figures). Multiplex packs a butterfly cutter with each Beermaster Glycol Chiller.

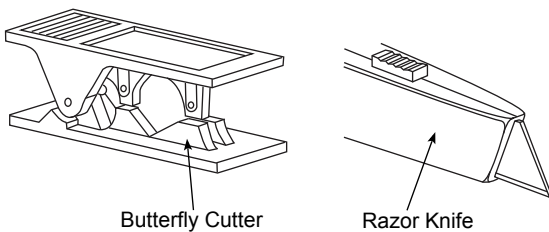

1. Locate the lines of the beer conduit routed to the Beermaster Glycol Chiller.
2. Using an approved cutting tool, cut the beer conduit insulation along the top side while peeling insulation back at the same time.

NOTE: Glycol circuit is a pair of lines; one blue and one red. The blue line is the discharge or supply line. The red line is the return line.

3. Locate the return glycol supply lines of the beer conduit and connect to the corresponding John Guest fitting on the Beermaster Glycol Chiller.
4. Locate the discharge glycol supply lines of the beer conduit and connect to the corresponding John Guest fitting on the Beermaster Glycol Chiller.
5. Locate the glycol lines in the main conduit. Connect the glycol lines of the beer unit to walk-in cooler conduit to the glycol lines of the main beer conduit.
6. Locate the beer and glycol supply lines at the dispensing station. Connect each beer line, incoming glycol line, and outgoing glycol line to the appropriate John Guest fitting at the dispensing station.

NOTE: The 3/8" I.D. poly line used in the beer conduit is thin wall tubing. Barbed fittings should not be used. The usage of barbed fittings causes thin wall tubing to split or crack and leaks will result.

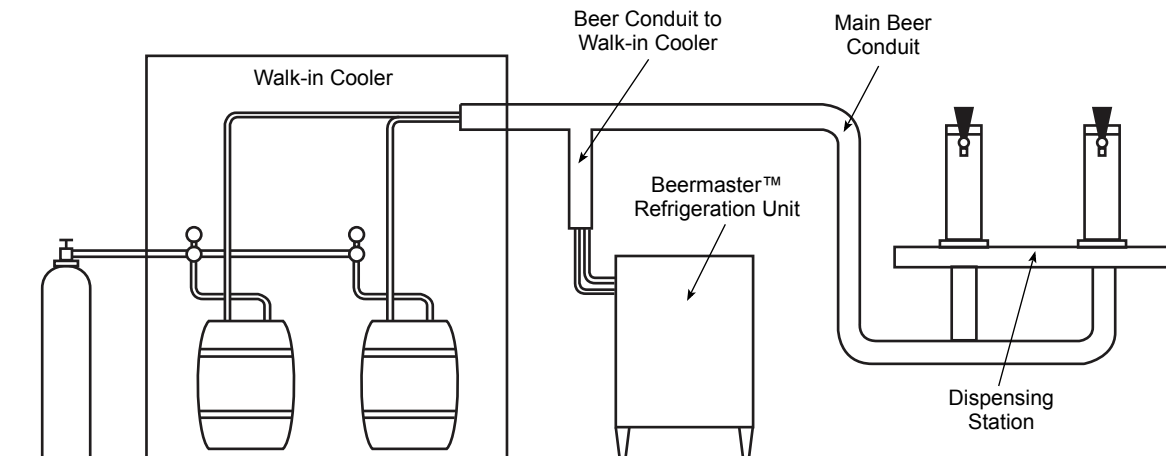

CONDUIT KIT**General**

The following instructions will cover installation procedures required for properly connecting each component of the Beermaster system. These instructions also contain the necessary information required for; calculating restrictor line length, required regulator operating pressures and start-up procedures. It is recommended that before proceeding with these instructions you ensure that each of the following items have been properly installed. Items listed in suggested order of installation:

1. Glycol Chiller Unit
2. Dispensing Towers
3. Secondary Regulator Kits
4. Beer Conduit
5. High Pressure CO₂ Regulator Kit
6. Blender Kit or Beer Pumps
7. Air Compressor Kit (optional)
8. Low CO₂ Alarm Kit

Once the above items have been installed, the following instructions can be completed.

NOTE: Your system may not include each item.

Kit contents**Four (4) and Seven (7) line conduit kits**

- Three (3) Return bends
- Eight (8) Elbows
- 29 Unions
- Five (5) Tail pieces
- Five (5) Beer nuts
- One (1) 60 ft of PVC tape
- One (1) 60 ft of foil
- One (1) Spanner wrench

10 and 14 line conduit kits

- Four (4) Return bends
- 15 Elbows
- 42 Unions
- Eight (8) Tail pieces
- Eight (8) Beer nuts
- One (1) 60 ft of PVC tape
- One (1) 60 ft of foil
- One (1) Spanner wrench

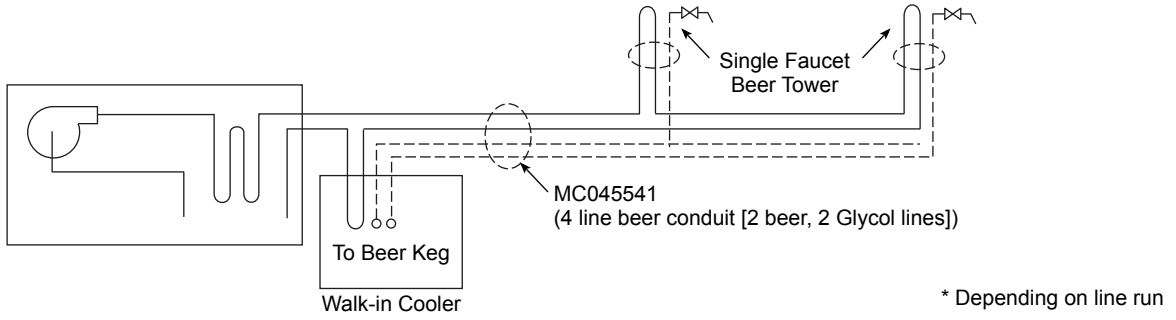

Single Conduit, Two Beer System

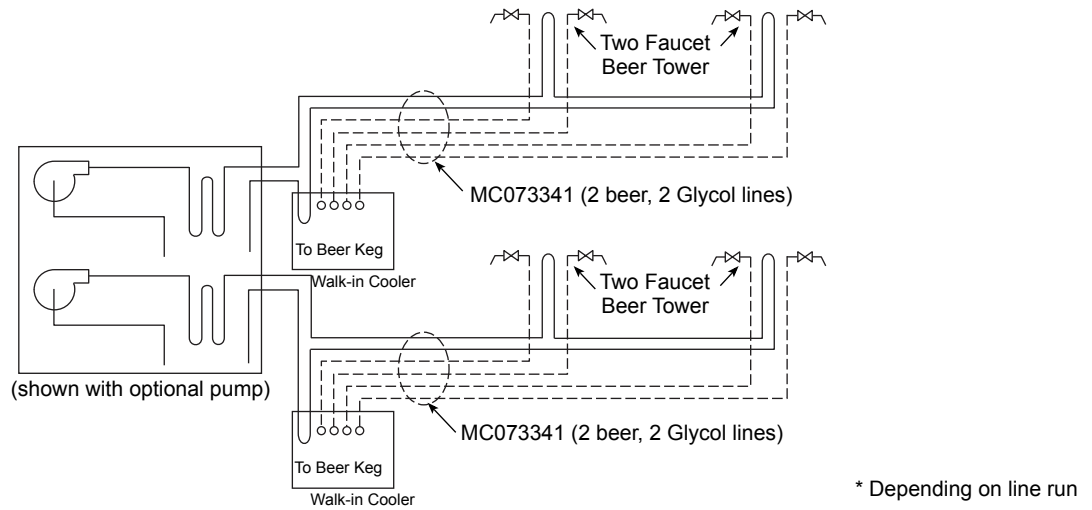

Dual Conduit, Eight Beer System

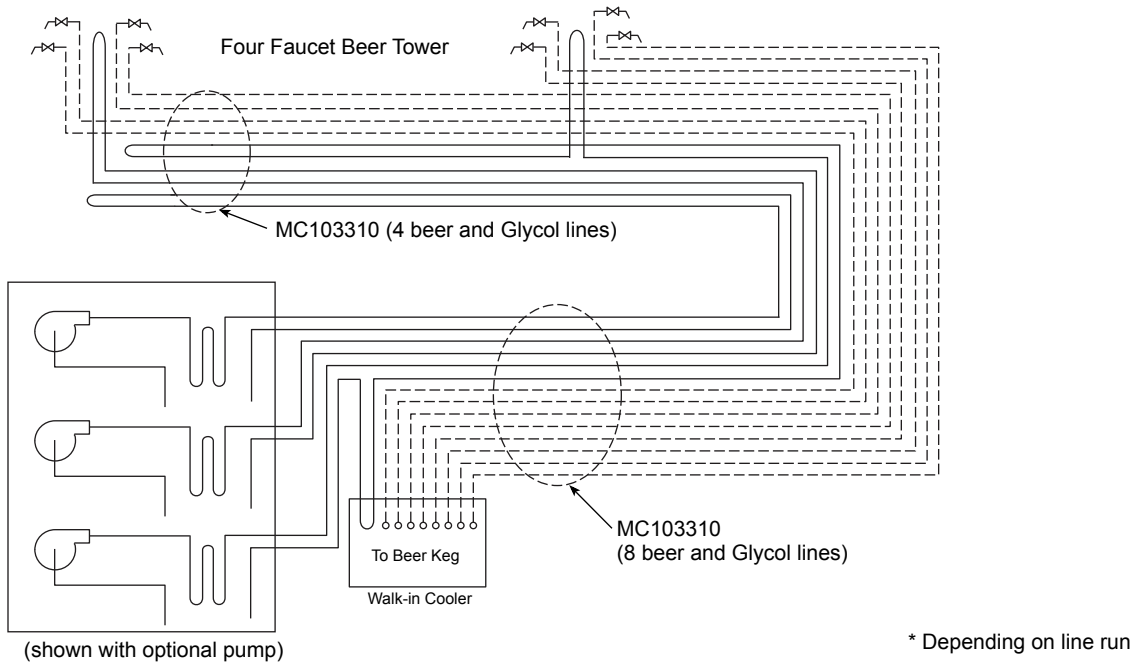

Single Conduit, Eight Beer System

INSTALLING THE CONDUIT KIT

Connections Preview

Review the three previous illustrations to determine which best illustrates your particular installation. Consider the following while examining the drawings:

Beer conduits have been designed to achieve the proper cooling of each encased beer line. In order to function properly, you must follow these guidelines:

Up to eight line conduit:

- six beer maximum, one glycol circuit (two lines)

Ten and over line conduit:

- two glycol circuits (four lines)

To ensure colder dispensing temperatures, glycol should flow directly to the dispensing towers before returning to the remote Glycol Chiller Unit. After examining the drawings determine the desired glycol circuit to be achieved and illustrate on paper for referral. Do the same for the assignment of the beer supply lines.

Connecting the Glycol Chiller to the Walk-in Cooler or Main Beer Conduit

1. Route the glycol conduit(s) from the Beermaster Glycol Chiller to the point of connection on the main beverage conduit(s). This connection could be done in the walk-in cooler or at any desired location along the length of the main beer conduits.
2. Identify the proper glycol lines within the glycol conduit(s) at the Beermaster Glycol Chiller, cut to length and insert into the appropriate John Guest bulkhead fitting(s) found on the side panel of the Beermaster Glycol Chiller as shown below.

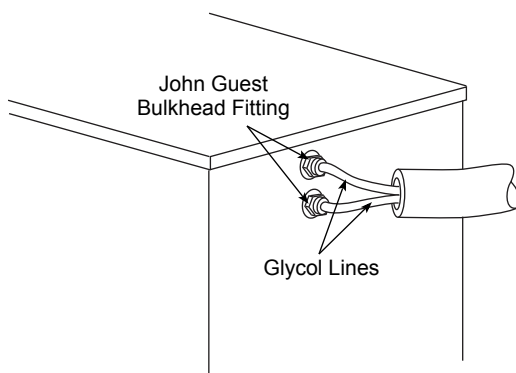

3. At the walk-in end of the conduit(s), peel back the insulation from the beer conduit and identify the appropriate glycol circuit and lines to be connected (blue and red). Cut glycol lines and secure to the appropriate elbow or union connections that are best suited for connection with the beer conduit.

Connecting Main Beer Conduit at Walk-in Cooler

1. At the top of each beer wall bracket fitting, found on the dual secondary regulator, secure a Beer Nut, John Guest adapting tail piece, washer, and 1/2" John Guest union (see the following image).
2. Identify the appropriate beer lines to be connected to each of the wall bracket fittings, cut to length and insert into the proper John Guest 1/2" connector as shown below.

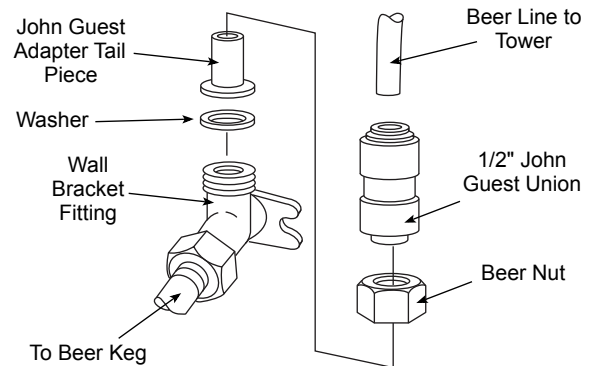

Connecting Beer Conduit to the Tower

Glycol lines in

1. Peel the insulation back from the end of the beer conduit to expose all lines. Locate the appropriate glycol circuit lines, cut to length and attach a 1/2" John Guest union to each line (see the "Tower Connections" image).
2. Attach the opposite end of each 1/2" John Guest union to the 1/2" adapter located at the base of the dispensing tower.

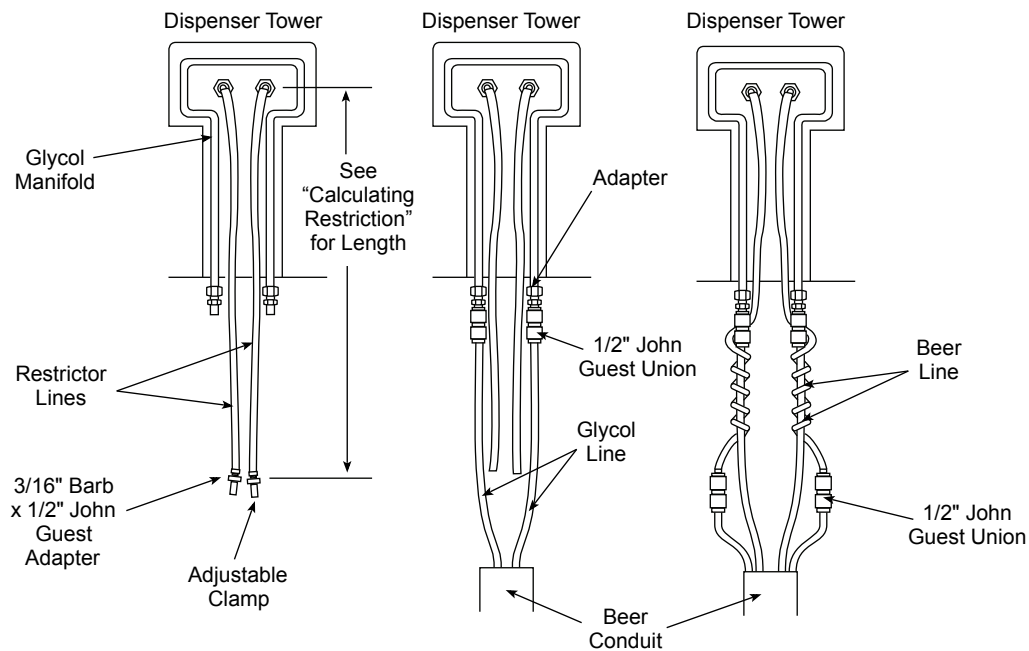

Tower Connections

NOTE: If conduit contains more than one glycol circuit it may be necessary to attach U-bends for each of the additional circuits. Use a 1/2" U-bend quick connect fitting or the U-bend can be built by attaching two (2) 1/2" John Guest elbows to one another by means of a 2" length of 1/2" tubing.

BEER RESTRICTOR LINES

1. Refer to the section on "Balancing the System" in this manual for determining the required length of restrictor line. Calculate the required length for each faucet. Cut each restrictor line to the calculated length and carefully insert the 3/16" Barb x 1/2" John Guest adapter and clamp securely with the adjustable clamps provided (see the "Tower Connections" figure).
2. Identify the beer line to be connected to each of the appropriate restrictor line, cut the beer lines to length and attach a 1/2" John Guest Union to each. Neatly wrap the excess restrictor line securely around the glycol supply lines to ensure good heat exchange. Connect the adapter from each restrictor to the 1/2" connector of each of the appropriate beer lines.

Connecting Main Beer Conduit to Branch Beer Conduit

1. At the required point of connection carefully split open and fold back the insulation on the main beer conduit and identify the correct set of glycol lines (circuit) to connect to the branch beer conduit. Cut the glycol line(s) and attach the appropriate 1/2" elbow or union connections that are best suited to connecting with the main beer conduit (see the "Main Beer Conduit Connections" figure).
2. Peel the insulation back from the end of the branch beer conduit to expose all lines. Locate the glycol circuit lines, cut to length and insert each line into the open end of the previously attached 1/2" connectors at the main beer conduit (see the "Main Beer Conduit Connections" figure).
3. Locate the appropriate beer line(s) in the main beer conduit to be connected to the branch conduit. Cut desired beer line(s) long so that they can be pulled back and then routed in a smooth curve into the branch conduit. Attach appropriate beer line(s) from main beer conduit to beer line(s) in branch beer conduit with 1/2" John Guest Union(s).

⚠ Caution

To avoid agitation use only straight unions when splicing beer lines.

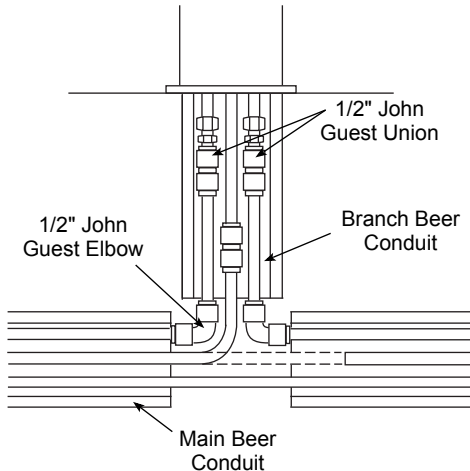

Main Beer Conduit Connections

Balancing the System

DETERMINING RESTRICTOR LINE LENGTH AND APPLIED KEG PRESSURE

In order to ensure a proper, foam-free, beer flow from each faucet, the following instructions and calculations must be completed. Use the formulas found in this section to determine the required restrictor line length and applied keg pressure needed for each beer line. In order to complete these calculations the following information will be needed:

- Brands of beer to be dispensed.
- Temperature of the Walk-in Cooler (default 38°F [3.3°C]).
- Altitude (distance above sea level).
- Total line length for each beer line.
- Overall lift or drop for each beer line.

To determine the appropriate Applied Keg pressures and Restrictor Line Lengths see attached work sheets.

1. First determine which brands of beer will be dispensed at which faucet. Use one work sheet to record data for each faucet.
2. Determine keg temperature at cooler.
3. Determine the type of push for the beer to determine which work sheet to use to calculate flow of beer.
4. Follow the instructions for that particular work sheet.

STARTING UP THE SYSTEM

Before Starting Up the System

Each of the steps below should be done 24 hours prior to the tapping or dispensing of any beer.

1. Place all kegs in a walk-in cooler at 36°F to 38°F and allow them to temper properly.
2. Turn ON the Beermaster Glycol Chiller circulating glycol pump(s).
3. After leak testing all glycol and beer supply lines, wrap the lines firmly with foil (to ensure a good heat exchange) and then insulate all lines; to ensure a minimum of 1" insulation over all areas of exposed beverage line.
4. After glycol has circulated through system for approximately one hour, remove the strainer from the glycol bath. Flush the strainers clean with fresh water and reinstall.

Pressure Setting and Start-up

1. Adjust the primary CO₂ regulator to 40 PSI and secure the lock nut.
2. If a blender is utilized proceed with adjustments provided with blender kit.
3. Adjust the secondary regulators. It is recommended that when applied keg pressures exceed 20 PSI the secondary regulators be adjusted 2 PSI below the calculated pressure. If more pressure is required after tapping keg, increase as needed.
4. Tap the kegs and proceed to draw beer from each valve one at a time. Ensure each brand is properly drawing before proceeding to the next. The proper flow rate for beer at each valve is 2 ounces per second. Beer should be flowing clear with a full flow from the dispensing faucet (a considerable amount of dispensing may be needed).
5. Secure all secondary regulator lock nuts and complete the information label, identifying the product and its applied keg pressure for each appropriate regulator.
6. Instruct operator on proper maintenance and operating requirements.

INSULATING CONNECTIONS

1. Make sure all exposed lines are well insulated on towers to conduit, conduit junctions, refrigeration unit to conduits.
2. To insulate the above, use the leftover conduit sections and tape.
3. Cut the conduit sections to fit snugly over the exposed lines and fittings. A little extra time spent doing a thorough job initially will eliminate a call back in several days to make corrections.

NOTE: Do not inject foam material directly on the connections where the tubing connects to the barb fittings or directly on poly tubing.

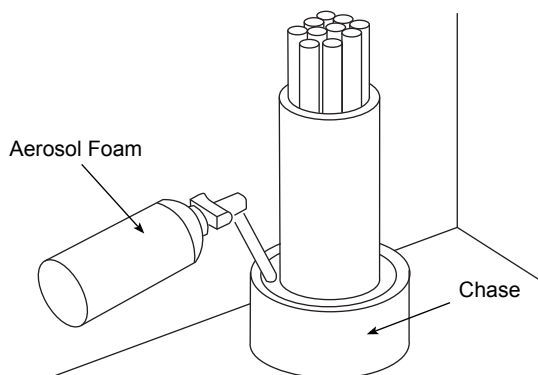

4. The can of foam is to be used to fill the openings between the conduit insulation and the inside diameter of the floor chases. The purpose is to provide an air tight seal at the floor level to prevent foreign matter from entering the chases. Please read the foam manufacturer's instructions carefully. We recommend using the adapter with the right angle extension.
5. Insert the adapter into the openings approximately 1" to 2" (2.5 to 5.1 cm) while depressing the adapter.
6. Move the extension around throughout the area where the foam is to be placed. Do not over fill, allow room for expansion. If the chase opening is too deep insert a section of the leftover conduit insulation in the opening prior to using the foam insulation.

Aeroquip Connection

1. Lubricate male half diaphragm and synthetic rubber seal with refrigerant oil.
2. Thread male coupling to its proper female half by hand to ensure proper mating of threads.
3. Use proper wrenches (on coupling body hex and its union nut) and tighten union nut until coupling bodies "bottom".

NOTE: You must use a wrench on the body to keep the body from turning while tightening the nut with the second wrench. If the body turns excessively, the piercing seal will be damaged.

4. Use proper wrenches to tighten an additional 1/4 turn (90°). This final 1/4 turn is necessary to ensure the formation of a leak proof joint. Alternately, use a torque wrench to tighten the 1/2" coupling to 40 ft-lbs and 3/8" fitting to 11 ft-lbs.
5. Leak check all your connections. If you detect any leaks, repair and recheck.

Condenser and Pre-charged Lines Installation

Before proceeding with installation, verify that all requirements for roof mounted remote condenser units (if applicable) have been satisfied. If unit has a remote condenser, refer to the instructions on installing the remote condenser supplied with the condensing unit and refer to the section on installation of remote refrigeration line sets.

Important

If you are installing a remote unit, there is a refrigeration king valve located behind the compressor. This valve must be back seated prior to starting the compressor. Failure to do so will short cycle and may damage the compressor.

MULTIPLEX REMOTE CONDENSER PRE-INSTALLATION REQUIREMENTS

1. Installation and maintenance are to be performed only by qualified refrigeration personnel. These technicians must have EPA certification (USA), are familiar with local codes and regulations, and are experienced with this type of remote refrigeration equipment.
2. As a condition of the warranty, the check, test and start-up procedure must be performed by qualified personnel. Because of possible shipping damage, check both the condensing unit and refrigeration unit(s) for refrigerant leaks.
3. If the refrigeration unit is located on a roll out platform, you must coil up to one round between the back of the stand and the wall. This allows pull out of the refrigeration unit for servicing.
4. If the refrigeration unit is located in a stationary location, you must remove excess refrigeration tubing as described below.

MULTIPLEX PRE-CHARGED REFRIGERATION LINES PRE-INSTALLATION REQUIREMENTS

- Both the discharge and liquid remote condensing lines must be kept to a minimum distance for maximum performance. All Multiplex systems are capacity rated to 100 ft (30.5 m) tubing distance between the compressor and condenser.
- Any vertical rise 25 ft (7.62 m) or greater must have a manufactured or installed trap (bend), in the discharge refrigeration line from the compressor to the remote condenser. A trap is necessary for every additional 25 ft (7.62 m) vertical rise. When excessive vertical rise exists, this trap allows oil to reach the condenser and return to the compressor.
- The easiest method to create a trap is to bend the tubing (smoothly, no kinks) into the trap form.

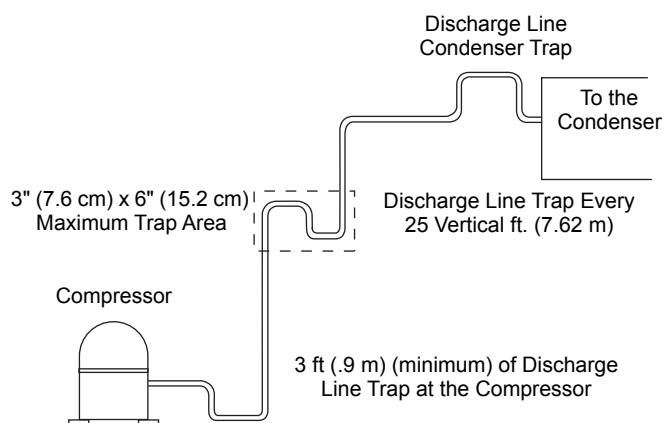

- The trap(s) must be of minimum height of 3" (7.6 cm) and a width of 6" (15.2 cm) to minimize oil accumulation. The traps can also be bent out of the refrigeration tubing. Carefully bend the tubing down 12", and then sweep the tubing back up.
- It is critical that the Multiplex remote condensing line size specifications for the specific model be maintained. The specifications are 1/2" discharge and 3/8" liquid lines.

INSTALLING THE MULTIPLEX REMOTE CONDENSER

The Multiplex remote condensing units have a 208-230 Volt, 50/60 HZ, 1 PH fan motor that includes a permanent split capacitor and internal overload protection. The electrical wires from the refrigeration unit wire to the condenser. The electrical installation must be in accordance with local codes, National Electrical Code and regulations.

- Determine a position for installation that will allow access for maintenance and is free from obstruction. Verify hot air discharge from other condensers does not interfere with the inlet of this condenser.
- Install the four legs to the sides of the condenser using the mounting bolts provided.
- The General Contractor or Owner must secure two treated lumber 4" x 4" x 36" (or longer). You may then mount the remote condenser to the treated lumber.
- The General Contractor or Owner must install a 3" pitch pot in the roof. Then seal for weather protection.

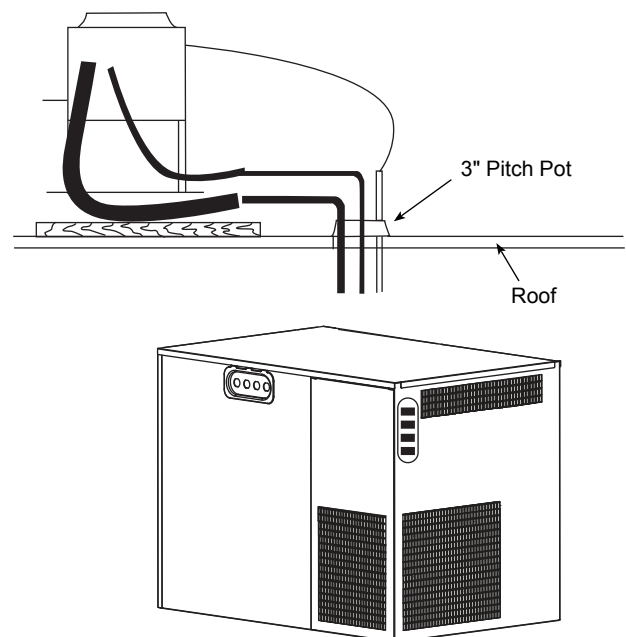

- Locate the pre-charged refrigeration lines shipped with the system. These lines must be a correct length for the building design. Avoiding any kinks, neatly route these lines from the remote condenser to the refrigeration unit. Excess refrigeration tubing must be handled in one of two ways. When coiling the excess tubing, make sure the inlet to the coil is at the top of the coil and the exit is the bottom of the coil. There can be no more than one turn to the coil. If you have more tubing, you must cut out the excess before connecting the ends. When cutting the tubing, you must first evacuate the refrigerant (line sets have a positive refrigerant holding charge of two to three ounces). After shortening and welding the tubing together again, you must evacuate the tubing to 250 microns. Then recharge the tubing with 4 ounces of appropriate refrigerant.

 **Caution**

Excess refrigeration tubing must be properly cared for before being connected to either the remote condenser or the refrigeration unit.

CONNECTING THE PRE-CHARGED REFRIGERATION LINES

NOTE: Before connecting the pre-charged refrigeration lines, the refrigeration unit must be properly located, leveled, and the water bath filled 1" (2.5 cm) below the installed drain pipe.

1. Attach low side gauge set to service port on each line set to verify positive pressure within the line set.

NOTE: If for any reason the lines are damaged and/or leaking or the lines no longer charged, refer to "How To Re-charge the Line Sets". If the line set is too long for the application, refer to "How to Shorten the Line Sets" in Section 3.

2. Always make the connections at the condenser first, using the end of the pre-charged lines with the valve ports.
3. Connect the condenser side with the quick connectors (discharge and liquid) up to condenser. Refer to the section titled "Aeroquip Connection" in these instructions.
4. Connect the refrigeration unit side with the quick connects (discharge and liquid). Make sure to provide a discharge trap at back of refrigeration unit, or bend discharge line down 12" and then up smoothly (no kinks) to provide a trap.
5. If a low refrigerant charge is detected, recover and recharge the system adding the unit name plate charge.
6. Repair any damages to the line sets before proceeding.

Preparing Glycol

MIXING GLYCOL SOLUTION

1. Inspect the glycol reservoir tank for dirt and/or foreign debris. The tank must be clean before mixing glycol solution.
2. Locate the glycol kit:
 - Model 75 3 Gallons (11 ltr) Glycol
 - Model 150 5 Gallons (19 ltr) Glycol
 - Model 300 15 Gallons (57 ltr) Glycol
 - Model 450 20 Gallons (75 ltr) Glycol
3. Pour the glycol into the reservoir tank.

⚠ Caution

Do not turn on the circulating pump(s) until system installation is complete.

4. Add water until level of glycol/water solution reaches the "Fill Here" mark located on tank wall.

NOTE: The glycol/water solution in the water bath is now mixed to the proper ratio.

5. Push the switches marked "Compressor" and "Agitator" if equipped to the ON position. After compressor cycles OFF, check to ensure glycol solution reads 27°F (-2.7°C) to 29°F (-1.6°C).

⚠ Caution

Glycol water ratio should be maintained at a 3 to 1 ratio (17-22 Refractometer). Additional water will be required after starting pumps and solution fills circulation system.

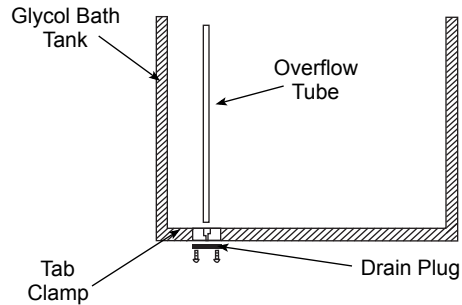

NOTE: Verify that the pump box holding tank is full before proceeding.

6. Turn on the circulator. The circulator must run continuously. Verify that glycol is returning to the glycol bath through the return bulk head fitting.

Additional Glycol Circulating Pump and Motor Kit

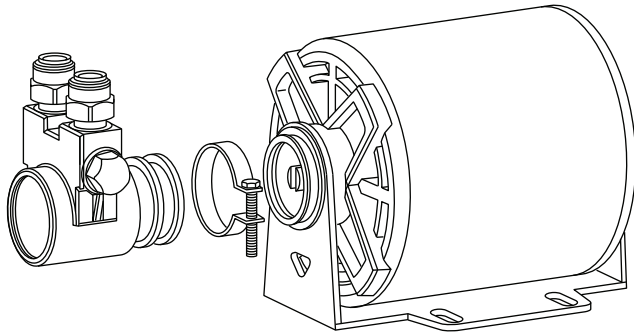

Pump and Motor Kit

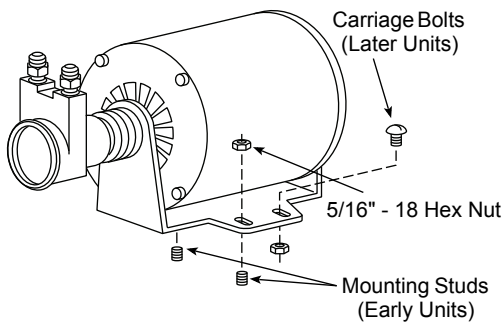

Motor Installation

NOTE: Only two fasteners required.

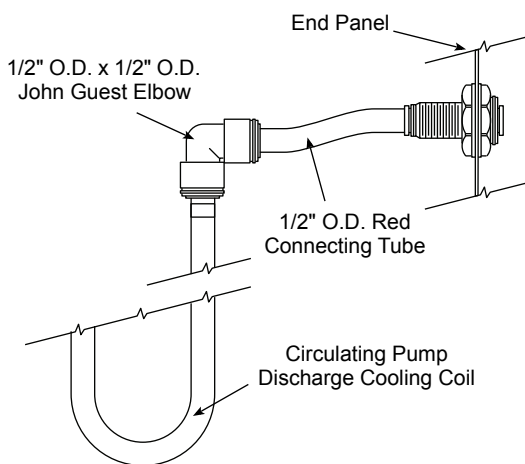

Tube Installation

INSTALLING THE GLYCOL CIRCULATING PUMP AND MOTOR KIT

1. Remove the lid from the Beermaster refrigeration unit.
2. Install the glycol circulating motor with pump to the motor shelf located in the Beermaster Glycol Unit motor compartment (see "Motor Installation" figure).

NOTE: Motor must be installed with the glycol pump facing away from the glycol bath.

3. Locate the pickup tube and discharge tube assemblies. Slide one piece of insulation over each of the tube assemblies (see "Tube Installation" figure).
 4. Attach the pickup tube to the inlet side of the glycol pump making sure the opposite end from the pump is submerged in glycol bath.
 5. Attach the discharge tube to the outlet side of the glycol pump.
 6. Slide the 1/2" x 1/2" John Guest Elbow, supplied in kit, onto the end of the discharge tube at pump motor assembly.
 7. Locate the circulator pump discharge cooling tube, supplied with kit, and insert into the water bath area. Insert straight end of tube into the John Guest elbow fitting as shown.
 8. Insert the two 1/2" O.D. John Guest bulkhead unions, supplied in kit, into the pre-punched holes located in the end of the refrigeration unit.
 9. Locate the two 1/2" O.D. tube retaining collets, provided in kit, and insert into each of the John Guest bulkhead unions.
 10. Insert the free end (bent end) of the circulator pump coil tube into the lower John Guest bulkhead union.
- NOTE: Do Not discard the condensation cover over the reservoir tank. It is necessary to prevent excessive condensation from diluting the water-glycol mixture.
11. Locate the 1/2" O.D. x 4" or 8" plastic tube, provided with kit. Insert one end of this tube into the upper bulkhead fitting. Insert opposite end of this tube into hole of strainer plate (see "Pump Connections" figure).

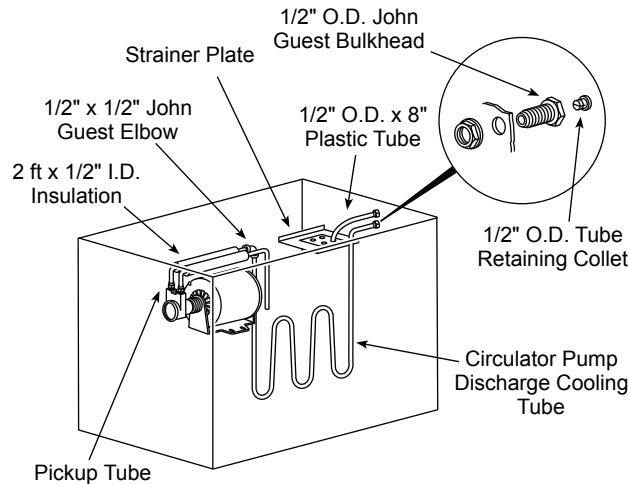

Pump Connections

12. Locate the 8 ft piece of cork tape, provided with kit, and insulate the glycol pump and all exposed connections to prevent condensation.
13. Remove and discard safety plug from connector of wire harness coming from control box. Attach connector of glycol pump motor to connector of wire harness coming from control box.
14. Installation of glycol circuit pump is now complete. The Beermaster refrigeration unit can now be turned ON.
15. The added glycol circulating pump can now be controlled by a switch located on the switch box.
 - For Model 450, the CIRC #4 switch will control added pump.

NOTE: After starting the new circulator pump, it may be necessary to top off the glycol bath with the proper propylene glycol/water mixture to maintain marked level in tank.

Beermaster Dispensing Towers

INTRODUCTION

The following instructions will cover installation procedures required for properly installing Beermaster Dispensing Towers. Kit includes one (1) Template, (1) Beermaster Dispensing Tower, (4) Mounting Screws (for Wooden Counter Top), (1) Gasket, (2) 3/8" MF x 1/2" John Guest Adapters, (1) 3/16" Barb x 1/2" John Guest Adapter, and (1) Adjustable Clamp.

1. Determine desired location of beer tower.
2. Using the template provided, locate and mark the center of the tower column.
3. Cut a 3" (7.6 cm) hole and place the tower over the hole to locate and mark the mounting screw positions.
4. Drill appropriate holes for mounting (1/8" diameter when using screws provided, if mounting in wood).

NOTE: If more than one tower is being installed, use only the tower intended for each location to mark the mounting screw positions.

5. Position gasket over top of 3" (7.6 cm) access hole and align holes for mounting screws. It is recommended that a small bead of silicon caulking be placed on both sides of the gasket at this point.
6. Route beer tower beverage lines through 3" (7.6 cm) hole and secure dispensing tower base to counter with mounting hardware.
7. Ensure lines are neatly sealed and wrapped until the necessary beer and glycol connections can be made, as outlined in the Conduit Kit Installation Kit section.

⚠ Caution

The 6 ft beer restrictor lines for beer tower should not be trimmed until completely reviewing the instructions for conduit kits.

DISPENSING TOWER TEMPLATE FOR BEERMASTER DISPENSING TOWER

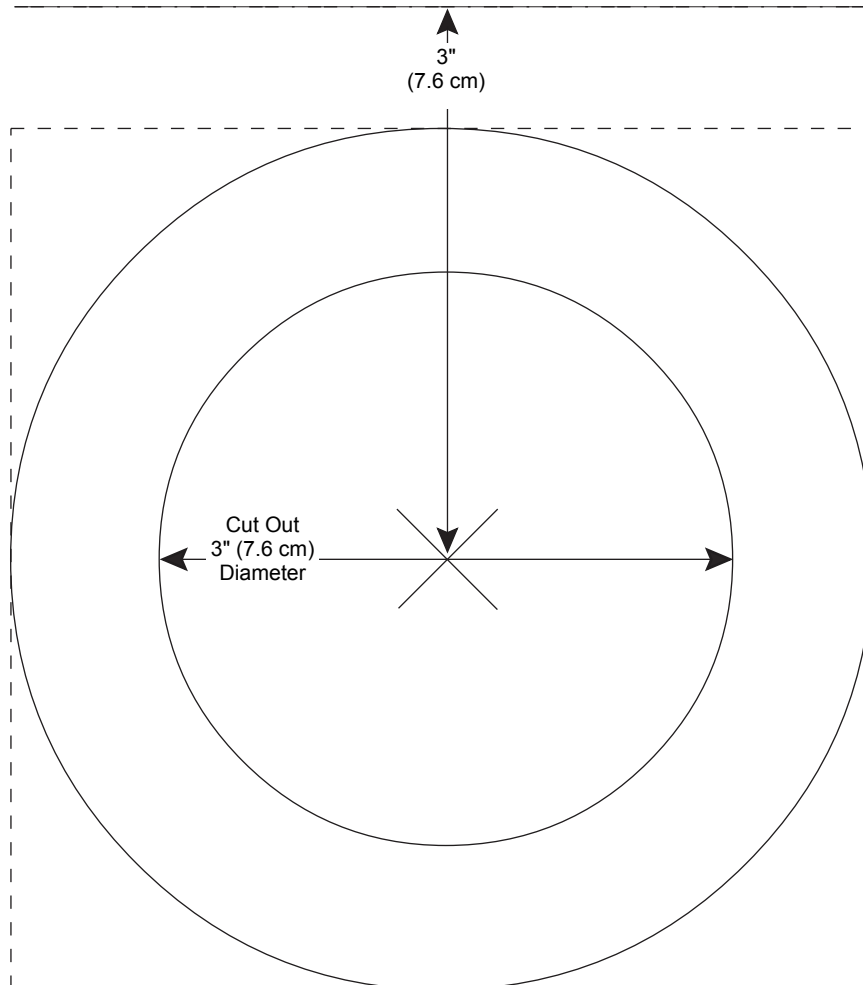

Beermaster High Pressure CO₂ Regulator (00211500)

INTRODUCTION

The following instructions will cover procedures required for properly installing the Beermaster high pressure CO₂ regulator.

KIT CONTENTS

- (1) Beermaster High Pressure CO₂ Gas Regulator with seal
- 20 ft of 5/16" I.D. tubing
- (6) # 8 screws
- (6) tie mounts
- (6) self locking cable ties
- (4) tab clamps

Installation should only be performed by qualified personnel.

INSTALLING

1. Determine the location where the beer system CO₂ tank(s) will be located. CO₂ tanks must be chained securely in place.
2. Attach the primary regulator to the CO₂ tank. Use seal provided in kit (see the "Attaching Regulator" figure).
3. Neatly route the 5/16" I.D. vinyl tubing from the primary regulator(s) to the secondary regulator in the beer keg cooler or to the optional blender.
4. Secure the vinyl tubing in place with tie mounts and cable ties provided in kit (see the "Securing Vinyl Tubing" figure).

NOTE: At start-up the primary regulator should be adjusted to 40 PSI (2.8 bar) and locked.

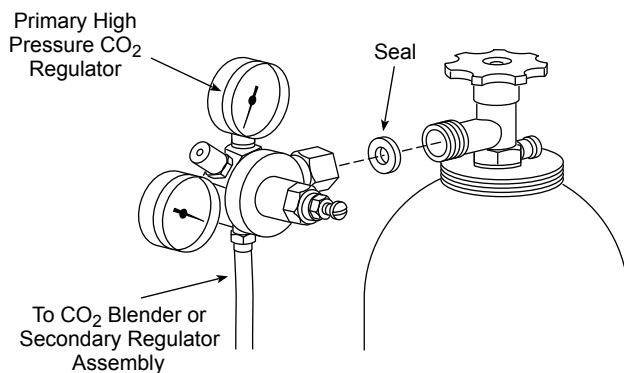

Attaching Regulator

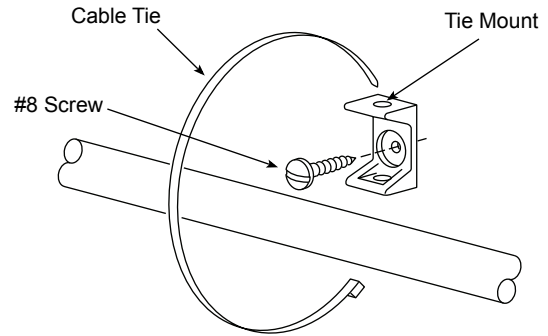

Securing Vinyl Tubing

Beermaster Dual Secondary Regulator Kit (00211400)

INTRODUCTION

The following instructions cover the installation of a Multiplex secondary regulator panel kit. Each dual secondary regulator kit will handle two beer kegs. Additional dual secondary regulator kits can be placed in series to handle additional beer kegs.

KIT CONTENTS

- (1) dual secondary regulator assembly with wall bracket
- CO₂ gas lines
- Beer lines
- 12 ft - 5/16" I.D. black vinyl tubing
- (10) boss coupling washers
- (8) tab clamps
- (1) 1-1/4" MPT pipe plug
- 6 ft - 3/8" I.D. clear vinyl line assembly

INSTALLING

Refer to the "Secondary Regulator Installation" figure for the following procedures:

1. Mount the dual secondary regulator panel in a convenient location above the area where beer kegs will be stored.
2. Route the CO₂ gas line from the primary high pressure regulator (or gas blender) and attach to the 5/16" Barb fitting of the secondary regulator. Use two tab clamps.

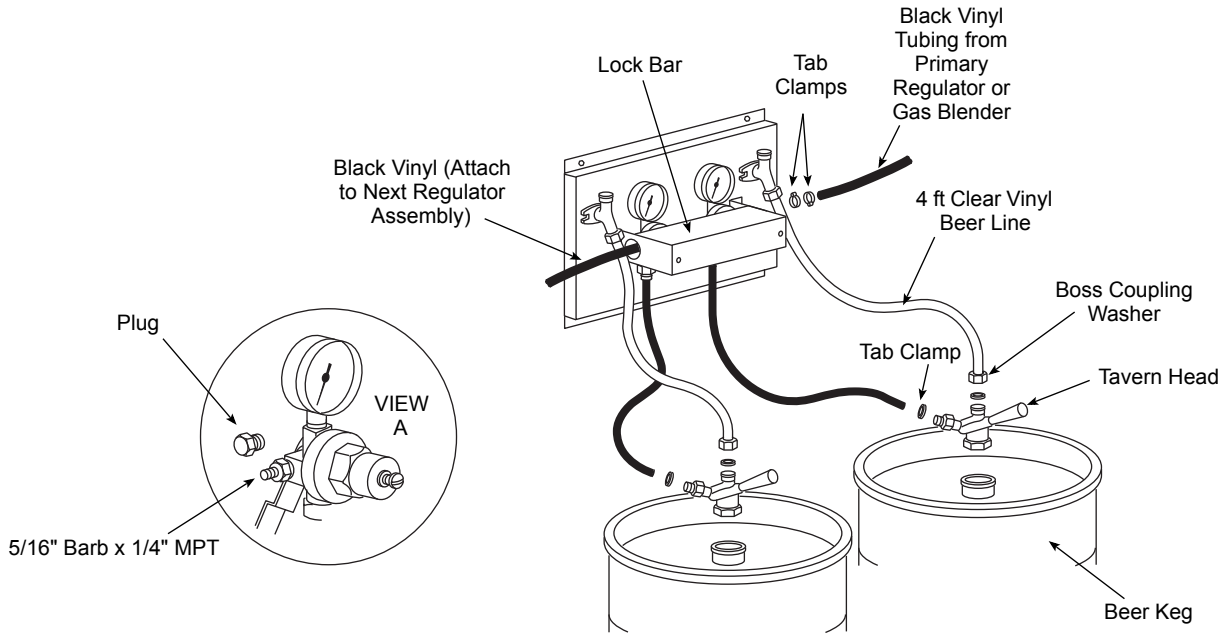

Secondary Regulator Installation

3. Cut the black vinyl CO₂ gas line looped between the two regulators. Attach each CO₂ gas line to the 5/16" inlet of the tavern head (not provided). Use one tab clamp per connection.
4. Attach each of the clear vinyl beer lines to the beer outlet of the tavern head. Use one boss coupling washer, 3/8" nipple and hex nut (provided in kit) at each connection.
5. Additional dual secondary regulator kits can be placed in series from the first regulator panel. To plug the last regulator in a series of regulators, remove the Barb fitting from the regulator outlet and install the 1/4" MPT plug, provided in kit (see the "Secondary Regulator Installation" figure, View A).

NOTE: Do not adjust pressure regulators at this point. See "Conduit Kit" section for regulator adjustments.

Beermaster Blenders

N₂/CO₂ BLENDER (SINGLE — 00520182, DUAL — 00520183)

Installing

1. Decide where the N₂/CO₂ Blender Kit will be mounted.

NOTE: Be sure the panel is on a wall in a well ventilated, accessible indoor area that is out of harm's way.

2. Mount the panel on the wall.
3. Hook-up panel using thread sealant on threads and a back-up wrench on panel fittings.

NOTE: Do not use fittings with check valve on inlets. Do not remove 1/4" female threaded fittings from panel, as they contain filters.

4. Test all fittings for leaks.

5. Use regulators and tubing suitable for 70 – 150 PSI.

NOTE: Regulators set at 50 PSI are suitable on a 50 PSI blender.

6. Secure all cylinders to the wall.

NOTE: Store cylinders in a well ventilated, accessible area.

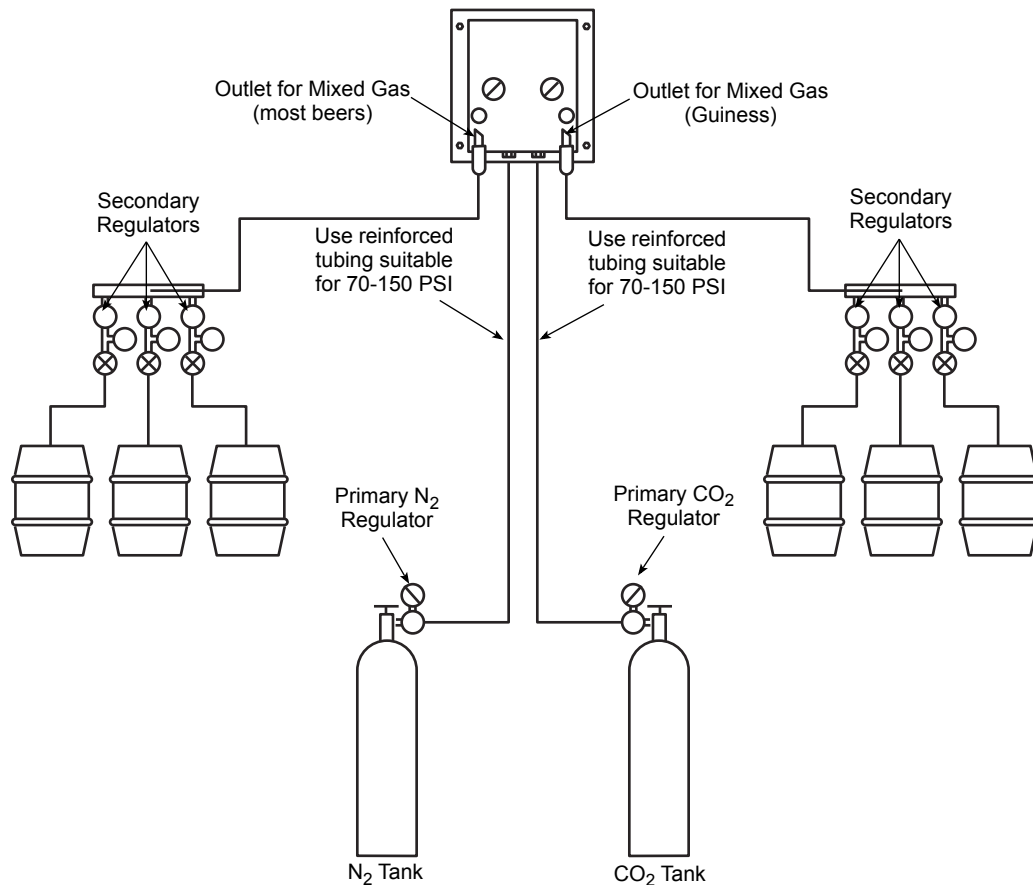

Installation Checklist

- Check all fittings and conduit attachments for leaks. Check all insulated connections to make sure that they are sealed.

- Observe the pump operations for leaks.

- Check the glycol bath for full ice bank.

- The stabilized water bath operating temperature must be maintained at 33°F (.6°C) to 35°F (1.7°C).

- Close glycol bath feeder valve completely.

Section 3 Operation

Typical System

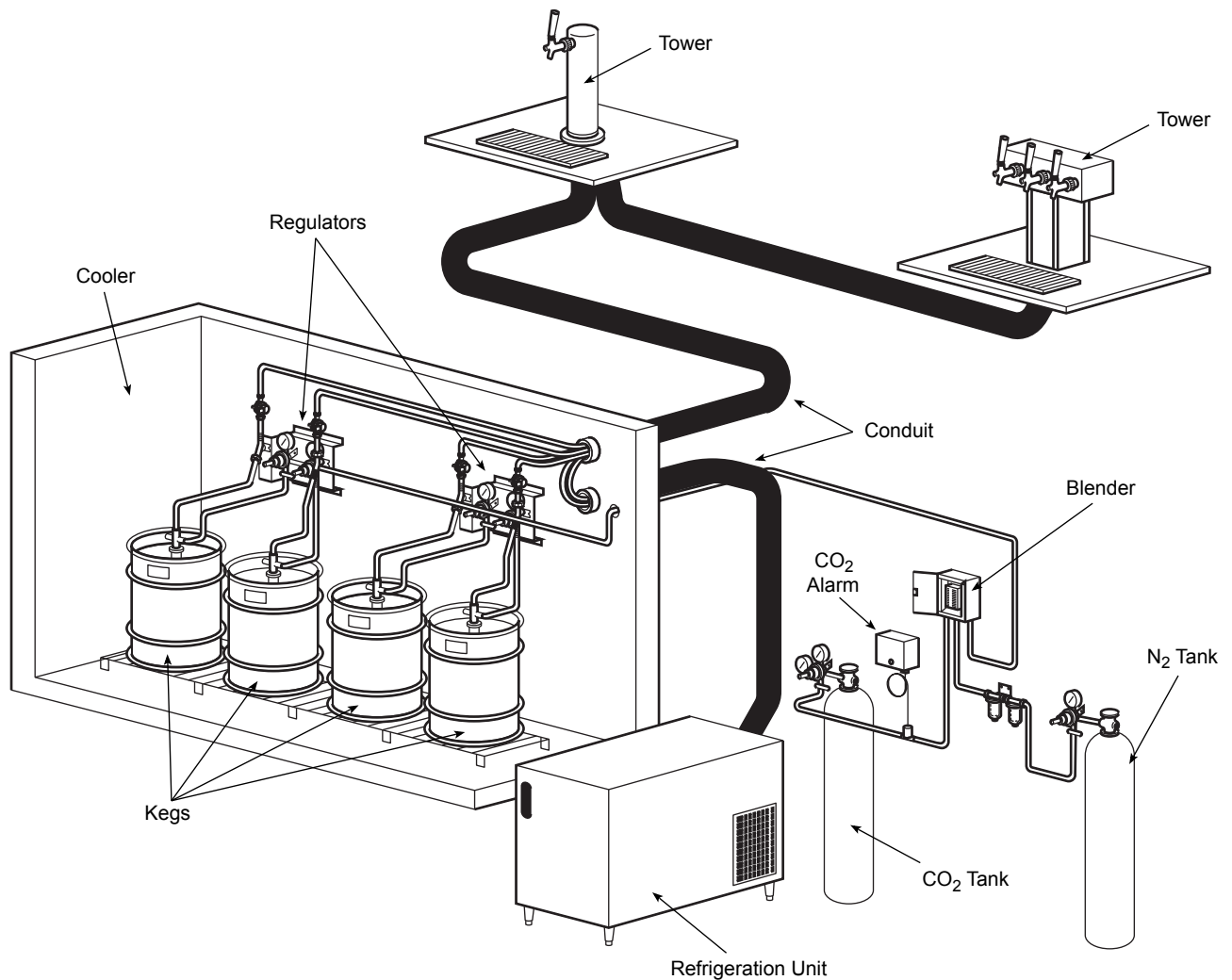

These refrigeration units are remote refrigeration units that derive their peak capacity from the water/glycol bath. These systems are controlled to cycle ON and OFF depending on the temperature of the glycol bath. The sensing bulb that controls the bath temperature is located on an adjustable bracket in the glycol bath.

How the Multiplex Works

The refrigeration units are remote refrigeration units that derive their peak capacity from the water/glycol bath. A tower is used to dispense the beer at the desired location. Conduit (an insulated bundle of tubing) connects the refrigeration unit and kegs of beer to the tower. The conduit has the beer and glycol lines wrapped together and the glycol is circulated to keep the beer in the conduit lines cold. The refrigeration system is controlled by a sensing bulb located on an adjustable bracket in the glycol bath. Depending on the setpoint of the temperature control, the refrigeration system cycles ON and OFF as the temperature of the glycol bath changes.

Start-up

PLACING EQUIPMENT IN OPERATION

Before placing equipment in operation, verify that all requirements for roof mounted Remote Condenser Units (if applicable) have been satisfied. Refer to the instructions on installing the Remote Condenser.

1. Fill the refrigeration unit bath tank with (3:1) water/glycol mix to within 1/2" (1.27 cm) of the top of the overflow tube.
2. Turn on the rocker switch labeled "Refrigeration" to begin cooling the glycol and energize the agitator motor in the glycol bath.
3. The water/glycol bath will reach it's operating temperature within 2 to 4 hours.
4. If optional CO₂/N₂ Control Panel has been installed, refer to the installation instructions for operation and testing the circuits for leaks.
5. All circuits must be checked for leaks and possible cross circuits before turning ON.
6. Turn on the rocker switches for the circulating pumps.
7. Add glycol/water mix as needed to maintain correct bath level.

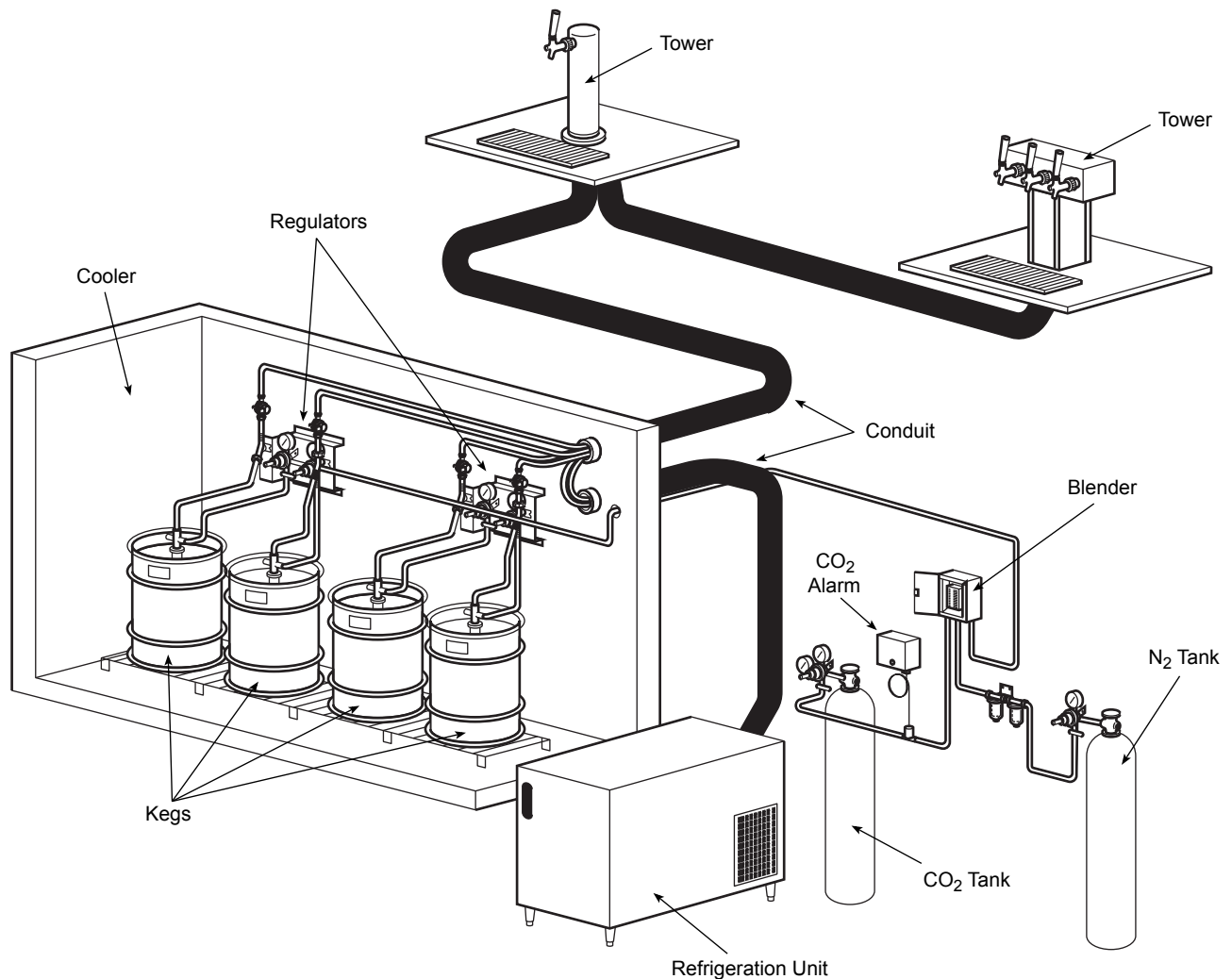

Multiplex Beermaster System Operation and Layout

Equipment Setup and Close Procedure

EQUIPMENT SETUP PROCEDURE

1. Ensure that all valve nozzles are attached to the valves.
2. Observe pressure of CO₂ high pressure tank of 500 PSI (34 bar) or more, or bulk CO₂ tank of 150 PSI or more. Primary regulator set at 90 PSI (6 bar) and the secondary regulator set at 35-40 PSI (2.4-2.6 bar) depending on the type of beer.
3. Observe the control panel to verify that all pressure gauges are set at correct operating pressures.
4. Check the kegs to make sure a sufficient number of kegs are connected in series to satisfy business volume.

5. Clean beer inlet and outlet quick disconnects at the same time tanks are replaced. Rinse disconnects in clean potable water.

EQUIPMENT CLOSE PROCEDURE

1. Clean the underside of the dispensing tower around the nozzle area with a clean damp towel.
2. Pour at least 60 oz (1.8 liters) of warm water down the drain openings.

System Calculators

BEER PUMP, SYSTEM PRESSURE AND CHOKER CALCULATOR

Section A:				
Product you are dispensing		Cooler Temperature		°
Natural Keg Pressure for this product at this temperature (see chart below)				A=
Add 1 # If your altitude is above 2,000 feet (per 2000 feet or portion thereof)				B=
Total push gas pressure to keg Add A + B				C=
Section B:				
Line run length	Feet	X 0.07 # per foot		D=
PLUS Rise from bottom of keg to outlet of faucet	Feet	X 0.5 # per foot		E=
MINUS Fall from bottom of keg to outlet of faucet	Feet	X 0.5 # per foot		F=
PLUS choker	Trunk Line Length	3/16" Choker Tube Length	# Resistance (G)	G=
	Up to 100 feet	13 feet	39 lbs.	
	100 to 125 feet	12 feet	36 lbs.	
	125 to 150 feet	11 feet	33 lbs.	
	150 to 175 feet	10.5 feet	31.5 lbs.	
	175 to 200 feet	10 feet	30 lbs.	
Over 200 feet contact factory				
Plus resistance if using Kyees tower		ADD	+4.8	H=
If using Kyees Chill Pak		ADD	+4.0	I =
If using bent tube assembly in tower		ADD	+3.0	J =
Total initial resistance Add D +E – F + G +H + I + J				K=
Set the Beer Pump pressure regulator at (K)				

A = Natural Keg Pressure at Sea Level (PSI)					
Product	Cooler Temperature				
	32°	34°	26°	38°	40°
Anheuser-Busch	9	10	11	12	13
Coors	13	14	15	16	17
Miller	10.5	11.5	12.5	13.5	14.5
Schlitz / Stroh's	10	11	12	13	14

BLENDED GAS BEER SYSTEM PRESSURE AND CHOKER CALCULATOR

Line run length	Feet	X 0.07 # per foot	
PLUS Rise from bottom of keg to outlet of faucet	Feet	X 0.5 # per foot	+
MINUS Fall from bottom of keg to outlet of faucet	Feet	X 0.5 # per foot	-
PLUS minimum 24" choker			+ 6.0
If using Kyees tower		ADD + 4.8	
If using Kyees Chill Pak		ADD + 4.0	
If using bent tube assembly in tower		ADD + 3.0	
		Total initial resistance	=
If total initial resistance is 20 # or greater *, you have the Applied Keg Pressure and length of choker tube. If initial resistance is less than 20 #, add additional choker as below.			
	Minimum Pressure *		
	Minus Total initial resistance as calculated above		-
	Equals initial additional resistance to add		=
	Times 4		X 4
	Equals initial number of inches choker tube to add		=
	Round up the number of initial inches choker tube to add to the next 1" segment		
	Plus minimum choker length		+ 24"
	Total amount of choker hose to use in the run with 20 # Applied Keg Pressure		=

* If your altitude is above 2,000 feet, add 1 # per 2000 feet or portion thereof to the minimum pressure stated above.

PURE CO₂ BEER SYSTEM PRESSURE AND CHOKER CALCULATOR

Section A:			
Product you are dispensing		Cooler Temperature	°
Natural Keg Pressure for this product at this temperature (see chart below)			A=
Add 1 # If your altitude is above 2,000 feet (per 2000 feet or portion thereof)			B=
Total Gas Push Pressure	USE THIS AS YOUR KEG PRESSURE Add A + B		C=
Section B:			
Line run length	Feet	X 0.07 # per foot	D=
PLUS Rise from bottom of keg to outlet of faucet	Feet	X 0.5 # per foot	E=
MINUS Fall from bottom of keg to outlet of faucet	Feet	X 0.5 # per foot	F=
PLUS minimum 24" choker	Feet	X 3.0 # per foot	G=
Plus resistance if using Kyees tower		ADD +4.8	H=
If using Kyees Chill Pak		ADD +4.0	I =
If using bent tube assembly in tower		ADD +3.0	J =
		Total initial resistance Add D + E - F + G + H + I + J	K=
Ideal Resistance (C)			L =
Minus Total initial resistance as calculated above (K)			M =
Equals initial additional resistance to add			N =
Take value of (N) Times 4			O =
Round up (O) to the next foot (i.e. 15 inches, round up to two feet)			P =
Add the original 2 feet choker			Q = 2 Feet
Add P + Q			R = Feet
			This is the total amount of choker to use

Natural Keg Pressure at Sea Level (PSI)					
Cooler	Temperature				
	32°	34°	36°	38°	40°
Anheuser Busch	9	10	11	12	13
Adolph Coors	13	14	15	16	17
Miller	10.5	11.5	12.5	13.5	14.5
Schlitz / Stroh's	10	11	12	13	14

Section 4

Maintenance

Major Components

DISPENSING STATIONS

Daily (365 Times per Year)

- Take temperature of beer. Pour off the first glass and take the temperature of the second glass of beer. The proper temperature of the dispensed beer is 36°F (2.2°C) to 40°F (4.4°C).
- Flush all dispenser drains, pour hot water down drains at closing.

BEVERAGE CONDUITS

Every 4 Months (3 Times per Year)

- Inspect floor chases and seal any open chase ends.
- Inspect beverage conduits for damage. Re-insulate and seal any un-insulated areas.

AIR COMPRESSOR

Monthly (12 Times per Year)

- Drain condensate water from air compressor tank and filters.

Every 4 Months (3 Times per Year)

- Inspect air compressor filter and replace if clogged. Air filter must be replaced every six months.
- Inspect air compressor to verify proper cut-in at 70 PSI (4.8 bar) and cut-out at 90 PSI (6.2 bar). Adjust pressure switch if necessary.
- Inspect secondary air pressure regulator setting to blender, verify proper 40 PSI (2.8 bar) pressure setting. Adjust if necessary.
- Inspect system for air leaks, repair as required.

REFRIGERATION UNIT

Every 4 Months (3 Times per Year)

- Clean the refrigeration unit air cooled condenser using a vacuum cleaner.
- Inspect glycol bath, verify level of glycol solution is to fill mark. If below mark, add food grade glycol solution to bring level back up to mark.
- Clean out all glycol pump strainers.
- Check the temperature difference between the discharge and return glycol lines at the glycol bath. It should be within 3°. Verify proper pump efficiency and temperature control displays between 27°F (-2.7°C) and 29°F (-1.6°C).
- Inspect agitator motor and ensure proper operation.

GAS BLENDER

Every 4 Months (3 Times per Year)

- Inspect gas blender and verify CO₂ and air flow meters are set at the proper flow rate. Adjust if necessary.

CO₂ GAS SUPPLY

Every 4 Months [3 Times per Year]

- Inspect pressure setting at CO₂ high pressure regulator. Verify proper 40 PSI (2.8 bar) pressure setting. Adjust if necessary.
- Inspect all secondary beer regulators. Verify proper pressure settings. Adjust if necessary.
- Inspect system for CO₂ leaks. Repair as required.

Scheduled Frequency

Daily (365 times per year)

- Take temperature of beer. Pour off the first glass and take the temperature of the second glass of beer. The proper temperature of the dispensed beer is 36°F (2.2°C) to 40°F (4.4°C).
- Flush all dispenser drains, pour hot water down drains at closing.

Monthly (12 times per year)

- Drain condensate water from air compressor tank and filters.

Every 4 months (3 times per year)

- Inspect floor chases and seal any open chase ends.
- Inspect beverage conduits for damage. Re-insulate and seal any un-insulated areas.
- Inspect air compressor filter and replace if clogged. Air filter must be replaced every six (6) months.
- Inspect air compressor to verify proper cut-in at 70 PSI (4.8 bar) and cut-out at 90 PSI (6.2 bar). Adjust pressure switch if necessary.
- Inspect secondary air pressure regulator setting to blender, verify proper 40 PSI (2.8 bar) pressure setting. Adjust if necessary.
- Inspect system for air leaks, repair as required.
- Inspect gas blender and verify CO₂ and air flow meters are set at the proper flow rate. Adjust if necessary.

- Inspect pressure setting at CO₂ high pressure regulator. Verify proper 40 PSI (2.8 bar) pressure setting. Adjust if necessary.
- Inspect all secondary beer regulators. Verify proper pressure settings. Adjust if necessary.
- Inspect system for CO₂ leaks. Repair as required.

Shipping, Storage and Relocation

 **Caution**

Before shipping, storing, or relocating this unit, beer systems must be sanitized. After sanitizing, all liquids (sanitizing solution and water) must be purged from the unit. A freezing environment causes residual sanitizing solution or water remaining inside the unit to freeze, resulting in damage to internal components.

Section 5

Before Calling for Service

Checklist

If a problem arises during operation of your refrigeration unit, follow the checklist below before calling service. Routine adjustments and maintenance procedures are not covered by the warranty.

Warning

Only trained and certified electrical and plumbing technicians must service this unit. All wiring and plumbing must conform to national and local codes.

Warning

The unit should be unplugged when servicing, except when electrical tests are required. Use extreme care during electrical circuit tests. Live circuits may be exposed.

Problem	Possible Cause	To Correct
Section 1: Restriction		
Too little restriction		
Too much or too little restriction in a draught beer system will cause drawing problems. If draught beer system does not have enough restriction it may cause the following problems:		
A recovery problem simply means that the beer is leaving the beer line faster than the keg can fill the line. When this occurs it creates a vacuum in the keg which acts as if there was a low pressure on the beer in the keg. This causes the CO ₂ to come out of the beer line causing foaming problems. (The following symptoms occur most frequently during the high volume time of day.)	When drawing one beer, the beer flows very fast.	Since the recovery problem symptoms simulate a low pressure problem, check to make sure that the CO ₂ pressure in the keg is flowing and set properly.
	If a pitcher is drawn, the beer starts clear then starts to show intermittent streaks of foam followed by all foam.	Refer to your records to recheck your restriction calculation for the system. If you find your line does not have enough restriction, add the extra restriction to the 3/16" end of the beer line. If you have no records, make up a new beer line with the proper restriction and replace the existing line.
Beer draws too fast. If the beer draws clear but too fast and the pressure is properly set, there may not be enough restriction in the system.	Beer draws clear but foams in the glass.	Follow the second corrective step above.
	The beer draws too fast to satisfy the retailer and his help.	If the beer still flows too fast, continue to add more 3/16" restrictor line to the system to meet the retailer's needs.
Too much restriction		
If a draught beer system is over restricted it may cause the following problems:		
Beer draws too slow	Beer draws too slowly with little or no head.	First, ensure that the keg is properly tapped. Second, ensure that the CO ₂ is set at the proper pressure and is flowing to the keg. Check the beer faucet to ensure that there is no burr by the vent hole on the inside of the faucet.
	The beer appears to flutter or swirl out of the faucet causing the CO ₂ to break out of the beer and thus creating excess foam.	Systematically remove 6" of the 3/16" restrictor line until the beer flows with a full faucet and at a rate of flow desired by the retailer.

Problem	Possible Cause	To Correct
Section 2: Beermaster Glycol Chiller System		
When troubleshooting a closed remote system, one should consider the following areas:		
Temperature	Beer draws warm and is all foam.	Check coolant circulation by: <ul style="list-style-type: none"> • Inspecting the coolant circulation pump to ensure it is on and running. • Inspecting the coolant return line in reservoir to ensure it is circulating. Replace pump if necessary. Check coolant temperature by: <ul style="list-style-type: none"> • Adjusting the range from 27°F (-2.7°C) to 29°F (-1.6°C). • Fill reservoir to proper level with 3:1 glycol mix.
	No beer flows through system.	Check tap check ball and free if stuck. Check Coolant temperature. If it is less than 27°F (-2.7°C), the beer in the lines may be frozen. Turn OFF coolant compressor, then adjust coolant temperature to be between 27°F (-2.7°C) and 29°F (-1.6°C).
	First beer out always seems foamy or streaky.	Ensure that coolant line is in direct contact with the beer line right up to the back of the shank. If not, place aluminum foil between beer line and coolant line, then insulate. This will transfer the cold to the beer line.
	Beer in cooler is above 40°F (4.4°C).	Temperature of cooler ideally should be less than 38°F (3.3°C). Contact an authorized refrigeration service agency to set cooler.
	Glycol is dirty or too weak.	Clean reservoir and add new glycol solution (add new glycol to weak solution). Should give Brix on sugar refractor.
	Glycol solution is too warm.	Check outlet and inspect agitator for proper operation.
Pressure	Beer runs with streaks.	System may be under restricted. Add additional restriction to system by adding additional 3/16" I.D. vinyl tubing to the faucet end of the system.
	Beer draws great during slow time of day but turns to all foam during peak sale periods.	See above. Check regulator for proper operation. Check primary regulator to see if it allows enough CO ₂ for secondary regulators. Check walk-in cooler temperature is 38°F (3.3°C) or less.
Off-taste	Beer is flat.	Adjust air blender by increasing CO ₂ in blend and decreasing air in blend. Or there is no Air/ CO ₂ blender.
	Beer has off-taste (bitter or "skunky").	Change air intake filters. Check for moisture in air tank. Clean system. Check air intake supply. Check air filter and trap. Ensure proper rotation of kegs in series. Check cleaning schedule for beer lines.



Continuing product
improvements may necessitate
change of specifications without
notice.

Part Number 000003913 4/18



Multiplex
645 Park East Blvd, Suite 5
New Albany, IN 47150 USA
Ph: 844-724-2273 Fax: 812-246-7020
Visit us online at: www.welbilt.com