



MULTIPLEX[®]



CEV SERIES Beverage Dispensers

Installation, Use & Care Manual

This manual is updated as new information and models are released.
Visit our website for the latest manual. www.multiplexbeverage.com

Leader in Ice & Beverage Dispensers

Part Number 020004000 10/13

Safety Notices

As you work on Multiplex equipment, be sure to pay close attention to the safety notices in this manual. Disregarding the notices may lead to serious injury and/or damage to the equipment.

Throughout this manual, you will see the following types of safety notices:

Warning

Text in a Warning box alerts you to a potential personal injury situation. Be sure to read the Warning statement before proceeding, and work carefully.

Caution

Text in a Caution box alerts you to a situation in which you could damage the equipment. Be sure to read the Caution statement before proceeding, and work carefully.

Procedural Notices

As you work on Multiplex equipment, be sure to read the procedural notices in this manual. These notices supply helpful information which may assist you as you work.

Throughout this manual, you will see the following types of procedural notices:

Important

Text in an Important box provides you with information that may help you perform a procedure more efficiently. Disregarding this information will not cause damage or injury, but it may slow you down as you work.

NOTE: Text set off as a Note provides you with simple, but useful, extra information about the procedure you are performing.

Read These Before Proceeding:

Caution

Proper installation, care and maintenance are essential for maximum performance and trouble-free operation of your Manitowoc equipment. Read and understand this manual. It contains valuable care and maintenance information. If you encounter problems not covered by this manual, do not proceed, contact Multiplex Beverage. We will be happy to provide assistance.

Important

Routine adjustments and maintenance procedures outlined in this manual are not covered by the warranty.

Warning

PERSONAL INJURY POTENTIAL

Do not operate equipment that has been misused, abused, neglected, damaged, or altered/modified from that of original manufactured specifications.

NOTE: SAVE THESE INSTRUCTIONS.

We reserve the right to make product improvements at any time. Specifications and design are subject to change without notice.

Table of Contents (continued)

Section 1

General Information

Read This Manual	1-1
Unit Inspection	1-1
Model Numbers	1-1
Serial Number Location	1-2
Warranty Information	1-2

Section 2MBS

Installation Instructions

General System Overview	2-1
Pre-installation Checklist	2-2
Selecting Locations	2-4
Placing Unit in the Operating Position	2-4
Footprints	2-6
CEV30 Footprint	2-6
CEV40 Footprint	2-7
Location	2-8
Electrical	2-9
General	2-9
Minimum Circuit Ampacity	2-9
Electrical Requirements	2-9
Voltage	2-9
Minimum Circuit Amperage Chart	2-9
Refrigerant	2-9
Grounding Instructions	2-9
Unit Installation	2-11
Counter Sealing	2-11
Filling the water tank	2-11
Refrigeration System Start	2-12
Incoming Water Supply requirements	2-12
Connecting the Drain Pan Hose	2-12
Carbonator Tank Purge Tube Routing	2-13
Connecting Water & Syrup Supply Line(s)	2-14
Premix Pressures	2-14
Plumbing Diagrams	2-15
Carbonated/non-carbonated Conversion Instructions	2-17
CEV Bag-in-Box (BIB) Start-up	2-17
Install Labels	2-17
ADA Key Pads	2-18

Table of Contents (continued)

Section 3 Operation

Component Identification	3-1
Sequence of Operation	3-1
Unit Inspection	3-1
Beverage Valves	3-2
Carbonated Water	3-3
Syrup Delivery System	3-3
Back Room Package	3-3
Figal System	3-4
Figal Tanks	3-4
Racking	3-4
B-I-B	3-4
Pumps	3-4
Auto Bag Selectors	3-4
Operation Checks and Adjustments	3-5
Electronic Ice and & Carbonation Control	3-5

Section 4 Maintenance

Cleaning	4-1
Daily Cleaning	4-1
Water Bath	4-1
Cleaning Checklist	4-2
Preventive Maintenance	4-2
Sanitizing	4-2
Beverage System Cleaning	4-2
Shipping, Storage and Relocation	4-4

Section 5 Before Calling for Service

Checklist	5-1
Drink Troubleshooting	5-1
Pump Troubleshooting	5-2

Section 1

General Information

Read This Manual

Multiplex Beverage developed this manual as a reference guide for the owner/operator and installer of this equipment. Please read this manual before installation or operation of the machine. A qualified service technician must perform installation and start-up of this equipment, consult **Section 5** within this manual for service assistance.

If you cannot correct the service problem, call your MBS Service Agent or Distributor. Always have your model and serial number available when you call.

Your Service Agent _____

Service Agent Telephone Number _____

Your Local MBE Distributor _____

Distributor Telephone Number _____

Model Number _____

Serial Number _____

Installation Date _____

Unit Inspection

Thoroughly inspect the unit upon delivery. Immediately report any damage that occurred during transportation to the delivery carrier. Request a written inspection report from a claims inspector to document any necessary claim.

Model Numbers

This manual covers the following models:

Beverage Dispensers
CEVe-30, CEVe-40, CEVi-30, CEVi-40, CEVj-30



Warning

PERSONAL INJURY POTENTIAL

Do not operate equipment that has been misused, abused, neglected, damaged, or altered/modified from that of original manufactured specifications.

Serial Number Location

This number is required when requesting information from your local distributor. The serial number is listed on the SERIAL NUMBER DECAL affixed to the dispenser.

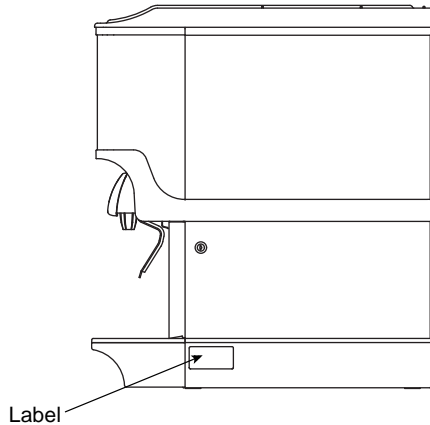

Serial Number Location

Warranty Information

Consult your local Multiplex Distributor for terms and conditions of your warranty. Your warranty specifically excludes all beverage valve brixing, general adjustments, cleaning, accessories and related servicing.

Your warranty card must be returned to MBS to activate the warranty on this equipment. If a warranty card is not returned, the warranty period can begin when the equipment leaves the MBS factory.

No equipment may be returned to Multiplex without a written Return Materials Authorization (RMA). Equipment returned without an RMA will be refused at Multiplex's dock and returned to the sender at the sender's expense.

Please contact your local Multiplex distributor for return procedures.

Section 2 Installation Instructions

General System Overview

These instructions are provided to assist the qualified installer. Contact your Multiplex Beverage Equipment Service Agent or call Multiplex Beverage Equipment for information regarding start-up services.

Important

Failure to follow these installation guidelines may affect warranty coverage.

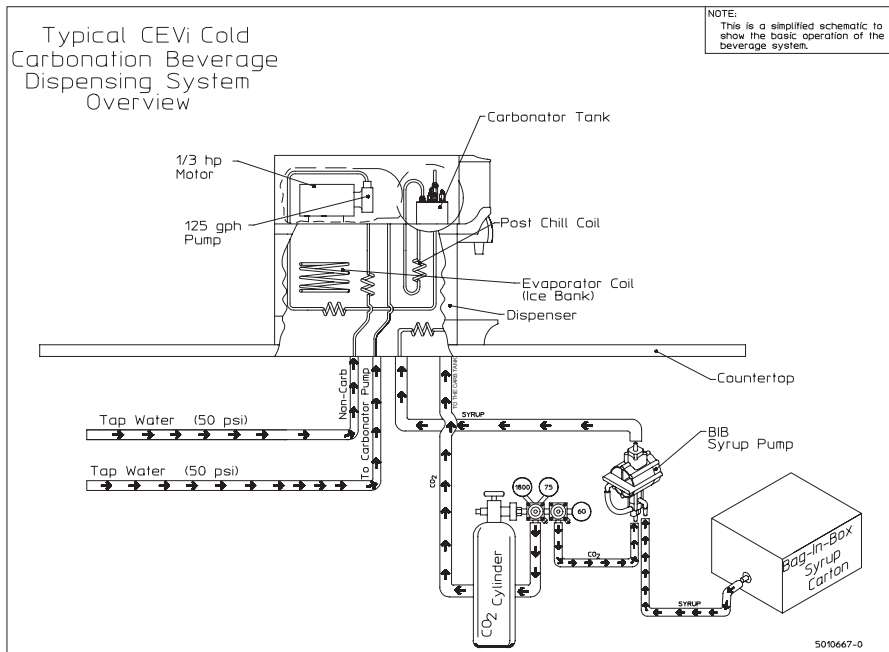

Typical CEV Series Internal Carbonation Beverage Dispensing System

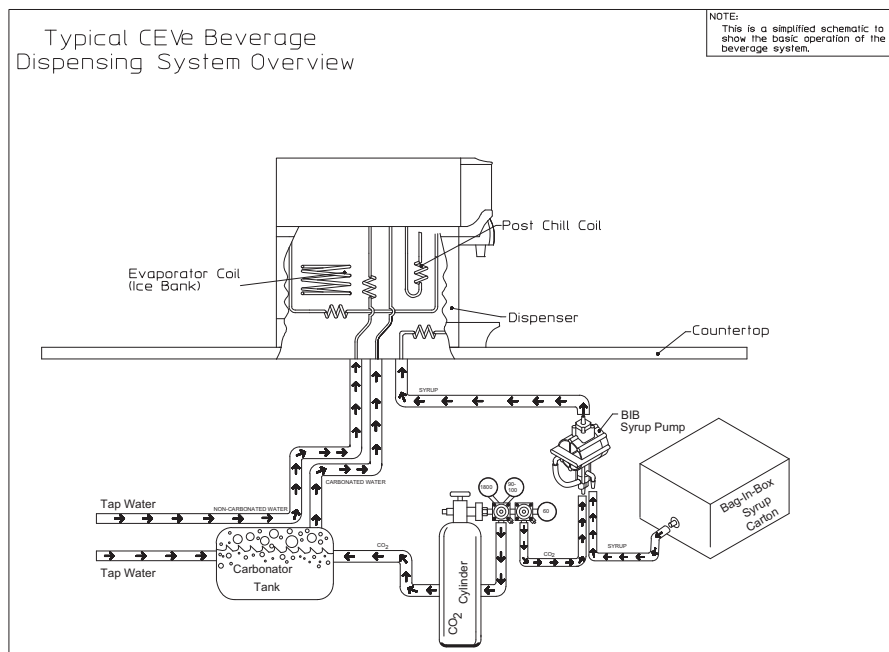

Typical CEV External Carbonation (Ambient) Beverage Dispensing System

Pre-installation Checklist

When installing any system, first make sure the major components are available. Generally the major components necessary for an installation are:

Pre-mix System:

- CO₂ regulator set
- Product connectors for Figal tank
- Gas connectors for Figal tank
- Beverage dispenser
- Beverage tubing
- CO₂ tank
- Figal beverage tanks
- Stepless (Oetiker) clamps
- Chain for CO₂ tank

B-I-B System also:

- B-I-B connectors
- B-I-B regulator set
- B-I-B rack
- B-I-B syrup boxes

Post Mix System:

- CO₂ regulator set
- Beverage dispenser
- Beverage tubing
- CO₂ tank
- Carbonator
- Stepless (Oetiker) clamps
- Chain for CO₂ tank

Figal system also:

- Syrup connectors for Figal tank
- Gas connectors for Figal tank
- Figal syrup tanks

Bulk Syrup System also:

Syrup connectors for Bulk tank

Gas connectors for Bulk tank

Bulk syrup tanks

Double Check:

Do you have enough space to install the dispenser or a dispenser and top mounted cuber?

Does top mounted cuber (if utilized) have a minimum of 6 inches (15.3 cm) clearance on all sides?

Is the countertop level?

Can the countertop support the weight of the dispenser, or the dispenser/cuber combination plus the weight of the stored ice?

Also consider the location of the following items before installation:

Water line

Drain

Power outlet

Heating and air conditioning ducts

Selecting Locations

The CEV may be island-mounted or installed on a front or rear counter. Locate the CEV so the following requirements are satisfied: CEV is for indoor use only and must NOT be placed in an area where a water jet or similar high pressure sprayer could be used.

1. CEV must be installed near a properly grounded electrical outlet with proper electrical requirements fused at proper amperage or circuit connected through an equivalent HACR circuit breaker with ELCB (GFCI). REFER TO UNIT NAMEPLATE FOR THE REQUIRED POWER CIRCUIT OPERATING VOLTAGE, HERTZ AND THE MINIMUM CIRCUIT AMPACITY OF THE CEV. No other electrical equipment should be connected to this circuit. ALL ELECTRICAL WIRING MUST CONFORM TO NATIONAL AND LOCAL ELECTRICAL CODES. MAIN PLUG MUST BE ACCESSIBLE FOR DISCONNECTION.
2. A minimum of 15-inches clearance must be maintained above the CEV to the nearest obstruction (shelf, cupboard, ceiling, etc.) and 4-inches clearance between the back of the CEV and the wall and 12-inches between each side and the wall. CEV has a top air outlet and is to remain free of all objects. Do not place anything on top of the CEV. The rear grill of the CEV must be unobstructed to allow air to enter the hood. This will also allow access to the condenser filter for cleaning.
3. If a permanent drain is to be used place CEV close to a permanent drain in order to route the drain pan hose to the permanent drain. Water tank overflow hose goes into the drain pan.

PLACING UNIT IN THE OPERATING POSITION

The CEV must be level horizontally from right to left and front to rear. CEV inlet supply lines, power cord, and drain pan hose must either be routed out of the CEV base rear access hole, or through a hole cut in the countertop under the CEV Unit. Proceed to applicable installation procedure. Two plastic tubing brackets are mounted under the CEV to hold the lines in place. The rear access cover may be removed, turned and installed to provide a brace to prevent the CEV from being pushed flat against the wall. Dimensions

Island Mount

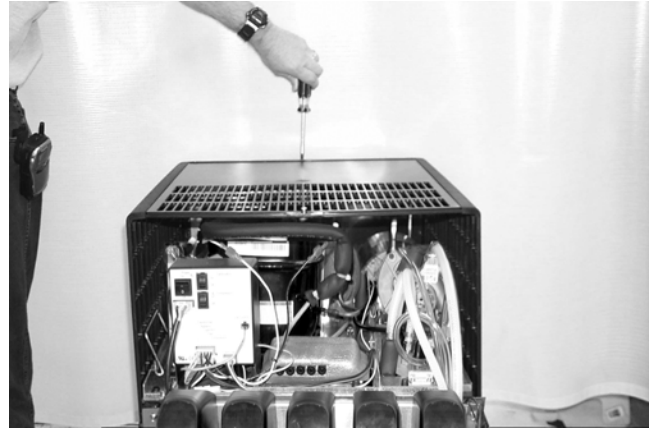

ABOVE: How to Remove the Bonnet

Place the CEV in location on the countertop flush with the countertop edge. Mark CEV's center line on the edge of the countertop, then move the CEV to one side. Starting at the center line mark on the edge of the countertop, measure back 12-inches for the location of a hole at least 4-inches to be cut into the countertop. Cut at least a 4 inch hole in the countertop where indicated. Place the CEV in position over the hole. Route the inlet supply lines, power cord, carbonator tank purge tube and drain pan hose down through the hole in the countertop. Install the line outlet plug, provided with the CEV in the base back access hole. The area around the inlet supply lines at the flanged hole behind the front access panel must be closed and sealed.

Counter Mount

Place the CEV in location on the countertop. Route CEV inlet supply lines, power cord, carbonator tank purge tube and drain pan hose out of the base back access hole. Area around inlet supply lines at flanged hole behind front access panel must be closed and sealed.

Counter Electric Dispenser Dimensions

* C = Valve height using Flomatic Valves.

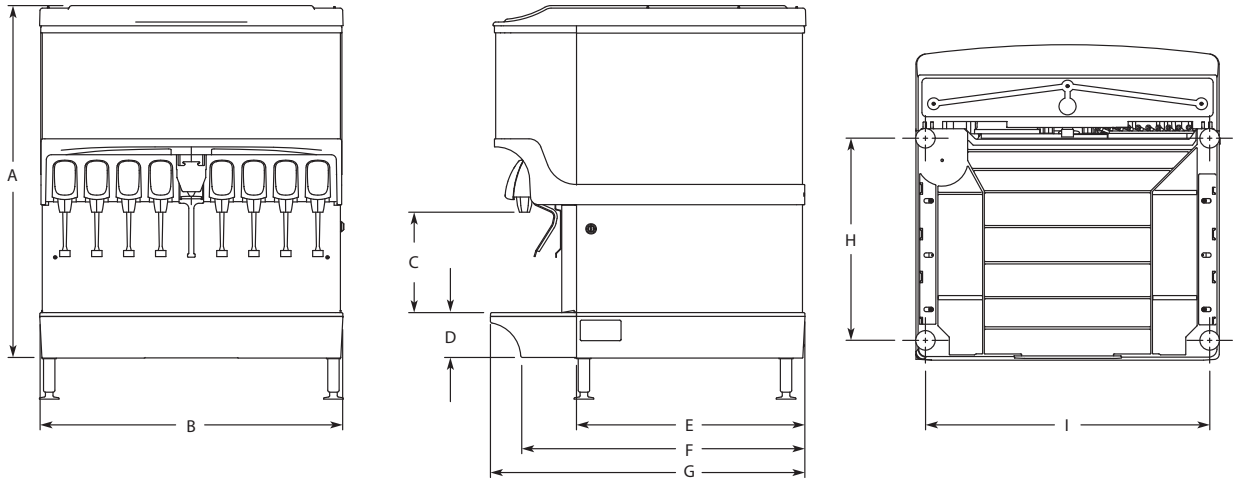

MODEL	A	B	C*	D	E	F	G	H	I
CEV-30	29.88" (75.9 cm)	20.50" (52.7 cm)	11.76" (29.8 cm)	4.44" (11.3 cm)	N/A	N/A	25.75" (65.4 cm)	17.00" (43.1 cm)	17.50" (44.4 cm)
CEV-40	29.88" (75.9 cm)	26.00" (66.0 cm)	11.76" (29.8 cm)	4.44" (11.3 cm)	N/A	N/A	25.75" (65.4 cm)	17.00" (43.1 cm)	23.00" (58.4 cm)

⚠ Caution

Cutting the countertop may decrease its strength. Counter should be braced to support the dispenser countertop weight plus ice storage capacity and weight of icemaker, if applicable.

Footprints

CEV30 FOOTPRINT

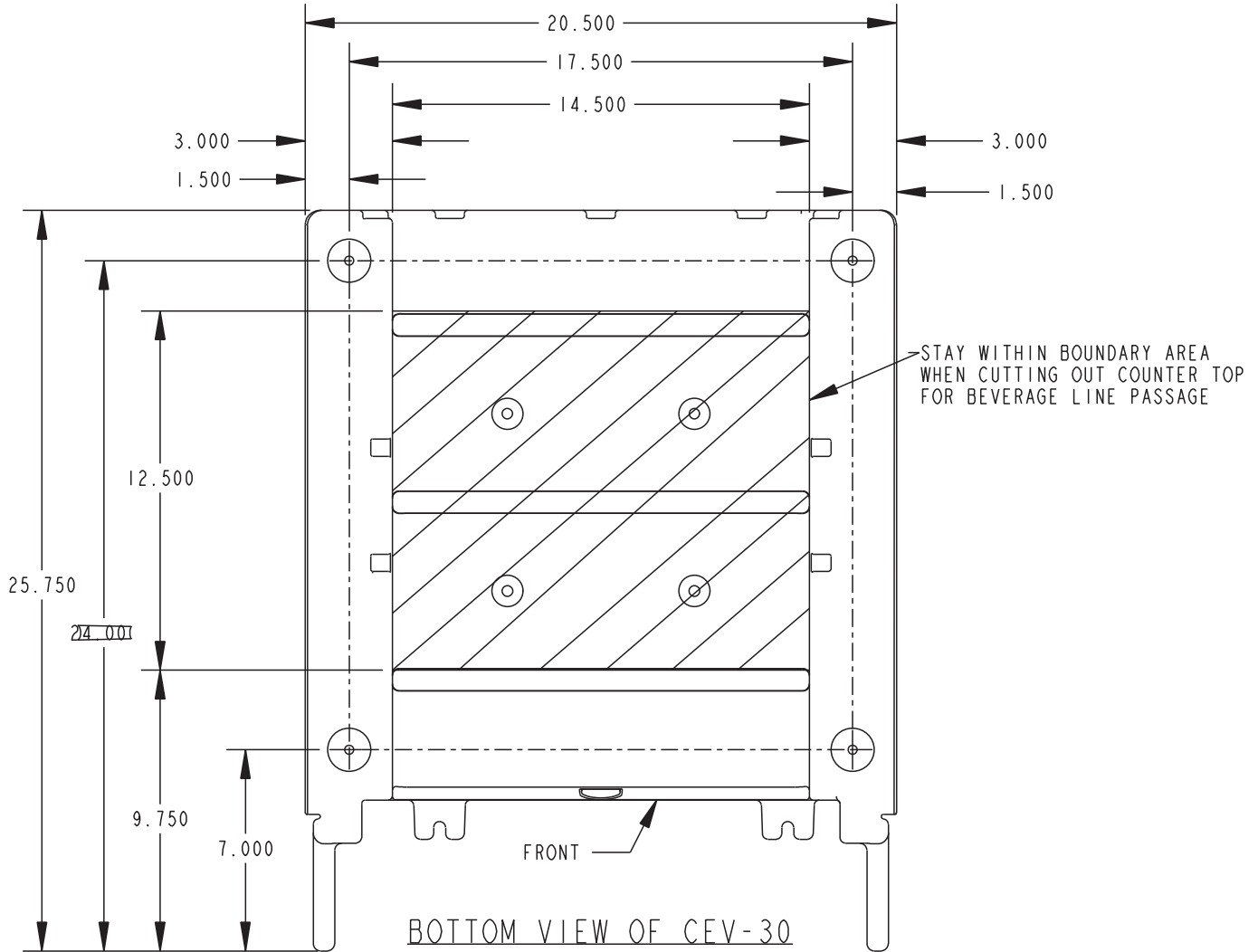

⚠ Caution
 Cutting the countertop may decrease its strength. Counter should be braced to support the dispenser countertop weight plus ice storage capacity and weight of icemaker, if applicable.

CEV40 FOOTPRINT

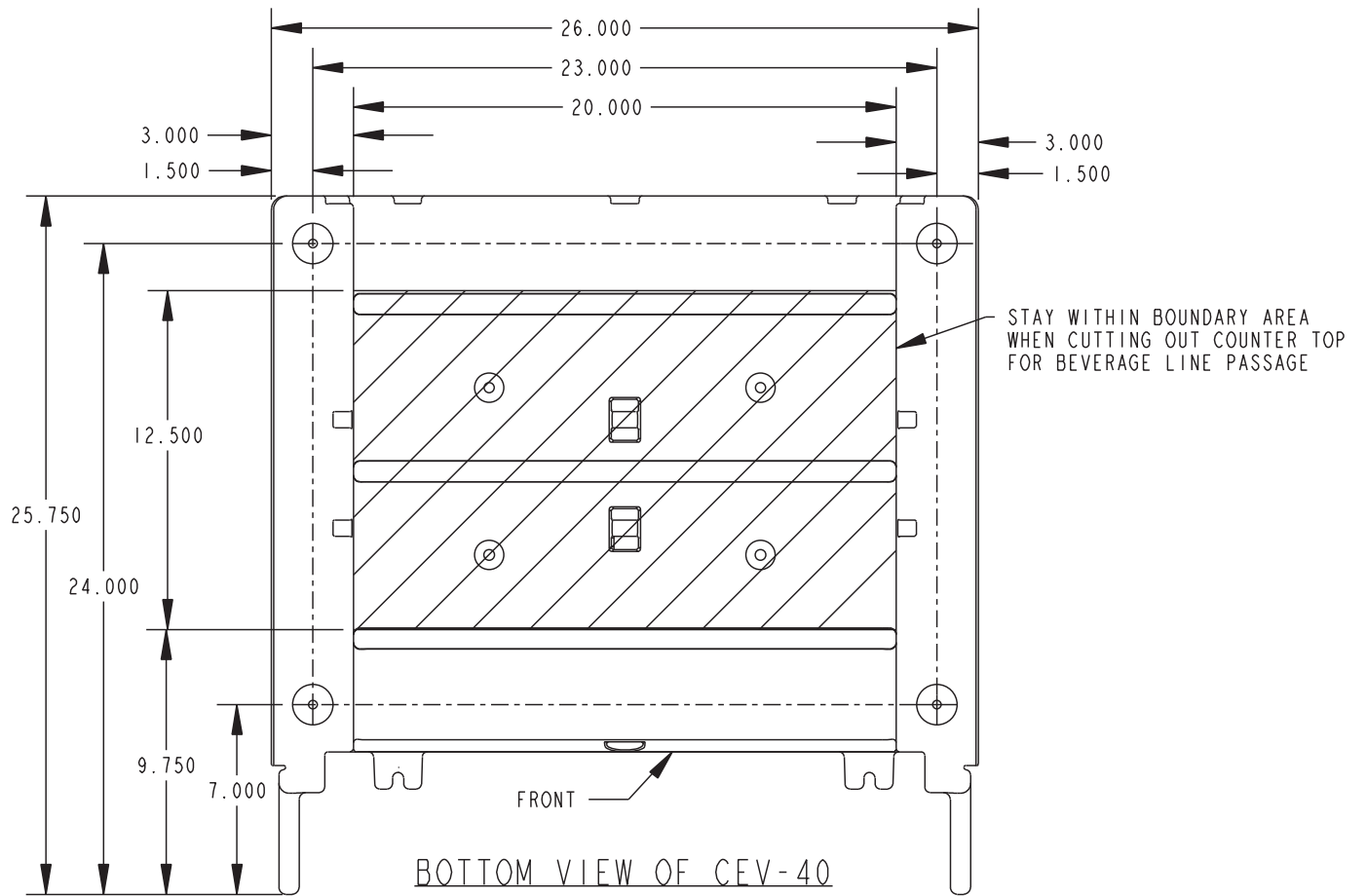

⚠ Caution
 Cutting the countertop may decrease its strength. Counter should be braced to support the dispenser countertop weight plus ice storage capacity and weight of icemaker, if applicable.

Location

Avoid placing the dispenser near heat sources such as radiators, ovens, refrigeration equipment and direct sunlight.

 **Warning**

Carbon Dioxide (CO₂) displaces oxygen. Exposure to a high concentration of CO₂ gas causes tremors, which are followed rapidly by loss of consciousness and suffocation. If a CO₂ gas leak is suspected, particularly in a small area, immediately ventilate the area before repairing the leak. CO₂ lines and pumps should not be installed in an enclosed space. An enclosed space can be a cooler or small room or closet. This may include convenience stores with glass door self serve coolers. If you suspect CO₂ may build up in an area, venting of the B-I-B pumps and / or CO₂ monitors should be utilized.

Electrical

GENERAL

 **Warning**
All wiring must conform to local, state and national codes.

MINIMUM CIRCUIT AMPACITY

The minimum circuit ampacity is used to help select the wire size of the electrical supply. (Minimum circuit ampacity is not the beverage/ice machine’s running amp load.) The wire size (or gauge) is also dependent upon location, materials used, length of run, etc., so it must be determined by a qualified electrician.

ELECTRICAL REQUIREMENTS

Refer to Machine Model/Serial Plate for voltage/ amperage specifications.

VOLTAGE

The standard voltage for CEV Series dispensers is 120VAC-60Hz 1 Ph. A power cord is provided with 120VAC-60Hz models only. 220/240 Volts - 50 Hz - 1 Ph, 208/230 Volts - 60 Hz - 1 Ph are also available.

MINIMUM CIRCUIT AMPERAGE CHART

Dispenser	Voltage/Cycle	Fuse Size	Circuit Amps
CEV-30, CEV-40	120/60	20 amp	8.2 Operating amps 13 FLA
	220/50, 240/50, 208/60, 230/60	10 amp	4.5 Operating amps 7.0 FLA

REFRIGERANT

Dispenser	Voltage/Cycle	Refrigerant	Compressor
CEV-30, CEV-40	120/60, 220/50, 240/50, 208/60, 230/60	R-134a - 8 oz	1/3 HP

Optimum Ambient Conditions are between 50°F and 95°F (10°C and 35°C).

Important

Due to continuous improvements, this information is for reference only. Please refer to the dispenser serial number tag to verify electrical data. Serial tag information overrides information listed on this page.

Grounding Instructions

 **Warning**
Risk of electrical shock. Connect to a properly grounded outlet only.

This appliance must be grounded. In the event of malfunction or breakdown, grounding provides a path of least resistance for electric current to reduce the risk of electric shock. This appliance is equipped with a cord having an equipment-grounding conductor and a grounding plug. The plug must be plugged into an appropriate outlet that is properly installed and grounded in accordance with all local codes and ordinances.

 **Warning**
Improper connection of the equipment-grounding conductor can result in a risk of electric shock. The conductor with insulation having an outer surface that is green with or without yellow stripes is the equipment grounding conductor. If repair or replacement of the cord or plug is necessary, do not connect the equipment-grounding conductor to a live terminal. Check with a qualified electrician or serviceman if the grounding instructions are not completely understood, or if in doubt as to whether the appliance is properly grounded. Do not modify the plug provided with the appliance — if it will not fit the outlet, have a proper outlet installed by a qualified electrician.

 **Warning**

When using electric appliances, basic precautions should always be followed, including the following:

- a. Read all the instructions before using the appliance.
- b. To reduce the risk of injury, close supervision is necessary when an appliance is used near children.
- c. Do not contact moving parts.
- d. Only use attachments recommended or sold by the manufacturer.
- e. Do not use outdoors.
- f. For a cord-connected appliance, the following shall be included:
 - Do not unplug by pulling on cord. To unplug, grasp the plug, not the cord.
 - Unplug from outlet when not in use and before servicing or cleaning.
 - Do not operate any appliance with a damaged cord or plug, or after the appliance malfunctions or is dropped or damaged in any manner. Contact the nearest authorized service facility for examination, repair, or electrical or mechanical adjustment.
- g. For a permanently connected appliance — Turn the power switch to the off position when the appliance is not in use and before servicing or cleaning.
- h. For an appliance with a replaceable lamp — Always unplug before replacing the lamp. Replace the bulb with the same type.
- i. For a grounded appliance — Connect to a properly grounded outlet only. See Grounding Instructions.

Unit Installation

COUNTER SEALING

In order for all CEV units to comply with NSF requirements within the United States, the CEV base must be sealed to the countertop unless the optional 4" legs are installed. All access holes to the base must be sealed. If the 4" legs are installed, proceed to Filling the Water Tank, otherwise proceed as follows to seal the CEV base:

- A. Tilt CEV up to expose bottom of base.



- B. Remove the 2 plastic tubes under the CEV.
 C. Liberally apply silastic sealant such as Dow Corning RTV 731 or equivalent on the base bottom edges.
 D. Lower the CEV into operating position on the counter top to complete the seal of the base to the countertop.



NOTE: Do not move CEV after positioning or the seal between the base and the countertop will be broken.

- E. Apply additional sealant around the bottom of the base. The seal must be a minimum of 1/4 inch to prevent crevices and to ensure a complete seal.

FILLING THE WATER TANK

Warning

CEV must be electrically grounded to avoid possible fatal electrical shock or serious injury to the operator. 120V CEV power cord is equipped with a three-prong plug. If supply cord is damaged it must be replaced by the manufacturer or its service agent or a similarly qualified person in order to avoid a hazard. If a grounded electrical outlet is not available, use an approved method to ground the CEV.

1. Make sure the plug in the water tank drain hose is secure.
2. Remove the plug from the water fill hole located on the carbonator pump deck. Fill the water tank with clean water until water flows out of the tank overflow. Use a funnel if necessary. Caution: Be careful not to spill water on any electrical fitting or connection. Do not use distilled water.

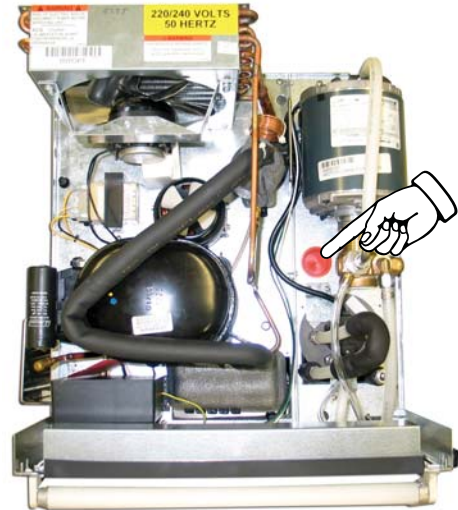

NOTE: An alternative method to fill the water tank would be to temporarily splice the incoming water line into the water tank drain hose, turn on the water and fill the tank until water comes out the overflow drain. Turn off the water and plug the water tank drain hose.

3. Install plug in water fill hole.
4. Place CEV power switch, compressor switch and the carbonator switch, located on the front of the control box, in "OFF" position.

NOTE: Complete control box instructions may be found in the Electronic Ice & Carbonation Control section.

REFRIGERATION SYSTEM START

- A. Assure the water tank is properly filled. The CEV will not operate without water in the tank.
- B. Assure the voltage switch on the left side of the control box is in the proper voltage position. Selections are 115 Volts or 230 Volts.
- C. Plug CEV power cord into an accessible, properly grounded electrical outlet. A dedicated circuit is strongly preferred to assure sufficient starting and operating voltage is available to the unit. Complete control box instructions may be found in the Electronic Ice & Carbonation Control section.
- D. Place CEV power switch, carbonator switch (not used on juice units) and compressor switch to the "ON" position. The agitator motor will start, the transformer for the valves will be energized, the merchandiser bulb (if equipped), power LED, carbonator LED, and compressor LED will be illuminated.

When a full ice bank has been formed, the compressor and condenser fan motor will stop, but the agitator motor will continue to operate, circulating ice bath water in the water tank. Turn the key switch to the "ON" position to check all beverage valves for operation.

Recommended: Beverage pour temperature should be maintained at a constant 40° F or below for optimum brixing value. Time required to reach the proper temperature will be subject to water and ambient air temperatures.

NOTE: All CEV units are equipped with a 4-5 minute delay before the compressor and fan motor start. Be sure to observe this time delay before expecting the compressor or condenser fan motor to start operation. Any interruption of power to the unit, the time delay will need to be observed before the compressor and fan motor will start.

INCOMING WATER SUPPLY REQUIREMENTS

NOTE: Multiplex Beverage Equipment recommends that a water shutoff valve and water filter be installed in the incoming water supply line.

The incoming water source to the equipment shall be installed with adequate backflow protection to comply with applicable National, State, and local codes.

Water pressure should be a minimum of 45 psi (310.3 KPa) or you will starve the pump of water and damage it. The maximum water pressure should be 55 psi (379.2 KPa) or you will affect the quality of the carbonation.

The carbonator pump should be located within 6 feet of a 1/2 inch water source. A minimum 3/8 inch ID water line must be used. Before connection the water source should be flushed of approximately 5 gallons of water to purge the system of any sediments, especially in areas of new construction.

CONNECTING THE DRAIN PAN HOSE

NOTE: Connection of the drain pan hose to a permanent drain is recommended. A drain pan hose routed to a waste container is not recommended due to sanitation problems.

1. Open the end of the drain pan nipple by cutting at the end of the barbed area along the provided groove.
2. Connect hose to the nipple on the drain pan.
3. Install drain pan in position on the CEV, then place grid in the drain pan.
4. Route lower end of drain pan hose to a permanent drain and connect according to local codes.



NOTE: If no permanent drain is available the drain pan may be emptied manually. All CEV's come equipped with a drain pan that may be removed by sliding it forward. Nothing else needs to be removed to take the drain pan off, empty it and replace it on the CEV. If this drain pan is hooked to a permanent drain, the drain nipple must be opened and connected to the drain hose as described above.

CARBONATOR TANK PURGE TUBE ROUTING

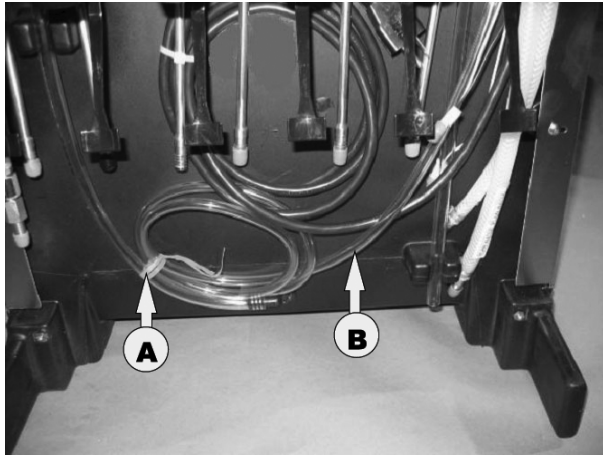

1. During installation of unit the carbonator tank purge tube (A) must be properly routed to a drain. Once the splash panel has been removed from unit remove twist tie (B) that holds carbonator tank purge tube.

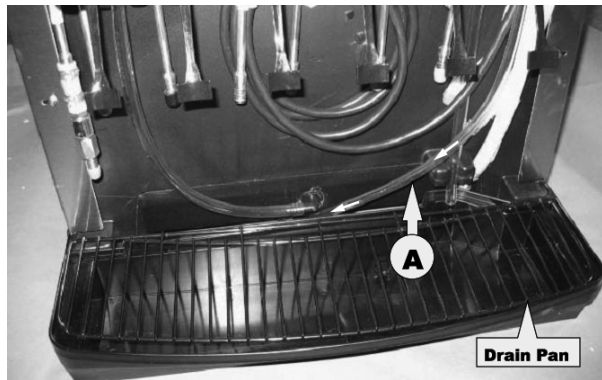

2. Purge tube is connected to the pressure relief valve on carbonator tank and must be routed to a drain. Route carbonator tank purge tube (A) down front of unit and behind drain pan. Be sure not to collapse or kink carbonator tank purge tube during routing from unit to drain.

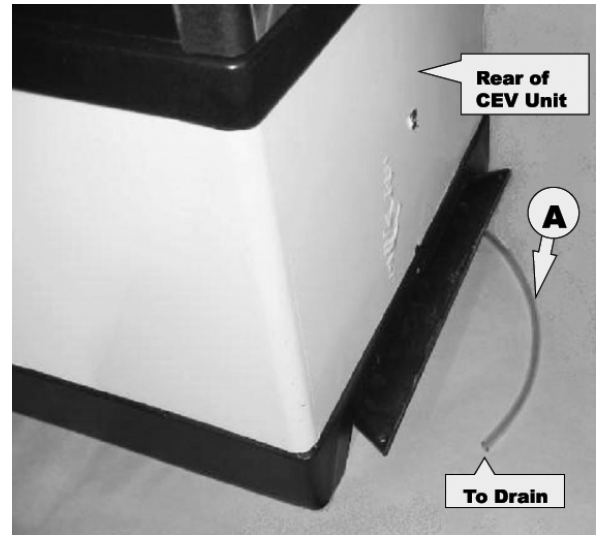

3. The carbonator tank purge tube (A) can be routed down through the counter top that unit has been installed on or out the rear of unit. Then install carbonator tank purge tube to a drain. Follow all local and national plumbing codes when routing carbonator tank purge tube to the drain.

NOTE: If there is no permanent drain, route the carbonator purge tube into the drainpan.

CONNECTING WATER & SYRUP SUPPLY LINE(S)**Water Lines**CEVi (Internal Carbonator)

Connect plain water supply line to the CEV at the plain water inlet line, and the non-carbonated water inlet.

CEVe (External Carbonator)

Connect carbonated water supply line from the external carbonator to the CEV at the carbonated water inlet line. Connect plain water supply line to the CEV at the non-carbonated water inlet line.

CEVj (Non-Carbonated Unit)

Connect plain water supply lines to the CEV at the plain water inlet line.

Syrup Lines

Connect syrup supply lines to the CEV at the corresponding syrup inlet lines. Syrup inlet line #1 will correspond with the left hand dispensing valve. The valves are numbered in sequence from left to right.

Connecting CO₂ Supply Line & Starting The CEVi

1. Connect CO₂ supply to the CO₂ inlet at the CEV.
2. Open carbonator tank pressure relief valve. (Yellow arm should be in the upright position).
3. Turn water supply on and fill the carbonator tank until water can be seen coming out the pressure relief valve.
4. Close the pressure relief valve.
5. Activate a dispensing valve until a good flow of plain water is established.
6. Check for water leaks.
7. Turn on the CO₂ bottle and adjust the regulator to 75 psi (517.10 KPa).
8. Activate a valve until all the water has been forced out of the system by the CO₂.
9. Check for any leaks.
10. Connect the power to the carbonator.
11. Operate the valves until the carbonator cycles several times and there is a good flow of carbonated water from each valve.

Connecting CO₂ Supply Line & Starting the CEVe

1. Connect CO₂ supply to the CO₂ inlet on the carbonator tank.
2. Connect carbonated water outlet line to the dispensing system. To avoid contamination of potable liquids, do not connect copper tubing or fittings between the discharge fitting on the carbonator and the dispensing valve.

3. Open carbonator tank pressure relief valve. (Yellow arm should be in the upright position).
4. Turn water supply on and fill the carbonator tank until water can be seen coming out the pressure relief valve.
5. Close the pressure relief valve.
6. Activate a dispensing valve until a good flow of plain water is established.
7. Check for water leaks.
8. Turn on the CO₂ bottle and adjust the regulator to 100 psi (689.48 KPa).
9. Activate a valve until all the water has been forced out of the system by the CO₂.
10. Check for any leaks.
11. Plug in the carbonator.
12. Operate the valves until the carbonator cycles several times.

CEVj Non-Carbonated

1. Open plain water inlet supply line valve. Check for water leaks, tighten any loose connections.
2. Operate each dispensing valve until the system is flushed and water flows smoothly from each valve.

PREMIX PRESSURES

Normal premix pressure regulators should be set at 60 psi (413.7 KPa). Diet premix pressure regulators should be set at 40 psi (275.8 KPa). If you are experiencing high foaming, slightly decreasing the pressures may correct the problem. Spitting and popping usually requires slightly increasing pressures. Premix beverage valve pressures vary by type and manufacturer. Please consult the manufacturer of the valves you are using for specific instructions regarding operation of the valve.

CEVi and CEVe System Pressures

1. Incoming tap water should be at a minimum pressure of 40 psi (275.8 KPa) with carbonator pump operating and a maximum of 55 psi (379.2 KPa) with pump stopped (measured at inlet to pump).
2. BIB pressure gauge set for 60 psi (413.69 KPa) or according to your line run.
3. Carbonator Pressure gauge (Use Preset Regulator):
 - Cold Carbonation set for 75 psi (517.1 KPa).
 - Ambient systems should be set at 90 psi (310.3 KPa) to 105 psi (310.3 KPa).

NOTE: If incoming water pressure is under 40 psi (275.8 KPa), a water booster is recommended. If incoming water pressure is over 55 psi (379.2 KPa), a water regulating valve is required.

PLUMBING DIAGRAMS

NOTE: A check valve must be installed in the water supply line 3 feet from the noncarbonated water connection "PW". Contact factory if not installed.

CEV-30e & CEV-30i 5 Valve Diagram

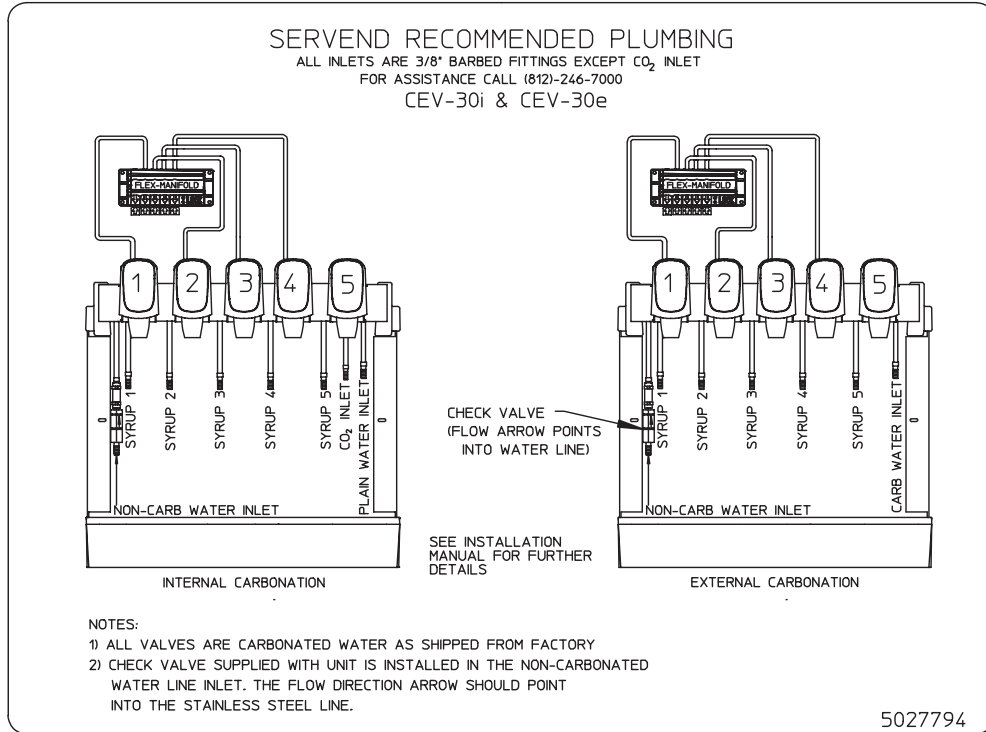

CEV-30e & CEV-30i 6Valve Diagram

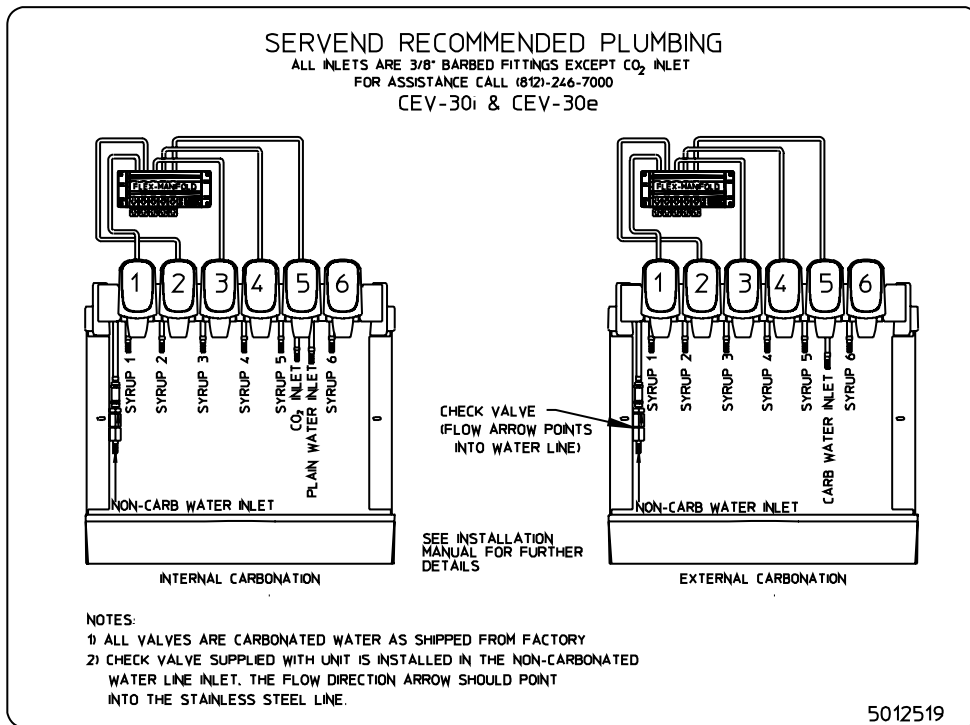

CEV-40e & CEV-40i 8Valve Diagram

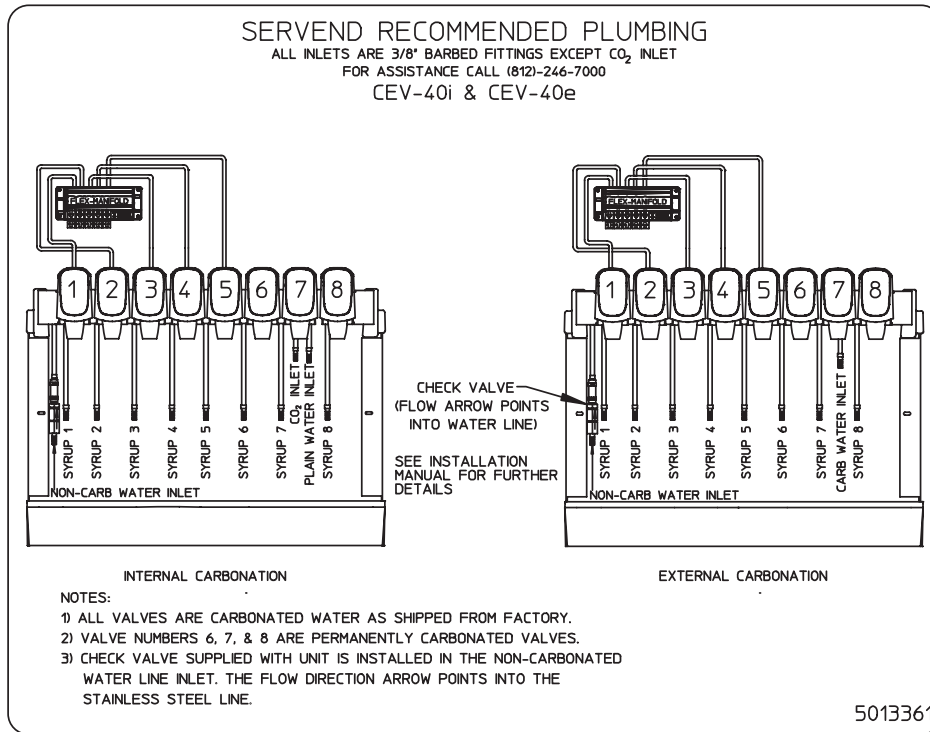

CEV-30j 4,5 & 6 Valve Diagram

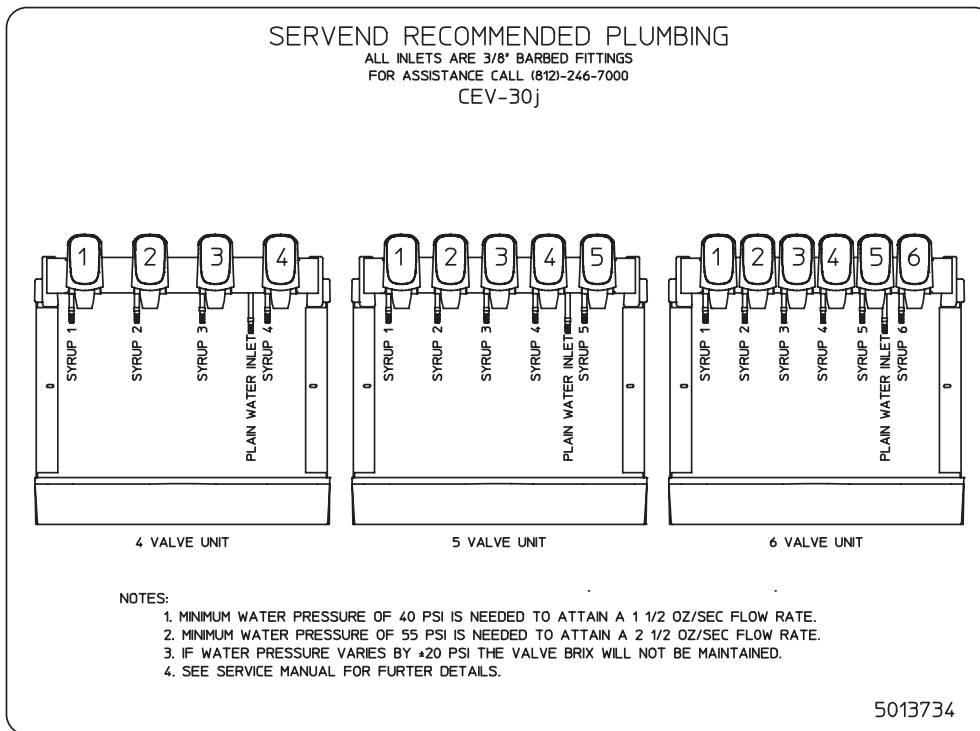

CARBONATED/NON-CARBONATED CONVERSION INSTRUCTIONS

OPERATION:

MANIFOLD TO CHANGE TO CARBONATED OR NON-CARBONATED WATER

- 1) TURN PLUNGER 180° USING A 5/32" HEX KEY WRENCH.
- 2) PULL PLUNGER OUT TO GET NON-CARB WATER. PUSH PLUNGER IN TO GET CARB WATER
- 3) TURN PLUNGER 180° TO LOCK.
- 4) PLUNGER IS LOCKED IN PLACE WHEN ARROWS ON MANIFOLD AND PLUNGER ARE ALIGNED.

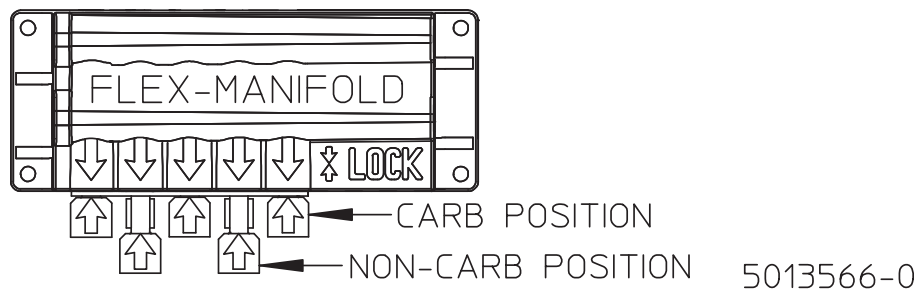

CEV BAG-IN-BOX (BIB) START-UP

All lines should be properly flushed and sanitized before starting the CEV. See Sanitizing Instructions

1. Connect each BIB connector to the appropriate BIB.
2. Gradually adjust the secondary regulator to 70 psi (482.6 KPa). Never run a BIB pump without the BIB installed as the pump could be damaged. Set final secondary regulator pressure 70 -75 psi (482.6 - 517.1 KPa) depending on the line size and the distance of the run.
3. Operate each dispensing valve until the syrup flows smoothly from the valve.

Adjust Syrup to Water Ratio (Brix) of Dispensed Product

1. Adjust water flow rate on each dispensing valve to 2.5 ounces per second.
2. Adjust dispensing valves for water-to-syrup ratio (brix) as recommended by the syrup distributor.

INSTALL LABELS

Install flavor labels (some labels are provided with the CEV) on the dispensing valve covers.

ADA KEY PADS

These instructions are for installations with this option.

1. Remove power from the unit.

Splash Panel Removal

2. Remove the splash panel from the unit by removing the drain pan to gain access to the two (2) phillips head screws holding it in place.

ADA Wiring

3. Route the ADA ribbon cable under the drain pan.

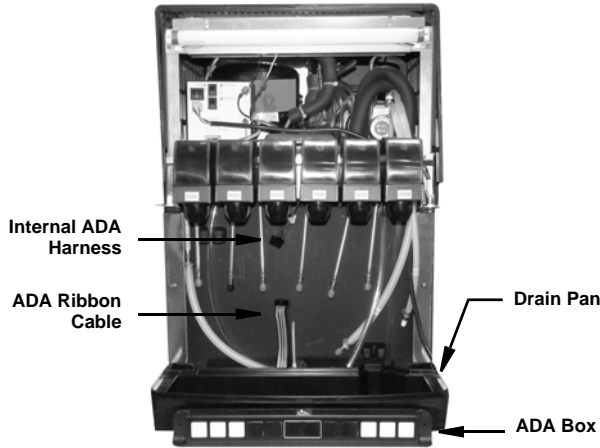

4. Continue routing the ADA cable up to the ADA harness clipped to the wall of the CEV and connect.

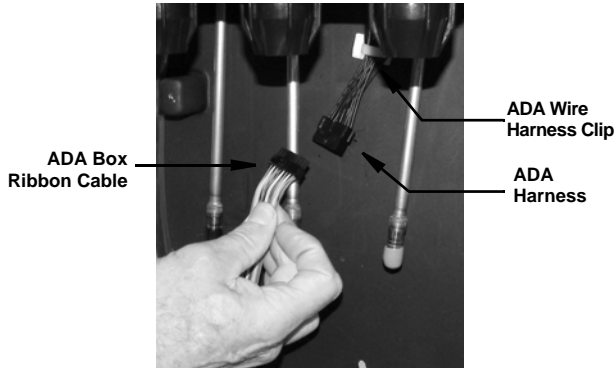

5. Neatly tuck in and take up any slack remaining in the ADA ribbon cable so it will not be in the way of any moving parts or panels when they are placed back on the unit.

Drain Pan & ADA Touch Pad Box

6. Attach the drain pan to the unit.
7. Center the ADA Key Pad Box with the unit in front of the drain pan and secure into place.

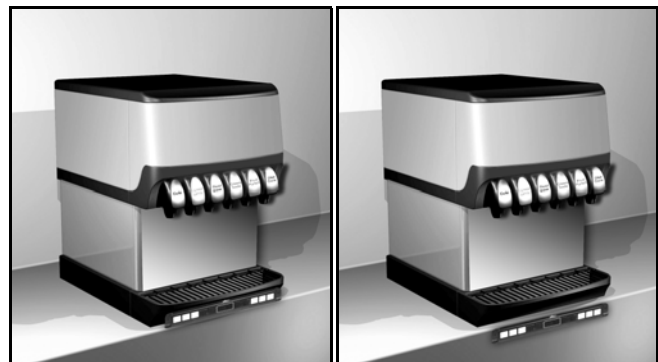
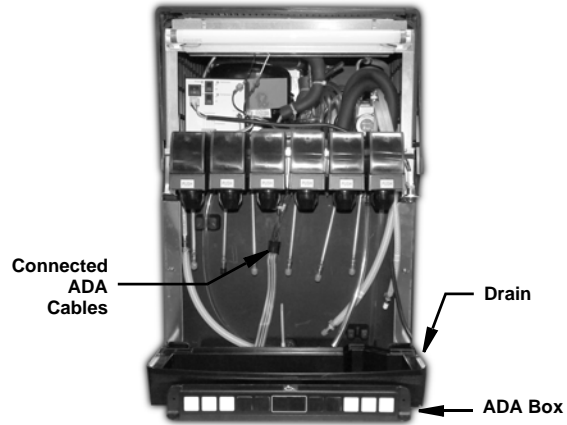

Important

If mounting the ADA Box directly in front of the drain pan on the counter top leave a minimum of 1 inch space between the bottom edge of the drain pan and the ADA Box to allow space for drain pan removal. CEV units may need more space for drain pan removal, mounting to the front edge of the counter top may be necessary.

8. Apply corresponding drink labels to the ADA key pads.
- NOTE:** Drinks correspond from left to right on the left side of the unit, and right to left on the right side of the unit. If buttons are not used they will be blanked out. The Cubed/Crushed buttons in the center are only utilized on units configured with the Selectable Ice feature.
(See ADA Key Pad Matrix Section 2-19)

ADA Key Pad Matrix

4 Valve Dispensers

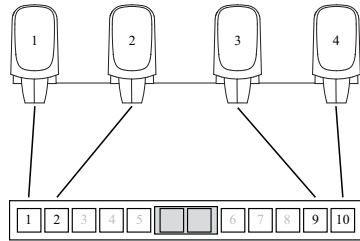

6 Valve Dispensers

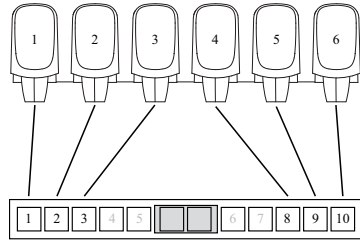

8 Valve Dispensers

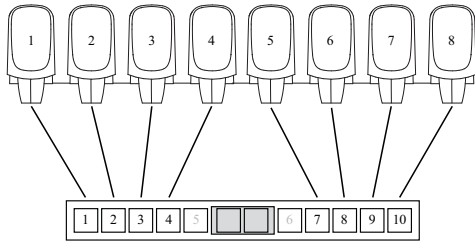

8 Valve Dispensers

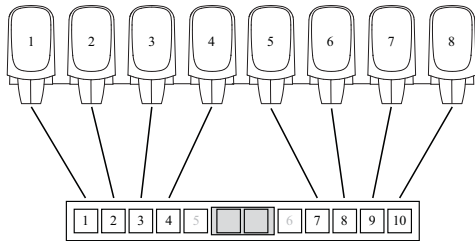

Finish Installation

- 9. Put the splash panel and merchandiser back onto the unit and reinstall the screws that hold them in place.
- 10. Restore power to the unit.

Clean Up

Clean up all work areas. Dispose of all packing material, excess tubing and trash properly.

Section 3 Operation

Component Identification

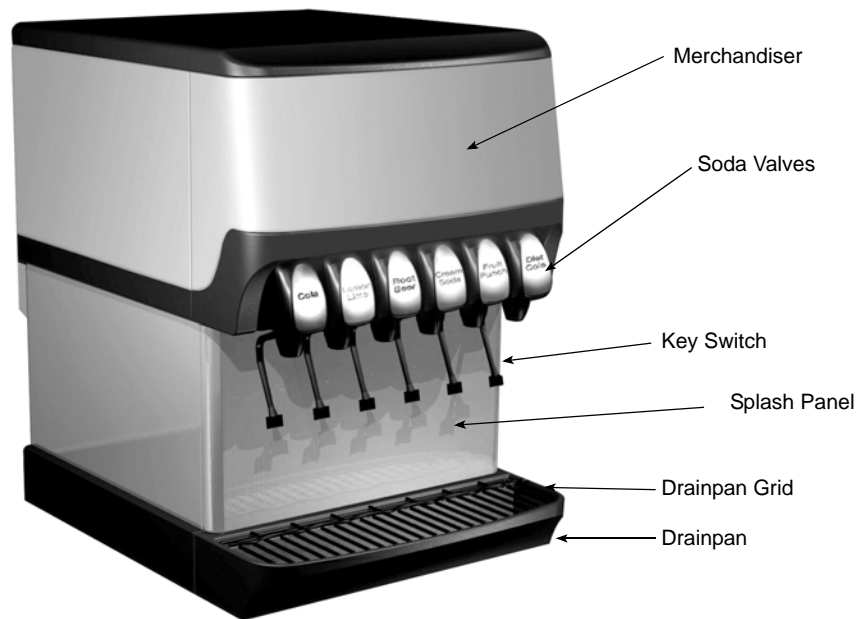

Sequence of Operation

This section gives the Counter-Electric Dispenser description, theory of operation, and service data for the 6 and 8 flavor Post Mix Dispensers (hereafter referred to as CEV.)

Important

TO THE USER OF THIS SERVICE MANUAL, THIS MANUAL IS A GUIDE FOR INSTALLING THIS EQUIPMENT. REFER TO THE TABLE OF CONTENTS FOR PAGE LOCATION FOR DETAILED INFORMATION PERTAINING TO QUESTIONS THAT ARISE DURING INSTALLATION AND START-UP OF THIS EQUIPMENT.

UNIT INSPECTION

This section covers unpacking, inspecting, selecting location, installing the CEV, and preparing for operation. Thoroughly inspect the unit upon delivery. Immediately report any damage that occurred during transportation to the delivery carrier. Request a written inspection report from a claims inspector to document any necessary claim.

1. After the unit has been unpacked, remove the keys. The key will be needed to perform brixing of valves. Hold onto the keys until such time to forward them to the respective owner/operator. Remove tape (which secures grid in place in drain pan) from grid and other packing material.

2. Make sure all items are present and in good condition. Loose shipped items in the carton include the drain kit parts and the instructions.
3. Inspect CEV for any external damages.

If you have an internal carbonated unit the unit is pre-plumbed at the factory. The inlets for CO₂ and water are located behind the splash panel. There are two inlets for water and one inlet for CO₂. If you have questions refer to the plumbing diagram on your equipment.

The outlet of the syrup supply (either BIB pump or Figal tank) connects to the appropriate syrup inlet fitting. The syrup flows through the ice bath to be chilled on its way to the valves. The water flows through the ice bath to the internal carbonator then back through the ice bath chilling the carbonated water on its way to the valves. When both fluids leave the beverage valve they are mixed in the nozzle of the valve. Out comes a properly cooled, properly ratioed soft drink.

When starting a new beverage system of either type, be sure the electrically operated valves are turned off. Make sure the voltage switch on the side of the control box is in the correct position for the voltage in the account. Assure all connections are made, turn the water supply on to the dispenser. Open CO₂ tank valve and set all pressures. Turn the refrigeration system on and allow the refrigeration coils to fill with ice. After the beverage has achieved a 40° F temperature, the ratio of the syrup-to-water (brx) on a post-mix system may then be set.

BEVERAGE VALVES

Post-mix beverage valves are designed to precisely meter the flow of both water and syrup to obtain the proper mixing ratio. The syrup and soda water components of the post-mix beverage are mixed as they leave the beverage valve.

CEVi

The CEV-30i is a 5 or 6-valve unit and the CEV-40i is an 8-valve unit, both are capable of dispensing carbonated and non-carbonated drinks. On each of these units valves 1 through 5 may be changed to carbonated or non-carbonated water by using the flex manifold, except on 5 valve units which use a 4 port manifold. The remaining valve(s) will dispense carbonated water only.

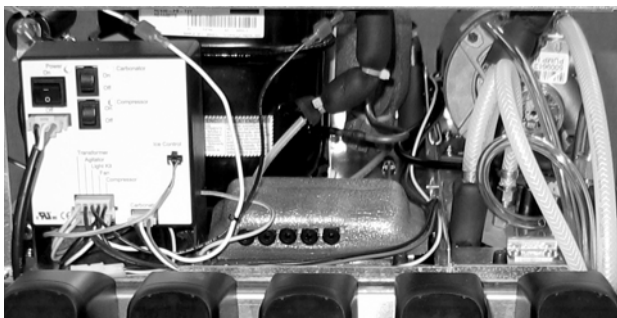

Please refer to the Recommended Plumbing section for proper use of the flex manifold.

A CO₂ cylinder delivers carbon dioxide (CO₂) gas through an adjustable CO₂ regulator to the syrup BIB pump and also to an internal carbonator. Plain water also enters the internal carbonator tank, and is carbonated by the regulated CO₂ gas pressure. When a dispensing valve is opened, CO₂ pressure exerted within the syrup BIB pump propels syrup from the BIB, through the CEV Unit beverage coils, and into the dispensing valve. Carbonated water is forced from the carbonator tank by CO₂ pressure which pushes cold carbonated water into the dispensing valve resulting in a carbonated drink being dispensed. A non-carbonated drink is dispensed in the same manner as a carbonated drink with the exception that plain water is substituted for carbonated.

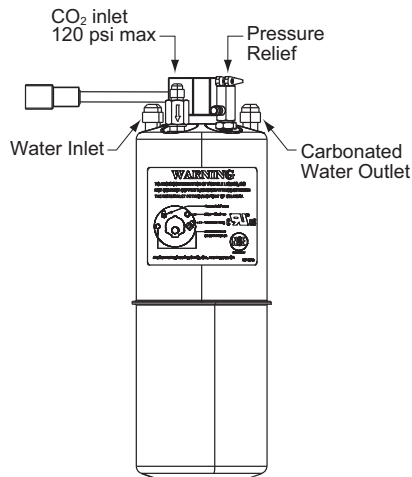

The carbonator is replenished when the carbonated water level inside the tank drops, which in turn automatically starts the carbonator water pump. When the water level inside the tank has been replenished, carbonator water pump will stop.

CEVe

The CEV-30e is a 5 or 6-valve unit and the CEV-40e is an 8-valve unit, both are capable of dispensing carbonated and non-carbonated drinks. On each of these units valves 1 through 5 may be changed to carbonated or non-carbonated water by using the flex manifold, except on 5 valve units which use a 4 port manifold. The remaining valve(s) will dispense carbonated water only.

Please refer to the Recommended Plumbing section for proper use of the flex manifold.

A CO₂ cylinder delivers carbon dioxide (CO₂) gas through adjustable CO₂ regulators to the syrup BIB pump and also to an external carbonator. Plain water also enters the remote carbonator tank, and is carbonated by the regulated CO₂ gas pressure. When a dispensing valve is opened, CO₂ pressure exerted within the syrup BIB pump propels syrup from the BIB, through the CEV beverage coils, and into the dispensing valve. Carbonated water is forced from the carbonator tank by CO₂ pressure which pushes carbonated water through the CEV cooling coils, and into the dispensing valve. Syrup and carbonated water meet simultaneously and mix at the nozzle of the dispensing valve resulting in a carbonated drink being dispensed. A non-carbonated drink is dispensed in the same manner as a carbonated drink with the exception that plain water is substituted for carbonated.

The carbonator is replenished when the carbonated water level inside the tank drops, which in turn automatically starts the carbonator water pump. When the water level inside the tank has been replenished, carbonator water pump will stop.

CEVj

The CEV-30j is a 4, 5 or 6-valve unit and is capable of dispensing non-carbonated drinks only. A CO₂ cylinder delivers carbon dioxide (CO₂) gas through adjustable CO₂ regulators to the syrup/juice BIB pump. When a dispensing valve is activated, pressure exerted upon the syrup BIB pump propels syrup/concentrate from the BIB, into the dispensing valve. Plain water enters the CEV and passes through the cooling coils to the dispensing valve. Syrup/concentrate and plain water meet simultaneously in the dispensing valve and mix at the nozzle resulting in a still (non-carbonated) drink being dispensed. The BIB syrup(s)/concentrate(s) is delivered at ambient temperature.

CARBONATED WATER

Carbon Dioxide (CO₂) leaves the storage tank and arrives at the carbonator tank through the gas inlet. Water supply enters the carbonator pump inlet at regular street water line pressure (minimum 20 psi (137.9 KPa), maximum 80 psi (551.6 KPa), dynamic or flowing pressure). The water pump increases the pressure of the water, which allows the water to flow into the carbonator tank. The CO₂ and the water mix together in the carbonator to produce the carbonated water that is then sent to the soda dispenser.

The agitation of the water and CO₂ together in the tank under high pressure creates the soda water. The quality of carbonation (percent of CO₂ mixed in the water) increases as the water temperature decreases and exposure time increases.

The water level in the carbonator tank is controlled by a water level control in the tank. This control turns the pump motor off and on to maintain a preset level of liquid in the tank. The water level control may be electronic probes or a mechanical float.

SYRUP DELIVERY SYSTEM

Your syrup location can vary depending on the volume of beverages served and ease of accessibility. Your beverage system may set in a back storage room or under the counter of the dispenser. Configurations are almost limitless. Check the temperatures expected for the storage location. Adverse temperatures can affect the storage and quality of beverage products. It is recommended the temperature of storage location should not fall below 40°F (4°C) or rise above 90°F (32°C).

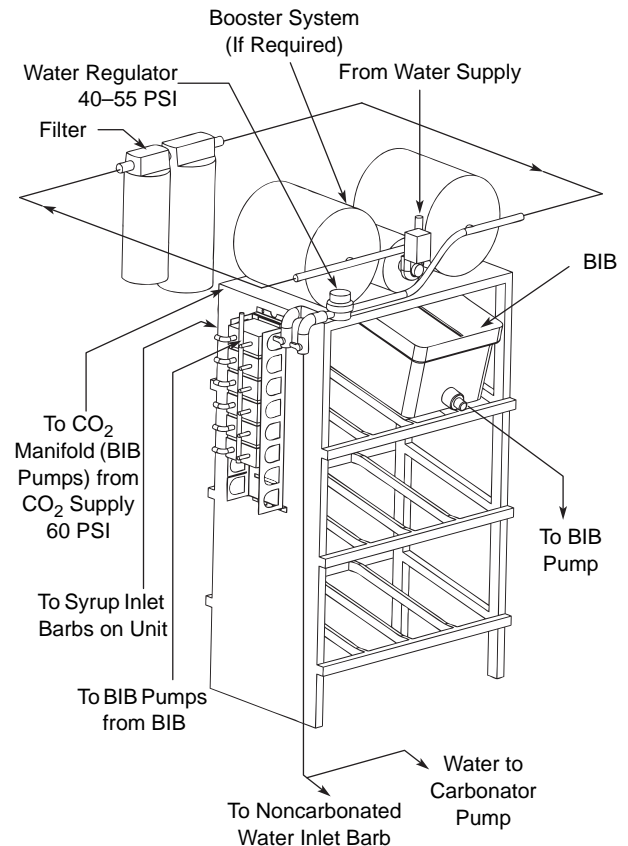
BACK ROOM PACKAGE

1. **Incoming tap water** - should be at a minimum dynamic pressure of 40 psi (275.8 KPa) and maximum static pressure of 55 psi (379.2 KPa).
2. **Carbonator Water pump motor** - Powers the water pump. The water pump motor is part of the carbonator pump deck.
3. **Carbonator Water pump** - Pumps tap water into the carbonator tank. The water pump is part of the carbonator. The incoming water for the carbonator must be first run through the pump before connecting to the proper cold plate inlet.
4. **Internal/External Carbonator tank** - Combines CO₂ gas and tap water to form carbonated water. The "carbonator" is the carbonator tank, water pump and water pump motor.
5. **CO₂ cylinder** - Holds highly pressurized carbon dioxide (CO₂). The CO₂ cylinder is a steel or aluminum cylinder tank. CO₂ gas flows through the primary pressure regulator.
6. **BIB pressure gauge** - Set for a minimum of 60 psi (413.7 KPa). Indicates CO₂ pressure going to B-I-B pumps.

7. **Primary pressure regulator** - Lowers the CO₂ gas pressure, to 100 psi (689.48 KPa), so the CO₂ gas will be at the proper pressure to enter the carbonator regulator.
8. **Lowered outgoing pressure** - Set for 75 psi (517.1 KPa). Gauge indicates lowered outgoing pressure from the CO₂ cylinder after being routed through the primary pressure regulator at 100 psi (689.4 KPa).
9. **Secondary pressure regulator** - Lowers the CO₂ gas pressure before the CO₂ gas flows to the syrup pump. CO₂ pressure activates the syrup pump.
10. **Syrup pump** - Draws syrup out of the bag-in-box syrup package. Syrup flows through the syrup lines to the dispenser for chilling, then dispensing. There is a syrup pump for each bag-in-box syrup system.
11. **Bag-In-Box syrup cartons** - Box which contains a plastic bag, filled with syrup.

FIGAL SYSTEM

Figal refers to the stainless steel tanks of pre-mix beverage or post-mix syrup. The term “Figal” is an abbreviated word. Originally Figal was short for “five gallons”. Today, the term usually refers to any stainless steel tank system used in soft drink beverage supply. The CO₂ to push the beverage from the Figal tank is sourced from a small CO₂ tank.

The stainless steel Figal beverage tanks are easy to store and connect. There are several items to remember when using the Figal tanks:

- Use a gas connector for the inlet fitting of the tank.
- Use a syrup connector for the outlet fitting of the tank.
- If more than one Figal tank is connected in series, when changing tanks, remove the tank closest to the original gas inlet while adding the new tank to the connector closest to the syrup outlet.

Most Figal tanks have a self-closing valve on the tank as well as the gas and syrup connectors. This allows the operator of the system to change tanks without having to shut down the entire system. With this type of connector, push down on the connector while pulling up on the **snap ring** around the opening of the connector. Then simply pull the connector off the tank.

RACKING

Regardless if you are working on a B-I-B or Figal system, a place will be designated for placement of the product. A rack (or shelf) system affords systematic placement and complete usage of the beverage paid for. The B-I-B rack allows the boxes to lay properly for syrup dispersal. Please check with your B-I-B syrup supplier. Some boxes must be slightly tilted down, while others may be in virtually any position. The Figal tank rack keeps the newer and full tanks organized at one end of the beverage line with the partial tanks at the other.

B-I-B

The Bag-In-Box system refers to a plastic disposable bag. The B-I-B normally contains 5 gallons of syrup, however some locations offer 2-1/2 gallon B-I-B units. This plastic bag is then held inside a cardboard or other container. B-I-B systems are for post-mix applications only.

PUMPS

The syrup in a B-I-B system is delivered to the beverage system through gas operated pumps. These pumps extract the syrup out of the bags, forcing the syrup throughout the system.

AUTO BAG SELECTORS

These are used on higher volume B-I-B systems where two or more bags of the same product are connected to one pump and one system. An auto bag selector is essentially a valve that automatically changes from one bag (or series of bags) to another bag (or series of bags) of syrup as the bags empty, allowing a constant flow of product.

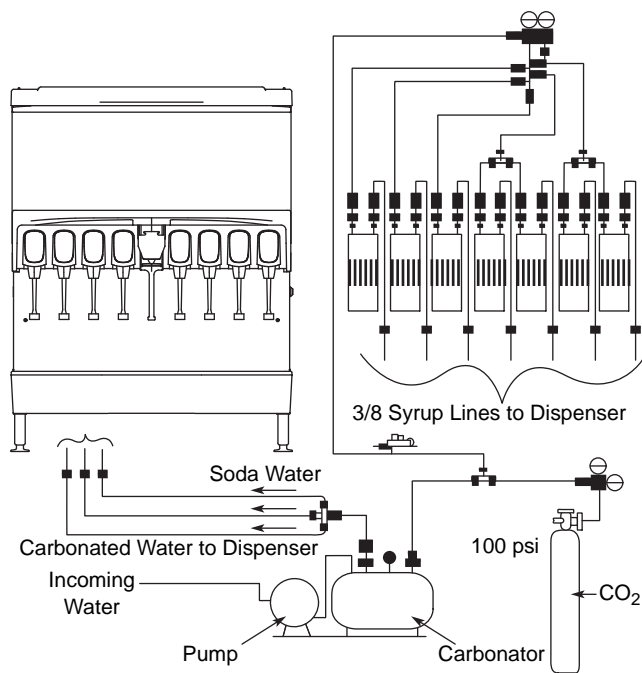

FIGAL TANKS

Operation Checks and Adjustments

ELECTRONIC ICE AND CARBONATION CONTROL

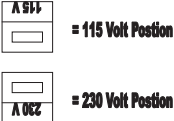
Element	Function
<p>Voltage Selection Switch (Red Side Switch)</p>  <p>= 115 Volt Position</p> <p>= 230 Volt Position</p>	<ul style="list-style-type: none"> Switch is used to select voltage, 115 Volt or 230 Volt option. When switch is in 115 Volt position the operating voltages are 100 Volts 50 Hertz and 120 Volts 60 Hertz. When switch is in 230 Volt position the operating voltages are 220-240 Volts 50 Hertz and 208-230 Volts 60 Hertz.
<p>On-Off Switch</p>	<ul style="list-style-type: none"> Switch supplies power to all control functions. When switch is in "on" position the agitation motor, transformer, merchandiser bulb and green power LED will be energized. (The green power LED will flash once per second for 5 seconds then stay on continuously.)
<p>Default Modes – LED/Default (RED)</p> <ul style="list-style-type: none"> RED Carbonator LED = Default RED Compressor LED = Default 	<ul style="list-style-type: none"> If the carbonator motor run time exceeds the preset fill times, which are (3) minutes or (7) minutes. The default mode will shut power off to carbonator pump motor for (15) minutes. It will then activate for one minute and if the motor does not shut down within the one-minute time frame the (15) minute off time and (1) minute on time default mode will repeat. The process will occur a total of (4) time and then the unit will shut down, requiring service or a manual reset. Disconnecting the power supply from unit or positioning carbonator switch to the "off" position and then returning switch to "on" position will reset control to normal operation (only applies to Internal Carb. units) If the ice bank probe does not detect water in the CEV tub the refrigeration will shut down and the compressor LED turn RED.
<p>Carbonator Switch (Switch in off position for External Carb. and Juice units, which turns off green carbonator LED.)</p>	<ul style="list-style-type: none"> Switch supplies power to the carbonator float switch and green Carbonator LED only.
<p>Green Carbonator LED (Turned off on External Carb. and Juice Units)</p>	<ul style="list-style-type: none"> The green carbonator LED illuminates when carbonator switch is in the on position. (only applies to Internal Carb. units). The green carbonator LED will flash rapidly when the carbonator motor is running.

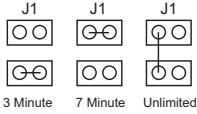
Element	Function
<p>Carbonator Fill Timing Jumper (Not used on External Carb. or Juice Units)</p>	<ul style="list-style-type: none"> Carbonator tank fill timing provides pump failure protection in the event of water loss to carbonator pump (only applies to Internal Carb. units). A jumper clip within the control box sets the three optional time settings. Units are shipped with the jumper in (7) minute position (only applies to Internal Carb. units).  <p>3 Minute 7 Minute Unlimited</p> <p>NOTE: Time tolerance is $\pm 20\%$. NOTE: See default mode functions</p>
<p>Green Compressor LED</p>	<ul style="list-style-type: none"> Illuminates when the compressor switch is in the on position. Flashes once per second when the compressor and condenser fan are energized.
<p>Refrigeration Compressor Output</p>	<ul style="list-style-type: none"> There are three wires from the ice bank probe to the control box. The white wire connects to the low ice bank probe pin (probe pin nearest evaporator coil). All three probe pins must be immersed in water to initiate the refrigeration cycle. The refrigeration system will operate until the low ice bank probe pin and center ice bank probe pin (black wire to the control box) is covered by ice. The third ice bank probe pin (probe pin farthest from evaporator coil) is the common or ground pin. The common or ground ice bank probe pin (green wire to the control box) should always be immersed in water and never in ice of ice bank. Note: A delay circuit is built into compressor and fan motor circuit. Delay is (4) minutes ($\pm 20\%$) and will prevent compressor startup if there is a power loss to the unit or the compressor switch is in "off" position and then placed in "on" position. Delay will also apply if refrigeration cycle is stopped on full ice bank and ice bank probe sends a faulty signal to restart refrigeration system within the (4) minute delay time.

Section 4 Maintenance

Cleaning

DAILY CLEANING

All cleaning must meet your local health department regulations. The following cleaning instructions are provided as a guide.

Caution

Use only warm soapy water to clean the exterior of the tower. Do not use solvents or other cleaning agents. Do not pour hot coffee into the drain pan. Pouring hot coffee down the drain pan can eventually crack the drain pan, especially if the drain pan is cold or still contains ice.

Warning

Electric Shock Hazard

Unplug unit before servicing or cleaning.

Warning

When using cleaning fluids or chemicals, rubber gloves and eye protection should be worn.

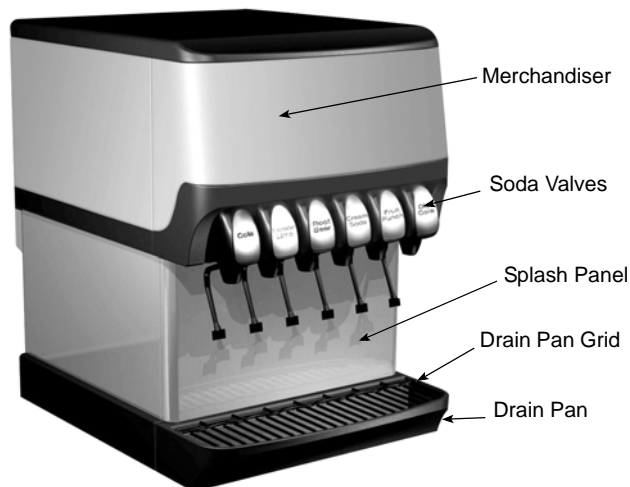

Clean the exterior and drain pan:

1. Turn off the key switch located on either right or left side of the unit.
2. Lift the grid and remove it from the drain pan.
3. Using mild soap, warm water and a clean cloth, wipe the drain pan and splash panel. Then, rinse with clean, warm water. Allow plenty of warm (not hot) water to run down the drain of the drain pan, to remove syrup residue that can clog the drain opening.
4. Wash the grid, then rinse with clean water. Place the grid back in the drain pan.
5. Wash all exterior surfaces of the unit with warm water and a clean cloth. Wipe again with a clean, dry cloth.

Clean the dispensing valves:

6. Remove nozzles and diffusers from beverage valves.

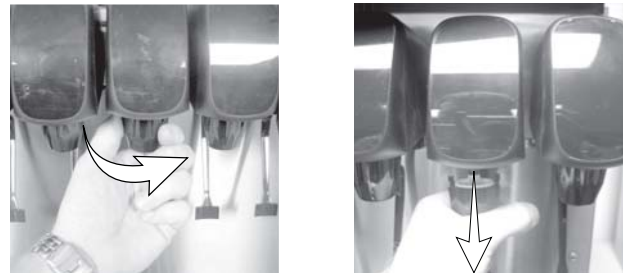

Nozzle Removal

7. Rinse nozzle and diffuser with warm, clean water.
8. Clean nozzles and diffusers with soapy water and a soft bristle brush.
9. Clean the underside of the beverage valves with warm, soapy water. Rinse with clean damp towel.
10. Replace nozzles and diffusers on valves.
11. Turn on the key switch.

WATER BATH

It is recommended that the water bath be drained at least twice a year. Turn off the refrigeration. Completely melt the ice bank. Refill the water bath with fresh water until water runs out the overflow tube. Turn on the refrigeration.

CLEANING CHECKLIST

- Check CO₂ supply. If CO₂ supply is low, an arrow on the primary regulator gauge will point to a shaded area that reads “Low CO₂” or “Change CO₂ Cylinder.”
- Check syrup supply.
- Clean drain pan, grid, and splash panel.
- Clean the valves, nozzles, and diffusers.

PREVENTIVE MAINTENANCE

Preventative maintenance is a vital part of keeping your dispenser in top condition. Following the guidelines below will assist you in continued trouble-free operation of your unit.

1. Conduct daily maintenance of the machine.
2. Perform monthly maintenance of the machine.
3. Perform periodic maintenance and sanitizing of beverage system (recommended at least twice a year).
4. Do not allow the dispenser to sit for prolonged periods of non use with ice in the bin.

Contact MBE at 1-800-367-4233 for more information about our ProActive Maintenance Program.

Sanitizing**BEVERAGE SYSTEM CLEANING** **Warning**

Flush sanitizing solution from syrup system. Residual sanitizing solution left in system could create a health hazard.

 **Warning**

When using cleaning fluids or chemicals, rubber gloves and eye protection must be worn.

Sanitize the beverage system at initial start-up as well as regularly scheduled cleaning (recommended at least twice a year). The drain pan must be in place under soda valves, to carry away detergent and sanitizing agents that will be flushed through valves.

Bag-In-Box System Sanitation

The procedure below is for the sanitation of one syrup circuit at a time. Repeat to sanitize additional circuits.

You will need the following items to clean and sanitize the Bag-in-Box (BIB) beverage system:

- Three (3) clean buckets
- Plastic brush or soft cloth
- Mild detergent
- Unscented bleach (5% Na CL O) or Commercial sanitizer
- Bag-In-Box bag connector

1. Prepare the following in the buckets:

- Bucket 1 — warm to hot tap water for rinsing.
- Bucket 2 — mild detergent and warm to hot water.
- Bucket 3 — mix a solution of unscented bleach (5% Na CL O) or commercial sanitizer and warm to hot water. Mixture should supply 100 PPM available chlorine (1/4 oz. bleach to 1 gallon water).

2. Disconnect the “syrup-line side” of the bag-in-box connector.



3. Rinse connector with warm tap water.
4. Connect syrup connector to BIB connector and immerse both into Bucket 1. A “bag-side” connector can be created by cutting the connector from an empty disposable syrup bag.

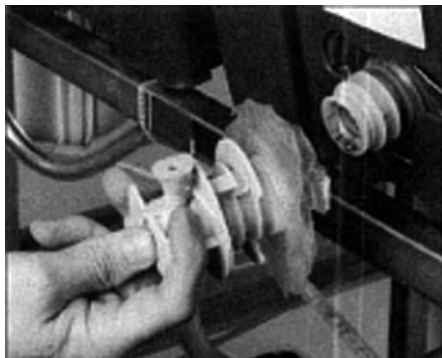
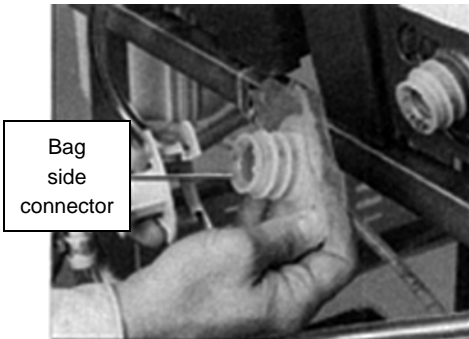

5. Draw rinse water through system until clean water is dispensed. Most beverage valves allow the syrup side to be manually activated by depressing the syrup pallet.
6. Connect Bucket 2 to system.
7. Draw detergent solution through system until solution is dispensed.
8. Repeat steps 2-7 until all syrup circuits contain detergent solution.

9. Allow detergent solution to remain in the system for 5 minutes.
10. Connect Bucket 3 to system.
11. Draw sanitizing solution through system until solution is dispensed.
12. Repeat step 11 until all syrup circuits contain sanitizer solution.
13. Allow sanitizer solution to remain in system for 15 minutes.
14. Remove nozzles and diffusers from beverage valves.
15. Scrub nozzles, diffusers and all removable valve parts (except electrical parts) with a plastic brush or a soft cloth and the detergent solution.
16. Soak nozzles, diffusers and removable valve parts (except electrical parts) in sanitizer for 15 minutes.
17. Replace nozzles, diffusers and valve parts.
18. Connect Bucket 1 to system.
19. Draw rinse water through system until no presence of sanitizer is detected.
20. Attach syrup connectors to BIBs.
21. Draw syrup through system until only syrup is dispensed.
22. Discard first 2 drinks.

Figal Beverage System

1. Prepare the following in three clean Figal tanks:
 - **Rinse tank** - fill with room temperature tap water.
 - **Detergent tank** - mix approved beverage system cleaner with warm water as directed.
 - **Sanitizing tank** - mix a solution of unscented bleach (5% Na CL O) or commercial sanitizer and warm to hot water. Mixture should supply 100 PPM available chlorine (1/4 oz. bleach to 1 gallon water).
2. Disconnect all product and water lines from product tanks and remove carbonator.
3. Locate the Figal syrup tank for the circuit to be sanitized. Remove both quick disconnects from the Figal syrup tank. Rinse quick disconnects in tap water.
4. Connect rinse tank to the syrup line. Draw clean rinse water through the valve until syrup is flushed from the system.
5. Connect detergent tank to the syrup line and draw detergent through the valve for two minutes. Then, allow remaining detergent to stay in the system for five minutes.
6. Connect rinse tank to the syrup line. Draw clean rinse water through the valve until detergent is flushed from the system.
7. Remove valve nozzle and diffuser as shown in Daily Cleaning instructions. Using a plastic brush or a soft cloth and warm water, scrub the nozzle, diffuser, bottom of the dispensing valve and cup lever, if applicable.
8. Place removable valve parts (EXCEPT solenoids) in sanitizing solution for 15 minutes.
9. Replace valve diffuser and nozzle on the beverage valve.
10. Connect sanitizer tank to the syrup line and draw sanitizer through the valve for two minutes. Allow sanitizer to remain in the system for a minimum of 15 minutes.
11. Reconnect syrup and carbonated water lines.
12. Draw syrup through the lines to rinse the system. Discard drinks until at least two cups of satisfactory tasting beverage are dispensed through the valve.

Shipping, Storage and Relocation

Caution

Before shipping, storing, or relocating this unit, syrup systems must be sanitized. After sanitizing, all liquids (sanitizing solution and water) must be purged from the unit. A freezing environment causes residual sanitizing solution or water remaining inside the unit to freeze, resulting in damage to internal components.

Section 5

Before Calling for Service

Checklist

If a problem arises during operation of your dispenser, follow the checklist below before calling service. Routine adjustments and maintenance procedures are not covered by the warranty.

DRINK TROUBLESHOOTING

Condition	Investigation	Check	Correction
Water only dispensing	No pressure	Regulator(s) out of adjustment	Check/adjust regulator(s).
		Out of CO ₂	Install fresh tank.
		Defective regulator(s)	Check/repair/replace regulator(s).
		CO ₂ line pinched, kinked or obstructed	Check/repair/replace CO ₂ line.
Syrup and CO ₂ only dispensing	Carbonator	No power	Check power supply. Plug in carbonator or reset breaker.
		Water supply	Make sure water is turned "on".
			Replace water filter.
			Check/clean/replace pump strainer.
			Check/clean/repair water check valve.
Check for frozen water line. Internal carbonator unit only.			
Defective carbonator	Check/repair/replace carbonator pump, motor, electrode or liquid level control.		
Syrup and plain water only dispensing setting	No pressure	Out of CO ₂	Install fresh tank.
		HP regulator out of adjustment	Adjust HP regulator to the proper setting.
		Defective HP regulator	Check/repair/replace HP regulator.
		CO ₂ line pinched, kinked or obstructed	Check/repair/replace CO ₂ line.
One valve will not dispense anything	Is there power to the valve?	Broken wire or loose connection	Replace/repair wire or connector.
		Bad microswitch	Replace microswitch.
Beverage dispensed is too sweet	Is the ratio (brix) of the drink correct?	Flow control out of adjustment	Adjust the flow control.
		Insufficient soda flow due to low carbonator pressure	Adjust CO ₂ pressure or change the tank.
		Low CO ₂ pressure due to leaks	Repair CO ₂ leaks.
		Obstruction in the water or soda line	Clean out the lines.
Beverage is not sweet enough	Is the ratio (brix) of the drink correct?	Flow control out of adjustment	Adjust the flow control.
		Soda flow too high	Reset CO ₂ pressure or replace regulator if necessary.
		Obstruction in syrup line	Clean out the syrup line.
Drinks are foaming	Are system pressures correct?	Over carbonation	Check CO ₂ supply. Reset pressure or replace regulator if necessary.
		Dirty lines/valves	Clean/sanitize entire system.
No water, syrup or gas dispensing	Is there power to the unit?	No power	Plug in unit or reset breaker.
		Power to control box	Replace fuse or control box.
	Is power coming through the key switch?	Key switch "off"	Turn switch "on".
		Key switch defective	Replace key switch.
	Is there power to the key switch?	No power through the transformer	Reset/replace transformer.

Pump Troubleshooting

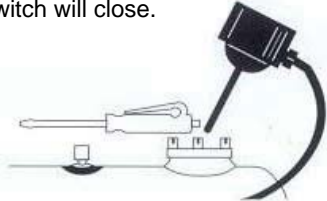
Problem	Possible Cause	Corrective Action
Pump motor does not shut off	Problem with probe or probe harness.	<ol style="list-style-type: none"> 1. Remove probe electronics. 2. Pass magnetic tip of screwdriver by lower end of tube extending from electronics package. 3. Reed switch will close. 4. 
Pump motor intermittent	Problem with probe or probe harness	
Pump motor does not pump	Water pressure from water source is not high enough	Verify water pressure leading into pump inlet is 40 psi (275.79 KPa) minimum.

PROBLEM	POSSIBLE CAUSE	CORRECTION
Pump motor does not pump.	Black and/or red probe shorted	Remove probes and bend straight or replace with new probe(s)
	Problem with motor or motor wiring	Check line voltage first. Check AC voltage across load terminals on Liquid Level Control. If voltage is 120 plus or minus 10%, replace motor or motor wiring.
	Problem with Liquid Level Control Board.	Check line voltage first. If AC voltage across load terminals is not 120 plus or minus 10%, replace the Liquid Level Control Board.
	Water pressure from water source is not high enough.	Verify water pressure leading into pump inlet is 40 psi (275.79 KPa) minimum with pump running.
Pump will not run but tank appears to be always full.	Common Lead (Green) shorted out to Red wire (High Probe)	Verify Green and Red wires are not touching.
Pump will not run but tank level appears to be below start level.	Common Lead (Green) shorted out to Black wire (Low Probe)	Verify Green and Black wires are not touching.
Pump motor does not shut off.	Problem with Liquid Level Control Board	Short the "H & L" terminals on the Liquid Level Control Board. If motor does not shut off, replace Liquid Level Control Board.
	Probe Harness Connection may be open.	Verify connections are good or replace the wiring harness.
	Water may not be reaching top probe in carb tank.	Verify tank is not filled with CO2 or air by pulling relief valve up and letting air escape until water begins coming out.
	High Lead (Red) open or not connected.	Verify Red lead wire is connected from tank to unit.
	Common lead (Green) open or not connected.	Verify Green lead wire is connected from tank to unit.

PROBLEM	POSSIBLE CAUSE	CORRECTION
Pump motor intermittent	Problem with probe or probe harness.	Check motor and motor wires by removing red and black wires from the Liquid Level Control Board. If okay, short "H & L" terminal on Liquid Level Control Board. If motor stays off, verify probes and bend straight or replace. Verify with meter.
	Problem with motor or motor wiring.	Measure AC voltage across load terminals on Liquid Level Control Board. If line voltage is 120 plus or minus 10% replace motor or motor wiring.
Pump motor intermittent	Problem with Liquid Level Control Board.	Check line voltage first. If AC voltage across load terminals on Liquid Level Control Board is not 120 plus or minus 10%, replace the Liquid Level Control board.
Pump motor starts and stops, short cycles, as soon as water level drops below Red (High) probe.	Black (Low) Lead wire is open or disconnected.	Verify connections and continuity of black wire from Liquid Level Control Board to Probes on Carb Tank.
Pump motor starts and stops, short cycles, as soon as water level drops below Black (Low) probe.	Red and Black Leads are switched with each other.	Verify Red Lead is going to Red probe and Black Lead is going to Black probe.
Pump short cycles from below high probe to just above high probe - Low probe has no effect.	Red and Green Leads are switched with each other.	Verify Red Lead is going to Red Probe and Green Lead is going to Ground Screw on tank
	Black and Green Leads are switched with each other.	Verify Black Lead is going to Black Probe and Green Lead is going to Ground Screw on tank.

THIS PAGE INTENTIONALLY LEFT BLANK

EC DECLARATION OF CONFORMITY

We hereby declare that our products, ice machines and Multiplex refrigeration equipment comply with all the essential requirements of the listed EC - directives.

Manufacturer:

Manitowoc Ice, Inc.
2110 S. 26th Street, P.O. Box 1720
Manitowoc, Wisconsin 54221-1720 USA

European Distributor:

Representative of Manitowoc Ice, Inc.:

Engineering Manager, (Printed name)

Signature

Representative of European Distributor:

Model and Serial No.

Applied EC Directives:

Applied Standards:

EN60335-1 Safety of household and similar electrical appliances
EN60335-2-24 Particular requirements refrigerators, food freezers and ice makers

EN55014 Electrical Motor Operated Appliances (Emissions)
EN55014 Electro Magnetic Compatibility (Immunity)
EN378 -1 to -4 Refrigeration Plants

Low Voltage 73/23/EEC
EMC 89/336/EEC
Pressure Equipment 97/23/EC



8201043
08/25/03

Continuing product
improvements may necessitate
change of specifications without
notice.

Part Number 020004000 10/13



MULTIPLEX[®]

Multiplex Beverage
645 Park East Blvd, Suite 5
New Albany, IN 47150
Ph: 844-724-2273 Fax: 812-246-7020
Visit us online at:
www.multiplexbeverage.com