

FreshBlender™

Integrated Beverage Systems

Service Manual

This manual is updated as new information and models are released. Visit our website for the latest manual www.welbilt.com



Safety Notices

As you work on Welbilt equipment, be sure to pay close attention to the safety notices in this manual. Disregarding the notices may lead to serious injury and/or damage to the equipment.

Throughout this manual, you will see the following types of safety notices:

Warning

Text in a Warning box alerts you to a potential personal injury situation. Be sure to read the Warning statement before proceeding, and work carefully.

Caution

Text in a Caution box alerts you to a situation in which you could damage the equipment. Be sure to read the Caution statement before proceeding, and work carefully.

Procedural Notices

As you work on Manitowoc equipment, be sure to read the procedural notices in this manual. These notices supply helpful information which may assist you as you work.

Throughout this manual, you will see the following types of procedural notices:

Important

Text in an Important box provides you with information that may help you perform a procedure more efficiently. Disregarding this information will not cause damage or injury, but it may slow you down as you work.

NOTE: Text set off as a Note provides you with simple, but useful, extra information about the procedure you are performing.

Read These Before Proceeding

Caution

Proper installation, care and maintenance are essential for maximum performance and trouble-free operation of your equipment. Visit our website www.welbilt.com for manual updates, translations, or contact information for service agents in your area.

Important

Routine adjustments and maintenance procedures outlined in this manual are not covered by the warranty.

Warning

Read this manual thoroughly before operating, installing or performing maintenance on the equipment. Failure to follow instructions in this manual can cause property damage, injury or death.

Warning

Do not use electrical appliances or accessories other than those supplied by Manitowoc for your ice machine model.

Warning

Two or more people or a lifting device are required to lift this appliance.

Warning

This equipment contains high voltage electricity and refrigerant charge. Installation and repairs are to be performed by properly trained technicians aware of the dangers of dealing with high voltage electricity and refrigerant under pressure. The technician must also be certified in proper refrigerant handling and servicing procedures. All lockout and tag out procedures must be followed when working on this equipment.

Warning

Do not damage the refrigeration circuit when installing, maintaining or servicing the unit.

⚠ Warning

Do not operate equipment that has been misused, abused, neglected, damaged, or altered/modified from that of original manufactured specifications. This appliance is not intended for use by persons (including children) with reduced physical, sensory or mental capabilities, or lack of experience and knowledge, unless they have been given supervision concerning use of the appliance by a person responsible for their safety. Do not allow children to play with this appliance.

⚠ Warning

All covers and access panels must be in place and properly secured, before operating this equipment.

⚠ Warning

Do not obstruct machine vents or openings.

⚠ Warning

Do not store gasoline or other flammable vapors or liquids in the vicinity of this or any other appliance.

⚠ Warning

Do not clean with water jet.

⚠ Warning

It is the responsibility of the equipment owner to perform a Personal Protective Equipment Hazard Assessment to ensure adequate protection during maintenance procedures.

⚠ Warning

When using electric appliances, basic precautions must always be followed, including the following:

- a. Read all the instructions before using the appliance.
- b. To reduce the risk of injury, close supervision is necessary when an appliance is used near children.
- c. Do not contact moving parts.
- d. Only use attachments recommended or sold by the manufacturer.
- e. Do not use outdoors.
- f. For a cord-connected appliance, the following must be included:
 - Do not unplug by pulling on cord. To unplug, grasp the plug, not the cord.
 - Unplug from outlet when not in use and before servicing or cleaning.
 - Do not operate any appliance with a damaged cord or plug, or after the appliance malfunctions or is dropped or damaged in any manner. Contact the nearest authorized service facility for examination, repair, or electrical or mechanical adjustment.
- g. Follow applicable lock out tag out procedures before working on equipment.
- h. Connect to a properly grounded outlet only.

THIS PAGE INTENTIONALLY LEFT BLANK

Table of Contents

Section 1 General Information

Model & Serial Numbers	9
How to Read a Model Number	9
Serial Number Location	9
Warranty Information	9
Specifications	10
Dimensions.....	10
Capacity & Weight.....	10
Product Delivery Location	11
Electrical	12
Drain Connections	13
Water Requirements	13
Supply Connections	13
Hard Water	13
System Pressures	14
Regulator Settings & Location	14

Section 2 Installation

Installation & Start-up Overview	15
Pre-installation Checklist.....	15
Connections	16
Software.....	17
Start-up & Cleaning	17
Post Installation Checklist	18

Section 3 Operation

External Component Identification	19
Sequence of Operation	19
Normal Operation	19
Product Dispense Operation.....	20
Operation	20
Ice Making.....	20
Refrigerated Cabinet Operation	22
Normal Operations	22
Evaporator & Condenser Fan Motor Operation.....	22
Operation in the Clean/Sanitize Cycle	22
Adaptive Defrost.....	22
High Temp Alarm.....	22
Fault Conditions	23
Low Water shutdown	23
Low Refrigerant Pressure shutdown	23
Power interruption	23
Rotation shutoff	23
Thermistor Failure	23

**Section 4
Maintenance**

General Maintenance..... 25
 Daily, Weekly, Monthly 25
 Quarterly & Biannual 25
 Annual, Shutdown & Start-up 25
 Door Gasket Maintenance 26
 Refrigerators 26
 Stainless Steel Care & Cleaning 26
 Doors/Hinges 27
 Preventing Corrosion 27
 Cleaning Kits 27
 Other Monthly Tasks 27
Daily Cleaning - Zone 1 28
Weekly Cleaning - Zone 2 29
Ice Maker Sanitizing & Descaling - Zone 3 & 4 29
Annual Planned Maintenance 30

**Section 5
Troubleshooting**

Store Manager Level 31
 Before Calling For Service Checklist 31
Technician Level 33
This troubleshooting is to be used only by qualified service technicians. 33
Error Log Messages 33
 Control System 34
 Ice System Troubleshooting 35
 Installation/Visual Inspection Checklist 35
 Water System Checklist 36
 REFRIGERATION SYSTEM CHECKLIST 36
 Ice Production & Quality Check 36
 Discharge Pressure High Checklist 37
 Discharge Pressure Low Checklist 37
 Suction Pressure High Checklist 37
 Suction Pressure Low Checklist 37
 Blender Controls Flowchart 38
 Blender Controls Flowchart (Continued) 39
 Ice Machine Troubleshooting Flowchart 40
Control Board Test Mode 40
Refrigerated Cabinet 41
 Refrigerated Cabinet Flowchart 41
 Ice Machine Electrical Flowchart 43
 Reach-in Temperature Out of Range 45
 High Product Temperature 46
Refrigeration System Diagnostics 47
 Refrigeration System Checklists 47
 Installation/Visual Inspection Checklist 47
 Analyzing Discharge Pressure or Temperature 47
 Analyzing Suction Pressure or Temperature 48
Water System Checklist 48

**Section 6
Controls**

Touch Screens49

- Main Select to Start Screen 49
- Drink Selection Screen 50
- Flavor Selection Screen 51
- Confirmation Screen 52
- Size Screen 53
- Employee, Managers, & Service Menu Screens 55
- Product Inventory Screen 56
- Assigning Flavors 57
- Product, Ice, & Water Calibration 59
- Shuttle Calibration 60
- Cleaning Instructions Screen 61

Other Operations62

- Loading New Menu Recipes 62
- Manual Lockout 62
- Usage Stats 62
- Service Inputs 63
- Service Outputs 63
- Machine ID 63
- Settings 63
- Logs 64
- Subsystem Version Info 64

**Section 7
Component Check Procedures**

Control System65

- ON/OFF Rocker Switch 65
- Power Relay 65
- Fan Cycle Control 66
- Ice Chute Switch 66
- Blender Control Board 67

Beverage Components68

- Blender Step Motor 68
- Blender Motor 68
- Home Position Switch 69
- Door Switches 69
- Ice Chute Switch 70
- Low water Float Switch 70
- Low Pressure Control 71
- High Pressure Cutout (HPCO) Control 71
- Gear Motor Rotation Sensor 72
- Fan Cycle Control 72
- Gear Motor Assembly 73
- Evaporator Assembly 74
- Compressor Electrical Diagnostics 74
- Diagnosing Start Components 75
- Compressor Electrical Diagnostics 75
- Compressor Drawing Locked Rotor 76
- Diagnosing Capacitors 76
- Filter-Driers 76

Refrigerated Cabinet77

Temperature Thermistor - Nozzle & Cabinet probes only.....	77
Duct Fan Motor	78
Condenser Fan Motor	78
Refrigerant Recovery/Evacuation	78
Self-Contained Model Procedure	78
System Contamination Clean-Up.....	81
General.....	81
Determining Severity Of Contamination.....	81
Cleanup Procedure	82
Replacing Pressure Controls	83

**Section 8
Charts**

Total System Refrigerant Charge	85
24-Hour Ice Production/ Refrigerant Pressure Charts.....	85
FB081TF R404A Refrigerant Chart.....	86
FB081TP R290 Refrigerant Chart	86
Nominal Operating Voltage	87
Nominal Operating Voltage for Loaded Electrical Components.....	87
Nominal Operating Voltage for Sensors	87

**Section 9
Diagrams**

Power Distribution Wiring Diagram	89
Interconnect Wiring Diagram	90
Plumbing Diagram.....	91
Ice Machine Refrigeration tubing Schematic.....	92

Section 1

General Information

Important

Only a qualified service technician must perform installation, start-up, and service of this equipment. This includes all instructions and procedures in this document.

Model & Serial Numbers

This manual covers the following models:

FreshBlender Beverage Systems
FB081TF

HOW TO READ A MODEL NUMBER

Platform	Flavors	Mixers	Plug	Refrigerant	Hinge	Optional
FB (FreshBlender)	08 (8 Flavors)	1 (1 Mixer)	T (115V 60hz)	F (R-404A)	R (Right)	Used for Build Specific Info
			B (220V 60hz)	P (R-290)	L (Left)	
			Z (Bare Lead)			
			E (Euro 16 Amp)			
			U (UK 13 Amp)			

Warranty Information

Consult your local Service Agent or Representative for terms and conditions of your warranty. Your warranty specifically excludes all general adjustments, cleaning, accessories and related servicing.

Your warranty should be activated at the time of installation/registration or a card must be returned to activate the warranty on this equipment. If either method is not completed, the warranty period can begin when the equipment leaves the Welbilt factory.

No equipment may be returned to Welbilt without a written Return Materials Authorization (RMA). Equipment returned without an RMA will be refused at Welbilt's dock and returned to the sender at the sender's expense.

Please contact your local distributor for return procedures.

SERIAL NUMBER LOCATION

The FreshBlenders beverage system serial number is listed on the serial tag affixed to the inside left and rear left of the unit.



Sample Serial Tag

NOTE: Once the unit is registered online during the startup procedure the serial number can also be found in the Service Screen under Subsystem Versions after the machine has been properly registered and a Machine ID assigned.

Specifications

DIMENSIONS

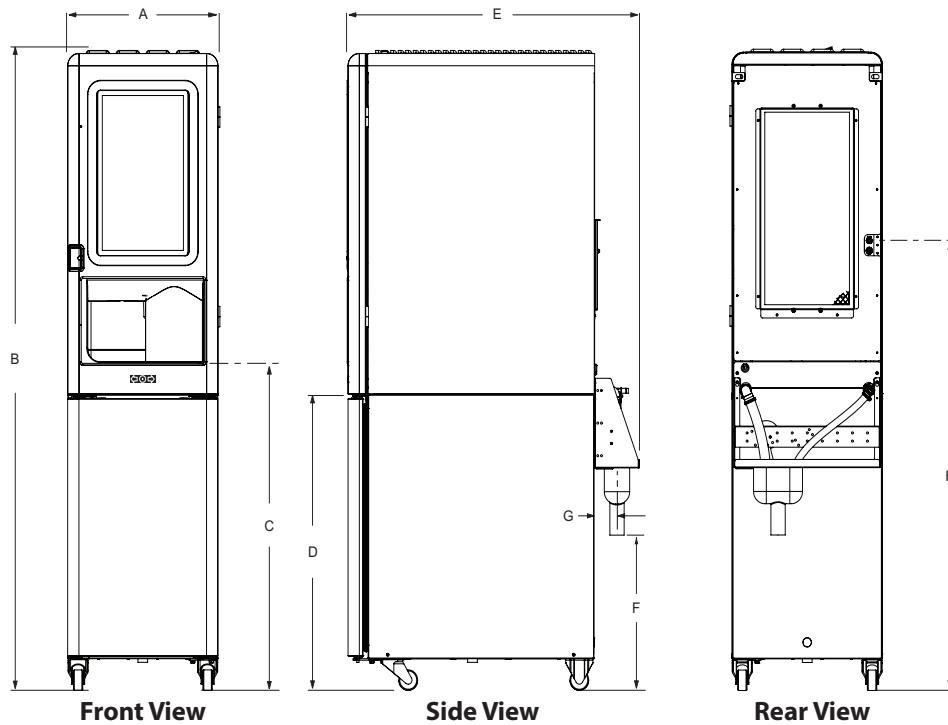

A	20.26" (52 cm)	C	40.13" (102 cm)	E	38.79" (99 cm)	G	3.08" (8 cm)
B	78.53" (200 cm)	D	35.73" (91 cm)	F	19.04" (48 cm)	H	54.35" (138 cm)

Warning

To avoid instability the installation area must be capable of supporting the weight of the equipment and a full bin of ice. Additionally the equipment must be level side to side and front to back.

CAPACITY & WEIGHT

Drink Making	Ice Capacity	Ice Compressor HP	Max Product Bin Load	Shipping Weight	Empty Weight	Full Operating Weight
1 drink in less than 2 minutes. 30 per hour up to 2 consecutive peak hours	* Up to 250 lbs (113 kg)/24 hr. Bin Storage 30 lbs (14 kg)	1/3	19.8 lbs (9 kg)	520 lbs (236 kg) Crated	400 lbs (181 kg) Unpacked No Ice/Product	560 lbs (254 kg) With Ice/Product

* Ice Capacity and Production depends on Air / Water Temperatures and Refrigerant, See 24-Hour Ice Production/ Refrigerant Pressure Charts page 85

Product Delivery Location

The location selected for the FreshBlender Beverage System must meet the following criteria.

- The air temperature must be at least 40°F (4°C), but must not exceed 90°F (32°C), climate class 4.
- The location must not be near heat-generating equipment or in direct sunlight and must be protected from weather.
- Plain Inlet Water Temperature:
min/max = 40°F / 90°F (4°C / 32°C).
- Always use the water supply line supplied when installing this appliance. Never reuse an old supply line.
- Verify floor of install location is level front to back, side to side.
- Keep equipment area clear of combustible material.

Clearances

Top	18" (46 cm)
Sides	0" (0 cm)
Back	6" (15 cm)
Front	24" (61 cm)

Warning

Do not obstruct machine vents or openings.

Heat of Rejection

Model	System BTU
FB081TF	2300 BTU/hr (average)

Electrical

⚠ Warning
 All wiring must conform to local, state and national codes.

Minimum Circuit Ampacity

The minimum circuit ampacity is used to help select the wire size of the electrical supply. (Minimum circuit ampacity is not the FreshBlender Beverage System’s running amp load.) The wire size (or gauge) is also dependent upon location, materials used, length of run, etc., it must be determined by a qualified electrician.

Voltage

A dedicated electrical circuit is required, a power cord is provided with all units. Some models are available in different voltages and may be equipped with a different plug. Refer to Fresh Blends Beverage System Model/Serial Plate for voltage/ampere specifications.

Minimum Circuit Amperage Chart

Important

Due to continuous improvements, this information is for reference only. Please refer to the serial number tag to verify electrical data. Serial tag information overrides information listed on this page.

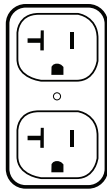

Model	Voltage/Cycle/Phase	Total Amps	Breaker Size (Min/Max)
FB081TF	120/60/1	16	20A

- Dedicated 120V 20 Amp Circuit
- Non GFI Outlet that accepts NEMA5 – 20 plug
- Outlet within 3’ (92 cm) of machine

NOTE: Supplied Cord length is 78” (198 cm).

Grounding Instructions

⚠ Warning
 The machine must be grounded in accordance with national and local electrical codes.

This appliance must be grounded. In the event of malfunction or breakdown, grounding provides a path of least resistance for electric current to reduce the risk of electric shock. This appliance is equipped with a cord having an equipment-grounding conductor and a grounding plug. The plug must be plugged into an appropriate outlet that is properly installed and grounded in accordance with all local codes and ordinances.

⚠ Warning

When using electric appliances, basic precautions must always be followed, including the following:

- A. Read all the instructions before using the appliance.
- B. To reduce the risk of injury, close supervision is necessary when an appliance is used near children.
- C. Do not contact moving parts.
- D. Only use attachments recommended or sold by the manufacturer.
- E. Do not use outdoors.
- F. For a cord-connected appliance, the following must be included:
 - Do not unplug by pulling on cord. To unplug, grasp the plug, not the cord.
 - Unplug from outlet when not in use and before servicing or cleaning.
 - Do not operate any appliance with a damaged cord or plug, or after the appliance malfunctions or is dropped or damaged in any manner. Contact the nearest authorized service facility for examination, repair, or electrical or mechanical adjustment.
- G. Follow applicable lock out tag out procedures before working on equipment.
- H. Connect to a properly grounded outlet only. See Grounding Instructions.

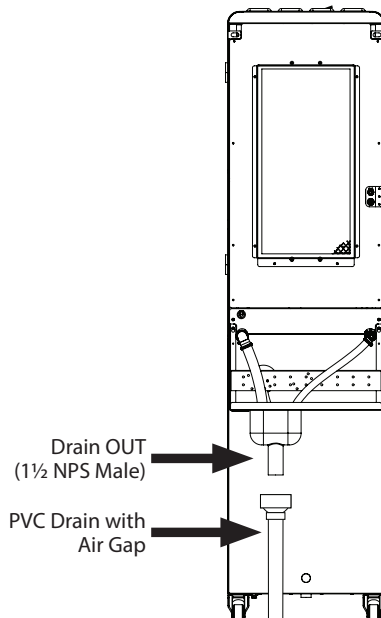
DRAIN CONNECTIONS**Models FB081TF****Drain Requirements**

- Drain lines must have a 1.5 inch drop per 5 feet of run (2.5 cm per meter), and must not create traps.
- The floor drain must be large enough to accommodate drainage from all drains.
- An air gap is required and built in to the unit for back flow prevention.

NOTE: If a PVC configuration is used a second air gap will be created.

- Always plumb to local code.

PVC DRAIN CONFIGURATION

- 4" PVC coupling to minimum 1 1/2" PVC.

FLEXIBLE DRAIN LINE CONFIGURATION

- Flexible drain line connected to the 1 1/2" NPS drain sink with service loop.

Water Requirements**⚠ Warning**

Connect to a potable filtered water supply only.

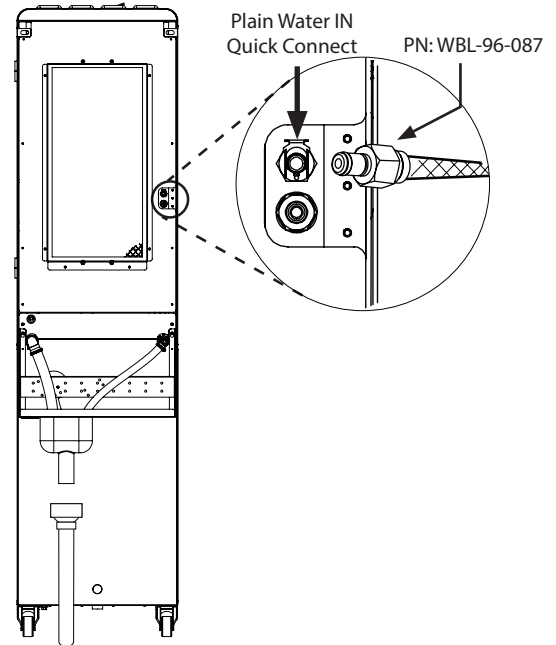
SUPPLY CONNECTIONS**Rear of the Unit**

- Use the supplied male quick connect (PN: WBL-96-087) and 6' (1.8 m) of 3/8" beverage tubing to the plain water inlet on the rear of the unit for the water supply connection.

NOTE: The 6' (1.8 m) of tubing for the water line is for a service loop to allow the unit to be serviceable if pulled out of place.

- Do not connect water to a hot water supply. Be sure all hot water restrictors installed for other equipment are working. (Check valves on sink faucets, dishwashers, etc.)
- Install a water shut-off valve in the water line at the rear of the machine.
- Insulate water inlet lines if condensation is an issue.
- Equipment to be installed with adequate back flow protection that meets all applicable national, state, and local codes.

HARD WATER

All source water must be filtered. In areas where the water is highly concentrated with minerals the water should be tested by a water treatment specialist, and the recommendations of the specialist regarding filtration and/or treatment should be followed.

SYSTEM PRESSURES

Water Supply to the Unit

⚠ Warning

Do not supply more than **80 psi** (0.551 MPa , **551** kPa, 5.51 bar) Plain or Carbonated Water to the unit, excessive pressure to product pumps may cause failure.

This table shows the Minimum / Maximum supply of Water required at the rear of the machine at no flow conditions.

	MINIMUM	MAXIMUM
Plain Water Supply	40 psi (0.276 MPa , 276 kPa, 2.76 bar)	80 psi (0.552 MPa, 552 kPa, 5.52 bar)

Important

Minimum water pressure supplied to the machine needs to be greater than the 35 psi (0.241 MPa , **241** kPa, 2.41 bar) required during flowing conditions for pressure to be regulated properly.

REGULATOR SETTINGS & LOCATION

Models FB081TF

NOTE: The regulator is located behind the left side panel.

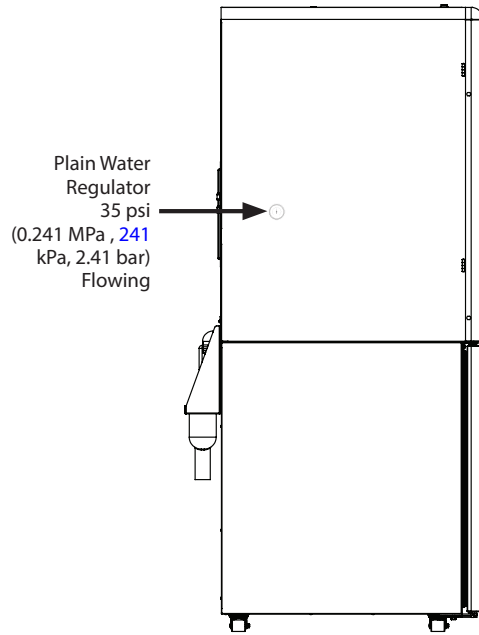

Regulator Settings

Important

Water requires the pressure measurement to be taken only when rinse water is spraying or dispensing (flowing conditions).

Important

Water pressure affects the blender area cleaning, a water booster may be required if pressure is too low.

REGULATOR	SETTINGS (During Flowing Conditions)
Plain Water	35 psi (0.241 MPa , 241 kPa, 2.41 bar)

Section 2 Installation

Installation & Start-up Overview

These instructions are provided as an overview to assist the qualified installer. Contact your Welbilt Service Agent or call Welbilt for information regarding start-up services.

Important

Failure to follow these installation guidelines may affect warranty coverage.

NOTE: Full installation instructions are included in each unit in the Installation, Operation, & Maintenance manual.

PRE-INSTALLATION CHECKLIST

- Keep product bags thawing in a cooler at least 24 hours prior to installation.
- Any damage should be noted and reported to the delivering carrier immediately.
- Check the lower portion of the unit to be sure casters are not bent.
- Visually inspect the refrigeration package, compressor compartment housing. Be sure lines are secure and base is still intact.
- Inspect installation location behind the unit for electrical outlet location, water hose fittings, and shutoff.
- Check voltage at outlet dedicated for the Fresh Blends unit.
- Verify floor of install location is level front to back, side to side and all casters are touching the floor.

⚠ Warning

The mass of this appliance will allow it to move uncontrolled on an inclined surface. Adequate means must be provided to prevent uncontrolled movement at all times.

- Remove the side panels from the unit to make the board connections, and water regulator gauge accessible.
- Check that board connections are secure and did not vibrate loose during shipment.
- Check that the micro switch is in line with the motor above the blender.

CONNECTIONS

See "Product Delivery Location" on page 11

Drain

See "Drain Connections" on page 13

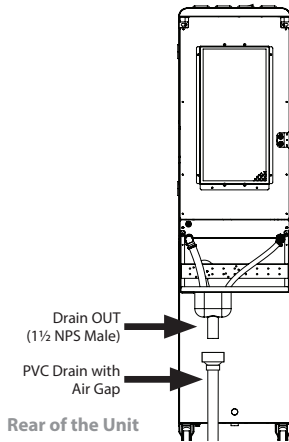

4" PVC coupling to minimum 1 1/2" PVC or Flexible drain line connected to the 1 1/2" NPS drain funnel with service loop. Drain lines must have a 1.5 inch drop per 5 feet of run (2.5 cm per meter), and must not create traps.

Important

Always and wire plumb to local, state and national codes.

Water Connection

See "Supply Connections" on page 13

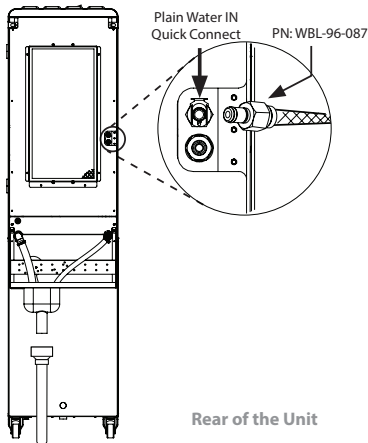

Use the supplied male quick connect (PN: WBL-96-087) and 6' (1.8 m) of 3/8" beverage tubing to the plain water inlet on the rear of the unit for the water supply connection.

Important

Water supply line needs to have an accessible water shutoff valve..

Important

Leave enough slack in the water and drain lines to allow access to the rear of the machine without disconnecting the lines.

Check regulator and set water pressure. See "System Pressures" on page 14

Important

Regulators are factory set but will need to be checked and possibly adjusted under flowing conditions once the unit is operational.

Electrical

See "Electrical" on page 12

- Dedicated 120V 20 Amp Circuit
- Non GFI Outlet that accepts NEMA5 – 20 plug
- Outlet within 3' (92 cm) of machine
- Supplied cord length 78" (198 cm)

If all electrical and grounding requirements have been followed proceed to insert electrical plug from Fresh Blends unit into wall receptacle.

Turn power switch, on the front top right of the unit, to the ON position.

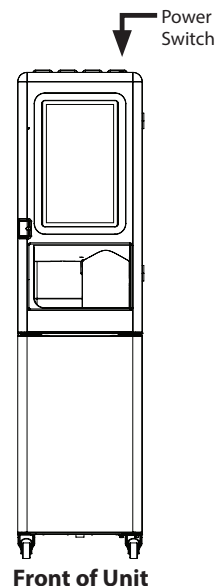

SOFTWARE

1. Verify correct UI version, firmware, drink menu, and flavors are available.

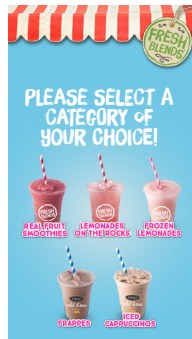

Drink Selection Screen

(Drink choices will vary depending on loaded recipe file)

START-UP & CLEANING

Important

During first time start up be sure to perform the Weekly Cleaning before loading any product through the UI, product bags will need to be in place to perform cleaning.

Checklist

Review before proceeding to Start-Up & Cleaning.

- Has all of the internal packing been removed?
- Have all of the electrical and water connections been made?
- Is there proper clearance around the machine for air circulation?
- Is the machine grounded / polarity correct?
- Has the machine been installed where the incoming water temperature will remain in the range of 40°F / 90°F (4°C / 32°C)?
- Has the regulator been properly set? This can be done/checked during cleaning.
- Has the blender splash shield sensor and shuttle positions been checked?
- Has the Power switch on the top of the unit been turned to the ON position?
- Is the correct UI, Firmware, and Menu loaded on the unit?
- Are 8 products or sanitation caps in place in the lower refrigeration cabinet prior to Zone 2 cleaning?

Clean & Sanitize

2. Perform Weekly Cleaning on the Fresh Blends machine by entering the one of the following screens, Employee, Manager, or Service Menu.

NOTE: These screens are hidden and will require a password. From a start screen, touch the three corners in the order shown below to access the password screen. Leave the field blank and Press Enter to access the Employee Menu. Manager and Service Menus require passwords.



NOTE: If the TOUCH TO START or OUT OF SERVICE screen is not currently displaying on the machine you must first enter a Flavor Selection screen then double tap the BACK button to bring the TOUCH TO START screen back up.

3. Select the Cleaning Instructions button, then Weekly (Zone 2). Clean and sanitize the Fresh Blends machine by following the on screen instructions.

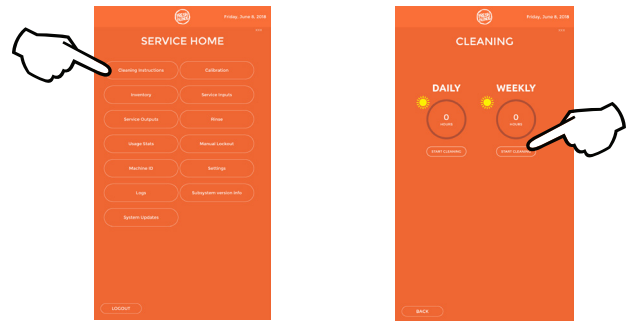

NOTE: Refer to the included Operations manual and/or on screen instructions for step by step Weekly Cleaning.

POST INSTALLATION CHECKLIST

- Has the machine been properly sanitized?
- Has each flavor been installed and primed?
- Has the plain water regulators been correctly set during flowing conditions?
- Is the machine cycling ON/OFF on the temperature control?
- Has the owner/operator been instructed regarding maintenance procedures?
- Has the owner/operator completed the warranty registration card?

4. Once completed, the FreshBlender machine is ready for use.

Section 3 Operation

External Component Identification

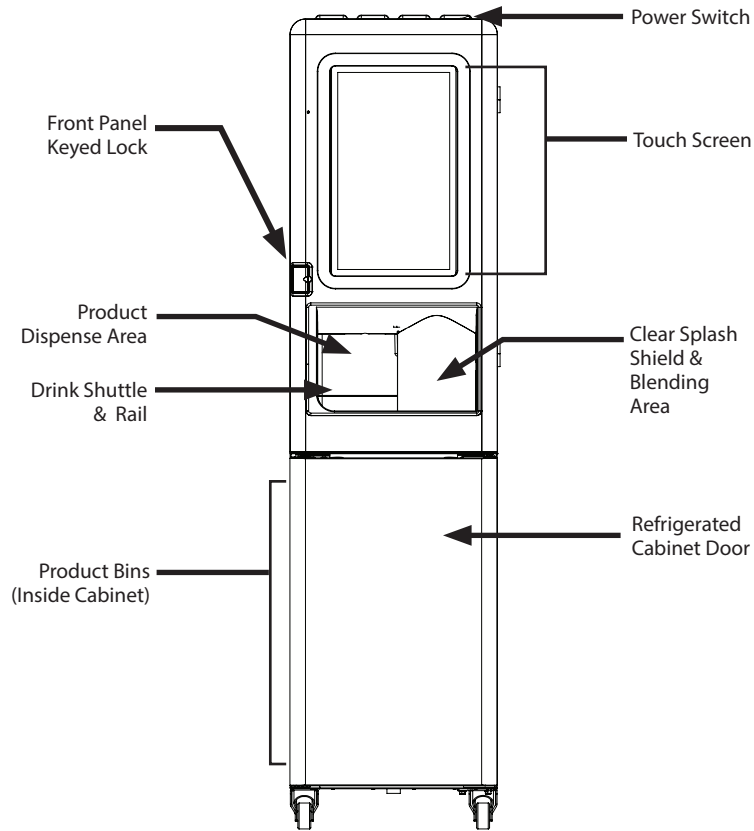

Sequence of Operation

NORMAL OPERATION

Drink Selection screen appears after power-up of the unit. Operator presses one of the drink type buttons on the Drink Selection screen, and the Flavor Options screen appears. Once a flavor is selected a confirmation screen will appear. When the user confirms the selection the on screen instructions for cup location and drink size will then display. See "Product Dispense Operation" on page 20.

With correct cup in place, the drink preparation sequence commences when "Start Drink Size" is initiated through the touch screen. The machine dispenses product and ice into the cup in the dispense area. The cup is then placed into isolated the blend chamber by the automatic shuttle system.

The machine blends the drink for the correct time at the proper blender speed. If add-ins are required for the drink after blending, the user will be prompted. The blender completes the blend sequence and the shuttle system moves the completed drink back into the dispense area where the customer can now retrieve it.

After the drink is removed the automatic rinse of the blender and dispense area initiates. The Drink Selection screen re-appears.

Default Temperature Control Setting	34°F/1°C set point 4°F/.5°C differential controlled by software
--	--

PRODUCT DISPENSE OPERATION

The sequence varies according to the recipe. Some recipes will use one ingredient, others will use multiple ingredients. The sequence below uses one ingredient to simplify the sequence.

Prerequisites:

- Line voltage must be supplied.
- Proper voltage (60V) supplied to the Stepper Motor Board.
- Product is inserted in cabinet, correctly connected to the sanitation fitting, and loaded through the UI.
- Water is supplied at the correct pressure.
- A recipe menu has been downloaded and installed to the UI.

OPERATION

Selecting a drink from the touch screen will energize the following components for the time specified by the recipe:

- The ice dispense wheel turns to add ice.
- The water dispense valve opens to dispense water, if used as an ingredient.
- Stepper motor(s) engage the product bag pump.
- The product pump(s) pump the product into the cup.

The cup is then transferred to a blending station automatically via the cup shuttle.

ICE MAKING

Main Power Switch - Front Top Right of the Unit

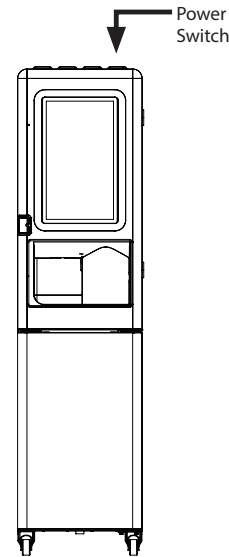

The ice machine will not start until:

1. The power ON/OFF switch is in the "ON" position.
2. Ice does not contact the bin level sensor/switch.
3. The water reservoir is full of water.
4. After 15 minute delay when power cycled.

15 Minute time delay

The 15 minute delay must be expired before the gear motor or compressor will energize.

The delay period starts to time out upon application of power or movement of the Power rocker switch from OFF to ON.

The delay period starts when:

- The ice machine enters Automatic Shutoff
- Power is disconnected and reconnected
- The water reservoir is low or empty.
- The Power rocker switch is moved from OFF to ON

This time delay period can not be overridden and will reset to 15 minutes if any of the above conditions occur.

PRIOR TO START-UP

When the Power rocker switch is placed in the ON position the following must occur in the listed order before ice making will start.

- The ice chute damper must be in the closed or down position.
- The 15 minute delay period must be expired. The delay period starts upon application of power or rocker switch movement from OFF to ON.
- The water sensing switch must be closed (water reservoir full of water and water sensing float in the up position).

INITIAL START-UP

Applying power and/or moving the rocker switch from OFF to ON will start a 15 minute delay period. This delay period can not be overridden. With the water sensing switch closed (reservoir full of water) the gear motor will energize at the end of the 15 minute time delay. The compressor and condenser fan motor energize 5 seconds after the gear motor.

FREEZE CYCLE

The float valve automatically maintains the water level in the reservoir. The ice damper will open and close to verify ice production. The ice machine will continue to make ice until the ice damper is held open (up) as ice fills the bin.

AUTOMATIC SHUT-OFF

When the ice damper is held open by ice, the gear motor, compressor and condenser fan de-energize. The fifteen minute delay period starts to time out. The ice machine will remain off until the 15 minute delay period expires and the ice damper closes.

RESTART AFTER AUTOMATIC SHUT-OFF

1. Less than 4 hours have passed since automatic shut-off.

With the water sensing switch closed (reservoir full of water) the gear motor will energize at the end of the 15 minute time delay. The compressor and condenser fan motor energize 5 seconds after the gear motor.

2. More than 4 hours have passed since automatic shut-off.

The dump valve energizes to drain the evaporator. After 30 seconds the dump valve de-energizes. When the reservoir fills with water, the water sensing switch closes and the gear motor energizes. The compressor and condenser fan motor energize 5 seconds after the gear motor.

NOTE: Ice machines use an auger to remove ice from the evaporator. Occasional noises (creaks, groans, squeaks, or pops) are a normal part of the ice making process.

Caution

Excessive noise from the ice auger may indicate a more serious issue causing the evaporator to freeze. Shut down the machine immediately and diagnose the issue.

Default Ice Maker Settings

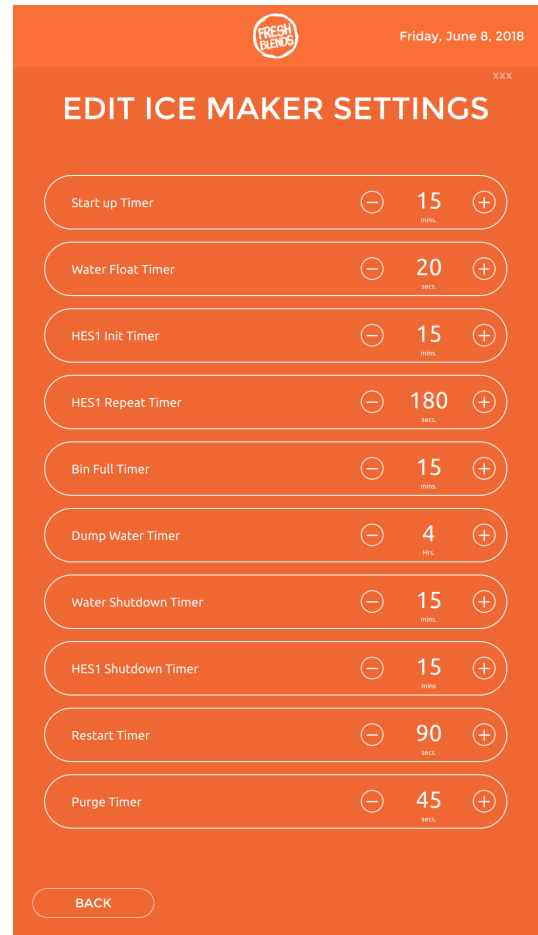

REFRIGERATED CABINET OPERATION

Default temperature set point = 1.1°C / 34° F with a 2.2°C / 4° F Differential.

Default Cabinet Settings

Setting	Value	Unit
Set Point	34	F
Differential	4	F
Min Off Time	3	mins
Defrost Run Time	240	mins
Defrost Temp	41	F
Defrost Time	15	mins
Defrost Init Temp	5	F
Default On Time	12	mins
Default Off Time	3	mins
Base Evap Fan Duty Cycle	100	%

Normal Operations

The microprocessor control board controls the cabinet temperature based on the input received from the cabinet temperature thermistor. The thermistor value is compared to the control board set point. When the reach-in temperature is equal or greater than the set point (plus half the differential), the compressor relay closes, provided the following conditions are satisfied:

- Power has been uninterrupted to the control board for a 3 minute period.

OR

- The 3 minute compressor time delay has expired. The delay period starts after the compressor has run and then cycles off.

The compressor relay opens when the reach-in temperature is less than the set point (minus half the differential).

EVAPORATOR & CONDENSER FAN MOTOR OPERATION

The condenser fan motor and compressor share the same relay. The evaporator fan motor relay is energized continuously and the evaporator fan runs continuously.

OPERATION IN THE CLEAN/SANITIZE CYCLE

During the weekly cleaning/sanitize cycle, the evaporator fan motor relay and the condenser fan motor/compressor relay remain energized.

ADAPTIVE DEFROST

After 3 hours of cumulative compressor run time, the compressor will be de-energized for fifteen (15) minutes.

HIGH TEMP ALARM

High temp alarm will display when product thermistor is above 5.5°C / 42°F for 30 minutes and the following conditions are satisfied:

- 3 hours since power is applied
- 1 hour since cleaning cycle

Error display will reset when the temperature reaches 5°C / 41°F or below.

Fault Conditions

LOW WATER SHUTDOWN

If during the ice making cycle the water drops to a point where the low float switch is open for 5 continuous seconds the compressor and evaporator gear motor de-energize. The control board starts a 15 minute time delay and energizes the SAFETY 2 LED to indicate a time delay is counting down. After the 15 minute delay the LED will de-energize and a start-up sequence will initiate.

LOW REFRIGERANT PRESSURE SHUTDOWN

If the low pressure switch is open for more than 5 continuous seconds during the ice making cycle the ice machine will shut off. The control board starts a 15 minutes time delay and the HARVEST LED energizes to indicate a time delay. After the 15 minute delay the LED will de-energize and a start-up sequence will start.

POWER INTERRUPTION

If there is a power interruption during the ice making cycle or if power is disconnected/reconnected the control board starts a 15 minute time delay period. The SAFETY 2 LED light flashes to indicate a time delay period. After the 15 minute delay the LED will de-energize and a start-up sequence will begin.

ROTATION SHUTOFF

During the ice making cycle if the rotation of the gear motor is out of range for more than 5 seconds, the rotation sensor will deactivate and stop the gear motor and compressor. A 15 minute delay will begin and the SAFETY 1 LED and rotational LED will flash. When the delay period ends the rotational LED and SAFETY 1 LED stop flashing and the ice machine begins a start-up sequence. After 8 consecutive attempts to restart, the ice machine will remain off and the SAFETY 1 LED will remain energized. The ice machine will remain off until main power is disconnected and reconnected. This will start a 15 minute delay period after which the ice machine will initiate a start-up sequence.

ICE CHUTE SWITCH

When the ice chute switch opens during the ice making cycle for 5 continuous seconds. All outputs are de-energized for 8 minutes. After the 8 minute delay the ice machine will go to startup sequence. The BIN SWITCH LED will be flashing to indicate a time delay before startup. After the 15 minute delay the yellow LED will turn off.

THERMISTOR FAILURE

If the microprocessor control board receives an open or shorted cabinet thermistor signal, the following will happen:

1. A fault is displayed on the LCD screen

- Cabinet sensor open

Or

- Cabinet sensor shorted

2. The microprocessor will initiate a default sequence for the refrigeration system - 12 minutes on, 3 minutes off.
3. The default cycle continues until the fault is corrected or power is disconnected.

THIS PAGE INTENTIONALLY LEFT BLANK

Section 4 Maintenance

General Maintenance

This section covers common unit components and their care. The chart below is an overview of the maintenance that the end user and service technician should perform, and the frequency. These figures are the minimum required. If the Ice Machine is supplied with hard water, more frequent cleaning should be performed. If the condenser air filter is totally blocked, after one week, more frequent cleaning is recommended. (X = End User, S = Service Company)

DAILY, WEEKLY, MONTHLY

Maintenance	Daily	Weekly	Monthly
Blender / Dispense Area Cleaning/ Sanitizing (Zone 1 Cleaning)	X		
Product Line Cleaning & Sanitizing (Zone 2 Cleaning)		X	
Drain Cleaning		X	
Clean Air Filters			X
Clean/Sanitize Ice Maker/Bin (Zone 3 Cleaning)			X
Descale Ice Maker/Bin (Zone 3 Cleaning)			
Clean Condenser Coil			
Inspect Ice Maker / Dispenser Parts			
Check Ice Quality	X	X	

QUARTERLY & BIANNUAL

Maintenance	3 Months	6 Months
Blender / Dispense Area Cleaning/ Sanitizing (Zone 1 Cleaning)		
Product Line Cleaning & Sanitizing (Zone 2 Cleaning)		
Drain Cleaning		
Clean Air Filters		
Clean/Sanitize Ice Maker/Bin (Zone 3 Cleaning)		
Descale Ice Maker/Bin (Zone 3 Cleaning)		S
Clean Condenser Coil	X	
Inspect Ice Maker / Dispenser Parts		
Check Ice Quality		

ANNUAL, SHUTDOWN & START-UP

Maintenance	Annual	After Prolonged Shutdown	At Start-up
Blender / Dispense Area Cleaning/ Sanitizing (Zone 1 Cleaning)			
Product Line Cleaning & Sanitizing (Zone 2 Cleaning)		X	S
Drain Cleaning		X	
Clean Air Filters		X	
Clean/Sanitize Ice Maker/Bin (Zone 3 Cleaning)		X	S
Descale Ice Maker/Bin (Zone 3 Cleaning)		S	
Clean Condenser Coil		X	
Inspect Ice Maker / Dispenser Parts	S	X	S
Check Ice Quality	S	S	S

⚠ Warning

Disconnect power to the unit before performing any service or maintenance functions.

Important

If the machine going to be shutdown for any length of time it is recommended to go through the Zone 2 - Weekly Cleaning both prior to turning off the unit and when returned to use.

If the unit is turned off, the product will no longer be kept cool in the refrigeration cabinet, remove all product bags and keep refrigerated to prevent spoilage.

DOOR GASKET MAINTENANCE

Door gaskets require regular cleaning to prevent mold and mildew buildup and also to retain the elasticity of the gasket. Gasket cleaning can be done with the use of warm soapy water. Avoid full strength cleaning products on gaskets as this can cause them to become brittle and crack. Never use sharp tools or knives to scrape or clean the gasket. Gaskets can be easily replaced and do not require the use of tools or an authorized service person. The gaskets are "Dart" style and can be pulled out of the groove in the door and new gaskets can be "pressed" back into place.

REFRIGERATORS**⚠ Warning**

Do not damage the refrigeration circuit when installing, maintaining or servicing the unit.

The interior and exterior can be cleaned using soap and warm water. If this isn't sufficient, try ammonia and water or a nonabrasive liquid cleaner. When cleaning the exterior, always rub with the "grain" of the stainless steel to avoid marring the finish. Do not use an abrasive cleaner because it will scratch the stainless steel and can damage the breaker strips and gaskets.

STAINLESS STEEL CARE & CLEANING

To prevent discoloration or rust on stainless steel, several important steps need to be taken. First, we need to understand the properties of stainless steel. Stainless steel contains 70-80% iron, which will rust. It also contains 12-30% chromium, which forms an invisible passive film over the steel's surface, which acts as a shield against corrosion. As long as the protective layer is intact, the metal is still stainless. If the film is broken or contaminated, outside elements can begin to break down the steel and begin to form discoloration or rust. Proper cleaning of stainless steel requires soft cloths or plastic scouring pads.

Important

Never Use Steel Pads, Wire Brushes or Scrapers!

Cleaning solutions need to be alkaline based or non-chloride cleaners. Any cleaner containing chlorides will damage the protective film of the stainless steel. Chlorides are also commonly found in hard water, salts, and household and industrial cleaners. If cleaners containing chlorides are used, be sure to rinse repeatedly and dry thoroughly. Routine cleaning of stainless steel can be done with soap and water. Extreme stains or grease should be cleaned with a non-abrasive cleaner and plastic scrub pad. Always rub with the grain of the steel. There are stainless steel cleaners available which can restore and preserve the finish of the steel's protective layer. Early signs of stainless steel breakdown are small pits and cracks. If this has begun, clean thoroughly and start to apply stainless steel cleaners in attempt to restore the passivity of the steel.

⚠ Caution

Never use an acid based cleaning solution! Many food products have an acidic content, which can deteriorate the finish. Be sure to clean the stainless steel surfaces of ALL food products. Common items include: tomatoes, peppers and other vegetables.

⚠ Caution

Never use a high-pressure water wash for this cleaning procedure as water can damage the electrical components located near or at the condenser coil.

DOORS/HINGES

Over time and with heavy use, doors and hinges may become loose. If this happens, tighten the screws that mount the hinge brackets to the frame of the unit. Loose or sagging doors can cause the hinges to pull out of the frame, which may damage both the doors and the hinges. In some cases this may require trained & qualified service agents or maintenance personnel to perform repairs.

NOTE: Do not place hot pans on/against the blue ABS liner. Do not throw items into the storage area. Failure to follow these recommendations could result in damage to the interior of the cabinet or to the blower coil. Overloading the storage area, restricting the airflow, and continuous opening and closing of the doors and drawers will hamper the unit's ability to maintain operational temperature.

PREVENTING CORROSION

Immediately wipe up all spills.

CLEANING KITS

Freshblends Stera-sheen starter cleaning kit (part number WBL-40-001-FRU).

These kits include the following:

- 2.5 gal Shaker Jug
- CIP Intake Line
- Two 4lb Jars of Stera-sheen Cleaner/Sanitizer
- Cups for blender cleaning
- 32 oz Spray Bottle
- Chlorine Test Strips
- Ice Removal Chute Assembly *

* Item included in with unit but not part of cleaning kit 000-BIC-0001Q

OTHER MONTHLY TASKS

Air Filters

Each month check the air filters to be sure they are clean and allow proper airflow.

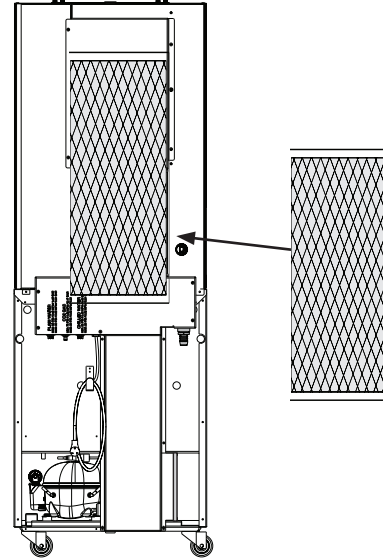

Air Filter Locations

First access the rear of the unit. Slide them out one at a time and inspect them. If they are dirty or light will not pass through them when held up to light, take to a sink and wash with dish soap until clean. DO NOT put in a dishwasher.

Once clean, slide them back into place on the unit and move unit back into place.

Cleaning the Condenser Coil

In order to maintain proper refrigeration performance, the condenser fins must be cleaned of dust, dirt and grease regularly. It is recommended that this be done at least every three months. If conditions are such that the condenser is totally blocked in three months, the frequency of cleaning should be increased. Clean the condenser with a vacuum cleaner or stiff brush. If extremely dirty, a commercially available condenser cleaner may be required.

Failure to maintain a clean condenser coil can initially cause high temperatures and excessive run times. Continuous operation with a dirty or clogged condenser coil can result in compressor failure. Neglecting the condenser coil cleaning procedures will void any warranties associated with the compressor and cost to replace the compressor.

Caution

Never use a high-pressure water wash for this cleaning procedure as water can damage the electrical components located near or at the condenser coil.

Daily Cleaning - Zone 1

Zone 1 daily cleaning is accessed through the cleaning screen. The Cleaning screen appears after selected from the Main Menu or when prompted to perform routine cleaning. This screen's primary function is to perform routine cleaning and sanitation of the machine. It covers the basic components of the FreshBlender that will need cleaned on a daily basis.

NOTE: The on-screen instructions can vary depending on the firmware version of the machine and can vary slightly per customer. All Zone 1 cleaning steps are covered in the Installation Operation & Maintenance manual that ships with the unit.

- Time to complete - 15 minutes
1. This is done through the Employee, Managers, or Service Screen options.



2. In the Cleaning screen select the button under DAILY.



Exterior Cleaning

Remove dust and dirt from the exterior surfaces with a mild household dish washing detergent and warm water. Wipe dry with a clean, soft cloth.

Use cleaners designed for use with stainless steel products.

Heavy stains should be removed with stainless steel wool. Never use plain steel wool or abrasive pads. They will scratch the panels.

Plastic exterior panels and UI (User Interface) Screen should be cleaned with a mild household dish washing detergent and warm water on a damp cloth. Wipe dry with a clean, soft cloth.

Weekly Cleaning - Zone 2

Zone 2 weekly cleaning is accessed through the cleaning screen. The Cleaning screen appears after selected from the Main Menu or when prompted to perform routine cleaning. This screen's primary function is to perform routine cleaning and sanitation of the machine. It covers the basic components of the FreshBlender that will need cleaned on a daily basis.

NOTE: The on-screen instructions can vary depending on the firmware version of the machine and can vary slightly per customer. All Zone 2 cleaning steps are covered in the Installation Operation & Maintenance manual that ships with the unit.

- Time to complete - 90 Minutes

1. This is done through the Employee, Managers, or Service Screen options.



2. In the Cleaning screen select the button under WEEKLY.



NOTE: Failure to complete the weekly cleaning sequence entirely will not reset the weekly cleaning timer and will require the process to be repeated.

Ice Maker Sanitizing & Descaling - Zone 3 & 4

Sanitizing is recommended every six (6) months. More frequent sanitizing or descaling may be required in some existing water conditions. Follow carefully any instructions provided with the bottles of Ice Machine Descaling or sanitizing solution.

Warning

Always wear liquid-proof gloves to prevent the descaling and sanitizing solutions from coming into contact with skin.

NOTE: All steps will be displayed on screen.

- Time to complete - 2 hours

Descaling is a choice during Zone 3 Ice Maker Sanitizing. Or can be performed by itself in Zone 4 Descaling.

Important

Only a trained manager or authorized technician should access the service screens. If changes to these settings are made incorrectly they can cause the unit to malfunction or not work at all.

NOTE: Failure to complete the Zone 3 or 4 cleaning sequence in its entirety could affect drink quality and will not reset the cleaning timer which will require the process to be repeated.

Annual Planned Maintenance

The following parts are recommended for annual planned maintenance replacement to ensure optimum unit performance and minimize downtime:

- Refrigerator door gasket (cleaning may be sufficient)
- Two (2) #6 O-rings for the water and CIP hose quick connect lines
- Blender Shaft Assemblies

The evaporator for the on board ice maker should be inspected at least once a year. The evaporator service life also depends on the water quality and environment. More frequent inspection and maintenance are recommended to keep performance of this ice maker optimized.

NOTE: All planned maintenance must be done by an approved, certified Manitowoc Field Service Technician.

Section 5 Troubleshooting

Store Manager Level

The checklist below can be used by a store manager or used to verify a manager has done before calling service. Routine adjustments and maintenance procedures are not covered by the warranty.

BEFORE CALLING FOR SERVICE CHECKLIST

Symptom	Possible Cause	Corrective Action
Display Screen is off or refrigeration system is not running	Fuse blown or circuit breaker tripped.	Replace fuse or reset circuit breaker.
	Power cord unplugged.	Plug in power cord.
	Thermostat set too high.	Set thermostat to lower temperature.
	Main power switch turned off.	Turn main power switch on.
Display screen is on, but does not respond to commands	No recipe installed.	Develop recipe in MenuConnect and transfer to control system with USB drive.
	Control board locked up.	Reboot by disconnecting and reconnecting the main power supply.
Recipe does not dispense correctly	No water supply or Low water pressure.	Restore water supply, set regulator to correct pressure. See "Connections" on page 16.
	Product is not installed, is installed incorrectly.	Install product, re-install correctly..
	Ice does not dispense.	Call for service.
Blender does not start or blend	Door is not closed, or shield isn't in place.	Close blender door, replace splash shield.
	Blender door switch is not closing.	Call for service.
Compressor runs for long periods or continuously	Excessive amount of warm product placed in cabinet.	Allow adequate time for product to cool down.
	Prolonged door openings or door(s) ajar.	Make sure door(s) are closed when not in use. Avoid prolonged door openings.
	Door gasket(s) not sealing properly.	Check gasket condition. Adjust door or replace gasket if necessary.
	Dirty condenser coil.	Clean the condenser coil.
	Evaporator coil iced over.	Turn unit off and allow coil to defrost. Make sure thermostat is not set too cold. Also, check gasket condition.

Symptom	Possible Cause	Corrective Action
Cabinet temperature is too high	Thermostat set too high.	Set thermostat to lower temperature.
	Evaporator Fan(s) will not operate or fan blade is off or spinning on shaft.	Call for service.
	Excessive amount of warm product placed in cabinet.	Allow adequate time for product to cool down.
	Prolonged door openings or door(s) ajar.	Make sure door(s) are closed when not in use. Avoid prolonged door openings.
	Dirty condenser coil.	Clean the condenser coil.
	Evaporator coil iced over.	Turn unit off and allow coil to defrost. Make sure thermostat is not set too cold. Also, check door gasket condition.
	System low on refrigerant.	Call for service - Service company must locate and repair leak, recover, evacuate and recharge.
	Compressor will not start - hums and trips on overload protector.	Clean the condenser coil. Move cabinet or make other adjustments to gain proper cabinet clearances. See "Pre-installation Checklist" on page 15. Check and correct incoming voltage to cabinet.
Cabinet is noisy	Loose part(s).	Locate and tighten loose part(s).
	Tubing vibration.	Ensure tubing is free from contact with other tubing or components.
Refrigerator is freezing product	Thermostat is set too low.	Set thermostat to higher temperature. See "Settings" on page 63.

Technician Level

This troubleshooting is to be used only by qualified service technicians.

Error Log Messages

CONTROL SYSTEM

Will Not Run Diagnostics

⚠ Warning

High (line) voltage is present when the back and side panels are removed.

1. Verify primary voltage is supplied at the plug.
2. Reboot by disconnecting and reconnecting the main power supply.
3. Verify ON/OFF rocker switch functions properly and supplies line voltage to power relay coil (T1 - T0).
4. Verify power relay contacts are closed (T2 -T4 and T6 - T8).
5. Verify line voltage is present at the 24 VDC power supply primary - CN1.
6. Verify 24 VDC is present at the power supply secondary - CN2.
7. Verify in-line 4 amp fuse on 24 VDC supply is closed - CN2 T1.
8. Verify 24 VDC is present at SRB board MTA2 (J1) connector. Disconnect and reconnect wiring to verify connection.
9. Duct fan, cabinet refrigeration or ice machine operating?
 - No - Replace SRB board.
 - Yes - Go to next step.
10. User Interface (UI) energized?
 - No - Inspect wiring, disconnect and reconnect wiring to verify connection, replace UI.
 - Yes - Go to next step.
11. Does UI progress through screens?
 - No - Reload Firmware and Recipe File
See "Software" on page 17.
 - Yes - Go to next step.
12. Do any components energize during the drink making sequence?
 - No - Replace SRB board.
 - Yes - Troubleshoot non functional component. If blender is non functional proceed to Blender Motor section.

13. 24 VDC on Motor Controller Board MTA2 (J1)?
 - No - Replace wire.
 - Yes - Go to next step.
 14. Home position switch closed on motor controller circuit board Home SWT (J13)?
 15. Door switch circuit closed on motor controller circuit board Door SWT (J9)?
 16. Door switch circuit closed and supplying 24 VDC to coil on DPDT relay?
 17. Blade DPDT relay contacts closed?
 18. AC voltage present at J5, J6 of Motor Controller Board?
 - No – Voltage present at J15, J16 (Left Motor) J11, J12 (Right Motor) on the SRB?
 - No – Check wiring
 - Yes – Go to next step
- NOTE: Motor can be tested either in the Service Menu under the OUTPUTS Right Blade or Left Blade selection (See "Employee, Managers, & Service Menu Screens" on page 55) or within the Drink Menu selection Blend Only option (See "Drink Selection Screen" on page 50). Testing the motor in the Service Menu will provide half voltage for 3 seconds to the motor. Testing the motor in the Make Drink Menu should provide full voltage to the motor for a longer period of time determined by the recipe file.
19. When called for activation as mentioned in above note is AC voltage present at J2, J7 of the Motor Control Board?
 - No – Replace Motor Control Board
 - Yes- Go to next step
 20. Blade motor running?
 - No - Test capacitor - Replace blade motor.
 - Yes - Go to next step.
 21. Step motor operates?
 - No - Replace motor.

NOTE: Both blender assemblies will require testing.

ICE SYSTEM TROUBLESHOOTING

- Ask these questions before beginning service:
- When does the ice system malfunction? (Normal operation, after a cleaning cycle, etc.)
- When do you notice low ice production? (One day a week, every day, etc.)
- Can you describe exactly what the ice system seems to be doing?
- Has anyone been working on the ice machine? (Has anyone turned the switch off on the back of the unit?)
- Is there any reason why incoming water pressure might rise or drop substantially?

Ice Machine Fault Conditions

LOW WATER SHUTDOWN

If during the ice making cycle the water drops to a point where the low float switch is open for 5 continuous seconds the compressor and evaporator gear motor de-energize. The control board starts a 15 minute time delay and energizes the SAFETY 2 LED to indicate a time delay is counting down. After the 15 minute delay the LED will de-energize and a start-up sequence will initiate.

LOW REFRIGERANT PRESSURE SHUTDOWN

If the low pressure switch is open for more than 5 continuous seconds during the ice making cycle the ice machine will shut off. The control board starts a 15 minute time delay and the HARVEST LED energizes to indicate a time delay. After the 15 minute delay the LED will de-energize and a start-up sequence will start.

POWER INTERRUPTION

If there is a power interruption during the ice making cycle or if power is disconnected/reconnected the control board starts a 15 minute time delay period. The SAFETY 2 LED light flashes to indicate a time delay period. After the 15 minute delay the LED will de-energize and a start-up sequence will begin.

ROTATION SHUTOFF

During the ice making cycle if the rotation of the gear motor is out of range for more than 5 seconds, the rotation sensor will deactivate and stop the gear motor and compressor. A 15 minute delay will begin and the SAFETY 1 LED and rotational LED will flash. When the delay period ends the rotational LED and SAFETY 1 LED stop flashing and the ice machine begins a start-up sequence. After 8 consecutive attempts to restart, the ice machine will remain off and the SAFETY 1 LED will remain energized. The ice machine will remain off until main power is disconnected and reconnected. This will start a 15 minute delay period after which the ice machine will initiate a start-up sequence.

Ice Chute switch

When the ice chute switch opens during the ice making cycle for 5 continuous seconds, all outputs are de-energized for 8 minutes. After the 8 minute delay the ice machine will go to a startup sequence. The BIN SWITCH LED will be flashing to indicate a time delay before startup. After the 15 minute delay period the yellow LED will turn off

Overriding ice machine time delay

In the Service Home > Settings > Ice Maker screen you can reduce the startup time to as little as 3 minutes. Be sure to set the default back to 15 minutes when done..

INSTALLATION/VISUAL INSPECTION CHECKLIST

Possible Problem List	Corrective Action List
Condenser filter is dirty.	Clean the condenser filter.
Airflow through top half of the machine is restricted.	4 inch clearance in back and 18 inch clearance on top of unit is required. (See "Store Manager Level" on page 31)
Noise from the evaporator	Clean the ice machine, excessive operational noise is normally corrected by cleaning. Overnight soaking will be required on infrequently cleaned machine.
Water filtration is plugged (if used)	Install a new water filter.

WATER SYSTEM CHECKLIST

A water-related problem could cause component misdiagnoses. Water system problems must be identified and eliminated prior to replacing other components.

Possible Problem List	Corrective Action List
Water supply pressure not between 40 and 80 psig.	Check water supply pressure & regulator Settings.
Water regulator(s) on the unit must be set to 35psig dynamic.	Check regulator setting and adjust to 35 psig pressure.
Incoming water temperature is not between 45°F (1.7°C) and 90°F (4 C/ 32.2°C)	If too hot, check the hot water line check valves in other store equipment.
Water filtration is plugged (if used)	Install a new water filter.
Hoses, fittings, etc., are leaking water.	Repair/replace as needed.
Water float valve is stuck open or closed.	Clean/replace as needed.
Ice Chute safety switch stuck open or closed	Clean/replace if needed.
Water probes in header tank are not detecting water.	Short probes to check. Clean probes.
Water probes in header tank are not detecting water.	Short probe cable out at board connection. Replace cable if needed.
Was Zone 3 or 4 Ice Maker Cleaning just performed?	Allow time for restart and ice production, check for frozen evaporator..

REFRIGERATION SYSTEM CHECKLIST

Installation/visual inspection checklist	
Inadequate Clearances	Check all clearances on sides, back and top
Condenser is dirty	Clean the condenser
Inadequate Water supply	Refer to water system checklist
Ice machine is dirty	Clean ice machine - excessive operational noise will normally be corrected with cleaning. Infrequent cleaning may need an overnight soak with ice machine cleaner to remove all lime/scale deposits.

ICE PRODUCTION & QUALITY CHECK

Ice Production

1. Empty the ice from the unit by starting Zone 3 cleaning which dumps ice for 4 minutes.
2. Remove the ice bin lid, remove the ice dispense drive shaft / agitator.
3. Run the ice machine a minimum of 10 minutes to allow the system to stabilize.
4. Measure the air temperature entering the condenser and the water temperature entering the unit (with insulated probe).
5. Weigh a dry, non-perforated container that will fit in the ice bin to catch the ice.
6. Catch the ice in container for 7 minutes and 12 seconds (approximately 1 kg) or, for more accuracy, 14 minutes and 24 seconds (approx. 2 kg).
7. Weigh the container and ice, and then deduct the weight of the container.
8. Determine the 24-hour ice production capacity.
 - 7 minutes 12 seconds: Multiply the total ice weight by 200.
 - 14 minutes 24 seconds: Multiply the total ice weight by 100.

Quality

Ice production will vary with ambient and water temperatures.

Higher incoming water temperature results in lower ice production quantity.

Lower water temperature results in higher ice quantity.

EXAMPLE:

1. Collected ice for 7 minutes 12 seconds.
2. Total weight (minus container) = 0.95 kg.
3. $0.95 \text{ kg} \times 200 = 190 \text{ kg}$ of ice every 24 hours.
4. Compare the capacity to the 24-hour ice production chart for the conditions being tested.
5. Ice production checks that are within 10% of the charted capacity are considered normal due to variances. Actual temperatures will seldom match the chart exactly. Please See "24-Hour Ice Production/ Refrigerant Pressure Charts" on page 85 for charts on acceptable ice production.

DISCHARGE PRESSURE HIGH CHECKLIST***Air Condenser***

- Dirty condenser filter
- Dirty condenser fins
- High inlet air temperature
- Condenser discharge air recirculation
- Defective fan cycling control
- Defective fan motor

Other

- Overcharged
- Non-condensable (air) in system
- Wrong type of refrigerant
- Non-OEM components in system
- High side refrigerant lines/component restricted

DISCHARGE PRESSURE LOW CHECKLIST***Air Cooled Condensers***

- Defective fan cycle control, stuck closed

Other

- Undercharged
- Wrong type of refrigerant
- Non-OEM components in system

SUCTION PRESSURE HIGH CHECKLIST***Improper Installation***

- Refer to "Installation/Visual Inspection Checklist"

Discharge Pressure

- Discharge pressure is too high and is affecting suction pressure

Improper Refrigerant Charge

- Overcharged (also see "Freeze Cycle Discharge Pressure High Checklist")
- Wrong type of refrigerant
- Non condensible in system

Components

- TXV flooding
- Defective compressor

Other

- Non-OEM components in system

SUCTION PRESSURE LOW CHECKLIST***Improper Installation***

- Refer to "Installation/Visual Inspection Checklist"

Discharge Pressure

- Discharge pressure is too low and is affecting low side – refer to "Freeze Cycle Discharge Pressure Low Checklist"

Improper Refrigerant Charge

- Undercharged
- Wrong type of refrigerant

Other

- Non-OEM components in system
- Restricted/plugged liquid line drier
- Restricted/plugged tubing in suction side or liquid line of refrigeration system
- TXV starving

BLENDER CONTROLS FLOWCHART (CONTINUED)

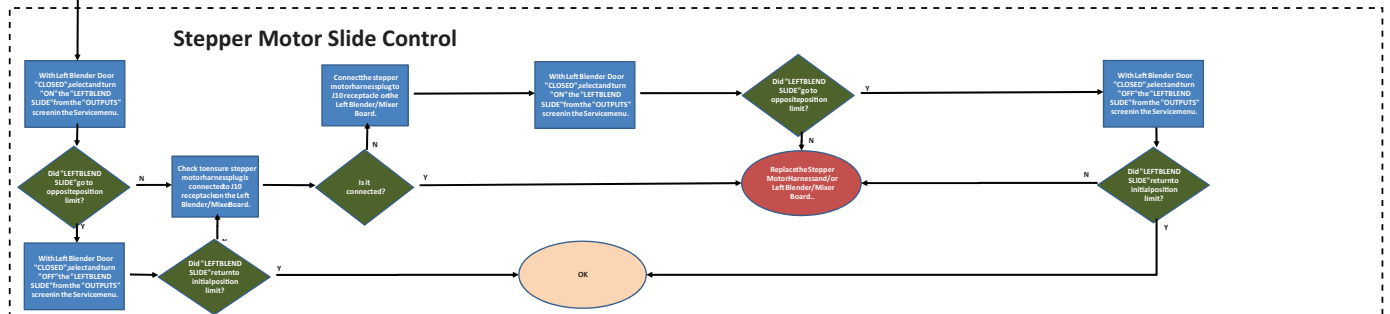
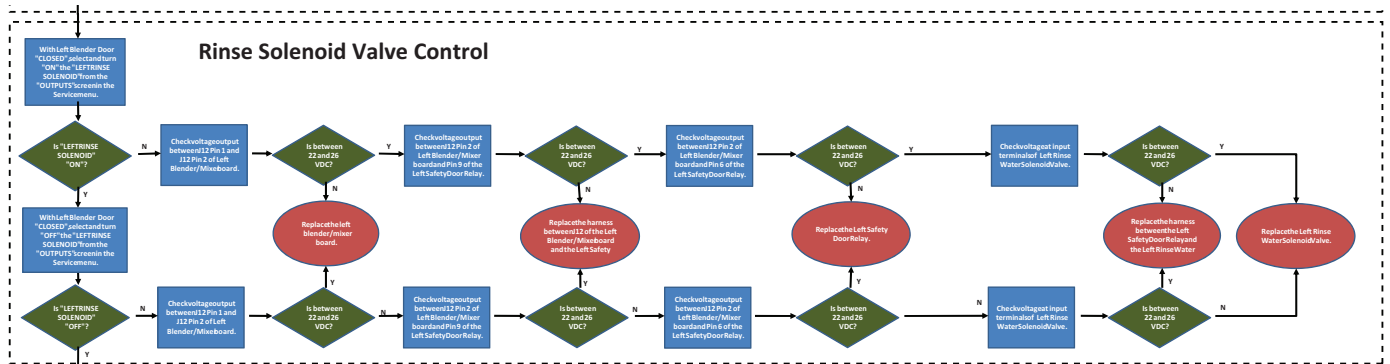

ICE MACHINE TROUBLESHOOTING FLOWCHART

Yes = Continue	No = Check	Remedy
Ice machine rocker switch in ice position?	There is an independent switch for the ice machine	Move rocker switch to on position, refer to rocker switch diagnostics
Energized lights on ice machine control board?	Check for power to 55 & 56 on the ice machine control board.	Verify connections from BIC master control relay (MCR)
Delay period expired?	Full bin or rocker switch turned off = 8 minute delay Fault or power interruption = 15 minute delay	Wait for delay to expire
Bin Level Light on?	Ice may be in chute or the switch may not move freely.	Refer to ice chute diagnostics
Harvest light is off?	Attach refrigeration gauges and test run to check pressure	Below 15 psi locate and repair refrigerant leak. Above 15 psi refer to low pressure control diagnostics
Safety limit 2 light off?	No water in reservoir	Restore water, test float valve operation
Gear motor energized?	Check contactor coil for power, check contacts, test gear motor	Replace contactor or gear motor
Time delay light on evaporator is solid yellow after 11 seconds?	Red blinking is 15 minute time delay Red solid is lockout	Clean ice machine and refer to time delay operation
Compressor starts when the 11 second time delay ends?	Check contactor coil for power, check contacts, test gear motor	Replace contactor or gear motor
	HPCO open Attach refrigeration gauge set and test run to check pressure.	Clean filter and/or condenser, refer to HPCO
	BIC clean in place (CIP) Relay contacts must be closed	Test CIP relay
	Time delay light on evaporator is red	Check HPCO, Clean lime scale and minerals from evaporator and sanitize
Compressor continues to run after 3 minute fault override period?	Determine which fault is shutting the machine off	Refer to fault conditions
Ice machine stops on bin switch?	Ice machine must stop on full bin	Refer to bin switch operation

Control Board Test Mode

- A. Place the rocker switch in the OFF position.
- B. Press the control board TEST button for 3 seconds.
- C. The gear motor starts and 3 seconds later the compressor starts.
- D. All LEDs and relays energize for 30 seconds, then de-energize.
- E. Moving the rocker switch to the ice position will initiate a start-up sequence without a time delay period. This method can be used to bypass the time delay.

Refrigerated Cabinet

REFRIGERATED CABINET FLOWCHART

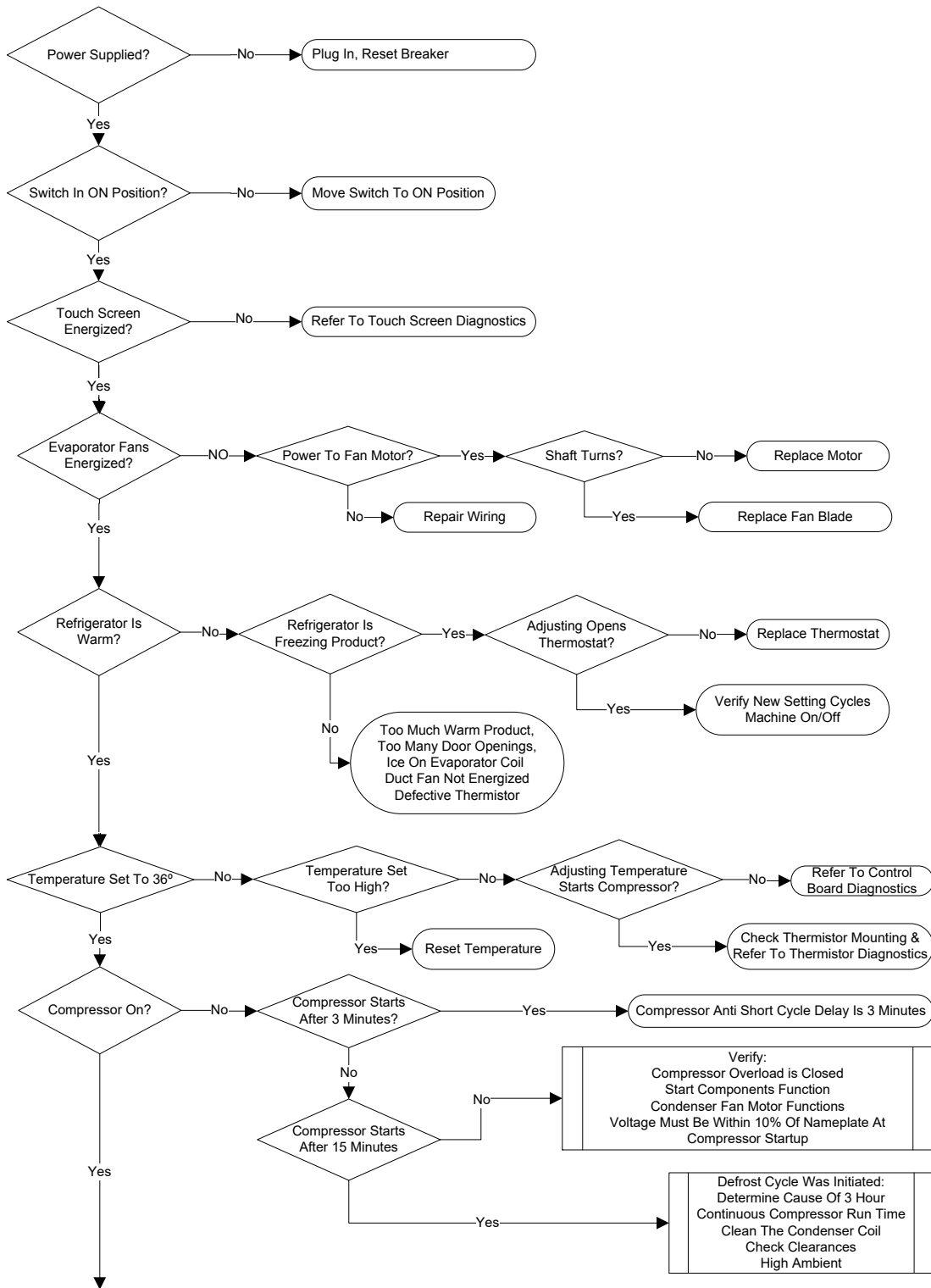

REFRIGERATED CABINET FLOWCHART (CONTINUED)

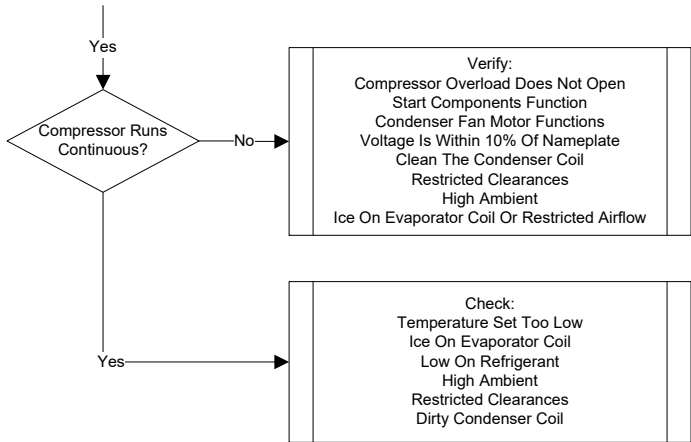

ICE MACHINE ELECTRICAL FLOWCHART

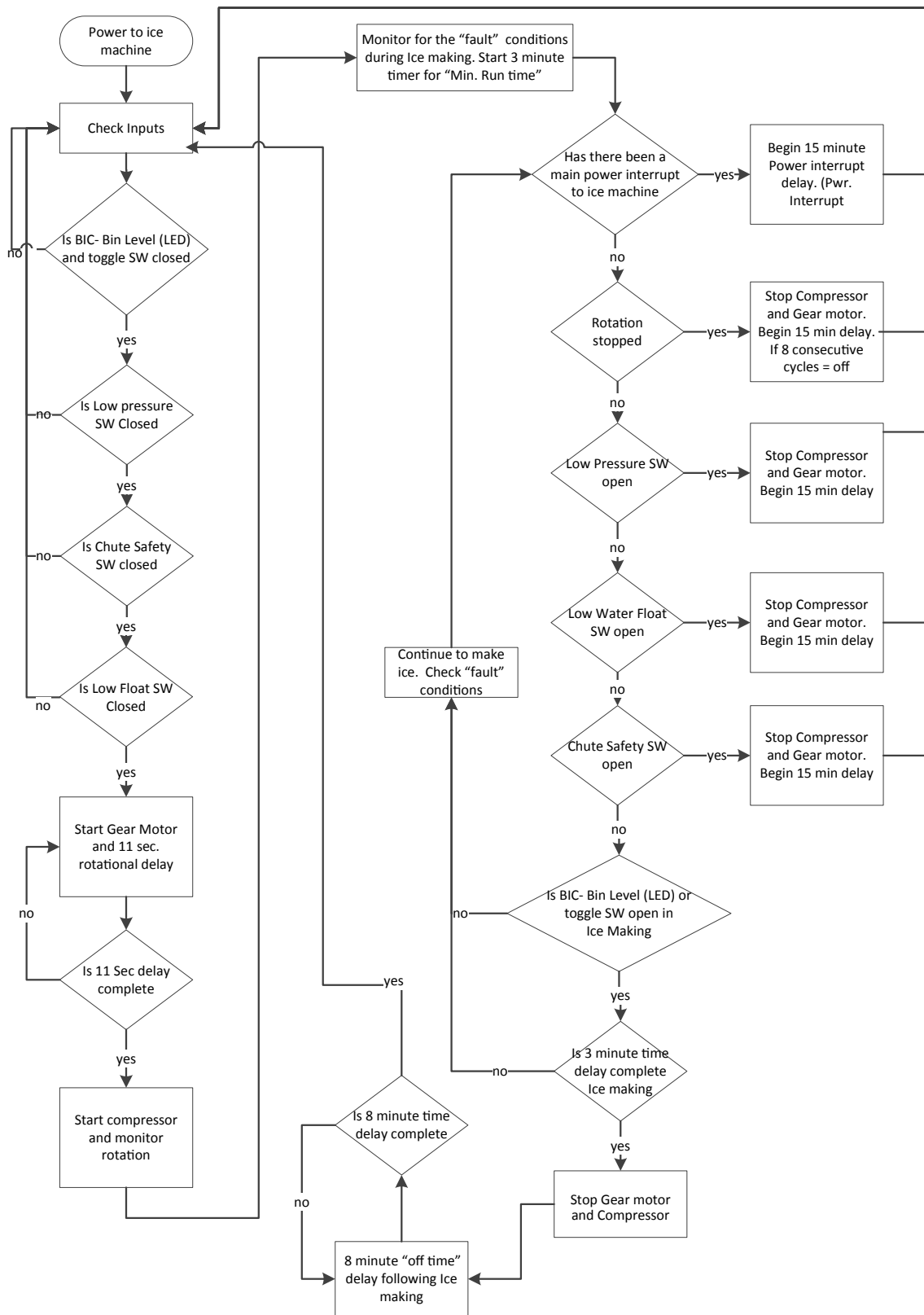

SRB LOGIC - ICE MACHINE START-UP

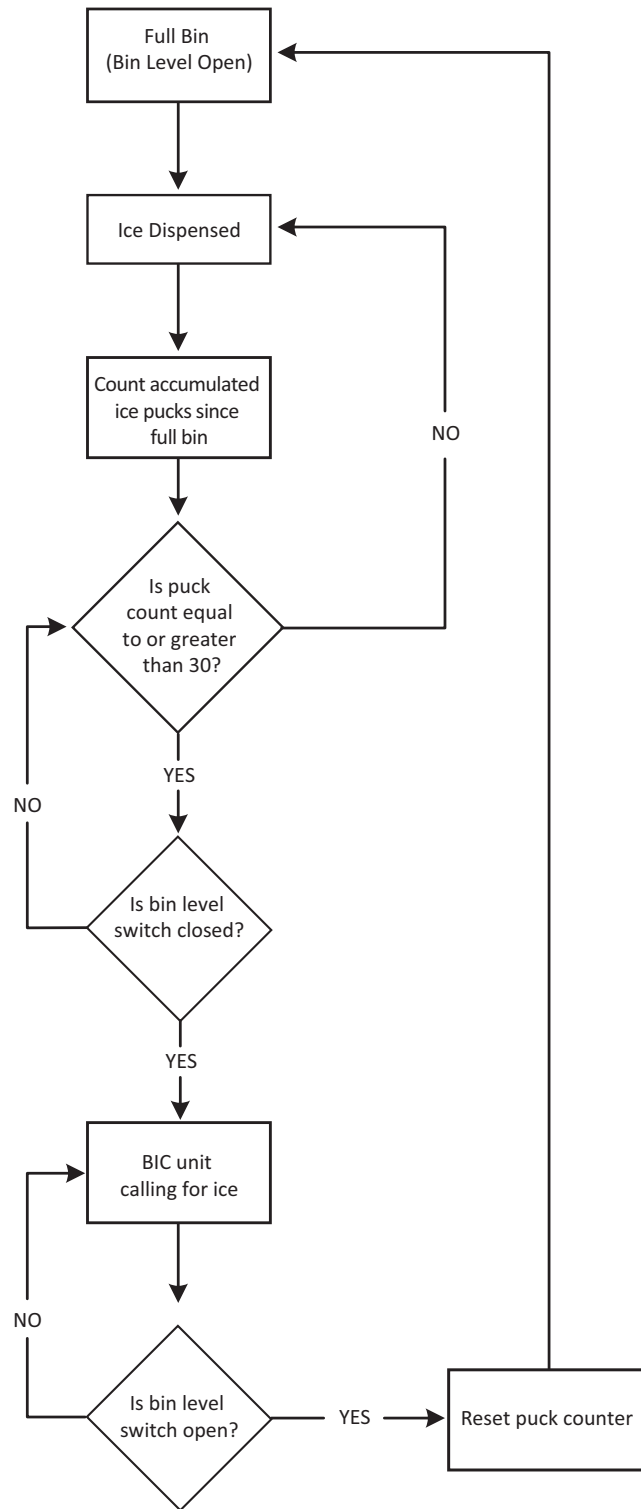

REACH-IN TEMPERATURE OUT OF RANGE

Check Refrigeration System & Door Seal

Temperature in reach-in unit above or below acceptable limits.

Above temperature limit:

- Verify Cabinet temperature is above 5.5°C/42°F.
- Compare temps on UI (User Interface).
- Check duct fan (1) for proper operation.
- Check evaporator fans (3) for proper operation.

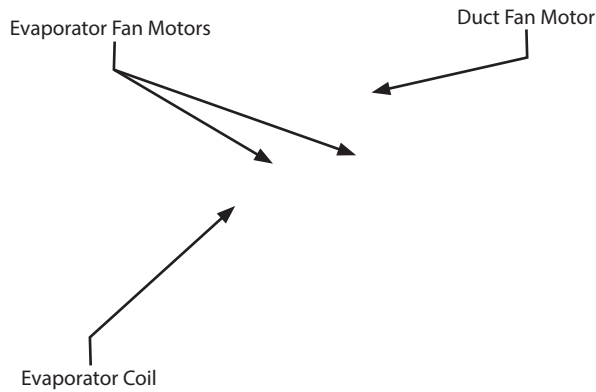

- Touch Service Inputs > Temperatures to view current temperature readings.



- Touch Service Inputs > Refrigeration to view current refrigeration cabinet settings.



- Verify door is closed and door gasket is in place.
- If all above are within Spec's refer to Refrigeration diagnostics. See "Refrigeration System Diagnostics" on page 47.

- Touch Settings > Cabinet to make changes to the default refrigerated cabinet values.

Below temperature limit:

- Compare temps on UI (User Interface).
- Check temperature set point.
- Using the touch screen, go to the Service or Managers Menu on the Main Screen.



Check Thermistor

SPECIFICATIONS

- 5,000 Ohms \pm 2% at 25°C (77°F)
- 16,330 Ohms \pm 2% at 0°C (32°F)

NOTE: These values are only for the white probes that go to the Syrup Storage and Syrup Nozzle probes. The Blue Evaporator Probe has a different resistance range.

CHECK PROCEDURE

NOTE: Use a multimeter to check operation.

1. Reboot machine by moving rocker switch OFF/ON.
2. Inspect for correct wiring.
3. Isolate by disconnecting the wiring connectors on SRB J32 Temp Drive 3 / Cabinet Probe 1.
4. Check continuity across the terminals with an ohm meter.
 - Resistance = Thermistor is good
 - Open (OL) = Replace thermistor

NOTE: These thermistors are identical. Swapping the thermistor connections at the IO board can be used for diagnostics. See "Temperature Thermistor - Nozzle & Cabinet probes only" on page 77.

Check compressor relay on SRB

With power disconnected, check the compressor relay that is mounted on the SRB. The compressor relay is the largest relay on the SRB and has two terminals exposed that can be checked for continuity. The exposed terminals are the Common (C) and the Normally Open (NO). If there is continuity between the terminals with power disconnected to the unit, the relay contacts are defective and the SRB should be replaced.

HIGH PRODUCT TEMPERATURE

Check Duct Cooling Fan

- Product temperature is greater than 42°F.
- Verify the door was not left open or warm product was added.
- Reboot machine by moving toggle switch off/on.
- Verify duct fan is operating.
- Allow machine to run for 15 minutes then prime each product.
- If fault remains check duct temperature with a digital thermometer to determine if refrigeration or thermistor diagnostics need to be performed.

Refrigeration System Diagnostics

REFRIGERATION SYSTEM CHECKLISTS

INSTALLATION/VISUAL INSPECTION CHECKLIST

Inadequate Clearances

- Check all clearances on sides, back and top.

Condenser is dirty

- Clean the condenser

Inadequate Water supply

- Refer to water system checklist

Ice machine is dirty

- Clean ice machine - excessive operational noise will normally be corrected with cleaning. Infrequent cleaning may need an overnight soak with ice machine cleaner to remove all lime/scale deposits.

ANALYZING DISCHARGE PRESSURE OR TEMPERATURE

1. Determine the ice machine operating conditions:
 - Air temperature entering condenser
 - Air temperature around ice machine
 - Water temperature entering water reservoir
2. Refer to 24-Hour Ice Production/Refrigeration Pressure/Temperature Chart on page 85 for ice machine being checked.

Use the operating conditions determined in step 1 to find the published normal discharge pressure/temperature and compare to actual measurements.

3. Measure the actual discharge pressure/temperature.
4. Compare the measurements (step 3) with the published pressure/temperature (step 2).

Measurements will fall within the published range on normally operating ice machines.

Discharge Pressure/Temperature High Checklist

Problem	Cause
Improper installation	Refer to Installation procedures.
Restricted condenser air flow	Dirty air filter High inlet air temperature Condenser discharge air recirculation Dirty condenser fins Defective fan motor Defective fan cycle control
Improper refrigerant charge	Overcharged Non-condensable in system Wrong type of refrigerant
Other	Non-OEM components in system High side refrigerant line/component restricted (before mid-condenser)

Discharge Pressure/Temperature Low Checklist

Problem	Cause
Improper installation	Refer to Installation procedures.
Improper refrigerant charge	Undercharged Wrong type of refrigerant
Other	Low ambient temperature High side refrigerant lines/component restricted (before mid-condenser) Suction pressure is too low and affecting discharge pressure. (Refer to "Suction Pressure/Temperature Low Checklist.") No water or insufficient pressure Starving expansion valve Defective compressor Moisture in refrigeration system Defective fan cycle control

NOTE: Do not limit your diagnosis to only the items listed in the checklists.

ANALYZING SUCTION PRESSURE OR TEMPERATURE

NOTE: Analyze discharge pressure/temperature before analyzing suction pressure/temperature. High or low discharge pressure/temperature may be causing high or low suction pressure/temperature. See "24-Hour Ice Production/ Refrigerant Pressure Charts" on page 85 for charts.

Suction Pressure/Temperature High Checklist

Problem	Cause
Improper installation	Refer to Installation procedures.
Discharge pressure	Discharge pressure/temperature is too high and is affecting suction pressure/temperature. Refer to "Discharge Pressure/Temperature High Checklist."
Improper refrigerant charge	Overcharged Wrong type of refrigerant Non condensible in system
Other	Non-OEM components in system TXV flooding (check bulb mounting and insulation). Defective compressor

Suction Pressure/Temperature Low Checklist

Problem	Cause
Improper installation	Refer to Installation procedures.
Discharge pressure/temperature	Discharge pressure/temperature is too low and is affecting suction pressure/temperature. Refer to "Discharge Pressure/Temperature Low Checklist."
Improper refrigerant charge	Undercharged. Wrong type of refrigerant.
Other	Non-Manitowoc components in system. Restricted/plugged liquid line drier. Restricted/plugged tubing in suction side of refrigeration system. Expansion valve starving. No water or insufficient pressure. Moisture in refrigeration system. Dirty evaporator. Defective fan cycle control.

NOTE: Do not limit your diagnosis to only the items listed in the checklists.

Water System Checklist

A water-related problem often causes the same symptoms as a refrigeration system component malfunction.

Water system problems must be identified and eliminated prior to replacing refrigeration components.

Water area (evaporator) is dirty

- Clean as needed

Water inlet pressure not between 20 and 80 psig (1-5 Bar, 138-552 kPa).

- Install water regulator or increase water pressure

Incoming water temperature is not between 40°F (4°C) and 90°F (32°C)

- If too hot, check the hot water line check valves in other store equipment

Water filtration is plugged (if used)

- Install a new water filter

Water fill valve is stuck open or closed

- Clean/replace as needed

Water is leaking out of the float reservoir overflow tube

- Adjust or replace float

Section 6 Controls

Touch Screens

The main user screen is for the drink making procedure: Drink Selection displays by default at start-up. The Service and Manager's Menu for accessing the machine's settings is hidden and password protected. Inventory, Cleaning, and other Service oriented screens are also available through the password protected area.

MAIN SELECT TO START SCREEN

The Drink Selection screen appears on power-up (except where clean/sanitize limitations have been exceeded, in which case the Cleaning screen appears). See "Control System" on page 65 for Daily, Weekly and Monthly cleaning/sanitation. The Drink Selection screen's primary function is to select a drink to make or to access the Main Menu.



How to Access

The Touch to Start screens display by default unless cleaning is required or drink selection is being made.



NOTE: Touch the Touch to Start icon to proceed to drink choices

Icon Button Descriptions

- **Touch to Start**
Touching this icon begins the drink selection process.
NOTE: Available drink selections may vary depending on the recipe file installed.
- **Password Screen**
To access the hidden password screen touch the bottom left, right then top right corners of the screen in that order. Once the password screen appears press enter to go to the Employee screen or enter the password for the Manager's or Service menu.
- **Cleaning Reminders**
When due, an icon displays the time remaining in days until ZONE 2 (Weekly) and ZONE 3* (Monthly) cleaning is required.
** If equipped with this feature.*

DRINK SELECTION SCREEN

The category screen is the start of the drink making procedure. The Drink Selection screen appears after the Touch to Start icon has been touched. The Drink Selection screen’s primary function is to select a drink category and start the drink making process.

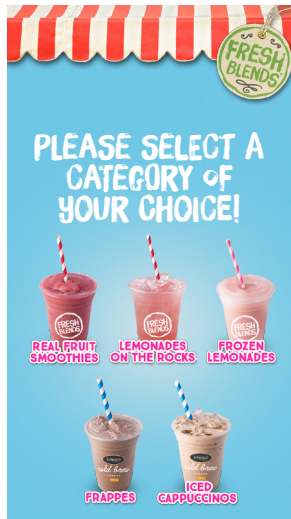

How to Access

The Drink Selection screen displays after touching the Touch to Start icon in the main screen.

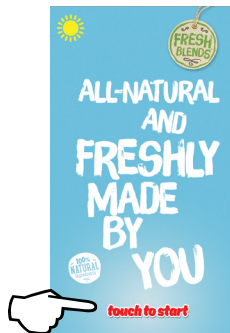

Select a Category to continue to next screen.

Icon Button Descriptions

- Drink Categories**

The main product categories are displayed left to right on the Drink Selection screen. Touching a category will display the drink flavor options available for the category.

NOTE: Available drink selections may vary depending on the recipe file installed.
- Cleaning Reminders**

When due, an icon displays the time remaining in days until ZONE 2 (Weekly) and ZONE 3* (Monthly) cleaning is required.

** If equipped with this feature.*

FLAVOR SELECTION SCREEN

The Flavor Selection screen appears after a Drink Selection has been made. Flavor options will vary depending on what recipes are configured on the unit. This screen's primary function is to select a drink flavor.



How to Access

The Flavor Selection screen displays after a drink selection has been made from the Drink Selection screen.



Select Flavor to continue to next screen.

Icon Button Descriptions

- **Drink Flavor Buttons**
Flavor choices for the drink type that was selected.
NOTE: Available flavor selections may vary depending on the recipe file installed.
- **Back Button**
Navigates back one screen.
- **Cleaning Reminders**
When due, an icon displays the time remaining in days until ZONE 2 (Weekly) and ZONE 3* (Monthly) cleaning is required.

** If equipped with this feature.*

CONFIRMATION SCREEN

The Confirmation screen appears after a drink flavor has been chosen from the Flavor Selection screen. This screen's primary function is to verify the customer's drink choice. Optional Add-Ins are also performed through this screen if the drink requires them.



How to Access

The Flavor Selection screen displays after a drink selection has been made from the Drink Selection screen.



The screen will display all selected drink information and prompt customer to confirm.

- **Back Button**
Navigates back one screen.
- **Cleaning Reminders**
Displays the time remaining in days until ZONE 2 (Weekly) and ZONE 3* (Monthly) cleaning is required.
** If equipped with this feature.*

Select "Confirm Selection" to continue to next screen

SIZE SCREEN

The Size screen appears after a drink flavor has been confirmed from the Confirmation screen. This screen's primary function is to select size and make a drink.



Icon Button Descriptions

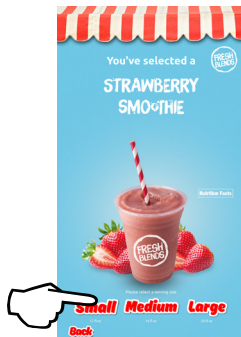

- **Drink Size Buttons**
Press a drink size (SMALL, MEDIUM, or LARGE) to start the drink making process.
- **Back Button**
Navigates back one screen.

NOTE: Make sure the correct cup is in place before pressing the drink size button, once one is selected the unit will start dispensing ice and product, the screen will display "DISPENSING". Other entertainment, animation, games or advertisements may also display on this screen during this time.

Dispensing & Blending Screens



- The dispensing screen displays as ice and product dispense into the cup. An on screen percentage will display the amount until dispense is finished.
NOTE: Once dispense is complete the cup will automatically move into the blend chamber.
- Once the drink has automatically moved into the blend chamber, the blend screen will then display. An on screen percentage will display the amount until blending is finished.
NOTE: The screen will display "Blending". Other entertainment, animation, games or advertisements may also display on this screen during this time.
- When the blending process is complete the screen will prompt the customer it is finished and the drink will automatically move back into the dispense area.

Procedure to Make a Drink

NOTE: Ice must be present in the ice hopper, product must be connected and primed to produce a drink.

1. The Drink Selection screen displays after touching Touch to Start.



NOTE: Drink choices will vary depending on loaded recipe file

2. The Flavor Selection screen displays after a drink selection has been made from the Drink Selection screen.



3. Select Flavor to continue to next screen



4. Select "Confirm Selection" to continue to next screen

5. The Size screen appears after a drink flavor has been confirmed from the Confirmation screen.



NOTE: Make sure the correct cup is in place before pressing the drink size button.

6. Select the size to start dispensing ice and product, the screen will display "DISPENSING".



7. Once the drink has automatically moved into the blend chamber, the blend screen will then display. An on screen timer will count down the time remaining until blending is finished.

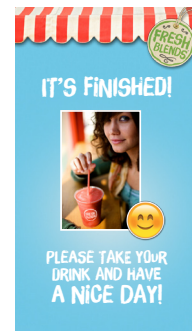
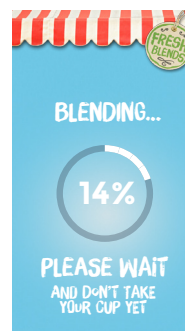

8. The screen will display "Blending". Other entertainment, animation, games or advertisements may also display on this screen during this time.
9. When the blending process is complete the screen will prompt the customer it is done and the drink will automatically move back into the dispense area.

EMPLOYEE, MANAGERS, & SERVICE MENU SCREENS

Accessed through the main start screen, this screen's primary function is to provide access to cleaning, bag change procedures and other functions specific to the user accessing them. Only certain functions can be performed on the unit by an employee, manager or service technician. It takes a special touch sequence to access these screens and is password protected.



Employee Menu Screen Items

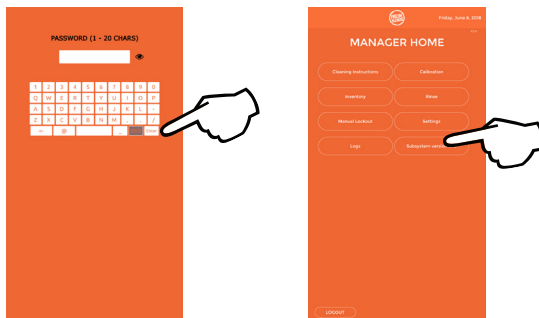

- Leave the password field blank and touch the ENTER button to enter the Employee menu.
- For managers, type the Managers password then touch ENTER.
- For service technicians, type the Service password then touch ENTER.

PRODUCT INVENTORY SCREEN

This screen's primary function is to provide visual product inventory information for the user. The Product Inventory screen is normally accessed through the Main Menu.

The inventory screen visually displays levels for all flavors. Underneath each flavor is the time remaining until the flavor expires in days. NOZZLE and CABINET temperatures are also on the inventory screen. When a flavor is touched on the screen, the instructions to replace a product bag will begin. (See "Procedure to Install a Product Bag" on page 58)



How to Access

This is done through the Employee, Managers, or Service Screen options.

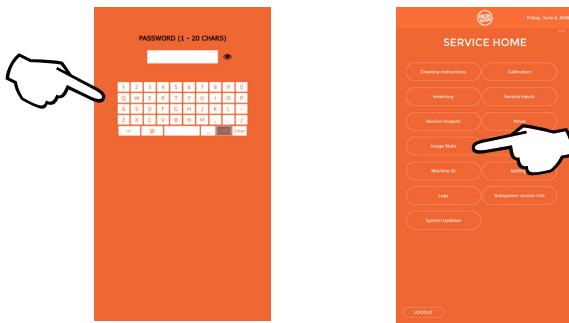

- Enter the Employee, Managers, or Service menu.

ASSIGNING FLAVORS

Accessed through the main start screen, this screen's primary function is to provide access to all other procedures and adjustments that can be performed by a manager on the unit. It takes a special touch sequence to access and is password protected.

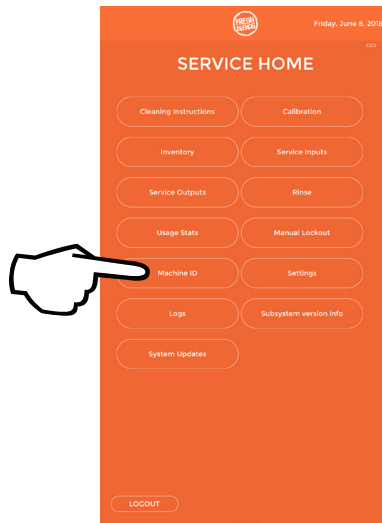

Enter Password

1. This is done through the Employee, Managers, or Service Screen options.

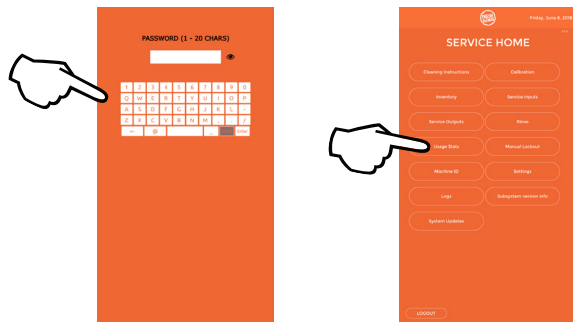

3. Follow the on-screen instructions and prime the product.

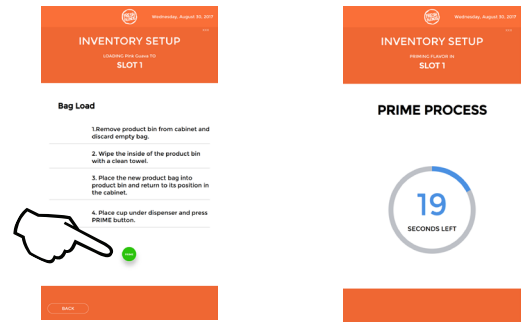

NOTE: In order to dispense product a product bag must be loaded (See "Procedure to Install a Product Bag" on page 58) and calibrated (See "Product, Ice, & Water Calibration" on page 59).

- Enter the Employee, Managers, or Service menu.
2. Choose a slot and then choose a flavor/product type that is loaded into the bin.

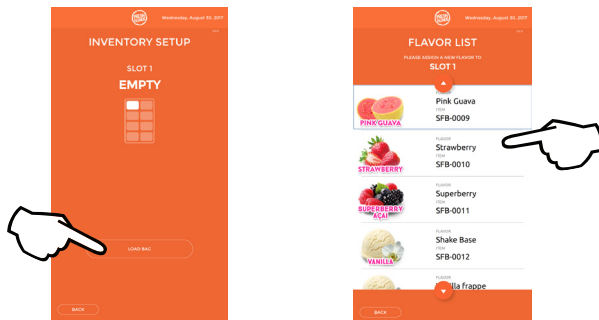

Procedure to Install a Product Bag

This is done through the Employee, Managers, or Service Screen options.

1. Enter the Employee, Managers, or Service menu. See "Employee, Managers, & Service Menu Screens" on page 55

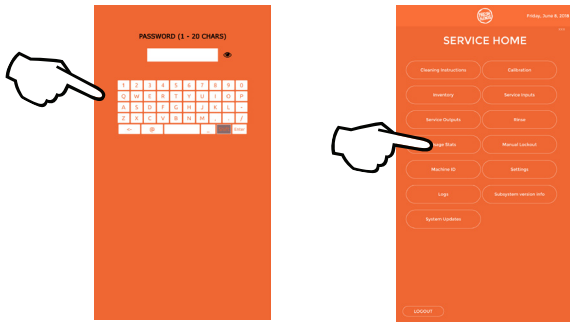

2. Select the INVENTORY button.
3. Choose the corresponding slot on the screen where the bag was just loaded. If the slot was empty the circle icon representing the slot will read LOAD BAG. If there is already product in the slot it will display the flavor name.
 - If loading a new bag in an empty slot the screen will display EMPTY. Press the LOAD BAG button.
 - If reloading an existing flavor the screen will display the flavor and options for BAG REMOVAL, BAG RELOAD, or PRIME. Choose to RELOAD if loading the same flavor, or REMOVAL if loading a different flavor.

NOTE: When loading a new bag you will need to assign a flavor following the instructions on the screen and scrolling to the flavor being loaded.

NOTE: When performing a BAG REMOVAL the screen will instruct you on removal and you will then be taken back to the setup screen to load a new bag.

4. After assigning a flavor or pressing BAG RELOAD the screen will instruct on how to load the bag in the lower refrigeration cabinet.
5. Remove product bin from the cabinet, discard existing product bag if there is one.
6. Wipe down and clean the product bin before installing the new product bag into the bin.

NOTE: When installing the new product bag make sure the product pump is facing the correct way with the product elbow pointing towards the back of the bin and properly snaps into the bin.

7. Slide the loaded product bin into its slot in the lower refrigeration cabinet and latch into place.

NOTE: Do not force the latch over the pump, if the latch does not snap into place adjust the pump until it properly seats on the sanitation fitting and latches easily.

8. Close the refrigeration door and place a cup into the dispense area.
9. Press the prime button to prime the bag.

PRODUCT, ICE, & WATER CALIBRATION

Important

Allow cabinet to reach operating temperature 34°F – 38°F (1°C – 3°C) before calibrating. Calibration will be inaccurate if performed above operating temperatures.

Pre-calibration Checklist

- If calibrating ice verify bin is at least half full.
- If calibrating ice, go to Service> Outputs> Ice Motor Menu and manually dispense 2 large cups of ice prior to calibrating.
- Check for empty product bags in the cabinet and replace if necessary.
- Ensure that each flavor has a bag more than 1/3 full.
- Check bag to ensure the spout is securely locked in position and the spout side of bag is facing down.
- Ensure product flavors to be calibrated have been refrigerated for 24 hours in a 34°F/1°C – 40°F/4°C environment and the product cabinet is at operating temperature 32°F/0°C – 34°F/1°C.
- Check Zone 2 cleaning was completed over 1 hour ago.
- Check that Machine has been turned on for at least 1 hour – Do not proceed with this check during peak time - Dispense 2 large cups of ice.

Gather the following supplies

Digital Scale Set to ounces	
Empty & Clean Cups	

1. Enter the Employee, Managers, or Service Screen options.

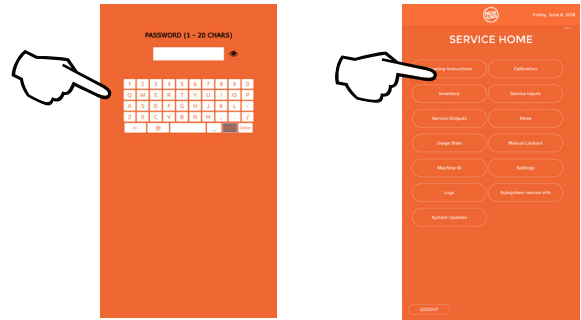

2. Select the CALIBRATION button.
3. Select what is going to be calibrated, ICE, WATER or FLAVOR.

NOTE: If calibrating ice or water these will only dispense 1 time, flavors will take an average of 3 -5 dispenses.

4. Follow the on screen instructions and place a cup in the dispense area.
5. Press the button to dispense when ready.
6. When dispense has finished weigh the cup and enter the weight of the dispense into the screen, then press enter.
7. Repeat this 3 - 5 times as prompted by the screen.
8. Once completed you will be returned to the main calibration screen.
9. The ice, water, or flavor is now calibrated, go back to calibrate more flavors or press back and logout to go back to the drink making screen.

SHUTTLE CALIBRATION

This is done through the Employee, Managers, or Service Screen options.

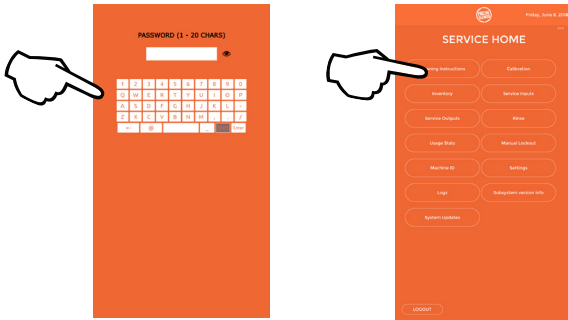

- Enter the Employee, Managers, or Service menu.
 1. Select the CALIBRATION button.
 2. Select Shuttle Calibration.

CLEANING INSTRUCTIONS SCREEN

The Cleaning screen appears after selected from the Main Menu or when prompted to perform routine cleaning. This screen's primary function is to perform routine cleaning and sanitation of the machine.

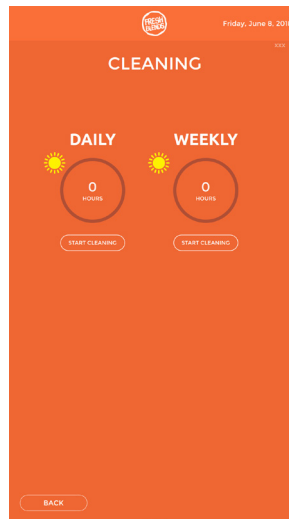

How to Access

This is done through the Employee, Managers, or Service Screen options.

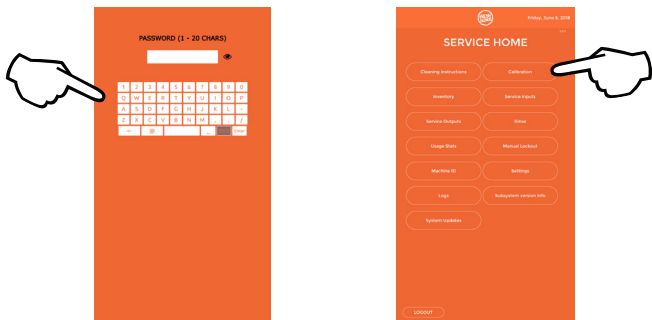

- Enter the Employee, Managers, or Service menu.

Important

Once the time limit has been exceeded the machine will no longer make a drink until cleaning has been completed.

See "General Maintenance" on page 25 for all daily and weekly cleaning instructions.

Other Operations

LOADING NEW MENU RECIPES

How to Access

This is done through the Managers or Service Screen options only.

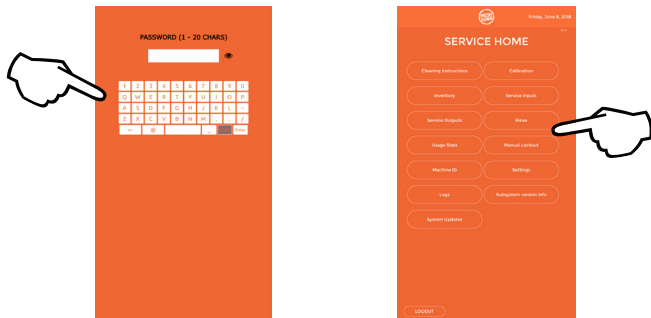

1. Enter the Managers or Service menu.
2. Select the SYSTEM UPDATES button and choose MENU.
3. Press CHECK FOR UPDATE if the button appears.
4. If a new menu is available or has been sent to the machine it will display here as available for download.
5. Press UPDATE to begin the download and let the unit proceed to download then apply the update.
6. The screen should then reboot on its own to complete the update.

Once the screen comes back up and the drink making screen appears the new menu will be available. Reloading or loading of new product may be necessary.

MANUAL LOCKOUT

How to Access

This is done through the Managers or Service Screen options only.

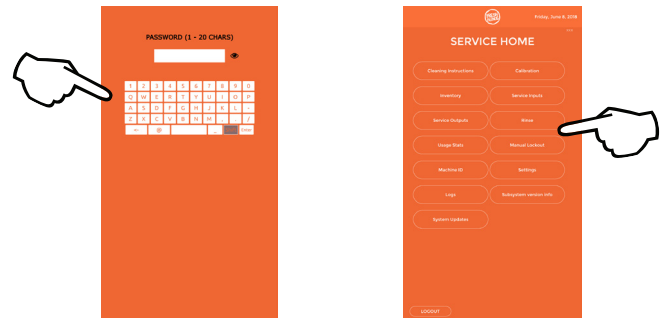

1. Enter the Managers or Service menu.
2. Select the MANUAL LOCKOUT button.
3. Through this screens toggle you can lock the unit, preventing users from making drinks.

NOTE: This screen may be helpful if it needs to be down for maintenance or other reasons.

USAGE STATS

How to Access

This is done through the Managers or Service Screen options only.



1. Enter the Managers or Service menu.
2. Select the USAGE STATS button.
3. This screen displays usage stats for the unit.

SERVICE INPUTS

How to Access

This is done through the Managers or Service Screen options only.

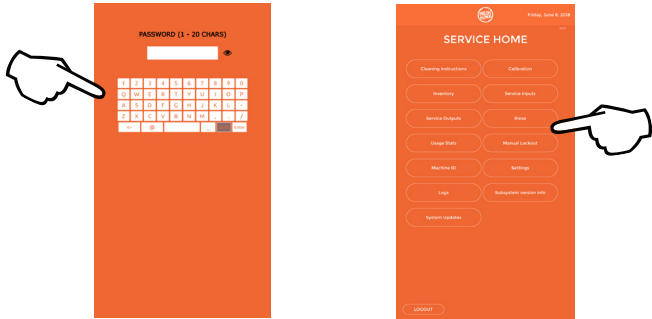

1. Enter the Managers or Service menu.
2. Select the SERVICE INPUTS button.
3. This screen displays a variety of different readings like temperatures and current states of the machine.

SERVICE OUTPUTS

How to Access

This is done through the Managers or Service Screen options only.

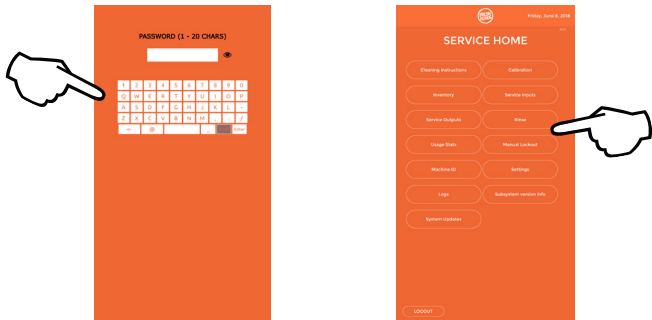

1. Enter the Managers or Service menu.
2. Select the MANUAL LOCKOUT button.
3. This screen gives access to all outputs on the unit.

NOTE: This screen will allow the user to manually operate individual solenoids and other output functions on the machine. Primary use of this screen is troubleshooting and diagnostics to be used by a service technician.

MACHINE ID

How to Access

This is done through the Managers or Service Screen options only.

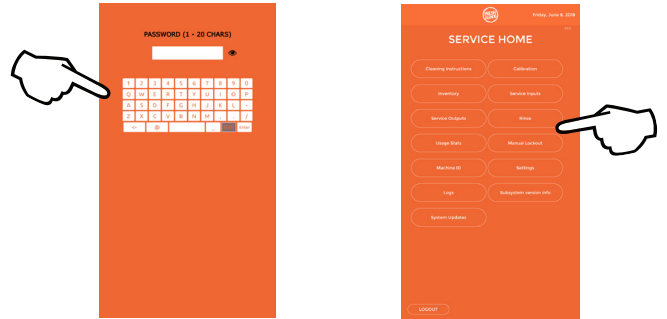

1. Enter the Managers or Service menu.
2. Select the MACHINE ID button.

SETTINGS

How to Access

This is done through the Managers or Service Screen options only.

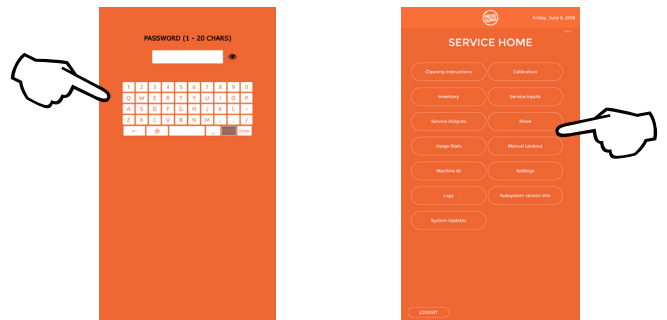

1. Enter the Managers or Service menu.
2. Select the SETTINGS button.

LOGS

How to Access

This is done through the Managers or Service Screen options only.

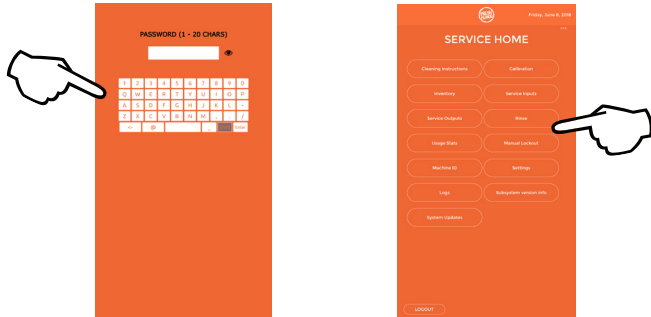

1. Enter the Managers or Service menu.
2. Select the LOGS button.

SUBSYSTEM VERSION INFO

How to Access

This is done through the Managers or Service Screen options only. This screen will display what software/ firmware versions are currently loaded on the machine.

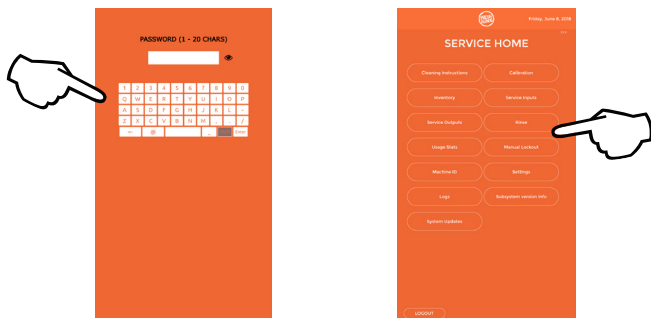

1. Enter the Managers or Service menu.
2. Select the SUBSYSTEM VERSION INFO button.

Section 7

Component Check Procedures

Control System

ON/OFF ROCKER SWITCH

Location

The ON/OFF switch is located on the left side of the unit when viewing from the front.

Function

Supplies power to the Blender components. Turns unit ON and OFF.

Specification

This is a rocker switch with a double pole, double throw switch.

Check Procedure

To check the switch, unplug the power supply to the equipment.

1. Check for loose or broken wires at that terminal.
2. Remove the wires (marked #14) and with your ohm meter check continuity between (2) two terminals in the ON position.

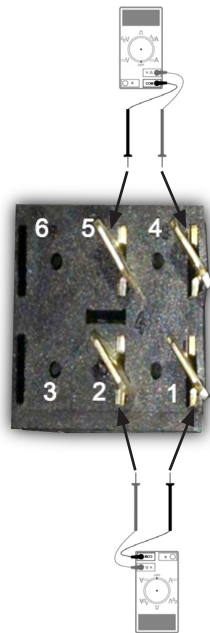
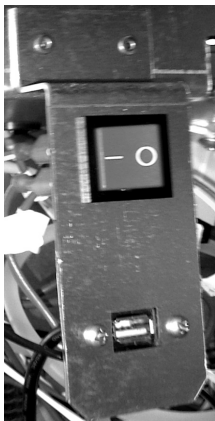

3. There should be continuity.
4. If no continuity is read, replace the switch.
5. Press the switch to the OFF position (O).
6. Check continuity between the (2) two terminals, there should be no continuity between the terminals.
7. If continuity is read, replace the switch.

POWER RELAY

Location

Located behind the left-hand side panel.

Function

Removes full load amperage of components and motors from ON/OFF rocker switch.

Specification

Double Pole Single Throw (DPST), 220 VAC coil, average coil resistance 21 KOhms, Contact rating - 30A @ 120 VAC. When energized, contacts close and allow power to flow to SRB board (J9 & J10), Power Supply (CN1), and Evaporator Fans.

Check Procedure

There is a small black manual push button on the relay body to allow testing of the contacts with the unit de-energized. Disconnect the wiring to the contacts and check resistance while pressing the test button. The resistance across the contacts should be less than 1.0 ohms.

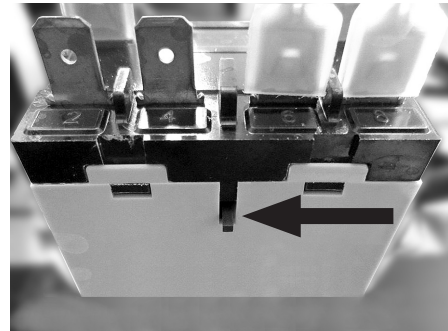

- Manual Test Button, Press to close contacts.

If the relay is energized and contacts are closed the button will be pulled in, flush with the body of the relay.

Power Relay Coil Test Procedure

1. Check the coil using an ohm meter, the coil should have a nominal resistance reading. If no reading the coil is open and the Power Relay should be replaced.
2. With the ON/OFF rocker switch in the ON position, check for line voltage at relay coil.
 - Line voltage present - Contacts should be closed, if not replace the relay.
 - No line voltage present - Refer to ON/OFF rocker switch check procedure.

FAN CYCLE CONTROL

FUNCTION

Cycles the fan motor on and off to maintain proper operating discharge pressure.

The fan cycle control closes on an increase, and opens on a decrease in discharge pressure.

SPECIFICATIONS

Specifications		
Refrigerant Type	Cut-In (Close)	Cut-Out (Open)
R404A	250 ±5 (1723 kPa ±.34) (17.23 bar ±.34)	200 ±5 (1517 kPa ±.34) (15.17 bar ±.34)
R290	250 ±5 (1723 kPa ±.34) (17.23 bar ±.34)	200 ±5 (1517 kPa ±.34) (15.17 bar ±.34)

CHECK PROCEDURE

1. Verify fan motor windings are not open or grounded, and fan spins freely.
2. Connect manifold gauge set to ice machine.
3. Hook voltmeter in parallel across the fan cycle control, leaving wires attached.
4. Refer to chart below.

FCC Setpoint:	Reading Should Be:	Fan Should Be:
Above Cut-In	0 Volts	Running
Below Cut-Out	Line Voltage	Off

ICE CHUTE SWITCH

Function

When the storage bin is full, the ice contacts the paddle and holds the switch open. After the switch is open for 5 continuous seconds, the ice machine shuts off and a 15 minute delay period starts. The ice machine remains off until enough ice is removed from the storage bin to allow the switch to close. The ice machine will then restart, provided the 15-minute delay has expired.

Specifications

Normally closed, 5 amps 125/250 VOLTS

Symptoms

Ice Chute Switch Fails Open

- The ice machine will not start an ice making cycle and the control board bin switch light remains on.

Bin Switch Fails Closed

- The ice machine continues to run after ice contacts the ice damper and the control board light remains off.

DIAGNOSTICS

1. Open and close the ice chute switch repeatedly while observing the control board lights.
 - A. Ice chute switch cycles open/closed and control board light energizes/de-energizes - Ice chute switch is operating normally
 - B. Ice chute switch remains closed and the control board light remains off. Disconnect the ice chute switch wire from the control board (Bin Level connector). If the light energizes replace the ice chute switch; if the light remains off replace the control board.
 - C. Ice chute switch remains open and control board light remains on. Disconnect the ice chute switch wire from the control board (Bin Level connector) and jumper control board terminals. If the light de-energizes replace the ice chute switch; if the light remains on replace the control board.

BLENDER CONTROL BOARD

Location

Each blend chamber has a dedicated Blender Control Board. The Blend Chamber Assembly needs to be separated from the frame in order to access the blender control board.

Function

The Blender Control Board provides control of the blender position, up/down movement of the linear slide, and on/off motor operation. The Blender Control Board is software-driven and retains firmware which can be updated via the USB port, near the power switch on the left side of the unit.

Specifications

The Blender Control Board receives 230 VAC line voltage and 24 VDC low voltage. The blender board executes the blend profile of the customer's recipe when a drink is selected. The board will distribute voltage to the blender motor, linear slide, or the rinse water solenoid as instructed according to the current firmware and instruction from the UI. Instruction from the UI is transmitted via Modbus communication cable connected at J4. The blender also receives input from the blender door reed switch and the blender home position switch.

Check Procedure

The Blender Control Board function can be tested via the "Outputs" in the UI service screen. (Managers Menu > Service > OUTPUTS). Operate the blender blade to verify blade operation and/or the blender slide to verify linear slide operation.

To test the motor blade it's best to place a cup of water in the blend chamber to be tested, activate the blender slide on the side to be tested, and then activate the blender blade. This will allow for a better visual of the blade turning.

NOTE: The blender blade will only operate for 3 seconds at half voltage in this test function.

The blender door must be fully closed to allow blender operation. The door position can be confirmed using the "Inputs" screen - Managers Menu > Service > INPUTS. This will verify the software is correctly reading the door position. Open the perspective door (left / right) and the Input should report the current condition, "open" or "closed".

Blender Board connections:

- J5 (N) / J6 (L1) - 230 VAC
- J2 (N) / J7 (L1) - 230 VAC (Present with relay closed)
- J12 - Rinse Water Solenoid Valve, 24 VDC
- J4 - Modbus communication
- J9 - Reed Switch / 3 wire
- Brown to White - NC
- Green to White - NO
- J13 - Home position switch - NO
- J10 - Linear Slide Stepper Motor
- J1 - 24 VDC input (T1 +24 VDC / T2 -24 VDC)
- Onboard fuse - protects blender motor output circuit, 2.5 amp.
- DIP switch settings - All in the "OFF" position identifies the left side board, #1 switch in the "ON" position and #2, 3 & 4 in the "OFF" position identifies the right side board.
- Has one LED:
 - Constant when first powered on.
 - Blinks when linear slide reaches home.
 - Heartbeat after homing is accomplished.

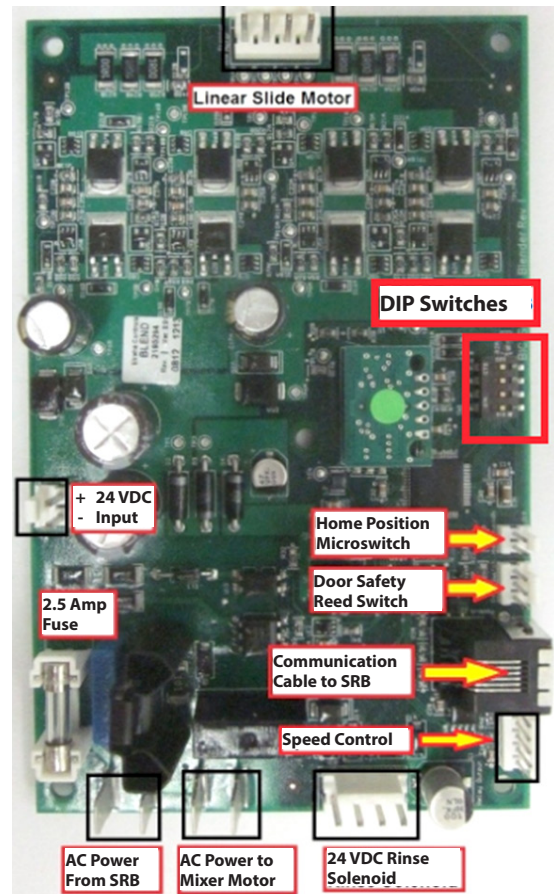

Beverage Components

BLENDER STEP MOTOR

Function

Raises and lowers the blender blade to provide consistent mixing of ingredients.

Specification

5 VDC from Blender Board

Check Procedure

1. Disconnect the connector (MTA4), terminals TP12B, TP13B, TP14A and TP13A on the top of Blender Board. The Blender Board is located on the left side of the machine near the the Blender Assembly. See "Blender Control Board" on page 67.
2. Check for 5 VDC across XXX.
 - Open (OL) = Replace motor.
 - Resistance = Motor windings are good.
3. Check rotor for excessive play or binding.
4. Test home position switch.
5. Test door switch(es).
6. Replace Blender Board.

BLENDER MOTOR

Function

Mixes ingredients to maintain a consistent product.

Specification

120V/60Hz or 220V/50Hz

Check Procedure

Use a voltmeter/ohm meter to check motor operation.

1. Disconnect the Blue and White wires from the Blender motors. Blender Board is located on the back of the Blender Assembly.
 - Check resistance across the blender motor leads.



- Open (OL) = Replace motor.
 - Resistance = 95 ohms motor is good.
2. Check rotor for excessive play or binding.
 3. Test capacitor.
 4. Test home position switch.
 5. Verify relay is closed/powered - if not test door switches.
 6. Replace Blender Board.

HOME POSITION SWITCH**Function**

Prevents blender motor operation if the step motor does not return to the home (up) position.

Specification

SPST Normally Open Switch

Location

On Blender Assembly / Linear Slide bracket. One switch on left side bracket and one switch on the right side bracket.

Check Procedure

Use a voltmeter/ohm meter to check switch operation.

1. Inspect the switch for correct wiring. On Blender Board at J13 Terminal, 1 = Blue Terminal 2 = Brown.
2. Isolate the switch by disconnecting the wiring connectors. On Blender Board at J13 Terminal, 1 = Blue Terminal 2 = Brown.
3. Check continuity across the switch terminals in the open and closed position. Replace the switch if continuity readings do not match both switch settings. On Blender Board at J13 Terminal, 1 = Blue Terminal 2 = Brown.
 - Open (OL) = Replace motor.
 - Resistance (0) = Motor is good.

DOOR SWITCHES**Function**

Prevents blender motor operation if the door/switch is not closed.

Location

Magnetic switch is located on top of the Blend Chamber / Linear Slide Bracket access from the back side. The relay switch is located on each Blender Assembly bracket.

Specification

One (1) Magnetically operated SPST normally open switch per Blender per side. One (1) Relay switch per blender per side.

Check Procedure

Use a voltmeter/ohm meter to check switch operation.

1. Inspect the switch for correct wiring.
2. Isolate the switch by disconnecting the wiring connectors.
3. Check continuity across the switch terminals in the open and closed position.

Remove = (Replace the switch if continuity readings do not match both switch settings.)

- Open (OL) = Replace motor.
- Resistance (0) = Switch is good.

ICE CHUTE SWITCH

Function

When the storage bin is full, the ice contacts the paddle and holds the switch open. After the switch is open for 5 continuous seconds, the ice machine shuts off and a 15 minute delay period starts. The ice machine remains off until enough ice is removed from the storage bin to allow the switch to close. The ice machine will then restart, provided the 15-minute delay has expired.

Specifications

Normally closed, 5 amps 125/250 VOLTS

Symptoms

Ice Chute Switch Fails Open

- The ice machine will not start an ice making cycle and the control board bin switch light remains on.

Bin Switch Fails Closed

- The ice machine continues to run after ice contacts the ice damper and the control board light remains off.

DIAGNOSTICS

1. Open and close the ice chute switch repeatedly while observing the control board lights.
 - A. Ice chute switch cycles open/closed and control board light energizes/de-energizes - Ice chute switch is operating normally
 - B. Ice chute switch remains closed and the control board light remains off. Disconnect the ice chute switch wire from the control board (Bin Level connector). If the light energizes replace the ice chute switch; if the light remains off replace the control board.
 - C. Ice chute switch remains open and control board light remains on. Disconnect the ice chute switch wire from the control board (Bin Level connector) and jumper control board terminals. If the light de-energizes replace the ice chute switch; if the light remains on replace the control board.

LOW WATER FLOAT SWITCH

Function

Stops the ice machine when the water level drops below an acceptable level.

Specifications

The low water float switch is a magnetically operated reed switch. The magnet is attached to the float.

- When water contacts and raises the float, the switch is electrically closed and the LOW LVL FLT LED will be off.
- When the water level drops the switch is electrically open and the LOW LVL FLT LED will be on.
- When the water level drops below a safe level in the freeze cycle the SAFETY 2 LED is energized and the ice machine stops.

Symptoms

Float Switch Fails Open

- The ice machine will not start an ice making cycle.

Float Switch Fails Closed

- The ice machine continues to run after a loss of water.

Diagnostics

1. Verify float is in place and moves freely.
2. Open and close the float switch repeatedly while observing the control board lights.
 - A. Float switch cycles open/closed and control board light energizes/de-energizes - Float switch is operating normally
 - B. Float switch remains closed and control board light remains on - Go to step 3
 - C. Float switch remains open and control board light remains off - Go to step 4
3. Disconnect float switch wire from control board and observe the control board light.
 - A. Control board LOW LVL FLT LED is off - Replace switch.
 - B. Control board LOW LVL FLT LED remains On - Proceed to step 4.
4. Disconnect bin switch wire from control board (Bin Level connector) and jumper control board bin switch pins and observe the control board light.
 - A. The control board light energizes - Replace bin switch
 - B. The control board light remains off - Verify jumper is making proper pin contact - Replace control board

LOW PRESSURE CONTROL

Function

Energizes and de-energizes the contactor coil when suction pressure rises above or falls below set-point.

The LPCO control is closed at pressures above setpoint and opens at pressures below set-point.

SPECIFICATIONS

Specifications	
Cut-Out	Cut-In
7 psig ±3	22 psig ±3

Check Procedure

1. Install gauge set and restart the ice machine and initiate a start sequence. Watch the refrigerant pressures when the compressor starts.
- LPCO opens above cut-out set-point - Replace the LPCO
- LPCO will not open below cut-out set-point - Replace the LPCO.
- Refrigerant pressure drops below cut-out - Locate the root cause - Low on refrigerant, moisture in system, txv defective, etc.

HIGH PRESSURE CUTOUT (HPCO) CONTROL

Function

Protects the compressor by interrupting the control signal to the control board. Excessive high side pressure operates the HPCO. The HPCO control is normally closed, and opens on a rise in discharge pressure.

Location

Above the ice compressor.

Specification

Refrigerant Type	Cut-Out	Cut-In
R404A	2413 kPa ±24.13 bar ±.69	1723 kPa 17.23 bar ±.69
R290	350 psig ±10	250 psig ±10
The HPCO automatically resets when the pressure drops below the cut-in		

Check Procedure

1. Verify the filter and condenser are clean.
2. With power off, isolate by disconnecting the wiring connectors.
3. Check continuity across the terminals with an ohm meter.
 - Low resistance = Continuity is good.
 - Open (OL) = Replace HPCO.
4. Replace wires on HPCO terminals and also connect volt meter across the HPCO terminals.
5. Install a high side gauge and initiate a start sequence.
6. Watch the refrigerant pressures when the compressor starts.
 - HPCO opens below cut-out set-point - Replace the HPCO
 - HPCO opens above cut-out set-point - Locate the root cause - Fan motor defective, dirty condenser, refrigeration system issue, etc.

GEAR MOTOR ROTATION SENSOR

Function

The rotation sensor monitors evaporator gear motor speed. If the gear motor speed drops below 8 pulses per minute or exceeds 35 pulses per minute the rotation sensor signals the control board to stop the gear motor and compressor.

Specifications

The sensor monitors gear motor rotation and includes a time delay and alarm condition.

- At the initial start-up there is a 10 second delay and the rotational sensor light flashes yellow to indicate a time delay period.
- The rotation sensor delays sensing for 20 seconds to allow the gear motor speed to stabilize.
- If the gear motor speed is outside the range the red sensor light flashes for 10 seconds,. After 10 seconds the sensor light switches to yellow and monitors motor speed. If this cycle repeats 8 consecutive times the sensor goes into an alarm condition - The red sensor light is on and the ice machine stops until reset.

NOTE: The SAFETY 2 LED on the control board is also energized.

Light	Definition
Yellow Blinking	Time Delay Period
Yellow Solid	Normal Operation
Red Blinking	Fault Time Delay Period
Red Solid	Lockout - 8 Consecutive Faults Remove/Restore Power To Reset

FAN CYCLE CONTROL

Function

Cycles the fan motor on and off to maintain proper operating discharge pressure.

The fan cycle control closes on an increase, and opens on a decrease in discharge pressure.

Specifications

Specifications		
Refrigerant Type	Cut-In (Close)	Cut-Out (Open)
R404A	250 ±5 (1723 kPa ±.34) (17.23 bar ±.34)	200 ±5 (1517 kPa ±.34) (15.17 bar ±.34)
R290	250 ±5 (1723 kPa ±.34) (17.23 bar ±.34)	200 ±5 (1517 kPa ±.34) (15.17 bar ±.34)

Check Procedure

1. Verify fan motor windings are not open or grounded, and fan spins freely.
2. Connect manifold gauge set to ice machine.
3. Hook voltmeter in parallel across the fan cycle control, leaving wires attached.
4. Refer to chart below.

FCC Setpoint:	Reading Should Be:	Fan Should Be:
Above Cut-In	0 Volts	Running
Below Cut-Out	Line Voltage	Off

GEAR MOTOR ASSEMBLY**Function**

Turns the auger in the evaporator assembly.

Specifications

115-120V 60Hz or 230V 50Hz 2.5 RPM .13 HP

Check ProcedureMOTOR WILL NOT RUN.

1. Verify line voltage is present at the gear motor electrical connector (wires 80 & 81).
2. Disconnect electrical connector and check for resistance between line 1 and line 2. If resistance is measured go to next step.
 - A. Remove gear motor electrical cover, inspect terminal block and check wire resistance.
 - B. Disconnect and test capacitor.
 - C. Jumper capacitor wires and retest gearmotor for resistance.
 - D. Replace gear motor assembly
3. If the gear motor trips on overload immediately or intermittently:
 - A. Premix 11 ounces of cleaner with 6 ounces of water in a non metallic container.
 - B. Add the entire solution to the evaporator and allow to soak for a minimum of 4 hours.
 - C. Test run and check operation. If the issue is not resolved, proceed with the next step.
4. Disconnect evaporator from gear motor assembly and test run the gear motor. Replace gearmotor assembly or refer to evaporator diagnostics.

EVAPORATOR ASSEMBLY

Function

Freezes water to the evaporator wall and the ice is removed with an auger. The auger transfers the shaved ice upward where it is compressed through an extruder and exits the top of the evaporator.

Check procedure

The most common failure is a buildup of lime scale or minerals on the evaporator wall and auger. This buildup applies additional pressure on the evaporator assembly and results in rotation sensor trips, gearmotor trips or mechanical failure of the evaporator.

1. Water leakage is normally a failed seal due to a buildup of scale and mineral or a bearing failure. Disassembly, inspection and cleaning are required when water leakage is present.
2. Cleaning - For all other issues cleaning is the first step:
 - A. Premix 11 ounces of cleaner with 6 ounces of water in a non metallic container.
 - B. Add the entire solution to the evaporator and allow to soak for a minimum of 4 hours.
 - C. Test run and check operation. If the issue is not resolved, proceed with the next step.
3. Disassemble, inspect and clean components with a cloth soaked in ice machine cleaner. Removing the ice chute will expose the ice breaker and extruder cover. Removing the extruder cover allen bolts will allow the auger assembly to be lifted and removed from the evaporator barrel for inspection and cleaning. Refer to exploded view for disassembly and identification. Clean and replace parts as required.

COMPRESSOR ELECTRICAL DIAGNOSTICS

The compressor does not start or will trip repeatedly on overload.

Check Resistance (Ohm) Values

NOTE: Compressor windings can have very low ohm values. Use a properly calibrated meter.

Perform the resistance test after the compressor cools. The compressor dome should be cool enough to touch (below 120°F/49°C) to assure that the overload is closed and the resistance readings will be accurate.

SINGLE PHASE COMPRESSORS

1. Disconnect power then remove the wires from the compressor terminals.
2. The resistance values between C and S and between C and R, when added together, should equal the resistance value between S and R.
3. If the overload is open, there will be a resistance reading between S and R, and open readings between C and S and between C and R. Allow the compressor to cool, then check the readings again.

CHECK MOTOR WINDINGS TO GROUND

Check continuity between all three terminals and the compressor shell or copper refrigeration line. Scrape metal surface to get good contact. If continuity is present, the compressor windings are grounded and the compressor should be replaced.

COMPRESSOR DRAWING LOCKED ROTOR

To determine if the compressor is seized, check the amp draw while the compressor is trying to start.

The two likely causes of this are a defective starting component or a mechanically seized compressor.

To determine which you have:

1. Install high and low side gauges.
2. Try to start the compressor.
3. Watch the pressures closely.
 - A. If the pressures do not move, the compressor is seized. Replace the compressor.
 - B. If the pressures move, the compressor is turning slowly and is not seized. Check the capacitors and relay.

COMPRESSOR DRAWING HIGH AMPS

The continuous amperage draw on start-up should not be near the maximum fuse size indicated on the serial tag.

DIAGNOSING START COMPONENTS

If the compressor attempts to start, or hums and trips the overload protector, check the start components before replacing the compressor.

Capacitor

Visual evidence of capacitor failure can include a bulged terminal end or a ruptured membrane. Do not assume a capacitor is good if no visual evidence is present. A good test is to install a known good substitute capacitor. Use a capacitor tester when checking a suspect capacitor. Clip the bleed resistor off the capacitor terminals before testing.

Relay

The relay has a set of contacts that connect and disconnect the start capacitor from the compressor start winding. The contacts on the relay are normally closed (start capacitor in series with the start winding). The relay senses the voltage generated by the start winding and opens the contacts as the compressor motor starts. The contacts remain open until the compressor is de-energized.

RELAY OPERATION CHECK

1. Disconnect wires from relay terminals.
2. Verify the contacts are closed.
Measure the resistance between terminals 1 and 2. No continuity indicates open contacts. Replace the relay.
3. Check the relay coil.
Measure the resistance between terminals 2 and 5. No resistance indicates an open coil. Replace the relay.

COMPRESSOR ELECTRICAL DIAGNOSTICS

Location

On the base unit behind the rear panels.

Specification

R-290 220-240/50 - 1/5HP, TL4CN

Check Procedure - The compressor does not start or will trip repeatedly on overload

CHECK RESISTANCE (OHM) VALUES

Compressor windings can have very low ohm values. Use a properly calibrated meter.

Perform the resistance test after the compressor cools. The compressor dome should be cool enough to touch (below 120°F/49°C) to assure that the overload is closed and the resistance readings will be accurate.

SINGLE PHASE COMPRESSORS

Disconnect power, then remove the wires from the compressor terminals.

The resistance values between C and S and between C and R, when added together, should equal the resistance value between S and R.

If the overload is open, there will be a resistance reading between S and R, and open readings between C and S and between C and R. Allow the compressor to cool, then check the readings again.

CHECK MOTOR WINDINGS TO GROUND

Check continuity between all three terminals and the compressor shell or copper refrigeration line. Scrape metal surface to get good contact. If continuity is present, the compressor windings are grounded and the compressor should be replaced.

COMPRESSOR DRAWING LOCKED ROTOR

To determine if the compressor is seized, check the amp draw while the compressor is trying to start.

The two likely causes of this are a defective starting component and a mechanically seized compressor.

To determine which you have:

Install high and low side gauges.

Try to start the compressor.

Watch the pressures closely.

If the pressures do not move, the compressor is seized.

Replace the compressor.

If the pressures move, the compressor is turning slowly and is not seized. Check the capacitors and relay.

COMPRESSOR DRAWING HIGH AMPS

The continuous amperage draw on start-up should not be near the maximum fuse size indicated on the serial tag.

DIAGNOSING CAPACITORS

If the compressor attempts to start, or hums and trips the overload protector, check the starting components before replacing the compressor.

Visual evidence of capacitor failure can include a bulged terminal end or a ruptured membrane. Do not assume a capacitor is good if no visual evidence is present.

Use a capacitor tester when checking a suspect capacitor. Clip the bleed resistor off the capacitor terminals before testing.

If the compressor hums and will not start but the windings are OK. Replace the start capacitor.

A good test is to install a known good substitute capacitor.

FILTER-DRIERS**Location**

Ice maker: Behind the compressor & cabinet: between compressor and condenser coil.

Function

To remove moisture and particulates from the refrigerant. This will prevent premature failure of the compressor and blocking of restrictor devices.

Specification

The size of the filter-drier is important due to a critical refrigerant charge. Using an improperly sized filter-drier will cause the refrigeration system to be improperly charged with refrigerant.

Driers are covered as a warranty part. The drier must be replaced any time the system is opened for repairs. Refer to the parts manual for the recommended OEM field replacement drier.

Check Procedure

The drier should not alter the temperature of the refrigerant. Compare the temperature of the copper pipe either side of the filter/drier, they should be the same.

If there is a temperature drop that indicates a partial blockage of the filter/drier and it should be replaced.

4.

Refrigerated Cabinet

TEMPERATURE THERMISTOR - NOZZLE & CABINET PROBES ONLY

Location

- Nozzle Thermistor - Behind the front fascia inside the duct area connected to the product line.
- Cabinet Thermistor - Attached to the evaporator plate in the base unit.
- Defrost Thermistor - Inserted into the evaporator coil.

Function

Supplies input to the SRB board to indicate nozzle, cabinet or defrost temperature. The SRB board energizes and de-energizes the compressor based on input from the thermistors.

Specifications

5,000 Ohms \pm 2% at 25°C (77°F)

16,330 Ohms \pm 2% at 0°C (32°F)

Check Procedure

NOTE: Use a multimeter to check operation.

1. Reboot machine by moving toggle switch off/on.
2. Inspect for correct wiring on the SRB Board.
 - Nozzle connection terminal J33
 - Cabinet connection terminal J32
 - Defrost connection terminal J34
3. Isolate by disconnecting the wiring connectors.
4. Check continuity across the terminals with an ohm meter.
 - Resistance = Thermistor is good.
 - Open (OL) = Replace thermistor.

NOTE: These thermistors are identical. Swapping the thermistor connections at the SRB board can be used for diagnostics.

Temperature/Resistance Chart

This chart is used for the temperature control thermistors. As the temperature rises at the thermistor block, the resistance drops.

If the ohmmeter reads "OL", check the scale setting on the meter before assuming the thermistor is bad.

°C	°F	OHM
-17.8	0	43,297
-15.0	5	36,503
-12.2	10	30,884
-9.4	15	26,948
-6.7	20	22,928
-3.9	25	20,082
-1.1	30	17,188
1.7	35	14,751
4.4	40	13,019
7.2	45	11,506
10.0	50	9,951

DUCT FAN MOTOR**Location**

Top of the base cabinet below the duct opening.

Function

Moves cool air from the cabinet through the tubing chase to maintain cabinet temperature in the beverage lines.

Specifications

24 VDC 2.4 watt

Check Procedure

1. Check wiring connections on SRB terminal J36.
2. Isolate by disconnecting the wiring connectors.
3. Check continuity across the terminals with an ohm meter.
 - Resistance of $17M\Omega \pm 10\%$ = Motor is good.
 - Open (OL) = Replace motor.
4. Check rotor for excessive play or binding.

CONDENSER FAN MOTOR**Location**

At the rear of the base unit, behind the panels on the condensing unit.

Function

Moves air through the condenser to condense refrigerant from vapor to liquid state.

Specification

230 VAC 9 watts

Check Procedure

1. Isolate by disconnecting the main power supply.
2. Check that the fan blade is secured to the motor.
3. Check the blade spins freely.
4. Check rotor for excessive play or binding.
5. Remove the wiring from the terminal connectors and check continuity across the terminals with an ohm meter.
 - Resistance = Motor windings are good.
 - Open (OL) = Replace motor.

Refrigerant Recovery/Evacuation**SELF-CONTAINED MODEL PROCEDURE**

Do not purge refrigerant to the atmosphere. Capture refrigerant using recovery equipment. Follow the manufacturer's recommendations.

Important

Multiplex assumes no responsibility for the use of contaminated refrigerant. Damage resulting from the use of contaminated refrigerant is the sole responsibility of the servicing company.

Important

Replace the liquid line drier after recovering the refrigerant and before evacuating and recharging. Use only a Multiplex (OEM) liquid line filter-drier to prevent voiding the warranty.

Connections

Manifold gauge sets must utilize low loss fittings to comply with U.S. Government rules and regulations.

Make these connections:

- Suction side of the compressor through the suction service valve.
- Discharge side of the compressor through the discharge service valve.

Self-Contained Recovery/Evacuation

1. Place ice machine rocker in off.
2. Install manifold gauges, scale and recovery unit or two-stage vacuum pump and open high and low side on manifold gauges.

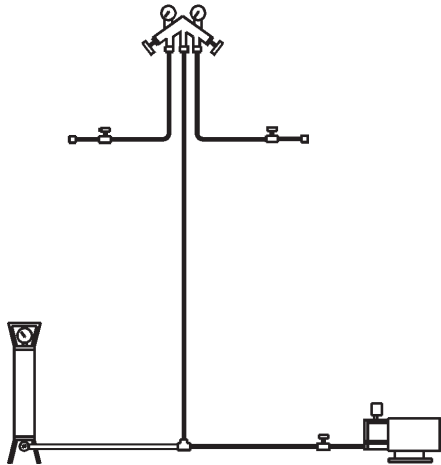

RECOVERY/EVACUATION CONNECTIONS

3. Perform recovery or evacuation:
 - A. Recovery: Operate the recovery unit as directed by the manufacturer's instructions.
 - B. Evacuation prior to recharging: Pull the system down to 500 microns. Then, allow the pump to run for an additional half hour. Turn off the pump and perform a standing vacuum leak check.
4. Follow the Charging Procedures. *See Self-Contained Charging Procedures page 80*

Self-Contained Charging Procedures**Important**

The charge is critical on all Multiplex ice machines. Use a scale to ensure the proper charge is installed.

1. Be sure the ice machine is off.

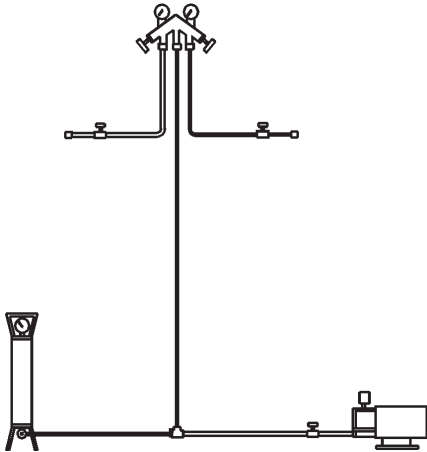
**CHARGING CONNECTIONS**

2. Close the vacuum pump valve, the low side service valve, and the low side manifold gauge valve.
3. Open the high side manifold gauge valve.
4. Open the charging cylinder and add the proper refrigerant charge (shown on nameplate) through the discharge service valve.
5. Let the system "settle" for 2 to 3 minutes.
6. Close the high side on the manifold gauge set.
7. Press the power button.
8. Add any remaining refrigerant through the suction service valve (if necessary).

NOTE: Manifold gauges must be removed properly to ensure that no refrigerant contamination or loss occurs.

9. Make sure that all of the vapor in the charging hoses is drawn into the ice machine before disconnecting the charging hoses.
 - A. Run the ice machine in freeze cycle.
 - B. Remove the high side low loss fitting from the access valve.
 - C. Open the high and low side valves on the manifold gauge set. Any refrigerant in the lines will be pulled into the low side of the system.
 - D. Allow the pressures to equalize while the ice machine is in the freeze cycle.
 - E. Remove the hoses from the ice machine and install the caps.

System Contamination Clean-Up

GENERAL

This section describes the basic requirements for restoring contaminated systems to reliable service.

Important

Multiplex assumes no responsibility for the use of contaminated refrigerant. Damage resulting from the use of contaminated refrigerant is the sole responsibility of the servicing company.

DETERMINING SEVERITY OF CONTAMINATION

System contamination is generally caused by either moisture or residue from compressor burnout entering the refrigeration system.

Inspection of the refrigerant usually provides the first indication of system contamination. Obvious moisture or an acrid odor in the refrigerant indicates contamination.

If either condition is found, or if contamination is suspected, use a Total Test Kit from Totaline or a similar diagnostic tool. These devices sample refrigerant, eliminating the need to take an oil sample. Follow the manufacturer's directions.

If a refrigerant test kit indicates harmful levels of contamination, or if a test kit is not available, inspect the compressor oil.

1. Remove the refrigerant charge from the ice machine.
2. Remove the compressor from the system.
3. Check the odor and appearance of the oil.
4. Inspect open suction and discharge lines at the compressor for burnout deposits.
5. If no signs of contamination are present, perform an acid oil test.

Check the chart to determine the type of cleanup required.

Contamination Cleanup Chart	
Symptoms/Findings	Required Cleanup Procedure
No symptoms or suspicion of contamination	Normal evacuation/recharging procedure
Moisture/Air Contamination symptoms Refrigeration system open to atmosphere for longer than 15 minutes Refrigeration test kit and/or acid oil test shows contamination No burnout deposits in open compressor lines	Mild contamination cleanup procedure
Mild Compressor Burnout symptoms Oil appears clean but smells acrid Refrigeration test kit or acid oil test shows harmful acid content No burnout deposits in open compressor lines	Mild contamination cleanup procedure
Severe Compressor Burnout symptoms Oil is discolored, acidic, and smells acrid Burnout deposits found in the compressor, lines, and other components	Severe contamination cleanup procedure

CLEANUP PROCEDURE**Mild System Contamination**

1. Replace any failed components.
2. If the compressor is good, change the oil.
3. Replace the liquid line drier.

Important

Dry nitrogen is recommended for this procedure.
This will prevent release of refrigerants.

4. Follow the normal evacuation procedure, except replace the evacuation step with the following:
 - A. Pull vacuum to 1000 microns. Break the vacuum with dry nitrogen and sweep the system. Pressurize to a minimum of 5 psig (35 kPa,.35 bar).
 - B. Pull vacuum to 500 microns. Break the vacuum with dry nitrogen and sweep the system. Pressurize to a minimum of 5 psig (35 kPa,.35 bar).
 - C. Change the vacuum pump oil.
 - D. Pull vacuum to 500 microns. Run the vacuum pump for 1/2 hour on self-contained models, 1 hour on remotes.

NOTE: You may perform a standing vacuum test to make a preliminary leak check. You should use an electronic leak detector after system charging to be sure there are no leaks.

5. Charge the system with the proper refrigerant to the nameplate charge.
6. Operate the ice machine.

Severe System Contamination

1. Remove the refrigerant charge.
2. Remove the compressor and inspect the refrigeration lines. If burnout deposits are found, install a new TXV.
3. Wipe away any burnout deposits from suction and discharge lines at compressor.
4. Sweep through the open system with dry nitrogen.
5. Install a new compressor and new start components.
6. Install a suction line filter-drier with acid and moisture removal capability. Place the filter drier as close to the compressor as possible.
7. Install an access valve at the inlet of the suction line drier.
8. Install a new liquid line drier.

9. Follow the normal evacuation procedure, except replace the evacuation step with the following:
 - A. Pull vacuum to 1000 microns. Break the vacuum with dry nitrogen and sweep the system. Pressurize to a minimum of 5 psig (35 kPa,.35 bar).
 - B. Change the vacuum pump oil.
 - C. Pull vacuum to 500 microns. Break the vacuum with dry nitrogen and sweep the system. Pressurize to a minimum of 5 psig (35 kPa,.35 bar).
 - D. Change the vacuum pump oil.
 - E. Pull vacuum to 500 microns. Run the vacuum pump for 1/2 hour on self-contained models, 1 hour on remotes.

NOTE: You may perform a standing vacuum test to make a preliminary leak check. You should use an electronic leak detector after system charging to be sure there are no leaks.

10. Charge the system with the proper refrigerant to the nameplate charge.
11. Operate the ice machine for one hour. Then, check the pressure drop across the suction line filter-drier.
 - A. If the pressure drop is less than 1 psig (7 kPa,.7 bar), the filter-drier should be adequate for complete cleanup.
 - B. If the pressure drop exceeds 1 psig (7 kPa,.7 bar), change the suction line filter-drier and the liquid line drier. Repeat until the pressure drop is acceptable.
12. Operate the ice machine for 48-72 hours. Then remove the suction line drier and change the liquid line drier.
13. Follow normal evacuation procedures.

REPLACING PRESSURE CONTROLS

Without Removing Refrigerant Charge

This procedure reduces repair time and cost. Use it when any of the following components require replacement, and the refrigeration system is operational and leak-free.

- Fan cycle control (air cooled only)
- High pressure cut-out control
- Low Pressure cut-out control
- High side service valve
- Low side service valve

Important

This is a required in-warranty repair procedure.

1. Disconnect power.
2. Follow all manufacturer's instructions supplied with the pinch-off tool. Position the pinch-off tool around the tubing as far from the pressure control as feasible. Clamp down on the tubing until the pinch-off is complete.

Warning

Do not unsolder a defective component. Cut it out of the system. Do not remove the pinch-off tool until the new component is securely in place.

3. Cut the tubing of the defective component with a small tubing cutter.
4. Solder the replacement component in place. Allow the solder joint to cool.
5. Remove the pinch-off tool.
6. Re-round the tubing. Position the flattened tubing in the proper hole in the pinch-off tool. Tighten the wing nuts until the block is tight and the tubing is rounded.

NOTE: The pressure controls will operate normally once the tubing is re-rounded. Tubing may not re-round 100%.

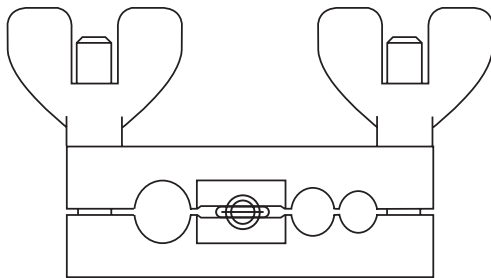

USING PINCH-OFF TOOL

THIS PAGE INTENTIONALLY LEFT BLANK

Charts

Total System Refrigerant Charge

This information is for reference only. Refer to the Blend-In-Cup Beverage System model/serial number tag to verify the system charge. Serial plate information overrides information listed on these pages.

⚠ Warning

Refrigerant type and amount varies by model. Machines may use R-404A or R-290 refrigerant. Always refer to model/serial plate to identify refrigerant type and amount.

⚠ Warning

Some 50Hz models may contain up to 150 grams of R-290 (propane) refrigerant. R-290 (propane) is flammable in concentrations of air between approximately 2.1% and 9.5% by volume (LEL lower explosion limit and UEL upper explosion limit). An ignition source at a temperature higher than 470°C is needed for a combustion to occur. Refer to nameplate to identify the type of refrigerant in your equipment.

Important

Due to continuous improvements, this information is for reference only. Please refer to the serial number tag to verify electrical data. Serial tag information overrides information listed on this page.

Model	System	Refrigerant
FB081TF	1 (Lower Cabinet)	R404A 8 oz (226.8 g)
	2 (Ice Maker)	
FB081TP	1 (Lower Cabinet)	R290 3.53 oz. (100 g)
	2 (Ice Maker)	

24-Hour Ice Production/ Refrigerant Pressure Charts

These charts are used as guidelines to verify correct ice machine operation.

Accurate collection of data is essential to obtain the correct diagnosis.

- Ice production checks that are within 10% of the chart are considered normal. This is due to variances in water and air temperature. Actual temperatures will seldom match the chart exactly.
- Due to the critical refrigerant amount, verify operational temperatures with an electronic thermometer. Install gauges only when necessary.
- All discharge and suction line temperature readings are taken within 6" of the compressor.
- Low-loss fittings connected directly to the gauge are required for refrigerant pressure readings. Do not use a manifold gauge set unless recovering/charging.
- Zero out refrigeration gauges before obtaining pressure readings to avoid mis-diagnosis.
- Allow system to stabilize for a minimum of 10 minutes, then verify the temperatures/pressures are within the ranges indicated.
- Water temperature will affect suction and discharge temperature/pressure - 50°F (10°C) water temperature will result in temperatures/pressures on the lower end of the ranges specified. 90°F (32°C) water temperatures will result in temperatures/pressures on the upper end of the range specified.

FB081TF R404A REFRIGERANT CHART

Characteristics vary depending on operating conditions.

24 hour production

R-404a Ice Production		
Air Temperature/ Water Temperature	24 Hour Ice Production	kWh/100 lbs (45 kg) @ 90°/70°F (32°/21°C)
70°/50°F (21°/10°C)	261 lbs (118 kg)	8.69
90°/70°F (32°/21°C)	185 lbs (84 kg)	
Water usage/100 lbs./45.4 kgs of Ice		
Potable Water: 12 gallons, 45.4 liters		

Operating temperatures R404A

Air Temperature Around the Unit	Discharge Temperature At Compressor	Suction Temperature At Compressor
70°F 21° C	180-190 82-88	32-37 0-3
90°F 32° C	205-215 96-102	38-43 3-6
110°F 43° C	227-237 108-114	40-45 4-7

Due to the critical refrigerant amount, verify operational temperatures with an electronic thermometer.

All discharge and suction line temperature readings are taken within 6" of the compressor.

Install gauges only when necessary to diagnose failed components.

Operating Pressures R404A

Air Temperature Around the Unit °F/°C	Discharge Pressure PSI kPa	Suction Pressure PSI kPa
70/21	210-230 1448-1586	28-33 193-228
90/32	290-310 1999-2137	32-37 221-255
110/43	355-375 2448-2586	36-41 248-283

FB081TP R290 REFRIGERANT CHART

Characteristics vary depending on operating conditions.

24 hour production

Air Temperature Water Temperature °F/°C	24 hour Production
70°/21° 50°/10°	591 lbs 268 kgs
90°/32° 70°/21°	451 lbs 204 kgs

Operating temperatures R290

Air Temperature Around the Unit	Discharge Temperature At Compressor	Suction Temperature At Compressor
70°F 21° C	180-190 82-88	30-35 -1 - 2
90°F 32° C	205-215 96-102	36-41 2-5
110°F 43° C	135-146 113-118	40-45 4-7

Due to the critical refrigerant amount, verify operational temperatures with an electronic thermometer.

All discharge and suction line temperature readings are taken within 6" of the compressor.

Install gauges only when necessary to diagnose failed components.

Operating Pressures R290

Air Temperature Around the Unit °F/°C	Discharge Pressure PSI kPa	Suction Pressure PSI kPa
70/21	160-180 71-82	22-28 -6 - -2
90/32	205-225 96-107	23-29 -5 - -2
110/43	275-295 135-146	26-32 -3 - 0

Nominal Operating Voltage

NOMINAL OPERATING VOLTAGE FOR LOADED ELECTRICAL COMPONENTS

Component	High Voltage AC	24V DC Voltage	Low Voltage AC	Modbus	Other
Gear Motor, Ice Maker	X				
Compressor, Ice Maker	X				
Condenser Fan, Ice Maker	X				
Evaporator Fan, Refrigerator Base	X				
Evaporator Fan, Duct		X			
Condenser Fan, Refrigerator Base	X				
Compressor, Refrigerator Base	X				
Mixer/Blender, Linear Motor, Rotation Motor	X	X	X		
Relay	X	X			
Power Supply - High Voltage to 24V DC Transformer	X	X (OUT)			
UI Assembly (Board, Touchpad)		X		X	
Mixer/Blender Board Assembly	X	X		X	
SRB Assembly, Control Board to All Components	X	X	X	X	X

NOTE: Voltage into Load Component except as noted. High Voltage AC - Refer to Nameplate Rating. Low Voltage AC - Less than 10V AC. Other - Refer to Tech Manual for details.

NOMINAL OPERATING VOLTAGE FOR SENSORS

Component	High Voltage AC	24V DC Voltage	Low Voltage AC	Modbus	Other
Temperature - Drive, Defrost, Nozzle, Cabinet			X		X
Ice Bin Level		X			
Ice Position Dispense Wheel		X			
Mixer/Blender, Limit Switches		X	X		
High Pressure Switch - Refrigeration		X			
Water Sensor Reservoir Ice Maker			X		
Mixer/Blender Door Switches		X			

NOTES: Voltage into Load Component except as noted. High Voltage AC - Refer to Nameplate Rating. Low Voltage AC - Less than 10V AC. Other - Refer to Tech Manual for details.

THIS PAGE INTENTIONALLY LEFT BLANK

INTERCONNECT WIRING DIAGRAM

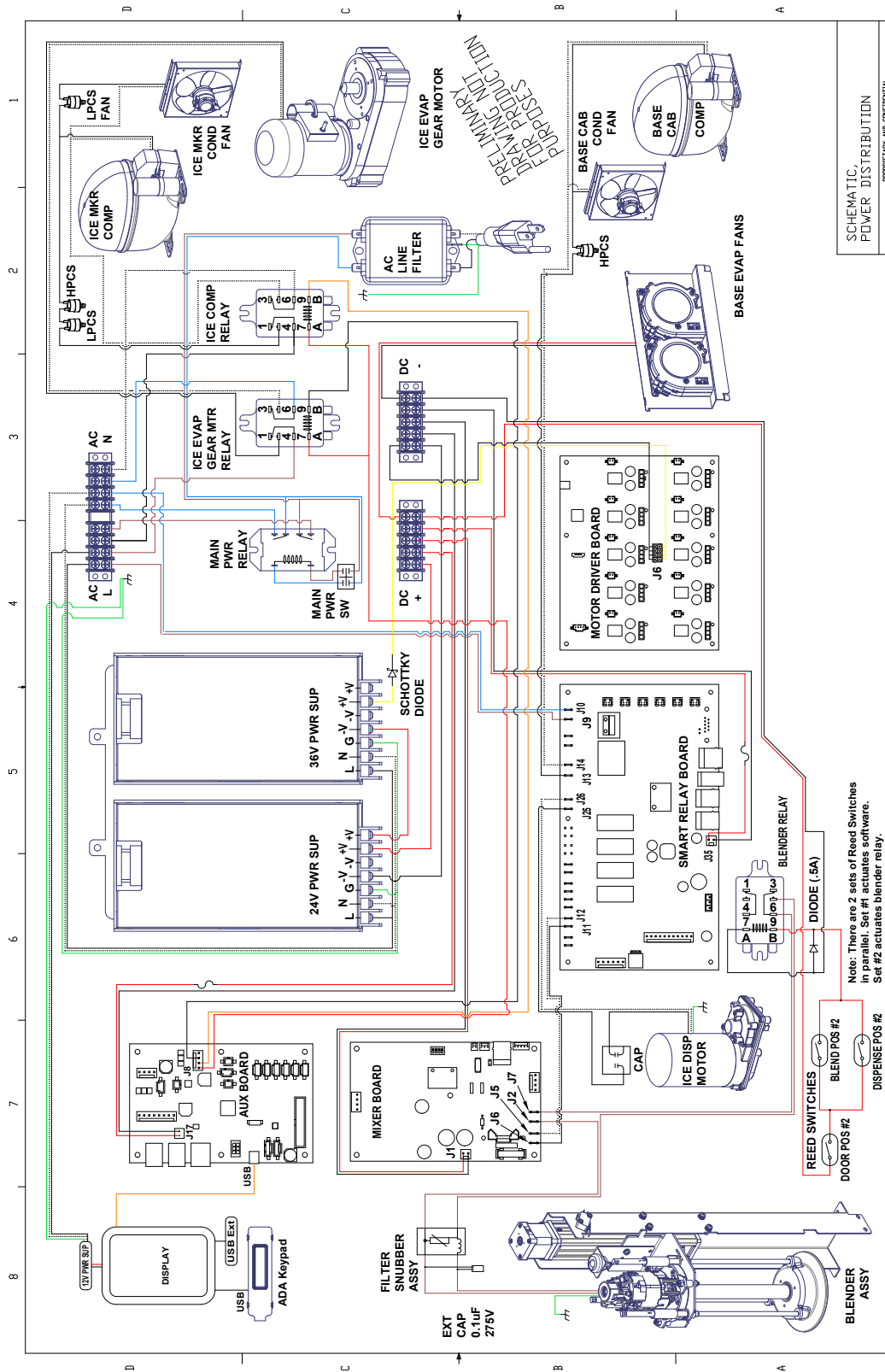

SCHEMATIC,
POWER DISTRIBUTION
PROPRIETARY AND CONFIDENTIAL

PLUMBING DIAGRAM

1. Water pressure regulator (NEFF Engineering [PN: NE-REG-H20-NSF]) (QTY:1)
2. 7-valve solenoid manifold (MAC Valves [SMA-2572]) (QTY: 1)
3. Float chamber (Welbilt [PN: 000006515]) (QTY: 1)
4. Gear motor / Evaporator ass'y (Welbilt [PN: 000008223]) (QTY: 1)
5. Liquid dispense valve (Deltrol [PN: DS/V12N-2LSX-024D-82SR]) (QTY: 1)
6. Valve (Aptar Midland [PN: V21-200]) (QTY: 12)
7. 8-valve solenoid manifold (MAC Valves [SMA-2573]) (QTY: 1)
8. Check valve (McMaster-Carr [PN: 7933K330]) (QTY: 1)
9. Xylem CIP pump (Flojet [PN: RLP22202T]) (QTY: 1)
10. Sanitation fitting (Welbilt [PN: WBL-33-065]) (QTY: 8)

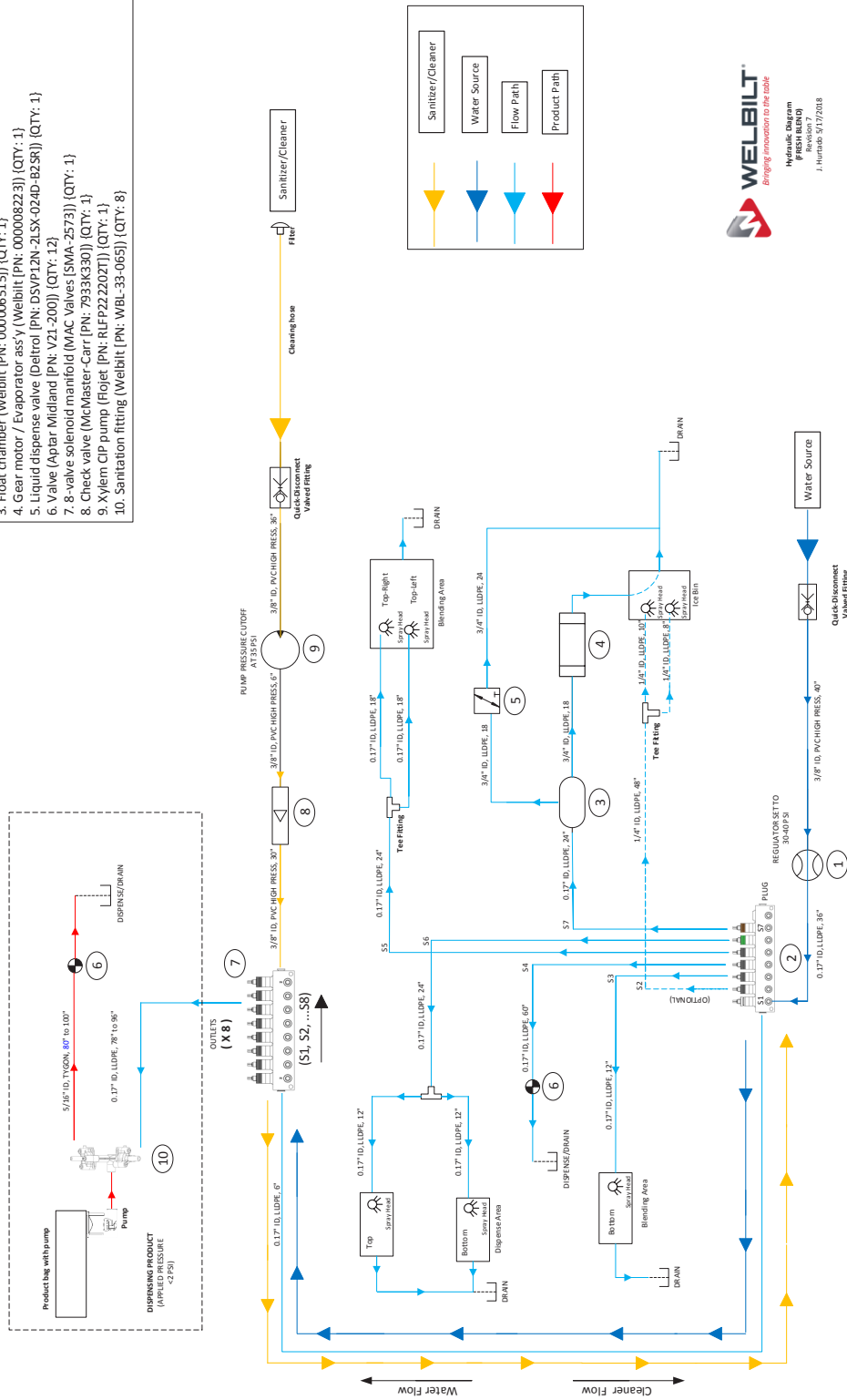

ICE MACHINE REFRIGERATION TUBING SCHEMATIC

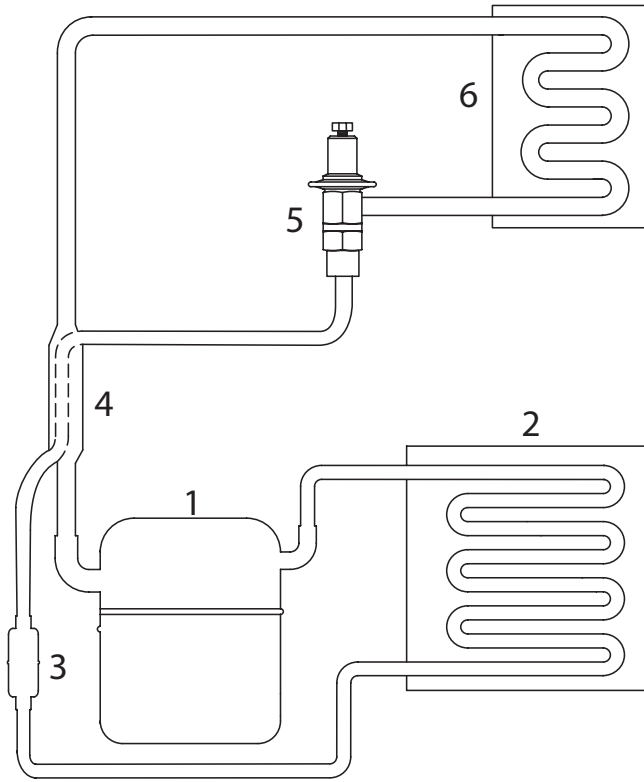

1	Compressor
2	Condenser
3	Liquid Line Filter Drier
4	Heat Exchanger
5	Expansion Valve
6	Evaporator

Every new piece of Welbilt equipment comes with KitchenCare® and you choose the level of service that meets your operational needs from one restaurant to multiple locations.

StarCare – Warranty & lifetime service, certified OEM parts, global parts inventory, performance audited

ExtraCare — CareCode, 24/7 Support, online/mobile product information

LifeCare – Install & equipment orientation, planned maintenance, KitchenConnect™, MenuConnect®

Talk with KitchenCare® • 1-844-724-CARE • www.mtwkitchencare.com

To learn how Welbilt and its leading brands can equip you, visit our global web site at www.welbilt.com, then discover the regional or local resources available to you.

