

Blend-in-Cup[®] (BIC) Manual Fill Beverage System

Service Manual

This manual is updated as new information and models are released. Visit our website for the latest manual.
www.manitowocfsg.com



Safety Notices

As you work on Manitowoc equipment, be sure to pay close attention to the safety notices in this manual. Disregarding the notices may lead to serious injury and/or damage to the equipment.

Throughout this manual, you will see the following types of safety notices:

Warning

Text in a Warning box alerts you to a potential personal injury situation. Be sure to read the Warning statement before proceeding, and work carefully.

Caution

Text in a Caution box alerts you to a situation in which you could damage the equipment. Be sure to read the Caution statement before proceeding, and work carefully.

Procedural Notices

As you work on Manitowoc equipment, be sure to read the procedural notices in this manual. These notices supply helpful information which may assist you as you work.

Throughout this manual, you will see the following types of procedural notices:

Important

Text in an Important box provides you with information that may help you perform a procedure more efficiently. Disregarding this information will not cause damage or injury, but it may slow you down as you work.

NOTE: Text set off as a Note provides you with simple, but useful, extra information about the procedure you are performing.

Read These Before Proceeding

Caution

Proper installation, care and maintenance are essential for maximum performance and trouble-free operation of your equipment. Visit our website www.manitowocfsg.com for manual updates, translations, or contact information for service agents in your area.

Important

Routine adjustments and maintenance procedures outlined in this manual are not covered by the warranty.

Warning

Read this manual thoroughly before operating, installing or performing maintenance on the equipment. Failure to follow instructions in this manual can cause property damage, injury or death.

Warning

Do not use electrical appliances or accessories other than those supplied by Manitowoc for your ice machine model.

Warning

Two or more people or a lifting device are required to lift this appliance.

Warning

This equipment contains high voltage electricity and refrigerant charge. Installation and repairs are to be performed by properly trained technicians aware of the dangers of dealing with high voltage electricity and refrigerant under pressure. The technician must also be certified in proper refrigerant handling and servicing procedures. All lockout and tag out procedures must be followed when working on this equipment.

Warning

Do not damage the refrigeration circuit when installing, maintaining or servicing the unit.

⚠ Warning

Do not operate equipment that has been misused, abused, neglected, damaged, or altered/modified from that of original manufactured specifications. This appliance is not intended for use by persons (including children) with reduced physical, sensory or mental capabilities, or lack of experience and knowledge, unless they have been given supervision concerning use of the appliance by a person responsible for their safety. Do not allow children to play with this appliance.

⚠ Warning

All covers and access panels must be in place and properly secured, before operating this equipment.

⚠ Warning

Do not obstruct machine vents or openings.

⚠ Warning

Do not store gasoline or other flammable vapors or liquids in the vicinity of this or any other appliance.

⚠ Warning

Do not clean with water jet.

⚠ Warning

It is the responsibility of the equipment owner to perform a Personal Protective Equipment Hazard Assessment to ensure adequate protection during maintenance procedures.

⚠ Warning

When using electric appliances, basic precautions must always be followed, including the following:

- a. Read all the instructions before using the appliance.
- b. To reduce the risk of injury, close supervision is necessary when an appliance is used near children.
- c. Do not contact moving parts.
- d. Only use attachments recommended or sold by the manufacturer.
- e. Do not use outdoors.
- f. For a cord-connected appliance, the following must be included:
 - Do not unplug by pulling on cord. To unplug, grasp the plug, not the cord.
 - Unplug from outlet when not in use and before servicing or cleaning.
 - Do not operate any appliance with a damaged cord or plug, or after the appliance malfunctions or is dropped or damaged in any manner. Contact the nearest authorized service facility for examination, repair, or electrical or mechanical adjustment.
- g. Follow applicable lock out tag out procedures before working on equipment.
- h. Connect to a properly grounded outlet only.

THIS PAGE INTENTIONALLY LEFT BLANK

Table of Contents

Section 1 General Information

Model Numbers	9
Model Nomenclature:	9
About Blend-In-Cup	9
Serial Number Location	9
Specifications	10
Dimensions.....	10
Capacity & Weight.....	10
Product Delivery Location.....	11
Refrigerant Charge.....	11
Electrical	12
Air / CO ₂ , Plain & Chilled Water	13
System Pressures	13
Regulator Settings & Location	14
Drain Connections	14

Section 2 Installation

Step-by-Step Installation	15
Pre-installation Checklist.....	15
Connections	16
Start-up & Cleaning	17
Serial Number.....	17
Post Installation Checklist	19

Section 3 Operation

Sequence of Operation	21
Product Dispense Operation	21
Operation	21
Refrigerated Cabinet Operation	22
Normal Operations	22
Evaporator & Condenser Fan Motor Operation.....	22
Operation in the Clean/Sanitize Cycle	22
Adaptive Defrost.....	22
High Temp Alarm.....	22
Thermistor Failure	22
Other Operations	23
Recommended Cups.....	23
Changing the Cup Dispenser Size	23
Manual Fill Ice	23

**Section 4
Maintenance**

General Maintenance.....25
 Daily, Weekly, Monthly 25
 Quarterly & Biannual 25
 Annual, Shutdown & Start-up..... 25
 Door Gasket Maintenance 25
 Drain Maintenance - Inside Lower Cabinet..... 25
 Refrigerator..... 26
 Stainless Steel Care & Cleaning 26
 Doors/Hinges..... 26
 Preventing Corrosion 26
 Cleaning Kits 26
 Other Monthly Tasks..... 27
Daily Cleaning - Zone 128
Weekly Cleaning - Zone 228
Product Line Flush.....29
Annual Planned Maintenance29

**Section 5
Troubleshooting**

Store Manager Level31
 Before Calling For Service Checklist 31
Technician Level33
This troubleshooting is to be used only by qualified service technicians.33
Display Errors33
 Control System 35
 Beverage System 36
 Water System Checklist..... 37
 Blender Controls Flowchart 38
 Blender Controls Flowchart (Continued)..... 39
Refrigerated Cabinet.....40
 Refrigerated Cabinet Flowchart 40
 Reach-in Temperature Out of Range 42
 High Product Temperature 43
Refrigeration System Diagnostics44
 Analyzing Discharge Pressure or Temperature..... 44
 Analyzing Suction Pressure or Temperature 44
Procedure to Clear Blocked Line45
How to Check Air/CO₂ Pressure46
 How to Adjust Air/CO₂ Pressure 47
How to Check Plain Water Pressure48

**Section 6
Controls**

Touch Screens49
 Drink Selection Screen 49
 Flavor Selection Screen 50
 Size Screen 50
 Main Menu Screen 52
 Manager's Menu Screen..... 53
 Updates..... 61
 Product Inventory Screen..... 68

Cleaning Screen 70

Section 7

Component Check Procedures

Component Identification 71
 External 71
 Internal 72
Control System 74
 ON/OFF Rocker Switch 74
 Power Relay 74
 Power Supply 75
 UI (User Interface - Touchscreen) 75
 SRB Board 77
 Blender Control Board 79
 Syrup Solenoid Valve 80
 Non Drip Valve 81
 Product Pump 81
 Step Motor 82
 Blender Motor 82
 Home Position Switch 83
 Door Switches 83
 Water Rinse Solenoid Valve 84
Refrigerated Cabinet 85
 Temperature Thermistor - Nozzle, Cabinet or Defrost 85
 Evaporator Fan Motor 86
 Duct Fan Motor 86
 Condenser Fan Motor 86
 Compressor Drawing Locked Rotor 87
 Diagnosing Capacitors 87
Filter-Driers 87

Section 8

Charts

Total System Refrigerant Charge 89
Nominal Operating Voltage 90
 Nominal Operating Voltage for Loaded Electrical Components 90
 Nominal Operating Voltage for Sensors 90

Section 9

Diagrams

Wiring & Plumbing Diagrams 91
 Control Boards Wiring Diagram 92
 Lower Refrigeration Cabinet Wiring Diagram 93
 Shaver Motor & Harness Wiring 93
 Lower Refrigeration Cabinet Plumbing Diagram 94
 Product Plumbing & LMS Valve Layout 95
 Dispense System Diagram 96

THIS PAGE INTENTIONALLY LEFT BLANK

Section 1

General Information

Model Numbers

This manual covers the following models:

MA-8-2, MA-8-2BF, MA-8-2AF

MODEL NOMENCLATURE:

MA - 8 - 1 6 - XXXX

I	II	III	IV	V
Brand Name	Number of Flavors	Blenders	Ice Capacity (Not used on Manual Fill)	Optional Customer Specific Characters
MA (Manual Fill)	8	1 = One Blenders		
	6	2 = Two Blender		

About Blend-In-Cup

The Blend-In-Cup beverage system is a self-contained dispensing unit that allows the operator to make flavor combinations of blended and non-blended drinks. It holds product flavoring in a refrigerated reach-in base enclosure, has a refrigerated ice making machine and includes one or two mixing modules.

The operator controls and accesses the unit using a lighted touch screen. Icons on the drink selection screens represent the primary flavor combinations for the drinks. There are multiple drink size options. Menu changes and additions are uploaded using a USB mass storage device and the Menu Connect Software platform.

On-screen instructions also include operator procedures for cleaning/sanitizing, checking inventory, replacing product bags, selecting drink sizes and manually preparing drinks. Managers and technicians have access to menu/software updates, diagnostics and other service screens.

NOTE: These units are intended for indoor use.

Serial Number Location

The Blend-In-Cup beverage system serial number is listed on the serial number decal affixed to the middle of the lower back panel. Another serial number decal is located on the right side of the machine.

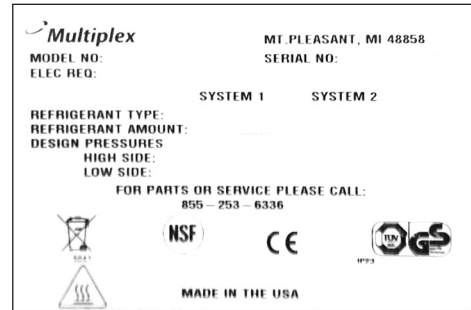

Sample Serial Tag

Specifications

DIMENSIONS

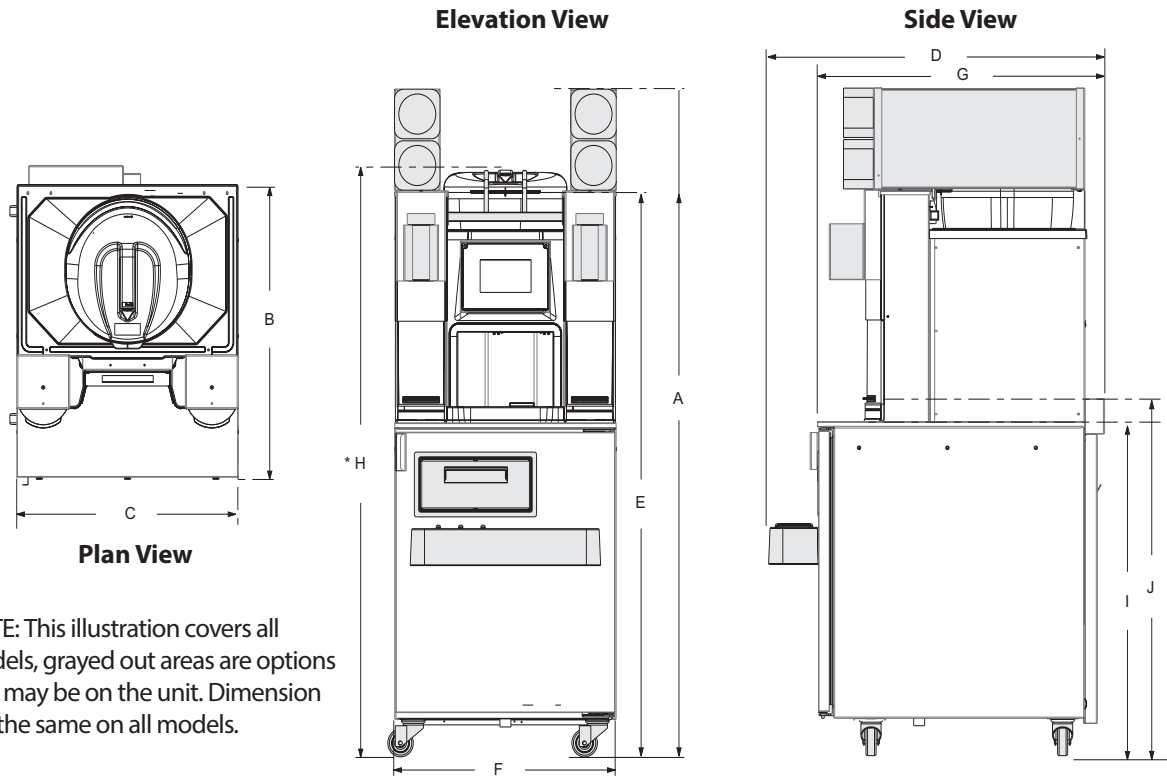

NOTE: This illustration covers all models, grayed out areas are options that may be on the unit. Dimension C is the same on all models.

* Low profile casters reduce height by 1.5" (4 cm)

A	71.25" (181 cm)	C	26.00" (66 cm)	E	60.25" (153 cm)	G	33.74" (86 cm)	I	36.15" (92 cm)
B	32.82" (83 cm)	D	40.10" (102 cm)	F	26.00" (66 cm)	*H	63.48" (161 cm)	J	39.09" (99 cm)

Warning

To avoid instability the installation area must be capable of supporting the weight of the equipment and a full bin of ice. Additionally the equipment must be level side to side and front to back.

CAPACITY & WEIGHT

	Ice Capacity	HP	Max Product Bin Load	Shipping Weight	Empty Weight	Full Weight
Lower Cabinet	–	1/5	19.8 lbs (9 kg)	461 lbs (209 kg) Crated	347 lbs (157 kg)	500 lbs (227 kg)
Ice Bin	23 lbs (10 kg)	–	–		Unpacked No Ice/Product	With Ice/Product

PRODUCT DELIVERY LOCATION

The location selected for the Blend-In-Cup Beverage System must meet the following criteria.

- The air temperature must be at least 40°F (4°C), but must not exceed 90°F (32°C), climate class 4.
- The location must not be near heat-generating equipment or in direct sunlight and must be protected from weather.
- Plain or Chilled Inlet Water Temperature: min/max = 40°F / 90°F (4°C / 32°C).
- Always use the water supply line supplied when installing this appliance. Never reuse an old supply line.
- Verify floor of install location is level front to back, side to side.
- Keep equipment area clear of combustible material.

⚠ Warning

Carbon Dioxide (CO₂) displaces oxygen. Exposure to a high concentration of CO₂ gas causes tremors, which are followed rapidly by loss of consciousness and suffocation. If a CO₂ gas leak is suspected, particularly in a small area, immediately ventilate the area before repairing the leak. CO₂ lines and pumps must not be installed in an enclosed space. An enclosed space can be a cooler or small room or closet. This may include convenience stores with glass door self serve coolers. If you suspect CO₂ may build up in an area, venting of the B-I-B pumps and / or CO₂ monitors must be utilized.

Clearances

Top	18" (46 cm)
Sides	0" (0 cm)
Back	6" (15 cm)
Front	30" (76 cm)

⚠ Warning

Do not obstruct machine vents or openings.

Heat of Rejection

Models	Heat of Rejection BTU/h
R404a Base Cabinet (Cabinet 1)	2100

REFRIGERANT CHARGE

Important

Due to continuous improvements, this information is for reference only. Please refer to the serial number tag to verify electrical data. Serial tag information overrides information listed on this page.

	R-404a
Lower Cabinet (Cabinet 1)	12 oz. (339 g)

Electrical

⚠ Warning
All wiring must conform to local, state and national codes.

Minimum Circuit Ampacity

The minimum circuit ampacity is used to help select the wire size of the electrical supply. (Minimum circuit ampacity is not the Blend-In-Cup Beverage System’s running amp load.) The wire size (or gauge) is also dependent upon location, materials used, length of run, etc., it must be determined by a qualified electrician.

Electrical Requirements

Refer to Blend-In-Cup Beverage System Model/Serial Plate for voltage/ampere specifications.

⚠ Caution

Operate equipment only on the type of electricity indicated on the specification plate.

Voltage

The standard voltage is 230 VAC-50 Hz. A dedicated electrical circuit is required, a power cord is provided with all units.

Some models are available in different voltages and may be equipped with a different plug, for details on each model always refer to the serial number tag to verify electrical data.

Minimum Circuit Amperage Chart

Important

Due to continuous improvements, this information is for reference only. Please refer to the serial number tag to verify electrical data. Serial tag information overrides information listed on this page.

Model	Voltage/Cycle/ Phase	Total Amps	Breaker Size (Max)
MA-8-2	120/60/1	8.6	20A
MA-8-2BF	220/60/1	5.0	
MA-8-2AF	230-240/50/1		

Grounding Instructions

⚠ Warning

The machine must be grounded in accordance with national and local electrical codes.

This appliance must be grounded. In the event of malfunction or breakdown, grounding provides a path of least resistance for electric current to reduce the

risk of electric shock. This appliance is equipped with a cord having an equipment-grounding conductor and a grounding plug. The plug must be plugged into an appropriate outlet that is properly installed and grounded in accordance with all local codes and ordinances.

Bonding Instructions (230-240V 50 Hz Models Only)

This appliance must be connected to the potential equalization system in accordance with EN60335-1 and EN60335-2-75. A bonding lug is provided on the lower right front corner of the appliance.

⚠ Warning

This machine must be connected to the potential equalization system.

⚠ Warning

When using electric appliances, basic precautions must always be followed, including the following:

- a. Read all the instructions before using the appliance.
- b. To reduce the risk of injury, close supervision is necessary when an appliance is used near children.
- c. Do not contact moving parts.
- d. Only use attachments recommended or sold by the manufacturer.
- e. Do not use outdoors.
- f. For a cord-connected appliance, the following must be included:
 - Do not unplug by pulling on cord. To unplug, grasp the plug, not the cord.
 - Unplug from outlet when not in use and before servicing or cleaning.
 - Do not operate any appliance with a damaged cord or plug, or after the appliance malfunctions or is dropped or damaged in any manner. Contact the nearest authorized service facility for examination, repair, or electrical or mechanical adjustment.
- g. Follow applicable lock out tag out procedures before working on equipment.
- h. Always unplug before replacing the lamp. Replace the bulb with the same type.
- i. Connect to a properly grounded outlet only. See Grounding Instructions.

AIR / CO₂, PLAIN & CHILLED WATER

⚠ Warning

Connect to a potable water supply only.

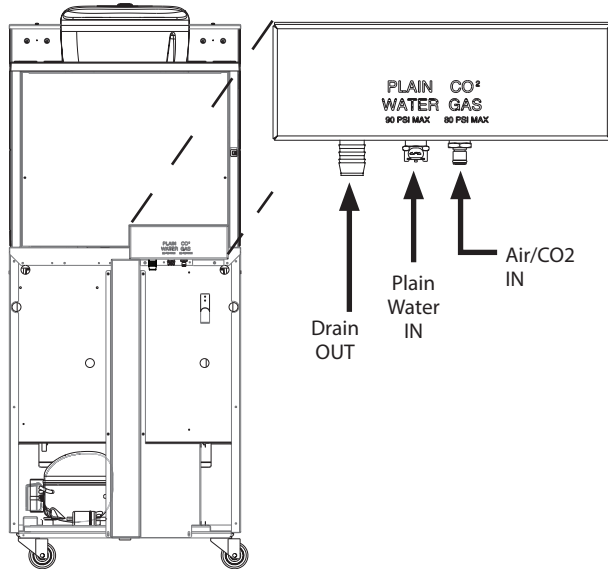

- Use supplied 3/8" (.95 cm) panel-mounted hose barb and 6' (1.8 m) of beverage tubing to connect labeled coupling body fitting(s) on back of unit for each supply connection.
- Do not connect either water connection to a hot water supply. Be sure all hot water restrictors installed for other equipment are working. (Check valves on sink faucets, dishwashers, etc.)
- Install a water shut-off valve in the water line at the rear of the machine.
- Insulate water inlet lines to prevent condensation.

Hard Water

In areas where the water is highly concentrated with minerals the water should be tested by a water treatment specialist, and the recommendations of the specialist regarding filtration and/or treatment should be followed.

SYSTEM PRESSURES

Supply to the Unit

⚠ Warning

Do not supply more than 80 psi (0.551 MPa , 551 kPa, 5.51 bar) Air/CO₂ to the unit, excessive pressure to product pumps may cause failure.

This table shows the Minimum / Maximum supply of Water and Air/CO₂ required at the rear of the machine at no flow conditions.

	MINIMUM	MAXIMUM
Air / CO₂ Supply	50 psi (.345 MPa, 345 kPa, 3.45 bar)	80 psi (0.551 MPa, 551 kPa, 5.51 bar)
Plain Water Supply	65 psi (0.448 MPa, 448 kPa, 4.48 bar)	90 psi (0.620 MPa, 620 kPa, 6.20 bar)

REGULATOR SETTINGS & LOCATION

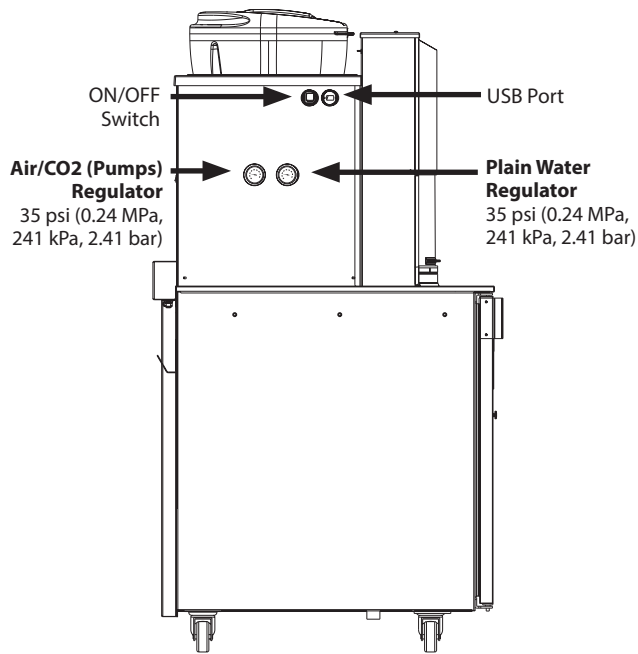

Regulator Settings

Important

Air/CO₂ Requires the pressure measurement to be taken only when a product pump is being activated (product pump during flow conditions).

Important

Water requires the pressure measurement to be taken only when rinse water is spraying (flowing conditions) in a blender chamber.

Important

Water pressure affects the blender area cleaning, a water booster may be required if pressure is too low.

REGULATOR	SETTINGS (During Flowing Conditions)
Pumps Air / CO₂	35 psi (0.24 MPa, 241 kPa, 2.41 bar)
Plain Water	35 psi (0.24 MPa, 241 kPa, 2.41 bar)

DRAIN CONNECTIONS

- Connect supplied 1" ID hose to hose-barb connection on machine.
- Drain lines must have a 1.5 inch drop per 5 feet of run (2.5 cm per meter), and must not create traps.
- The floor drain must be large enough to accommodate drainage from all drains.
- An air gap is included in the design of the machine for back flow prevention. Plumb to local code.

Section 2 Installation

Step-by-Step Installation

These instructions are provided to assist the qualified installer. Contact your Manitowoc Foodservice Service Agent or call Manitowoc Foodservice for information regarding start-up services.

Important

Failure to follow these installation guidelines may affect warranty coverage.

PRE-INSTALLATION CHECKLIST

- Keep product bags in a cooler at least 24 hours prior to installation.
- Any damage should be noted and reported to the delivering carrier immediately.
- Check the lower portion of the unit to be sure casters are not bent.
- Visually inspect the refrigeration package, compressor compartment housing. Be sure lines are secure and base is still intact.
- Inspect installation location behind the BIC for electrical outlet location, CO₂, water hose fittings, and shutoff.
- Check voltage at outlet dedicated for BIC.
- Verify floor of install location is level front to back, side to side and all casters are touching the floor.

⚠ Warning

The mass of this appliance will allow it to move uncontrolled on an inclined surface. Adequate means must be provided to prevent uncontrolled movement at all times.

- Remove the side panels from the unit to make the board connections, Air/CO₂ and Water Regulator gauges accessible.
- Check that board connections are secure and did not vibrate loose during shipment.
- Check that both micro switches are in line with the motor above the blenders.

CONNECTIONS

See "System Pressures" on page 13 and "Regulator Settings & Location" on page 14

1. Confirm correct orientation of Water and Air/CO₂ fittings.
2. The line set included with the unit should be equipped with male quick connect fitting(s) for the water supply line(s) and female quick connect fitting(s) for the Air/CO₂ supply line

Important

Leave enough slack in the water/CO₂/drain lines to allow access to the rear of the machine without disconnecting the lines.

REGULATOR	SETTINGS (During Flowing Conditions)
Pumps Air / CO₂	35 psi (0.24 MPa, 241 kPa, 2.41 bar)
Plain Water	35 psi (0.24 MPa, 241 kPa, 2.41 bar)

Important

Regulators are factory set but will need to be checked and possibly adjusted under flowing conditions once the unit is operational.

See "How to Check Air/CO₂ Pressure" on page 46 and "How to Check Plain Water Pressure" on page 48

3. Coil excess tubing and secure with tie straps.

Drain

See "Drain Connections" on page 14

4. Route drain line (minimum 1" ID) to drain, maintaining a 2" (51 mm) air gap. Cut to proper length if needed (do not leave loops in drain).

Electrical

See "Electrical" on page 12

5. If all electrical and grounding requirements have been followed proceed to insert electrical plug from BIC into wall receptacle.
6. Turn power switch on the left hand side of the unit to the ON position.

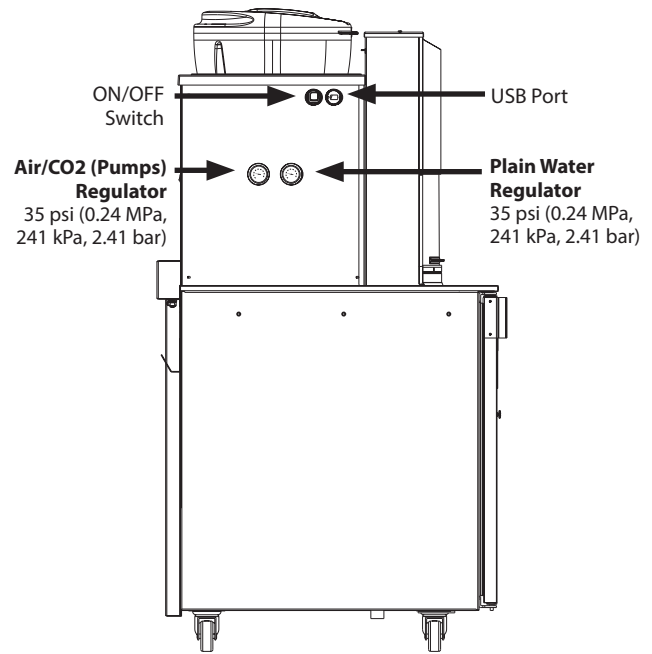

7. The touch screen should energize and inform the user to perform Zone 2 & 3 cleaning before the unit can be put into operation. See "Start-up & Cleaning" on page 17

Important

Do not add product to the machine until cleaning and sanitizing are complete.

START-UP & CLEANING

Checklist

Review before proceeding with Start-Up & Cleaning.

- All internal packing has been removed?
- Have all of the electrical, water and CO₂ connections been made?
- Is there proper clearance around the machine for air circulation?
- Is the machine grounded / polarity correct?
- Has the machine been installed where the incoming water temperature will remain in the range of 40°F / 90°F (4°C / 32°C)?
- Have the regulators been properly set?
- Have the blender door(s) sensor position(s) been checked?
- Has the Power switch been turned to the ON position?

Serial Number

8. During the first start-up of the machine the installer will be asked to input the unit's 13 digit serial number.
 - A. Enter the serial number.
 - B. Press the green check to continue.

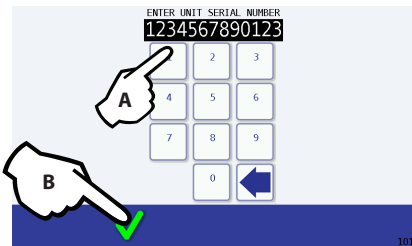

Set Flavors & Mixers

9. Installer must also choose the number of flavors and mixers to be configured before being granted access to the user interface.

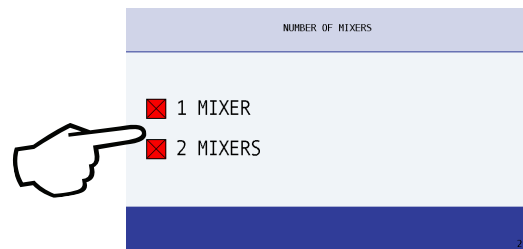
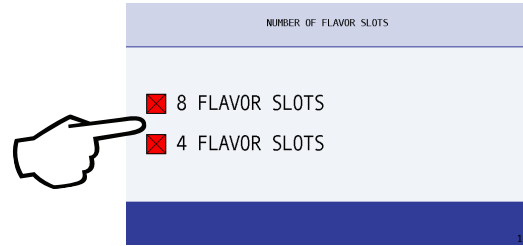

NOTE: These can be changed later through the Manager's Menu if needed.

Tune-Up Reminder

10. The Tune-Up reminder screen will appear during initial installation, press the green check to continue.



11. The red wrench at the top of the screen and reminder will periodically popup until the installation date is set in the Managers Menu.

NOTE: This will be done once Start-Up and Cleaning have been completed.

12. Press the Back Arrow in the lower left corner to access the Main Menu.



13. Select the Cleaning Icon.



14. Select Zone 2, Clean and sanitize the Blend-In-Cup machine by following the on screen instructions.

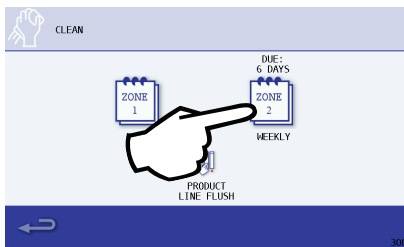

NOTE: See “Weekly Cleaning - Zone 2” on page 28. By doing so, the following will have been completed:

- A. All beverage lines, ice bin, dispense area, and blender chambers, cleaned and sanitized.
- B. Water run through the drain to verify it is draining properly.
- C. Verify all regulators are set correctly during cleaning.

NOTE: During the cleaning process is an ideal time to verify pressure regulator settings during flowing conditions. See “Regulator Settings & Location” on page 14

- D. Ice bin manually filled with ice. See “Manual Fill Ice” on page 23 .
- E. Product bags retrieved from walk-in cooler, installed into the product bins and placed into their proper location in the cabinet. See “Procedure to Install a Product Bag” on page 69 & “Assigning Flavors” on page 58.
- F. All product lines primed and ready for use.

Label

- 15. Add labels to product bins, put labels in correct place.
- 16. Add labels anywhere else on the unit required.

Software

- 17. Load recipes. See “Recipe Loading Procedure” on page 63.
- 18. Verify correct drinks and flavors are available.

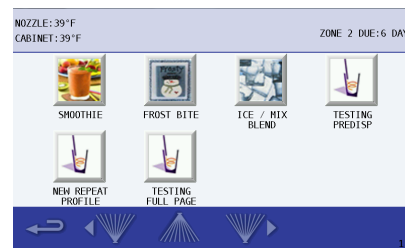

Drink Selection Screen

(Drink choices will vary depending on loaded recipe file)

Calibrate

See "Calibration Procedure" on page 59

19. Product calibration can be performed once operating temperature has been reached. Once completed, the Blend-In-Cup machine is ready for use.
20. Reinstall all side panels.
21. Push the BIC unit into place.
22. Verify the unit is level and shim if necessary.

Demonstrate

23. Demonstrate using the Interface. See "Touch Screens" on page 49.
24. Demonstrate how to make drink. See "Procedure to Make a Drink" on page 51.
25. Demonstrate Manager Menu options, using the default password. (The password can be changed.) See "Manager's Menu Screen" on page 53.
26. Set date and time to activate warranty.
27. Complete start-up form, sign, and have store manager sign form. (Fax to number on form.)

POST INSTALLATION CHECKLIST

- | | |
|--------------------------|--|
| <input type="checkbox"/> | Has the machine been properly sanitized? |
| <input type="checkbox"/> | Has each flavor been installed and primed? |
| <input type="checkbox"/> | Has ice been added to the bin? |
| <input type="checkbox"/> | Have the all regulators been correctly set during flowing conditions? |
| <input type="checkbox"/> | Is the machine cycling ON/OFF on the temperature control? |
| <input type="checkbox"/> | Has the owner/operator been instructed regarding maintenance procedures? |
| <input type="checkbox"/> | Has the owner/operator completed the warranty registration card? |

THIS PAGE INTENTIONALLY LEFT BLANK

Section 3 Operation

Sequence of Operation

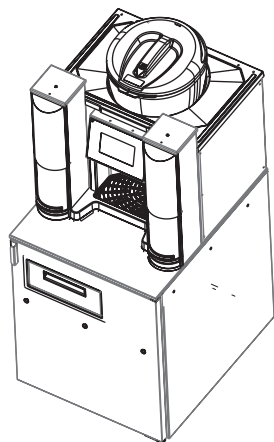

**Dual Blend Chamber
without
Cup Dispenser**

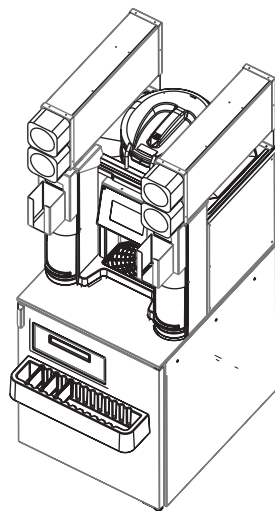

**Dual Blend Chamber
with Top Mount Cup
Dispenser**

Drink Selection screen appears after power-up of the unit. Operator presses one of the drink type buttons on the Drink Selection screen, and the Flavor Options screen appears. Once a flavor is selected, the Size screen appears. See "Procedure to Make a Drink" on page 51.

Next the drink preparation sequence commences. If add-ins are required for the drink, the user will be prompted. Here, according to the drink size selected and when initiated through the touch screen, the machine dispenses product and ice into the cup in the dispense area. The cup is then placed into an available blend chamber.

With the blend chamber door closed and after "Start Mixer" is selected on the touch screen, the machine blends the drink for the correct time at the proper blender speed. If add-ins are required for the drink after blending, the user will be prompted.

After the drink is removed and the operator closes the blend chamber door, the automatic rinse of the blender initiates. The Drink Selection screen re-appears.

Product Dispense Operation

The sequence varies according to the recipe. Some recipes will use one ingredient, others will use multiple ingredients. The sequence below uses one ingredient to simplify the sequence.

Prerequisites:

- Line voltage must be supplied
- CO₂ pressure is supplied and regulated to the correct pressure
- Product is inserted in cabinet and correctly connected to adapter/tubing
- Ice is available
- Water is supplied at the correct pressure
- A recipe has been developed in MenuConnect and transferred to the control board with a USB drive.

OPERATION

Selecting a drink from the touch screen will energize the following components for the time specified by the recipe:

- A. The ice dispense wheel turns to add ice.
- B. The water inlet valve opens to dispense water.
- C. The solenoid valve opens and supplies CO₂ to the product pump.
- D. The product pump energizes and pumps the product into the cup.

The cup is then transferred to a blending station.

Refrigerated Cabinet Operation

Default temperature set point = 2.2°C / 36° F with a 2.2°C / 4° F Differential.

Parameter	Default Setting	Minimum Setting	Maximum Setting
Set-point (°F)	36	32	38
Differential (°F)	4	1	6
Minimum Off Time (Min)	3	2	5
Defrost Run Time (Min)	180	120	240
Defrost Temperature (°F)	43	35	50
Defrost Time (Min)	15	10	20
Defrost Initiation Temperature (°F)	5	0	12
Default On Time (Min)	12	10	20
Default Off Time (Min)	3	2	5

NORMAL OPERATIONS

The microprocessor control board controls the cabinet temperature based on the input received from the cabinet temperature thermistor. The thermistor value is compared to the control board set point. When the reach-in temperature is equal or greater than the set point (plus half the differential), the compressor relay closes, provided the following conditions are satisfied:

- Power has been uninterrupted to the control board for a 3 minute period.

OR

- The 3 minute compressor time delay has expired. The delay period starts after the compressor has run and then cycles off.

The compressor relay opens when the reach-in temperature is less than the set point (minus half the differential).

EVAPORATOR & CONDENSER FAN MOTOR OPERATION

The condenser fan motor and compressor share the same relay. The evaporator fan motor relay is energized continuously and the evaporator fan runs continuously.

OPERATION IN THE CLEAN/SANITIZE CYCLE

During the weekly cleaning/sanitize cycle, the evaporator fan motor relay and the condenser fan motor/compressor relay remain energized.

ADAPTIVE DEFROST

After 3 hours of cumulative compressor run time, the compressor will be de-energized for fifteen (15) minutes.

HIGH TEMP ALARM

High temp alarm will display when product thermistor is above 5.5°C / 42°F for 30 minutes and the following conditions are satisfied:

- 3 hours since power is applied
- 1 hour since cleaning cycle

Error display will reset when the temperature reaches 5°C / 41°F or below.

THERMISTOR FAILURE

If the microprocessor control board receives an open or shorted cabinet thermistor signal, the following will happen:

1. A fault is displayed on the LCD screen
 - Cabinet sensor open

Or

2. The microprocessor will initiate a default sequence for the refrigeration system - 12 minutes on, 3 minutes off.
3. The default cycle continues until the fault is corrected or power is disconnected. See "Temperature Thermistor - Nozzle, Cabinet or Defrost" on page 107.

Other Operations

RECOMMENDED CUPS

The following are cup general guidelines. Cups outside these parameters may work - testing in the machine with the product will be necessary.

- Cup heights between 4.25" (10.8 cm) and 7.00" (17.8 cm).
- Cup opening diameter greater than 3.50" (8.9 cm) and less than 4.18" (10.6 cm).
- Cup base diameter greater than 2.38" (6.0 cm) and less than 2.62" (6.6 cm).

CHANGING THE CUP DISPENSER SIZE

Turn the inner dial so that the notch sets at 1, 2, 3 or 4. Setting 1 will hold the smallest cup and 4 the largest cup. When the dial moves from 1 to 2, the dispenser fingers retract and allow for a larger cup to be inserted.

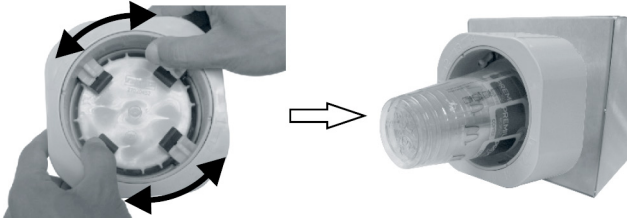

Position 1



Position 2



Position 3



Position 4

MANUAL FILL ICE

Procedure to add ice to the Ice bin.

1. Remove lid from ice bin and set aside.
2. Using a clean/sanitized container transfer ice from the back room ice machine to the ice bin.
3. Pour the ice from the transfer container into the ice bin until it is full; do not overfill.
4. Replace ice bin lid and verify lid seats in place.
5. The lid must fit in place to activate the ice bin lid switch

THIS PAGE INTENTIONALLY LEFT BLANK

Section 4 Maintenance

General Maintenance

This section covers common unit components and their care. The chart below is an overview of the maintenance that the end user and service technician should perform, and the frequency. These figures are the minimum required. If the Ice Machine is supplied with hard water, more frequent cleaning should be performed. If the condenser air filter is totally blocked, after one week, more frequent cleaning is recommended. (X = End User, S = Service Company)

DAILY, WEEKLY, MONTHLY

Maintenance	Daily	Weekly	Monthly
Blender / Dispense Area Cleaning/ Sanitizing (Zone 1 Cleaning)	X		
Product Line Cleaning & Sanitizing (Zone 2 Cleaning)		X	
Drain Cleaning		X	
Clean Air Filters			X
Clean Condenser Coil			
Check Ice Quality	X	X	

QUARTERLY & BIANNUAL

Maintenance	3 Months	6 Months
Blender / Dispense Area Cleaning/ Sanitizing (Zone 1 Cleaning)		
Product Line Cleaning & Sanitizing (Zone 2 Cleaning)		
Drain Cleaning		
Clean Air Filters		
Clean Condenser Coil	X	
Check Ice Quality		

ANNUAL, SHUTDOWN & START-UP

Maintenance	Annual	After Prolonged Shutdown	At Start-up
Blender / Dispense Area Cleaning/ Sanitizing (Zone 1 Cleaning)			
Product Line Cleaning & Sanitizing (Zone 2 Cleaning)		X	S
Drain Cleaning		X	
Clean Air Filters		X	
Clean Condenser Coil		X	
Check Ice Quality	S	S	S

⚠ Warning

Disconnect power to the unit before performing any service or maintenance functions.

Important

If the machine going to be shutdown for any length of time it is recommended to go through the Zone 2 - Weekly Cleaning both prior to turning off the unit and when returned to use.

If the unit is turned off, the product will no longer be kept cool in the refrigeration cabinet, remove all product bags and keep refrigerated to prevent spoilage.

DOOR GASKET MAINTENANCE

Door gaskets require regular cleaning to prevent mold and mildew buildup and also to retain the elasticity of the gasket. Gasket cleaning can be done with the use of warm soapy water. Avoid full strength cleaning products on gaskets as this can cause them to become brittle and crack. Never use sharp tools or knives to scrape or clean the gasket. Gaskets can be easily replaced and do not require the use of tools or an authorized service person. The gaskets are "Dart" style and can be pulled out of the groove in the door and new gaskets can be "pressed" back into place.

DRAIN MAINTENANCE - INSIDE LOWER CABINET

Each unit has a drain located inside the unit that removes the condensation from the evaporator coil and routes it to an external condensate evaporator pan. Each drain can become loose or disconnected during normal use. If you notice water accumulation on the inside of the unit, be sure the drain tube is connected to the evaporator drain pan. If water is collecting underneath the unit, make sure the end of the drain tube is in the condensate evaporator in the machine compartment. The leveling of the unit is important as the units are designed to drain properly when level. Be sure all drain lines are free of obstructions.

REFRIGERATOR**⚠ Warning**

Do not damage the refrigeration circuit when installing, maintaining or servicing the unit.

The interior and exterior can be cleaned using soap and warm water. If this isn't sufficient, try ammonia and water or a nonabrasive liquid cleaner. When cleaning the exterior, always rub with the "grain" of the stainless steel to avoid marring the finish. Do not use an abrasive cleaner because it will scratch the stainless steel and can damage the breaker strips and gaskets.

STAINLESS STEEL CARE & CLEANING

To prevent discoloration or rust on stainless steel, several important steps need to be taken. First, we need to understand the properties of stainless steel. Stainless steel contains 70-80% iron, which will rust. It also contains 12-30% chromium, which forms an invisible passive film over the steel's surface, which acts as a shield against corrosion. As long as the protective layer is intact, the metal is still stainless. If the film is broken or contaminated, outside elements can begin to break down the steel and begin to form discoloration or rust. Proper cleaning of stainless steel requires soft cloths or plastic scouring pads.

Important

Never Use Steel Pads, Wire Brushes or Scrapers!

Cleaning solutions need to be alkaline based or non-chloride cleaners. Any cleaner containing chlorides will damage the protective film of the stainless steel. Chlorides are also commonly found in hard water, salts, and household and industrial cleaners. If cleaners containing chlorides are used, be sure to rinse repeatedly and dry thoroughly. Routine cleaning of stainless steel can be done with soap and water. Extreme stains or grease should be cleaned with a non-abrasive cleaner and plastic scrub pad. Always rub with the grain of the steel. There are stainless steel cleaners available which can restore and preserve the finish of the steel's protective layer. Early signs of stainless steel breakdown are small pits and cracks. If this has begun, clean thoroughly and start to apply stainless steel cleaners in attempt to restore the passivity of the steel.

⚠ Caution

Never use an acid based cleaning solution! Many food products have an acidic content, which can deteriorate the finish. Be sure to clean the stainless steel surfaces of ALL food products. Common items include: tomatoes, peppers and other vegetables.

⚠ Caution

Never use a high-pressure water wash for this cleaning procedure as water can damage the electrical components located near or at the condenser coil.

DOORS/HINGES

Over time and with heavy use, doors and hinges may become loose. If this happens, tighten the screws that mount the hinge brackets to the frame of the unit. Loose or sagging doors can cause the hinges to pull out of the frame, which may damage both the doors and the hinges. In some cases this may require trained & qualified service agents or maintenance personnel to perform repairs.

NOTE: Do not place hot pans on/against the blue ABS liner. Do not throw items into the storage area. Failure to follow these recommendations could result in damage to the interior of the cabinet or to the blower coil. Overloading the storage area, restricting the airflow, and continuous opening and closing of the doors and drawers will hamper the unit's ability to maintain operational temperature.

PREVENTING CORROSION

Immediately wipe up all spills.

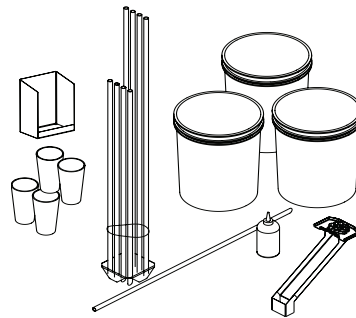
CLEANING KITS

Complete cleaning kits are available (part number 000-BIC-001Q). These kits include the following:

- (3) three 5 gallon buckets
- Bucket labels for Wash, Rinse, & Sanitizing
- Red & Blue Cups for blender cleaning
- Squeeze Bottle
- Dispense Area Shield
- Tubing Manifold for product line cleaning
- Ice Chute Assembly *

* Item included in with unit but not part of cleaning kit 000-BIC-001Q

OTHER MONTHLY TASKS

Air Filters

For units equipped with an air filter. Each month check the air filter to be sure it is clean and allows proper airflow.

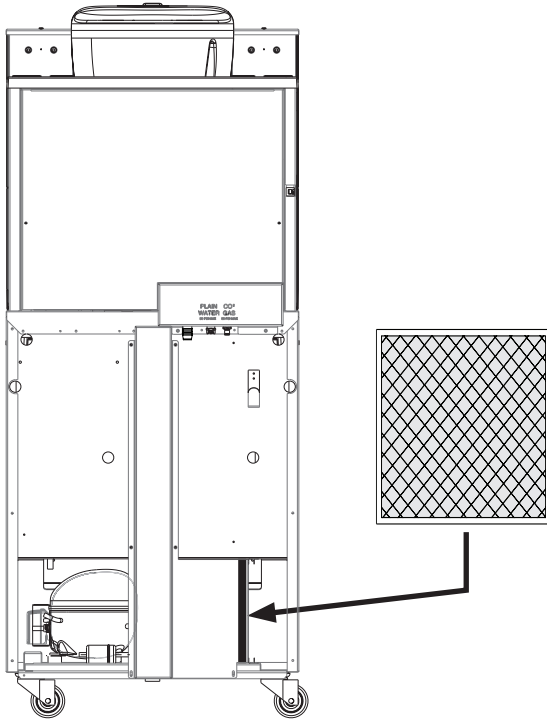

Air Filter Location

First access the rear of the unit, slide it out and inspect. If it is dirty or light will not pass through when held up to light, take to a sink and wash with dish soap until clean. DO NOT put in a dishwasher.

Once clean, slide it back into place on the unit and move unit back into place.

Cleaning the Condenser Coil

In order to maintain proper refrigeration performance, the condenser fins must be cleaned of dust, dirt and grease regularly. It is recommended that this be done at least every three months. If conditions are such that the condenser is totally blocked in three months, the frequency of cleaning should be increased. Clean the condenser with a vacuum cleaner or stiff brush. If extremely dirty, a commercially available condenser cleaner may be required.

Failure to maintain a clean condenser coil can initially cause high temperatures and excessive run times. Continuous operation with a dirty or clogged condenser coil can result in compressor failure. Neglecting the condenser coil cleaning procedures will void any warranties associated with the compressor and cost to replace the compressor.

Caution

Never use a high-pressure water wash for this cleaning procedure as water can damage the electrical components located near or at the condenser coil.

Daily Cleaning - Zone 1

Zone 1 cleaning is accessed through the cleaning icon on the touch screen. It covers the basic components of the BIC that will need cleaned on a daily basis.

NOTE: The on-screen instructions can vary depending on the recipe that was created with the MenuConnect program. All Zone 1 cleaning steps are covered in the Installation Operation & Maintenance manual that ships with the unit.

- Time to complete - 15 minutes

1. Cycle touch screen to the Main Menu and select the Cleaning icon.



2. In the Cleaning screen select the ZONE 1 icon.

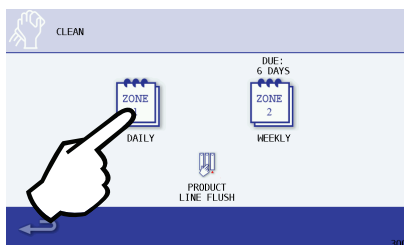

Exterior Cleaning

Remove dust and dirt from the exterior surfaces with a mild household dish washing detergent and warm water. Wipe dry with a clean, soft cloth.

Use cleaners designed for use with stainless steel products.

Heavy stains should be removed with stainless steel wool. Never use plain steel wool or abrasive pads. They will scratch the panels.

Plastic exterior panels and UI (User Interface) Screen should be cleaned with a mild household dish washing detergent and warm water on a damp cloth. Wipe dry with a clean, soft cloth.

Weekly Cleaning - Zone 2

Zone 2 cleaning is accessed through the cleaning icon on the touch screen. It covers all the steps that will need to be performed to complete the weekly cleaning.

NOTE: The on-screen instructions can vary depending on the recipe that was created with the MenuConnect program or options chosen in the Managers Menu. All Zone 2 cleaning steps are covered in the Installation Operation & Maintenance manual that ships with the unit.

- Time to complete - 90 Minutes

NOTE: An additional 1 hour 45 minutes will be needed if the Sanitizing Ice bin option is enabled in the Managers Menu.

1. Cycle touch screen to the Main Menu and select the Cleaning icon.

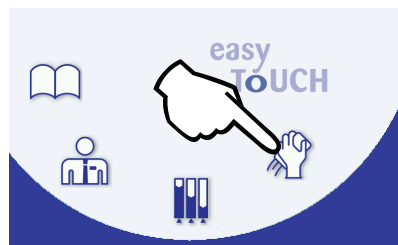

2. In the Cleaning screen select the ZONE 2 icon.

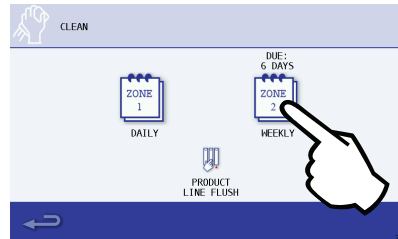

NOTE: Failure to complete the weekly cleaning sequence entirely will not reset the weekly cleaning timer and will require the process to be repeated.

Product Line Flush

The Product Line Flush procedure allows a user to choose which lines to flush instead of being forced to flush every product line in the unit.

Product Line Flush is accessed through the cleaning icon on the touch screen. It covers all the steps that will need to be performed to complete Product Line Flushing.

NOTE: The on-screen instructions can vary depending on the recipe that was created with the MenuConnect program or options chosen in the Managers Menu. All Product Line Flush steps are covered in the Installation Operation & Maintenance manual that ships with the unit.

1. Cycle touch screen to the Main Menu and select the Cleaning icon.

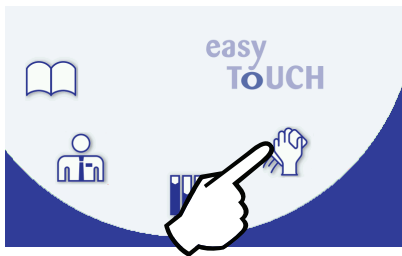

2. In the Cleaning screen select the PRODUCT LINE FLUSH icon.

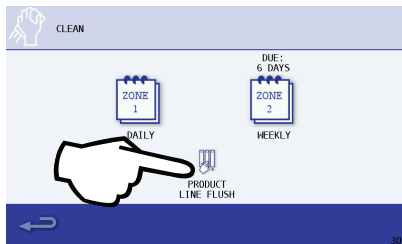

NOTE: Performing the product line flush through this interface procedure will not reset the Zone 2 cleaning countdown timer, Zone 2 cleaning will need to be performed in its entirety in order to reset the counter.

Annual Planned Maintenance

The following parts are recommended for annual planned maintenance replacement to ensure optimum unit performance and minimize downtime:

- Refrigerator door gasket (cleaning may be sufficient)
- Two (2) #6 O-rings for the water and CO₂/air quick connect lines
- Nine (9) LMS valves
- (1 Or 2) Mixer assemblies
- Ice Dispense Wheel
- Blender Shaft Assemblies

NOTE: All planned maintenance must be done by an approved, certified Manitowoc Field Service Technician.

THIS PAGE INTENTIONALLY LEFT BLANK

Section 5 Troubleshooting

Store Manager Level

The checklist below can be used by a store manager or used to verify a manager has done before calling service. Routine adjustments and maintenance procedures are not covered by the warranty.

BEFORE CALLING FOR SERVICE CHECKLIST





Symptom	Possible Cause	Corrective Action
Display Screen is off or refrigeration system is not running	Fuse blown or circuit breaker tripped.	Replace fuse or reset circuit breaker.
	Power cord unplugged.	Plug in power cord.
	Thermostat set too high.	Set thermostat to lower temperature.
	Main power switch turned off.	Turn main power switch on.
Display screen is on, but does not respond to commands	No recipe installed.	Develop recipe in MenuConnect and transfer to control system with USB drive.
	Control board locked up.	Reboot by disconnecting and reconnecting the main power supply.
Recipe does not dispense correctly	Low CO ₂ pressure.	Replace CO cylinder, set regulator to correct pressure. See "System Pressures" on page 13.
	No water supply or Low water pressure.	Restore water supply, set regulator to correct pressure. See "System Pressures" on page 13.
	Product is not installed, is installed incorrectly, or product line is blocked.	Install product, re-install correctly. See "Procedure to Clear Blocked Line" on page 77.
	Ice does not dispense.	Call for service.
Blender does not start when cup is inserted	Blender door is not closed.	Close blender door.
	Blender door switch is not closing.	Call for service.
Compressor runs for long periods or continuously	Excessive amount of warm product placed in cabinet.	Allow adequate time for product to cool down.
	Prolonged door openings or door(s) ajar.	Make sure door(s) are closed when not in use. Avoid prolonged door openings.
	Door gasket(s) not sealing properly.	Check gasket condition. Adjust door or replace gasket if necessary.
	Dirty condenser coil.	Clean the condenser coil.
	Evaporator coil iced over.	Turn unit off and allow coil to defrost. Make sure thermostat is not set too cold. Also, check gasket condition.





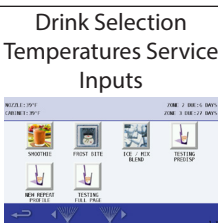
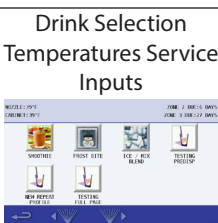

Symptom	Possible Cause	Corrective Action
Cabinet temperature is too high	Thermostat set too high.	Set thermostat to lower temperature.
	Evaporator Fan(s) will not operate or fan blade is off or spinning on shaft.	Call for service.
	Excessive amount of warm product placed in cabinet.	Allow adequate time for product to cool down.
	Prolonged door openings or door(s) ajar.	Make sure door(s) are closed when not in use. Avoid prolonged door openings.
	Dirty condenser coil.	Clean the condenser coil.
	Evaporator coil iced over.	Turn unit off and allow coil to defrost. Make sure thermostat is not set too cold. Also, check door gasket condition.
	System low on refrigerant.	Call for service - Service company must locate and repair leak, recover, evacuate and recharge.
	Compressor will not start - hums and trips on overload protector.	Clean the condenser coil. Move cabinet or make other adjustments to gain proper cabinet clearances. See "Clearances" on page 11. Check and correct incoming voltage to cabinet.
Cabinet is noisy	Loose part(s).	Locate and tighten loose part(s).
	Tubing vibration.	Ensure tubing is free from contact with other tubing or components.
Refrigerator is freezing product	Thermostat is set too low.	Set thermostat to higher temperature. See "Normal Operations" on page 24.
Will Not Dispense Ice	Ice bin cover not in position.	Make sure ice bin cover is in place and secure.
	Excessive amount of ice in ice bin causing the cover not to correctly close.	Remove excessive ice from bin and correctly place ice bin cover.
	Excessive vibration disengages lid.	Verify ice is in bin.
Light corrosion is present on whipped cream door or other stainless steel parts.	Environmental factors, hard water, salts, over use of chloride based cleaners and/or food products with acidic content.	Wipe up all spills immediately. Use nylon brush, soft cloth, soap, and water to clean and remove corrosion. See "Pre-installation Checklist" on page 17.

Technician Level

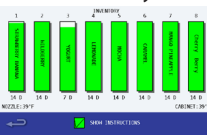
This troubleshooting is to be used only by qualified service technicians.

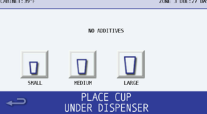
Display Errors

Screen	Display Shows	Error	Description of Error Condition	System Response to Error	Service
	DEFROSTING	None	None	Normal operation	Refer to defrost chart in technical manual.
	CABINET PROBE FAILURE: CHECK CABINET TEMPERATURE	Base Sensor temperature will display Open / Shorted	Cabinet Sensor input to A/D open / shorted circuit detected.	System shall go into fail-safe refrigeration mode. Compressor on for 12 minutes, off for 3 minutes. Temperature display shall change to "OPEN / SHORTED".	Check connection onto SRB. See "SRB Board" on page 97. Check sensor resistance. See "Temperature/Resistance Chart" on page 107.
	NOZZLE SENSOR TEMPERATURE WILL DISPLAY OPEN / SHORTED	Nozzle Sensor temperature will display Open / Shorted	Nozzle Sensor input to A/D open / shorted circuit detected.	System shall go into fail-safe refrigeration mode. Compressor on for 12 minutes, off for 3 minutes. Temperature display shall change to "OPEN / SHORTED".	Check connection onto SRB. See "SRB Board" on page 97. Check sensor resistance. See "Temperature/Resistance Chart" on page 107.
	DEFROST TEMP 'OPEN / SHORTED'		Defrost Sensor input to A/D open / shorted circuit detected.	System shall go into fail-safe refrigeration mode. Compressor on for 12 minutes, off for 3 minutes. Temperature display shall change to "OPEN / SHORTED".	Check connection onto SRB. See "SRB Board" on page 97. Check sensor resistance. See "Temperature/Resistance Chart" on page 107.
	ERROR HIGH PRODUCT TEMPERATURE	High Temperature	Cabinet or nozzle temperature high for extended time.	Interrupt home screen and default screens only.	Check connection onto SRB. See "SRB Board" on page 97. Check sensor resistance. See "Temperature/Resistance Chart" on page 107. Check refrigeration system, Air filter, fan, air restriction. See "Refrigerated Cabinet" on page 107.
	YELLOW BORDER, YELLOW BAR	Near Expiration	2 hours left until product expiration.	Highlight icon(s) of drink(s) affected with Yellow border.	See "Procedure to Install a Product Bag" on page 87.

<p>Drink Flavor & Inventory</p> 	<p>YELLOW BORDER, YELLOW BAR</p>	<p>Inventory Low</p>	<p>Inventory low based on calculated remaining weight.</p>	<p>Highlight icon(s) of drink(s) affected with Yellow border</p>	<p>See "Procedure to Install a Product Bag" on page 87.</p>
<p>Drink Flavor & Inventory</p> 	<p>"INVALID RECIPE FLAVOR(S) NOT INSTALLED OR FLAVOR(S) EXPIRED OR SLOT NEEDS CLEANING FLAVOR X"</p>	<p>Expired Product</p>	<p>Product expired.</p>	<p>Displays "INVALID RECIPE FLAVOR(S) NOT INSTALLED OR FLAVOR(S) EXPIRED OR SLOT NEEDS CLEANING FLAVOR X"</p>	<p>See "Procedure to Install a Product Bag" on page 87.</p>
<p>Drink Dispense</p> 	<p>"WARNING ZONE 2 CLEANING DUE IN XX HOURS XX MINUTES"</p>	<p>Cleaning Warning</p>	<p>Within 8 hours of lockout.</p>	<p>Displays "WARNING ZONE 2 CLEANING DUE IN XX HOURS XX MINUTES"</p>	<p>See Installation, Operation and Maintenance manual.</p>
<p>Drink Dispense</p> 	<p>"ERROR! ZONE 2 CLEANING EXPIRED"</p>	<p>Clean Timer Expired</p>	<p>Zone 2 cleaning must be performed.</p>	<p>Displays "ERROR! ZONE 2 CLEANING EXPIRED"</p>	<p>See Installation, Operation and Maintenance manual.</p>
<p>Drink Dispense</p> 	<p>DISPENSER ERROR</p>	<p>System Relay Board out of sync. Communication lost between UI and SRB board</p>	<p>Possible power glitch and UI board reset while SRB in dispense state OR SRB reset and UI expects SRB to be in some other state.</p>	<p>DISPENSER ERROR</p>	<p>Turn OFF power switch for 10 seconds. Turn ON Call For service. Check connection onto SRB. See "SRB Board" on page 97. Check UI board connections. See "UI (User Interface - Touchscreen)" on page 95.</p>
<p>Drink Dispense</p> 	<p>"ERROR! LEFT MIXER" or "ERROR! RIGHT MIXER"</p>	<p>Mixer 1 or 2 out of sync</p>	<p>Possible power glitch and UI board reset while Mixer in dispense state OR SRB reset and UI expects Mixer to be in some other state.</p>	<p>"Blender in unexpected State" shall be displayed for the Left/right blender status message.</p>	<p>Turn off power switch for 10 seconds turn on. Check Blender board, and SRB firmware. Check DIP switches for proper position. See "Blender Control Board" on page 99.</p>
<p>Drink Dispense</p> 	<p>Service required, Please Contact your Local Multiplex Service Provider</p>	<p>Maintenance Required</p>	<p>1 year or 36,000 cycles have been reached.</p>	<p>Service required, Please Contact your Local Multiplex Service Provider is displayed.</p>	<p>Contact Manitowoc for proper procedure.</p>

CONTROL SYSTEM**Will Not Run Diagnostics****⚠ Warning**

High (line) voltage is present when the back and side panels are removed.

1. Verify primary voltage is supplied at the plug.
 2. Reboot by disconnecting and reconnecting the main power supply.
 3. Verify ON/OFF rocker switch functions properly and supplies line voltage to power relay coil (T1 - T0).
 4. Verify power relay contacts are closed (T2 -T4 and T6 - T8).
 5. Verify line voltage is present at the 24 VDC power supply primary - CN1.
 6. Verify 24 VDC is present at the power supply secondary - CN2.
 7. Verify in-line 4 amp fuse on 24 VDC supply is closed - CN2 T1.
 8. Verify 24 VDC is present at SRB board MTA2 (J1) connector. Disconnect and reconnect wiring to verify connection.
 9. Duct fan, cabinet refrigeration or ice machine operating?
 - No - Replace SRB board.
 - Yes - Go to next step.
 10. User Interface (UI) energized?
 - No - Inspect wiring, disconnect and reconnect wiring to verify connection, replace UI.
 - Yes - Go to next step.
 11. Does UI progress through screens?
 - No - Reload Firmware and Recipe File
See *"Firmware Update Procedure"* on page 80.
 - Yes - Go to next step.
 12. Do any components energize during the drink making sequence?
 - No - Replace SRB board.
 - Yes - Troubleshoot non functional component. If blender is non functional proceed to Blender Motor section.
 13. 24 VDC on Motor Controller Board MTA2 (J1)?
 - No - Replace wire.
 - Yes - Go to next step.
 14. Home position switch closed on motor controller circuit board Home SWT (J13)?
 15. Door switch circuit closed on motor controller circuit board Door SWT (J9)?
 16. Door switch circuit closed and supplying 24 VDC to coil on DPDT relay?
 17. Blade DPDT relay contacts closed?
 18. AC voltage present at J5, J6 of Motor Controller Board?
 - No – Voltage present at J15, J16 (Left Motor) J11, J12 (Right Motor) on the SRB?
 - No – Check wiring
 - Yes – Go to next step
- NOTE: Motor can be tested either in the Service Menu under the OUTPUTS Right Blade or Left Blade selection (See *"Service Screens"* on page 83) or within the Drink Menu selection Blend Only option (See *"Drink Selection Screen"* on page 67). Testing the motor in the Service Menu will provide half voltage for 3 seconds to the motor. Testing the motor in the Make Drink Menu should provide full voltage to the motor for a longer period of time determined by the recipe file.
19. When called for activation as mentioned in above note is AC voltage present at J2, J7 of the Motor Control Board?
 - No – Replace Motor Control Board
 - Yes- Go to next step
 20. Blade motor running?
 - No - Test capacitor - Replace blade motor.
 - Yes - Go to next step.
 21. Step motor operates?
 - No - Replace motor.

NOTE: Both blender assemblies will require testing.

BEVERAGE SYSTEM

Beverage System Diagnostics

1. Is line voltage is supplied?
2. Is Air/CO₂ supply pressure is between 70 and 80 psi and regulated to 35 psi? See "How to Check Air/CO2 Pressure" on page 46.
3. Is water supply pressure is between 30 and 90 psi and regulated to 35 psi?
4. Is product inserted in the cabinet and correctly connected to the product to pump fitting?
5. Is ice is available?
6. Has a recipe has been developed in MenuConnect and transferred to the control board with a USB drive? See "Recipe Loading Procedure" on page 81.
7. Do any recipes dispense properly?
 - No - See "Will Not Run Diagnostics" on page 35
 - Yes - Determine malfunctioning recipe slot number and continue with next step.

NOTE: See "Procedure to Clear Blocked Line" on page 36 to initiate a prime procedure and assure the component is energized during the test time period.

8. 24 VDC to syrup solenoid valve?
 - No - Inspect wiring, disconnect and reconnect wiring to verify connection, replace SRB board.
 - Yes - Go to next step.
9. Air/CO₂ supplied to product pump?
 - No - Replace syrup solenoid valve.
 - Yes - See "Procedure to Clear Blocked Line" on page 36. If the line is not blocked and the pump does not function, replace the product pump.

Procedure to Clear Blocked Line

NOTE: Verify product is available and properly connected before performing this procedure.

1. Fill a squirt bottle with very warm water.
2. Remove product bin.
3. Connect squirt bottle with vinyl tubing to product tube inlet.
4. Select the Inventory icon from the Main Menu.

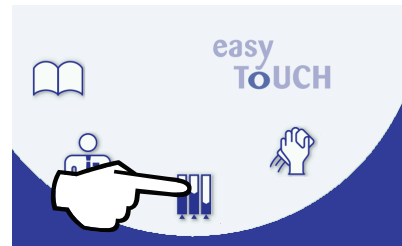

5. Select the product with the blocked line.

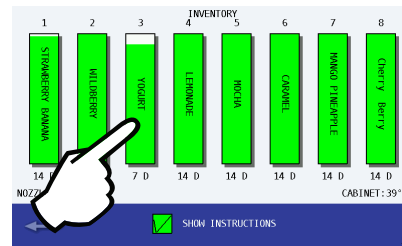

6. Select the green check twice without following the product replacement instructions.

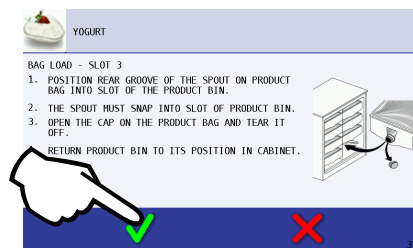

7. Select PRIME FLAVOR.

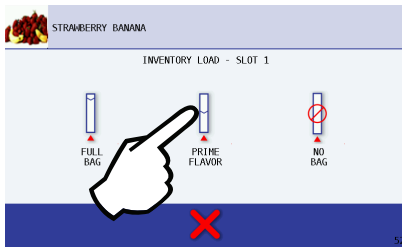

- 8. Place a cup under dispenser.
- 9. Select HOLD TO PRIME icon while squeezing the squirt bottle. Watch for product to enter the cup.

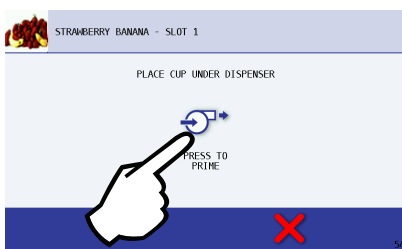

- 10. Repeat until valve clears, product and/or water enters the cup.
- 11. Disconnect squirt bottle with vinyl tubing. Insert product bin back into unit.
- 12. Select HOLD TO PRIME icon until only product flows into cup.
- 13. Press the Green Check when finished to return to the product Inventory screen.

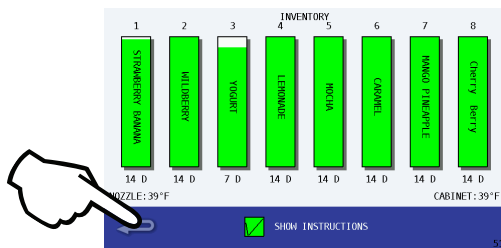

- 14. Press the Back Arrow to return to the Main Menu.

WATER SYSTEM CHECKLIST

A water-related problem could cause component misdiagnoses. Water system problems must be identified and eliminated prior to replacing other components.

Possible Problem List	Corrective Action List
Water supply pressure not between 65 and 90 psig.	Check water supply pressure & regulator Settings. <i>See "Supply to the Unit" on page 13</i>
Water regulator(s) on the unit should be set to 35psig dynamic.	Check regulator setting and adjust to 35 psig pressure. <i>See "How to Adjust Air/CO2 Pressure" on page 47</i>
Incoming water temperature is not between 45°F (1.7°C) and 90°F(4 C/ 32.2°C)	If too hot, check the hot water line check valves in other store equipment.
Water filtration is plugged (if used)	Install a new water filter.
Hoses, fittings, etc., are leaking water.	Repair/replace as needed.
Ice Chute safety switches stuck open or closed	Clean/replace if needed.

BLENDER CONTROLS FLOWCHART

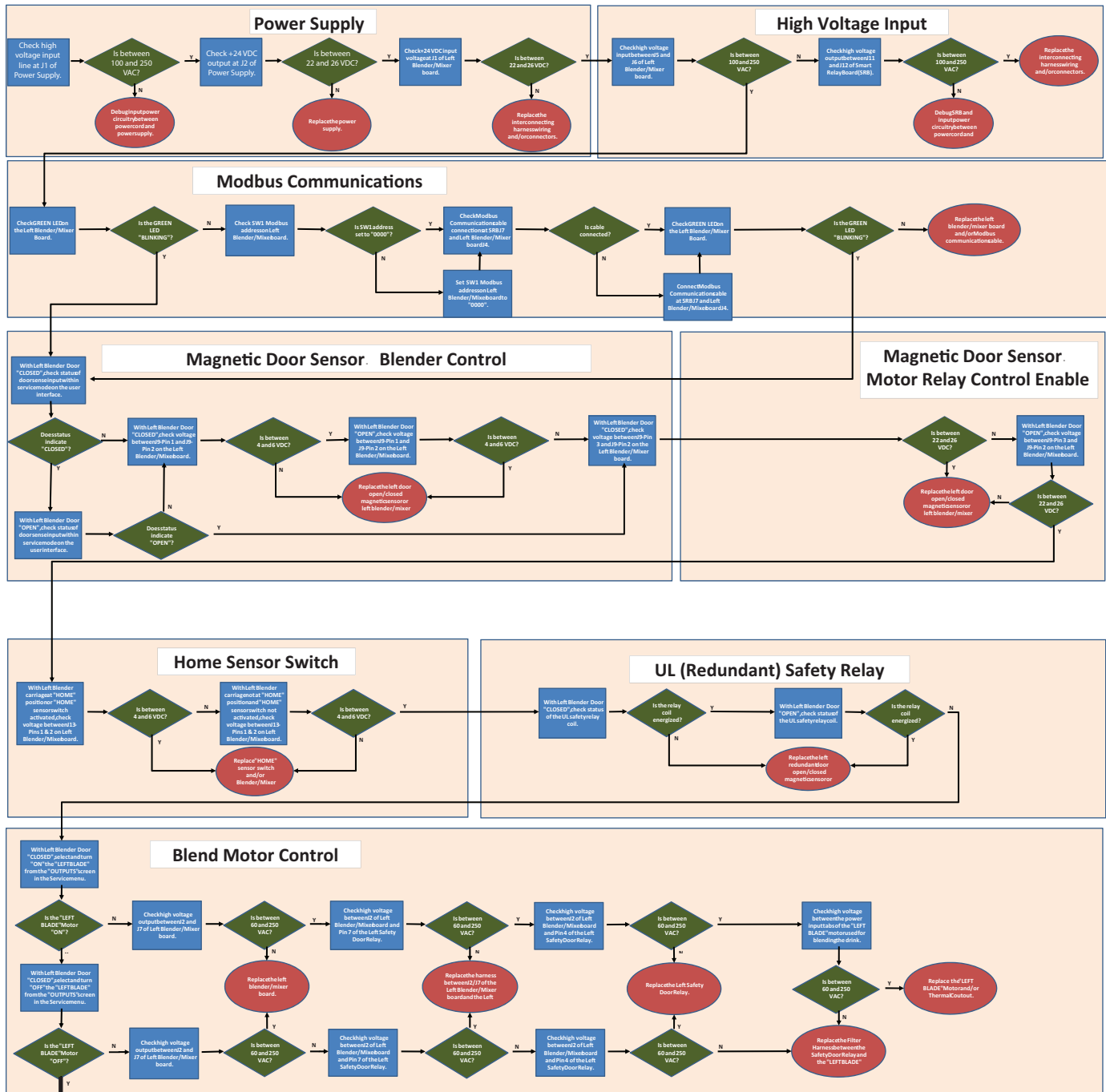

Continue to Solenoid Valve Control page 39

Refrigerated Cabinet

REFRIGERATED CABINET FLOWCHART

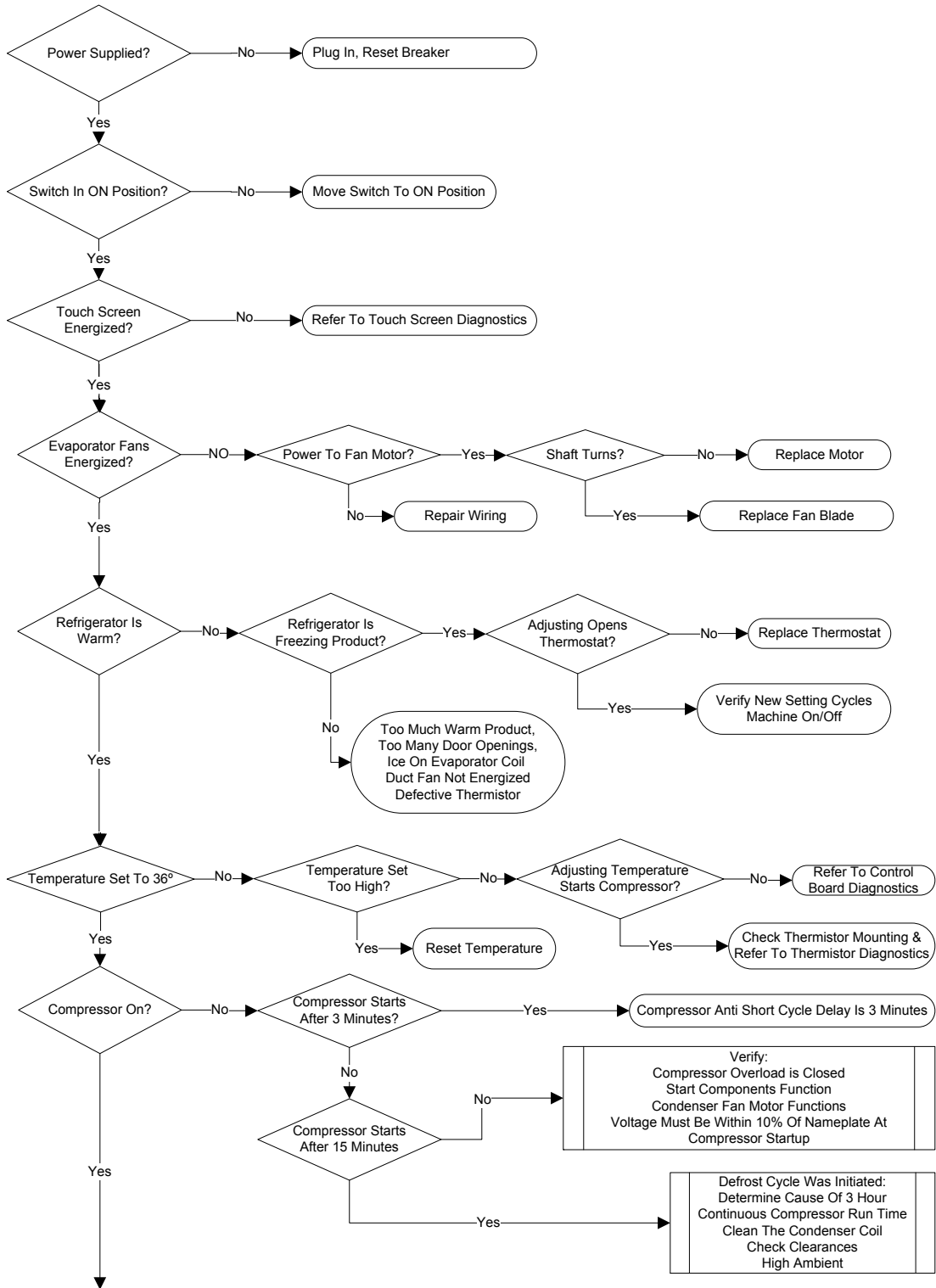

REFRIGERATED CABINET FLOWCHART (CONTINUED)

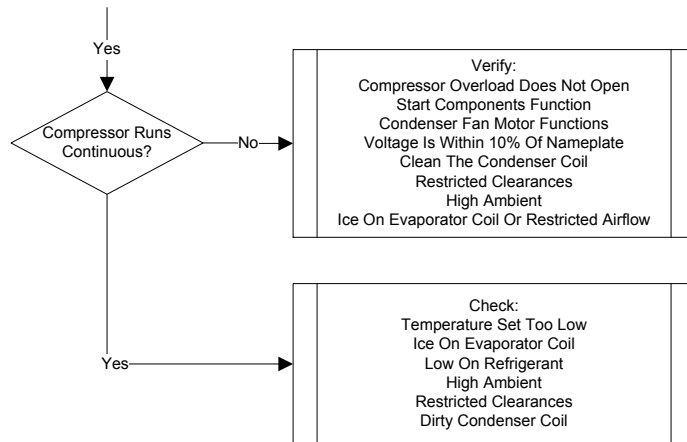

REACH-IN TEMPERATURE OUT OF RANGE

Check Refrigeration System & Door Seal

Temperature in reach-in unit above or below acceptable limits.

Above temperature limit:

- Verify Cabinet temperature is above 5.5°C/42°F.
- Compare temps on UI (User Interface).
- Check duct fan (1) for proper operation.
- Check evaporator fans (3) for proper operation.

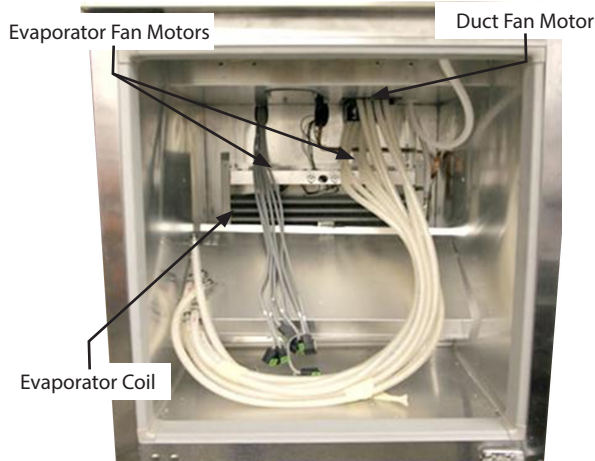

- Verify door is closed and door gasket is in place.
- If all above are within Spec's refer to Refrigeration diagnostics. See "Refrigeration System Diagnostics" on page 44.

Below temperature limit:

- Compare temps on UI (User Interface).
- Check temperature set point.
- Using the touch screen, go to the Managers Menu on the Main Screen, click on the Managers Icon.



- Type in password (default is "A") and press the green check mark.

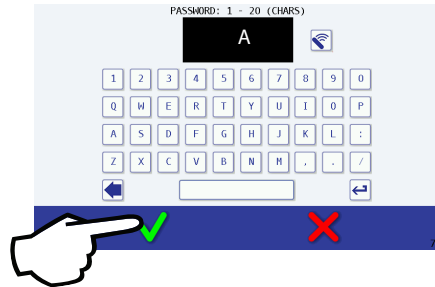

- Select the down arrow.

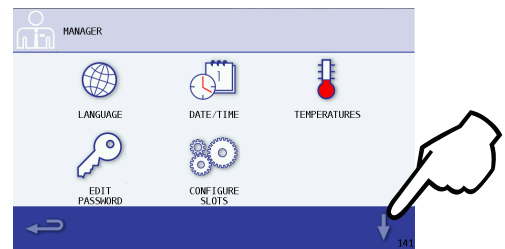

- Select the Service icon.

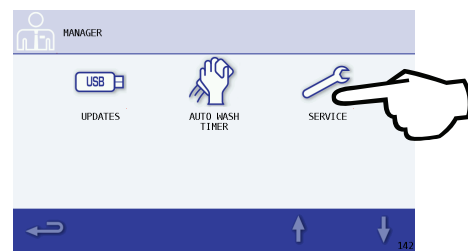

- Type in password (default is "A") and press the green check mark.

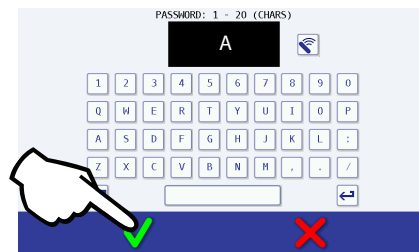

- Select the down arrow.

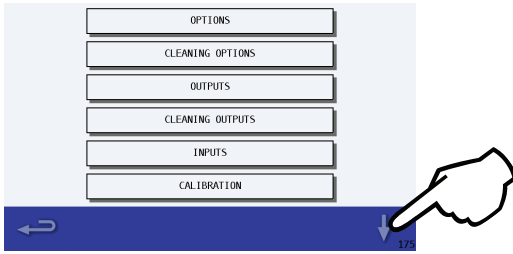

- Select CABINET SETTINGS.

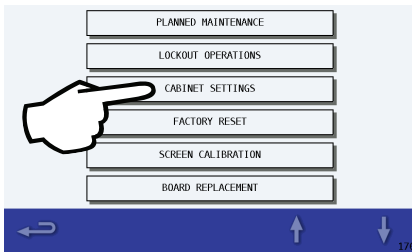

- Read temperatures.

CABINET SETTINGS		
SETTING	VALUE	UNITS
SET POINT	36.0	°F
DIFFERENTIAL	4.0	°F
MIN OFF TIME	3	MINUTES
DEFROST RUN TIME	180	MINUTES
DEFROST TEMPERATURE	43.0	°F
DEFROST TIME	15	MINUTES
DEFROST INITIAL TEMPERATURE	5.0	°F
DEFAULT ON TIME	12	MINUTES

Check Thermistor

SPECIFICATIONS

- 5,000 Ohms ± 2% at 25°C (77°F)
- 16,330 Ohms ± 2% at 0°C (32°F)

CHECK PROCEDURE

NOTE: Use a multimeter to check operation.

1. Reboot machine by moving rocker switch OFF/ON.
2. Inspect for correct wiring.
3. Isolate by disconnecting the wiring connectors on SRB J32 Temp Drive 3 / Cabinet Probe 1.
4. Check continuity across the terminals with an ohm meter.
 - Resistance = Thermistor is good
 - Open (OL) = Replace thermistor

NOTE: These thermistors are identical. Swapping the thermistor connections at the IO board can be used for diagnostics. See "Temperature/Resistance Chart" on page 107.

Check compressor relay on SRB

With power disconnected, check the compressor relay that is mounted on the SRB. The compressor relay is the largest relay on the SRB and has two terminals exposed that can be checked for continuity. The exposed terminals are the Common (C) and the Normally Open (NO). If there is continuity between the terminals with power disconnected to the unit, the relay contacts are defective and the SRB should be replaced.

HIGH PRODUCT TEMPERATURE

Check Duct Cooling Fan

- Product temperature is greater than 42°F.
- Verify the door was not left open or warm product was added.
- Reboot machine by moving toggle switch off/on.
- Verify duct fan is operating.
- Allow machine to run for 15 minutes then prime each product.
- If fault remains check duct temperature with a digital thermometer to determine if refrigeration or thermistor diagnostics need to be performed.

Refrigeration System Diagnostics

ANALYZING DISCHARGE PRESSURE OR TEMPERATURE

1. Determine the ice machine operating conditions:
 - Air temperature entering condenser
 - Air temperature around ice machine
 - Water temperature entering water reservoir
2. Refer to 24-Hour Ice Production/Refrigeration Pressure/Temperature Chart for ice machine being checked.

Use the operating conditions determined in step 1 to find the published normal discharge pressure/temperature and compare to actual measurements.

3. Measure the actual discharge pressure/temperature.
4. Compare the measurements (step 3) with the published pressure/temperature (step 2).

Measurements will fall within the published range on normally operating ice machines.

Discharge Pressure/Temperature High Checklist

Problem	Cause
Improper installation	Refer to Installation procedures.
Restricted condenser air flow	Dirty air filter High inlet air temperature Condenser discharge air recirculation Dirty condenser fins Defective fan motor Defective fan cycle control
Improper refrigerant charge	Overcharged Non-condensable in system Wrong type of refrigerant
Other	Non-OEM components in system High side refrigerant line/component restricted (before mid-condenser)

Discharge Pressure/Temperature Low Checklist

Problem	Cause
Improper installation	Refer to Installation procedures.
Improper refrigerant charge	Undercharged Wrong type of refrigerant
Other	Low ambient temperature High side refrigerant lines/component restricted (before mid-condenser) Suction pressure is too low and affecting discharge pressure. (Refer to "Suction Pressure/Temperature Low Checklist.") No water or insufficient pressure Starving expansion valve Defective compressor Moisture in refrigeration system Defective fan cycle control

NOTE: Do not limit your diagnosis to only the items listed in the checklists.

ANALYZING SUCTION PRESSURE OR TEMPERATURE

NOTE: Analyze discharge pressure/temperature before analyzing suction pressure/temperature. High or low discharge pressure/temperature may be causing high or low suction pressure/temperature.

Suction Pressure/Temperature High Checklist

Problem	Cause
Improper installation	Refer to Installation procedures.
Discharge pressure	Discharge pressure/temperature is too high and is affecting suction pressure/temperature. Refer to "Discharge Pressure/Temperature High Checklist."
Improper refrigerant charge	Overcharged Wrong type of refrigerant Non condensable in system
Other	Non-OEM components in system TXV flooding (check bulb mounting and insulation). Defective compressor

Suction Pressure/Temperature Low Checklist

Problem	Cause
Improper installation	Refer to Installation procedures.
Discharge pressure/temperature	Discharge pressure/temperature is too low and is affecting suction pressure/temperature. Refer to "Discharge Pressure/Temperature Low Checklist."
Improper refrigerant charge	Undercharged. Wrong type of refrigerant.
Other	Non-Manitowoc components in system. Restricted/plugged liquid line drier. Restricted/plugged tubing in suction side of refrigeration system. Expansion valve starving. No water or insufficient pressure. Moisture in refrigeration system. Dirty evaporator. Defective fan cycle control.

NOTE: Do not limit your diagnosis to only the items listed in the checklists.

Procedure to Clear Blocked Line

NOTE: Verify product is available and properly connected before performing this procedure.

1. Fill a squirt bottle with very warm water.
2. Remove product bin.
3. Connect squirt bottle with vinyl tubing to product tube inlet.
4. Select the Inventory icon from the Main Menu.



5. Select the product with the blocked line.

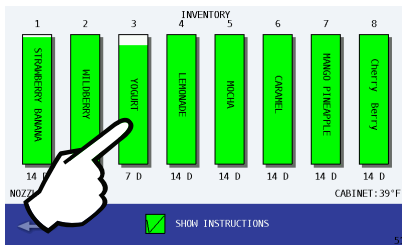

6. Select the green check twice without following the product replacement instructions.

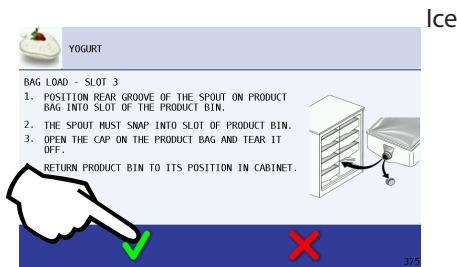

Chute safety switches stuck open or closed

7. Select PRIME FLAVOR.

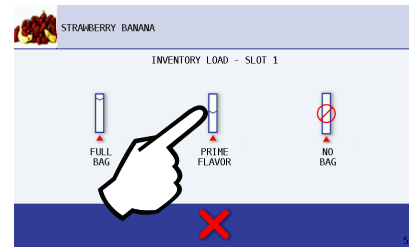

8. Place a cup under dispenser.
9. Select HOLD TO PRIME icon while squeezing the squirt bottle. Watch for product to enter the cup.

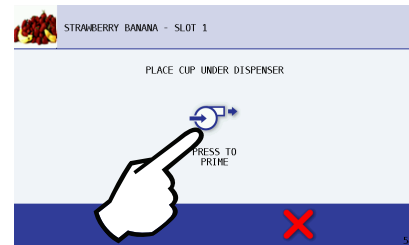

10. Repeat until valve clears, product and/or water enters the cup.
11. Disconnect squirt bottle with vinyl tubing. Insert product bin back into unit.
12. Select HOLD TO PRIME icon until only product flows into cup.
13. Press the Green Check when finished to return to the product Inventory screen.

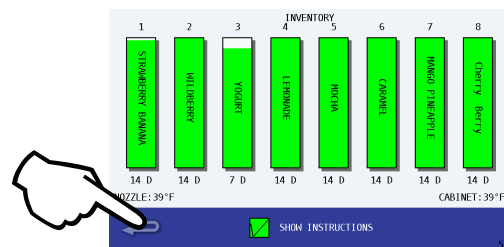

14. Press the Back Arrow to return to the Main Menu.

How to Check Air/CO₂ Pressure

- Using the touch screen, go to the Prime Screen, which is accessed through the Inventory icon from the Main Menu.



- On the inventory screen select any assigned product slot.

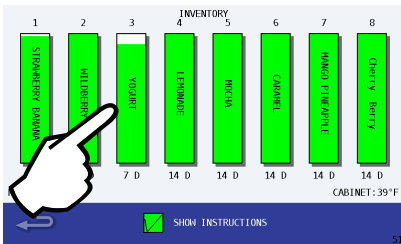

- Select the Green Check twice without following the product replacement instructions.

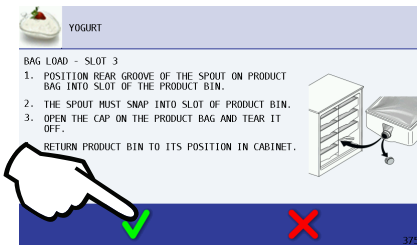

- Select the PRIME FLAVOR icon.

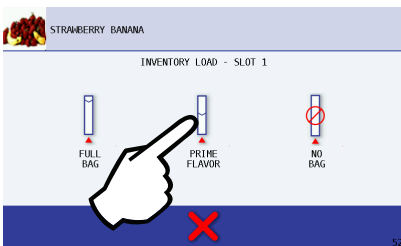

- Place a cup under dispenser.

- Locate the Air/CO₂ regulators on the unit. See "Regulator Settings & Location" on page 14.

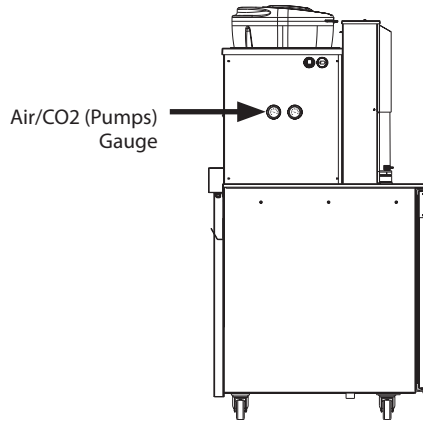

- Press and hold the HOLD TO PRIME icon while checking the CO₂ pressure reading on the regulator on the left side of the unit.

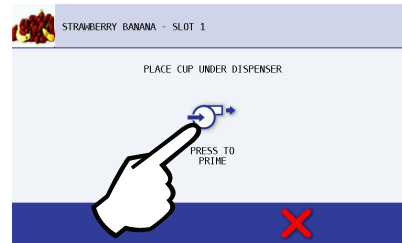

- The regulator will decrease to a stable pressure while the product is priming and then rise back to a higher pressure when the prime button is released.

35 psi
 (.24 MPa, 241 kPa, 2.41 bar)
 +/- 2 psi (.014 MPa, 14 kPa, .14 bar)



- The regulator should maintain 35 psi (0.24 MPa, 241 kPa, 2.41 bar) +/- 2 psi (.014 MPa, 14 kPa, .14 bar) under flowing conditions.
- If the Air/CO₂ regulator fails to maintain this pressure during flowing conditions, adjust. (See "How to Adjust Air/CO₂ Pressure" on page 47)

NOTE: To save product, Air/CO₂ pressure can be checked during Zone 2 Cleaning or at any time product pumps are in use.

HOW TO ADJUST AIR/CO₂ PRESSURE

- Using the touch screen, go to the Managers Menu on the Main Screen. Click on the Managers Icon.

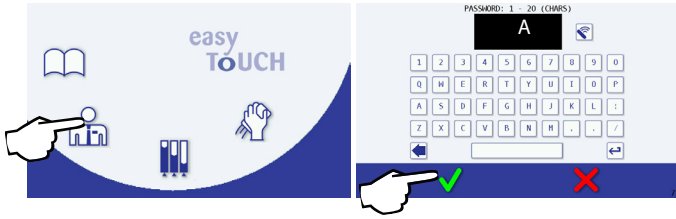

- Type in password (Default password is "A") and click the green check mark.
- Select the down arrow.

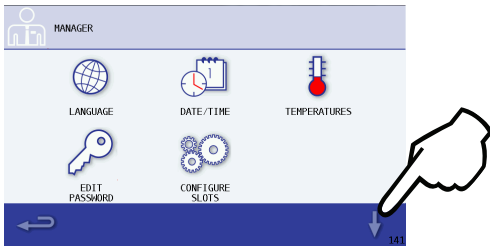

- Select the Service icon.

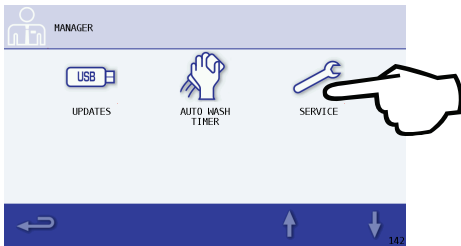

- Type in password (Default password is "A") and click the green check mark.

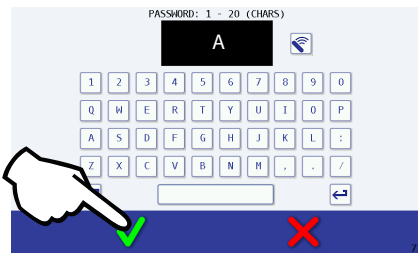

- Select OUTPUTS.

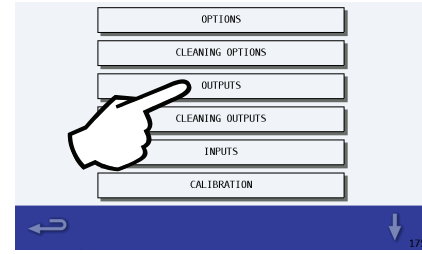

- First check in refrigerated cabinet to confirm an open slot. Identify the open slot number (FLAVOR SOLENOID #x) on the screen.

COMPONENT	CURRENT STATE
FLAVOR SOLENOID 1:	OFF
FLAVOR SOLENOID 2:	OFF
FLAVOR SOLENOID 3:	OFF
FLAVOR SOLENOID 4:	OFF
FLAVOR SOLENOID 5:	OFF
FLAVOR SOLENOID 6:	OFF
FLAVOR SOLENOID 7:	OFF
FLAVOR SOLENOID 8:	OFF

- Locate the Air/CO₂ regulators on the unit. See "Regulator Settings & Location" on page 14.

- In the green box select the Flavor Solenoid previously identified.

COMPONENT	CURRENT STATE
FLAVOR SOLENOID 1:	OFF
FLAVOR SOLENOID 2:	OFF
FLAVOR SOLENOID 3:	OFF
FLAVOR SOLENOID 4:	OFF
FLAVOR SOLENOID 5:	OFF
FLAVOR SOLENOID 6:	OFF
FLAVOR SOLENOID 7:	OFF
FLAVOR SOLENOID 8:	ON

- The regulator will decrease to a stable pressure while the product is priming and then rise back to a higher pressure when the prime button is released.

35 psi
 (.24 MPa, 241 kPa, 2.41 bar)
 +/- 2 psi (.014 MPa, 14 kPa, .14 bar)

- The regulator should maintain 35 psi (.24 MPa, 241 kPa, 2.41 bar) +/- 2 psi (.014 MPa, 14 kPa, .14 bar) under flowing conditions.

- If the Air/CO₂ regulator fails to maintain this pressure during flowing conditions, remove panels and adjust under flowing conditions.

How to Check Plain Water Pressure

- Using the touch screen, gain access to the Blend Chamber Rinse Button(s) located at the bottom of either the Drink or Flavor Selection screen.

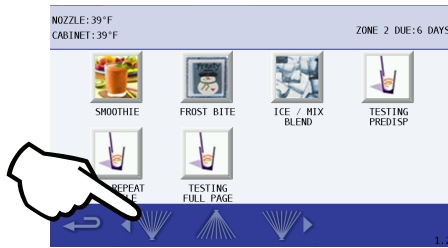

35 psi
 (.24 MPa, 241 kPa, 2.41 bar)
 +/- 2 psi (.014 MPa, 14 kPa, .14 bar)



- If the plain water regulator fails to maintain this pressure during flowing conditions, adjust.

- Activate a rinse cycle by touching the right or left rinse button while reading the Plain Water regulator on the unit. See "Regulator Settings & Location" on page 14.

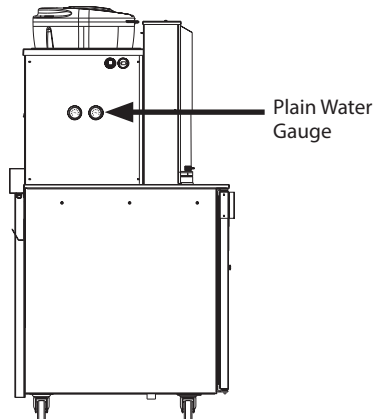

- The regulator will decrease to a stable pressure while the water is flowing and then rise back to a higher pressure once the rinse completes.
- The Plain Water regulator should maintain 35 psi (0.24 MPa, 241 kPa, 2.41 bar) +/- 2 psi (.014 MPa, 14 kPa, .14 bar) under flowing conditions.

Section 6 Controls

Touch Screens

The “easy ToUCH” screen has four selections. One is for the drink making procedure: Drink Selection displays by default at start-up. The Manager’s Menu is for accessing the machine’s settings. Inventory is for product information and Cleaning is for routine maintenance of the machine.

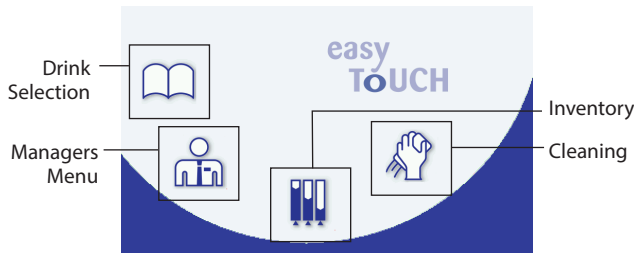

Main Menu Screen

Drink Selection

- See “Drink Selection Screen”
- See “Flavor Selection Screen” on page 50.
- See “Size Screen” on page 50.
- See “Main Menu Screen” on page 52.

Manager’s Menu

- See “Main Menu Screen” on page 52.
- See “Manager’s Menu Screen” on page 53.

Inventory

- See “Main Menu Screen” on page 52.
- See “Product Inventory Screen” on page 68.

Cleaning

- See “Main Menu Screen” on page 52.
- See “Cleaning Screen” on page 70.

DRINK SELECTION SCREEN

The Drink Selection screen appears on power-up (except where clean/sanitize limitations have been exceeded, in which case the Cleaning screen appears). See Maintenance for Daily and Weekly cleaning/sanitization. This screen’s primary function is to select a drink to make or access the Main Menu.

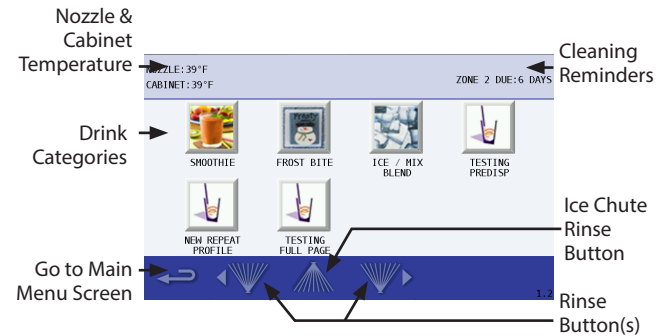

How to Access

The Drink Selection screen displays by default unless cleaning is required. This screen can also be accessed through the Main Menu Book Icon.

Icon Button Descriptions

- **NOZZLE & CABINET Temperatures**
Displays the current temperature for dispense point nozzle and the refrigeration cabinet. Unit of measure can be changed in the Manager’s Menu.
 - **Drink Categories**
The main product categories are displayed left to right on the Drink Selection screen. Touching a category will display the drink flavor options available for the category.
- NOTE: Available drink selections may vary depending on the recipe file installed.
- **Main Menu Arrow**
Navigates to the Main Menu screen.
 - **Cleaning Reminders**
Displays the time remaining in days until ZONE 2 (Weekly) and ZONE 3* (Monthly) cleaning is required. **If equipped with this feature.*
 - **Rinse Button**
Press to rinse the left or right blender chambers. Blend chamber door(s) must be closed.
 - **Ice Chute Rinse Button**
Press this button to rinse the ice chute if it becomes clogged. Repeat if necessary.

FLAVOR SELECTION SCREEN

The Flavor Selection screen appears after a Drink Selection has been made. Flavor options will vary depending on what recipes are configured on the unit. This screen's primary function is to select a drink flavor.

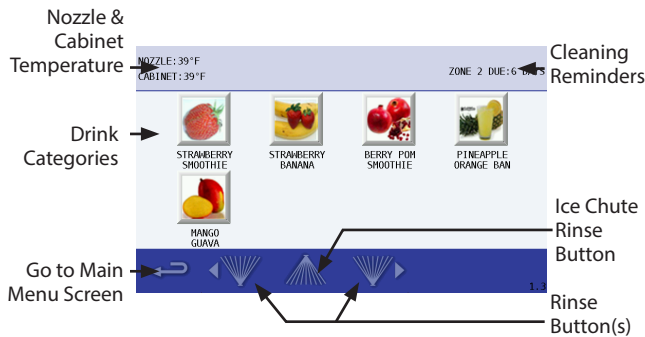

How to Access

The Flavor Selection screen displays after a drink selection has been made from the Drink Selection screen.

Icon Button Descriptions

- **NOZZLE & CABINET Temperatures**
Displays the current temperature for dispense point nozzle and the refrigeration cabinet. Unit of measure can be changed in the Manager's Menu.
- **Drink Flavor Buttons**
Flavor choices for the drink type that was selected.
 - **Yellow Border**
If any of the drink ingredients will expire soon, the yogurt has expired, or there is less than 10% left in the product bag. Check the Product Inventory Screen for exact amount of product remaining.
 - **Red Border**
Product expired or product bag empty, flavor selection unavailable. Will need to replace product bag.

NOTE: Available flavor selections may vary depending on the recipe file installed.

- **Back Arrow**
Navigates to previous Drink Selection screen.
- **Cleaning Reminders**
Displays the time remaining in days until ZONE 2 (Weekly) and ZONE 3* (Monthly) cleaning is required. **If equipped with this feature.*
- **Rinse Button**
Press to rinse the left or right blender chambers. Blend chamber door(s) must be closed.
- **Ice Chute Rinse Button**
Press this button to rinse the ice chute if it becomes clogged. Repeat if necessary

SIZE SCREEN

The Size screen appears after a drink flavor has been chosen from the Flavor Selection Screen. This screen's primary function is to select size and make a drink. Optional Add-Ins are also performed through this screen if the drink requires them.

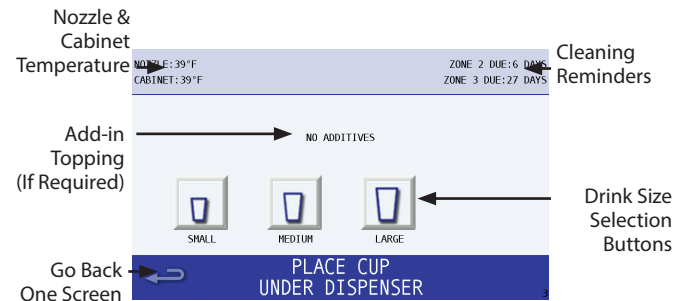

How to Access

The Size Selection screen displays after a flavor selection has been made from the Flavor Selection screen.

Icon Button Descriptions

- **NOZZLE & CABINET Temperatures**
Displays the current temperature for dispense point nozzle and the refrigeration cabinet. Unit of measure can be changed in the Manager's Menu.
- **Add-Ins**
These are not functioning buttons, only a graphic representation of the add-in used when making the selected drink. The screen will prompt the user when the add-in is to be added to the drink.
- **Drink Size Buttons**
Press a drink size (SMALL, MEDIUM, or LARGE) to start the drink making process.

NOTE: Not all drinks have an add-in. Drink add-ins may vary depending on the recipe file installed.

NOTE: Make sure the correct cup is in place before pressing the drink size button, once one is selected the unit will start dispensing product and the screen will display "DISPENSING".

The screen will prompt to place cup in mixer when dispensing is complete and return to the Drink Selection screen while blending the drink. (See "Procedure to Make a Drink" on page 24)

- **Back Arrow**
Navigates to previous Flavor Selection screen.
- **Cleaning Reminders**
Displays the time remaining in days until ZONE 2 (Weekly) and ZONE 3* (Monthly) cleaning is required. **If equipped with this feature.*

Procedure to Make a Drink

NOTE: Ice must be present in the ice hopper, product must be connected and primed to produce a drink.

1. Press the Open Book icon.



2. Select a category of drink recipes.

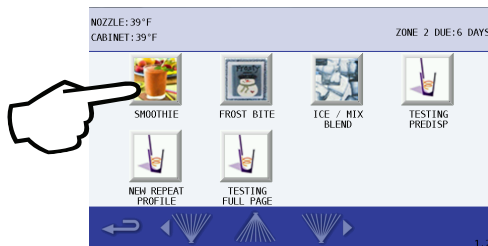

3. Specific drink combinations are displayed on the next screen. If a drink is not available, it will be highlighted with a red square around it. Unavailable flavors have expired and will need to be replaced. (See "Procedure to Install a Product Bag" on page 32)



4. Drink size is the next selection.

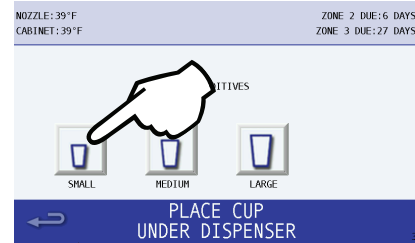

5. Place cup under center dispenser and press the corresponding drink size (SMALL, MEDIUM, or LARGE) to start the drink making process.

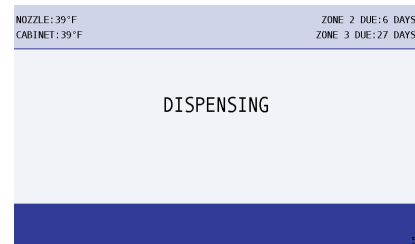

6. As the flavor dispenses into the cup, the screen will display DISPENSING.
7. If Add-in ingredients need to be manually added, the screen will give specific directions. More ingredients may be required later, follow the screen directions.



8. The screen will prompt you to use an available mixer, place the cup into the blender chamber, and shut the door. Press the corresponding right or left flashing green/blue arrow to mix the drink.

NOTE: Single mixer unit will only display a right arrow. Press the red X to cancel.

- While the drink is mixing, the top of the screen will read **BLENDING**

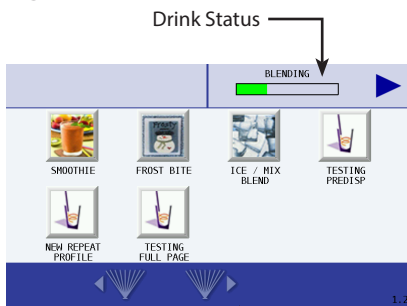

NOTE: On dual mixer units, a second drink can be selected and blended simultaneously.

- Follow all drink specific screen directions for add-ins if necessary and press the flashing arrow if prompted.

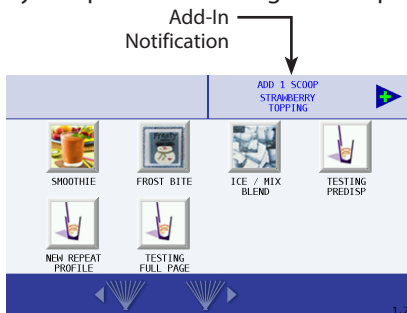

- When the blender is done mixing, open the door and remove the drink. The blending station will go through a rinse cycle after the door is closed again.

NOTE: The blend station will not be available again until the door is closed and the rinse cycle is completed.

MAIN MENU SCREEN

Accessed primarily through the Drink Selection screen, this screen's primary function is to provide access to all other procedures and adjustments that can be performed on the unit.



How to Access

Normally accessed through the return arrow in the bottom left of the Drink Selection screen.

Category Icon Descriptions

- Drink Recipes Menu**
 Displays the Drink Selection screen.
- Managers Menu**
 Displays a Password Keypad screen. When password is correctly entered, a menu of protected information for a manager will display.
- Inventory**
 Displays the remaining percentage of product in each bag, and NOZZLE and CABINET temperature readings.
- Cleaning**
 Displays the Cleaning screen and gives the options for ZONE 1 (Daily), ZONE 2 (Weekly) cleaning, and PRODUCT LINE FLUSH.

MANAGER'S MENU SCREEN

Accessed through the Main Menu screen, this screen's primary function is to provide on-screen access to Manager-only functions.

How to Access



After selecting Manager's Menu icon from the Main Menu, the password screen appears. The manager screens are password protected. (Default Password is "A.") Enter the Manager's pass code using the QWERTY keypad, then press the green check to accept.

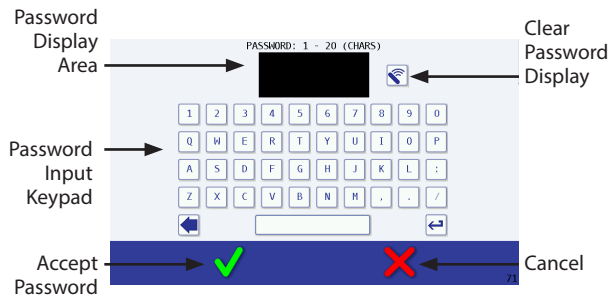

After typing in the correct password, Language, Date/Time, Temperatures, Edit Password, Configure Slots, Updates, Auto Wash Timer and Service screens are accessible. When the manager screens are inactive for a time period, the screen will return to the drink menu.

Important

Do not change the language, edit the password or configure the slots unless instructed to do so by the factory.

Manager Menu Features

• **Manager Screen 1**

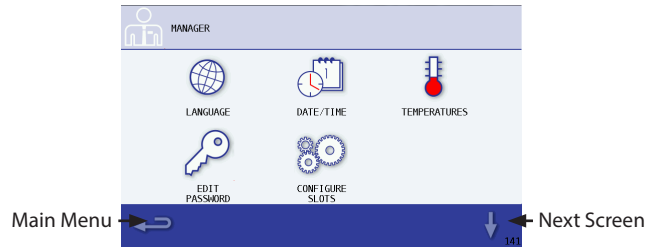

- LANGUAGE ("Changing the UI Language" on page 54)
- DATE & TIME Settings ("Date & Time Setting" on page 55)
- TEMPERATURE ("Temperature Setting" on page 56)
- EDIT PASSWORD ("Edit Password Setting" on page 56)
- CONFIGURE SLOTS ("Configure Slots Setting" on page 57)

• **Manager Screen 2**

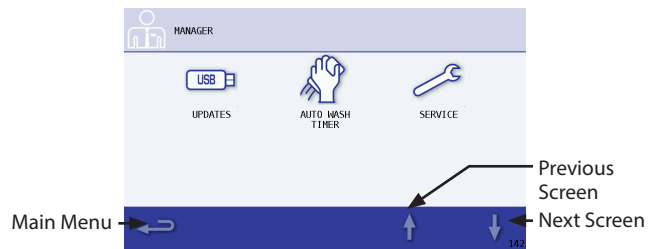

- UPDATES ("Updates" on page 61)
- AUTO WASH TIMER ("Auto Wash Timers" on page 65)
- SERVICE ("Service Screens" on page 65)

• **Manager Screen 3**

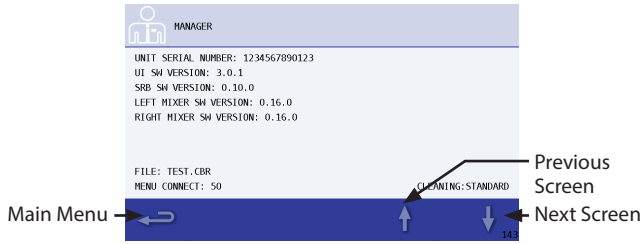

This screen displays all current software versions on the unit. (See “Software Version Screen” on page 67.)

• **Manager Screen 4**

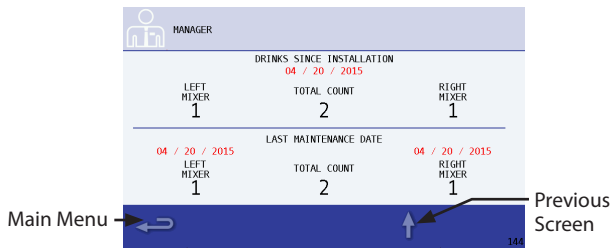

This screen displays the Mixer/Blend Cycle counter. Count is not incremented for non-blended drinks. (See “Drink Counter Screen” on page 67.)

Changing the UI Language

Important

Do not change the language unless instructed to do so by the factory.

These steps are to be followed once the user has gained access to the Manager’s Menu by entering the correct password (Default Password is “A”).

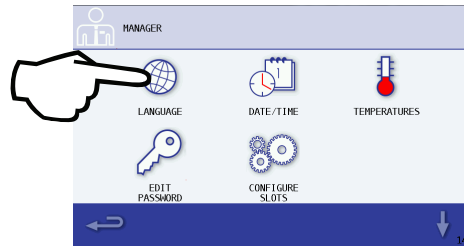

1. Select the LANGUAGE icon from the first Manager’s Menu screen.



2. Select a language. A green check box indicates what language is currently selected.

NOTE: Up to four (4) languages may be available, including English. Available languages are controlled by the recipe file and are configured in MenuConnect.

3. Press the return arrow in the lower left corner to save and return to the first Manager’s Menu screen.
4. Press the return arrow again to return to the Main Menu.

Date & Time Setting

Important

Set the correct date and time at installation. Correct the date or time when necessary.

These steps are to be followed once the user has gained access to the Manager’s Menu by entering the correct password (Default Password is “A”).

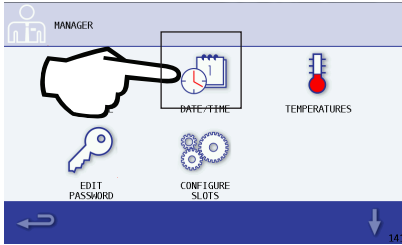

1. Select the DATE/TIME icon from the first Manager’s Menu screen.

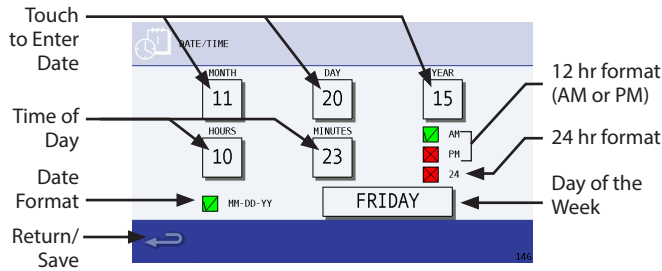

- Choose the date format that will be used on the machine: MM-DD-YY.
- To enter the Month, Day, Year, Hours, or Minutes, touch the corresponding box, type in the correct number, and press the green check to accept.
- If using 12 hr time format, select AM or PM. If using 24 hr format select the 24 check box.
- Only select the Installation check box if this will be the installation date/time.

2. Select the return/save arrow when done.

3. If changes were made, the following screen will display:

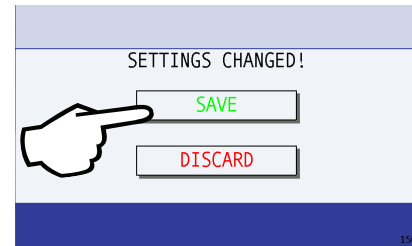

- Press SAVE to save the new settings.
- Press DISCARD to cancel any changes.
- The Manager’s Menu will appear after a selection has been made.

4. Press the return arrow again to return to the Main Menu.

Temperature Setting

These steps are to be followed once the user has gained access to the Manager's Menu by entering the correct password (Default Password is "A").

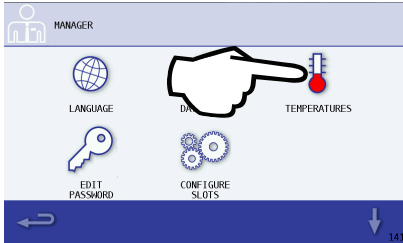

1. Select the TEMPERATURES icon from the first Manager's Menu screen.

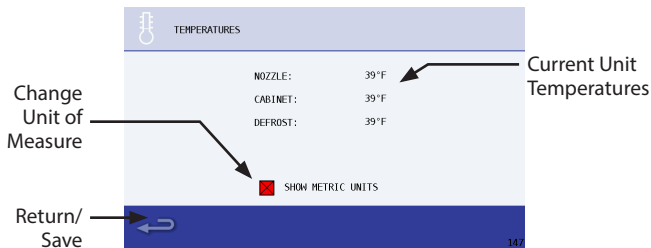

- The screen will display the current NOZZLE, CABINET, and DEFROST temperature readings.
- To change to Celsius/Metric Units of measure, press the check box next to SHOW METRIC UNITS. A green check box means Metric has been selected.
- Press the return arrow to return to the previous screen.

Edit Password Setting

Important

Only a trained manager or authorized technician should change the default password. Be sure to keep record of the new password.

These steps are to be followed once the user has gained access to the Manager's Menu by entering the correct password (Default Password is "A").

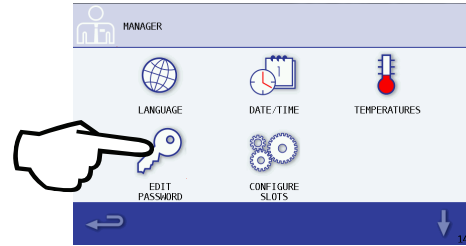

1. Select the EDIT PASSWORD icon from the first Manager's Menu screen.

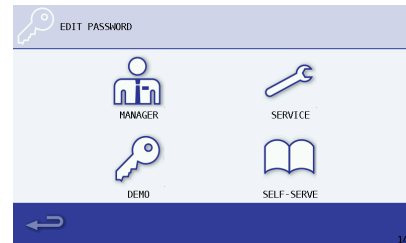

- Choose which password to change, MANAGER, SERVICE, DEMO, or SELF-SERVE.

NOTE: If changing all passwords, they each have to be selected and changed one at a time.

2. Enter the current password. "A" is the factory default for the "Manager" and/or "Service" password(s). "DEMO" is the factory default for Demo selection and "SELF" is the factory default for self-serve selection.

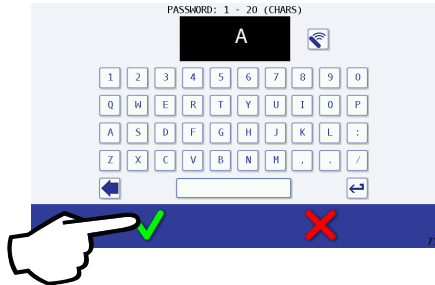

- Press the green check to continue.

3. Enter the new password, anything from 1-20 characters.
 - Press the green check to continue.
4. Confirm the new password by entering it again.
 - Press the green check to confirm and finish changing the password.
5. The Edit Password Screen will appear.

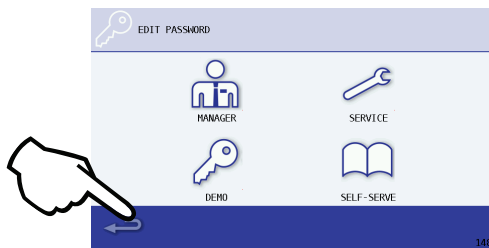

6. Press the return arrow twice to go back to the Main Menu.

Configure Slots Setting

These steps are to be followed once the user has gained access to the Manager's Menu by entering the correct password (Default Password is "A").

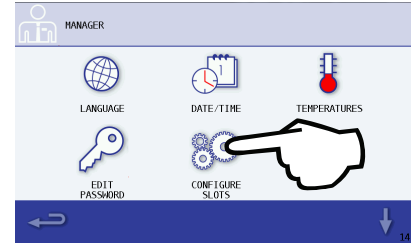

Select the Configure Slots icon from the first Manager's Menu screen. There are two sub-menus, SLOT FLAVOR and CALIBRATE FLAVOR.

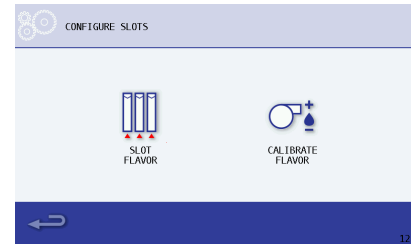

- The SLOT FLAVOR icon is used to assign flavors to each product slot on the machine.
- See "Assigning Flavors" on page 58.
- The CALIBRATE FLAVOR icon is used for calibration of each assigned flavor. Calibrate Flavor is a process to ensure the machine is dispensing the correct amount from each product slot, water and ice. See "Calibration Procedure" on page 59.

Assigning Flavors

1. Press the SLOT FLAVOR icon.

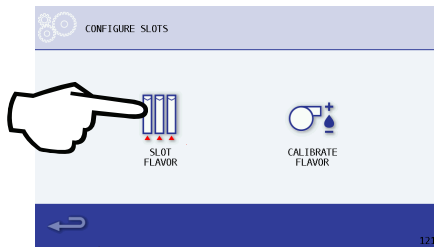

2. Select a slot you want to assign a flavor to.

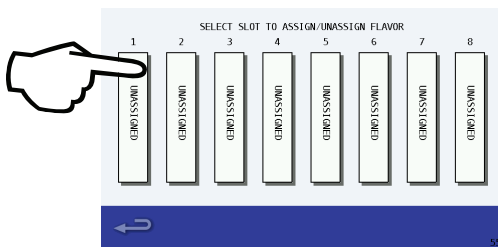

3. Select from available flavors.

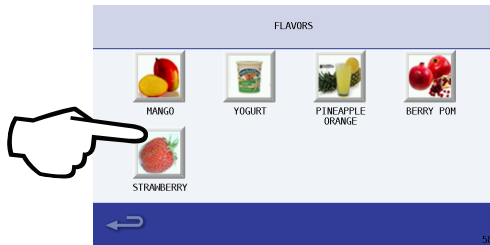

4. Continue to select slots and flavors until all slots are assigned.

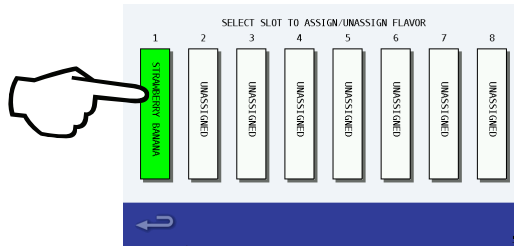

5. Select the red X when finished to return to the Configure Slots screen. Select the return arrow twice to return to the Main Menu.

NOTE: Available flavors will vary depending on the recipe file that is loaded on the machine. Select ASSIGN FLAVOR.



- Screen will return to the Slot Selection screen.
- The flavor name will now display and the slot will be highlighted green.

Calibration Procedure

Important: Pre-calibration Checklist

- If calibrating ice, go to the Drink Menu and dispense 4 large cups of ice prior to calibrating.
- Check for empty product bags in the cabinet and replace if necessary.
- Ensure that each flavor has a bag more than 1/3 full.
- Check bag to ensure the spout is securely locked in position and the spout side of bag is facing down.
- Ensure product flavors to be calibrated have been refrigerated for 24 hours in a 34°F/1°C – 40°F/4°C environment and the product cabinet is at operating temperature 32°F/0°C – 34°F/1°C.
- Check Zone 2 cleaning was completed over 1 hour ago.
- Check CO₂/air pressure. If CO₂/Air pressure has changed, reset pressure to required level.
- Check that Machine has been turned on for at least 1 hour – Do not proceed with this check during peak time - Dispense 2 large cups of ice.

Gather the following supplies

Digital Scale	
Empty & Clean Cups	

NOTE: Except for Water and Ice, a flavor must first be assigned and product bag loaded before a slot can be calibrated.

- From the Main Menu, select the Manager icon.



- Enter the manager's password.
- Select CONFIGURE SLOTS.

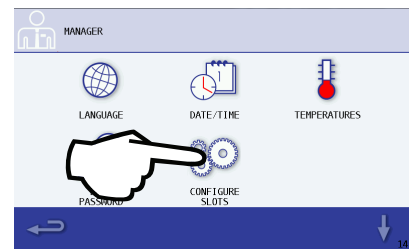

- Select CALIBRATE FLAVOR.

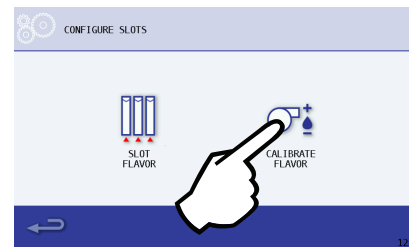

- Select a flavor, water or ice to calibrate.

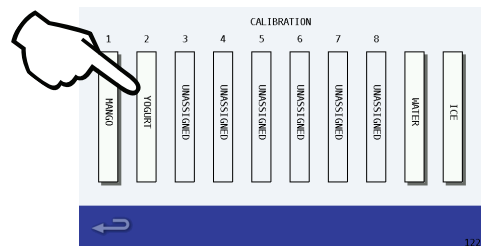

Selectable Flavors will have a drop shadow

NOTE: If a flavor cannot be selected the bag loading procedure must first be performed (See "Procedure to Install a Product Bag" on page 69).

6. Follow the on-screen instructions and do the following:

- Get a digital scale.
- Tare empty cup weight.
- Position an empty cup for dispense.

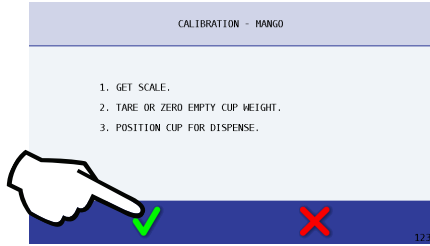

• Press Green Check when ready.

- A. Wait until dispensing is done.
- B. Weigh cup.
- C. Flavor and water target is 4 oz. (113 grams) +/- 10%. Ice target is 6 oz. (170 grams) +/- 10%.
- D. If weight is not within range, tap button to enter weight and continue to step 7.
- E. If weight is within range press the red X to exit and choose another flavor, water or ice to calibrate if needed.

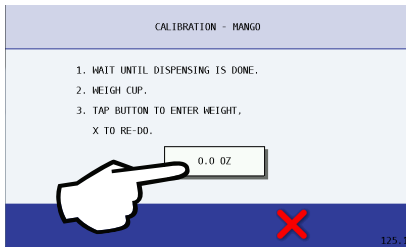

7. The Enter Weight screen will appear.

A. Enter the cup weight using the number pad.

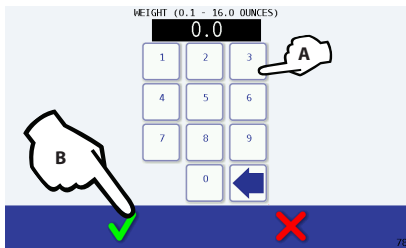

B. Select the Green Check when done to continue.

NOTE: If the weight entered was not 4 oz. (113 grams) for a flavor/water or 6 oz. (170 grams) for ice, the unit will electronically adjust the dispense calibration based on the weight entered to obtain the correct target dispense weight. No mechanical adjustments are required.

8. The calibration screen will display again with the weight entered on the previous screen.

A. If the weight displayed is incorrect, press the button again and re-enter weight.

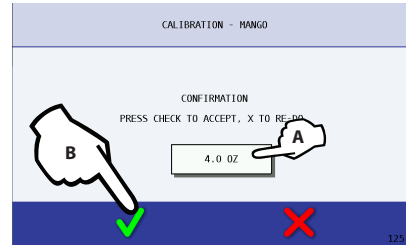

B. Press Green Check when done to save and complete calibration for the slot.

9. The CALIBRATION COMPLETE screen will display.

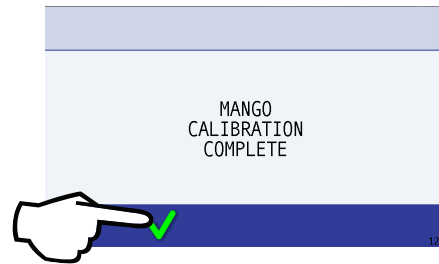

• Press Green Check to return to the Calibration Slot Choice screen.

10. The newly calibrated slot will be highlighted in green.

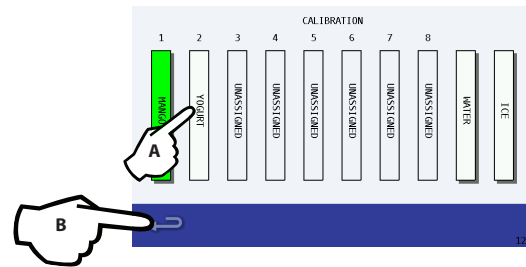

11. Repeat steps 5 - 6 to verify weight is within range.

12. Once weight is within range;

A. Choose another flavor, water or ice to calibrate.

B. Or press the Back Arrow to return to the CONFIGURE SLOTS Screen. From there press the back arrow twice to reach the Main Menu and place the unit into operation.

UPDATES

Firmware and Recipes Screens allow the manager to plug a USB flash drive in and upload new firmware and recipes.

Important

Only a trained manager or authorized technician should perform USB updates. If updates are not performed properly, they can cause the unit to malfunction or not work at all.

These steps are to be followed once the user has gained access to the Manager’s Menu by entering the correct password (Default Password is “A”).

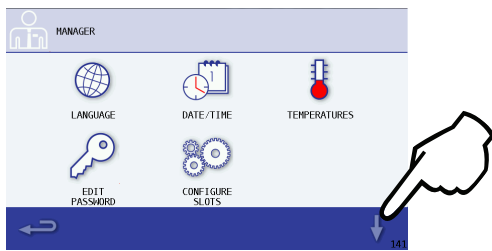

1. Press the down arrow.



- Press the UPDATES icon.

2. There are four (4) submenus, FIRMWARE, RECIPES, CONFIGURATION, and SAVE LOGS TO USB.

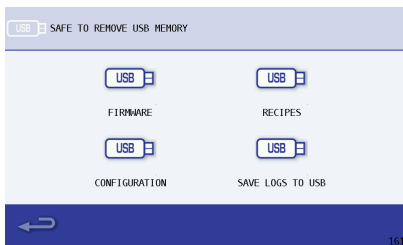

- The FIRMWARE icon is used to update the “easy ToUCH” user interface, Dispenser, and/or the Mixers firmware on the machine. See “Firmware Update Procedure” on page 62.
- The RECIPES icon is used to update or backup the available drink flavors and combinations to or from a USB stick. See “Recipe Loading Procedure” on page 63.
- The CONFIGURATION icon is used for copying a unit’s configuration settings to USB or uploading a previously saved configuration to the unit from USB.

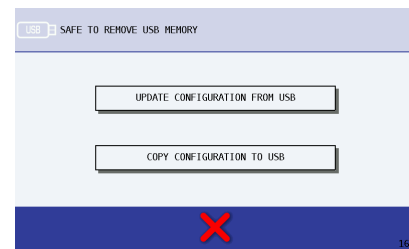

- The SAVE LOGS TO USB icon is used for copying all EVENT and/or ERROR logs to a USB stick.

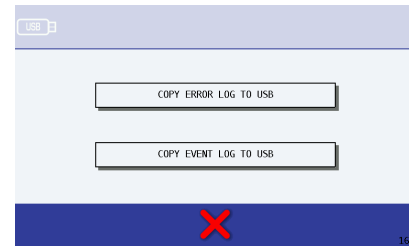

Firmware Update Procedure

Important

1. Read instructions completely.
2. Firmware file must be loaded on top level of flash drive:
 - .BIN for UI updates
 - .SRB for Dispenser (SRB) updates
 - .MXB for Mixer updates
3. Require only 1 firmware file on the flash drive at a time. If multiple firmware files are on the flash drive, choose the correct one when prompted on the screen.
4. Flash drive must be formatted to FAT or FAT32 file format. (Typical for smaller flash drives <2GB.)

1. Plug in the properly formatted flash drive containing the firmware bin file. The USB port is located on the left-hand side of the unit to the right of the power switch.

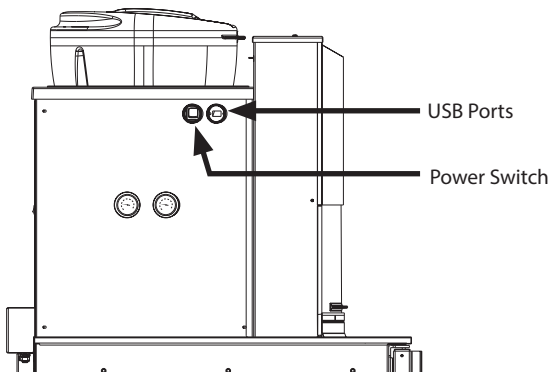

2. From the Main Menu, press the Manager's icon and enter the password (Default password is "A").

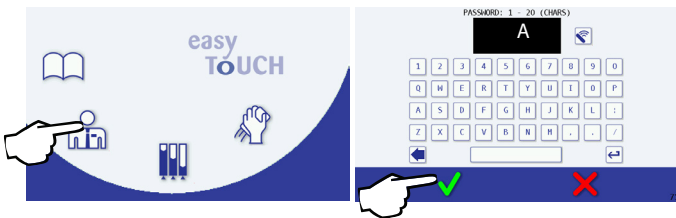

- Press the green check.

3. Press the down arrow.

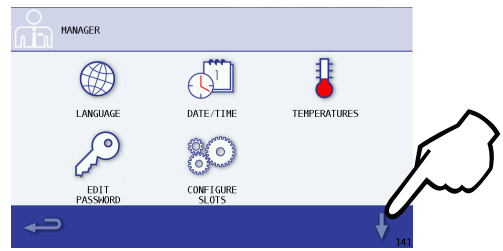

4. Press the UPDATES icon.



5. Press the FIRMWARE icon.

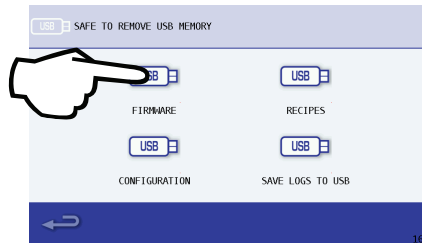

6. Choose which firmware is being updated, USER INTERFACE, DISPENSER, or MIXERS.

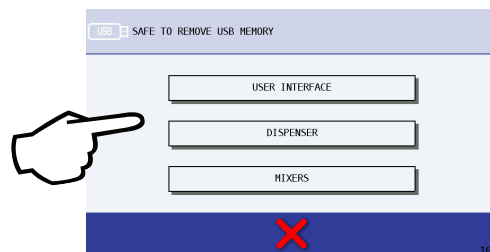

7. Verify version to be loaded is correct.



- Press the green check to begin loading new firmware.

Important

The transfer can take between 10 and 15 minutes to complete. DO NOT remove the USB flash drive!

8. Firmware will show status of update as a percentage, and screen will display "STATUS COMPLETE" when finished.
9. At the Status Complete screen, select the return icon two or three times to go back to the Main Menu screen.

Important

You must CYCLE POWER to the unit after an update before it will take effect.

10. Leaving the USB in place, cycle the power,
 - A. Turn OFF the power switch.
 - B. Wait at least 30 seconds.
 - C. Turn ON the power switch.
11. It is now safe to remove the USB flash drive. Installation is now complete. Press the return icon to go back to the Main Menu.

Recipe Loading Procedure

Important

1. Read instructions completely.
2. Recipe file (.cbr) must be loaded on top level of flash drive.
3. Require only 1 recipe (.cbr) file on the flash drive at a time. If multiple firmware (.cbr) files are on the flash drive, the first one in alphabetical order would be loaded and may not be the correct version.
4. Flash drive must be formatted to FAT or FAT32 file format. (Typical for smaller flash drives <2GB.)

1. Plug in the properly formatted flash drive containing the firmware bin file. The USB port is located on the left-hand side of the unit to the right of the power switch.

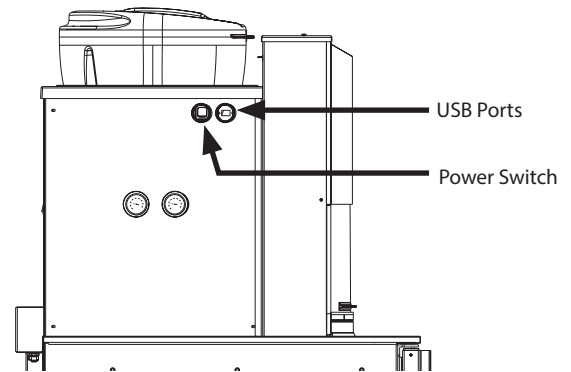

2. From the Main Menu, press the Manager's icon and enter the password (Default password is "A").

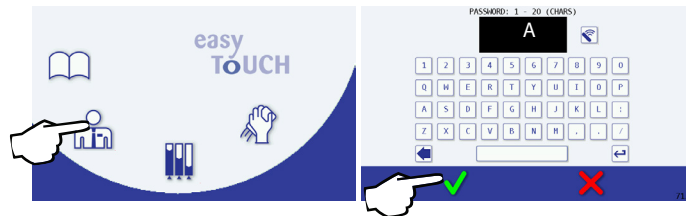

- Press the green check.

3. Press the down arrow.

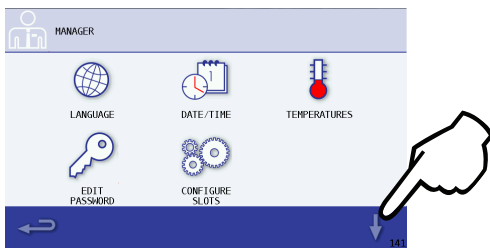

7. Verify version to be loaded is correct.

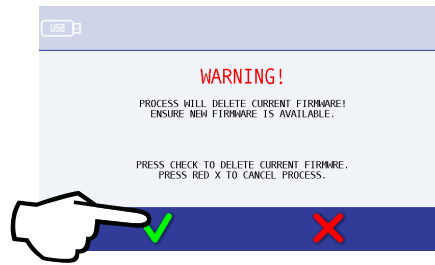

4. Press the UPDATES icon.



- Press the green check to begin loading recipe file.

8. Recipe will show status of update as a percentage, and screen will display "STATUS COMPLETE" when finished.

9. At the Status Complete screen, select the return icon two or three times to go back to the Main Menu screen.

Important

You must CYCLE POWER to the unit after an update before it will take effect.

5. Press the RECIPES icon.

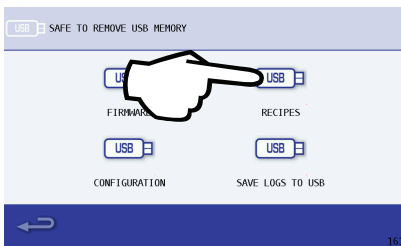

10. Leaving the USB in place, cycle the power,

A. Turn OFF the power switch.

B. Wait at least 30 seconds.

C. Turn ON the power switch.

11. It is now safe to remove the USB flash drive. Installation is now complete. Press the return icon to go back to the Main Menu.

6. Press UPDATE RECIPES FROM USB.

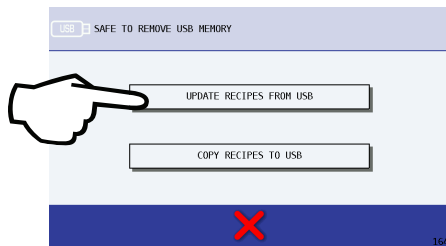

Auto Wash Timers

Allows the manager to turn ON / OFF, and set up periodic automatic wash cycles for the blender stations. Up to six (6) timers can be set.

These steps are to be followed once the user has gained access to the Manager’s Menu by entering the correct password (Default Password is “A”).

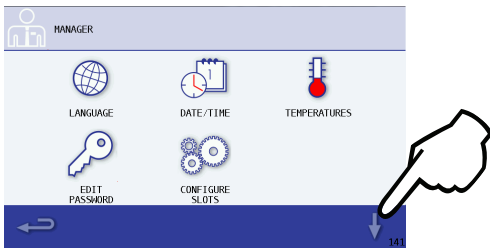

1. Press the down arrow.

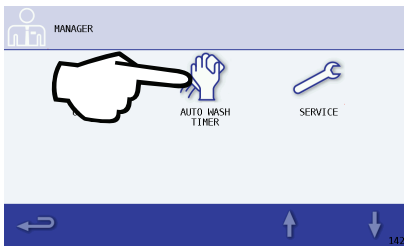

- Press the AUTO WASH TIMER icon.

2. By default no timers are preset.

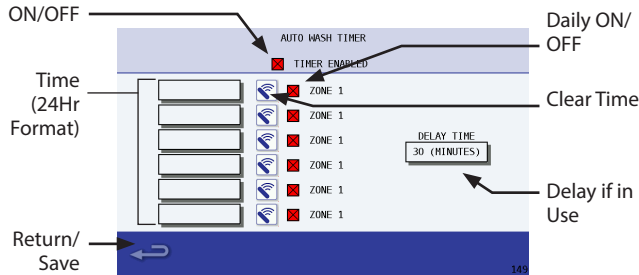

3. To save any changes, press the return arrow and return to the Manager’s Menu. When exiting the Manager’s Menu, all changes will be confirmed.

Service Screens

Allows the manager and qualified service technician access to optional functions, settings, input, and output readings used in both setup and diagnostics.

Important

Only a trained manager or authorized technician should access the service screens. If changes to these settings are made incorrectly they can cause the unit to malfunction or not work at all.

These steps are to be followed once the user has gained access to the Manager’s Menu by entering the correct password (Default Password is “A”).

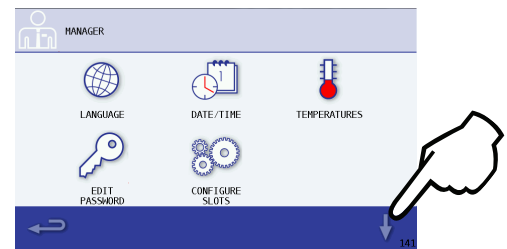

1. Press the down arrow.

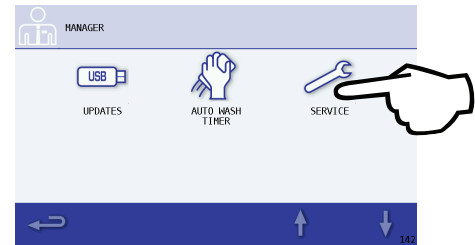

- Press the SERVICE icon.

2. The service screens are password protected. Enter the service password (default password is “A”).

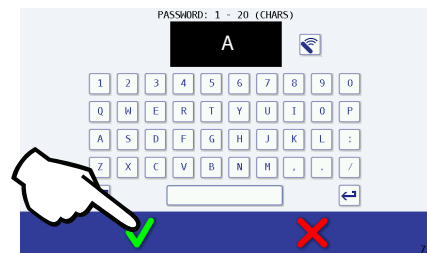

- Press the green check.

- 3.

4. The following choices will be made available;

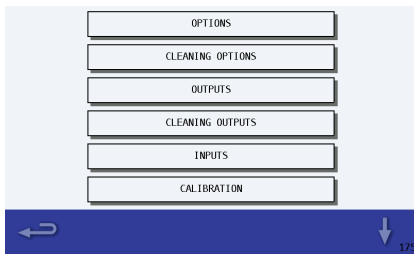

- **OPTIONS**
Turn ON/OFF the following; Mixer Rinse, Water Saving Rinse, Left Mixer, Right Mixer, Condenser Filter(s).
- **CLEANING OPTIONS**
Set Zone 2 and 3 timer durations. Enable sanitizing in Zone 2 cleaning. Enable Descaling in Zone 3 cleaning.
- **OUTPUTS**
Displays current state of all drink component outputs and can be toggled ON/OFF from this screen.
- **CLEANING OUTPUTS**
Displays current state of all cleaning component outputs and can be toggled ON/OFF from this screen.
- **INPUTS**
Displays current state of all input components.
- **CALIBRATION**
Displays current state of all calibration settings.
- **Press the down arrow for more choices.**

5. The second screen displays more service choices:

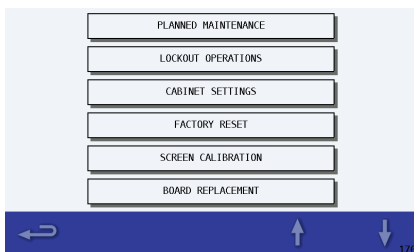

- **PLANNED MAINTENANCE**
Password protected screen only meant for the service technician performing the planned maintenance.

- **LOCKOUT OPERATIONS**
DEMO mode will password protect all icons once the user saves settings and returns to the Main Menu. Enter "DEMO" in the password screen to gain temporary access to the Drink, Inventory, and Cleaning screens. "A" is the default password for the Manager's Menu.

SELF-SERVE mode will limit the user to just drink making screens and password protect the Main Menu. Enter "SELF" in the password screen to gain temporary access to the Main Menu. "A" is the default password for the Manager's Menu.

- **CABINET SETTINGS**
Displays all current cabinet settings. Touch a setting to change its value.
- **FACTORY RESET**
Resets all calibrations to factory settings.

Caution

This will erase all settings that have been set manually.

- **SCREEN CALIBRATION**
Calibrates the touch screen sensitivity.
- **BOARD REPLACEMENT**
Used when a UI or Mixer board is being replaced.
- **Press the down arrow for more choices.**

6. The third screen displays more service choices:

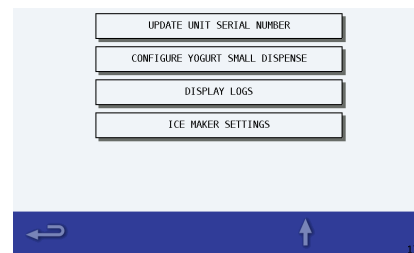

- **UPDATE UNIT SERIAL NUMBER**
Used to input the unit serial number post installation.
- **CONFIGURE YOGURT SMALL DISPENSE**
Displays the yogurt small dispense settings, and can be adjusted from this screen.
- **DISPLAY LOGS**
Allows the user to display and/or clear all ERROR and EVENT logs on screen.
- **ICE MAKER SETTINGS**
Displays all ice maker settings and can be adjusted from this screen.

Software Version Screen

Allows the manager and qualified service technician to see on screen what software versions are currently installed.

These steps are to be followed once the user has gained access to the Manager’s Menu by entering the correct password (Default Password is “A”).

1. Press the down arrow.

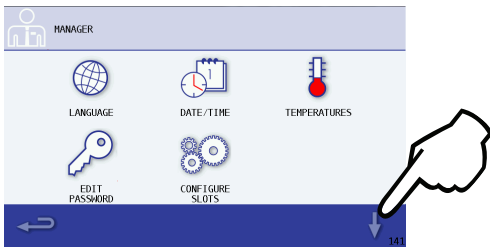

2. Press the down arrow.

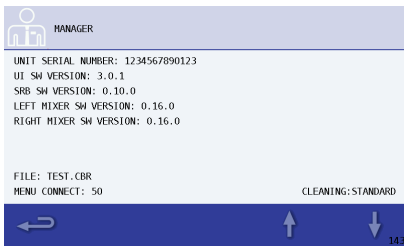
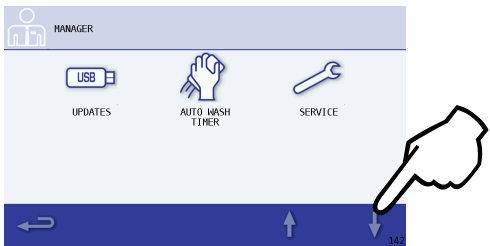

3. The screen will display the loaded software version numbers for the UI, SRB, Left & Right Mixer, and current recipe file name.

Drink Counter Screen

Allows the manager and qualified service technician to see on screen how many drinks the unit has made since installation and last maintenance date.

These steps are to be followed once the user has gained access to the Manager’s Menu by entering the correct password (Default Password is “A”).

1. Press the down arrow.

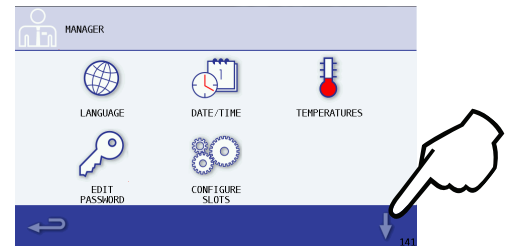

2. Press the down arrow.



3. Press the down arrow.



4. The screen will display how many cycles each mixer has made and the total count.

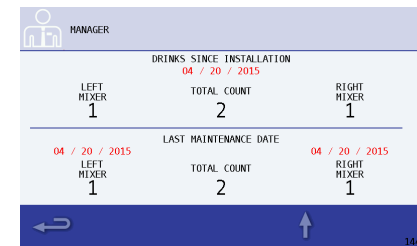

PRODUCT INVENTORY SCREEN

This screen's primary function is to provide visual product inventory information for the user. The Product Inventory screen is normally accessed through the Main Menu.

How to Access



1. Press the Inventory Icon from the Main Menu.

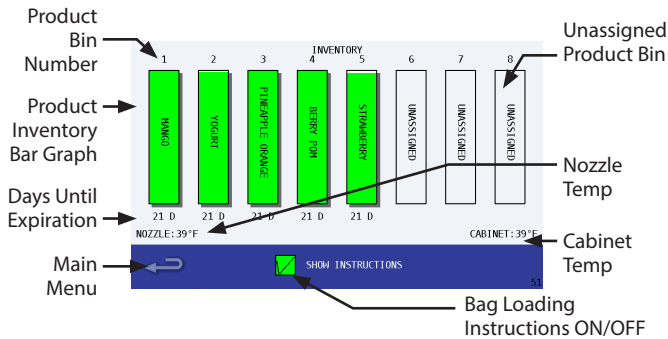

The inventory screen visually displays levels for all flavors. Underneath each flavor is the time remaining until the flavor expires in days. NOZZLE and CABINET temperatures are also on the inventory screen. When a flavor is touched on the screen, the instructions to replace a product bag will begin.

Icon Button Descriptions

- **Product Bin Number**
Displays the product bin number the Product Inventory Bar Graph represents.
- **Product Inventory Bar Graph**
Product inventory tracking estimates the remaining flavoring in each product's bag in the reach-in compartment in 5% increments.
 - **Green Bar**
Product inventory is above 10% and not near expiration.
 - **Yellow Bar**
Product inventory has fallen below 10% or less than 2 hours until product expiration.
 - **Red Bar**
If the bar representing a product's inventory level is red, the bag has expired, has not been installed, or the slot needs cleaning. Replace product as necessary. (See "Procedure to Install a Product Bag" below.)
 - **UNASSIGNED**
If UNASSIGNED is displayed below the product bin number, no product is currently assigned to the bin.
- **NOZZLE Temperature**
Displays the current temperature near the dispense point. Can be set to Celsius or Fahrenheit in the Manager's Menu. (See "Temperature Setting" on page 56.)
- **Back Arrow**
Navigates to previous Main Menu screen.
- **Days Until Expiration**
Displays the number of days remaining until the product bag expires. Pressing the corresponding product bar graph will access the Replace Product screen, displaying the steps to follow for replacement. (See "Procedure to Install a Product Bag" below.)
- **CABINET Temperature**
Displays the current temperature in the refrigeration cabinet. Can be set to Celsius or Fahrenheit in the Manager's Menu. (See "Temperature Setting" on page 56.)
- **Show Instructions**
 - ☑ = Show bag loading instructions on screen
 - ☒ = No instructions on screen

Procedure to Install a Product Bag

1. From the Main Menu touch the Inventory icon.



2. On the Inventory screen, select the product to be installed.

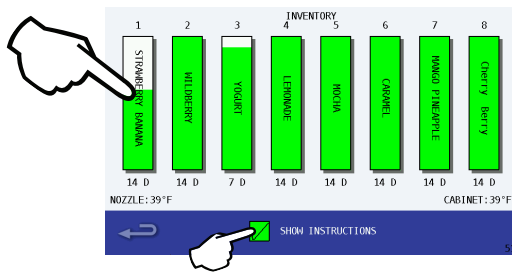

NOTE: To see the on screen instructions during bag load the "Show Instructions" will need to be ON and displaying a green box with a check mark.

- Products with less than 10% inventory or less than 2 hours until product expires will be displayed with a yellow bar.
- Products that are expired will be displayed with a red bar.

3. Prepare unit for new product bag.

- Remove product bin from cabinet and discard empty bag.
- Wipe the inside of the product bin with a clean towel.
- Place new product bag with the spout facing down into product bin.

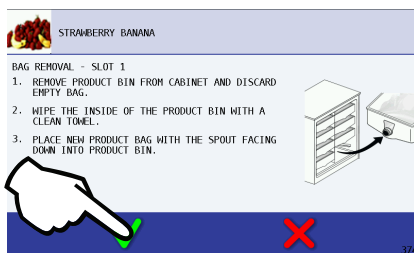

- Follow the on screen instructions.

4. Press the green check to continue.
5. Position rear groove of the spout on product bag into slot of the product bin.

Important

The spout must snap into the slot of the product bin!

6. Open and remove the cap on the product bag.
7. Return product bin to its position in cabinet.
8. Press the green check to continue.
9. Select inventory level from FULL BAG, PRIME FLAVOR or NO BAG.

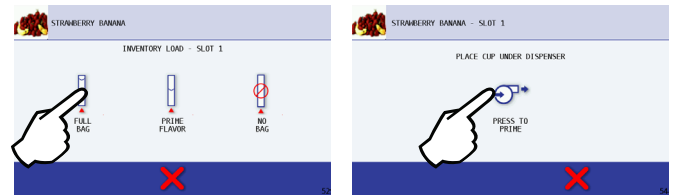

10. Select FULL BAG went installing a new product bag and the Prime screen will display.
11. Place cup under dispenser and press the Prime icon to prime the line with the new product bag, DISPENSING will display on the screen. Repeat until product consistently flows into the cup.
12. Press the green check to continue.

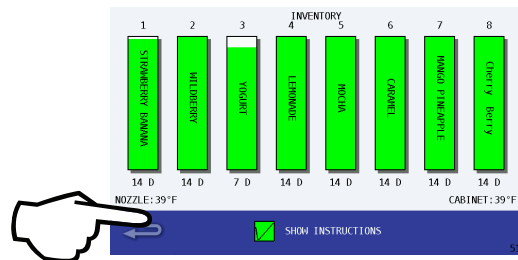

13. Installation is now complete. The inventory bar will now display full, green, and days until expiration reset.
14. Select another product to be installed or return to the previously active screen by pressing the return arrow.

Important

Resetting a product's inventory without replacing the product bag will cause the Product Inventory screen, percentages, and life to be inaccurate.

CLEANING SCREEN

The Cleaning screen appears after selected from the Main Menu or when prompted to perform routine cleaning. This screen's primary function is to perform routine cleaning and sanitation of the machine.

How to Access



1. Press the Cleaning icon from the Main Menu.

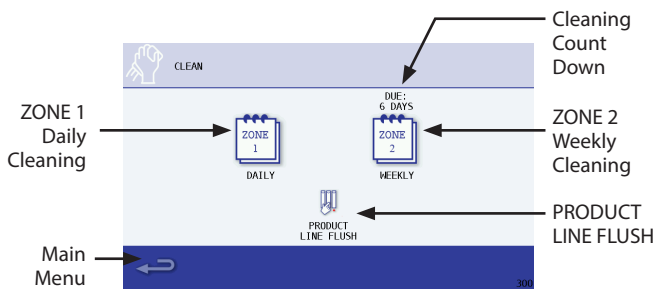

* If equipped with this option

Icon Button Descriptions

- **ZONE 1 - Daily Cleaning**
Displays the Daily Cleaning screen and guides the user through all daily cleaning requirements.
- **ZONE 2 - Weekly Cleaning**
Displays the Weekly Cleaning screen and guides the user through all weekly cleaning requirements.
- **Back Arrow**
Returns to the previous screen or Main Menu.
- **Cleaning Count Down**
Days left until Cleaning is required. Shown in DAY increments, changes to HOURS when there is less than a day (24 hours) until cleaning of the machine is required. Resets once cleaning has been completely performed.

Important

Once the time limit has been exceeded the machine will no longer make a drink until cleaning has been completed.

- **PRODUCT LINE FLUSH**
Displays the Product Line Flush screen and guides the user on how to flush a single or all product lines. See Installation, Operation and Maintenance manual.

Section 7

Component Check Procedures

Component Identification

EXTERNAL

For Model specific regulator orientation, Air/CO2 & Water connection See Regulator Settings & Location page 14

Front

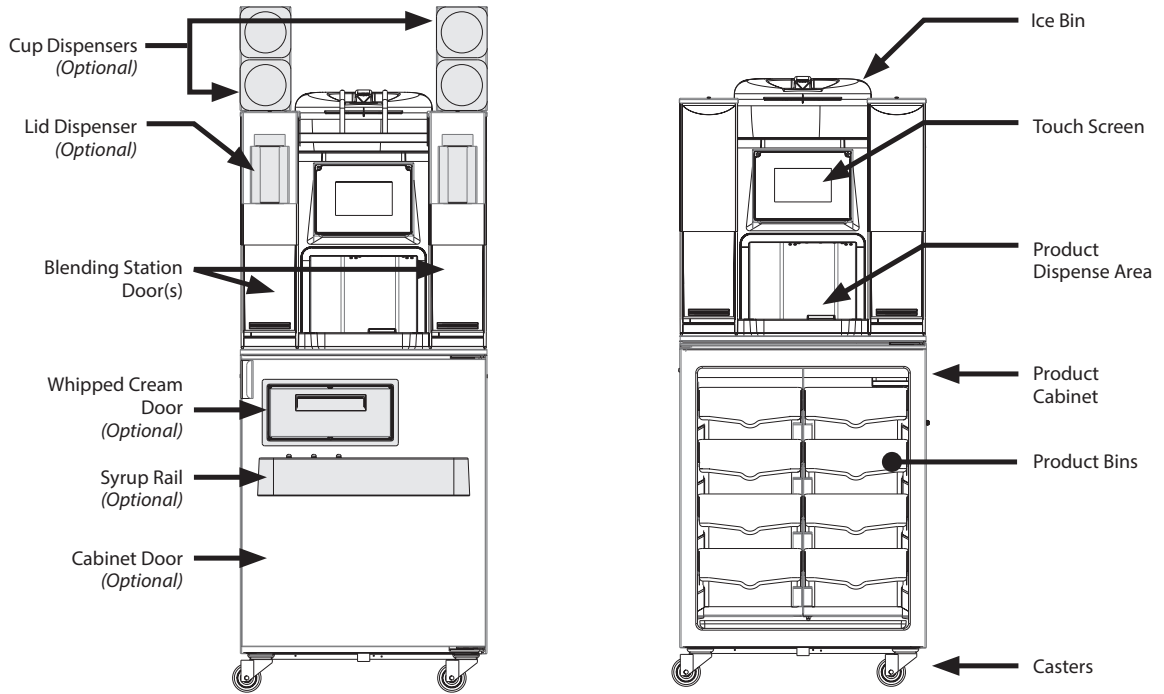

Left Side

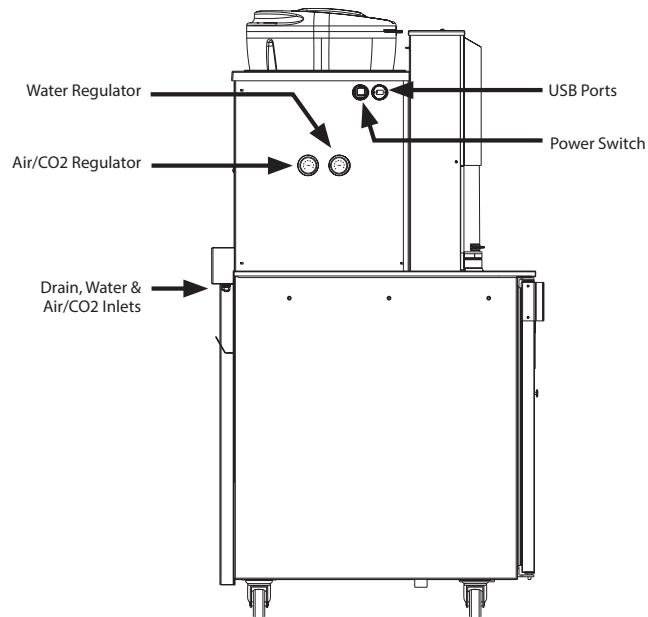

INTERNAL

Top Left

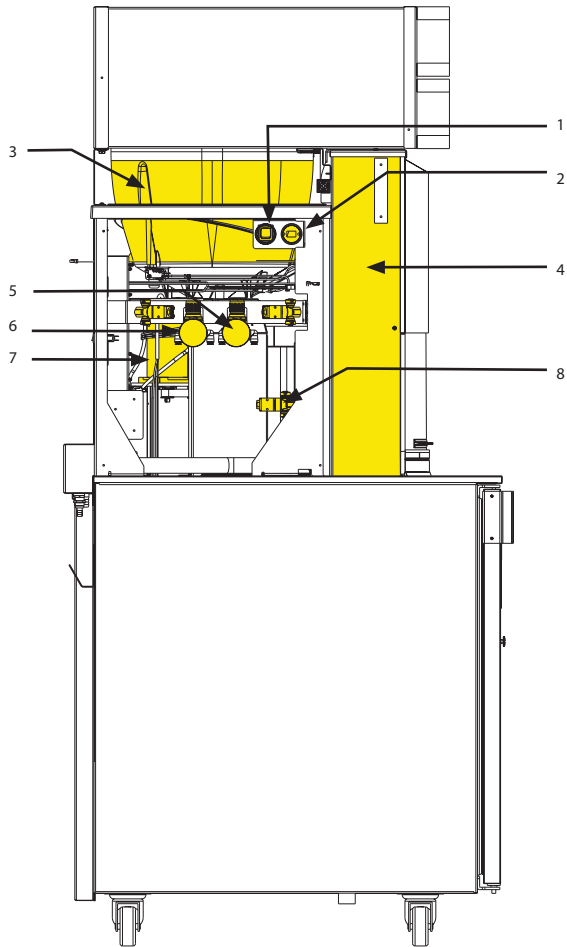

- 1. Power ON/OFF Switch
- 2. USB Port
- 3. Ice Bin
- 4. Modular Blender
- 5. Plain Water Regulator
- 6. Product Air/CO₂ Regulator
- 7. Shaver Motor
- 8. Rinse Solenoid

Top Right

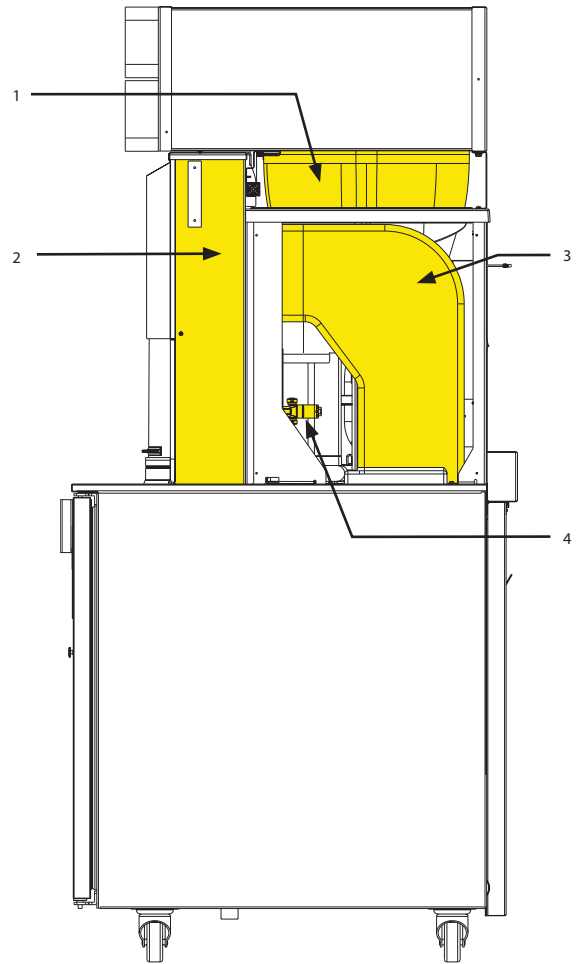

- 1. Ice Bin
- 2. Modular Blender
- 3. Air Duct
- 4. Rinse Solenoid

Bottom Cabinet - All Models

PUMPS & SOLENOIDS

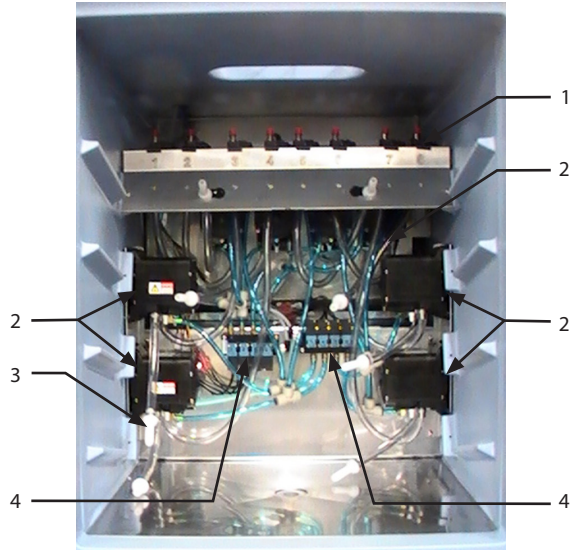

- 1. Non Drip Valves (x8)
- 2. Product Pumps (x8)
- 3. Product Bag Nozzles (x8)
- 4. Solenoid Valves (x2)

REFRIGERATION



- 1. Duct Fan
- 2. Evaporator Coil
- 3. Evaporator Fans (2)
- 4. Cabinet Sensor

PUMP & SOLENOID NUMBERING

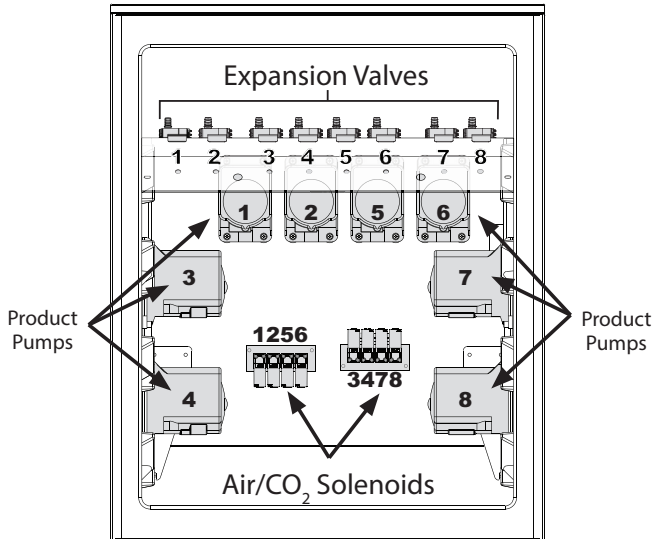

These numbers correspond to the product bins and inventory numbers in the User Interface.

Control System

ON/OFF ROCKER SWITCH

Location

The ON/OFF switch is located on the left side of the unit when viewing from the front.

Function

Supplies power to the Blender components. Turns unit ON and OFF.

Specification

This is a rocker switch with a double pole, double throw switch.

Check Procedure

To check the switch, unplug the power supply to the equipment.

1. Check for loose or broken wires at that terminal.
2. Remove the wires (marked #14) and with your ohm meter check continuity between (2) two terminals in the ON position.

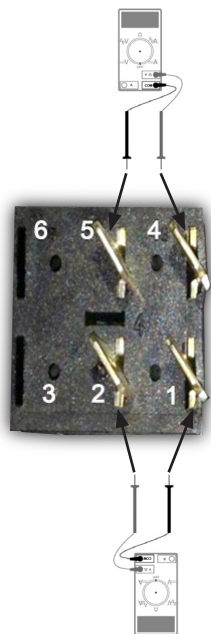
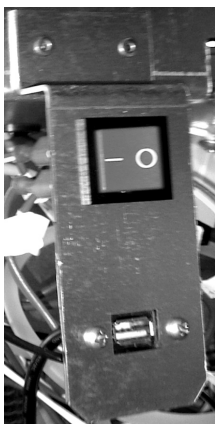

3. There should be continuity.
4. If no continuity is read, replace the switch.
5. Press the switch to the OFF position (O).
6. Check continuity between the (2) two terminals, there should be no continuity between the terminals.
7. If continuity is read, replace the switch.

POWER RELAY

Location

Located behind the left-hand side panel.

Function

Removes full load amperage of components and motors from ON/OFF rocker switch.

Specification

Double Pole Single Throw (DPST), 220 VAC coil, average coil resistance 21 KOhms, Contact rating - 30A @ 120 VAC. When energized, contacts close and allow power to flow to SRB board (J9 & J10), Power Supply (CN1), and Evaporator Fans.

Check Procedure

There is a small black manual push button on the relay body to allow testing of the contacts with the unit de-energized. Disconnect the wiring to the contacts and check resistance while pressing the test button. The resistance across the contacts should be less than 1.0 ohms.

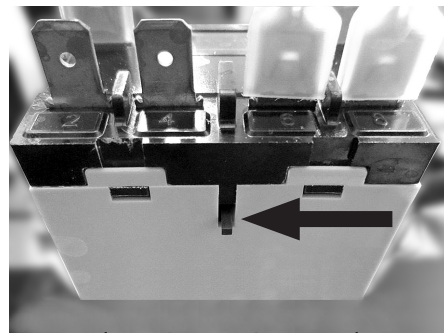

- Manual Test Button, Press to close contacts.

If the relay is energized and contacts are closed the button will be pulled in, flush with the body of the relay.

Power Relay Coil Test Procedure

1. Check the coil using an ohm meter, the coil should have a nominal resistance reading. If no reading the coil is open and the Power Relay should be replaced.
2. With the ON/OFF rocker switch in the ON position, check for line voltage at relay coil.
 - Line voltage present - Contacts should be closed, if not replace the relay.
 - No line voltage present - Refer to ON/OFF rocker switch check procedure.

POWER SUPPLY**Location**

The 24 VDC power supply is located behind the left side panel.

Function

Reduces and converts voltage for use on the control circuit.

Specifications

Steps down voltage from:

90 - 264/50-60/1 VAC to 24 VDC 8.4 A

Check Procedure

1. Inspect for correct wiring.
2. Check for line voltage at transformer primary CN1.
 - No line voltage present - Refer to power relay and toggle switch check procedures.
 - Line voltage present - Continue diagnostics.
3. Check voltage at transformer secondary CN3.
 - 24 VDC present - Transformer is OK.
 - 24 VDC is not present - Isolate secondary wiring and check for 24 VDC.
 - 24 VDC present - Repair wiring or replace effected component(s).
 - 24 VDC is not present - Replace Power Supply.
 - One LED light - constant on to indicate power is applied - located at the lower left corner of CN3.

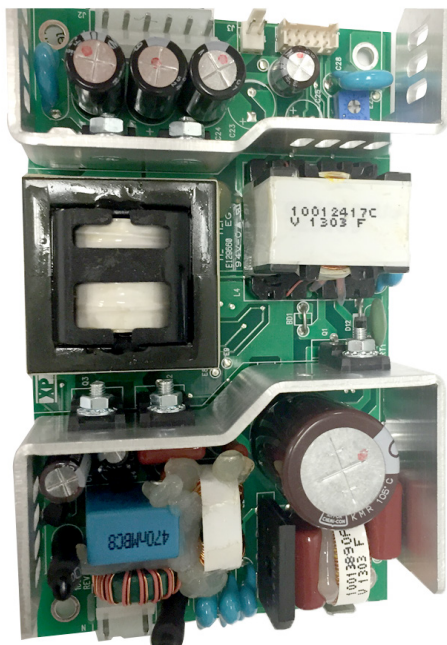
POWER SUPPLY BOARD**UI (USER INTERFACE - TOUCHSCREEN)****Location**

The User Interface is located on the upper front section of the BIC unit.

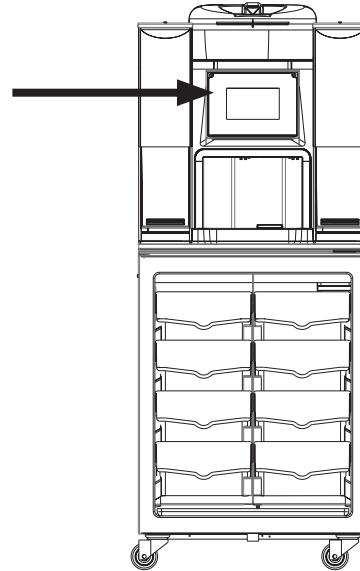
**Function**

The UI provides a method for the user to instruct the machine to a specific task, such as making drinks and providing cleaning instructions. The UI receives inputs from the user via screen touches and executes the function based on the current firmware.

The UI processes inputs and sends signals to the SRB relay board to energize and de-energize components. The UI is the main control board of the BIC unit.

Specifications

The UI assembly is made up of an integrated control board along with a touchscreen panel. A Modbus communication cable provides the path of communication as well as the power supply for the UI. The UI is also equipped with a USB port for uploading firmware to each of the system boards and the customer's recipe file.

Check Procedure

1. Reboot machine by moving toggle switch off/on or disconnecting and reconnecting main power supply.
2. With the power off, remove the UI from the front of the unit. Verify the communication cable connection is secure by removing and reinserting the connector. Safely position the UI assembly, power up and check display.
3. With the power off, remove the UI from the front of the unit but do not disconnect the cables. With the UI safely positioned power up the unit and check the LED indicator lights on the integrated control board of the UI assembly. There are a total of 4 that will illuminate. See "UI (User Interface)" on page 77.
 - D1 12V RAW Power - GREEN
From Power Supply
 - D2 5V Power - GREEN
Power is available on the UI
 - D3 3.3V - GREEN
Power is available on UI to USB
 - D10 RED (Status) Microprocessor
is active and operational
4. If no LED lights are illuminated, turn the power off and disconnect the power supply cord. Inspect the ribbon cables and power supply connection between the integrated control board and touchscreen panel. Ensure connections are secure, safely position the UI assembly and connect the power cord and power up the unit. Again check the LEDs for activity.
5. If no LED lights are illuminated, turn the power off and disconnect the power supply cord. Remove the lid holder support rail system, the top and left side panels. Check the UI communication cable connection at the SRB board - J6. Verify the connection is secure by removing and reinserting the connector.
6. With the power supply cord disconnected, disconnect the 24 VDC power input from the SRB board at J35. Connect the leads of your multimeter to the 24 VDC connector and properly set the meter to test for the anticipated DC voltage. Power the unit back up and check for 24 VDC supply.
7. If 24 VDC power is verified at the connector, turn the power off and disconnect the power supply cord. Disconnect the 24 VDC connector from the multimeter and reconnect to the SRB board at J35. Power up the unit and check the UI LEDs. If no LED activity - Replace the UI.
8. If 24 VDC power is not present, power down and check the inline 4 amp fuse between the SRB board and the 24 VDC power supply, also located behind the left side panel. If the fuse checks open it will need to be replaced.
9. If the fuse checks closed, connect your multimeter leads to the output connection of the 24 VDC power supply - CN3, (T1 - T3 are +24 VDC / T4 - T8 are -24 VDC). Properly set the meter to test the anticipated DC voltage and power up the unit.
10. If 24 VDC power is not present, power down the unit and refer to the test procedures for the 24 VDC Power Supply. If the UI is not operational after the 24 VDC power is restored, repeat the above test.

UI (USER INTERFACE)

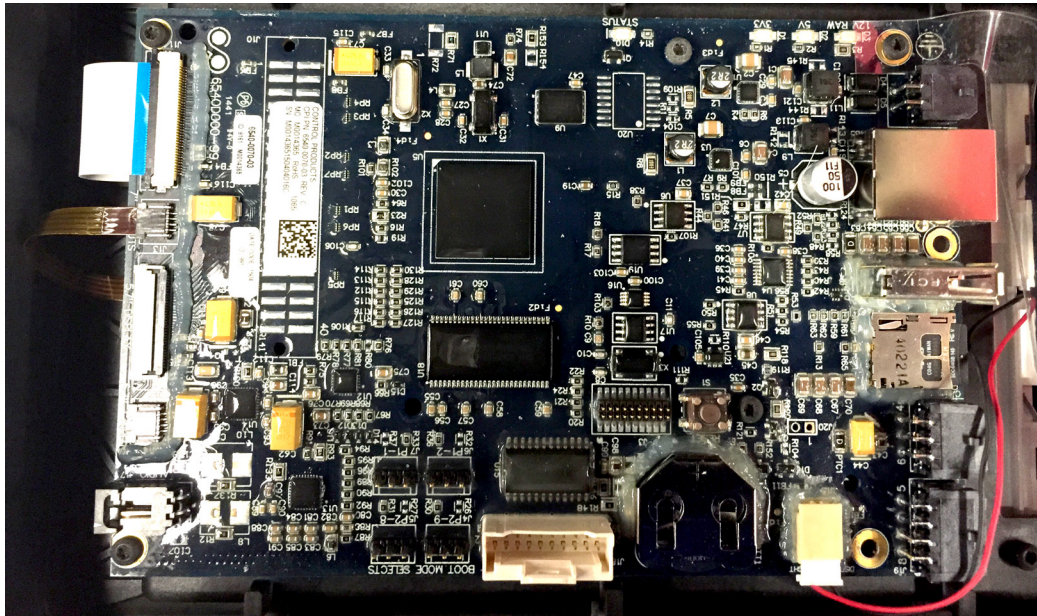

SRB BOARD

Location

The SRB board is located behind the left side panel.

Function

The SRB board receives inputs from various controls and outputs power as needed to various components at specific times based on the current firmware and activity of components. The SRB board is the central hub of operations. Communications and power distribution all connect through the SRB board.

Specifications

The SRB board receives and distributes 230 VAC, 24 VDC, & Modbus communication capabilities to various components. The SRB functions are controlled by the onboard firmware in conjunction with signal inputs from the UI, the blender boards, thermistor probes, ice wheel reed switch, and the ice bin level sensor. SRB firmware can be uploaded via the USB port near the power switch on the left side of the unit.

Check Procedure

The SRB board can be verified as good or deemed to be defective based on input and output test.

1. Using the UI, go to the Output screen - (Managers Menu> Service Menu> OUTPUTS).
2. From the Outputs screen select the load to be tested from the list.

OUTPUTS	
COMPONENT	CURRENT STATE
FLAVOR SOLENOID 1:	OFF
FLAVOR SOLENOID 2:	OFF
FLAVOR SOLENOID 3:	OFF
FLAVOR SOLENOID 4:	OFF
FLAVOR SOLENOID 5:	OFF
FLAVOR SOLENOID 6:	OFF
FLAVOR SOLENOID 7:	OFF
FLAVOR SOLENOID 8:	OFF

3. The current state of the load will normally be "OFF" and touching the screen in the green area will turn the load "ON" - color changes to red, text changes to "ON".
4. If the selected load does not come on, this could indicate an issue with the selected component, the SRB board, or a voltage supply issue.
5. Select a different load that requires the same power - another line voltage load or another low voltage load.
6. If no line voltage loads operate, verify the line voltage, 230 VAC, is present at J9 (N) & J10 (L1).
7. If incoming line voltage is not present at J9 & J10, verify the wiring is intact and connected to the Power

Relay. Follow Power Relay and/or Power Switch check procedures if power is not available at the Power Relay.

8. If no low voltage loads operate, verify the low voltage, 24 VDC, is present at J35.
9. If a single load does not operate, low voltage or line voltage, it is possible the load is defective. Refer to the check procedures for the particular load.
10. Refer to the wiring diagram for the SRB input and output connections.

Terminals:

ACROSS THE TOP EDGE

- J15 (N) / J16 (L1) - Right Blender Control 230 VAC
- J11 (N) / J12 (L1) - Left Blender Control 230 VAC
- J27 (N) / J28 (L1) - CIP Enable 230 VAC
- J24 (N) / J23 (L1) - Bin Level Relay 230 VAC
- J21 / J22 - Future Use
- J17 / J18 - Future Use
- J25 (N) / J26 (L1) - Ice Carousel 230 VAC
- J13 (N) / J14 (L1) - Cabinet Refrigeration 230 VAC
- J19 (N) / J20 (L1) - Ice Compressor 230 VAC
- J9 (N) / J10 (L1) - 230 VAV Switched Input Voltage

LEFT SIDE

- J1 - Pins 1-9 Switched -24 VDC Product solenoids / Pin 10 dispense water valve / Pin 11 +24 VDC to product solenoids
- J2 - Signal Inputs - Bin Level Sensor / Ice Wheel Reed Switch

RIGHT SIDE TOP TO BOTTOM

- J34 - Defrost Thermistor Probe
- J33 - Nozzle Thermistor Probe
- J32 - Cabinet Probe
- J31 - N/A
- J30 - N/A
- J29 - N/A

BOTTOM

- J4 - No connector (not used)
- J6 - Modbus / UI Communication
- J5 - Future Use
- J7 - Modbus / Right Blender Communication
- J8 - Modbus / Left Blender Communication
- J35 - 24 VDC Input
- J36 - Duct Fan / 24 VDC

SRB BOARD

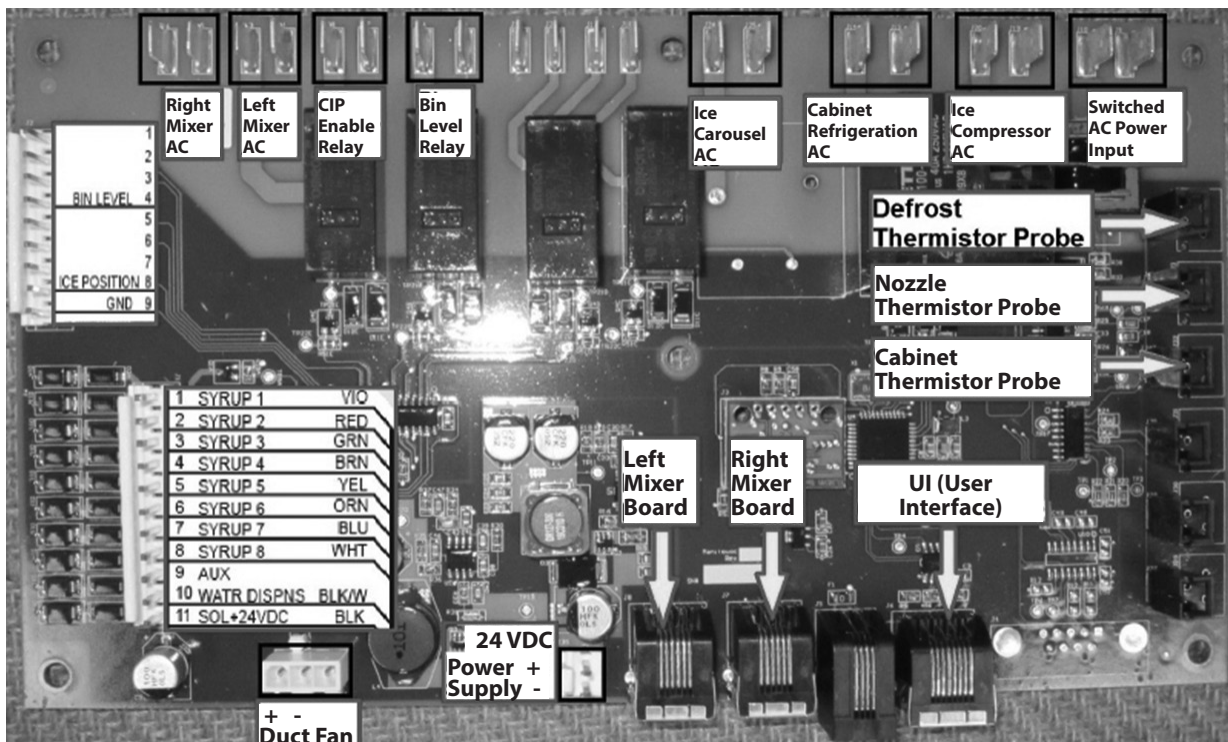

BLENDER CONTROL BOARD

Location

Each blend chamber has a dedicated Blender Control Board. The Blend Chamber Assembly needs to be separated from the frame in order to access the blender control board.

Function

The Blender Control Board provides control of the blender position, up/down movement of the linear slide, and on/off motor operation. The Blender Control Board is software-driven and retains firmware which can be updated via the USB port, near the power switch on the left side of the unit.

Specifications

The Blender Control Board receives 230 VAC line voltage and 24 VDC low voltage. The blender board executes the blend profile of the customer's recipe when a drink is selected. The board will distribute voltage to the blender motor, linear slide, or the rinse water solenoid as instructed according to the current firmware and instruction from the UI. Instruction from the UI is transmitted via Modbus communication cable connected at J4. The blender also receives input from the blender door reed switch and the blender home position switch.

Check Procedure

The Blender Control Board function can be tested via the "Outputs" in the UI service screen. (Managers Menu> Service> OUTPUTS). Operate the blender blade to verify blade operation and/or the blender slide to verify linear slide operation.

To test the motor blade it's best to place a cup of water in the blend chamber to be tested, activate the blender slide on the side to be tested, and then activate the blender blade. This will allow for a better visual of the blade turning.

NOTE: The blender blade will only operate for 3 seconds at half voltage in this test function.

The blender door must be fully closed to allow blender operation. The door position can be confirmed using the "Inputs" screen - Managers Menu> Service> INPUTS. This will verify the software is correctly reading the door position. Open the perspective door (left / right) and the Input should report the current condition, "open" or "closed".

Blender Board connections:

- J5 (N) / J6 (L1) - 230 VAC
- J2 (N) / J7 (L1) - 230 VAC (Present with relay closed)
- J12 - Rinse Water Solenoid Valve, 24 VDC
- J4 - Modbus communication
- J9 - Reed Switch / 3 wire
- Brown to White - NC
- Green to White - NO
- J13 - Home position switch - NO
- J10 - Linear Slide Stepper Motor
- J1 - 24 VDC input (T1 +24 VDC / T2 -24 VDC)
- Onboard fuse - protects blender motor output circuit, 2.5 amp.
- DIP switch settings - All in the "OFF" position identifies the left side board, #1 switch in the "ON" position and #2, 3 & 4 in the "OFF" position identifies the right side board.
- Has one LED:
 - Constant when first powered on.
 - Blinks when linear slide reaches home.
 - Heartbeat after homing is accomplished.

NOTE: See "Blender Control Board" on page 80.

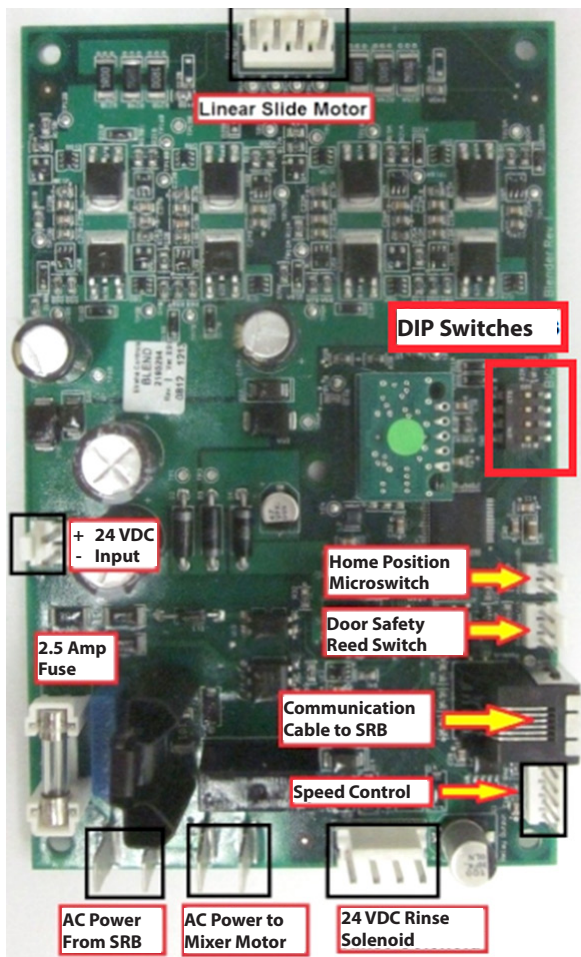
BLENDER CONTROL BOARD**SYRUP SOLENOID VALVE****Location**

- In the base unit behind the product bin trays and the bin back support panels. See "Refrigerated Cabinet" on page 85.
- In the base unit behind the product trays and the steel dividers. See "Refrigerated Cabinet" on page 85.
- Syrup Solenoid harness - LHS Rear of the unit on the CIP board position P2.
- Color coded 11-pin connector block.

Function

Controls supply of CO₂ to product pump when required once the product has been selected by the recipe.

Specifications

- 24 VDC
- Single black wire is continuous +24 volts supply, the colored wires are neutral and represent each solenoid coil 1-8.
- 8x solenoid coils are N/C.

Check Procedure

1. Verify pressure regulator setting is correct. 35 psi dynamic.
2. Verify pressure is present at valve inlet.
 - Check by activating another valve on the same block. ie 1256-3478
3. Check for 24 VDC at the black terminal and at the selected color on the 11 pin connector. Position 2 on the CIP board.
 - 24 volts is not present - Refer to "Home Position Switch" on page 83.
 - 24 volts present - Continue
4. Remove the brass CO₂ fitting from either the BIB Pump or the Expansion Valve, activate the solenoid in question and depress the diaphragm within the brass fitting.
 - CO₂ is not present – Check for kink in line. If no kinks are present.
 - CO₂ present at BIB Pump – Replace BIB pump.

NON DRIP VALVE**Location**

- In the base unit behind the product trays on the top rail. See "Refrigerated Cabinet" on page 85.

Function

As the Air/CO₂ is applied, the diaphragm will flex to decrease the product volume inside the valve, when the air is released the diaphragm returns to its position increasing the volume and this causes a back feed from the LMS valve. Preventing excess product from releasing from the LMS valve.

See "Dispense System Diagram" on page 119.

Specifications

- Requires Air/CO₂ pressure to operate.

Check Procedure

1. Product dripping for an extended period of time from a single valve or product has a short dispense from a single valve following valve solenoid shut down.
2. Verify pressure regulator setting is correct +35 psi (.24 MPa, 241 kPa, 2.41 bar).
3. Verify pressure is present at the non drip valves CO₂ brass fitting inlet by disconnecting the fitting from the Non Drip Valve and depressing the NRV.
4. Verify cabinet temperature is not below freezing. A frozen valve can be thawed and made operational.
5. Clear blocked line; See "Procedure to Clear Blocked Line" on page 62.
6. Disconnect the air line from the Valve and press the NRV on the supply line to verify pressure is present.

NOTE: Air/CO₂ has high back pressure, please wear PPE.

7. CO₂ Present
 - No – See *Syrup Solenoid Valve page 80*
 - Yes – Remove product flavor and flush circuit with hot sanitized water until line runs clear. Replace product and test for drip or dispense following solenoid shut down. If either exists replace the non drip valve
8. If pressure is present, then a new non drip valve will be required.

PRODUCT PUMP**Location**

- In the base unit behind the product trays and steel dividers. See "Refrigerated Cabinet" on page 85.

Function

Transfers product from bag to cup.

Specifications

Pressure operated, requires 35 psi (241 kPa) Air/CO₂ pressure Dynamic.

Check Procedure

1. Verify cabinet temperature is not below freezing. A frozen pump and or solenoid valve can be thawed and made operational.
 2. Clear blocked line; See "Procedure to Clear Blocked Line" on page 62.
 3. Verify pressure regulator setting is correct.
 4. Verify pressure is present at the product pump inlet by disconnecting the brass CO₂ supply fitting from the BIB Pump and depressing the NRV.
 5. Disconnect the air line from the valve and press the NRV on the supply line to verify pressure is present.
- NOTE: Air/CO₂ has high back pressure, please wear PPE.
6. Disconnect pressure inlet line and product inlet and outlet lines from product pump.
 7. Point pump inlet/outlet away from face and reconnect inlet pressure line:
 - Pump cycles - Check for pinched lines and obstructions.
 - Pump does not cycle - Replace pump.
 8. CO₂ is present at the brass CO₂ BIB supply fitting and Step 3 has been addressed the BIB (Product) pump will need to be replaced

STEP MOTOR**Function**

Raises and lowers the blender blade to provide consistent mixing of ingredients.

Specification

5 VDC from Blender Board

Check Procedure

1. Disconnect the connector (MTA4), terminals TP12B, TP13B, TP14A and TP13A on the top of Blender Board. The Blender Board is located on the back of the Blender Assembly. See "Blender Control Board" on page 79.
2. Check for 5 VDC across XXX.
 - Open (OL) = Replace motor.
 - Resistance = Motor windings are good.
3. Check rotor for excessive play or binding.
4. Test home position switch.
5. Test door switch(es).
6. Replace Blender Board.

BLENDER MOTOR**Function**

Mixes ingredients to maintain a consistent product.

Specification

220 V 50 Hz

Check Procedure

Use a voltmeter/ohm meter to check motor operation.

1. Disconnect the Blue and White wires from the Blender motors. Blender Board is located on the back of the Blender Assembly.
 - Check resistance across the blender motor leads.



- Open (OL) = Replace motor.
 - Resistance = 95 ohms motor is good.
2. Check rotor for excessive play or binding.
 3. Test capacitor.
 4. Test home position switch.
 5. Verify relay is closed/powering - if not test door switches.
 6. Replace Blender Board.

HOME POSITION SWITCH**Function**

Prevents blender motor operation if the step motor does not return to the home (up) position.

Specification

SPST Normally Open Switch

Location

On Blender Assembly / Linear Slide bracket. One switch on left side bracket and one switch on the right side bracket.

Check Procedure

Use a voltmeter/ohm meter to check switch operation.

1. Inspect the switch for correct wiring. On Blender Board at J13 Terminal, 1 = Blue Terminal 2 = Brown.
2. Isolate the switch by disconnecting the wiring connectors. On Blender Board at J13 Terminal, 1 = Blue Terminal 2 = Brown.
3. Check continuity across the switch terminals in the open and closed position. Replace the switch if continuity readings do not match both switch settings. On Blender Board at J13 Terminal, 1 = Blue Terminal 2 = Brown.
 - Open (OL) = Replace motor.
 - Resistance (0) = Motor is good.

DOOR SWITCHES**Function**

Prevents blender motor operation if the door/switch is not closed.

Location

Magnetic switch is located on top of the Blend Chamber / Linear Slide Bracket access from the back side. The relay switch is located on each Blender Assembly bracket.

Specification

One (1) Magnetically operated SPST normally open switch per Blender per side. One (1) Relay switch per blender per side.

Check Procedure

Use a voltmeter/ohm meter to check switch operation.

1. Inspect the switch for correct wiring.
2. Isolate the switch by disconnecting the wiring connectors.
3. Check continuity across the switch terminals in the open and closed position.

Remove = (Replace the switch if continuity readings do not match both switch settings.)

- Open (OL) = Replace motor.
- Resistance (0) = Switch is good.

WATER RINSE SOLENOID VALVE**Function**

Opens and closes to control water flow.

Location

The Water Rinse Solenoid Valve is located on each Blender Assembly/Linear Slide bracket.

Specifications

24 VDC

Check ProcedureCONTINUAL WATER FLOW

1. Place power switch in off position.
 - Flow continues - Replace valve.
 - Flow stops - Replace relay board.
2. Turn power switch to the on position.
 - Open blender door.
 - If flow stops relay is good.
 - If flow continues check power to Solenoid coil if 24v is present replace Blender Board.

NO WATER FLOW

1. Verify water is supplied.
2. Energize the water valve.
3. Check for line voltage at valve coil:
 - Line voltage present - Replace water valve.
 - Line voltage not present - Replace relay board.

Refrigerated Cabinet

TEMPERATURE THERMISTOR - NOZZLE, CABINET OR DEFROST

Location

- Nozzle Thermistor - Behind the front fascia inside the duct area connected to the product line.
- Cabinet Thermistor - Attached to the evaporator plate in the base unit.
- Defrost Thermistor - Inserted into the evaporator coil.

Function

Supplies input to the SRB board to indicate nozzle, cabinet or defrost temperature. The SRB board energizes and de-energizes the compressor based on input from the thermistors.

Specifications

5,000 Ohms \pm 2% at 25°C (77°F)

16,330 Ohms \pm 2% at 0°C (32°F)

Check Procedure

NOTE: Use a multimeter to check operation.

1. Reboot machine by moving toggle switch off/on.
2. Inspect for correct wiring on the SRB Board.
 - Nozzle connection terminal J33
 - Cabinet connection terminal J32
 - Defrost connection terminal J34
3. Isolate by disconnecting the wiring connectors.
4. Check continuity across the terminals with an ohm meter.
 - Resistance = Thermistor is good.
 - Open (OL) = Replace thermistor.

NOTE: These thermistors are identical. Swapping the thermistor connections at the SRB board can be used for diagnostics.

Temperature/Resistance Chart

This chart is used for the temperature control thermistors. As the temperature rises at the thermistor block, the resistance drops.

If the ohmmeter reads "OL", check the scale setting on the meter before assuming the thermistor is bad.

°C	°F	OHM
-17.8	0	43,297
-15.0	5	36,503
-12.2	10	30,884
-9.4	15	26,948
-6.7	20	22,928
-3.9	25	20,082
-1.1	30	17,188
1.7	35	14,751
4.4	40	13,019
7.2	45	11,506
10.0	50	9,951

EVAPORATOR FAN MOTOR**Location**

On the top of the evaporator.

Function

Moves cabinet air through the evaporator to maintain cabinet temperature at set point.

Specification

2x evaporator 220V, 50 Hz fan motors.

Check Procedure

1. Check the wiring on the power supply terminal CN2 pins 2&5.
2. Check 230 VAC present at terminal CN2 pins 2&5.
3. If voltage is present follow the below procedures.
4. Isolate by disconnecting the wiring connectors.
5. Check continuity across the terminals with an ohm meter.
 - Resistance = Motor windings are good.
 - Open (OL) = Replace motor.
6. Check rotor for excessive play or binding.

DUCT FAN MOTOR**Location**

Top of the base cabinet below the duct opening.

Function

Moves cool air from the cabinet through the tubing chase to maintain cabinet temperature in the beverage lines.

Specifications

24 VDC 2.4 watt

Check Procedure

1. Check wiring connections on SRB terminal J36.
2. Isolate by disconnecting the wiring connectors.
3. Check continuity across the terminals with an ohm meter.
 - Resistance of $17M\Omega \pm 10\%$ = Motor is good.
 - Open (OL) = Replace motor.
4. Check rotor for excessive play or binding.

CONDENSER FAN MOTOR**Location**

At the rear of the base unit, behind the panels on the condensing unit.

Function

Moves air through the condenser to condense refrigerant from vapor to liquid state.

Specification

230 VAC 9 watts

Check Procedure

1. Isolate by disconnecting the main power supply.
2. Check that the fan blade is secured to the motor.
3. Check the blade spins freely.
4. Check rotor for excessive play or binding.
5. Remove the wiring from the terminal connectors and check continuity across the terminals with an ohm meter.
 - Resistance = Motor windings are good.
 - Open (OL) = Replace motor.

COMPRESSOR DRAWING LOCKED ROTOR

To determine if the compressor is seized, check the amp draw while the compressor is trying to start.

The two likely causes of this are a defective starting component and a mechanically seized compressor.

To determine which you have:

Install high and low side gauges.

Try to start the compressor.

Watch the pressures closely.

If the pressures do not move, the compressor is seized.

Replace the compressor.

If the pressures move, the compressor is turning slowly and is not seized. Check the capacitors and relay.

COMPRESSOR DRAWING HIGH AMPS

The continuous amperage draw on start-up should not be near the maximum fuse size indicated on the serial tag.

DIAGNOSING CAPACITORS

If the compressor attempts to start, or hums and trips the overload protector, check the starting components before replacing the compressor.

Visual evidence of capacitor failure can include a bulged terminal end or a ruptured membrane. Do not assume a capacitor is good if no visual evidence is present.

Use a capacitor tester when checking a suspect capacitor. Clip the bleed resistor off the capacitor terminals before testing.

If the compressor hums and will not start but the windings are good. Replace the start capacitor.

A good test is to install a known good substitute capacitor.

Filter-Driers**Location**

Cabinet: between compressor and condenser coil.

Function

To remove moisture and particulates from the refrigerant. This will prevent premature failure of the compressor and blocking of restrictor devices.

Specification

The size of the filter-drier is important due to a critical refrigerant charge. Using an improperly sized filter-drier will cause the refrigeration system to be improperly charged with refrigerant.

Driers are covered as a warranty part. The drier must be replaced any time the system is opened for repairs. Refer to the parts manual for the recommended OEM field replacement drier.

Check Procedure

The drier should not alter the temperature of the refrigerant. Compare the temperature of the copper pipe either side of the filter/drier, they should be the same.

If there is a temperature drop that indicates a partial blockage of the filter/drier and it should be replaced.

THIS PAGE INTENTIONALLY LEFT BLANK

Section 8 Charts

Total System Refrigerant Charge

This information is for reference only. Refer to the Blend-In-Cup Beverage System model/serial number tag to verify the system charge. Serial plate information overrides information listed on these pages.

⚠ Warning

Refrigerant type and amount varies by model. Always refer to model/serial plate to identify refrigerant type and amount.

Important

Due to continuous improvements, this information is for reference only. Please refer to the serial number tag to verify electrical data. Serial tag information overrides information listed on this page.

Model	Base (System 1)
MA-8-2, MA-8-2BF, MA-8-2AF	12 oz (339 g)

Nominal Operating Voltage

NOMINAL OPERATING VOLTAGE FOR LOADED ELECTRICAL COMPONENTS

Component	High Voltage AC	24V DC Voltage	Low Voltage AC	Modbus	Other
Evaporator Fan, Refrigerator Base	X				
Evaporator Fan, Duct		X			
Condenser Fan, Refrigerator Base	X				
Compressor, Refrigerator Base	X				
Mixer/Blender, Linear Motor, Rotation Motor	X	X	X		
Product Solenoid Valve, Refrigerator Base		X			
CO ₂ /Air Solenoid Valve		X			
Water Solenoid Valve, Plain,		X			
Relay	X	X			
Power Supply - High Voltage to 24V DC Transformer	X	X (OUT)			
UI Assembly (Board, Touchpad)		X		X	
Mixer/Blender Board Assembly	X	X		X	
SRB Assembly, Control Board to All Components	X	X	X	X	X

NOTE: Voltage into Load Component except as noted. High Voltage AC - Refer to Nameplate Rating. Low Voltage AC - Less than 10V AC. Other - Refer to Tech Manual for details.

NOMINAL OPERATING VOLTAGE FOR SENSORS

Component	High Voltage AC	24V DC Voltage	Low Voltage AC	Modbus	Other
Temperature - Drive, Defrost, Nozzle, Cabinet			X		X
Ice Position Dispense Wheel		X			
Mixer/Blender, Limit Switches		X	X		
High Pressure Switch - Refrigeration		X			
Mixer/Blender Door Switches		X			

NOTES: Voltage into Load Component except as noted. High Voltage AC - Refer to Nameplate Rating. Low Voltage AC - Less than 10V AC. Other - Refer to Tech Manual for details.

Section 9 Diagrams

Wiring & Plumbing Diagrams

The following pages contain electrical wiring and plumbing diagrams. Be sure you are referring to the correct diagram for the Blend-In-Cup Beverage System you are servicing

Warning

Always disconnect power before working on electrical circuitry.

LOWER REFRIGERATION CABINET WIRING DIAGRAM

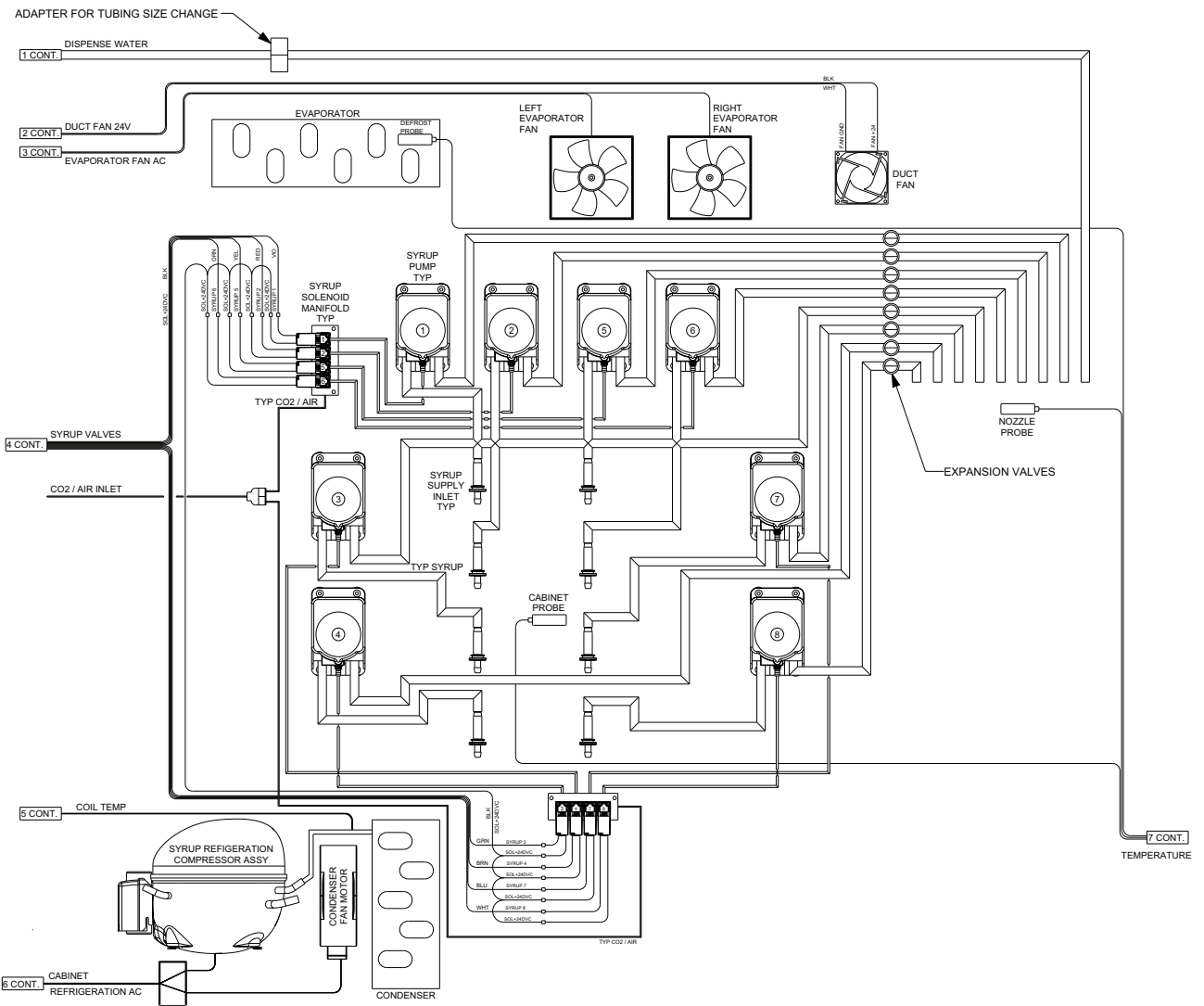

SHAVER MOTOR & HARNESS WIRING

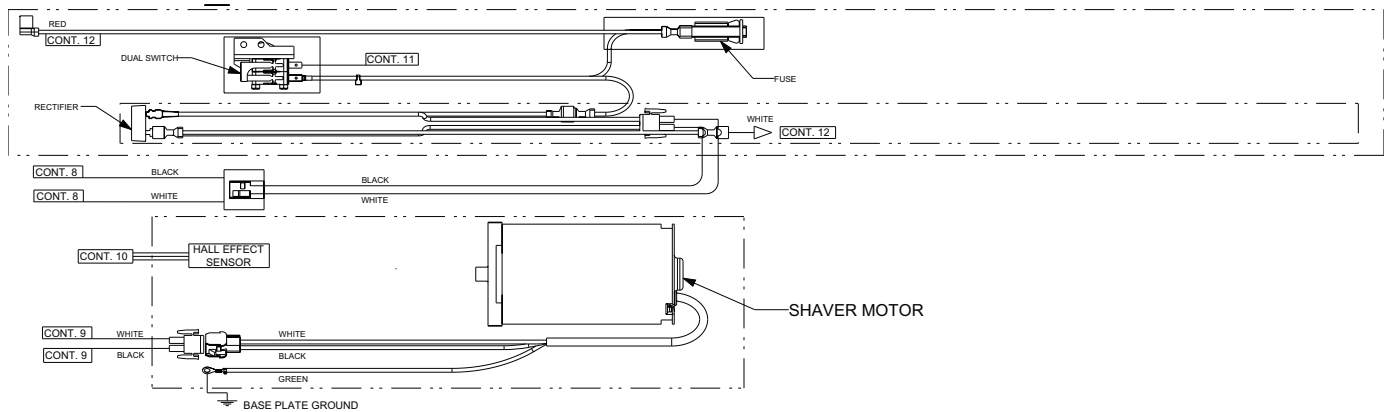

LOWER REFRIGERATION CABINET PLUMBING DIAGRAM

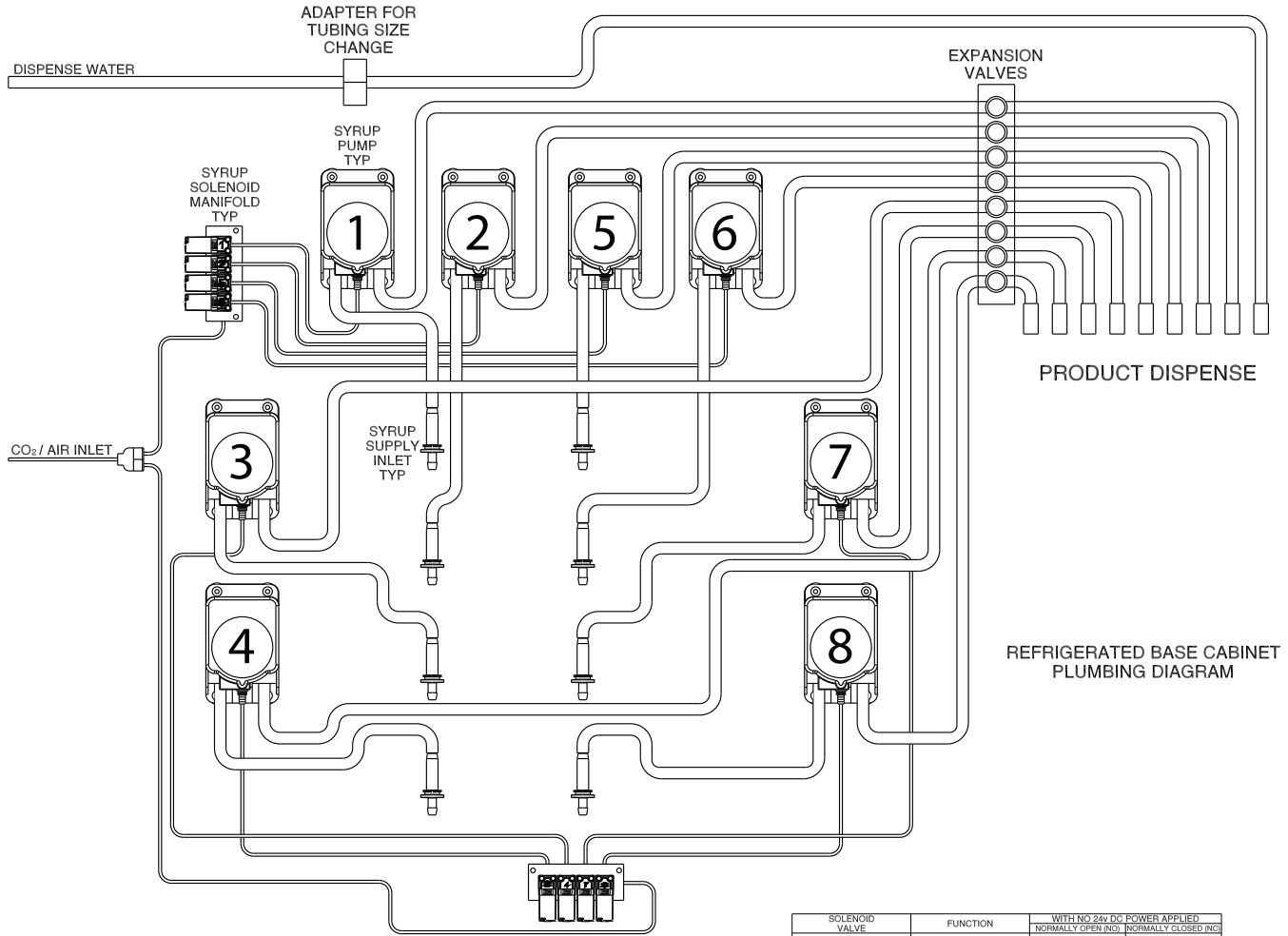

SOLENOID VALVE	FUNCTION	WITH NO 24V DC POWER APPLIED	
		NORMALLY OPEN (NO)	NORMALLY CLOSED (NC)
BLENDER RINSE #1 & #2	RINSE WATER INLET		X
SYRUP #1 THRU #8	CO ₂ INLET TO SYRUP PUMPS		X

PRODUCT PLUMBING & LMS VALVE LAYOUT

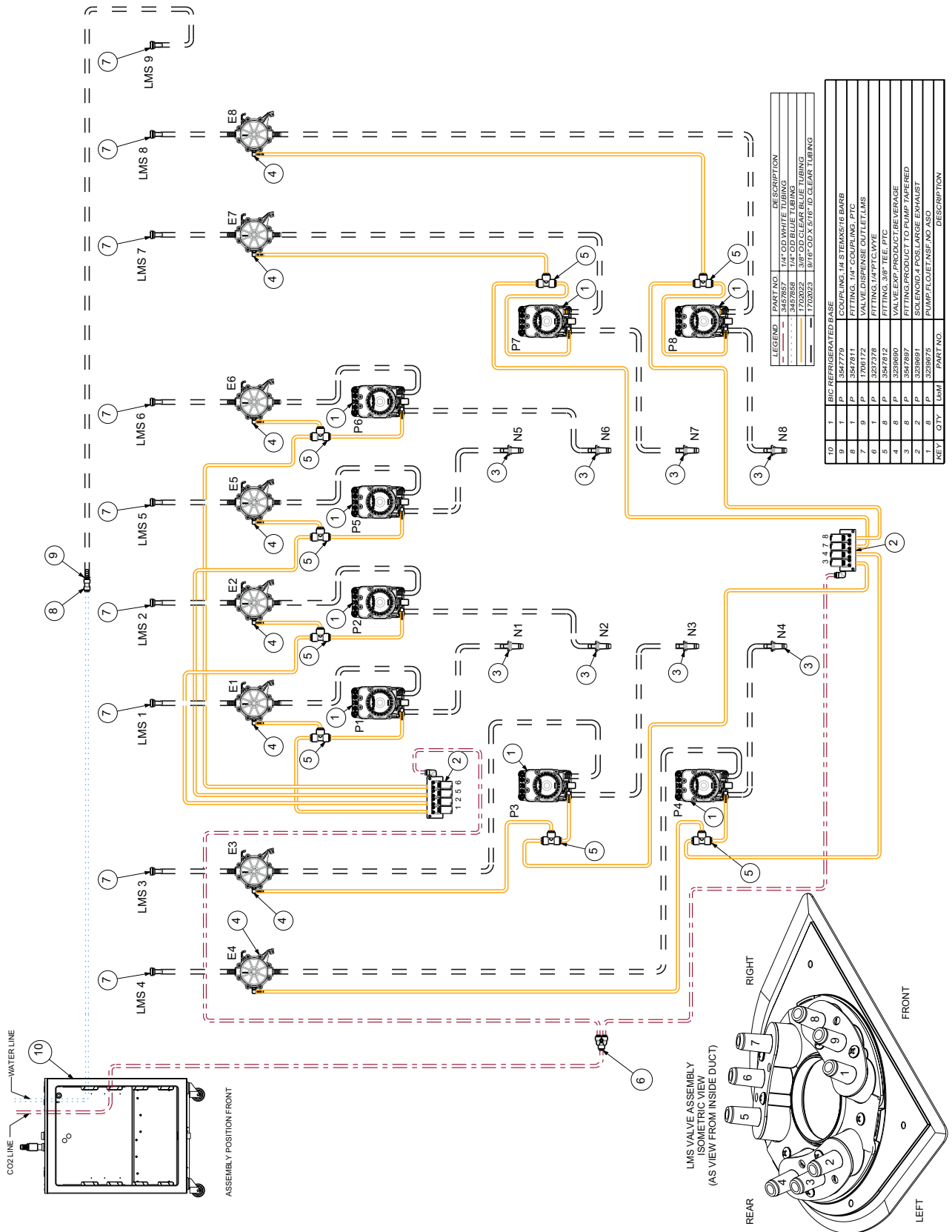

DISPENSE SYSTEM DIAGRAM

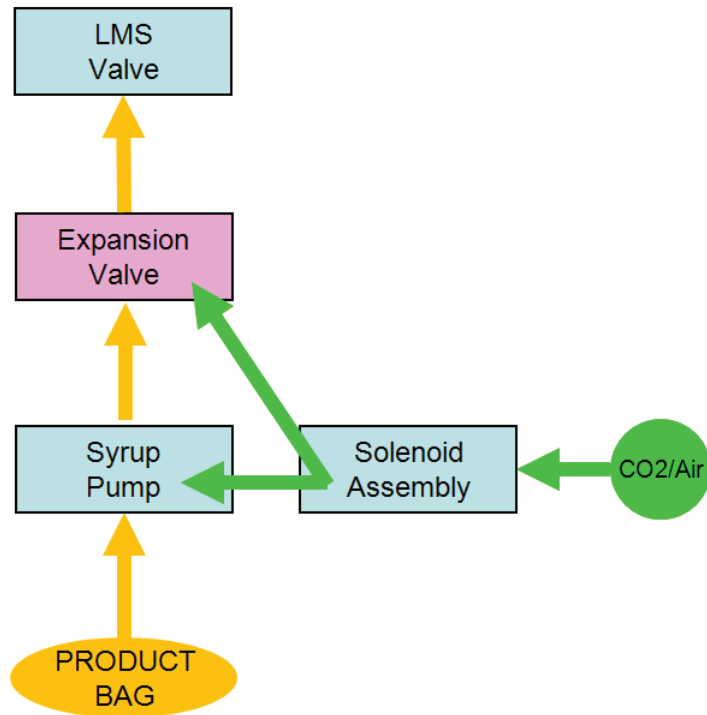

Expansion Valve

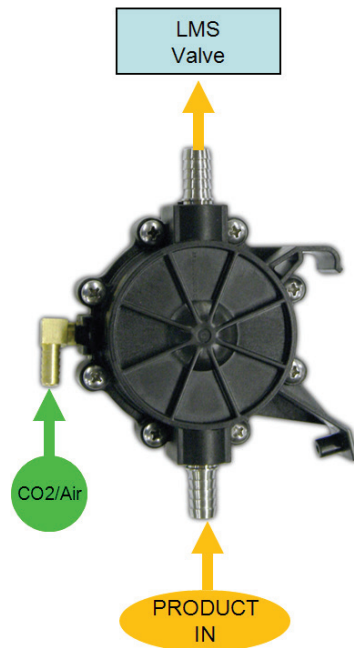



MULTIPLEX
2100 FUTURE, SELLERSBURG, IN 47172

800-367-4233
WWW.MANITOWOCBEVERAGE.COM/US

Every new piece of Manitowoc Foodservice equipment comes with KitchenCare™ and you choose the level of service that meets your operational needs from one restaurant to multiple locations.

StarCare – Warranty & lifetime service, certified OEM parts, global parts inventory, performance audited

ExtraCare – CareCode, 24/7 Support, online/mobile product information

LifeCare – Install & equipment orientation, planned maintenance, KitchenConnect™, MenuConnect

Talk with KitchenCare™ • 1-844-724-CARE • www.mtwkitchencare.com



To learn how Manitowoc Foodservice and its leading brands can equip you, visit our global web site at www.manitowocfoodservice.com, then discover the regional or local resources available to you.

