



MD/MDH SERIES

MD 150/175/200/250 & MDH 302/402 Beverage/Ice Dispensers

INSTALLATION & SERVICE GUIDE

Part Number 5010330



ISO 9001:2015
Quality System Certified

Multiplex

645 Park East Blvd, Suite 5 • New Albany, IN 47150
Tel: 844.724.2273 • Fax: 812.246.7020
www.multiplexbeverage.com

In accordance with our policy of continuous product development and improvement, this information is subject to change at any time without notice.

December 03, 2007 REV5

FOREWORD

Multiplex developed this manual as a reference guide for the owner/operator, service agent, and installer of this equipment. Please read this manual before installation or operation of the machine. A qualified service technician should perform installation and start-up of this equipment, consult the *Troubleshooting Guide* within this manual for service assistance.

If you cannot correct the service problem, call your Multiplex Service Agent or Distributor. Always have your model and serial number available when you call.

Your Service Agent _____

Service Agent Telephone Number _____

Your Local Multiplex Distributor _____

Distributor Telephone Number _____

Model Number _____

Serial Number _____

Installation Date _____

UNPACKING AND INSPECTION

Note: The dispenser was thoroughly inspected before leaving the factory. Any damage or irregularities should be noted at the time of delivery.

WARRANTY INFORMATION

Consult your local Multiplex Distributor for terms and conditions of your warranty. Your warranty specifically excludes all beverage valve brixing, general adjustments, cleaning, accessories and related servicing.

Your warranty card must be returned to Multiplex to activate the warranty on this equipment. If a warranty card is not returned, the warranty period can begin when the equipment leaves the Multiplex factory.

No equipment may be returned to Multiplex without a written Return Materials Authorization (RMA). Equipment returned without an RMA will be refused at Multiplex's dock and returned to the sender at the sender's expense.

Please contact your local Multiplex distributor for return procedures.

TABLE OF CONTENTS

FOREWORD	2
UNPACKING AND INSPECTION	2
WARRANTY INFORMATION	2
SAFETY	6
IMPORTANT SAFETY INSTRUCTIONS	6
CARBON DIOXIDE WARNING	6
QUALIFIED SERVICE PERSONNEL	6
SHIPPING, STORAGE, AND RELOCATION	6
ADDITIONAL WARNINGS	6
GROUNDING INSTRUCTIONS	7
INSTALLATION	8
PRE-INSTALLATION CHECK LIST	8
LEGS	8
UNIT INSTALLATION	9
DRAINAGE OPTIONS	9
CARB TANK PURGE TUBE ROUTING	10
COLD CARB AND AMBIENT SYSTEM PRESSURES	11
AMBIENT BAG-IN-BOX (B-I-B) SYSTEM	11
COLD CARB BAG-IN-BOX (B-I-B) SYSTEM	11
TOP MOUNTED ICEMAKER REQUIREMENTS	13
ICE FLOW RESTRICTOR	13
BAFFLE FOR MANITOWOC™ CUBERS	14
BAFFLE FOR "Q" SERIES ICE MACHINES	14
MANUAL FILL LID FOR DISPENSERS WITH A CUBER	14
PLUMBING DIAGRAM LOCATION	15
MD-150 6 VALVE PLUMBING DIAGRAM	16
MD-150 6 VALVE FLEX MANIFOLD	16
MD-175 8 VALVE PLUMBING DIAGRAM	17
MD-175 8 VALVE FLEX MANIFOLD	17
MD-200/250 8 VALVE PLUMBING DIAGRAM	18
MD-200/250 8 VALVE FLEX MANIFOLD	18
MD-200/250 10 VALVE PLUMBING DIAGRAM	19
MD-200/250 10 VALVE FLEX MANIFOLD	19
MD-302 12 VALVE PLUMBING DIAGRAM	20
MD-302 12 VALVE FLEX MANIFOLD	20
MD-402 16 VALVE PLUMBING DIAGRAMS	21
MD-402 16 VALVE FLEX MANIFOLD	21
MD-402 20 VALVE PLUMBING DIAGRAMS	22
MD-402 20 VALVE FLEX MANIFOLD	22

TABLE OF CONTENTS

OPERATION	23
UNIT INSPECTION	23
ICE STORAGE AND DISPENSING	23
ROCKING CHUTE ICE DISPENSING	23
COLD PLATE BEVERAGE COOLING	23
BEVERAGE VALVES	23
AUTO BAG SELECTORS	24
B-I-B	24
PUMPS	24
RACKING	24
PRE-MIX & POST-MIX BEVERAGE DISPENSERS	24
BACK ROOM PACKAGE	25
BAG-IN-BOX SYSTEM	25
FIGAL SYSTEM	26
CARBONATION	27
INTERNAL CARBONATION	27
MD SERIES COUNTERTOP MEASUREMENTS	28
MD SERIES SPECIFICATIONS	29
MDH SERIES COUNTERTOP MEASUREMENTS	30
MDH SERIES SPECIFICATIONS	31
ROCKING CHUTE ICE DELIVERY SWITCH ADJUSTMENT	32
SETTING THE AUTOMATIC AGITATION TIMER	33
115V/220V NON ADJUSTABLE AGITATION TIMER	33
SEQUENCE OF OPERATION	34
USER MAINTENANCE	35
PREVENTATIVE MAINTENANCE	35
HOW TO DISASSEMBLE FOR CLEANING OR MAINTENANCE	35
DAILY CLEANING	38
MONTHLY CLEANING	39
BEVERAGE SYSTEM CLEANING	40
BAG-IN-BOX SYSTEM	40
FIGAL BEVERAGE SYSTEM	41

TABLE OF CONTENTS

EXPLODED VIEWS, PARTS & DIAGRAMS	42
MD 150/175/200/250 EXPLODED VIEW	42
MD 150 PARTS LIST	43
MD 175 PARTS LIST	43
MD 200/250 PARTS LIST	44
MDH 302/402 EXPLODED VIEW	45
MDH 302 PARTS LIST	46
MDH 402 PARTS LIST	46
MD 150 115V PRE-MIX WIRING DIAGRAM	47
MD 150/175/200 115V WIRING DIAGRAM	48
MD 150 220V PRE-MIX WIRING DIAGRAM	49
MD 150/175/200 220V WIRING DIAGRAM	50
MD 250 115V WIRING DIAGRAM	51
MD 250 220V WIRING DIAGRAM	52
MDH 302 115V WIRING DIAGRAM	53
MDH 302 220V WIRING HARNESS	54
MDH 402 115V WIRING DIAGRAM	55
MDH 402 220V WIRING DIAGRAM	56
TROUBLESHOOTING	57
PUMP	57
DRINKS	58
LIQUID LEVEL CONTROL	60
INDEX	63

SAFETY

IMPORTANT SAFETY INSTRUCTIONS

Carefully read all safety messages in this manual. Learn how to operate the MD unit properly. Do not allow anyone to operate the unit without proper training and keep it in proper working condition. Unauthorized modifications to the MD may impair function and/or safety and affect the life of the unit.

CARBON DIOXIDE WARNING



DANGER: Carbon Dioxide (CO_2) displaces oxygen. Exposure to a high concentration of CO_2 gas causes tremors, which are followed rapidly by loss of consciousness and suffocation. If a CO_2 gas leak is suspected, particularly in a small area, immediately ventilate the area before repairing the leak. CO_2 lines and pumps should not be installed in an enclosed space. An enclosed space can be a cooler or small room or closet. This may include convenience stores with glass door self serve coolers. If you suspect CO_2 may build up in an area, venting of the B-I-B pumps and / or CO_2 monitors should be utilized.

QUALIFIED SERVICE PERSONNEL



WARNING: Only trained and certified electrical and plumbing technicians should service this unit. All wiring and plumbing must conform to national and local codes.

SHIPPING, STORAGE, AND RELOCATION



CAUTION: Before shipping, storing, or relocating this unit, syrup systems must be sanitized. After sanitizing, all liquids (sanitizing solution and water) must be purged from the unit. A freezing environment causes residual sanitizing solution or water remaining inside the unit to freeze, resulting in damage to internal components.

ADDITIONAL WARNINGS

	CAUTION Unplug unit before servicing or cleaning ice bin. Ice bin contains parts that can move at any time and will cause injury if hands are in the way.
--	--

WARNING Flush sanitizing solution from syrup system Residual sanitizing solution left in system could create a health hazard

	WARNING When using cleaning fluids or chemicals, rubber gloves and eye protection should be worn
--	--

	WARNING UNPLUG UNIT BEFORE SERVICING OR CLEANING ELECTRIC SHOCK HAZARD
--	---

Installation and start-up of this equipment should be done by a qualified service technician. Operation, maintenance, and cleaning information in this manual are provided for the user/operator of the equipment. **Save these instructions.**

SAFETY

GROUNDING INSTRUCTIONS



WARNING: Risk of electrical shock. Connect to a properly grounded outlet only.

This appliance must be grounded. In the event of malfunction or breakdown, grounding provides a path of least resistance for electric current to reduce the risk of electric shock. This appliance is equipped with a cord having an equipment-grounding conductor and a grounding plug. The plug must be plugged into an appropriate outlet that is properly installed and grounded in accordance with all local codes and ordinances.

DANGER – Improper connection of the equipment-grounding conductor can result in a risk of electric shock. The conductor with insulation having an outer surface that is green with or without yellow stripes is the equipment grounding conductor. If repair or replacement of the cord or plug is necessary, do not connect the equipment-grounding conductor to a live terminal. Check with a qualified electrician or serviceman if the grounding instructions are not completely understood, or if in doubt as to whether the appliance is properly grounded. Do not modify the plug provided with the appliance – if it will not fit the outlet, have a proper outlet installed by a qualified electrician.

WARNING – When using electric appliances, basic precautions should always be followed, including the following:

- a) Read all the instructions before using the appliance.
- b) To reduce the risk of injury, close supervision is necessary when an appliance is used near children.
- c) Do not contact moving parts.
- d) Only use attachments recommended or sold by the manufacturer.
- e) Do not use outdoors.
- f) For a cord-connected appliance, the following shall be included:
 - Do not unplug by pulling on cord. To unplug, grasp the plug, not the cord.
 - Unplug from outlet when not in use and before servicing or cleaning.
 - Do not operate any appliance with a damaged cord or plug, or after the appliance malfunctions or is dropped or damaged in any manner. Return appliance to the nearest authorized service facility for examination, repair, or electrical or mechanical adjustment.
- g) For a permanently connected appliance – Turn the power switch to the off position when the appliance is not in use and before servicing or cleaning.
- h) For an appliance with a replaceable lamp – always unplug before replacing the lamp. Replace the bulb with the same type.
- i) For a grounded appliance – Connect to a properly grounded outlet only. See Grounding Instructions.

SAVE THESE INSTRUCTIONS

INSTALLATION

PRE-INSTALLATION CHECK LIST

When installing any system, first make sure the major components are available. Generally the major components necessary for an installation are:

- Do you have enough space to install the dispenser or a dispenser and top mounted cuber?
- Does the top mounted cuber (if utilized) have a minimum of 6 inches (15.3 cm) clearance on all sides?
- Is the countertop level?
- Can the countertop support the weight of the dispenser, or the dispenser/cuber combination plus the weight of the stored ice?

Pre-mix system:

- CO₂ regulator set
- Product connectors for Figal tank
- Gas connectors for Figal tank
- Beverage dispenser
- Beverage tubing
- CO₂ tank
- Figal beverage tanks
- Stepless (Oetiker) clamps
- Chain for CO₂ tank

B-I-B System also:

- B-I-B connectors
- B-I-B regulator set
- B-I-B rack
- B-I-B syrup boxes

Double Check:

- Do you have enough space to install the dispenser or a dispenser and top mounted cuber?
- Does the top mounted cuber (if utilized) have a minimum of 6 inches (15.3 cm) clearance on all sides?

Post mix system:

- CO₂ regulator set
- Beverage dispenser
- Beverage tubing
- CO₂ tank
- Carbonator
- Stepless (Oetiker) clamps
- Chain for CO₂ tank

Figal system also:

- Syrup connectors for Figal tank
- Gas connectors for Figal tank
- Figal syrup tanks

Also consider the location of the following items before installation:

- Water line
- Drain
- Power outlet
- Heating and air conditioning ducts

LEGS



CAUTION: *It is recommended if an icemaker is installed on top of the dispenser, legs should **NOT** be installed.*

Legs are optional equipment with most Servend dispensers. Standard legs are four-inch (10.2 cm) tall painted steel legs.

When installing legs on a MD Series dispenser, leg braces should be used. These are metal braces fitting side to side under the dispenser that reinforce the leg attachment area.

INSTALLATION

UNIT INSTALLATION

1. Place the dispenser in the desired location.
2. Run the beverage lines and water lines (make sure to install the water connections to the proper inlets. Connection "A" comes from the procon pump and is your carbonated water supply and Connection "B" is your plain water supply. (Refer to plumbing diagrams.)
3. Install drain plumbing and insulate.
(See Drainage Options below)
4. Set flexible manifold for correct drink settings.
5. Turn water supply on to the dispenser. Water pressure should be between 40 and 55 psi. If not in-between those pressures proper measures must be taken to regulate them to correct settings.
6. Turn CO₂ supply on to the dispenser. Each cold carb pump deck is furnished with a fixed regulator set at 75 psi. Ambient units need to be set between 90 and 100 psi.
7. Fill bin with ice.
8. Connect power supply.
9. Brix beverage valves.
10. Meet all code requirements.

DRAINAGE OPTIONS

The drains for MD Series connects to the drain pan.

Option One

Drainage through the bottom of the unit:

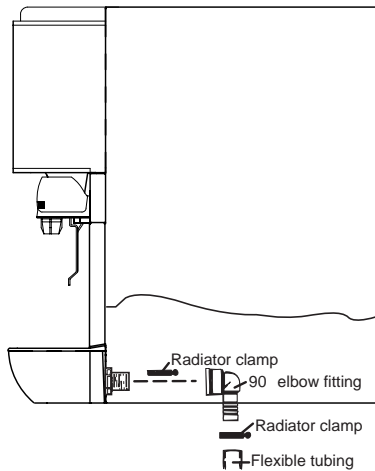

Option Two

Drainage through the back of the unit:

NOTE: The MDH 302 & 402 will have two drains

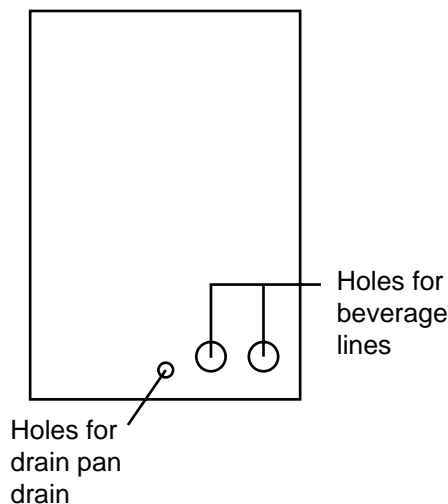
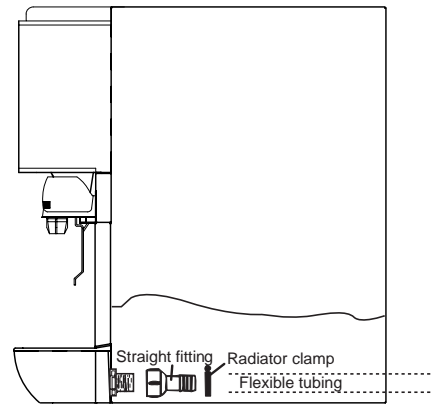

INSTALLATION

CARB TANK PURGE TUBE ROUTING

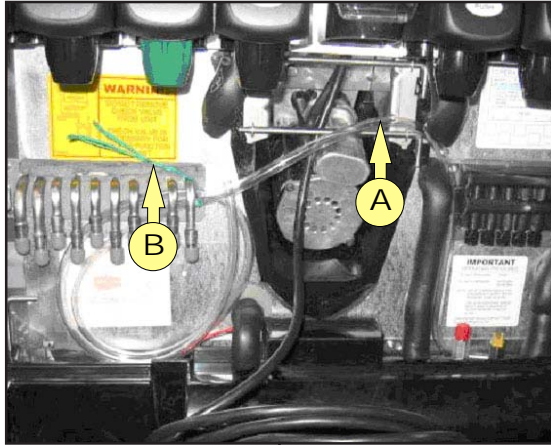

1. During installation of unit the carbonator tank purge tube (A) must be properly routed to a drain. Once the splash panel has been removed from unit remove twist tie (B) that holds carbonator tank purge tube.

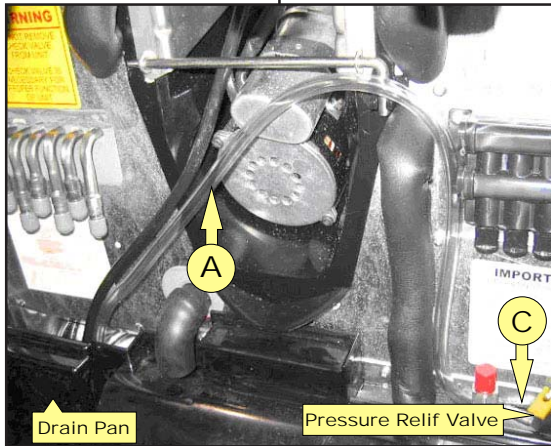

2. Route carbonator tank purge tube (A) down front of unit and behind drain pan. Be sure not to collapse or kink carbonator tank purge tube during routing from unit to drain. (C) Purge tube is connected to the pressure relief valve on carbonator tank and must be routed to a drain

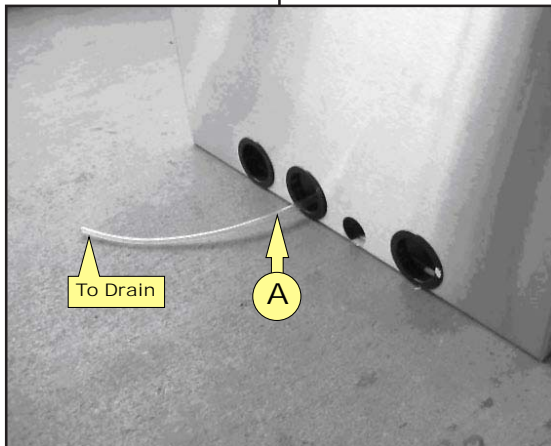

3. The carbonator tank purge tube (A) can be routed down through the counter top that unit has been installed on or out the rear of unit. Then install carbonator tank purge tube to a drain. Follow all local and national plumbing codes when routing carbonator tank purge tube to the drain.

INSTALLATION

COLD CARB AND AMBIENT SYSTEM PRESSURES

- Incoming tap water should be at a minimum pressure of 40 psi and a maximum of 55psi.
- BIB pressure gauge set for 60 psi.
- Carbonator Pressure gauge:
 - Cold Carbonation set for 75 psi.
 - Ambient systems should be set at 90 psi to 100 psi.

NOTE: If incoming water pressure is under 40 psi, a water booster is recommended. If incoming water pressure is over 55 psi, a water regulating valve is required.

AMBIENT BAG-IN-BOX (B-I-B) SYSTEM

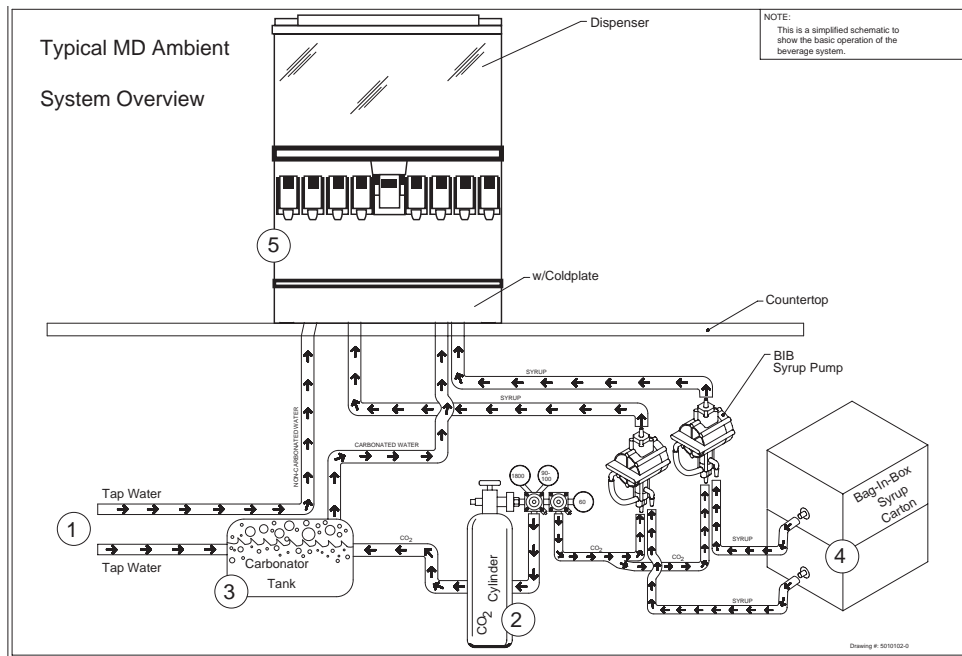

COLD CARB BAG-IN-BOX (B-I-B) SYSTEM

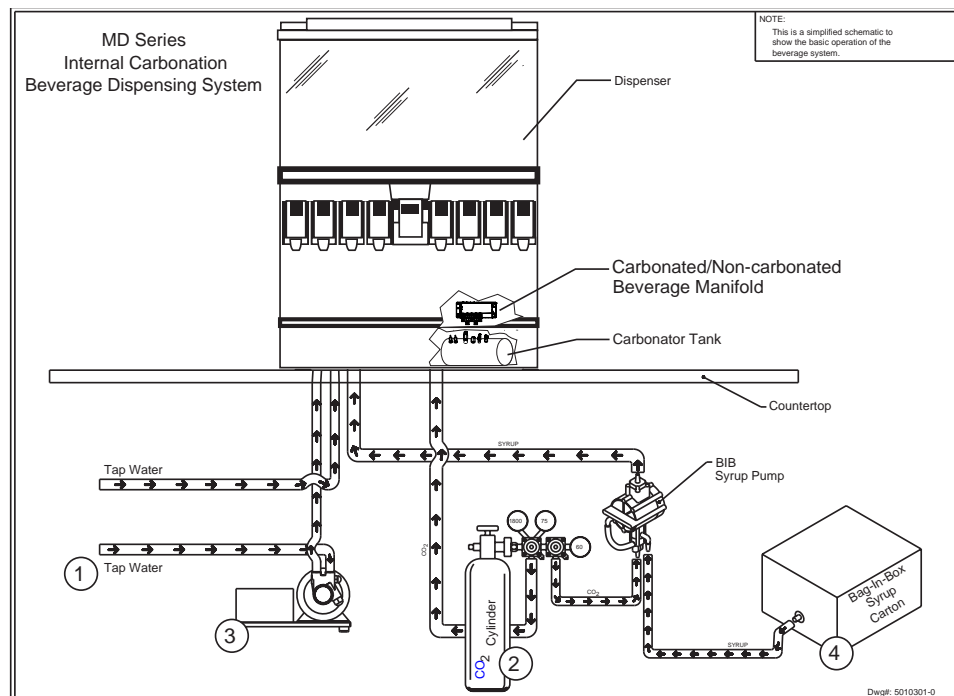

INSTALLATION

COLD CARB BAG-IN-BOX (B-I-B) SYSTEM

MDH-402 COLD CARBONATION INSTALLATION DIAGRAM

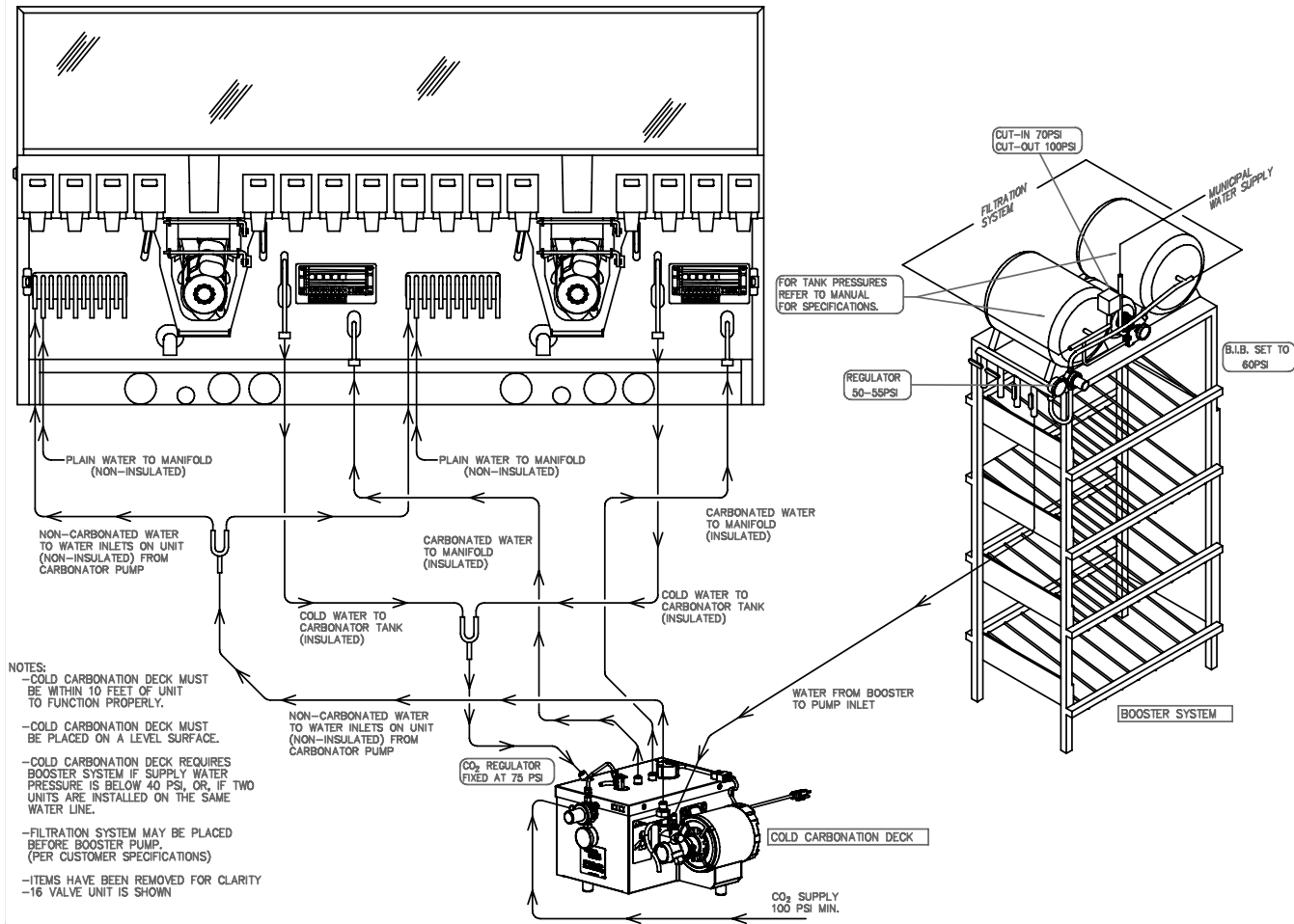

DWG. NO. 5010863-2

INSTALLATION

TOP MOUNTED ICEMAKER REQUIREMENTS

- 1 Location** - Avoid placing the dispenser and/or ice machine near heat sources such as radiators, ovens, refrigeration equipment and direct sunlight.
- 2 Clearances** - Six inch (15.2 cm) clearance on all sides of the icemaker is needed.
- 3 Front of icemaker to be flush with front of dispenser**- The front of the icemaker should be flush with the front of the dispenser, as shown in the drawing above. Because the icemaker is flush with the front of the dispenser, some icemakers may overhang at the back of the dispenser.
- 4 Drains** - A separate drain line is required for the ice machine, in addition to a drain line for the ice/beverage dispenser.
- 5 MD Series dispensers require an adapter kit to install a top-mounted icemaker.** Contact your local Servend distributor for the correct adapter kit.

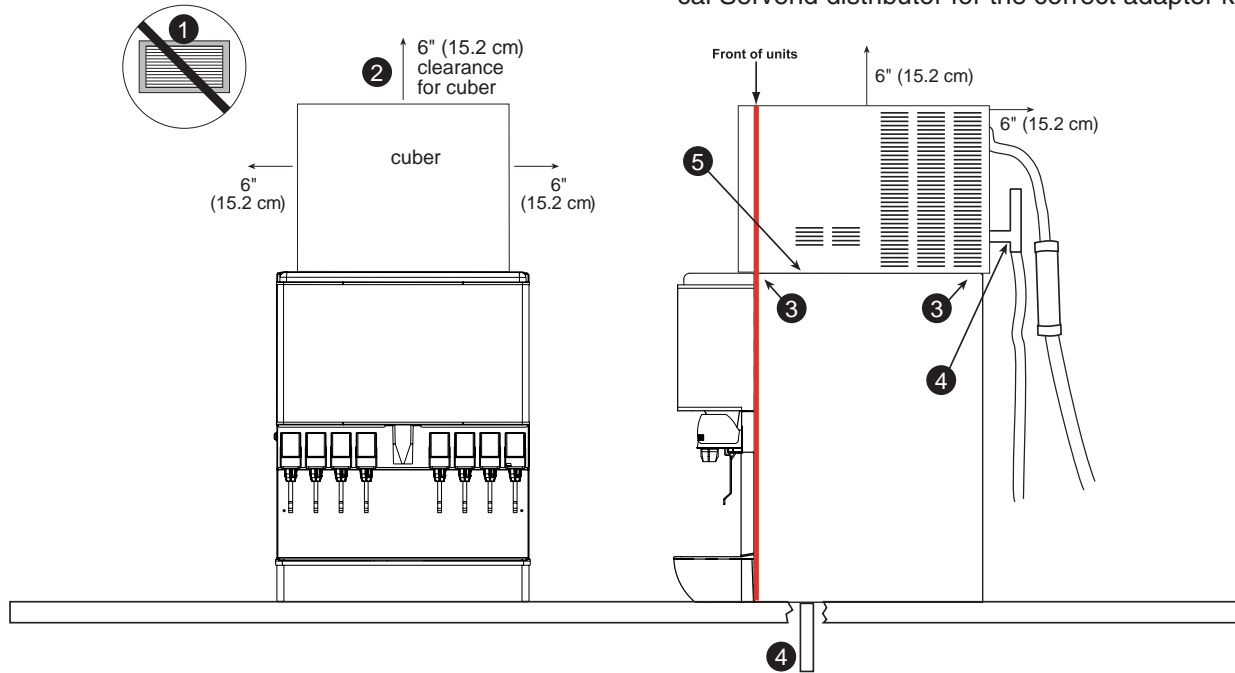

NOTE: For full information about icemaker installation, including plumbing lines connections and electrical requirements, see the icemaker installation manual.

ICE FLOW RESTRICTOR



Ice Flow Restrictor

For all Servend MD/MDH Series dispensers an ice flow restrictor is available. This ice flow restrictor decreases the amount of ice allowed to enter the ice chute by blocking a small area at the entrance of the dispenser chute. This in turn restricts the flow of ice that is dispensed in to your cup.

Please refer to the instructions included in kit #5013822 for more information on how to install.

INSTALLATION

BAFFLE FOR MANITOWOC™ CUBERS

When installing a Manitowoc™ “S” series Ice Machine on a Servend MD-series dispenser, a baffle kit is required for proper installation. The baffle kit is designed to prevent ice from lying against the front of the ice machine, and melting down the front of the dispenser. There are two different baffle kits available from Servend. One kit is for the 30" wide “S” series ice machine, and the other kit is for the 22" wide “S” series ice machine.

These two Kits are available through your local Manitowoc Distributor. List prices may be subject to change without notification. Please call your local parts distributor for current pricing before ordering.

Ice Maker Baffle Installation:

1. Remove both front panels.
2. Examine the ice machine to see if the machine has four screws on the lower front plastic panels.
3. If there are screws, remove them from the countersunk holes on the front surface of the machine, save the screws.
4. Install the deflector, using the four screws removed in step three.
5. Four screws and two backing plates are in the kit.
6. If there are no screws on the ice machine (step 2), pierce the thin plastic countersunk holes, install the backing plates and install the deflector using the screws from the kit.
7. Replace the front panels.

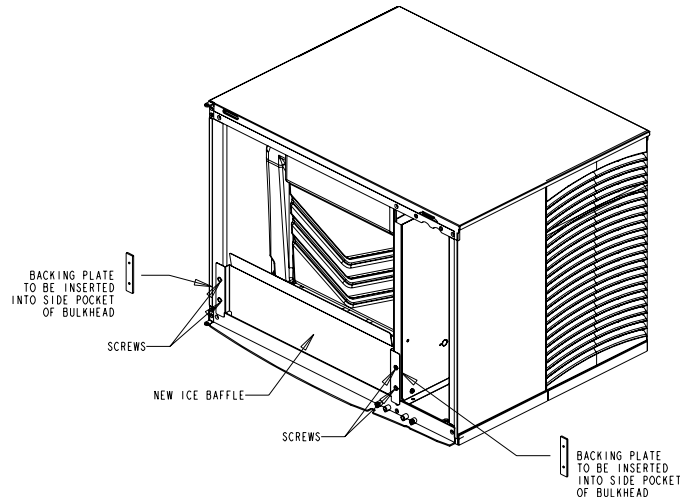

Part Number	Description
5029518	Baffle Kit 30"
5029517	Baffle Kit 22"

BAFFLE FOR "Q" SERIES ICE MACHINES

1. Position baffle on top of water well with tab on the front and the other tab inside the water well.
2. Mount the baffle on the left side of the ice maker using the hole and screw provided.

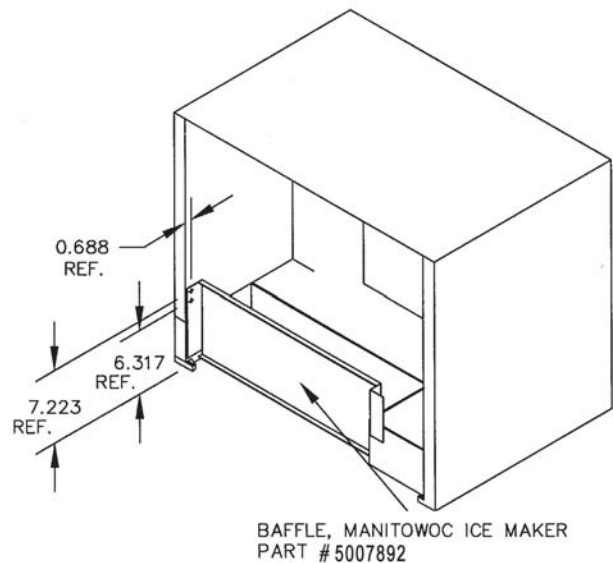

MANUAL FILL LID FOR DISPENSERS WITH A CUBER

If you are top mounting your MD Series dispenser with a cuber, you will require a lid for the manual fill area at the top, front of the dispenser.

If you ordered a Servend dispenser and a cuber at the same time, the manual fill lid was included with the unit. The manual fill lid can be ordered from your local Servend distributor.

INSTALLATION

PLUMBING DIAGRAM LOCATION

The plumbing diagram is printed on a white vinyl label, usually located above the inlet tubes for syrup and later. The plumbing diagram label can be accessed by removing the splash panel of the dispenser. The plumbing diagram label explains which inlet coldplate fittings supply which dispenser valves and water manifolds.

On internal carb units the water supply must first be connected to the carbonator pump before plumbing to connection "A" shown on plumbing diagram. The carbonator pump deck must be within six feet of the dispenser for optimum performance. (See BIB installation diagram for system pressure settings). 0

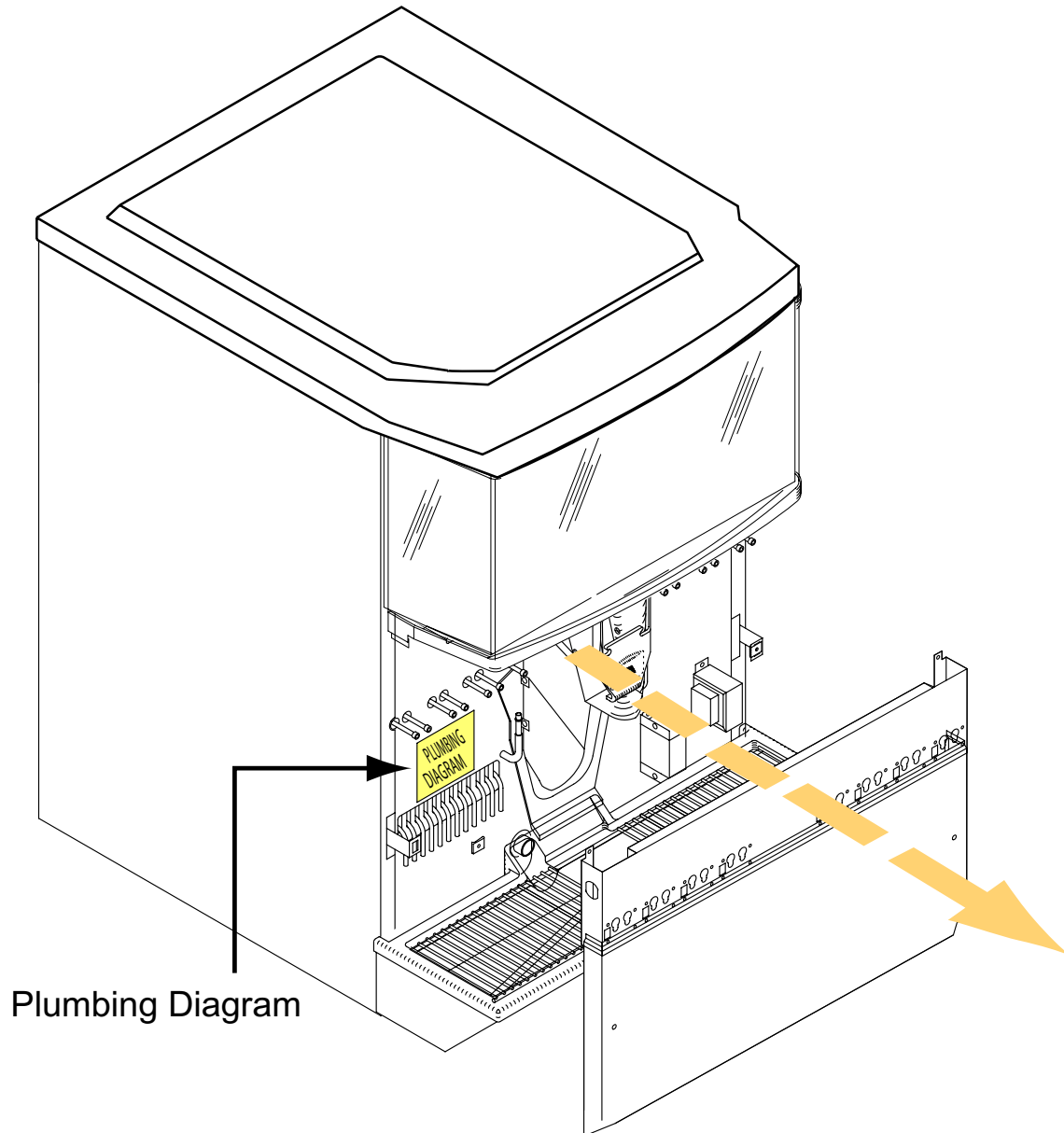

INSTALLATION

MD-150 6 VALVE PLUMBING DIAGRAM

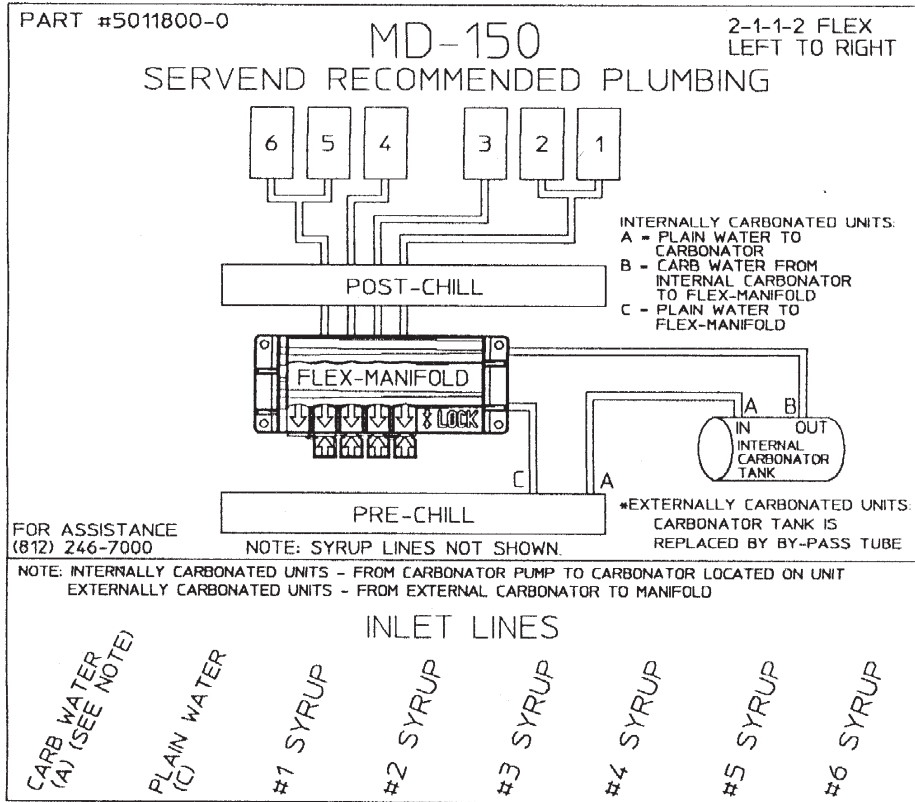

MD-150 6 VALVE FLEX MANIFOLD

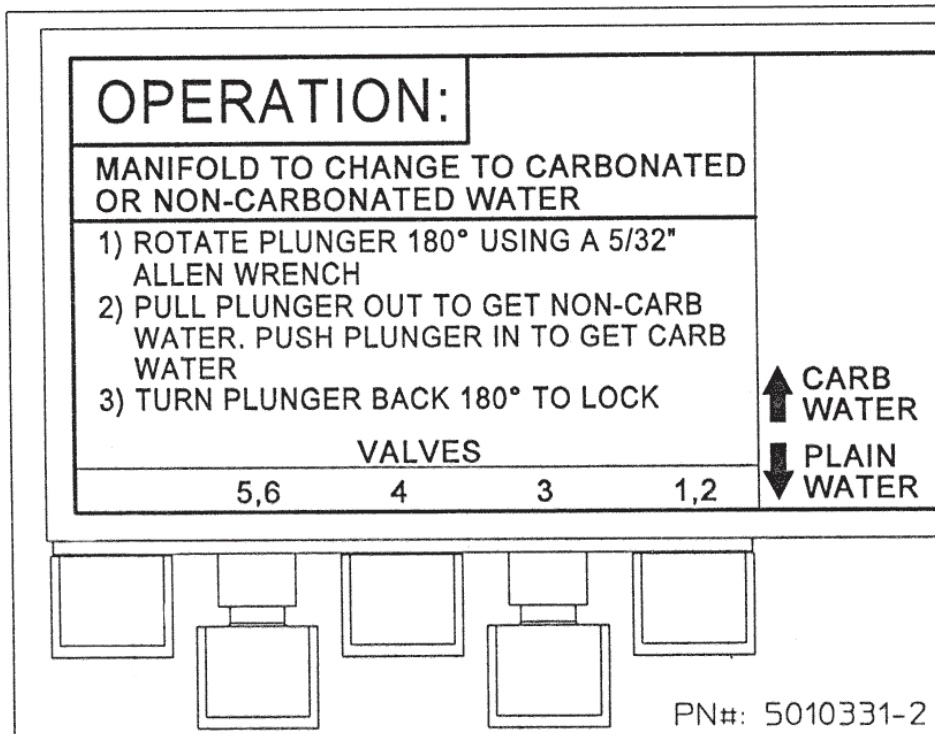

INSTALLATION

MD-175 8 VALVE PLUMBING DIAGRAM

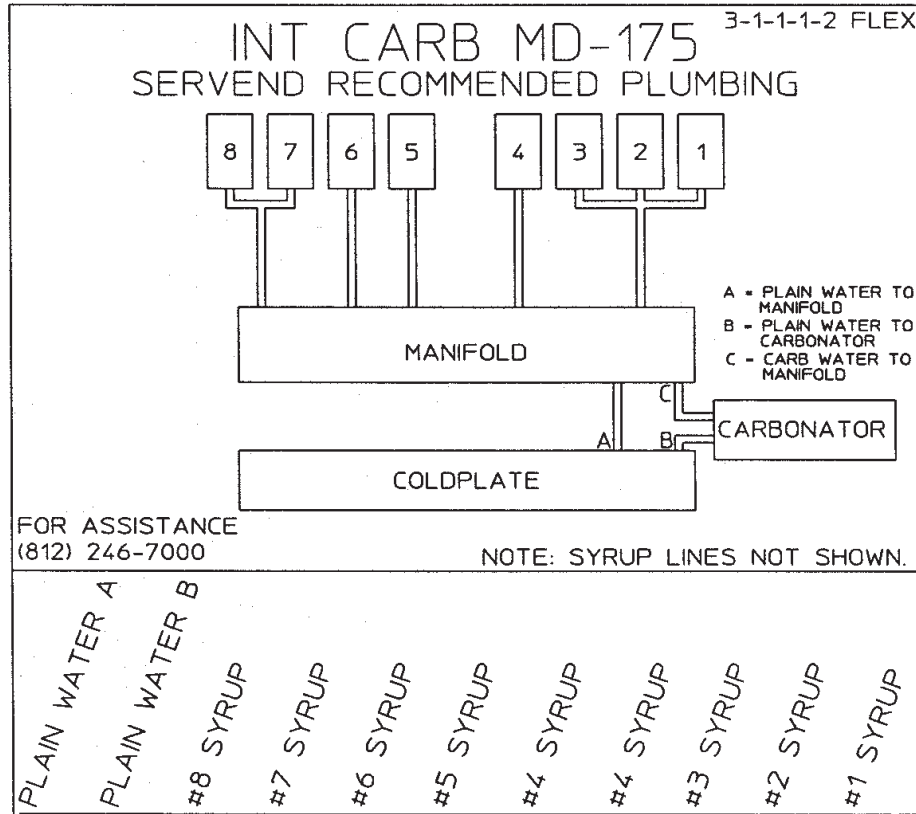

MD-175 8 VALVE FLEX MANIFOLD

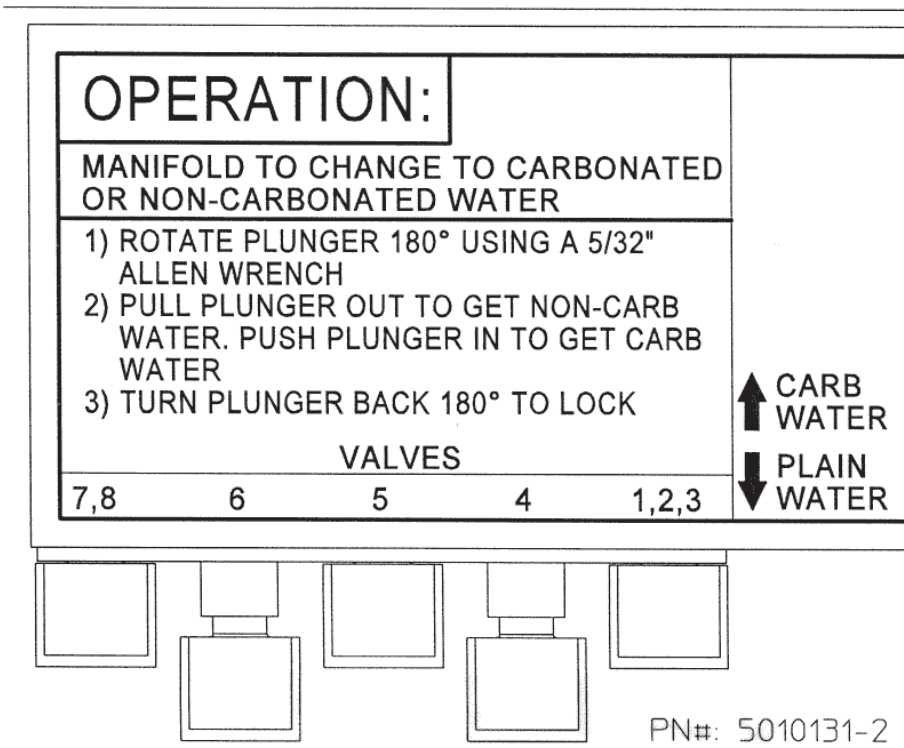

INSTALLATION

MD-200/250 8 VALVE PLUMBING DIAGRAM

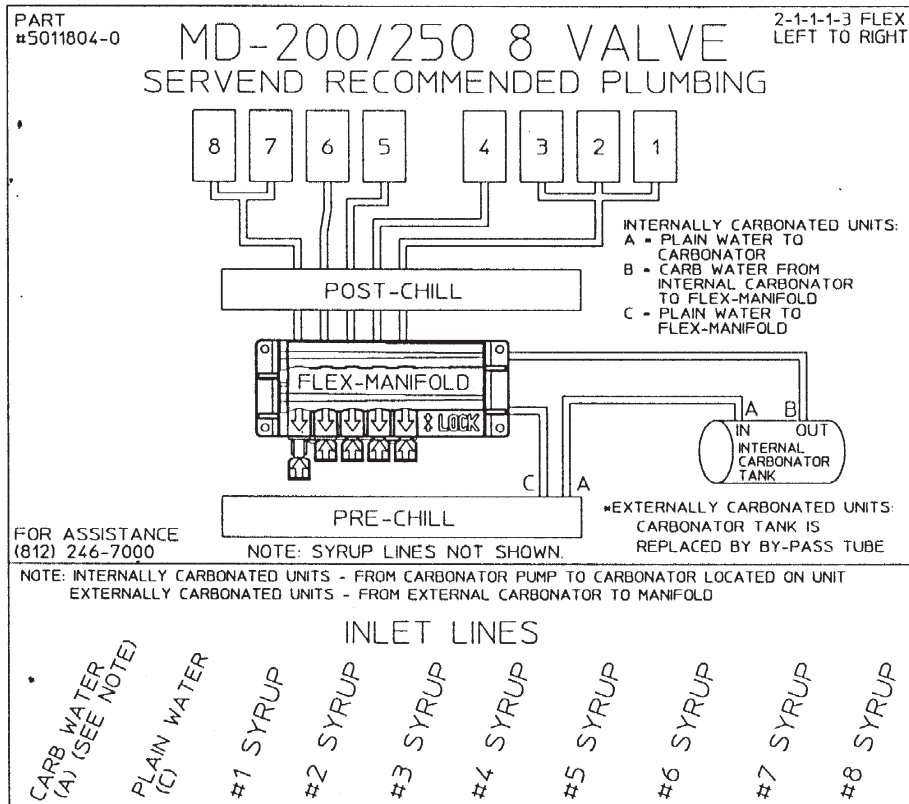

MD-200/250 8 VALVE FLEX MANIFOLD

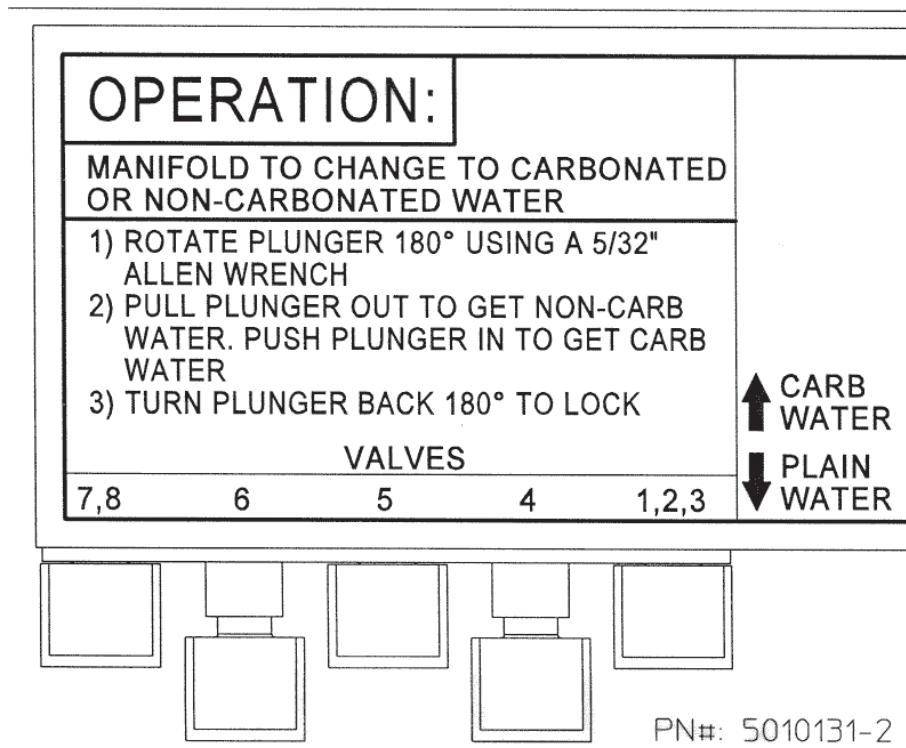

INSTALLATION

MD-200/250 10 VALVE PLUMBING DIAGRAM

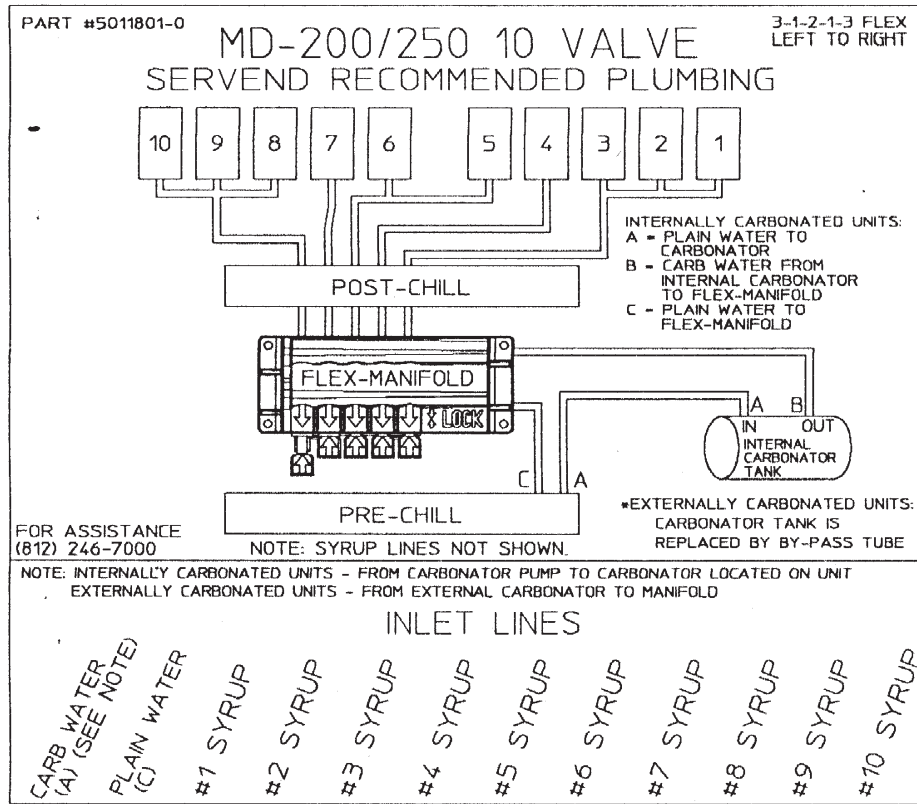

MD-200/250 10 VALVE FLEX MANIFOLD

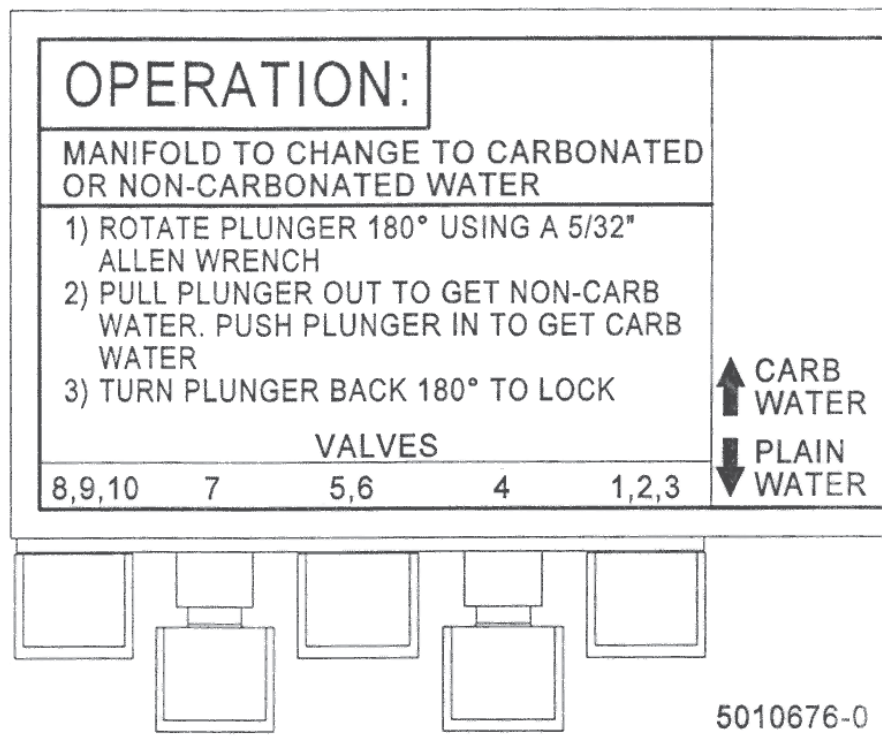

INSTALLATION

MD-302 12 VALVE PLUMBING DIAGRAM

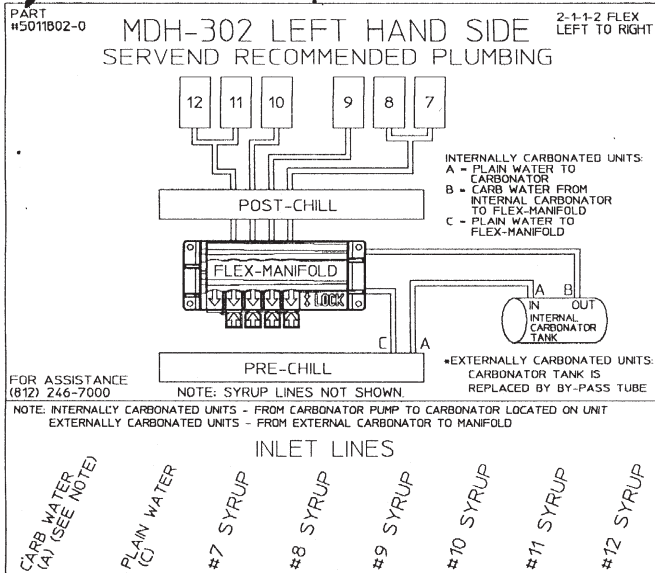

LEFT

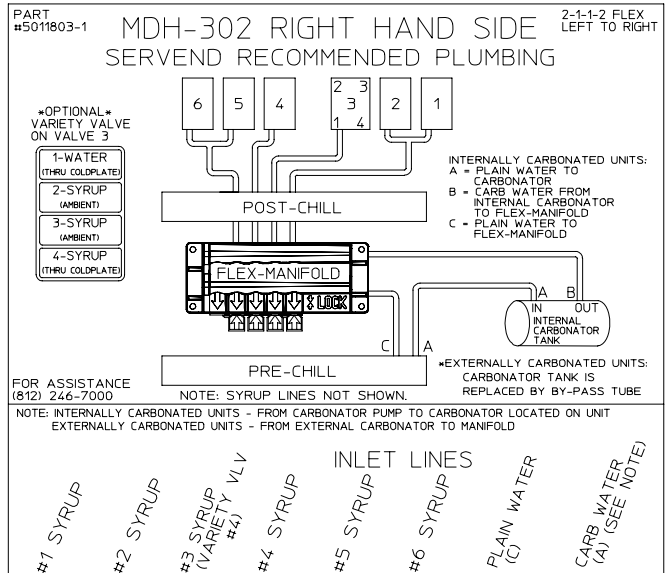

RIGHT

MD-302 12 VALVE FLEX MANIFOLD

(1 PER SIDE)

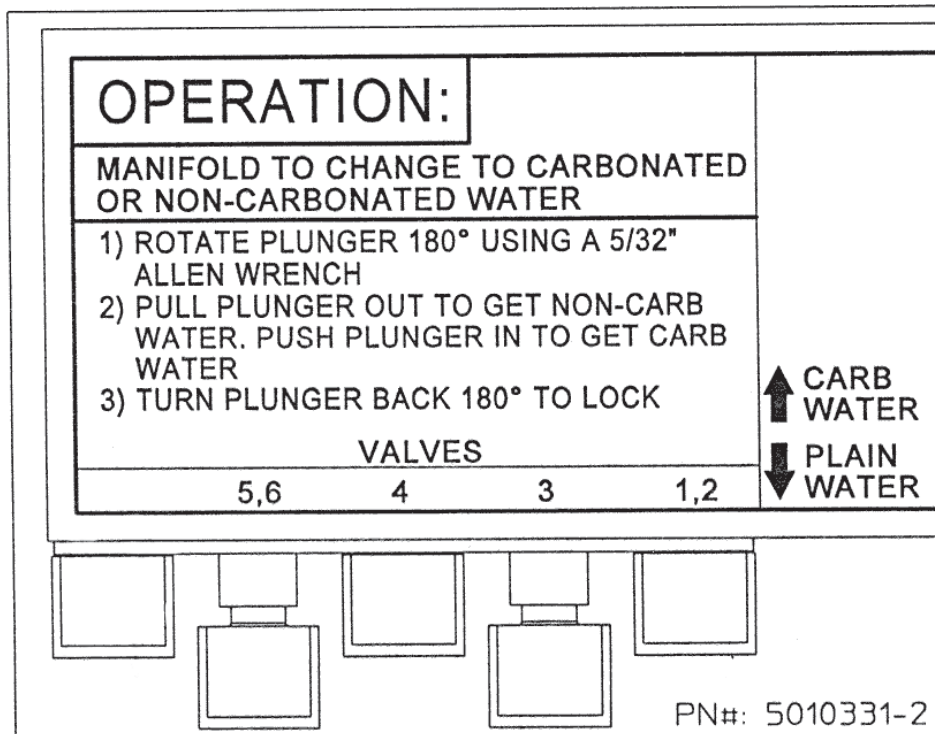

INSTALLATION

MD-402 16 VALVE PLUMBING DIAGRAMS

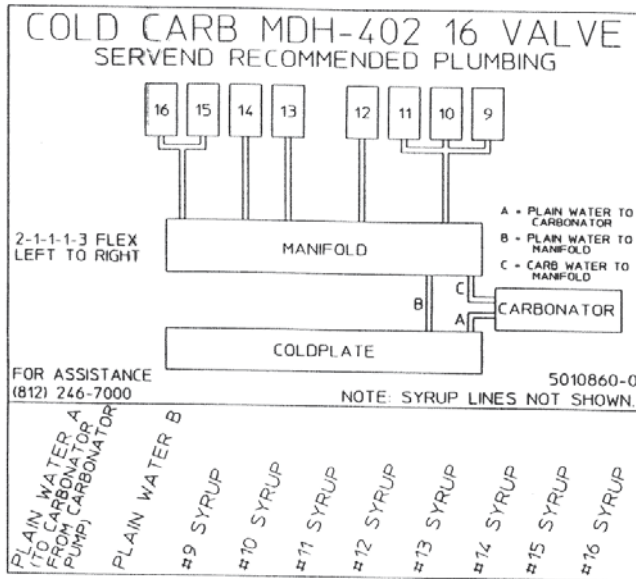

LEFT

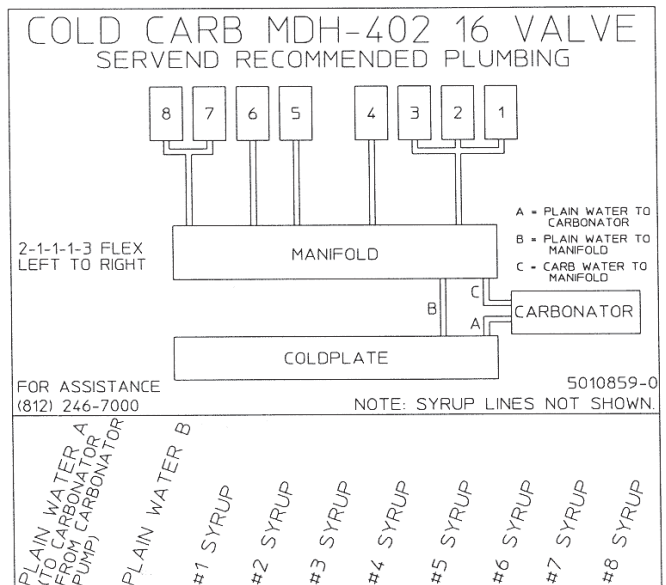

RIGHT

MD-402 16 VALVE FLEX MANIFOLD

(1 PER SIDE)

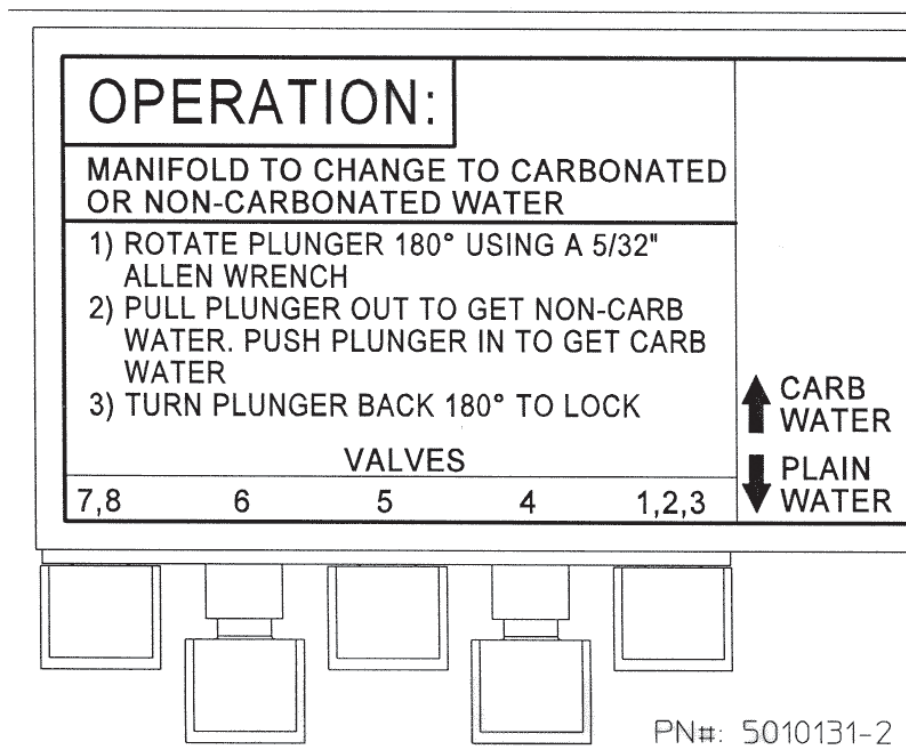

INSTALLATION

MD-402 20 VALVE PLUMBING DIAGRAMS

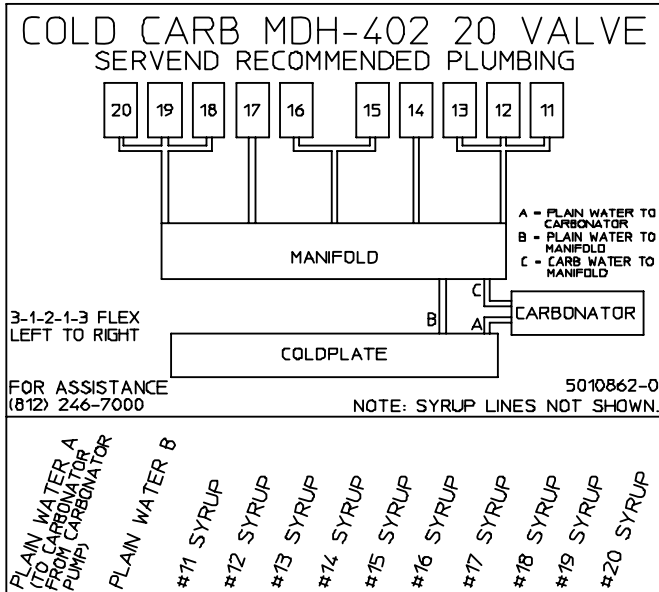

LEFT

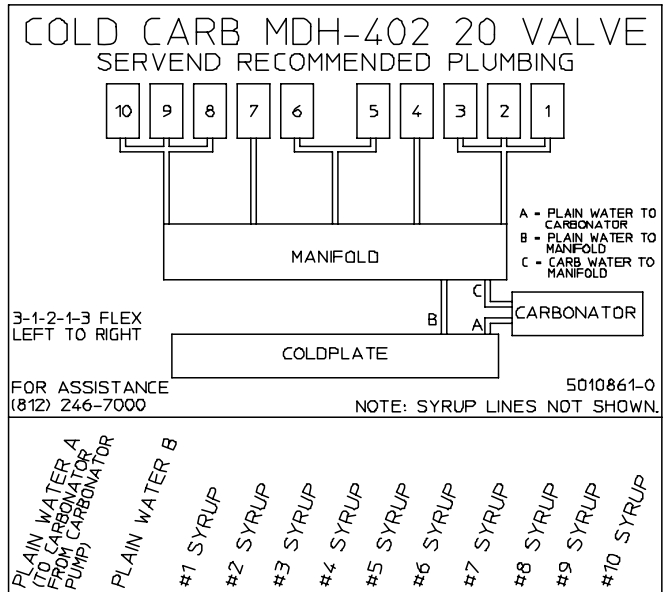

RIGHT

MD-402 20 VALVE FLEX MANIFOLD

(1 PER SIDE)

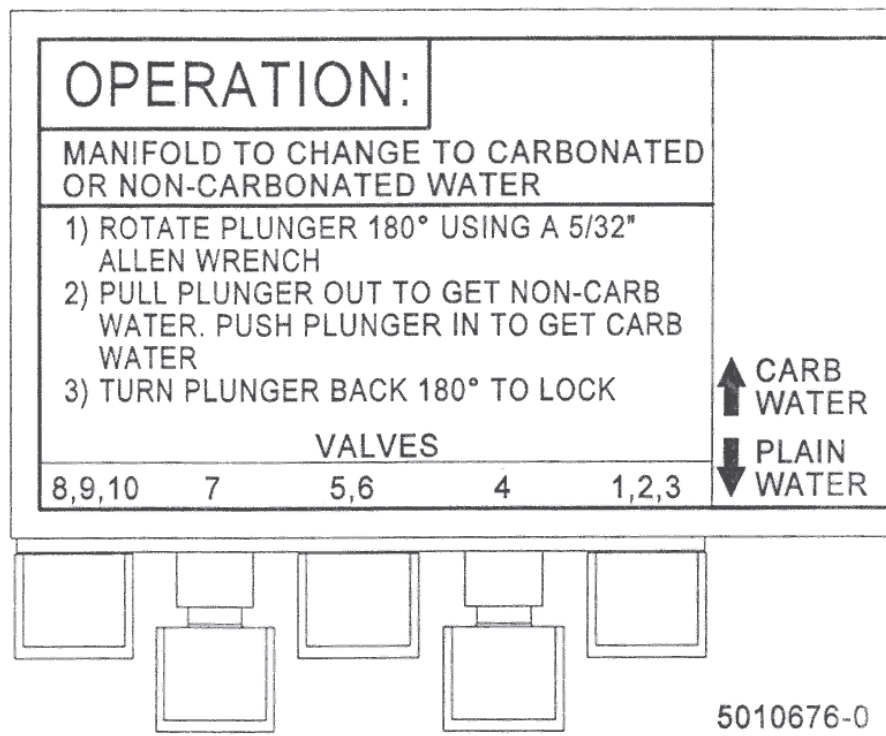

OPERATION

UNIT INSPECTION

Thoroughly inspect the unit upon delivery. Immediately report any damage that occurred during transportation to the delivery carrier. Request a written inspection report from a claims inspector to document any necessary claim.

ICE STORAGE AND DISPENSING



Servend dispensers are designed to dispense hard, cube ice up to one-inch square. The ice shapes and sizes listed below are recommended for dispensing. **Warm “Super Cooled” Ice Before Dispensing** “Super Cooled” ice is not recommended for dispensing. “Super cooled” ice is ice that has been stored in freezers below 32°F. Should it be necessary to temporarily use “super cooled” ice, allow the ice to warm at room temperature for 25 to 30 minutes before placing the ice in the dispenser.

Dispensing compressed flake “nugget” ice in Servend dispensers takes special handling. Most dispensers require special bin components plus a universal ice management kit. Contact MBE regarding details for your particular installation.

ROCKING CHUTE ICE DISPENSING

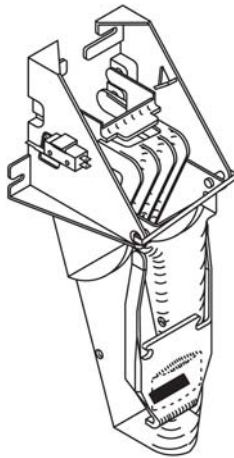

As the customer presses the rocking chute, the arm at the top left rear of the chute pushes upward on the door lock. The door opens until it contacts the stops in the mounting brackets. The plastic arm on the ice chute also activates the lever of the ice dispensing switch. When activated, the micro switch starts the gear motor. The gear motor turns the paddle wheel and agitator arm. The paddle wheel carries ice. Periodic agitation is optional on the MD-150 and MD-175 and is standard on the MD-200, MD-250, MD-302 and MD-402. During periodic agitation, the paddle wheel and agitator turn for approximately three seconds every three and one half-hours. The door lock prevents ice from being dispensed during the agitation cycle. (*See Also Sequence of Operation*)

COLD PLATE BEVERAGE COOLING

A cold plate is a block of aluminum with serpentine stainless steel tubes molded inside the aluminum block. The cold plate is approximately the same length and width as the bottom of the dispenser bin. Ice sits on top of the cold plate and cools the cold plate. The stainless steel tubes inside the cold plate carry carbonated water (soda water), noncarbonated water (plain water) and syrup to the beverage valves. While flowing through the stainless steel tubes in the cold plate, water and syrup are chilled to serving temperature.

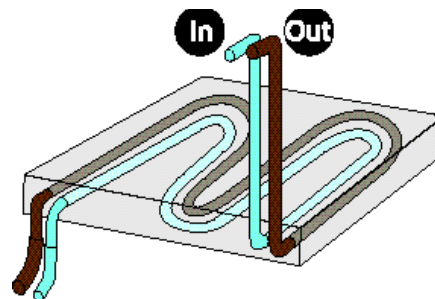

BEVERAGE VALVES

Post-mix beverage valves are designed to precisely meter the flow of both water and syrup to obtain the proper mixing ratio. The syrup and soda water components of the post-mix beverage are mixed as they leave the beverage valve.

OPERATION

AUTO BAG SELECTORS

These are used on higher volume B-I-B systems where two or more bags of the same product are connected to one pump and one system. An auto bag selector is essentially a valve that automatically changes from one bag (or series of bags) to another bag (or series of bags) of syrup as the bags empty, allowing a constant flow of product.

B-I-B

The Bag-In-Box system refers to a plastic disposable bag. The B-I-B normally contains 5 gallons of syrup, however some locations offer 2 1/2 or 3 gallon B-I-B units. This plastic bag is then held inside a cardboard or other container.

PUMPS

The syrup in a B-I-B system is delivered to the beverage system through gas operated pumps. These pumps extract the syrup out of the bags forcing the syrup throughout the system.

RACKING

Regardless if you are working on pre-mix or post-mix (B-I-B or Figal) system, a place will be designated for placement of the product. A rack (or shelf) system affords systematic placement and complete usage of the beverage paid for. The B-I-B rack allows the boxes to lay properly for syrup dispersal. Please check with your B-I-B syrup supplier. Some boxes must be slightly tilted down, while others may be in virtually any position. The Figal tank rack keeps the newer and full tanks organized at one end of the beverage line with the partial tanks at the other.

PRE-MIX & POST-MIX BEVERAGE DISPENSERS

Pre-Mix - Only a small number of systems use Pre-Mix, usually for temporary or very low volume dispensing where installation of a carbonator is not warranted.

Pre-Mix means that syrup and carbonated water are already mixed at the bottling plant, then chilled at the dispenser location before being served.

A memory peg for the meaning of Pre-Mix is that the syrup and carbonated water are mixed together before leaving the beverage valve.

Post-Mix - Most beverage systems are Post-Mix. Permanent dispensing locations with a mid to high volume dispensing have Post-Mix systems, such as self-service dispensers in Convenience Stores, Restaurants and Cafeterias.

Post-Mix means that syrup and carbonated water (or plain tap water for non-carbonated drinks) are mixed together in the valve nozzle of the dispenser, just before the finished beverage flows into the customer's cup.

A memory peg for the meaning of Post-Mix is that the syrup and water are mixed after leaving the beverage valve.

The two common Post-Mix systems are:

1. **Bag-in-Box (BIB)** - Most often, five gallons of syrup is stored in a plastic bag inside a carton.
2. **Figal** - Most often, five gallons of syrup is stored in a stainless steel canister.

Plumbing Diagram Label

The plumbing diagram label explains which inlet cold plate fittings supply which dispenser valves.

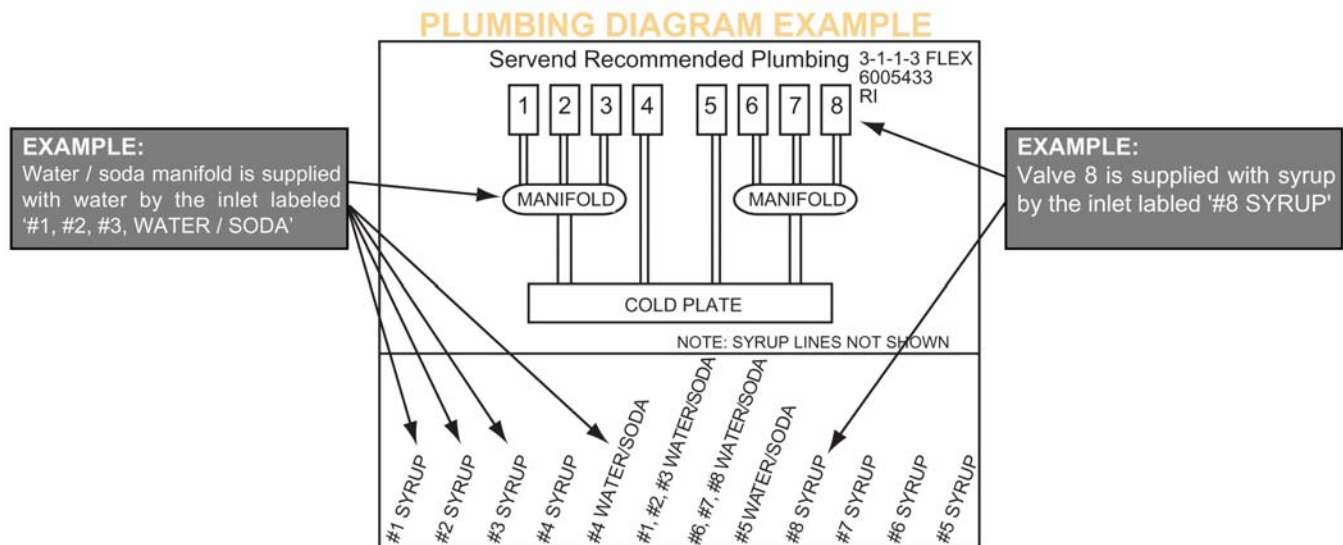

OPERATION

BACK ROOM PACKAGE

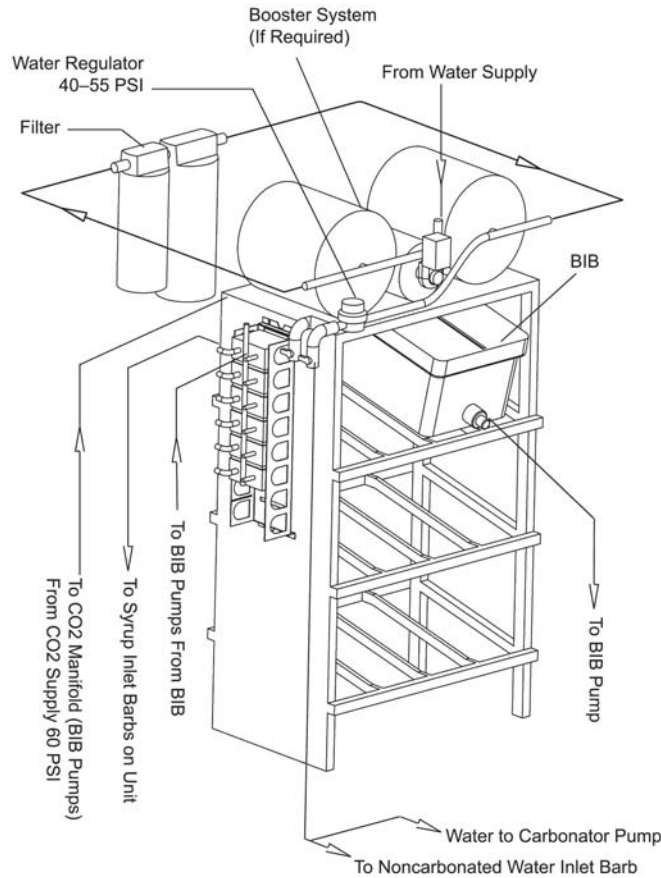

BAG-IN-BOX SYSTEM

Creating Carbonated Water:

- 1. Incoming tap water** - should be at a minimum dynamic pressure of 40 psi and maximum static pressure of 55 psi.
- 2. Carbonator Water pump motor** - Powers the water pump. The water pump motor is part of the carbonator pump deck.
- 3. Carbonator Water pump** - Pumps tap water into the carbonator tank. The water pump is part of the carbonator. The incoming water for the carbonator must be first ran through the pump before connecting to the proper cold plate inlet.
- 4. Internal/External Carbonator tank** - Combines CO₂ gas and tap water to form carbonated water. The "carbonator" is the carbonator tank, water pump and water pump motor.

On an ambient system, after being carbonated, the carbonated water is fed from the carbonator to the dispenser cold plate for chilling. At the beverage valve, chilled water and chilled syrup are mixed to create the finished beverage. A cold carbonated system pre-chills the water before entering the carbonator tank.

Pumping Syrup to the Dispenser:

- 5. CO₂ cylinder** - Holds highly pressurized carbon dioxide (CO₂). The CO₂ cylinder is a steel or aluminum cylinder tank. CO₂ gas flows to the primary pressure regulator.
- 6. Cylinder pressure gauge** - Indicates amount of CO₂ gas in the cylinder.
- 7. Primary pressure regulator** - Lowers the CO₂ gas pressure, to 100 psi, so the CO₂ gas will be at the proper pressure to enter the carbonator regulator.
- 8. Lowered outgoing pressure** - Set for 75 psi. Gauge indicated lowered outgoing pressure from the CO₂ cylinder after being routed through the primary pressure regulator at 100 psi..
- 9. Secondary pressure regulator** - Lowers the CO₂ gas pressure before the CO₂ gas flows to the syrup pump. CO₂ pressure, 60 to 75 PSI, activates the syrup pump.
- 10. Syrup pump** - Draws syrup out of the bag-in-box syrup package. Syrup flows through the syrup lines to the dispenser for chilling, then dispensing. There is a syrup pump for each bag-in-box syrup system.
- 11. Bag-In-Box syrup cartons** - Box which contains a plastic bag, filled with syrup.

OPERATION

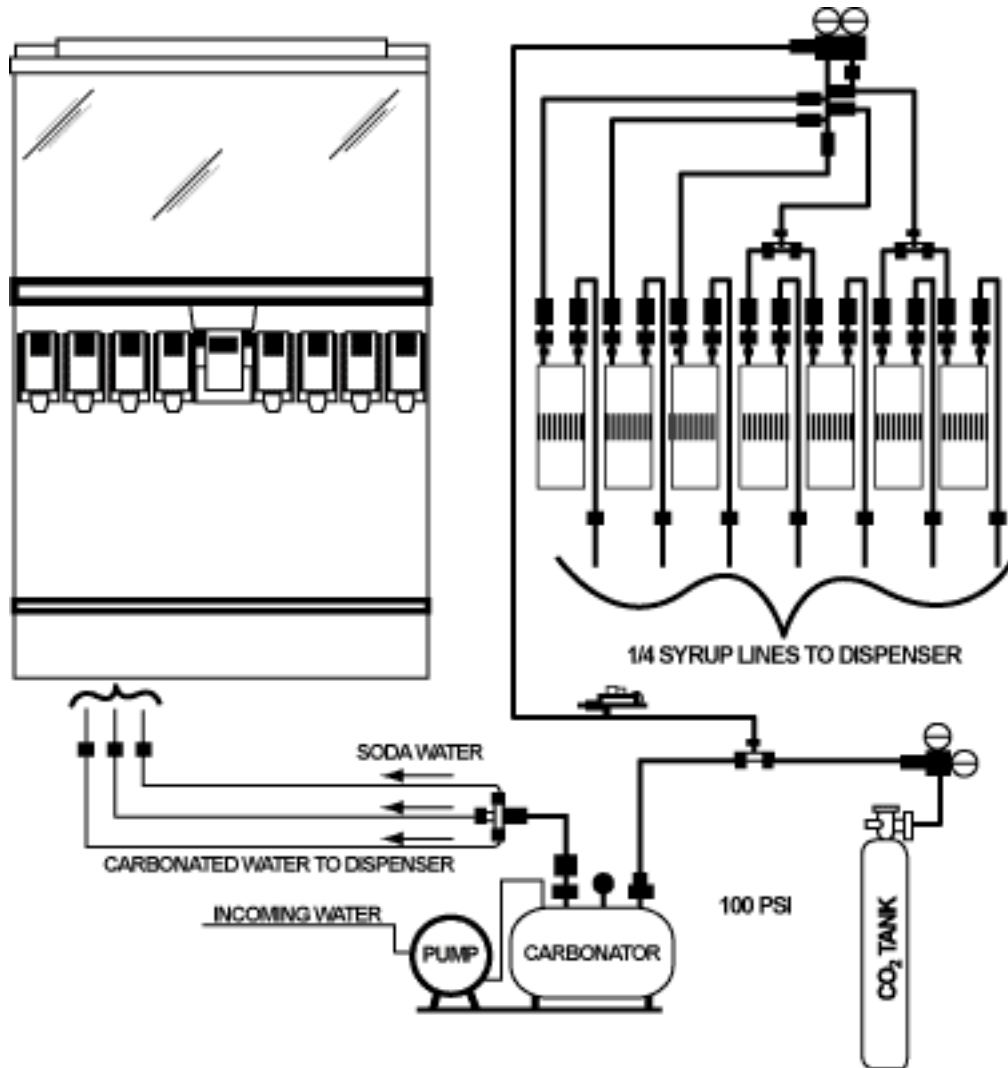

FIGAL SYSTEM

1. **CO₂ cylinder** - Holds highly pressurized carbon dioxide (CO₂). The CO₂ cylinder is a steel or aluminum cylinder tank. CO₂ gas flows to the primary pressure regulator.
2. **Primary pressure regulator** - Lowers the CO₂ gas pressure, usually to 100 psi.
3. **Lowered outgoing pressure gauge** - Gauge indicates lowered outgoing pressure from the CO₂ cylinder after being routed through the primary pressure regulator.

At a T-fitting, this line then forms two branches: One branch feeds CO₂ gas to the carbonator tank and the other branch feeds CO₂ gas to the Figal tanks.

Pumping Syrup to the Dispenser:

4. **Secondary pressure regulator** - Lowers the CO₂ gas pressure, usually at 45-60 psi, before the CO₂ gas flows to the Figal syrup tank. Diet syrup is usually 10-15 psi.
5. **Syrup pump** - Syrup flows through the syrup lines to the dispenser for chilling, then dispensing.
6. **Figal tanks** - Steel tank which usually holds five gallons of syrup. Several Figal tanks supply the dispenser.

OPERATION

CARBONATION

The purpose of the carbonator is to take water and combine it with CO₂ to create carbonated water. Tap water at street water pressure (minimum 40 PSI dynamic or flowing pressure in a 1/2" water line) must be forced into a tank that contains CO₂ (usually at 100 PSI) by using a pump to raise the water pressure above the CO₂ pressure. CO₂ is absorbed into the water as the water passes through the gas. Cooling and agitating the water will allow it to absorb more CO₂ gas. Chilling the mixture before dispensing will assist in locking the carbon dioxide into the water. After dispensing, the CO₂ may be unlocked from the liquid. The CO₂ will gradually leave the liquid due to pressure and temperature changes.

Components

The components of the carbonator are: water pump, an electric motor to operate the pump, carbonator tank where the water & CO₂ mix, and a water level control.

Operation

Carbon Dioxide (CO₂) leaves the storage tank and arrives at the carbonator tank through the gas inlet. Water supply enters the carbonator pump inlet at regular street water line pressure (minimum 40 PSI dynamic or flowing pressure). The water pump increases the pressure of the water, which allows the water to flow into the carbonator tank. The CO₂ and the water mix together in the carbonator to produce the carbonated water that is then sent to the soda dispenser.

The agitation of the water & CO₂ together in the tank under high pressure creates the soda water. The quality of carbonation (percent of CO₂ mixed in the water) increases as the water temperature decreases and exposure time increases.

The water level in the carbonator tank is controlled by a water level control in the tank. This control turns the pump motor off and on to maintain a preset level of liquid in the tank. The water level control may be electronic probes or a mechanical float.

INTERNAL CARBONATION

The carbonator tank has two inlets and one outlet connection, as well as a relief valve and two conductivity probes. The water inlet is a double check valve topped with a 3/8" flared fitting. The carbonator will be pre-plumbed as it leaves the factory. If the carbonator needs to be serviced or if the fittings need to be replaced, make sure a nylon washer is used inside the CO₂ inlet fitting to prevent leaks.

The conductivity probes are used to control the level of water inside the carbonator tank. The red probe, or the "high" probe, is the shorter of the two. When the level of the water reaches the bottom of the red probe, the pump shuts off. When the water level inside the tank goes below the bottom tip of the of the black or low probe. Both probes are wired to the electronic liquid

level control, which is a circuit board mounted inside the electrical box that activates the pump and motor. Removing the cover of the electrical box will grant access to the circuit board. As the control receives a signal from the conductivity probes, it activates the pump motor, which will pump water into the carbonator until the water reaches the high probe.

The pump motor and electrical box are mounted together on a single platform. The pump is a standard 125 GPH brass rotary vane pump. The flared fittings accept the same swivel/barb connectors used on the carbonator water connections. Also, water enters the pump from the water source on the side that has the filter.

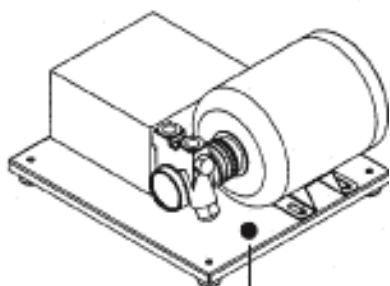

Carbonator Pump Deck
(Power Supply)

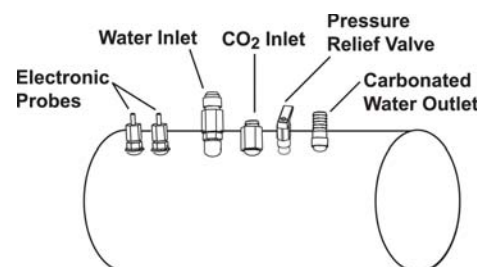

Notes:

- **Pump Decks for internal carb units must be within 6 feet of unit.**
- **Installation of a carbonator any further away than the recommended distance is at installer/owner's risk. Known issues can include, but is not limited to poor carbonation and/or erratic carbonation.**

OPERATION

MD SERIES COUNTERTOP MEASUREMENTS

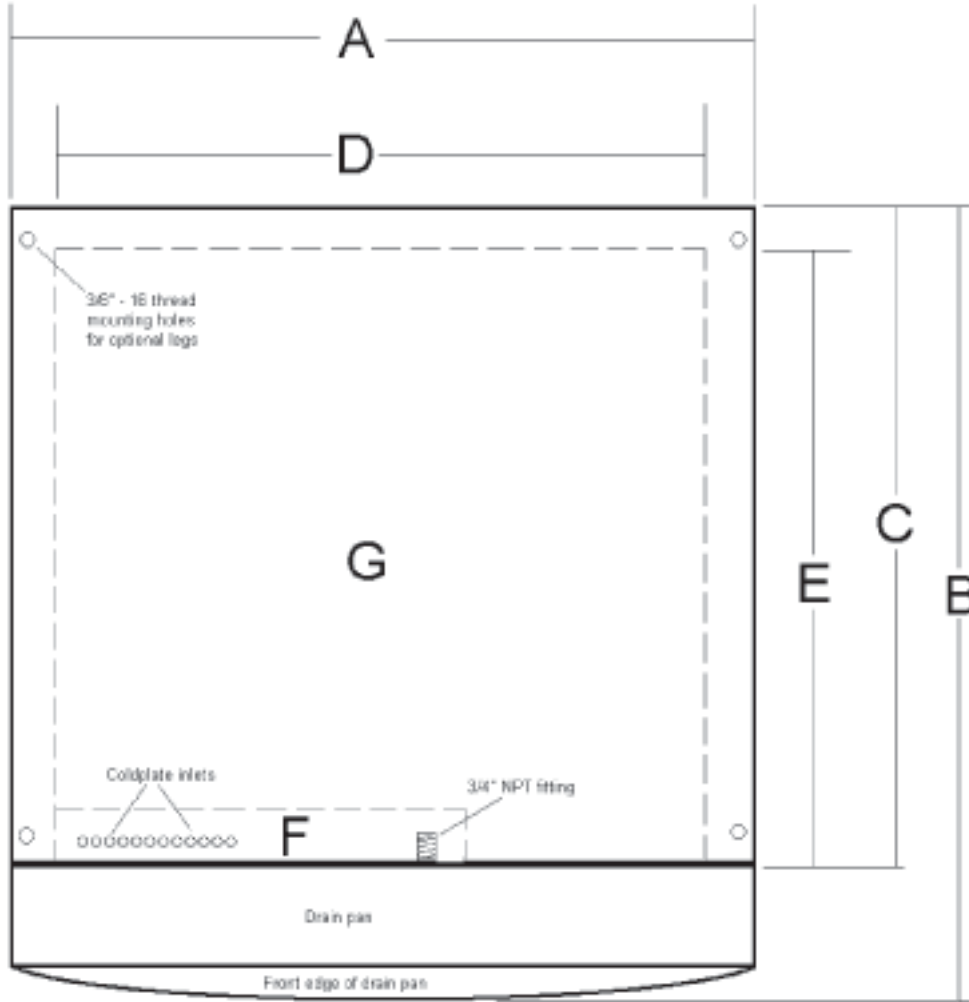

Letter	Description	MD-150	MD-175	MD-200/250	MD-250-36
A	Unit Width	22"	24"	30"	36"
B	Unit Depth	30 1/2"	30 1/2"	30 1/2"	30 1/2"
C	Outside Ice Bin Depth	22"	22 1/2"	22 1/2"	22 1/2"
D	Under Unit Width	18"	20"	26"	32"
E	Under Unit Depth	20 1/2"	20 1/2"	20 1/2"	20 1/2"
F	Recommended countertop Cut-out*	3"x13"	3"x14"	3"x18"	3"x18"
G	Maximum Countertop Cut-out*	18"x20 1/2"	20"x20 1/2"	26"x20 1/2"	32"x20 1/2"

CAUTION: *Cutting the countertop may decrease its strength. Counter should be braced to support the dispenser countertop weight plus ice storage capacity and weight of icemaker, if applicable.

OPERATION

MD SERIES SPECIFICATIONS

MD Series dispensers have a stainless steel cabinet and lighted merchandiser standard. Beverage valves, coldplate connections, drain connections and electrical components are front serviceable. MD Series dispensers drain through a single $\frac{3}{4}$ " NPT connection to the drain pan. The standard voltage for MD Series dispensers is 120VAC-60Hz. A power cord is provided with 120VAC-60Hz models only.

MD Series dispensers are available in the following optional voltages:

- 100VAC-50/60Hz
- 220VAC-50Hz
- 220VAC-60Hz

MD Series dispensers use a $\frac{1}{7}$ hp gearmotor. Optimum ambient conditions for MD Series dispensers are between 50°F and 95°F.



	MD-150	MD-175	MD-200	MD-250	MD-250-36
Dimensions WxDxH	22" x 30 1/2" x 33"	24" x 30 1/2" x 34"	30" x 30 1/2" x 33"	30" x 30 1/2" x 39"	36" x 30 1/2" x 39"
Ice Storage	150 lbs	175 lbs	200 lbs	250 lbs	250 lbs
Beverage Valves	6	8	8 or 10	8 or 10	10 or 12
Coldplate	9 circuit 3-2-1 manifold	12 circuit 3-1-1-3 manifold	8 valve: 12 circuit 3-1-1-3 manifold 10 valve: 15 Circuit 3-1-2-1-3 manifold	8 valve: 12 circuit 3-1-1-3 manifold 10 valve: 15 circuit 3-1-2-1-3 manifold	13 circuit Soft plumbed water circuits, 8 hard-plumbed syrup circuits
Amperage	2.5 FLA	2.8 FLA	2.5 FLA	2.5 FLA	2.5 FLA
Agitation Timer	Optional	Optional	Standard	Standard	Standard
Shipping Weight	240 lbs	259 lbs	318 lbs	338 lbs	338 lbs

OPERATION

MDH SERIES COUNTERTOP MEASUREMENTS

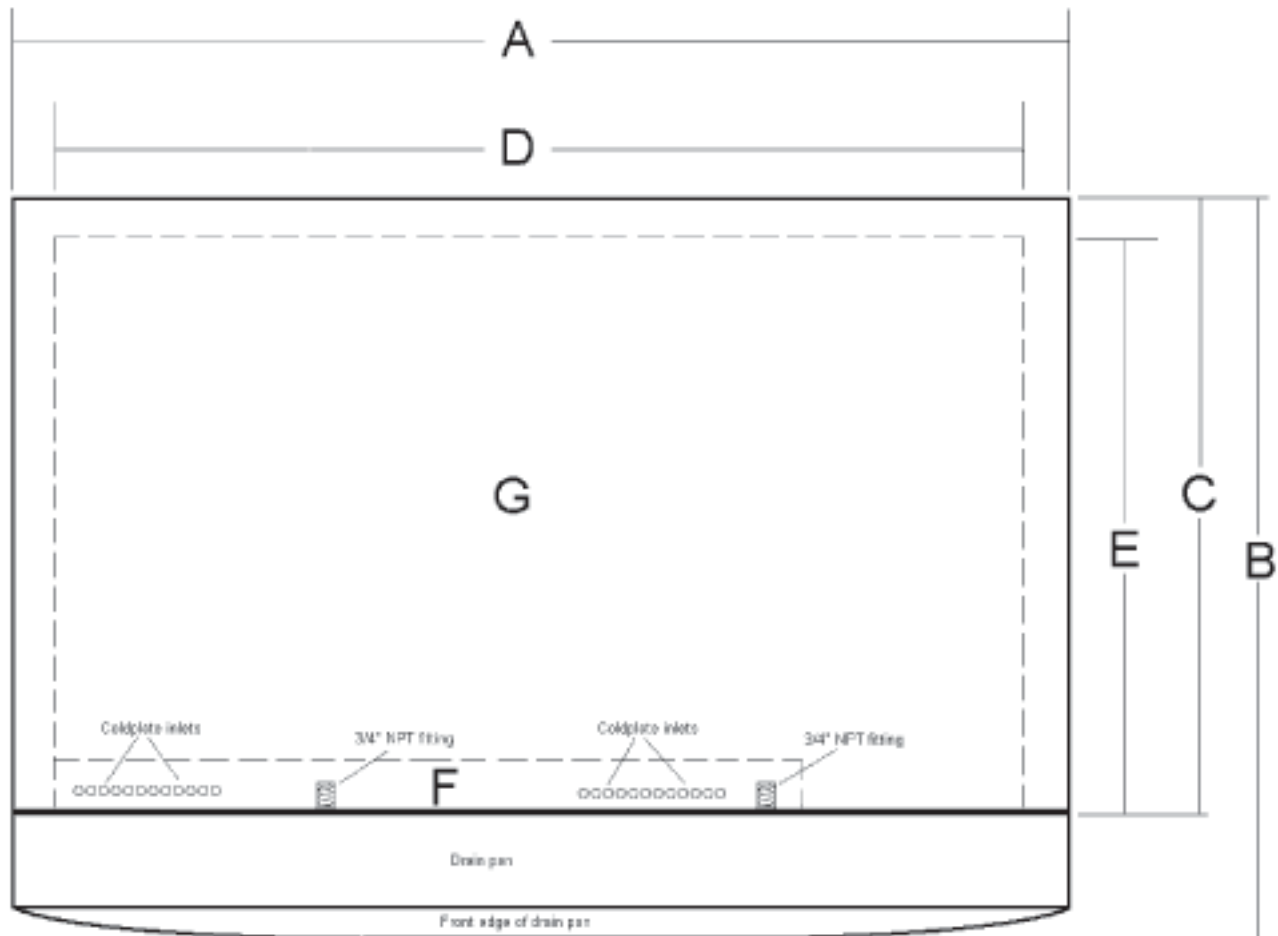

Letter	Description	MDH-302	MDH-402
A	Unit Width	42 ¾"	60"
B	Unit Depth	30 ½ "	30 ½"
C	Outside Ice Bin Depth	22 ½"	22 ½"
D	Under Unit Width	38 ¾"	56 ½"
E	Under Unit Depth	20 ½"	21 ¼"
F	Recommended Countertop Cut-out*	3" X 32"	3" X 48"
G	Maximum Countertop Cut-out*	38 ¾" X 20 ½"	56 ½" X 21 ¼"



CAUTION: *Cutting the countertop may decrease its strength. Counter should be braced to support the dispenser countertop weight plus ice storage capacity and weight of icemaker, if applicable.

OPERATION

MDH SERIES SPECIFICATIONS

MDH Series dispensers have a stainless steel cabinet and lighted merchandiser standard. Beverage valves, coldplate connections, drain connections and electrical components are front serviceable. MDH Series dispensers drain through a two $\frac{3}{4}$ " NPT connection to the drain pan. The standard voltage for MDH Series dispensers is 120VAC-60Hz. A power cord is provided with 120VAC-60Hz models only.

MDH Series dispensers are available in the following optional voltages:

- 100VAC-50/60Hz
- 220VAC-50Hz
- 220VAC-60Hz

MDH Series dispensers use two $\frac{1}{7}$ hp gearmotor. Optimum ambient conditions for MDH Series dispensers are between 50°F and 95°F.



	MDH-302	MDH-302 w/EM	MDH-402	MDH-402 w/24" EM	MDH-402 w/34" EM
Dimensions W x D x H	42 ¾" x 30 1/2" x 33"	42 ¾" x 30 1/2" x 44"	60" x 30 1/2" x 32"	60" x 30 1/2" x 44"	60" x 30 1/2" x 54"
Ice Storage	300 lbs	300 lbs	400 lbs	400 lbs	400 lbs
Beverage Valves	10 or 12	10 or 12	16 or 20	16 or 20	16 or 20
Coldplate	Two (2) 9 circuit 3-2-1 manifold	Two (2) 9 circuit 3-2-1 manifold	16 valve: Two (2) 12 circuit 3-1-1-3 manifold 20 valve: Two (2) 15 circuit 3-1-2-1-3 manifold	16 valve: Two (2) 12 circuit 3-1-1-3 manifold 20 valve: Two (2) 15 circuit 3-1-2-1-3 manifold	16 valve: Two (2) 12 circuit 3-1-1-3 manifold 20 valve: Two (2) 15 circuit 3-1-2-1-3 manifold
Amperage	3.5 FLA	4.0 FLA	4.5 FLA	4.5 FLA	5.0 FLA
Agitation Timer	Standard	Standard	Standard	Standard	Standard
Shipping Weight	430 lbs	490 lbs	615 lbs	715 lbs	715 lbs

OPERATION

ROCKING CHUTE ICE DELIVERY SWITCH ADJUSTMENT

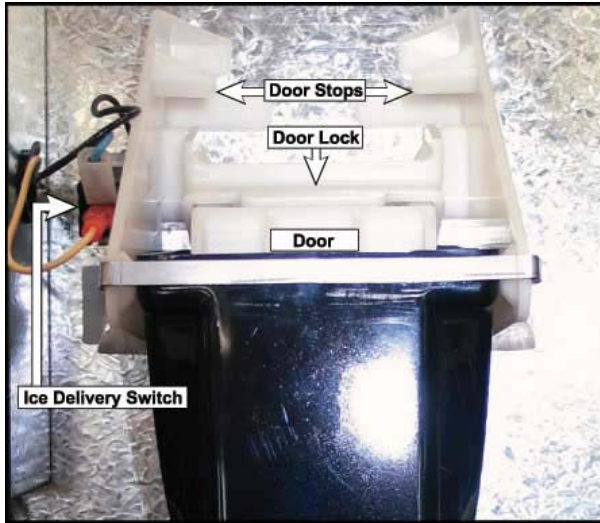

① To properly adjust the switch, first unplug the power cord to the unit then remove the merchandiser. This will give you access to the ice delivery switch located on the left side of the rocking chute.

② Begin by observing the chute by slowly pushing against the rocking chute. When the ice delivery switch clicks, measure the distance from the door stops on the rocking chute bracket to the door. The distance between the two should be no more than 1/4", but no less than 1/16".

③ The left side of the rocking chute has a tab that pushes up on the ice delivery switch. To adjust it, use needle nose pliers and bend the arm of the switch up or down in order to change the point where the tab makes contact with the switch arm.

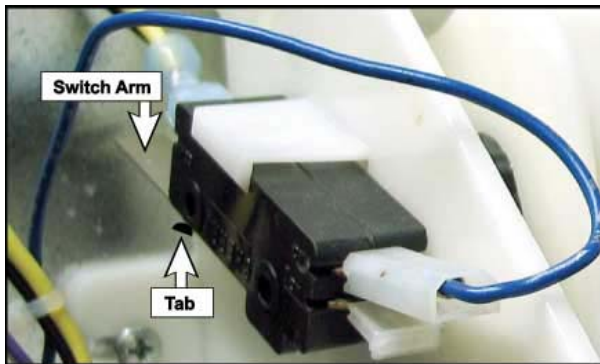
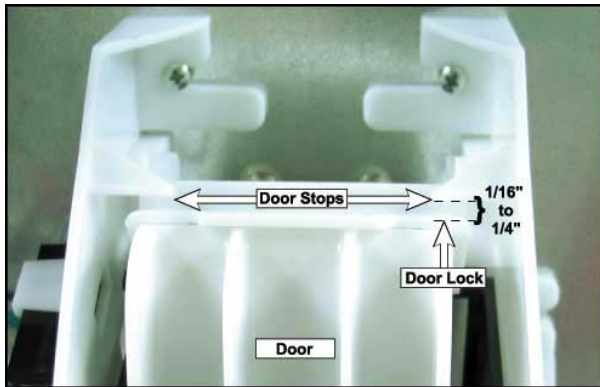

OPERATION

SETTING THE AUTOMATIC AGITATION TIMER

Some MD Series ice / beverage dispensers have an optional timer, which agitates ice stored in the dispenser bin. The timer is preset at the factory for three seconds ice agitation every three and one half hours. Beginning July, 1999 this timer is not adjustable. To reset the older style timer, use the following procedure:

1. Place a small **screwdriver** in the adjustment pot marked "ON" (See illustration at right).
2. Gently turn the adjustment pot counterclockwise until the adjustment pot will no longer turn. One of the cross hairs on the dial will be approximately in the "7 o'clock" position.
3. Turn the adjustment pot clockwise, approximately to the "10 o'clock" position. This is two notches past the zero setting and sets the timer for approximately three seconds of ice agitation.
4. Place a small **screwdriver** in the adjustment pot marked "OFF" (See illustration at right).
5. Gently turn the adjustment pot counterclockwise until the adjustment pot will no longer turn. One of the cross hairs on the dial will be approximately in the "7 o'clock" position. This sets the adjustment pot at zero hours of timing between agitation periods.
6. Turn the adjustment pot to the right, approximately to the "2 o'clock" position. This is approximately nine notches past the zero setting and sets the timer for agitation approximately every three and one half hours.

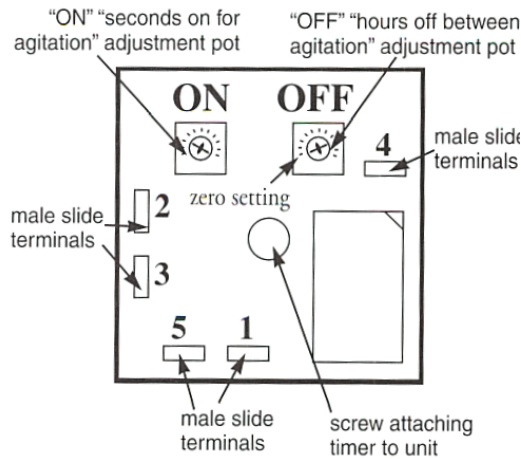

To test the adjustable timer, turn the "ON" time to the correct three second position. Turn the "OFF" time to the zero "7 o'clock" position. Do not disturb the dispenser for 15 minutes. The timer will operate if good.

Dispensers made since July 1999 (99G) have non adjustable timers. To test these timers, unplug the dispenser, wait five seconds, then plug the dispenser in. If the timer is good, it will agitate immediately upon the dispenser being plugged in.

115V/220V NON ADJUSTABLE AGITATION TIMER

The agitation timer on this unit is equipped with test pins. This allows you to test the timer by removing the jumper between the two pins. When the jumper is removed the timer will cycle every 55 seconds if it is operating correctly. If the timer is wired correctly and does not cycle approximately every 55 seconds when the jumper is removed, replacement of the timer may be necessary. Make sure to replace the jumper pins when finished.

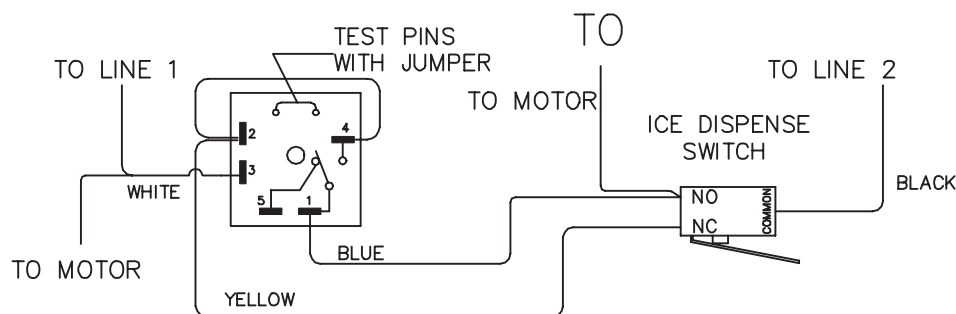

NOTES: This timer is re-settable, timed agitation every 3.5 hours from last dispense on power supply broken. Never operate in normal mode without test pins in place, damage could occur.

OPERATION

SEQUENCE OF OPERATION

Manufactured beginning early 1994

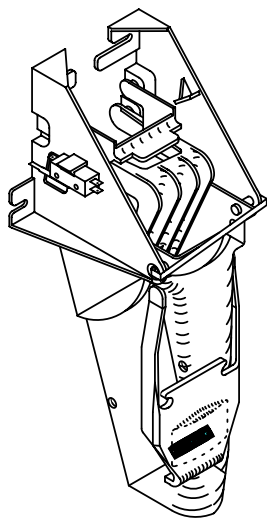

Customer's cup presses rocking chute push lever or customer's hand presses push button. The clear plastic arm at the top and the left rear of the clear plastic chute pushes upward on the door.

The door pivots up from the left and right mounting brackets.

The clear plastic arm at the top and left rear of the ice chute also activates the lever of the micro switch. When activated, the micro switch starts the gear motor. The gear motor turns the paddle wheel and agitator arm.

When the paddle wheel turns, ice is carried from the bottom of the bin to the dispense point. Ice falls forward through the open door, into the ice chute and to the customer's cup.

The door lock keeps the door shut during periodic agitation. Periodic agitation is optional on the MD-150 and MD-175. Periodic agitation is standard on the MD-200, MD-250, MD 250-36, and MDH-302.

During periodic agitation, the paddle wheel and agitator turn for approximately three seconds every three and one half-hours of non-use. Since ice is brought forward during periodic agitation, ice would fall through the ice dispense door if the door lock was not present.

Manufactured before early 1994

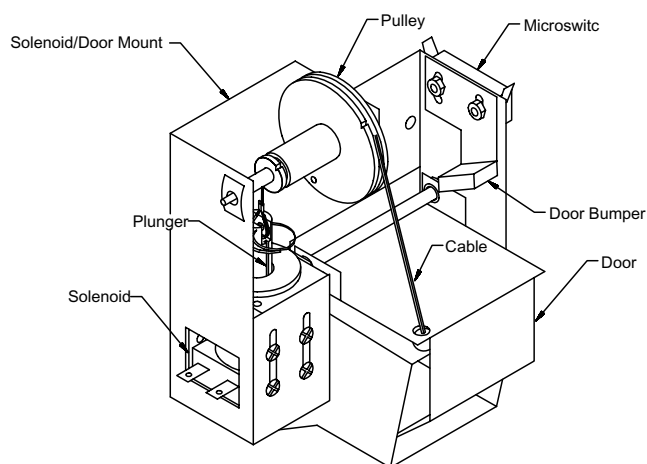

Customer's cup presses against the push plate. The push plate raises the microswitch actuator arm located on the right side of the ice dispense chute. The microswitch actuator arm activates the microswitch.

The microswitch activates the solenoid, which pulls down the solenoid plunger. The plunger is connected to a cable, which is connected to a pulley, then another cable raises the door of the ice chute.

The microswitch also activates the gear motor. The gear motor turns the agitator and paddle wheel, lifting ice from the bottom of the bin to the ice dispense point. Ice falls forward through the open door, through the bin spout, into the ice chute and to the customer's cup.

Push Button Ice Dispensing, Solenoid, Cable Style Door

Customer's finger presses the push button, located in the merchandiser frame. The button is labeled, "PUSH FOR ICE".

The push button energizes the plunger micro-switch. The microswitch activates the solenoid, which pulls down the solenoid plunger. The plunger is connected to a cable, which is connected to a pulley, then another cable raises the door of the ice chute.

The microswitch also activates the gear motor. The gear motor turns the agitator and paddle wheel, lifting ice from the bottom of the bin to the ice dispense point. Ice falls forward through the open door, through the bin spout, into the ice chute and to the customer's cup.

USER MAINTENANCE

PREVENTATIVE MAINTENANCE

Preventative maintenance is a vital part of keeping your Servend dispenser in top condition. Following the guidelines below will assist you in continued trouble free operation of your unit. Contact MBE at 1-800-367-4233 for more information about our **ProActive Maintenance Program**.

1. Conduct daily maintenance of the machine.
2. Perform monthly maintenance of the machine.
3. Perform periodic maintenance and sanitizing of beverage system.
4. Do not overfill the dispenser bin with ice.
5. Do not allow the dispenser to sit for prolonged periods of non use with ice in the bin.
6. Most ice dispenser service problems are caused by low usage of the ice dispenser.
7. Do not allow ice to remain in the bin more than a day in order to prevent ice from freezing together and/or stagnant ice.

Possible excess ice storage reasons:

- Storage capacity exceeds daily requirements.
- Low demand during the off season.
- Dispenser oversized with future growth in mind.

Lower ice storage to meet one day's needs. If you manually fill ice, fill only with the appropriate amount of ice. Fill the dispenser with fresh ice each morning. Do not fill the dispenser at night just before shut down. Ice cubes can freeze together if not dispensed.

HOW TO DISASSEMBLE FOR CLEANING OR MAINTENANCE

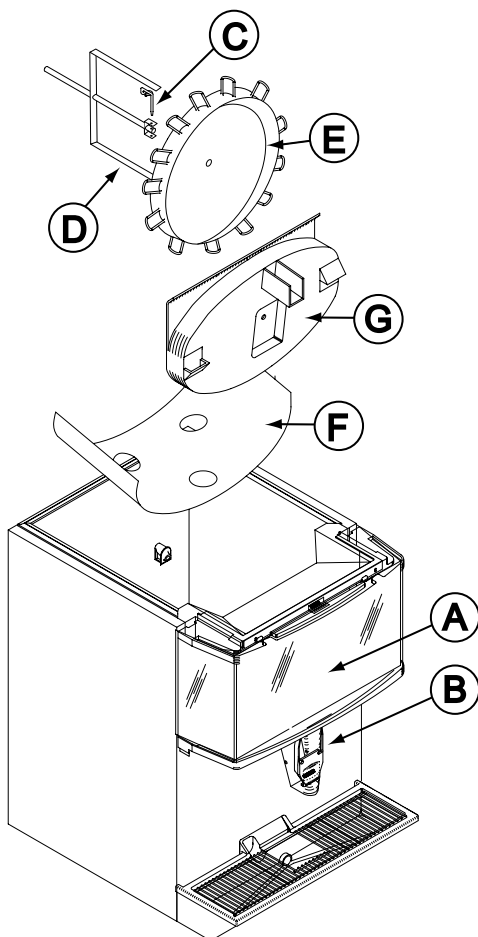
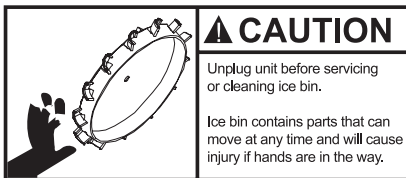

NOTE: Sanitize the ice dispenser at Initial Start-UP in addition to monthly sanitizing. You will need [screwdriver](#) in order to disassemble.

Disassemble parts in the following order:

- | | |
|---------------------|----------------------|
| A. Merchandiser | E. Paddle wheel |
| B. Ice chute | F. Bin liner |
| C. Paddle wheel pin | G. Paddle wheel Area |
| D. Agitator | |

Accessing a Dispenser Bin Top Mounted with a Manitowoc Cuber:

1. Remove the front panel of the ice machine.
2. Remove the ice deflection baffle. This will give you access to the dispenser bin.

Accessing a Dispenser Bin that is Top Mounted with a Manitowoc Cuber and Large Extended Merchandiser in front of the Cuber:

1. Access to the bin is possible through the strip lids on the side of the Dispenser.

Disassembling the Dispenser Parts for Bin Cleaning:

1. Remove the front panel of the Manitowoc ice maker.
2. If the Manitowoc ice maker is operating, wait for the sheet of ice to fall into the dispenser bin.

When the ice sheet falls into the dispenser bin, immediately place toggle switch of the ice machine to the "OFF" position.

If the Manitowoc ice maker is NOT operating, place the toggle switch of the ice machine to the "OFF" position.

3. On MD models without a top mounted cuber, remove the plastic lit from the top of the dispenser.
4. Remove all ice from the dispenser.
5. Disconnect electrical power to the dispenser.
6. On the MD-302 dispenser only, remove the strip lids off the top left and top right of the dispenser bin.
7. For the MD-302 dispenser only, there is a left bin and a right bin. Clean and sanitize one bin, then follow the same procedures on the second bin.

USER MAINTENANCE

HOW TO DISASSEMBLE FOR CLEANING OR MAINTENANCE

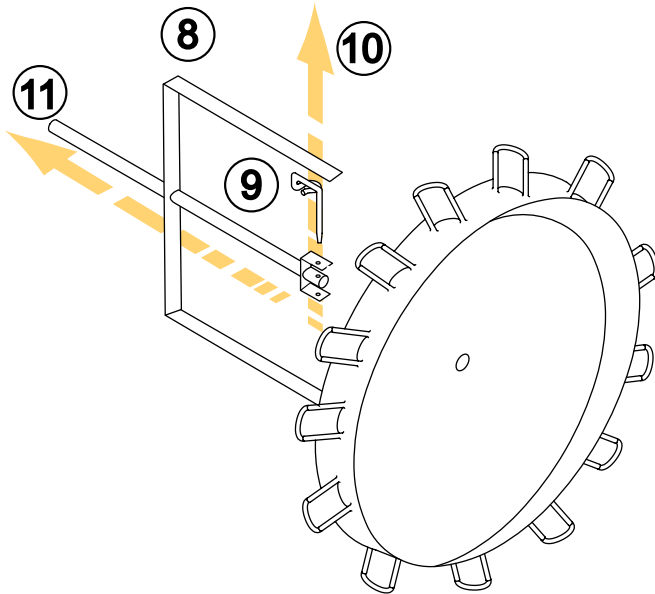

Agitator arm and paddle wheel pin:

8. Rotate the agitator arm so the paddle wheel pin handle is pointing up, toward the ceiling. For the MD-302 dispenser only, reach inside the bin through the area where the strip lid has been removed.
9. Loosen the hand-removable paddle wheel pin from the agitator by twisting counter clockwise until it snaps from the agitator bar...
10. Then remove the paddle wheel pin from the hole in the agitator.
11. Push the agitator bar toward the back of the unit until the agitator is free of the paddle wheel hub.
12. Move the front of the agitator to one side and slide the agitator forward until the rear of the agitator shaft is clear of the bushing.
13. Remove the agitator from the bin area.

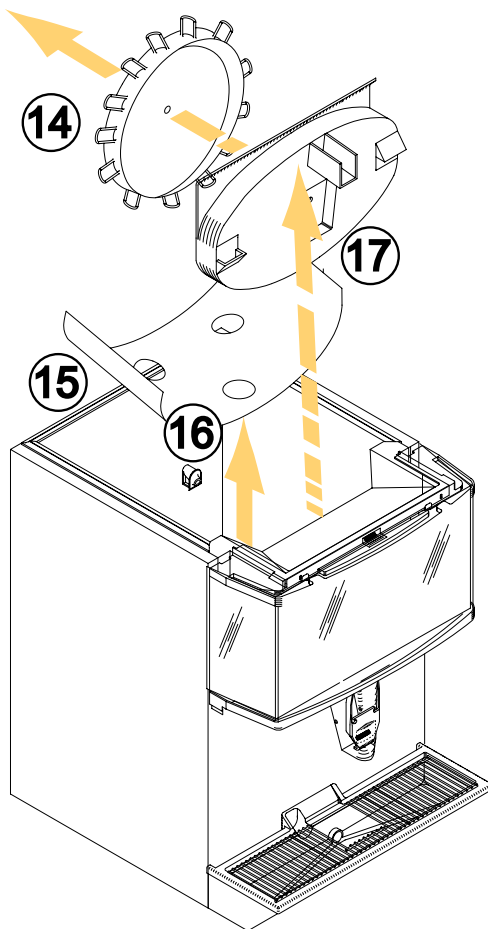

Paddle wheel, bin liner and paddle wheel area:

14. Slide the paddle wheel from its shaft.
15. Loosen the four knurled fasteners that hold the bin liner in place.
16. Remove the bin liner.
17. Remove the paddle wheel area from the bin.
For the MD-302 dispenser only, remove the paddle wheel area to the back of the bin.
18. Discard the remaining ice in the bin.

USER MAINTENANCE

HOW TO DISASSEMBLE FOR CLEANING OR MAINTENANCE

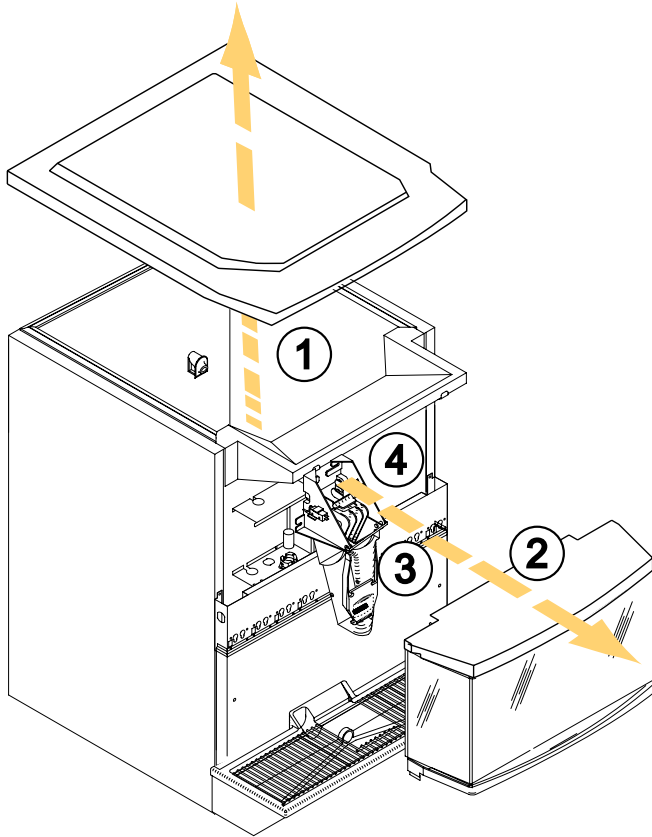

Disassemble the rocking chute:

1. Loosen the two knurled fasteners that hold the merchandiser in place.
2. Remove the merchandiser.
3. Remove outer bracket.
4. Remove door lock.
5. Remove door.
6. Remove ice chute.
7. Model MD-302 has two rocking chutes. Remove both rocking chutes using the same procedure above.

Disassemble the solenoid style chute:

1. Loosen the knurled fastener on both sides of the outer chute and remove chute from the dispenser.

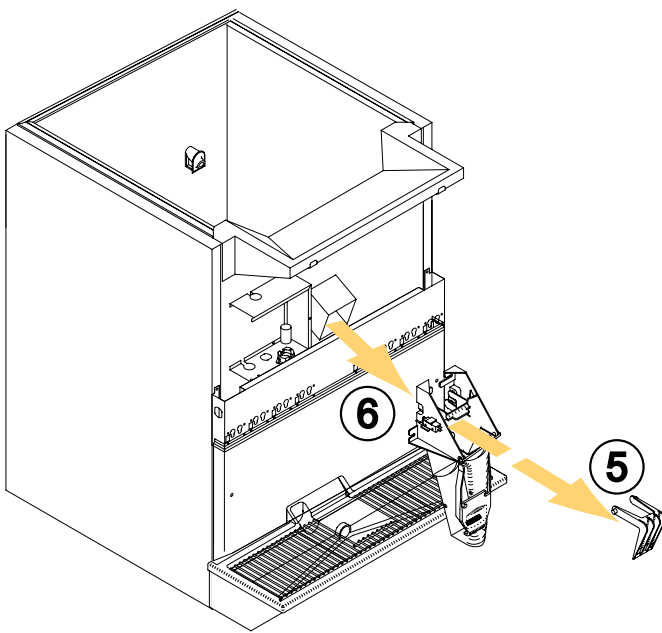

USER MAINTENANCE

DAILY CLEANING

All cleaning must meet your local health department regulations. The following cleaning instructions are provided as a guide.



CAUTION: Use only warm soapy water to clean the exterior of the tower. Do not use solvents or other cleaning agents. Do not pour hot coffee into the drain pan. Pouring hot coffee down the drain pan can eventually crack the drain pan, especially if the drain pan is cold or still contains ice.

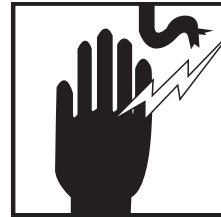
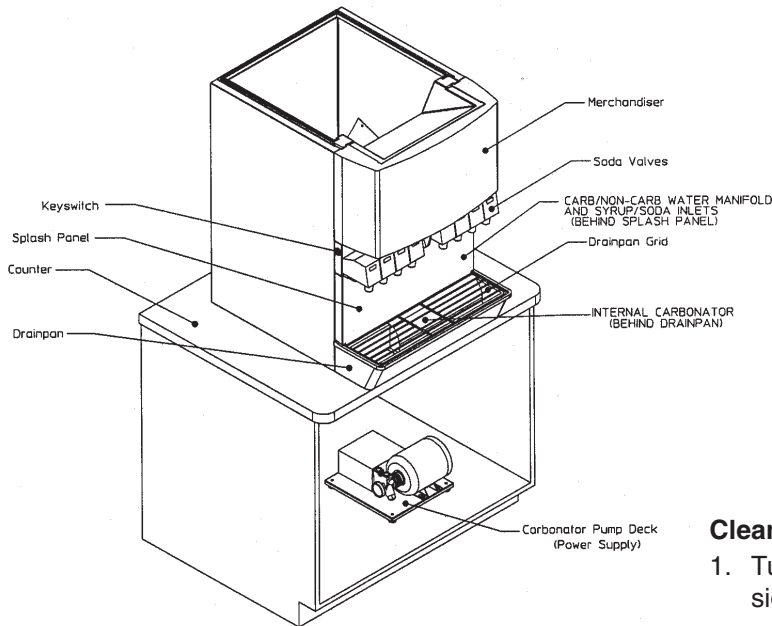

⚠ WARNING

UNPLUG UNIT BEFORE SERVICING OR CLEANING

ELECTRIC SHOCK HAZARD

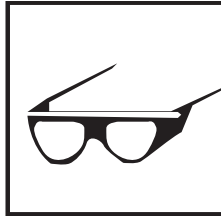

⚠ WARNING

When using cleaning fluids or chemicals, rubber gloves and eye protection should be worn

Clean the exterior and drain pan:

1. Turn off the key switch located on either right or left side of the unit.
2. Lift the grid and remove it from the drain pan.
3. Using mild soap, warm water and a clean cloth, wipe the drain pan and splash panel. Then, rinse with clean, warm water. Allow plenty of warm (not hot) water to run down the drain of the drain pan, to remove syrup residue that can clog the drain opening.
4. Wash the grid, then rinse with clean water. Place the grid back in the drain pan.
5. Wash all exterior surfaces of the unit with warm water and a clean cloth. Wipe again with a clean, dry cloth.

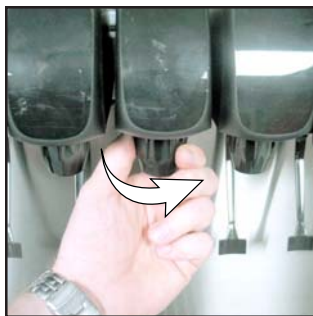

Clean the dispensing valves:

6. Remove nozzles and diffusers from beverage valves.
7. Rinse nozzle and diffuser with warm, clean water.
8. Clean nozzles and diffusers with soapy water and a soft bristle brush.
9. Clean the underside of the beverage valves with warm, soapy water. Rinse with clean damp towel.
10. Replace nozzles and diffusers on valves.
11. Turn on the key switch.

USER MAINTENANCE

MONTHLY CLEANING

Clean and sanitize the ice bin and cold plate:

1. Unplug unit and remove all ice from the ice bin.
2. Mix a solution of mild detergent to clean the dispenser bin and components.
3. Wash the ice bin using a sponge and the mild detergent solution.
4. Using the mild detergent solution and a soft bristle brush or clean cloth, clean the following dispenser parts:
 - Cold plate
 - Entire bin
 - Paddle wheel
 - Paddle wheel area
 - Agitator
 - Paddle wheel pin
 - Ice Chute
 - Rear bushing
 - Motor shaft
 - Strip lids (where applicable)

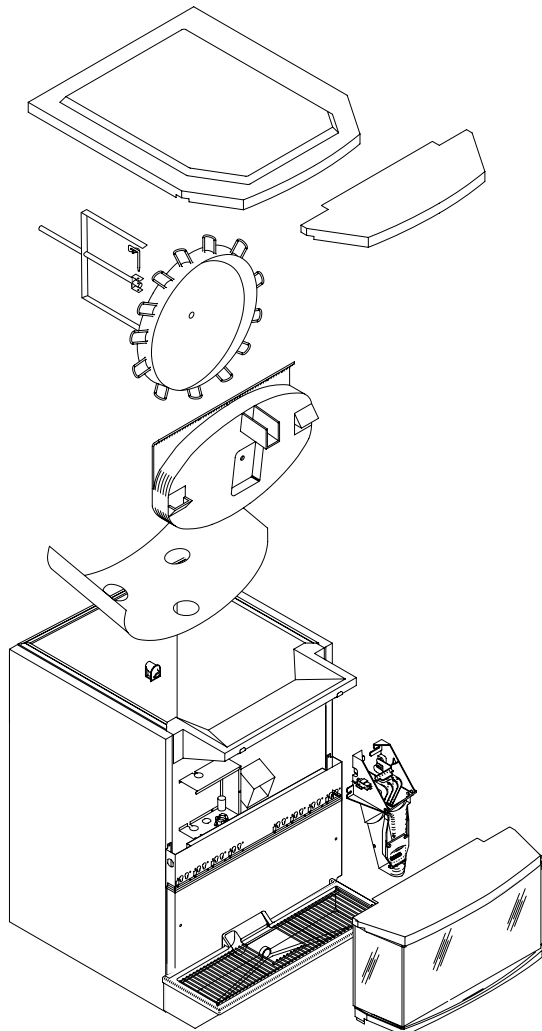
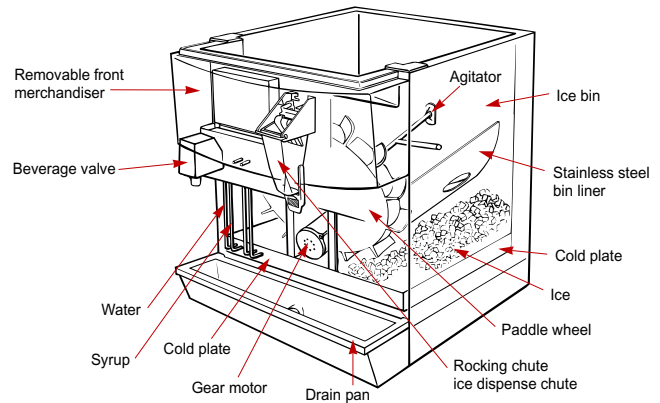
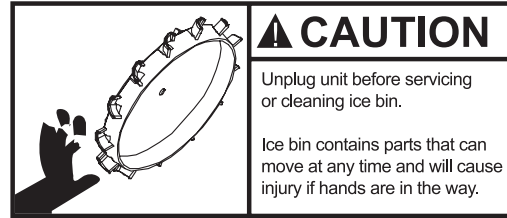

5. Rinse all the parts in clean, running water.
6. Prepare 2 gallons of sanitizing solution by mixing a $\frac{1}{2}$ ounce of household bleach (that contains 5.25% sodium hypochlorite) with 2 gallons of 120°F water. The mixture should not exceed 100 PPM of chlorine. Or mix a solution of any approved sanitizer, following the directions for mixing and applying the sanitizer..
7. Sanitize the ice bin and cold plate with the sanitizing solution for at least 10 seconds.
8. Allow to air dry. Do not rinse.

Reassembling the dispenser parts:

9. Reassemble parts in the following order:
 - Bin liner
 - Paddle wheel
 - Agitator
 - Paddle wheel pin
 - Ice chute
 - Merchandiser
10. Hand tighten all knurled fasteners.
11. Pour in fresh, sanitary ice and replace the plastic lid on the top of the dispenser.
12. Plug in the unit's electrical cord.
13. Check for proper ice dispensing.

USER MAINTENANCE

BEVERAGE SYSTEM CLEANING

 WARNING
Flush sanitizing solution from syrup system Residual sanitizing solution left in system could create a health hazard

 WARNING	
When using cleaning fluids or chemicals, rubber gloves and eye protection should be worn	

Sanitize the beverage system at initial start-up as well as regularly scheduled cleaning. The drain pan must be in place under soda valves, to carry away detergent and sanitizing agents that will be flushed through valves.

BAG-IN-BOX SYSTEM

The procedure below is for the sanitation of one syrup circuit at a time. Repeat to sanitize additional circuits.

You will need the following items to clean and sanitize the Bag-in-Box (BIB) beverage system:

- Three (3) clean buckets
- Plastic brush or soft cloth
- Mild detergent
- Unscented bleach (5% Na CL O) or Commercial sanitizer
- Bag-In-Box bag connector

1. Prepare the following in the buckets:
 - **Bucket 1** - warm to hot tap water for rinsing.
 - **Bucket 2** - mild detergent and warm to hot water.
 - **Bucket 3** - mix a solution of unscented bleach (5% Na CL O) or commercial sanitizer and warm to hot water. Mixture should supply 100 PPM available chlorine ($\frac{1}{4}$ oz. bleach to 1 gallon water).
- ② Disconnect the “syrup-line side” of the bag-in-box connector.
3. Rinse connector with warm tap water.
- ④ Connect syrup connector to BIB connector and immerse both into Bucket 1. A “bag-side” connector can be created by cutting the connector from an empty disposable syrup bag.
5. Draw rinse water through system until clean water is dispensed. Most beverage valves allow the syrup side to be manually activated by depressing the syrup pallet.
6. Connect Bucket 2 to system.
7. Draw detergent solution through system until solution is dispensed.
8. Repeat steps 2-7 until all syrup circuits contain detergent solution.
9. Allow detergent solution to remain in the system for 5 minutes.

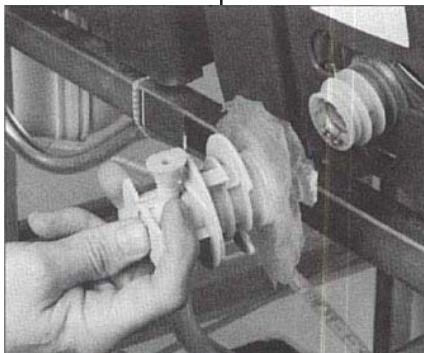
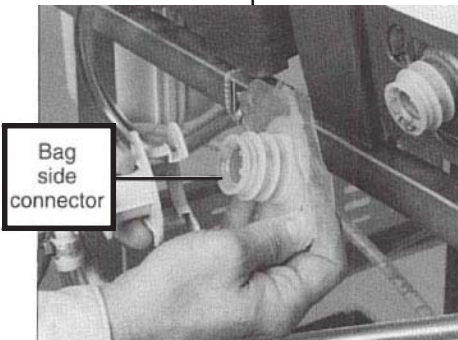
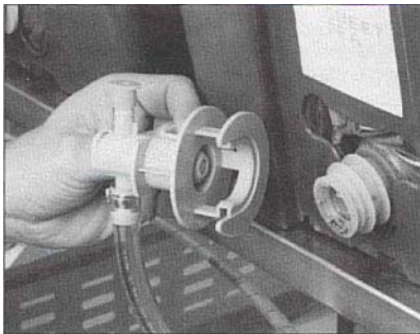

USER MAINTENANCE

BAG-IN-BOX SYSTEM

10. Connect Bucket 3 to system.
11. Draw sanitizing solution through system until solution is dispensed.
12. Repeat step 11 until all syrup circuits contain sanitizer solution.
13. Allow sanitizer solution to remain in system for 15 minutes.
14. Remove nozzles and diffusers from beverage valves.
15. Scrub nozzles, diffusers and all removable valve parts (except electrical parts) with a plastic brush or a soft cloth and the detergent solution.
16. Soak nozzles, diffusers and removable valve parts (except electrical parts) in sanitizer for 15 minutes.
17. Replace nozzles, diffusers and valve parts.
18. Connect Bucket 1 to system.
19. Draw rinse water through system until no presence of sanitizer is detected.
20. Attach syrup connectors to BIB's.
21. Draw syrup through system until only syrup is dispensed.
22. Discard first 2 drinks.

FIGAL BEVERAGE SYSTEM

1. Prepare the following in three clean Figal tanks:
 - **Rinse tank** - fill with room temperature tap water.
 - **Detergent tank** - mix approved beverage system cleaner with warm water as directed.
 - **Sanitizing tank** - mix a solution of unscented bleach (5% Na CL O) or commercial sanitizer and warm to hot water. Mixture should supply 100 PPM available chlorine ($\frac{1}{4}$ oz. bleach to 1 gallon water).
2. Disconnect all product and water lines from product tanks and remove carbonator.
3. Locate the Figal syrup tank for the circuit to be sanitized. Remove both quick disconnects from the Figal syrup tank. Rinse quick disconnects in tap water.
4. Connect rinse tank to the syrup line. Draw clean rinse water through the valve until syrup is flushed from the system.
5. Connect detergent tank to the syrup line and draw detergent through the valve for two minutes. Then, allow remaining detergent to stay in the system for five minutes.
6. Connect rinse tank to the syrup line. Draw clean rinse water through the valve until detergent is flushed from the system.
7. Remove valve nozzle and diffuser as shown in Daily Cleaning instructions on Pages 25 and 26. Using a plastic brush or a soft cloth and warm water, scrub the nozzle, diffuser, bottom of the dispensing valve and cup lever, if applicable.
8. Place removable valve parts (EXCEPT solenoids) in sanitizing solution for 15 minutes.
9. Replace valve diffuser and nozzle on the beverage valve.
10. Connect sanitizer tank to the syrup line and draw sanitizer through the valve for two minutes. Allow sanitizer to remain in the system for a minimum of 15 minutes.
11. Reconnect syrup and carbonated water lines.
12. Draw syrup through the lines to rinse the system. Discard drinks until at least two cups of satisfactory tasting beverage are dispensed through the valve.

TROUBLESHOOTING

PUMP

PROBLEM	POSSIBLE CAUSE	CORRECTIVE ACTION
Pump motor does not pump.	<p>Black and/or red probe shorted</p> <p>Problem with motor or motor wiring</p> <p>Problem with Liquid Level Control Board.</p> <p>Water pressure from water source is not high enough.</p>	<p>Remove probes and bend straight or replace with new probe(s)</p> <p>Check line voltage first. Check AC voltage across load terminals on Liquid Level Control. If voltage is 120 plus or minus 10%, replace motor or motor wiring.</p> <p>Check line voltage first. If AC voltage across load terminals is not 120 plus or minus 10%, replace the Liquid Level Control Board.</p> <p>Verify water pressure leading into pump inlet is 40 psi minimum with pump running.</p>
Pump will not run but tank appears to be always full.	Common Lead (Green) shorted out to Red wire (High Probe)	Verify Green and Red wires are not touching.
Pump will not run but tank level appears to be below start level.	Common Lead (Green) shorted out to Black wire (Low Probe)	Verify Green and Black wires are not touching.
Pump motor does not shut off.	<p>Problem with Liquid Level Control Board</p> <p>Probe Harness Connection may be open.</p> <p>Water may not be reaching top probe in carb tank.</p> <p>High Lead (Red) open or not connected.</p> <p>Common lead (Green) open or not connected.</p>	<p>Short the "H & L" terminals on the Liquid Level Control Board. If motor does not shut off, replace Liquid Level Control Board.</p> <p>Verify connections are good or replace the wiring harness.</p> <p>Verify tank is not filled with CO₂ or air by pulling relief valve up and letting air escape until water begins coming out.</p> <p>Verify Red lead wire is connected from tank to unit.</p> <p>Verify Green lead wire is connected from tank to unit.</p>
Pump motor intermittent	<p>Problem with probe or probe harness.</p> <p>Problem with motor or motor wiring.</p>	<p>Check motor and motor wires by removing red and black wires from the Liquid Level Control Board. If okay, short "H & L" terminal on Liquid Level Control Board. If motor stays off, verify probes and bend straight or replace. Verify with meter.</p> <p>Measure AC voltage across load terminals on Liquid Level Control Board. If line voltage is 120 plus or minus 10% replace motor or motor wiring.</p>

TROUBLESHOOTING

PUMP

PROBLEM	POSSIBLE CAUSE	CORRECTIVE ACTION
Pump motor intermittent	Problem with Liquid Level Control Board.	Check line voltage first. If AC voltage across load terminals on Liquid Level Control Board is not 120 plus or minus 10%, replace the Liquid Level Control board.
Pump motor starts and stops, short cycles, as soon as water level drops below Red (High) probe.	Black (Low) Lead wire is open or disconnected.	Verify connections and continuity of black wire from Liquid Level Control Board to Probes on Carb Tank.
Pump motor starts and stops, short cycles, as soon as water level drops below Black (Low) probe.	Red and Black Leads are switched with each other.	Verify Red Lead is going to Red probe and Black Lead is going to Black probe.
Pump short cycles from below high probe to just above high probe - Low probe has no effect.	Red and Green Leads are switched with each other. Black and Green Leads are switched with each other.	Verify Red Lead is going to Red Probe and Green Lead is going to Ground Screw on tank. Verify Black Lead is going to Black Probe and Green Lead is going to Ground Screw on tank.

DRINKS

CONDITION	INVESTIGATION	CHECK	CORRECTION
Warm drinks	Is the compressor running? No	Power switch off or Compressor switch off	Move switch to "on" position
		Ice bank control	Check / replace control box
		Compressor overload	Check / replace overload
		Start relay	Check / replace relay
		Compressor	Check / replace compressor
Note A: It is important to remember that anytime the refrigeration system is opened the refrigerant should be recovered, a new drier installed and the proper charge of refrigerant weighed into the refrigeration system.			
No water, syrup or gas dispensing	Is there power to the unit?	No power	Plug in unit or reset breaker
		Power to control box	Replace fuse or control box
	Is power coming through the key switch?	Key switch "off"	Turn switch "on"
		Key switch defective	Replace key switch
Is there power to the key switch?	No power through the transformer	Reset/replace transformer	

TROUBLESHOOTING

DRINKS

CONDITION	INVESTIGATION	CHECK	CORRECTION
Water only dispensing	No pressure	Regulator(s) out of adjustment	Check/adjust regulator(s)
		Out of CO ₂	Install fresh tank
		Defective regulator(s)	Check/repair/replace regulator(s)
		CO ₂ line pinched, kinked or obstructed	Check/repair/replace CO ₂ line
Syrup and CO ₂ only dispensing	Carbonator	No power	Check power supply. Plug in carbonator or reset breaker.
		Water supply	Make sure water is turned "on"
			Replace water filter
			Check/clean/replace pump strainer
			Check/clean/repair water check valve
		Check for frozen water line. Internal Carbonator unit only.	
Defective carbonator	Check/repair/replace carbonator pump, motor, electrode or liquid level control.		
Syrup and plain water only dispensing	No pressure	Out of CO ₂	Install fresh tank
		HP regulator out of adjustment	Adjust HP regulator to the proper setting
		Defective HP regulator	Check/repair/replace HP regulator
		CO ₂ line pinched, kinked or obstructed	Check/repair/replace CO ₂ line
One valve will not dispense anything	Is there power to the valve?	Broken wire or loose connection	Replace/repair wire or connector
		Bad microswitch	Replace microswitch
Beverage dispensed is too sweet	Is the ratio (brix) of the drink correct?	Flow control out of adjustment	Adjust the flow control
		Insufficient soda flow due to low carbonator pressure	Adjust CO ₂ pressure or change the tank
		Low CO ₂ pressure due to leaks	Repair CO ₂ leaks
		Obstruction in the water or soda line	Clean out the lines
Beverage is not sweet enough	Is the ratio (brix) of the drink correct?	Flow control out of adjustment	Adjust the flow control
		Soda flow too high	Reset CO ₂ pressure or replace regulator if necessary
		Obstruction in syrup line	Clean out the syrup line
Drinks are foaming	Are system pressures correct?	Over carbonation	Check CO ₂ supply. Reset pressure or replace regulator if necessary
		Dirty lines/valves	Clean/sanitize entire system

TROUBLESHOOTING

LIQUID LEVEL CONTROL

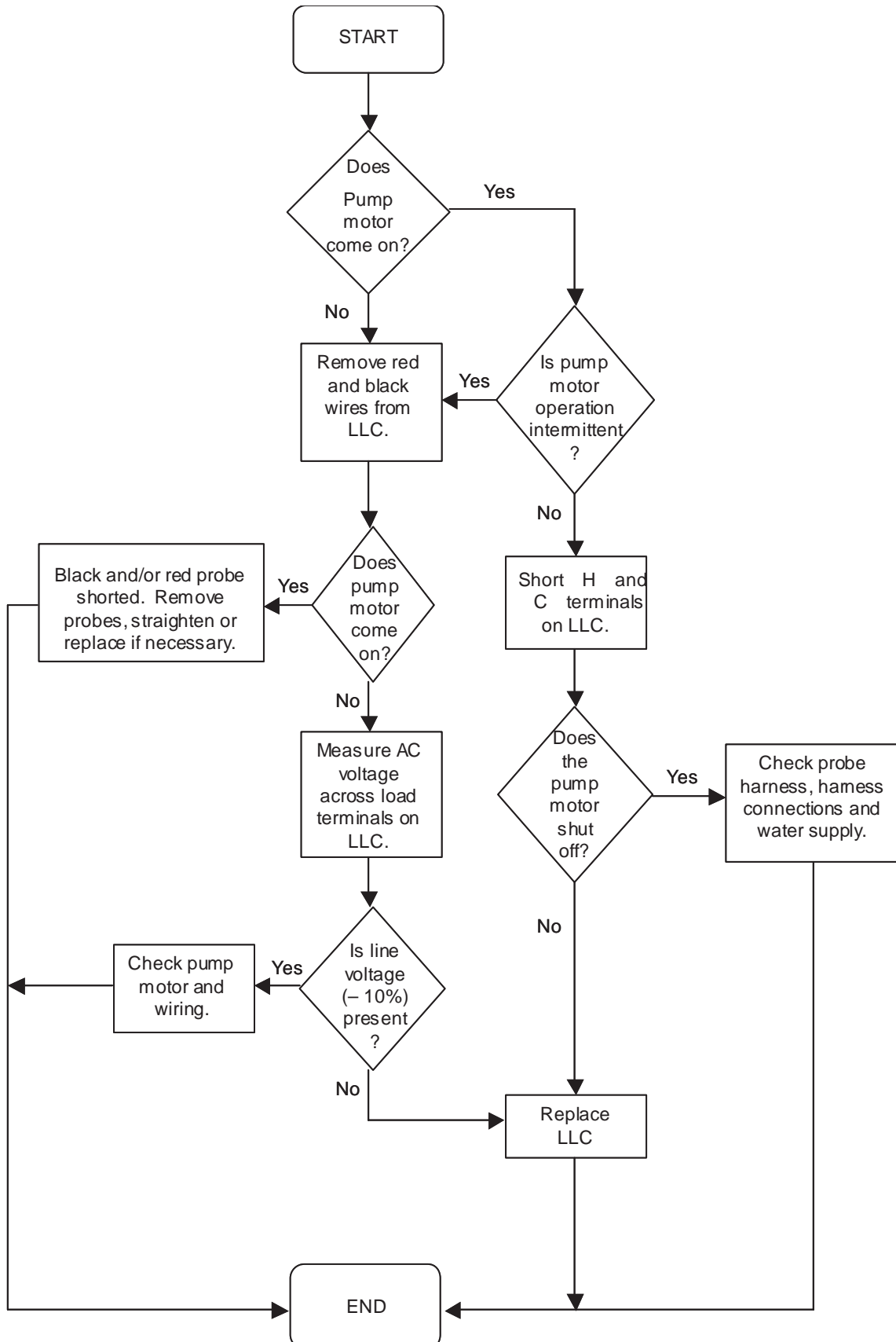

DO NOT USE

***Under
Preventative
Maintenance***

Please post this page in front of dispenser when cleaning system.



INDEX

B	F	O	T
Back Room Package 25	FOREWORD 2	Operation 6	TROUBLESHOOTING 57, 58, 59, 60
brixing 2	H	P	U
C	health department 38	Power outlet 8	Unit Inspection 23
Carbon Dioxide 6	I	Q	UNPACKING 2
CAUTION 9, 28, 31, 39	INSPECTION 2	Qualified Service Personnel 6	W
claims 23	INSTALLATION	R	Warning 6
Cleaning 2	8 9 10 11 12 13 14 15 16 17 18 19 20 21 22	regulations 38	WARRANTY INFORMATION 2
CO2 7	Installation Date 2	Relocation 6	water-to-syrup ratio. <i>See</i> brixing
CO2 monitors 7	Instructions 38	return procedures 2	Wiring Diagrams
D	irregularities 2	S	48, 49, 50, 52, 53, 55, 56
damage 2, 23	L	SAFETY 6, 7	
delivery 2, 23	location 8	sanitizing 7	
Diagrams	M	Serial Number 2	
42 43 44 45 46 47 48 49 50 51 52 53 54 55 56	MBE 2	service assistance 2	
dispensing valves 38	Model Number 2	Service Personnel 6	
distributor 2	modifications 6	Shipping 6	
Drain 8	Monthly Cleaning 39	Shipping, Storage, Relocation .. 6	
ducts 8		soapy water 39	
E		solvents 39	
exterior 38		start-up 6	
		Storage 6	



Multiplex

645 Park East Blvd, Suite 5 • New Albany, IN 47150
Tel: 844.724.2273 • Fax: 812.246.7020
www.multiplexbeverage.com

In accordance with our policy of continuous product development and improvement, this information is subject to change at any time without notice.