



MDH-302/402 & icepic™ / Selectable Ice Series Ice & Beverage Dispensers

Installation, Use & Care Manual

This manual is updated as new information and models are released.
Visit our website for the latest manual. www.multiplexbeverage.com

Safety Notices

As you work on Multiplex equipment, be sure to pay close attention to the safety notices in this manual. Disregarding the notices may lead to serious injury and/or damage to the equipment.

Throughout this manual, you will see the following types of safety notices:

Warning

Text in a Warning box alerts you to a potential personal injury situation. Be sure to read the Warning statement before proceeding, and work carefully.

Caution

Text in a Caution box alerts you to a situation in which you could damage the equipment. Be sure to read the Caution statement before proceeding, and work carefully.

Procedural Notices

As you work on Multiplex equipment, be sure to read the procedural notices in this manual. These notices supply helpful information which may assist you as you work.

Throughout this manual, you will see the following types of procedural notices:

Important

Text in an Important box provides you with information that may help you perform a procedure more efficiently. Disregarding this information will not cause damage or injury, but it may slow you down as you work.

NOTE: Text set off as a Note provides you with simple, but useful, extra information about the procedure you are performing.

Read These Before Proceeding:

Caution

Proper installation, care and maintenance are essential for maximum performance and trouble-free operation of your Multiplex equipment. Read and understand this manual. It contains valuable care and maintenance information. If you encounter problems not covered by this manual, do not proceed, contact Multiplex. We will be happy to provide assistance.

Important

Routine adjustments and maintenance procedures outlined in this manual are not covered by the warranty.

Warning

PERSONAL INJURY POTENTIAL

Do not operate equipment that has been misused, abused, neglected, damaged, or altered/modified from that of original manufactured specifications.

NOTE: SAVE THESE INSTRUCTIONS.

We reserve the right to make product improvements at any time. Specifications and design are subject to change without notice.

Table of Contents

Section 1

General Information

Read This Manual	1-1
Unit Inspection	1-1
Model Numbers	1-1
How to Read a Model Number	1-1
Accessories	1-1
Baffle for Manitowoc® Ice Machine	1-1
Manual Fill Lid for Dispensers with an Ice Machine	1-1
Legs	1-2
Serial Number Location	1-2
Warranty Information	1-2

Section 2

Installation Instructions

General	2-1
Dimensions	2-1
MDH-302 & 402 Footprint	2-2
Location	2-3
Location Requirements for Top Mounted Ice Machine Installations	2-3
Pre-installation Checklist	2-4
Double Check	2-5
Also Consider The Location Of The Following Items Before Installation ..	2-5
Additional Checks for Top Mounted Ice Machine Installations	2-5
Assembly	2-6
Installing Baffle for Ice Machine Installations	2-6
Electrical	2-7
General	2-7
Minimum Circuit Ampacity	2-7
Electrical Requirements	2-7
Voltage	2-7
Minimum Circuit Amperage Chart	2-7
Grounding Instructions	2-7
Pump Deck Wiring	2-8
Water Supply	2-9
Recommended Plumbing	2-9
Diagram Location	2-9
MDH-302 12 Valve Plumbing Diagram	2-10
MDH-302 12 Valve Flex Manifold (1 per side)	2-10

Table of Contents (continued)

MDH-402 16 Valve Plumbing Diagrams	2-11
MDH-402 16 Valve Flex Manifold (1 per side)	2-11
MDH-402 20 Valve Plumbing Diagram	2-12
MDH-402 20 Valve Flex Manifold (1 per side)	2-12
CO2 System	2-13
Routing Internal Carb Tank Purge Tube	2-13
Drains	2-13
Step by Step Installation	2-14
General	2-14
Capacities	2-14
Specifications Chart	2-14
Unit Installation	2-14
System Pressures	2-14
ADA Key Pads	2-15
Starting Your Beverage System & Dispenser	2-16

Section 3 Operation

General System Overview	3-1
MDH-302 Cold Carbonation System	3-2
MDH-402 Cold Carbonation System	3-3
Component Identification	3-4
Sequence of Operation	3-4
Ice Recommended for Dispensing	3-4
Non-adjustable Agitation Timer	3-4
Ice Storage and Dispensing	3-5
Carbonation	3-5
Syrup Delivery System	3-6
B-I-B	3-7
Figal System	3-7
Operation Checks & Adjustments	3-8
Ice Delivery Switch Adjustment	3-8
Crushed or Cubed Default	3-8
Agitation Timer Operational Check	3-8

Section 4 Maintenance

Cleaning	4-1
Daily Cleaning	4-1
Monthly Cleaning	4-2
Cleaning Checklist	4-2

Table of Contents (continued)

Preventive Maintenance	4-3
Disassembly	4-3
Disassembly for Cleaning and Maintenance	4-3
Disassemble the Rocking Chute	4-4
Disassemble the Ice Crusher Assembly	4-4
Monthly Ice Crusher Assembly Cleaning	4-6
Reassemble the Ice Crusher Assembly	4-7
Gear Motor Removal	4-8
Sanitizing	4-10
Beverage System Cleaning	4-10
Bag-In-Box System Sanitation	4-10
Figal Beverage System	4-11
Shipping, Storage and Relocation	4-11
MDH Series Graphic Medallion Removal & Installation	4-12
Medallion Removal	4-12

Section 5

Before Calling for Service

Checklist	5-1
icepic™ Troubleshooting	5-2
Pump Troubleshooting	5-3
Selectable Ice Troubleshooting	5-3
Drink Troubleshooting	5-4
Liquid Level Control Troubleshooting	5-5

Section 1

General Information

Read This Manual

Multiplex developed this manual as a reference guide for the owner/operator and installer of this equipment. Please read this manual before installation or operation of the machine. A qualified service technician must perform installation and start-up of this equipment. Consult **Section 5** within this manual for service assistance.

If you cannot correct the service problem, call your Multiplex Service Agent or Distributor. Always have your model and serial number available when you call.

Your Service Agent _____

Service Agent Telephone Number _____

Your Local Multiplex Distributor _____

Distributor Telephone Number _____

Model Number _____

Serial Number _____

Installation Date _____

Unit Inspection

Thoroughly inspect the unit upon delivery. Immediately report any damage that occurred during transportation to the delivery carrier. Request a written inspection report from a claims inspector to document any necessary claim.



Warning

PERSONAL INJURY POTENTIAL

Do not operate equipment that has been misused, abused, neglected, damaged, or altered/modified from that of original manufactured specifications.

Model Numbers

This manual covers the following models:

Beverage/Ice Dispensers
MDH-302, MDH-402, MDH-302 CI, MDH-402 CI, MDH-402 SCI

HOW TO READ A MODEL NUMBER

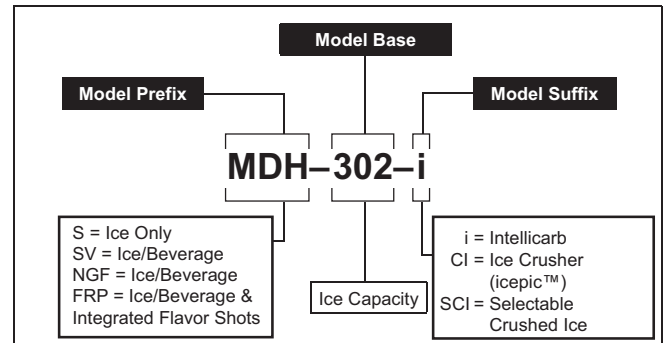

Accessories

BAFFLE FOR MANITOWOC® ICE MACHINE

When installing a Manitowoc Ice Machine on a dispenser, a baffle kit is required for proper installation. The baffle kit is designed to prevent ice from lying against the front of the ice machine, and melting down the front of the dispenser. There are two different baffle kits available for "S" series ice machines, one kit is for the 30" wide machine, and the other kit is for the 22" wide machine. There is also a kit for "Q" series ice machines.

Kits are available through your local distributor. List prices may be subject to change without notification. Please call your local parts distributor for current pricing before ordering.

MANUAL FILL LID FOR DISPENSERS WITH AN ICE MACHINE

If you are top mounting your dispenser with an ice machine, you will require a lid for the manual fill area at the top, front of the dispenser.

If you ordered a dispenser and an ice machine at the same time, the manual fill lid was included with the unit. The manual fill lid can be ordered from your local distributor.

LEGS

Legs are optional equipment with most Multiplex dispensers. Standard legs are 4" (10.2 cm) tall stainless steel legs. If an ice machine is installed on top of the dispenser, legs must not be installed. We do not recommend using legs when an ice machine is mounted on the dispenser. The combined weight of the dispenser, ice and ice machine is more evenly distributed when the base area of the dispenser is in contact with the countertop.

Serial Number Location

This number is required when requesting information from your local distributor. The serial number is listed on the SERIAL NUMBER DECAL affixed to the dispenser.

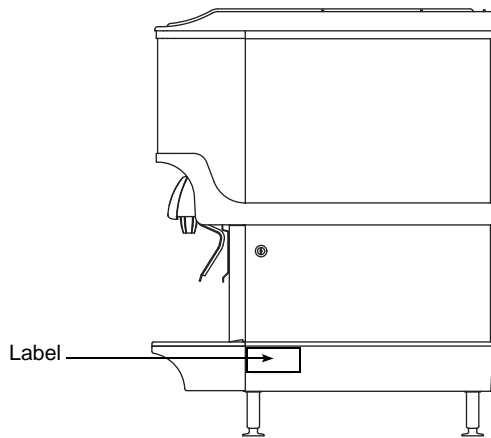

Serial Number Location

Warranty Information

Consult your local Multiplex Distributor for terms and conditions of your warranty. Your warranty specifically excludes all beverage valve brixing, general adjustments, cleaning, accessories and related servicing.

Your warranty card must be returned to Multiplex to activate the warranty on this equipment. If a warranty card is not returned, the warranty period can begin when the equipment leaves the Multiplex factory.

No equipment may be returned to Multiplex without a written Return Materials Authorization (RMA). Equipment returned without an RMA will be refused at Multiplex's dock and returned to the sender at the sender's expense.

Please contact your local Multiplex distributor for return procedures.

Section 2 Installation Instructions

General

These instructions are provided to assist the qualified installer. Contact your Multiplex Service Agent or call Multiplex for information regarding start-up services.

Important

Failure to follow these installation guidelines may affect warranty coverage.

Dimensions

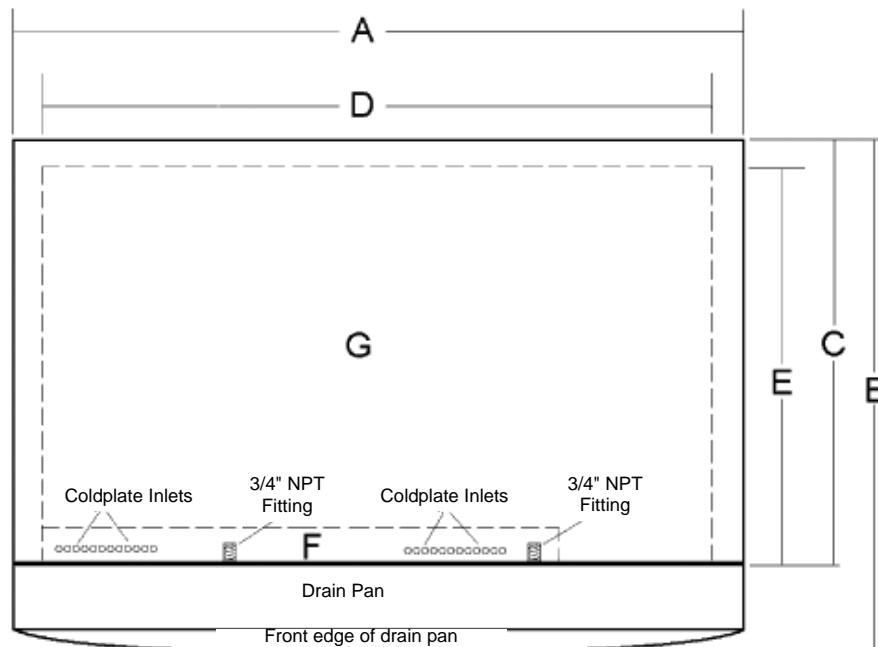

MODEL	A	B	C	D	E
MDH-302*	42.75" (108.59 cm)	30.50" (77.47 cm)	22.50" (57.15 cm)	38.75" (98.43 cm)	20.50" (52.07 cm)
MDH-402*	60.00" (152.40 cm)	30.50" (77.47 cm)	22.50" (57.15 cm)	56.50" (143.51 cm)	21.25" (53.98 cm)

* Applies to icepic™ models also (MDH-302 CI & MDH-402 CI)

MDH-302 & 402 Footprint

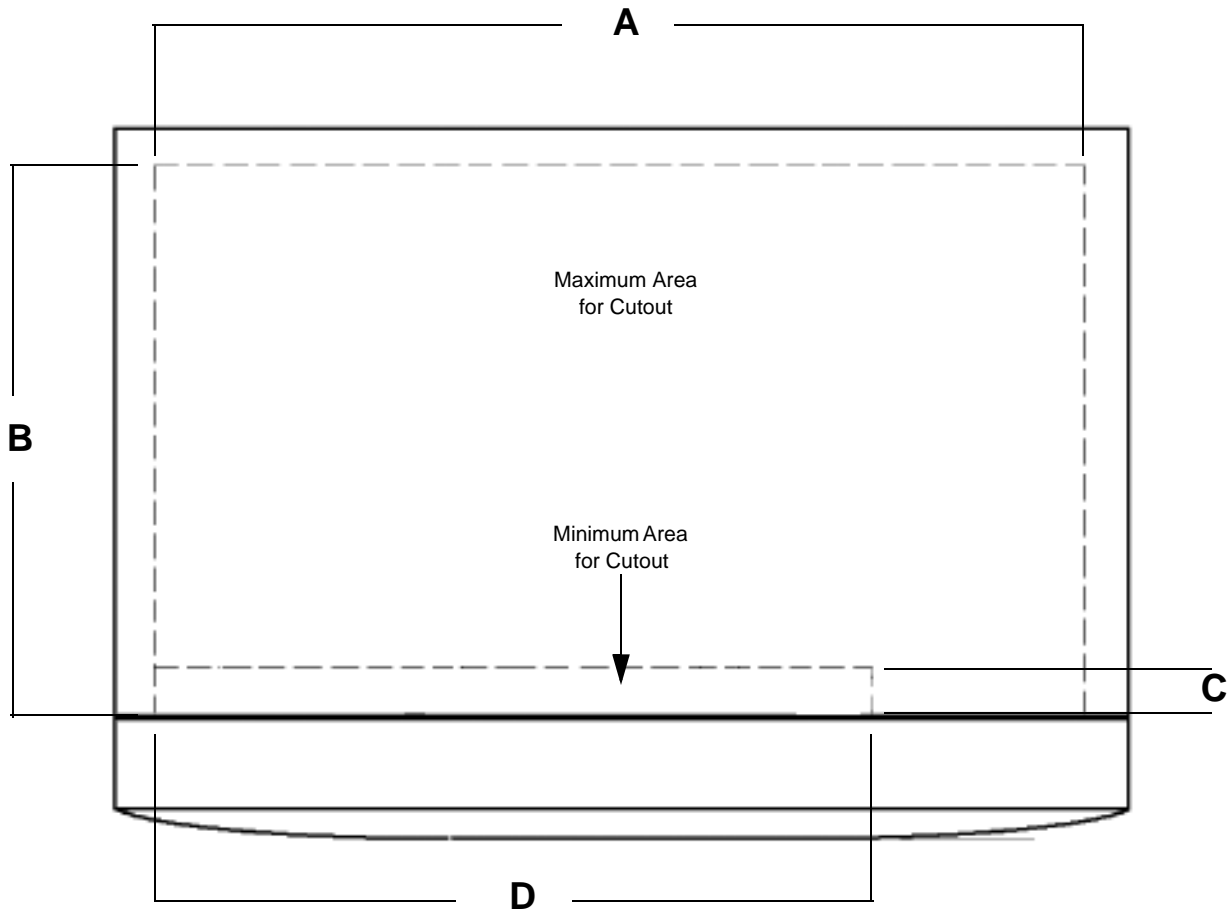

Model	Maximum		Minimum	
	A	B	C	D
MDH-302*	38.75" (98.43 cm)	20.50" (52.07 cm)	3.00" (7.62 cm)	32.00" (81.28 cm)
MDH-402*	56.50" (143.51 cm)	21.40" (54.36 cm)	3.00" (7.62 cm)	48.00" (121.92 cm)

⚠ Caution
 Cutting the countertop may decrease its strength. Counter must be braced to support the dispenser countertop weight plus ice storage capacity and weight of ice machine, if applicable.

* Applies to icepic™ models also (MDH-302 CI & MDH-402 CI)

Location

The location selected for the beverage dispenser must meet the following criteria. If any of these criteria are not met, select another location.

- The air temperature must be at least 50°F (10°C), but must not exceed 95°F (35°C).
- The location must not be near heat-generating equipment or in direct sunlight and must be protected from weather.
- The countertop must be level. Verify that the countertop can support the weight of the dispenser, or the dispenser/ice machine combination plus the weight of the stored ice.
- Water lines, drains and power outlet must be within 6' (1.8 m) of location.



Warning

Carbon Dioxide (CO₂) displaces oxygen. Exposure to a high concentration of CO₂ gas causes tremors, which are followed rapidly by loss of consciousness and suffocation. If a CO₂ gas leak is suspected, particularly in a small area, immediately ventilate the area before repairing the leak. CO₂ lines and pumps must not be installed in an enclosed space. An enclosed space can be a cooler or small room or closet. This may include convenience stores with glass door self serve coolers. If you suspect CO₂ may build up in an area, venting of the B-I-B pumps and / or CO₂ monitors must be utilized.

LOCATION REQUIREMENTS FOR TOP MOUNTED ICE MACHINE INSTALLATIONS

Location — Avoid placing the dispenser and/or ice machine near heat sources such as radiators, ovens, refrigeration equipment and direct sunlight.

Clearances — Refer to the ice machine installation manual for clearances.

Front of ice machine to be flush with front of dispenser — Some ice machines may overhang at the back of the dispenser.

Drains — A separate drain line is required for the ice machine, in addition to a drain line for the ice/beverage dispenser.

Dispensers may require an adapter kit to install some top-mounted ice machines. Contact your local distributor for the correct adapter kit.

For full information about ice machine installation, including clearances, plumbing lines, connections, and electrical requirements, see the ice machine installation manual.

Pre-installation Checklist

When installing any system, first make sure the major components are available. Generally the major components necessary for an installation are:

Pre-mix System:

- CO₂ regulator set
- Product connectors for Figal tank
- Gas connectors for Figal tank
- Beverage dispenser
- Beverage tubing
- CO₂ tank
- Figal beverage tanks
- Stepless (Oetiker) clamps
- Chain for CO₂ tank

B-I-B System also:

- B-I-B connectors
- B-I-B regulator set
- B-I-B rack
- B-I-B syrup boxes

Post Mix System:

- CO₂ regulator set
- Beverage dispenser
- Beverage tubing
- CO₂ tank
- Carbonator
- Stepless (Oetiker) clamps
- Chain for CO₂ tank

Figal System also:

- Syrup connectors for Figal tank
- Gas connectors for Figal tank
- Figal syrup tanks

Bulk Syrup System also:

- Syrup connectors for Bulk tank
- Gas connectors for Bulk tank
- Bulk syrup tanks

DOUBLE CHECK

- Do you have enough space to install the dispenser or a dispenser and top mounted ice machine?
- Does top mounted ice machine (if utilized) have a minimum of 6" (15.2 cm) clearance on all sides?
- Is the countertop level?
- Can the countertop support the weight of the dispenser, or the dispenser/ice machine combination plus the weight of the stored ice?

ALSO CONSIDER THE LOCATION OF THE FOLLOWING ITEMS BEFORE INSTALLATION

- Water line
- Drain
- Power outlet
- Heating and air conditioning ducts

ADDITIONAL CHECKS FOR TOP MOUNTED ICE MACHINE INSTALLATIONS

- Location** — Avoid placing the dispenser and/or ice machine near heat sources such as radiators, ovens, refrigeration equipment and direct sunlight.
- Clearances** — 6" (15.2 cm) clearance on all sides of the ice machine is needed.
- Front of ice machine to be flush with front of dispenser** — The front of the ice machine must be flush with the front of the dispenser. When the ice machine is flush with the front of the dispenser, some ice machines may overhang at the back of the dispenser.
- Drains** — A separate drain line is required for the ice machine, in addition to a drain line for the ice/beverage dispenser.
- Dispensers may require an adapter kit to install some top-mounted ice machines. Contact your local distributor for the correct adapter kit.

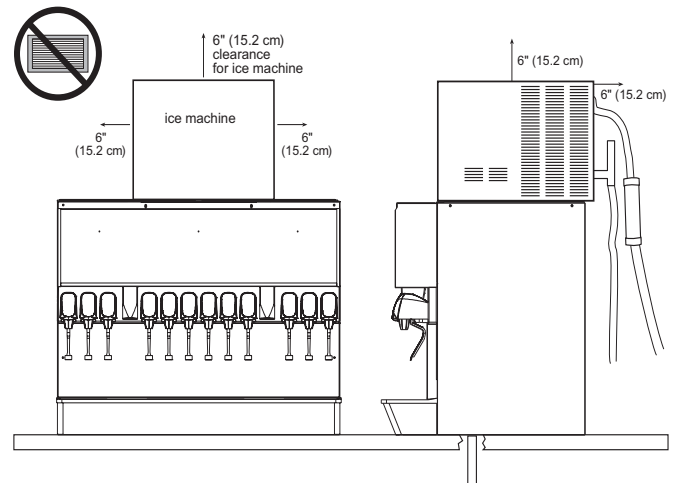

For full information about ice machine installation, including plumbing line connections and electrical requirements, see the ice machine installation manual.

Assembly

INSTALLING Baffle FOR ICE MACHINE INSTALLATIONS

“S” Series Baffle

1. Remove both front panels.
2. Examine the ice machine to see if the machine has four screws on the lower front plastic panels.
3. If there are screws, remove them from the countersunk holes on the front surface of the machine, save the screws.
4. Install the deflector, using the four screws removed in step three.
5. Four screws and two backing plates are in the kit.
6. If there are no screws on the ice machine (step 2), pierce the thin plastic countersunk holes, install the backing plates and install the deflector using the screws from the kit.
7. Replace the front panels.

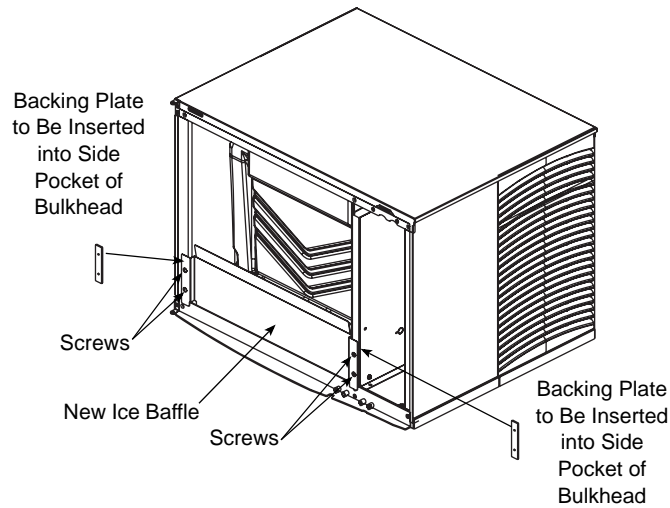

“S” Series Ice Machine

“Q” Series Baffle

1. Position baffle on top of water well with tab on the front and the other tab inside the water well.
2. Mount the baffle on the left side of the ice machine using the hole and screw provided.

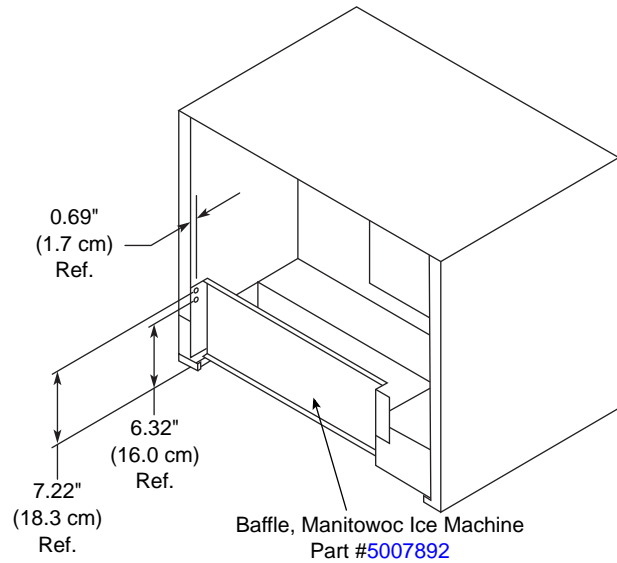

“Q” Series Ice Machine

Electrical

GENERAL

 **Warning**

All wiring must conform to local, state and national codes.

MINIMUM CIRCUIT AMPACITY

The minimum circuit ampacity is used to help select the wire size of the electrical supply. (Minimum circuit ampacity is not the beverage/ice machine's running amp load.) The wire size (or gauge) is also dependent upon location, materials used, length of run, etc., so it must be determined by a qualified electrician.

ELECTRICAL REQUIREMENTS

Refer to Ice Machine Model/Serial Plate for voltage/ amperage specifications.

VOLTAGE

The standard voltage for MDH Series dispensers is 120VAC - 60Hz. A power cord is provided with 120VAC - 60Hz models only. MDH Series dispensers use a 1/7 hp gearmotor.

MINIMUM CIRCUIT AMPERAGE CHART

Important

Due to continuous improvements, this information is for reference only. Please refer to the dispenser serial number tag to verify electrical data. Serial tag information overrides information listed on this page.

MDH-302/402 Dispensers	Voltage/Cycle	Minimum Circuit Amps
With Standard or 24" Extended Merchandiser (Non-crusher)	120/60	4.50 *
	220/60	2.25
34" Extended Merchandiser (Non-crusher)	120/60	5.00 *
	220/60	2.50
With Standard or 24" Extended Merchandiser (with Crusher)	120/60	5.25 *
34" Extended Merchandiser (with Crusher)	120/60	5.75 *

* Does not include carbonator motor.

Grounding Instructions

 **Warning**

Risk of electrical shock. Connect to a properly grounded outlet only.

This appliance must be grounded. In the event of malfunction or breakdown, grounding provides a path of least resistance for electric current to reduce the risk of electric shock. This appliance is equipped with a cord having an equipment-grounding conductor and a grounding plug. The plug must be plugged into an appropriate outlet that is properly installed and grounded in accordance with all local codes and ordinances.

 **Warning**

Improper connection of the equipment-grounding conductor can result in a risk of electric shock. The conductor with insulation having an outer surface that is green with or without yellow stripes is the equipment grounding conductor. If repair or replacement of the cord or plug is necessary, do not connect the equipment-grounding conductor to a live terminal. Check with a qualified electrician or serviceman if the grounding instructions are not completely understood, or if in doubt as to whether the appliance is properly grounded. Do not modify the plug provided with the appliance — if it will not fit the outlet, have a proper outlet installed by a qualified electrician.

 **Warning**

When using electric appliances, basic precautions should always be followed, including the following:

- a. Read all the instructions before using the appliance.
- b. To reduce the risk of injury, close supervision is necessary when an appliance is used near children.
- c. Do not contact moving parts.
- d. Only use attachments recommended or sold by the manufacturer.
- e. Do not use outdoors.
- f. For a cord-connected appliance, the following shall be included:
 - Do not unplug by pulling on cord. To unplug, grasp the plug, not the cord.
 - Unplug from outlet when not in use and before servicing or cleaning.
 - Do not operate any appliance with a damaged cord or plug, or after the appliance malfunctions or is dropped or damaged in any manner. Contact the nearest authorized service facility for examination, repair, or electrical or mechanical adjustment.
- g. For a permanently connected appliance — Turn the power switch to the off position when the appliance is not in use and before servicing or cleaning.
- h. For an appliance with a replaceable lamp — Always unplug before replacing the lamp. Replace the bulb with the same type.
- i. For a grounded appliance — Connect to a properly grounded outlet only. See Grounding Instructions.

PUMP DECK WIRING

The supply cord is equipped with a three prong 5-15P. When a Ground Fault Circuit Interrupter (GFCI) is required by code, a breaker type protector must be used. We do not recommend GFCI outlets as they are known for more intermittent nuisance trips than panel breakers. To ensure both the safety and proper operation of this equipment, be certain that the electrical receptacle is a proper design so as to accept this plug, ensuring that the carbonator assembly is properly grounded.

If the pump deck is to be installed in an area or community whose local codes require permanent wiring, the following procedure must be followed.

1. The three wires (white, black and green) must be fed through the cable connector and brought into the wiring compartment. The cable must be secured into the connector.
2. The green wire from the cable must be connected to the green screw that attaches to the inside panel of the wiring compartment. Be sure to use a ring torque terminal for connecting the wire to the screw.
3. The white wire from the cable must be joined to the N terminal of the liquid level control board by a suitable U.L. listed insulated cable connector.
4. The black wire from the cable must be joined to the L1 terminal of the liquid level control board by a suitable U.L. listed insulated cable connector.

Water Supply

RECOMMENDED PLUMBING

The plumbing diagram is printed on a white vinyl label, normally located above the inlet tubes for syrup and water. The plumbing diagram label can be accessed by removing the splash panel of the dispenser. The plumbing diagram label explains which inlet coldplate fittings supply which dispenser valves and water manifolds.

The water supply must first be connected to the carbonator pump (not shown) before plumbing to connection "A" shown on plumbing diagram. The carbonator pump deck must be within 6' (1.8 m) of the dispenser for optimum performance. See B-I-B installation diagram for system pressure settings.

A check valve must be installed in the water supply line 3' (0.9 m) from the noncarbonated water connection "PW". Contact factory if not installed.

DIAGRAM LOCATION

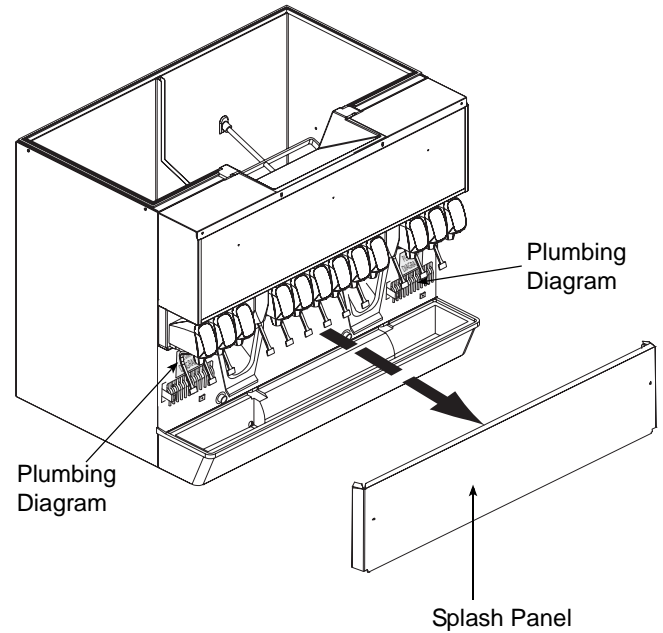

MDH-302 12 VALVE PLUMBING DIAGRAM

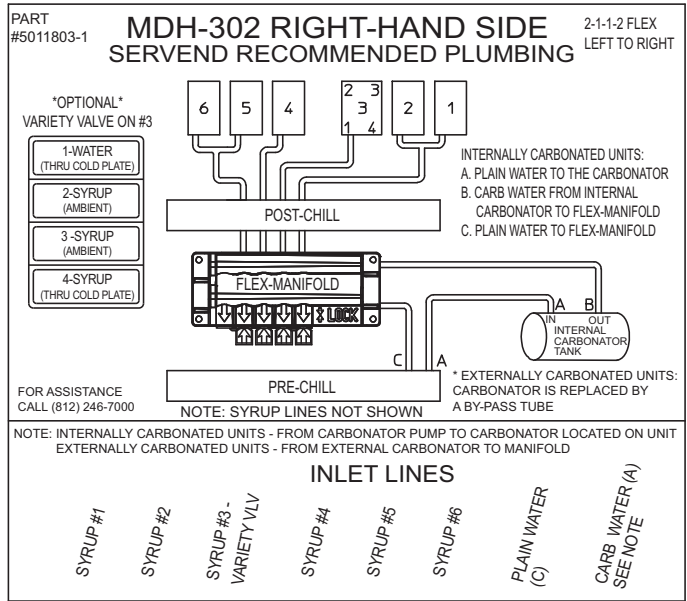
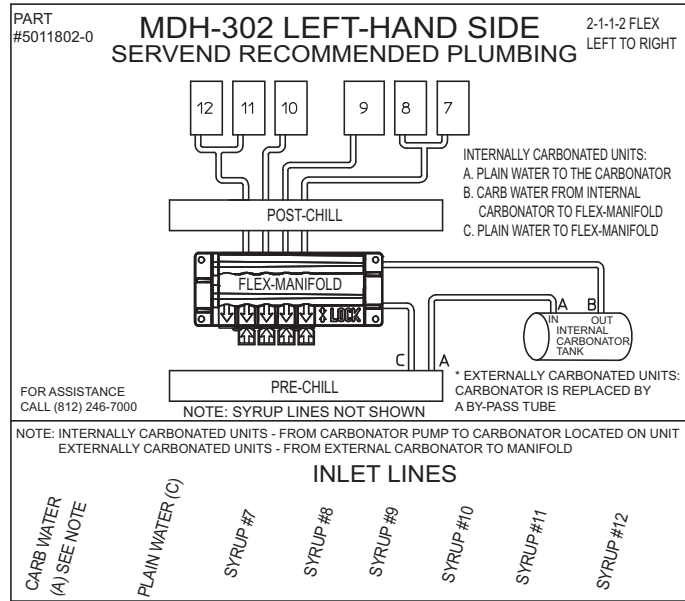

MDH-302 12 VALVE FLEX MANIFOLD (1 PER SIDE)

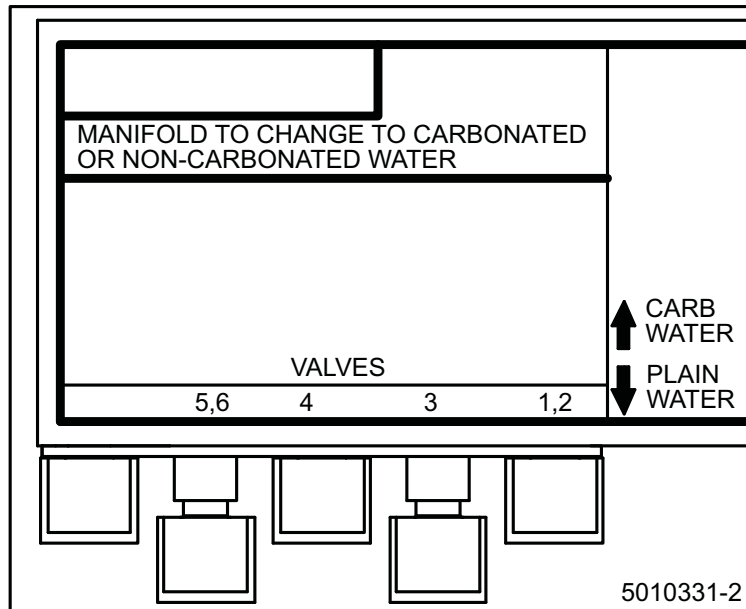

MDH-402 16 VALVE PLUMBING DIAGRAMS

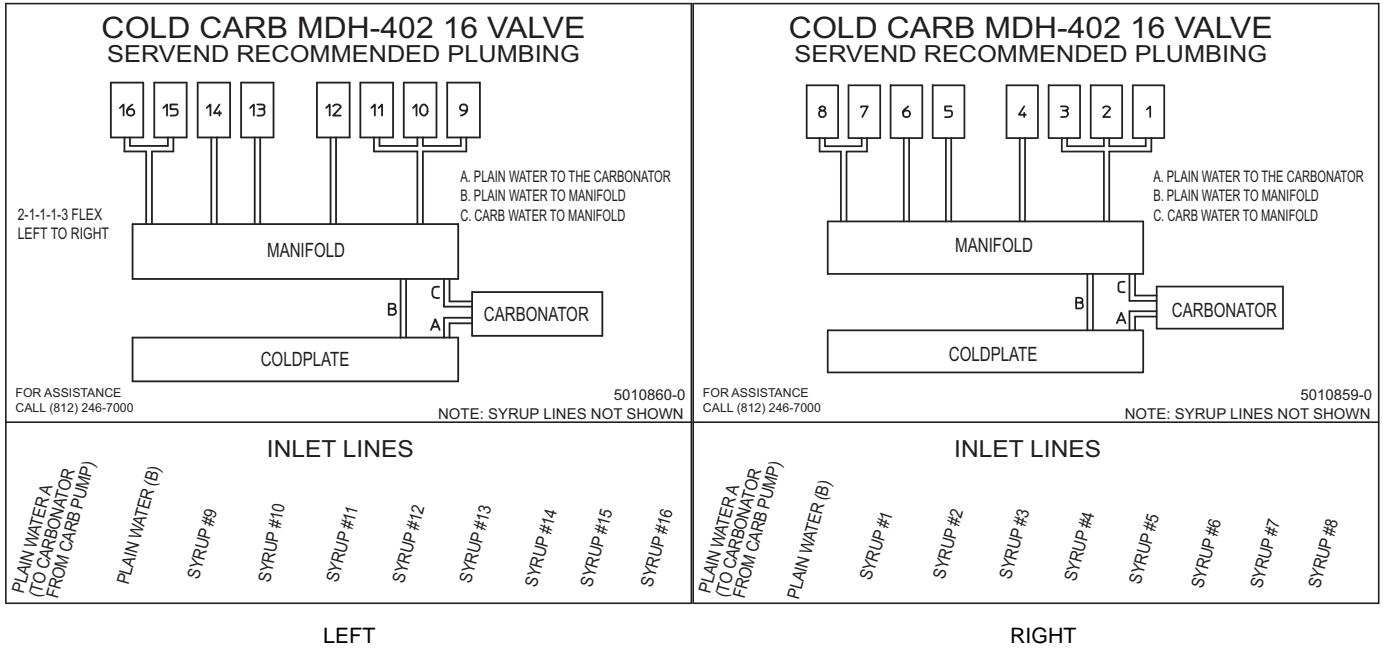

MDH-402 16 VALVE FLEX MANIFOLD (1 PER SIDE)

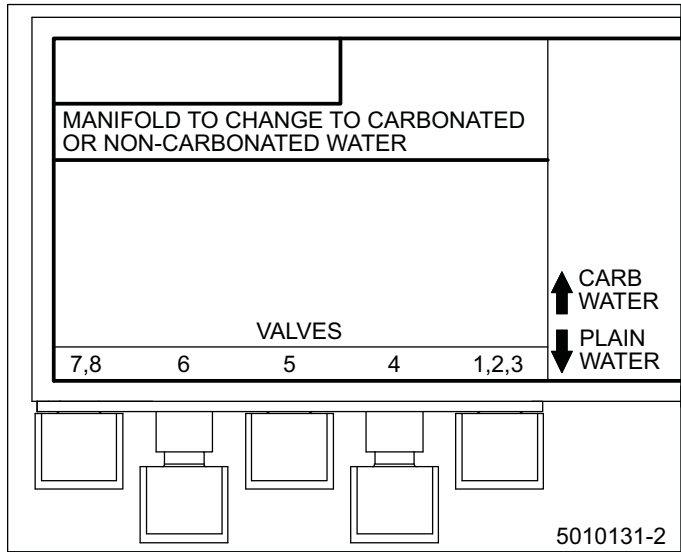

MDH-402 20 VALVE PLUMBING DIAGRAM

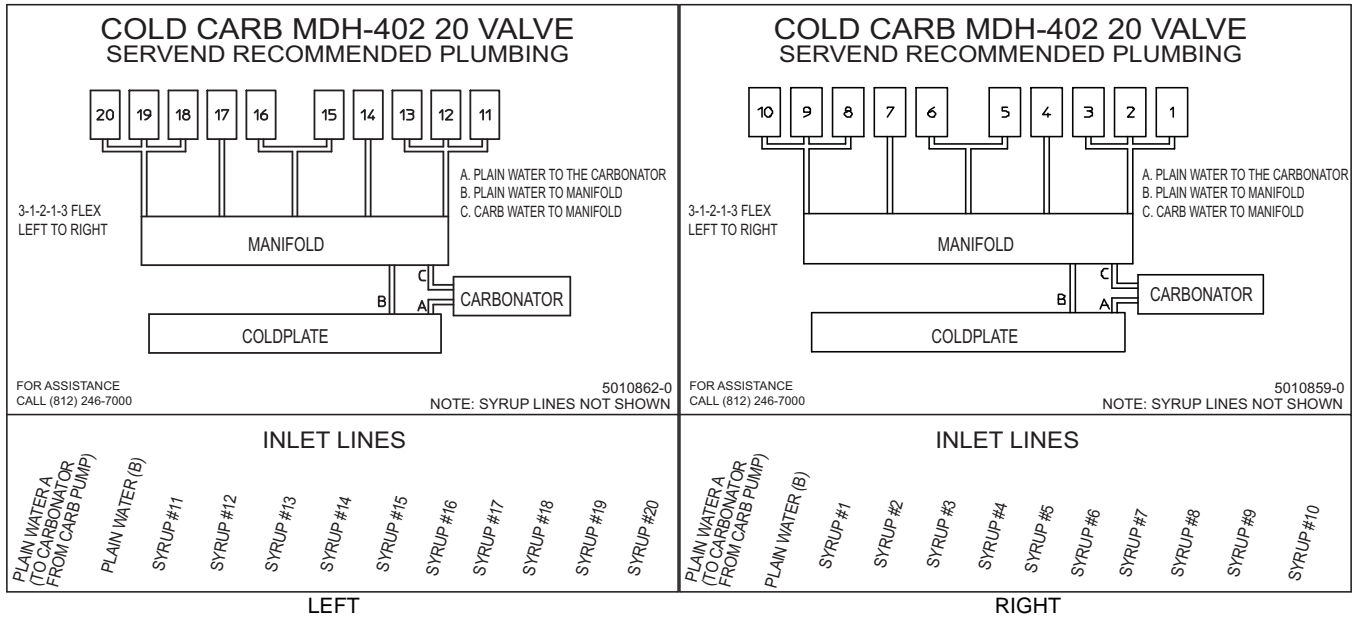

MDH-402 20 VALVE FLEX MANIFOLD (1 PER SIDE)

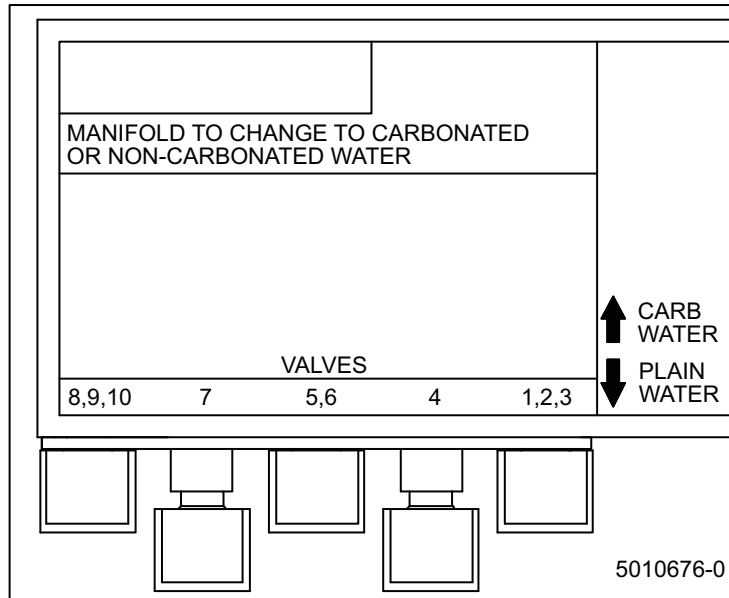

CO₂ System

ROUTING INTERNAL CARB TANK PURGE TUBE

Some models are equipped with an internal carbonation tank. These models require that the purge/pressure relief tubing be routed to a drain.

1. Remove the splash panel.
2. Uncoil tubing and route between the front of the dispenser and the drain pan.

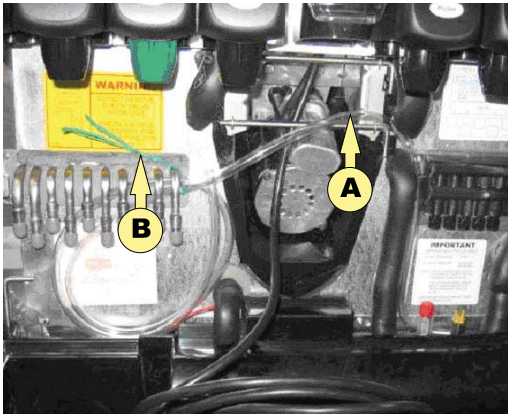

3. Depending on drain location route the tubing through the tubing bundle cutout or out the back of the dispenser.

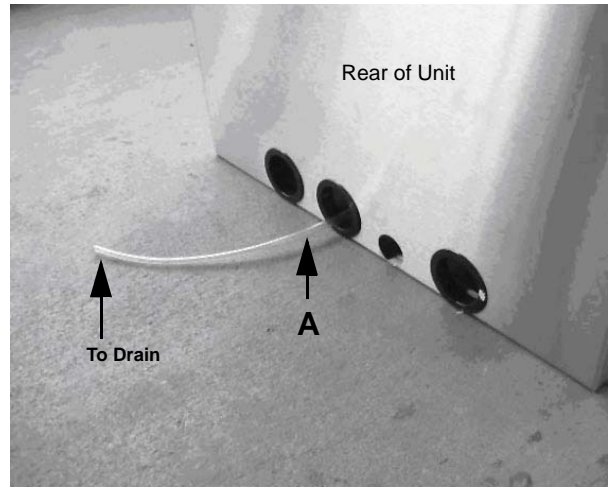

4. Verify the tubing is not kinked and then secure tubing to maintain a minimum 1" (2.5 cm) air gap at the drain. Follow any applicable local or national codes.

DRAINS

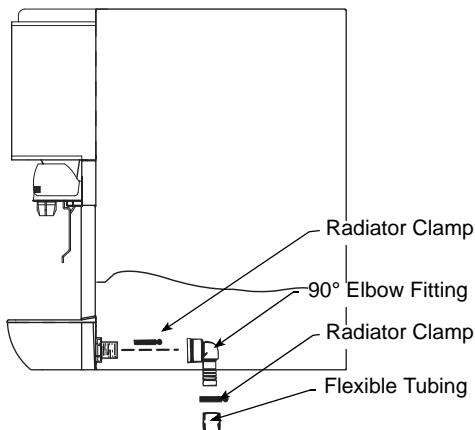

Drainage Through Bottom

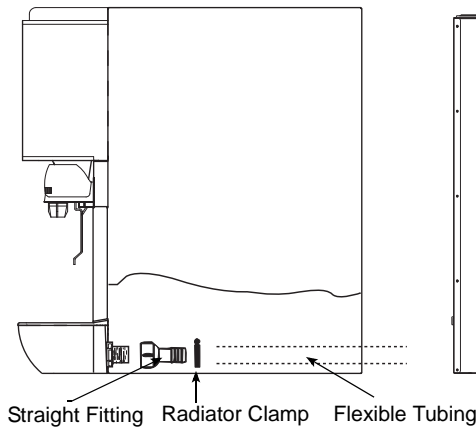

Drainage Through Back

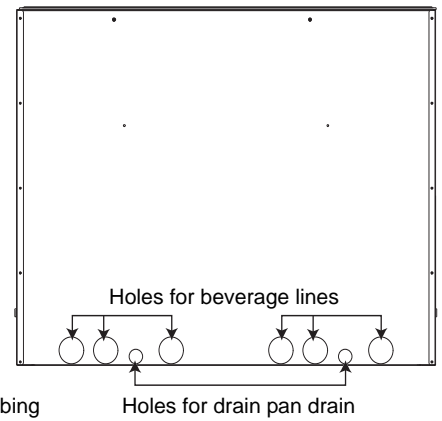

Rear View

Step by Step Installation

GENERAL

MDH series dispensers have a stainless steel cabinet and lighted merchandiser standard.

Beverage valves, coldplate connections, drain connections and electrical components are front serviceable.

CAPACITIES

Dispenser	Valves	Ice Storage
MDH-302	10 or 12	300 lbs
MDH-302 w/Extended Merchandiser	10 or 12	300 lbs
MDH-402	16 or 20	400 lbs
MDH-402 w/24" Extended Merchandiser	16 or 20	400 lbs
MDH-402 w/34" Extended Merchandiser	16 or 20	400 lbs

SPECIFICATIONS CHART

	MIN.	MAX
Incoming Plain Water Pressure	40 psi dynamic	70 psi static
Plain Water Pressure to Carb Tank	55 psi	65 psi
Ambient Temperature	40°F (4°C)	105°F (41°C)
CO ₂ Pressure (Primary)	90 psi	100 psi
Electrical	115V/60 Hz/1	230V/50-60 Hz/1
Pre-mix Pressure		
Normal	60 psi*	
Diet	40 psi*	
B-I-B (Secondary)	75 psi or according to line run	
Flavor Shots	30 psi or according to line run	

* This is the optimal pressure. For high foam, decrease the pressure, for spitting/popping, increase the pressure.

UNIT INSTALLATION

1. Place the dispenser in the desired location.

NOTE: The unit must be placed and operated in a horizontal, level position. This unit is not suitable for areas cleaned with a water jet, pressure washers or water hoses.

2. Run the beverage lines and water lines; make sure to install the water connections to the proper inlets. Connection "A" comes from the brass carbonator pump and connection "B" is the plain water supply.
3. Install plumbing drains and insulate.
4. Fill bin with ice.
5. Set flexible manifold for correct drink settings.
6. Turn water supply on to the dispenser.
7. Purge air from the carbonator tank. Lift the pressure relief valve tab on the carbonator tank until water comes out of the relief valve.
8. Connect the pump deck control lead to the pump motor.
9. Connect power supply cords. (There are 2 cords that need to be connected to a 115V power supply.)
10. Brix beverage valves.

SYSTEM PRESSURES

1. **Incoming tap water** - must be at a minimum dynamic pressure of 40 psi and maximum static pressure of 70 psi.

Important
If incoming water pressure is under 40 psi dynamic, a water booster is recommended. If incoming water pressure is over 55 psi, a water regulating valve is recommended.

NOTE: For water booster setups, connect directly to the incoming water to the unit. A regulator may be needed to maintain 40 - 55 psi to the carbonator or water may be routed around the booster to the carbonator. If water pressure is too high to the carbonator, poor drink carbonation can result.

Important
Water boosters are preset to turn on at 65 psi and off at 85 psi.

2. B-I-B pressure gauge must be set for 75 psi or according to your line run.
3. Carbonator Pressure gauge (Use Preset Regulator):
 - Cold Carbonation set for 75 psi.
 - Ambient systems must be set at 90 psi to 105 psi.

NOTE: For models with flavor shots you want to achieve 0.5 oz (14.787 cc) per second dispense, adjust secondary regulator or flow controls accordingly.

ADA KEY PADS

These instructions are for installations with this option.

1. Remove power from the unit.

Merchandiser Removal

2. Remove the medallion from merchandiser to gain access to the area above the valve mount cap. Medallions are removed through the top of standard merchandisers and either side of the extended merchandisers.

Splash Panel Removal

3. Remove the splash panel from the unit by removing the two (2) Phillips head screws holding it in place.

ADA Wiring

NOTE: Follow these instructions for the right and left sides of the unit.

4. Route the ADA ribbon cable under the drain pan.

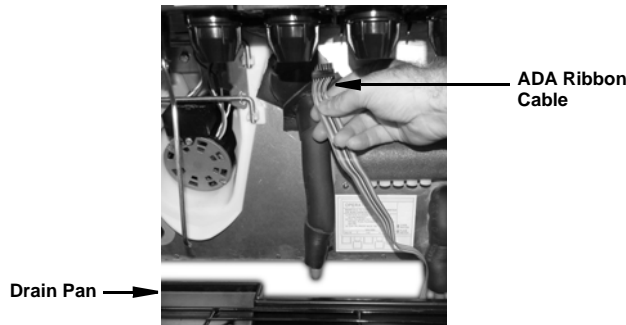

5. Locate the ADA harness, units with a crusher it will be on the left of the ice chute, non-crusher units will be on the right. Continue routing the ADA cable behind the valve mount cap up towards the ADA harness.



6. Connect the ADA ribbon cable to the ADA wire harness that is fastened to the foam front by a wire clip.



7. Neatly tuck in and take up any slack remaining in the ADA ribbon cable so it will not be in the way of any moving parts or panels when they are placed back on the unit.

Drain Pan & ADA Key Pad Box

8. Attach the drain pan to the unit.
9. Center the ADA Key Pad Box with the unit in front of the drain pan and secure into place.

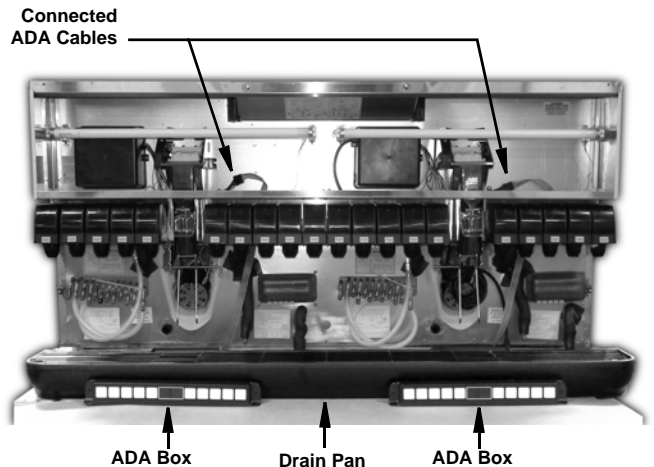

Important

If mounting the ADA Box directly in front of the drain pan on the countertop, leave a minimum of 1" (2.5 cm) space between the bottom edge of the drain pan and the ADA Box to allow space for drain pan removal.

10. Apply corresponding drink labels to the ADA key pads.

NOTE: If buttons are not used, they will be blanked out. The Cubed/Crushed buttons are only utilized on units configured with the Selectable Ice feature. (See ADA Key Pad Matrix Page 2-16)

ADA Key Pad Matrix

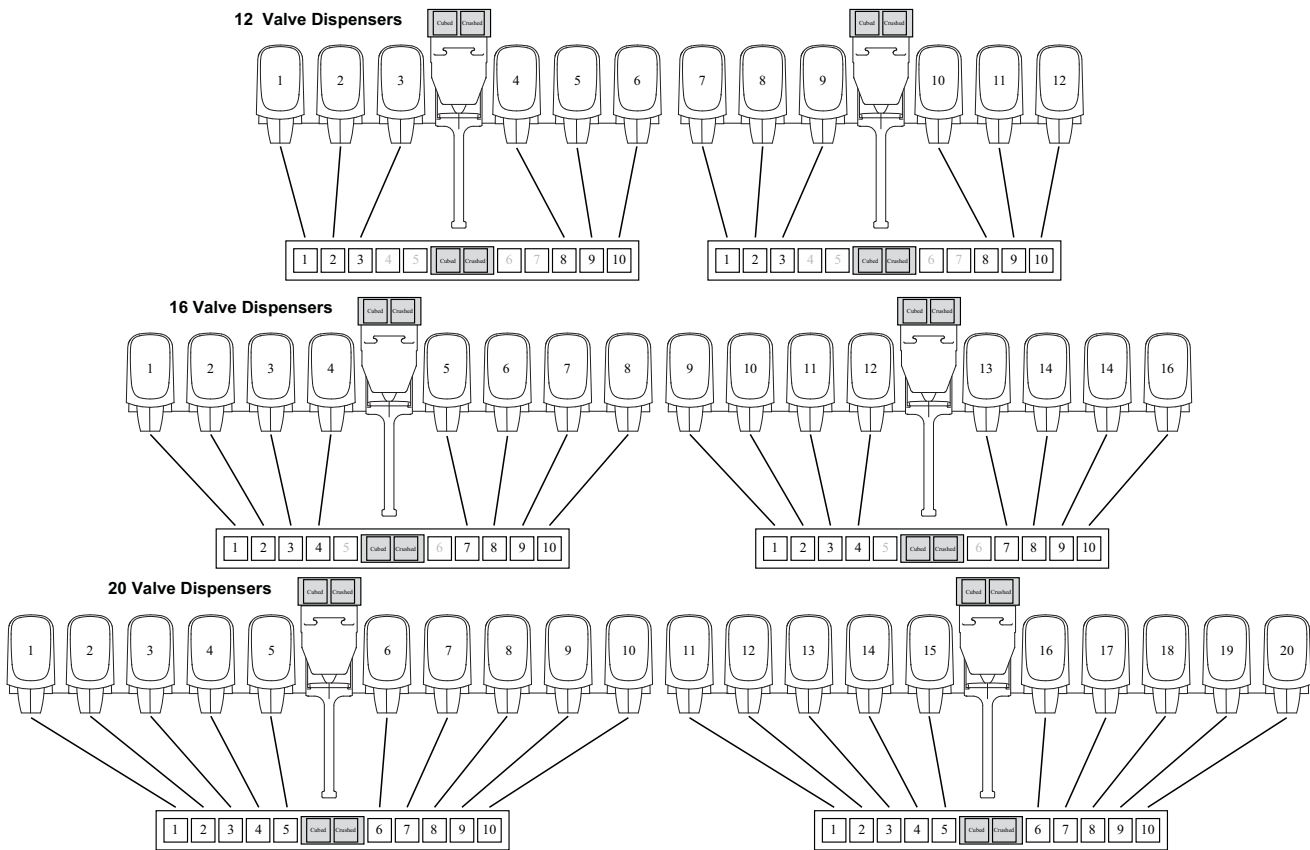

Finish Installation

- Put the splash panel and merchandiser back onto the unit and reinstall the screws that hold them in place.



NOTE: Restore power to the unit.

STARTING YOUR BEVERAGE SYSTEM & DISPENSER

Upon completion of the beverage dispenser and/or system installation, all tubing, dispenser and system components must be cleaned and sanitized prior to use.

NOTE: At installation, equipment, dispensers and tubing get moved through many environments, dirt, dust, chases, insulation, drywall, etc. It is an important procedure and best practice to address cleaning to deliver the best quality drink to your customer.

Important

Clean and sanitize the water and syrup circuits according to instructions provided in this manual. Clean and sanitize the dispenser components according to instructions provided in this manual. Seal to countertop when no legs are used with the unit. Consult and use local health codes if a discrepancy occurs between this manual and your local health codes.

Section 3 Operation

General System Overview

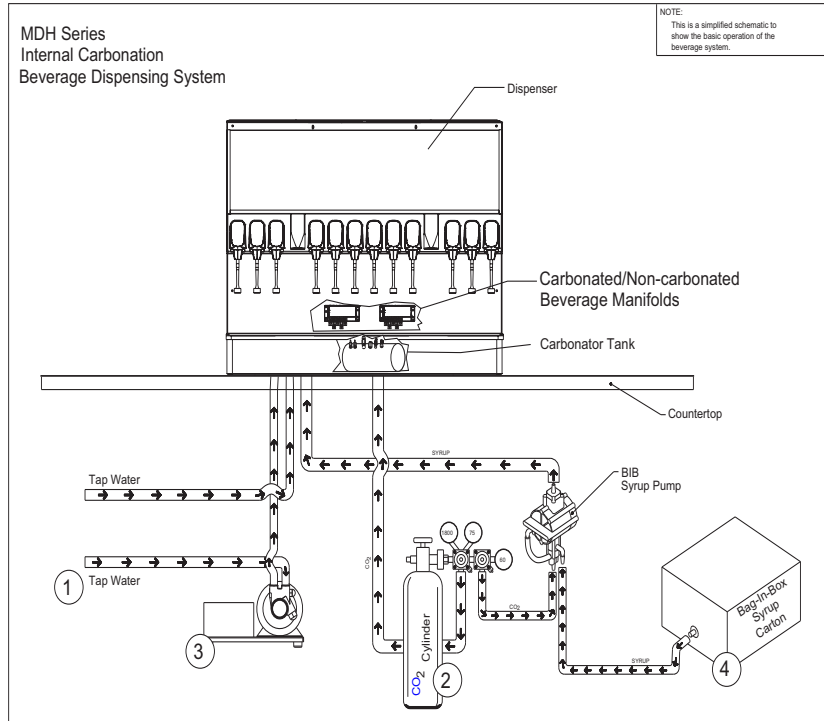

Typical Internal Carbonation Beverage Dispensing System

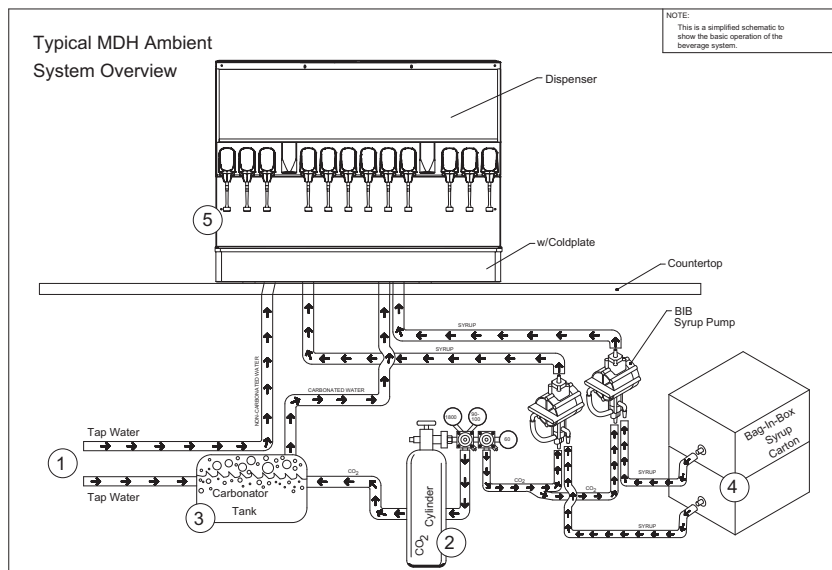

Typical External Carbonation (Ambient) Beverage Dispensing System

MDH-402 Cold Carbonation System

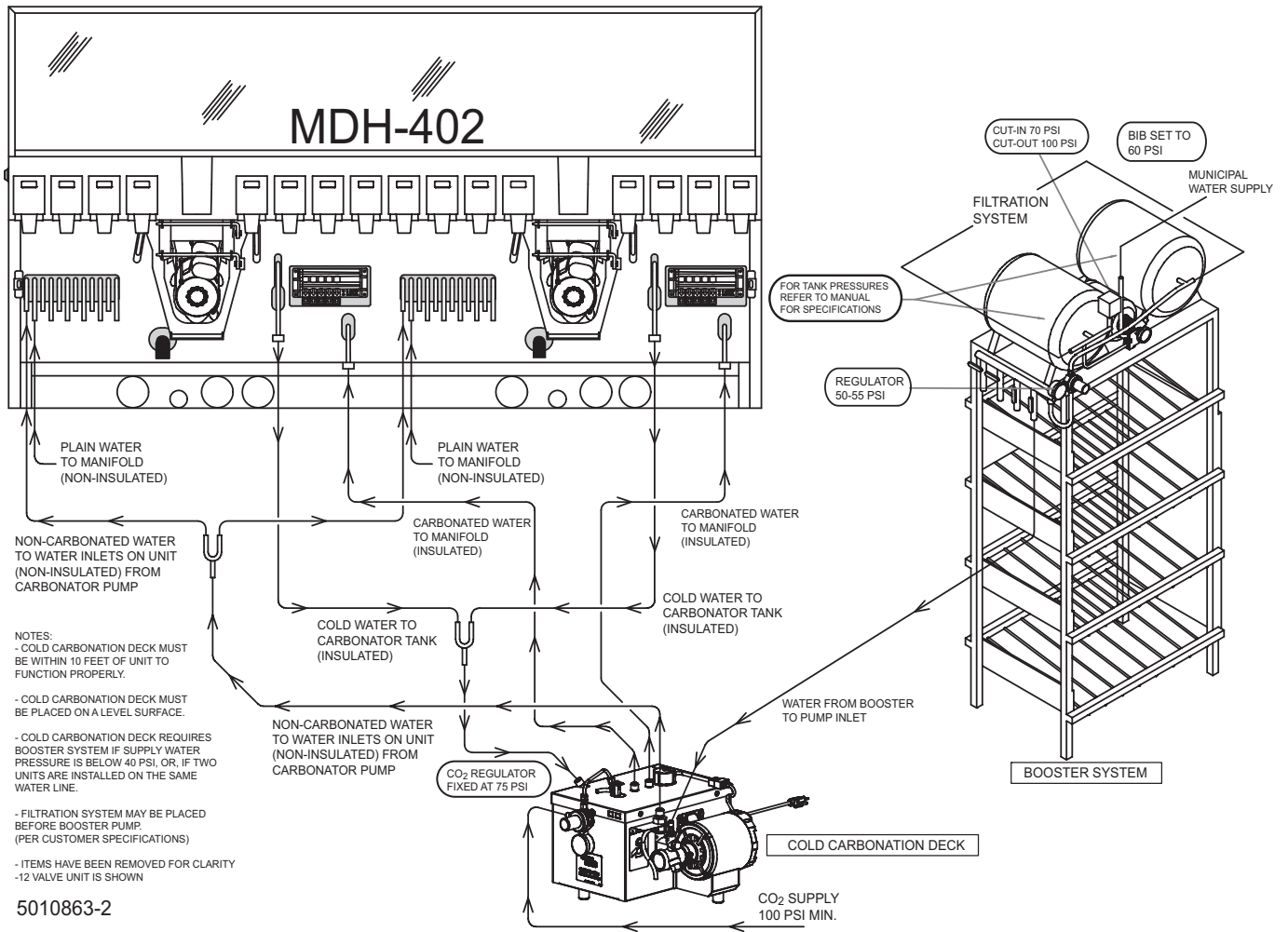

Typical MDH-402 Cold Carbonation Beverage Dispensing System

Component Identification

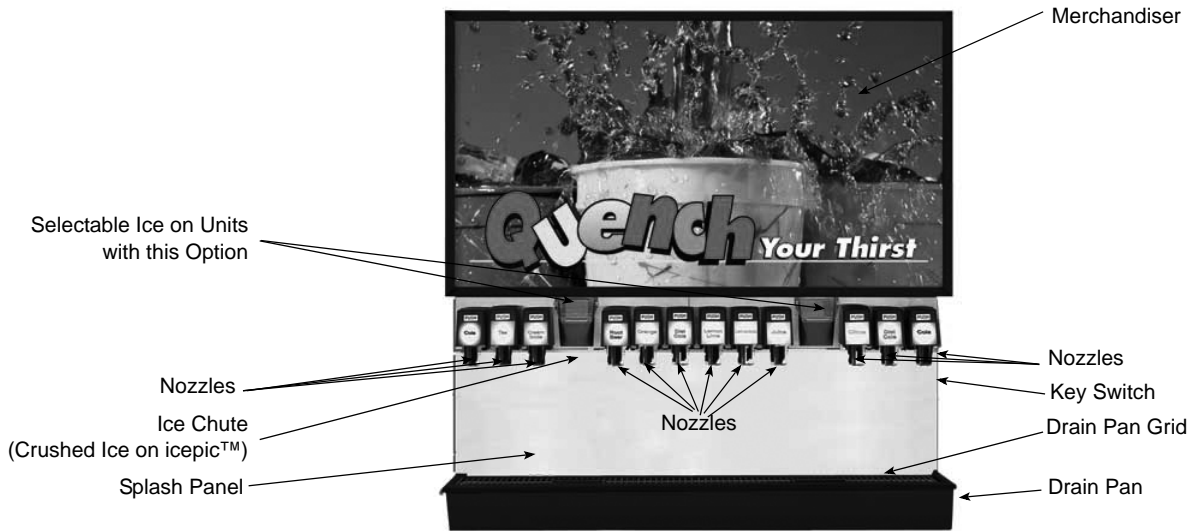

Sequence of Operation

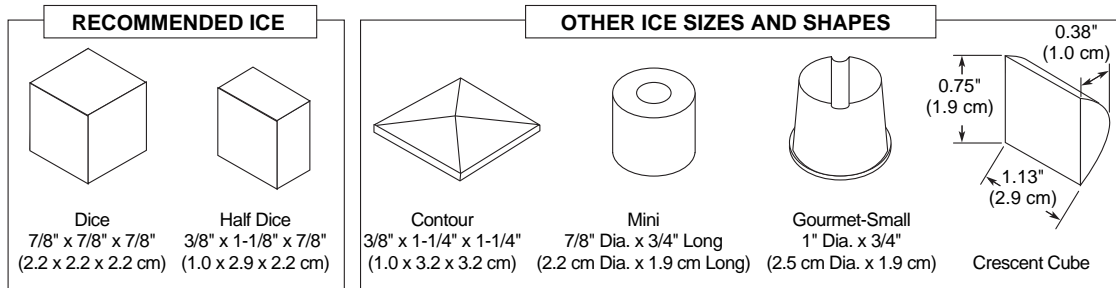

ICE RECOMMENDED FOR DISPENSING

Dispensers are designed to dispense hard, cube ice up to one-inch square. The ice shapes and sizes listed above are recommended for dispensing. Warm "Super Cooled" Ice Before Dispensing: "Super Cooled" ice is not recommended for dispensing. "Super Cooled" ice is ice that has been stored in freezers below 32°F. If it is necessary to temporarily use "Super Cooled" ice, allow the ice to warm at room temperature for 25 to 30 minutes before placing the ice in the dispenser.

NOTE: Manitowoc Half Dice Ice has been shown to give the best performance in the icepic™ dispenser. Hoshizaki America, Inc., ice machines with crescent-style shape cubes are compatible with this dispenser but not recommended.

NON-ADJUSTABLE AGITATION TIMER

The timer is non-adjustable and is set to agitate the ice for 3 seconds every 3.5 hours. Activating the dispenser will reset the timer. After 3.5 hours of non-use, the timer will energize the dispenser motor.

The LED tells the technician in which mode the timer is operating. Rather than a jumper pin, this timer has a female spade connector that must be connected to terminal number 6.

When this jumper is in place, the LED will blink at one second intervals, this is the run mode.

When the jumper is open, the LED will flash every 0.4 second. This is the test mode and the timer will cycle every 55 seconds in test mode. If the timer is left in test mode, it will automatically reset to run mode.

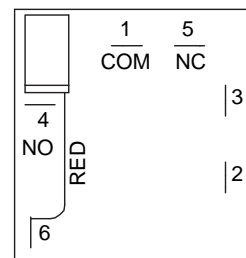

ICE STORAGE AND DISPENSING

As the customer presses the rocking chute, the arm at the top left rear of the chute pushes upward on the door lock. The door opens until it contacts the stops in the mounting brackets. The plastic arm on the ice chute also activates the lever of the ice dispensing switch. When activated, the micro switch starts the gear motor. The gear motor turns the paddle wheel and agitator arm.

The paddlewheel carries ice. Periodic agitation is standard on the 30" and larger dispensers. During periodic agitation, the paddle wheel and agitator turn for approximately three seconds every three and one half-hours. The door lock prevents ice from being dispensed during the agitation cycle.

Rocking Chute Ice Dispensing

As the customer presses the rocking chute, the arm at the top left rear of the chute pushes upward on the door lock. The door opens until it contacts the stops in the mounting brackets. The plastic arm on the ice chute also activates the lever of the ice dispensing switch. When activated, the micro switch starts the gear motor. The gear motor turns the paddle wheel and agitator bar.

Crushed Ice Dispensing

As a customer presses the ice chute the rocking chute door lifts and actuates micro switch which initiates the crushed ice dispensing process. When activated, the micro switch starts the gear motor and ice crusher motor. The gear motor turns the paddle wheel and U-bar agitator. The paddle wheel carries ice to the crusher assembly. Once the ice reaches the crusher housing, four stationary blades and three rotating blades crush the ice and push it through the opening in the ice crusher housing. The crushed ice then falls through the opening into the ice chute, and into the customer's cup.

Selectable Ice Sequence of Operation

As a customer presses the ice chute or pushes the sanitary lever towards the unit with their cup, with "crushed" selected on the ice selection pad, the rocking chute door lifts and actuates micro switch which initiates the crushed ice dispensing process. The micro switch is activated when the lever is approximately 1/4 inch from reaching the splash panel of the unit. When activated, the micro switch starts the gear motor and ice crusher motor. The gear motor turns the paddle wheel and U-bar agitator. The paddle wheel carries ice to the crusher assembly. Once the ice reaches the crusher housing, four stationary blades and three rotating blades crush the ice and push it through the opening in the ice crusher housing. The crushed ice then falls through the opening into the ice chute, and into the customer's cup. If the

merchandiser is removed, no power is available to the crusher or gear motor and no ice can be crushed and/or dispensed.

CARBONATION

The purpose of the carbonator is to take regular tap water at street water pressure (minimum 20 PSI, maximum 80 PSI, dynamic or flowing pressure), 1/2" water line and increase the water to beverage system pressure (usually 100 PSI). This water is then combined with the CO₂ gas. Because the water and gas are at the same pressure, the CO₂ will dissolve into the water. Chilling the mixture before dispensing will assist in locking the carbon dioxide into the water. After dispensing, the CO₂ may be unlocked from the liquid. The CO₂ will gradually leave the liquid due to pressure and temperature changes.

Components

The components of the carbonator are: water pump, an electric motor to operate the pump, carbonator tank where the water and CO₂ mix, and a water level control.

Operation

Carbon Dioxide (CO₂) leaves the storage tank and arrives at the carbonator tank through the gas inlet. Water supply enters the carbonator pump inlet at regular street water line pressure (minimum 20 PSI, maximum 80 PSI, dynamic or flowing pressure). The water pump increases the pressure of the water, which allows the water to flow into the carbonator tank. The CO₂ and the water mix together in the carbonator to produce the carbonated water that is then sent to the soda dispenser.

The agitation of the water and CO₂ together in the tank under high pressure creates the soda water. The quality of carbonation (percent of CO₂ mixed in the water) increases as the water temperature decreases and exposure time increases.

The water level in the carbonator tank is controlled by a water level control in the tank. This control turns the pump motor off and on to maintain a preset level of liquid in the tank. The water level control may be electronic probes or a mechanical float.

Syrup Delivery System

Your syrup location can vary depending on the volume of beverages served and ease of accessibility. Your beverage system may sit in a back storage room or under the counter of the dispenser. Configurations are almost limitless. Check the temperatures expected for

the storage location. Adverse temperatures can affect the storage and quality of beverage products. It is recommended the temperature of storage location should not fall below 40°F (4°C) or rise above 90°F (32°C).

Back Room Package

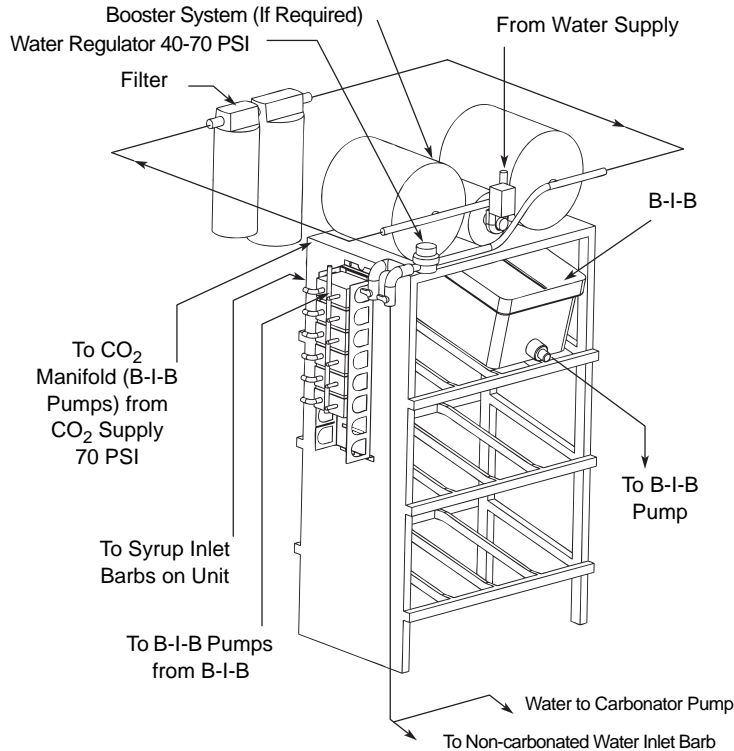

1. **Incoming tap water** - should be at a minimum dynamic pressure of 40 psi and maximum static pressure of 70 psi.
2. **Carbonator water pump motor** - Powers the water pump. The water pump motor is part of the carbonator pump deck.
3. **Carbonator water pump** - Pumps tap water into the carbonator tank. The water pump is part of the carbonator. The incoming water for the carbonator must be first run through the pump before connecting to the proper cold plate inlet.
4. **Internal/external carbonator tank** - Combines CO₂ gas and tap water to form carbonated water. The "carbonator" is the carbonator tank, water pump and water pump motor.
5. **CO₂ cylinder** - Holds highly pressurized carbon dioxide (CO₂). The CO₂ cylinder is a steel or aluminum cylinder tank. CO₂ gas flows through the primary pressure regulator.
6. **B-I-B pressure gauge** - Set for 75 psi. Indicates CO₂ pressure going to B-I-B pumps.
7. **Primary pressure regulator** - Lowers the CO₂ gas pressure, to 100 psi, so the CO₂ gas will be at the proper pressure to enter the carbonator regulator.
8. **Lowered outgoing pressure** - Set for 75 psi. Gauge indicates lowered outgoing pressure from the CO₂ cylinder after being routed through the primary pressure regulator at 100 psi.
9. **Secondary pressure regulator** - Lowers the CO₂ gas pressure before the CO₂ gas flows to the syrup pump. CO₂ pressure activates the syrup pump.
10. **Syrup pump** - Draws syrup out of the Bag-In-Box syrup package. Syrup flows through the syrup lines to the dispenser for chilling, then dispensing. There is a syrup pump for each Bag-In-Box syrup system.
11. **Bag-In-Box syrup cartons** - Box which contains a plastic bag, filled with syrup.

Racking

Regardless if you are working on a B-I-B or Figal system, a place will be designated for placement of the product. A rack (or shelf) system affords systematic placement and complete usage of the beverage paid for. The B-I-B rack allows the boxes to lay properly for syrup dispersal. Please check with your B-I-B syrup supplier. Some boxes must be slightly tilted down, while others may be in virtually any position. The Figal tank rack keeps the newer and full tanks organized at one end of the beverage line with the partial tanks at the other.

B-I-B

The Bag-In-Box system refers to a plastic disposable bag. The B-I-B normally contains 5 gallons of syrup, however some locations offer 2-1/2 gallon B-I-B units. This plastic bag is then held inside a cardboard or other container. B-I-B systems are for post-mix applications only.

Pumps

The syrup in a B-I-B system is delivered to the beverage system through gas operated pumps. These pumps extract the syrup out of the bags, forcing the syrup throughout the system.

Auto Bag Selectors

These are used on higher volume B-I-B systems where two or more bags of the same product are connected to one pump and one system. An auto bag selector is essentially a valve that automatically changes from one bag (or series of bags) to another bag (or series of bags) of syrup as the bags empty, allowing a constant flow of product.

FIGAL SYSTEM

Figal refers to the stainless steel tanks of pre-mix beverage or post-mix syrup. A small CO₂ tank pushes the beverage out of the figal tank.

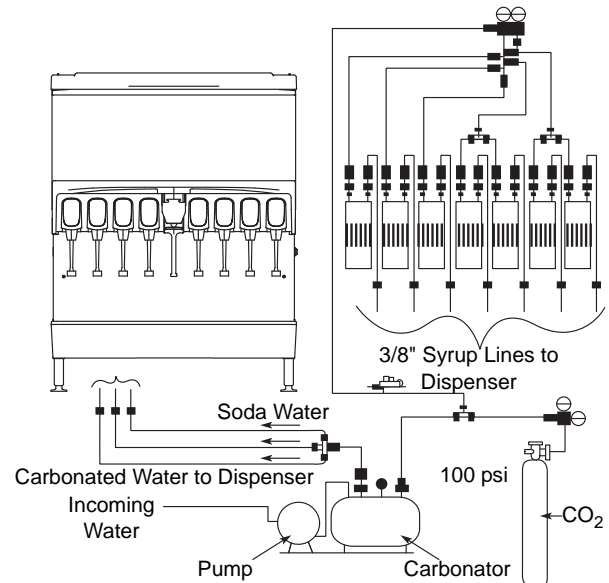

Tanks

The stainless steel Figal beverage tanks are easy to store and connect. When using the Figal tanks:

- Use a gas connector for the inlet fitting of the tank.
- Use a syrup connector for the outlet fitting of the tank.
- If more than one Figal tank is connected in series, when changing tanks, remove the tank closest to the original gas inlet while adding the new tank to the connector closest to the syrup outlet.

Most Figal tanks have a self-closing valve on the tank as well as the gas and syrup connectors. This allows the operator of the system to change tanks without having to shut down the entire system. With this type of connector, push down on the connector while pulling up on the **snap ring** around the opening of the connector. Then simply pull the connector off the tank.

Operation Checks & Adjustments

ICE DELIVERY SWITCH ADJUSTMENT

To properly adjust the switch, first unplug the power cord to the unit then remove the merchandiser. This will give you access to the ice delivery switch located on the left side of the rocking chute.

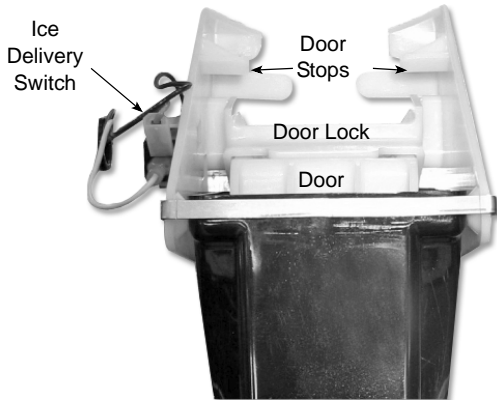

Begin by observing the chute while slowly pushing against the rocking chute. When the ice delivery switch clicks, measure the distance from the door stops on the rocking chute bracket to the door. The distance between the two must be no more than 1/4" (0.64 cm), but no less than 1/16" (0.16 cm).

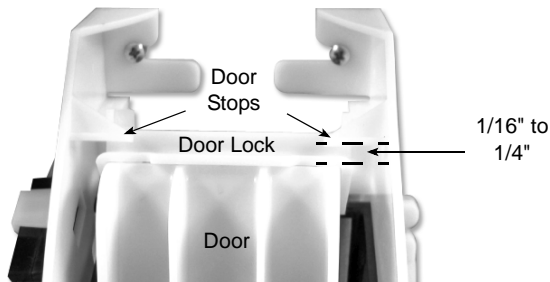

The left side of the rocking chute has a tab that pushes up on the ice delivery switch. To adjust it, use needle nose pliers and bend the arm of the switch up or down in order to change the point where the tab makes contact with the switch arm.

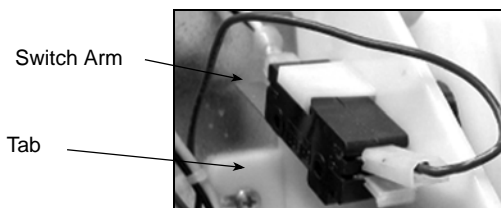

CRUSHED OR CUBED DEFAULT

For MDH Models equipped with Selectable Ice Modules, this selectable ice option will allow the unit to always default to either cube or crushed ice or remain at the last selection. This only applies to control boards [020000875](#) Rev 7 and up.

How to Set Cube Default

1. Power on the unit by plugging in receptacle and holding the CUBE button at the same time. CUBE will flash 2 times. Unit will now change to cube ice 10 seconds after CRUSHED is selected.

How to Set Crush Default

2. Power on the unit by plugging in receptacle and holding the CRUSHED button at the same time. CRUSHED will flash 2 times. Unit will now change to crushed ice 10 seconds after CUBE is selected.

How to Set Last Selection Default

3. Power on the unit by plugging in receptacle and holding CUBE and CRUSHED at the same time. CUBE and CRUSHED will flash 2 times. Unit will now remain in selection of last request.

NOTE: If power is lost to the unit and then powered up again the unit will retain the last setting and not return to factory settings.

AGITATION TIMER OPERATIONAL CHECK

For MDH Models equipped with Selectable Ice Modules there is a Selectable (CRUSHED and CUBE) ice agitation timer test mode:

1. Press and hold CUBE for over 1 second.
2. While holding CUBE, press CRUSHED three (3) times. All LEDs will flash indicating test mode.
3. While in the test mode, the agitator motor will cycle three (3) times, 3 seconds ON and 10 seconds OFF.
4. After the test mode is complete the unit will automatically reset to the run mode.

NOTE: To disable the test mode before the three (3) cycles are complete, press the CUBE button.

Section 4 Maintenance

Cleaning

DAILY CLEANING

All cleaning must meet your local health department regulations. The following cleaning instructions are provided as a guide.

⚠ Caution

Use only warm soapy water to clean the exterior of the tower. Do not use solvents or other cleaning agents. Do not pour hot coffee into the drain pan. Pouring hot coffee down the drain pan can eventually crack the drain pan, especially if the drain pan is cold or still contains ice.

⚠ Warning

Electric Shock Hazard

Unplug unit before servicing or cleaning.

⚠ Warning

When using cleaning fluids or chemicals, rubber gloves and eye protection must be worn.

Clean the exterior and drain pan:

1. Turn off the key switch located on either right or left side of the unit.
2. Lift the grid and remove it from the drain pan.
3. Using mild soap, warm water and a clean cloth, wipe the drain pan and splash panel. Then, rinse with clean, warm water. Allow plenty of warm (not hot) water to run down the drain of the drain pan, to remove syrup residue that can clog the drain opening.
4. Wash the grid, then rinse with clean water. Place the grid back in the drain pan.
5. Wash all exterior surfaces of the unit with warm water and a clean cloth. Wipe again with a clean, dry cloth.

Clean the dispensing valves:

6. Remove nozzles and diffusers from beverage valves.

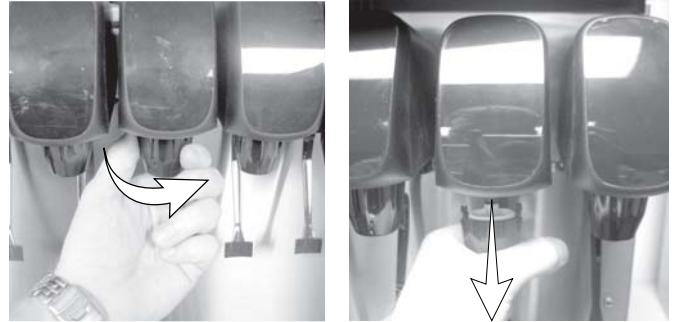

Nozzle Removal

7. Rinse nozzle and diffuser with warm, clean water.
8. Clean nozzles and diffusers with soapy water and a soft bristle brush.
9. Clean the underside of the beverage valves with warm, soapy water. Rinse with clean damp towel.
10. Replace nozzles and diffusers on valves.
11. Turn on the key switch.

MONTHLY CLEANING **Warning**

Unplug unit before servicing or cleaning ice bin.
Ice bin contains parts that can move at any time and will cause injury if hands are in the way.

 **Warning**

When using cleaning fluids or chemicals, rubber gloves and eye protection must be worn.

Clean and sanitize the ice bin:

1. Unplug unit and remove all ice from the ice bin.
2. Mix a solution of mild detergent to clean the dispenser bin and components.
3. Wash the ice bin using a sponge and the mild detergent solution.
4. Using the mild detergent solution and a soft bristle brush or clean cloth, clean the following dispenser parts:
 - Entire bin
 - Paddle wheel
 - Paddle wheel area
 - Agitator
 - Paddle wheel pin
 - Ice chute
 - Rear bushing
 - Motor shaft
 - Strip lids (where applicable)
5. Rinse all the parts in clean, running water.

6. Prepare 2 gallons of sanitizing solution by mixing 1/2 ounce of household bleach (that contains 5.25% sodium hypochlorite) with 2 gallons of 120°F (49°C) water. The mixture must not exceed 100 PPM of chlorine. Or mix a solution of any approved sanitizer, following the directions for mixing and applying the sanitizer.
7. Sanitize the ice bin and cold plate with the sanitizing solution for at least 10 seconds.
8. Allow to air dry. Do not rinse.

Re-assembling the dispenser parts:

9. Re-assemble parts in the following order:
 - Bin liner
 - Paddle wheel
 - Agitator
 - Paddle wheel pin
 - Ice chute
 - Merchandiser
10. Hand tighten all knurled fasteners.
11. Pour in fresh, sanitary ice and replace the plastic lid on the top of the dispenser.
12. Plug in the unit's electrical cord.
13. Check for proper ice dispensing.

CLEANING CHECKLIST

- Check CO₂ supply. If CO₂ supply is low, an arrow on the primary regulator gauge will point to a shaded area that reads "Low CO₂" or "Change CO₂ Cylinder."
- Check syrup supply.
- Clean drain pan, grid and splash panel.
- Clean the valve nozzles and diffusers.

Preventive Maintenance

Preventive maintenance is a vital part of keeping your dispenser in top condition. Following the guidelines below will assist you in continued trouble-free operation of your unit.

1. Conduct daily maintenance of the machine.
2. Perform monthly maintenance of the machine.
3. Perform periodic maintenance and sanitizing of beverage system.
4. Do not overfill the dispenser bin with ice.
5. Do not allow the dispenser to sit for prolonged periods of non-use with ice in the bin.
6. Most ice dispenser service problems are caused by low usage of the ice dispenser.
7. Do not allow ice to remain in the bin more than a day in order to prevent ice from freezing together and/or stagnant ice.

Possible excess ice storage reasons:

- Storage capacity exceeds daily requirements.
- Low demand during the off season.
- Dispenser oversized with future growth in mind.

Lower ice storage to meet one day's needs. If you manually fill ice, fill only with the appropriate amount of ice. Fill the dispenser with fresh ice each morning. Do not fill the dispenser at night just before shut down. Ice cubes can freeze together if not dispensed.

Disassembly

DISASSEMBLY FOR CLEANING AND MAINTENANCE

NOTE: Sanitize the ice dispenser at Initial Start-up in addition to monthly sanitizing. You will need a [slotted screwdriver](#) in order to disassemble.

Disassemble parts in the following order:

- A. Merchandiser
- B. Ice chute
- C. Paddle wheel or agitator pins
- D. Agitator
- E. Paddle wheel
- F. Bin liner
- G. Paddle wheel area

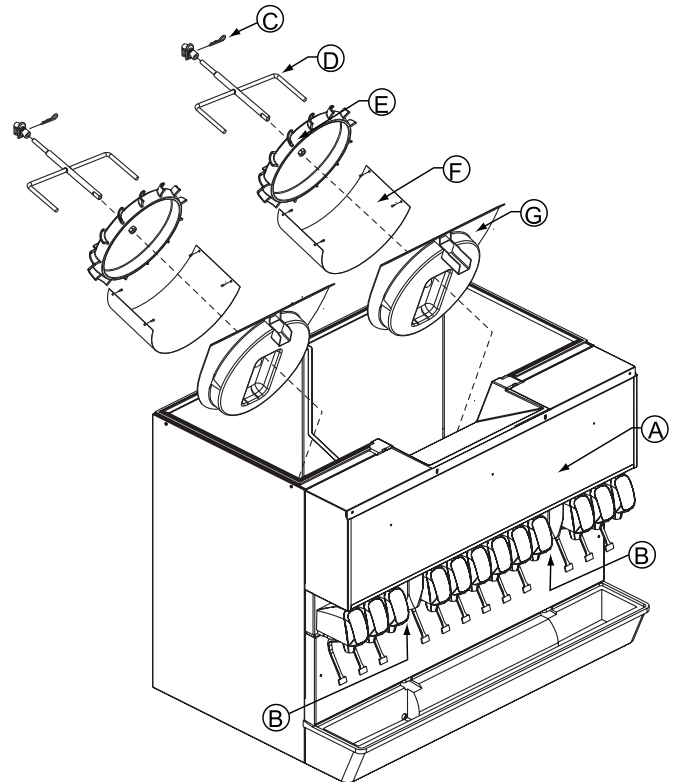

Beverage/Ice Dispenser

Accessing a Dispenser Bin that is Top Mounted with a Manitowoc Ice Machine:

1. Remove the front panel of the ice machine.
2. Remove the ice deflection baffle. This will give you access to the dispenser bin.
3. If the Manitowoc ice machine is operating, wait for the sheet of ice to fall into the dispenser bin.

Accessing a Dispenser Bin that is Top Mounted with a Manitowoc Ice Machine and Large Extended Merchandiser in front of the Ice Machine:

4. Access to the bin is possible through the strip lids on the side of the dispenser.

Disassembling the Dispenser Parts for Bin Cleaning:

5. Remove the front panel of the Manitowoc ice machine.
6. If the Manitowoc ice machine is operating, wait for the sheet of ice to fall into the dispenser bin. When the ice sheet falls into the dispenser bin, immediately place toggle switch of the ice machine to the OFF position. If the Manitowoc ice machine is NOT operating, place the toggle switch of the ice machine to the OFF position now.

7. On MDH models without a top mounted ice machine, remove the plastic lid from the top of the dispenser.
8. Remove all ice from the dispenser.
9. Disconnect electrical power to the dispenser.
10. Remove the strip lids off the top left and top right of the dispenser bin.
11. There is a left bin and a right bin on both the 302 and 402 models. Clean and sanitize one bin, then follow the same procedures on the second bin.

Non-front Serviceable Motor

- a. Rotate the agitator arm so the paddle wheel pin handle is pointing up, toward the ceiling.
- b. Prepare agitator pin for removal by removing the stainless steel split ring.
- c. Then remove the paddle wheel pin from the hole in the agitator.
- d. Push the agitator bar toward the back of the unit until the agitator is free of the paddle wheel hub.

Front Serviceable Motor

- a. With agitator arm in any position remove hitch clip pin from the mushroom bushing on the rear of the ice bin.
- b. Push the agitator bar toward the bushing to remove it from the paddle wheel hub.

NOTE: If a top mount ice machine is installed, sliding the ice machine to one side will make bin component removal easier. If the ice machine is hard plumbed, it will need to be disconnected.

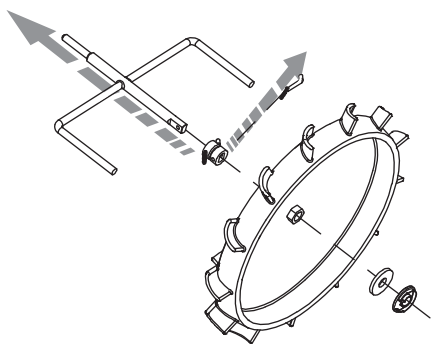

Non-front Serviceable

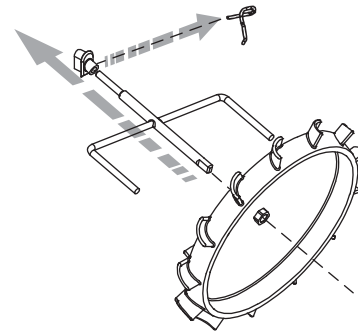

Front Serviceable

12. Remove paddle wheel, bin liner and paddle wheel area.
13. Move the front of the agitator to one side and slide the agitator forward until the rear of the agitator shaft is clear of the bushing.
14. Remove the agitator from the bin area.
15. Slide the paddle wheel from its shaft.
16. Loosen the four knurled fasteners that hold the bin liner in place.
17. Remove the bin liner.
18. Remove the paddle wheel area from the bin.
19. Discard the remaining ice in the bin.

DISASSEMBLE THE ROCKING CHUTE

1. Loosen the two knurled fasteners that hold the merchandiser in place.
2. Remove the merchandiser.
3. Remove outer bracket.
4. Remove door lock.
5. Remove door.
6. Remove ice chute.

DISASSEMBLE THE ICE CRUSHER ASSEMBLY

NOTE: These instructions cover icepic™ GENI, GENII, and Selectable Ice crushers.

1. Unplug unit before cleaning or servicing the crusher assembly.

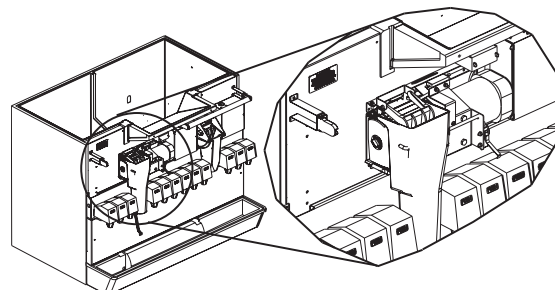

2. Remove the merchandiser. The merchandiser is removed by taking out the two (2) screws located at the top of the merchandiser. Once the screws are removed, lift and rotate the top of the merchandiser towards you and then remove the merchandiser from the unit.

NOTE: When the merchandiser is removed, an electrical safety switch kills power to the entire unit.

3. Remove rocking chute door.

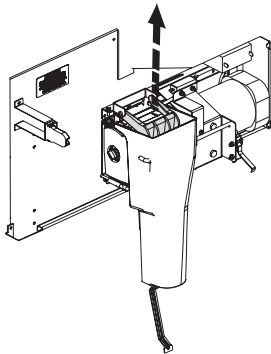

GENII ICEPIC™ ONLY

4. Remove the decorative ice chute by pulling the cotter pin out on the right side of the chute rod and pulling the chute rod toward the left side of the dispenser.

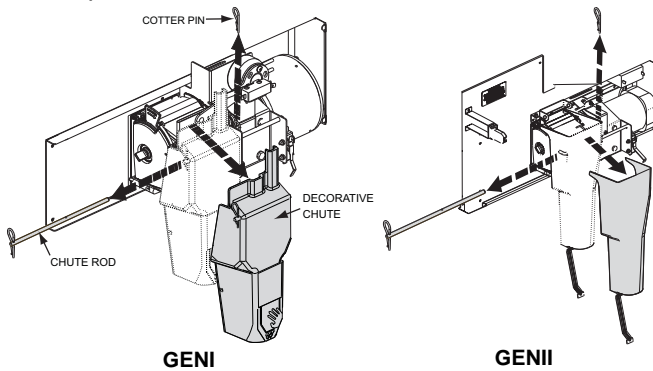

GENI

GENII

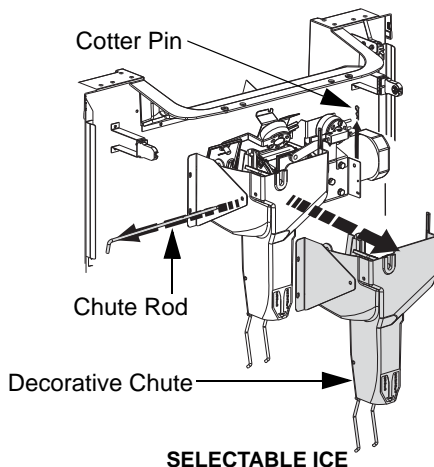

SELECTABLE ICE

5. Remove the crusher drip pan by pulling up slightly on the crusher assembly and pulling the drip pan away from the foam front.

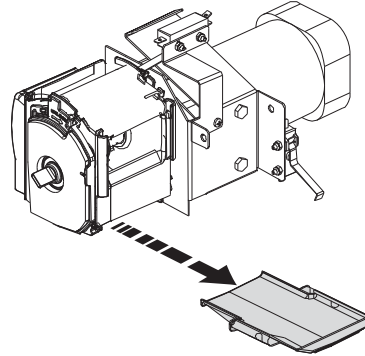

GENI, GENII & SCI drip pans are the same. GENII is illustrated on the left.

6. See the following steps to remove the ice crusher blade assembly from the crusher housing.
 - A. Unlock the crusher hub from the crusher housing by pulling the locking tab out and rotating the hub clockwise.
 - B. Pull the hub and blade assembly out of the housing approximately 1/2" (13 mm) to disengage the crusher axle from the motor shaft.

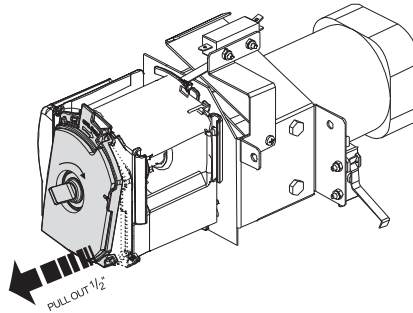

GENI, GENII & SCI blade assemblies are the same. GENII is illustrated on the left.

- C. Rotate the knob on the crusher axle so it is in a vertical position. (This will assure the rotating blades will not interfere with pulling the blade assembly from the housing.)

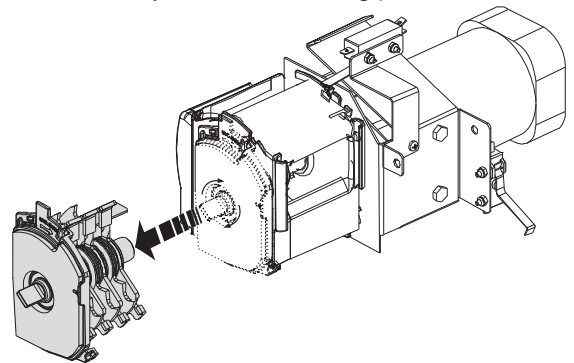

- D. Now the blade assembly will be free from the housing. Completely remove the blade assembly from unit.

MONTHLY ICE CRUSHER ASSEMBLY CLEANING

Once the ice crusher hub assembly has been removed, the crusher is ready to be cleaned and sanitized. Follow the steps below for proper cleaning and sanitizing procedures.

1. Assure the unit is unplugged.
2. Mix a solution of mild detergent to clean the ice crusher components.
3. Using the mild detergent solution and a soft bristle brush or clean cloth, clean the following ice crusher components.
 - Blade/hub assembly
 - Cosmetic chute
 - Drip pan
 - Crusher housing
 - Ice crusher motor shaft
 - Rocking chute door

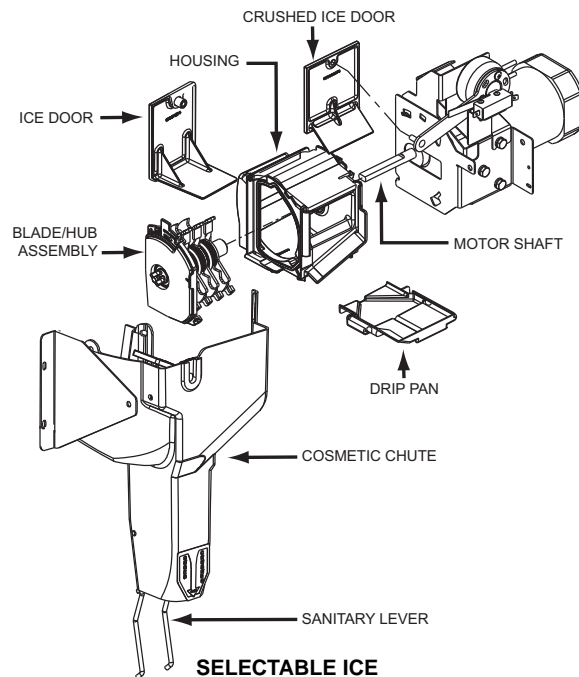
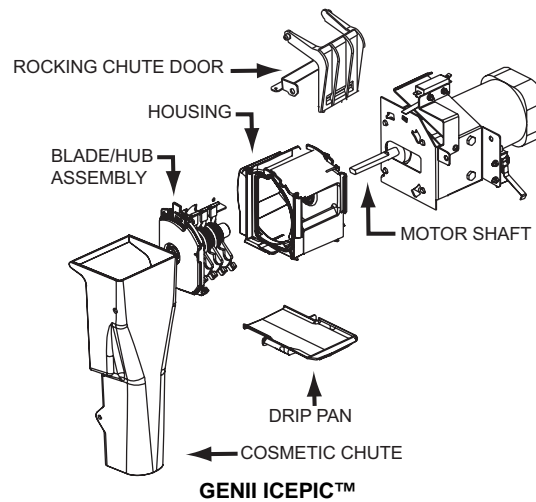
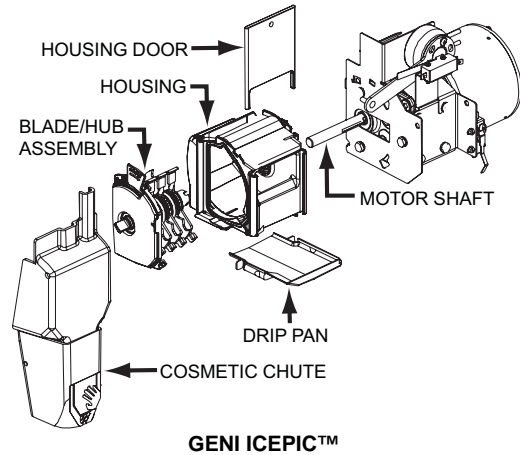

4. Rinse all of the parts with clean water.
5. Prepare 2 gallons of sanitizing solution by mixing a 1/2 ounce of household bleach (that contains 5.25% sodium hypochlorite) with 2 gallons of 120°F (49°C) water. The mixture should not exceed 100 PPM of chlorine. Or mix a solution of any approved sanitizer, following the directions for mixing and applying the sanitizer.
6. Apply sanitizer to all parts with clean cloth, or by spraying.
7. Allow to air dry. **DO NOT RINSE.**
8. Reassemble the ice crusher assembly by following the instructions in the "Reassembling the Ice Crusher Assembly" section.
9. Insert the blade assembly into crusher housing. When inserting blade assembly, align the stationary blades with the locating slots in the crusher housing.
10. When inserting the blade assembly into the crusher housing, make sure the axle knob is in a vertical position. This will align the rotating blades with the housing to assure a quick and easy installation.
11. Once all blades are in the housing, align the crusher axle with the motor shaft. Turn the axle knob and push the blade assembly toward the motor until the crusher hub is flush with the end of the housing.
12. To lock the blade assembly into the housing, rotate the crusher hub counterclockwise until the locking tab snaps into place and the crusher hub is secure.
13. Replace the crusher drip pan. Slide until it snaps into place.
14. Reattach the decorative ice chute by inserting the chute rod through the chute, housing mount and motor mount. Secure the chute rod by inserting cotter pin through the rod on the right side of the housing mount. Make sure the arm of the microswitch is in front of vertical protrusions on top of the decorative chute.
15. Reinstall the rocking chute door.
16. Reinstall the merchandiser and secure with the two screws that were removed during disassembly.
17. 110V power may be reapplied when the unit is completely reassembled.

REASSEMBLE THE ICE CRUSHER ASSEMBLY

1. Insert the blade assembly into the crusher housing. When inserting the blade assembly, align the stationary blades with the locating slots in the crusher housing.

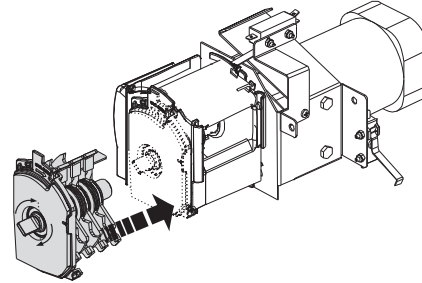

GENI, GENII & SCI blade assemblies are the same. GENII is illustrated on the left.

2. When inserting the blade assembly into the crusher housing, make sure the axle knob is in a vertical position. This will align the rotating blades with the housing to assure a quick and easy installation.
3. Once all blades are in the housing, align the crusher axle with the motor shaft. Turn the axle knob and push the blade assembly toward the motor until the crusher hub is flush with the end of the housing.
4. To lock the blade assembly into the housing, rotate the crusher hub counterclockwise until the locking tab snaps into place and the crusher hub is secure.

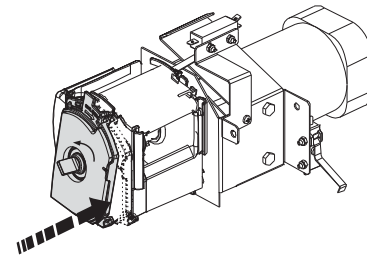

5. Replace the crusher drip pan, sliding it until it snaps into place by pulling up slightly on the crusher assembly and pushing the drip pan toward the foam front.

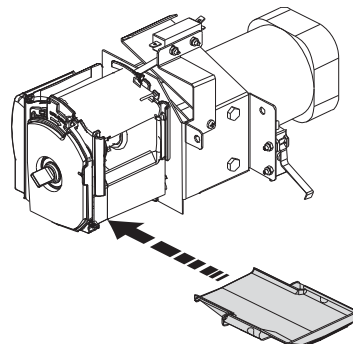

GENI, GENII & SCI drip pans are the same. GENII is illustrated on the left.

- Reattach the decorative ice chute by inserting the chute rod through the chute, housing mount and motor mount. Secure the chute rod by inserting cotter pin through the rod on the right side of the housing mount. Make sure the arm of the microswitch is in front of vertical protrusions on top of the decorative chute.

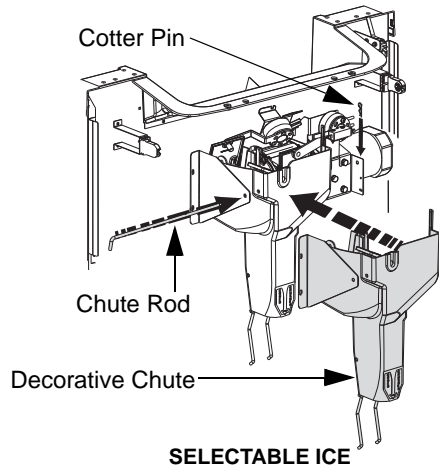
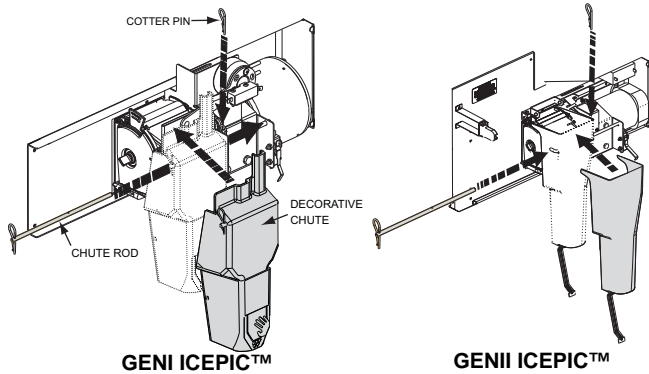

- Reinstall the rocking chute door.

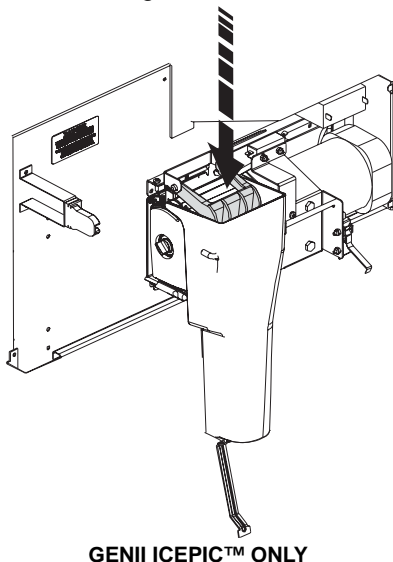

- Reinstall the merchandiser and secure with the two screws that were removed during disassembly.
- Power may be reapplied when the unit is completely reassembled.

GEAR MOTOR REMOVAL

These instructions are provided as a guide for the removal of the gear motor. Depending on the model number of your dispenser, these instructions may vary slightly.

NOTE: The drive train components changed to front serviceable units for the following model and serial numbers: MDH302 & MDH402 #610039642 & up.

Non-front Serviceable

- Disconnect power from the electric receptacle.
- Remove all ice from the ice storage bin of the dispenser.
- Remove the paddle wheel pin from the paddle wheel/agitator assembly inside the dispenser bin.
- Remove the agitator assembly from the dispenser bin by pushing the agitator to the back of the bin. Angle the front of the agitator to the side. Pull the agitator forward, then out of the dispenser.
- Remove the paddle wheel from the dispenser by pulling the hub of the paddle wheel to the back of the bin and off the gear motor shaft.
- Remove the splash panel from the dispenser and expose the gear motor.
- Disconnect the electric connector from the gear motor wire leads.
- Remove the pin in front of the gear motor.
- Remove the gear motor from the dispenser.
- To install a replacement gear motor, reverse this procedure.

Front Serviceable

These instructions are provided as a guide for the removal of the gear motor. Depending on the model number of your dispenser, these instructions may vary slightly.

1. Unplug the dispenser.
2. Unplug the motor.
3. Remove motor mount pins.



4. Slide motor towards you.
5. Notice alignment of the chamfered edge of drive shaft. The new motor must have the same alignment (within 15 degrees).



6. Get correct alignment one of two ways:
 - a. Turn drive shaft with an adjustable wrench, being careful not to damage the drive shaft.
 - b. Plug in the unit, plug in the motor and use the ice dispense switch to move the drive shaft into correct alignment.
7. If the unit was plugged in to help with alignment of drive shaft, now unplug the unit.
8. Slide motor up into housing, making sure that the tabs fit on the bracket.



9. Install motor mount pins.
10. Plug in motor.
11. Test unit.

Sanitizing

BEVERAGE SYSTEM CLEANING

Warning

Flush sanitizing solution from syrup system.
Residual sanitizing solution left in system could create a health hazard.

Warning

When using cleaning fluids or chemicals, rubber gloves and eye protection must be worn.

Sanitize the beverage system at initial start-up as well as regularly scheduled cleaning. The drain pan must be in place under soda valves, to carry away detergent and sanitizing agents that will be flushed through valves.

BAG-IN-BOX SYSTEM SANITATION

The procedure below is for the sanitation of one syrup circuit at a time. Repeat to sanitize additional circuits.

You will need the following items to clean and sanitize the Bag-in-Box (B-I-B) beverage system:

- Three (3) clean buckets
- Plastic brush or soft cloth
- Mild detergent
- Unscented bleach (5% Na CL O) or Commercial sanitizer
- Bag-In-Box bag connector

1. Prepare the following in the buckets:

- Bucket 1 — warm to hot tap water for rinsing.
- Bucket 2 — mild detergent and warm to hot water.
- Bucket 3 — mix a solution of unscented bleach (5% Na CL O) or commercial sanitizer and warm to hot water. Mixture must supply 100 PPM available chlorine (1/4 oz. bleach to 1 gallon water).

2. Disconnect the “syrup-line side” of the Bag-In-Box connector.



3. Rinse connector with warm tap water.

4. Connect syrup connector to B-I-B connector and immerse both into Bucket 1. A “bag-side” connector can be created by cutting the connector from an empty disposable syrup bag.

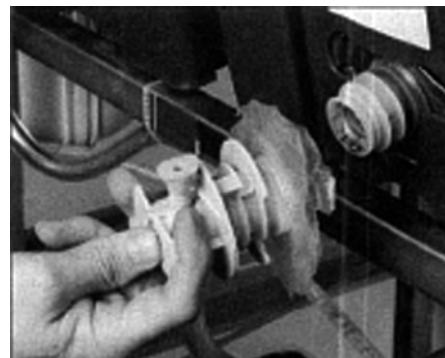
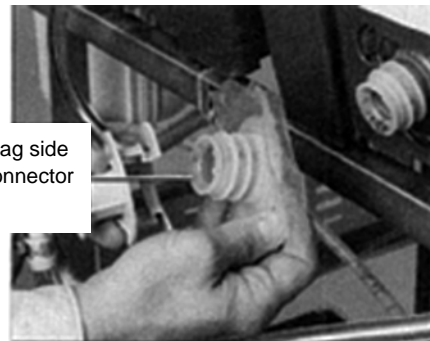

5. Draw rinse water through system until clean water is dispensed. Most beverage valves allow the syrup side to be manually activated by depressing the syrup pallet.
 6. Connect Bucket 2 to system.
 7. Draw detergent solution through system until solution is dispensed.
 8. Repeat steps 2-7 until all syrup circuits contain detergent solution.
 9. Allow detergent solution to remain in the system for 5 minutes.
 10. Connect Bucket 3 to system.
 11. Draw sanitizing solution through system until solution is dispensed.
 12. Repeat step 11 until all syrup circuits contain sanitizer solution.
 13. Allow sanitizer solution to remain in system for 15 minutes.
 14. Remove nozzles and diffusers from beverage valves.
 15. Scrub nozzles, diffusers and all removable valve parts (except electrical parts) with a plastic brush or a soft cloth and the detergent solution.
 16. Soak nozzles, diffusers and removable valve parts (except electrical parts) in sanitizer for 15 minutes.
 17. Replace nozzles, diffusers and valve parts.
 18. Connect Bucket 1 to system.
 19. Draw rinse water through system until no presence of sanitizer is detected.
 20. Attach syrup connectors to B-I-Bs.
 21. Draw syrup through system until only syrup is dispensed.
 22. Discard first 2 drinks.
2. Disconnect all product and water lines from product tanks and remove carbonator.
 3. Locate the Figal syrup tank for the circuit to be sanitized. Remove both quick disconnects from the Figal syrup tank. Rinse quick disconnects in tap water.
 4. Connect rinse tank to the syrup line. Draw clean rinse water through the valve until syrup is flushed from the system.
 5. Connect detergent tank to the syrup line and draw detergent through the valve for two minutes. Then, allow remaining detergent to stay in the system for five minutes.
 6. Connect rinse tank to the syrup line. Draw clean rinse water through the valve until detergent is flushed from the system.
 7. Remove valve nozzle and diffuser as shown in Daily Cleaning instructions. Using a plastic brush or a soft cloth and warm water, scrub the nozzle, diffuser, bottom of the dispensing valve and cup lever, if applicable.
 8. Place removable valve parts (EXCEPT solenoids) in sanitizing solution for 15 minutes.
 9. Replace valve diffuser and nozzle on the beverage valve.
 10. Connect sanitizer tank to the syrup line and draw sanitizer through the valve for two minutes. Allow sanitizer to remain in the system for a minimum of 15 minutes.
 11. Reconnect syrup and carbonated water lines.
 12. Draw syrup through the lines to rinse the system. Discard drinks until at least two cups of satisfactory tasting beverage are dispensed through the valve.

FIGAL BEVERAGE SYSTEM

1. Prepare the following in three clean Figal tanks:
 - **Rinse tank** - fill with room temperature tap water.
 - **Detergent tank** - mix approved beverage system cleaner with warm water as directed.
 - **Sanitizing tank** - mix a solution of unscented bleach (5% Na CL O) or commercial sanitizer and warm to hot water. Mixture must supply 100 PPM available chlorine (1/4 oz. bleach to 1 gallon water).

Shipping, Storage and Relocation

Caution

Before shipping, storing, or relocating this unit, syrup systems must be sanitized. After sanitizing, all liquids (sanitizing solution and water) must be purged from the unit. A freezing environment causes residual sanitizing solution or water remaining inside the unit to freeze, resulting in damage to internal components.

MDH Series Graphic Medallion Removal & Installation

The graphic medallions on the MDH Series Ice/Beverage Dispensers are made out of a flexible duratran that can be removed/replaced from the front of the unit without the use of tools (back-lit merchandiser light box does not need to be removed from the unit).

MEDALLION REMOVAL

1. Loosen and remove the 2 knurled screws from either the right or left side of the merchandiser frame starting with the bottom one first. Left side removal illustrated below. Note: A Phillips head screw driver may be used if the screws are too tight.
2. Remove the end portion of the frame that holds the medallion in the merchandiser.
3. With the end portion removed, pull the 2 clear plastic sheets apart inside the merchandiser to expose the medallion that is sandwiched in between.
4. Pull out only the medallion, leaving the 2 clear plastic sheets still inside the merchandiser.
5. To install/replace the medallion, slide the medallion back in between the 2 clear plastic sheets, replace the end portion of the frame and hand tighten the knurled screws.

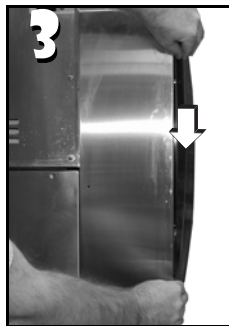
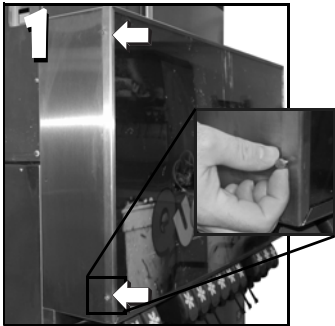

Section 5

Before Calling for Service

Checklist

If a problem arises during operation of your dispenser, follow the checklist below before calling service. Routine adjustments and maintenance procedures are not covered by the warranty.

Problem	Possible Cause	To Correct
Dispenser will not dispense ice (and NO SOUNDS are heard when machine is activated)	No power	Check electrical connection.
	Loose wire in electrical system	Thoroughly check all wire connections.
	Dispenser overloaded with ice	Remove ice from dispenser until unit will operate.
	Motor not working	Check thermally protected motor. Replace motor or capacitor if necessary.
Dispenser will not dispense ice (motor runs but no ice movement is heard in bin)	No ice in bin	Fill dispenser with ice.
	Door not opening	Check rocking chute mechanism or electric solenoid operation.
	Paddle wheel pin slipped from the paddle wheel	Replace paddle wheel pin.
Excessive clustering or bridging of ice	Loaded ice not broken up (Caution: Super cooled ice is not covered by the Servend warranty.)	Break ice clusters before manually filling the dispenser. (See ice recommendations.)
	Excessive water spilling from the ice machine	Adjust ice machine to eliminate water spillage.
	Poorly adjusted ice machine	Adjust ice machine to eliminate large waffle shapes.
	Extremely low usage of the dispenser	Lower the ice level in the bin.
Ice dispenses continuously	Misaligned microswitch	Adjust microswitch.
	Agitation timer set incorrectly	Test agitation timer.
Thumping noise or irregular sound at a particular area of the dispenser	Shaved ice clusters in the bin	Remove clusters, discover why ice is shaving, and then repair.
Dispensing crushed ice or reduced dispensing speed	Water spillage from ice machine into dispenser bin	Adjust ice machine.
	Agitation timer	Test agitation timer.
	Bridge of ice sheet is too thick	Adjust ice machine.
	Paddle wheel area broken or cracked	Replace paddle wheel area.
	Ice clusters in bin	Break up or remove clusters.
Door will not close	Door not fully open	Adjust door.
	Ice jammed in chute	Adjust bridge in ice machine or, when manually filling, break up clusters.
Door and/or door lock has come out of place		Replace door and lock into proper position.
Mounting brackets for rocking chute have spread too far apart		Bend parts into shape.

icepic™ Troubleshooting

Problem	Possible Cause	To Correct
DISPENSER DOES NOT DISPENSE CRUSHED ICE Nothing is heard	No power	Check power source and power cord.
	Loose wire in electrical system	Check wiring.
	Dispense switch faulty	Replace switch.
	Crusher motor faulty	Replace motor/gear box.
	Dispenser safety switch open	Assure merchandiser is installed correctly with the safety switch in the closed position.
Crusher motor hums but does not turn	Blades obstructed	Check for obstructions in ice crusher housing.
	Motor faulty	Replace motor.
	Faulty start relay/capacitor	Check relay/capacitor and replace if bad.
Crusher dispense door does not open	Door solenoid faulty	Replace solenoid.
	Loose wiring to solenoid	Check wiring.
Gear box on motor	Gear box on motor faulty	Replace ice crusher motor assembly.
	Crusher axle broken	Replace crusher axle.
Crusher motor turns but gear motor for paddle wheel/agitator bar does not turn	Agitator gear motor faulty	Replace agitator gear motor.
	Loose wiring	Check wiring.
	Obstruction in Ice bin stopping motor	Check for obstruction.
Nothing on dispenser works	No power to dispenser	Check power source.
	Dispenser safety switch open	Assure merchandiser is installed correctly with the safety switch in the closed position.
	Loose wiring	Check wiring.
Difficulty inserting blade/hub assembly into crusher housing	a. Stationary blades not aligned with locating slots at top and bottom of crusher housing	See "Disassemble the Ice Crusher Assembly" section in this manual.
	b. Rotating blades not in vertical position	
	c. Check for ice in crusher housing	
Crushed ice dispenses continuously, or by itself	Ice dispense switch faulty	Adjust bridge in ice machine or, when manually filling, break up clusters.
No flashing lights on keypad – Fluorescent light was on, crusher and whole ice dispenser will not function, transformer breaker blown	Water shorted out wiring harness on valves only	Clean up water and reset transformer.

Pump Troubleshooting

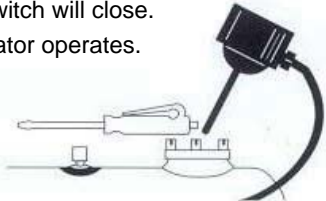
Problem	Possible Cause	Corrective Action
Pump motor does not shut off	Problem with probe or probe harness	<ol style="list-style-type: none"> 1. Remove probe electronics. 2. Pass magnetic tip of screwdriver by lower end of tube extending from electronics package. 3. Reed switch will close. 4. Carbonator operates. 
Pump motor intermittent	Problem with probe or probe harness	
Pump motor does not pump	Water pressure from water source is not high enough	Verify water pressure leading into pump inlet is 40 psi minimum.

Selectable Ice Troubleshooting

Problem	Possible Cause	To Correct
DISPENSER DOES NOT DISPENSE CRUSHED ICE Nothing is heard	No power	Check power source and power cord.
	Loose wire in electrical system	Check wiring.
	Dispense switch faulty	Replace switch.
	Crusher motor faulty	Replace motor/gear box.
	Dispenser safety switch open	Assure merchandiser is installed correctly with the safety switch in the closed position.
Crusher motor hums but does not turn	Blades obstructed	Check for obstructions in ice crusher housing.
	Motor faulty	Replace motor.
	Faulty start relay/capacitor	Check relay/capacitor and replace if bad.
Crusher dispense door does not open	Door solenoid faulty	Replace solenoid.
	Loose wiring to solenoid	Check wiring.
Gear box on motor	Gear box on motor faulty	Replace ice crusher motor assembly.
	Crusher axle broken	Replace crusher axle.
Crusher motor turns but gear motor for paddle wheel/agitator bar does not turn	Agitator gear motor faulty	Replace agitator gear motor.
	Loose wiring	Check wiring.
	Obstruction in Ice bin stopping motor	Check for obstruction.
Nothing on dispenser works	No power to dispenser	Check power source.
	Dispenser safety switch opens	Assure merchandiser is installed correctly with the safety switch in the closed position.
	Loose wiring	Check wiring.
Difficulty inserting blade/hub assembly into crusher housing	a. Stationary blades not aligned with locating slots at top and bottom of crusher housing	See "Disassemble the Ice Crusher Assembly" section in this manual.
	b. Rotating blades not in vertical position	
	c. Check for ice in crusher housing	
Crushed ice dispenses continuously, or by itself	Ice dispense switch faulty	Adjust bridge in ice machine or, when manually filling, break up clusters.
No flashing lights on keypad – Fluorescent light was on, crusher and whole ice dispenser will not function, transformer breaker blown	Water shorted out wiring harness on valves only	Clean up water and reset transformer.

Drink Troubleshooting

Condition	Investigation	Check	Correction
Water only dispensing	No pressure	Regulator(s) out of adjustment	Check/adjust regulator(s).
		Out of CO ₂	Install fresh tank.
		Defective regulator(s)	Check/repair/replace regulator(s).
		CO ₂ line pinched, kinked or obstructed	Check/repair/replace CO ₂ line.
Syrup and CO ₂ only dispensing	Carbonator	No power	Check power supply. Plug in carbonator or reset breaker.
		Water supply	Make sure water is turned "on".
			Replace water filter.
			Check/clean/replace pump strainer.
			Check/clean/repair water check valve.
Defective carbonator	Check for frozen water line. Internal carbonator unit only. Check/repair/replace carbonator pump, motor, electrode or liquid level control.		
Syrup and plain water only dispensing	No pressure	Out of CO ₂	Install fresh tank.
		HP regulator out of adjustment	Adjust HP regulator to the proper setting.
		Defective HP regulator	Check/repair/replace HP regulator.
		CO ₂ line pinched, kinked or obstructed	Check/repair/replace CO ₂ line.
One valve will not dispense anything	Is there power to the valve?	Broken wire or loose connection	Replace/repair wire or connector.
		Bad microswitch	Replace microswitch.
Beverage dispensed is too sweet	Is the ratio (brix) of the drink correct?	Flow control out of adjustment	Adjust the flow control.
		Insufficient soda flow due to low carbonator pressure	Adjust CO ₂ pressure or change the tank.
		Low CO ₂ pressure due to leaks	Repair CO ₂ leaks.
		Obstruction in the water or soda line	Clean out the lines.
Beverage is not sweet enough	Is the ratio (brix) of the drink correct?	Flow control out of adjustment	Adjust the flow control.
		Soda flow too high	Reset CO ₂ pressure or replace regulator if necessary.
		Obstruction in syrup line	Clean out the syrup line.
Drinks are foaming	Are system pressures correct?	Over carbonation	Check CO ₂ supply. Reset pressure or replace regulator if necessary.
		Dirty lines/valves	Clean/sanitize entire system.
No water, syrup or gas dispensing	Is there power to the unit?	No power	Plug in unit or reset breaker.
		Power to control box	Replace fuse or control box.
	Is power coming through the key switch?	Key switch "off"	Turn switch "on".
		Key switch defective	Replace key switch.
	Is there power to the key switch?	No power through the transformer	Reset/replace transformer.

Liquid Level Control Troubleshooting

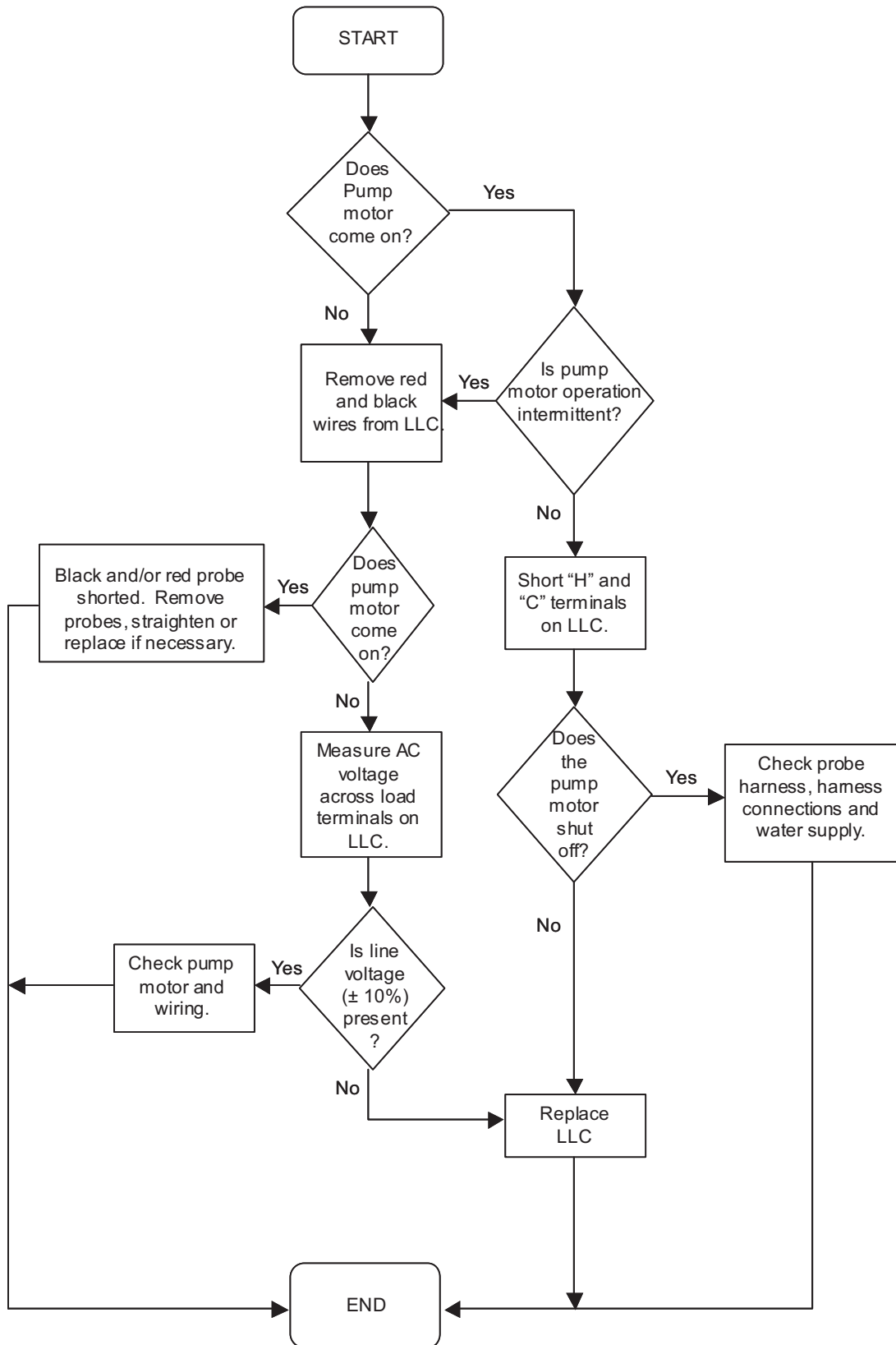

THIS PAGE INTENTIONALLY LEFT BLANK

Continuing product
improvements may necessitate
change of specifications without
notice.

Part Number 020003999 8/15



Multiplex
645 Park East Blvd, Suite 5
New Albany, IN 47150, USA
Ph: 844-724-2273 Fax: 812-246-7020
Visit us online at:
www.multiplexbeverage.com