

MII SERIES

150/200/250/302 & 402 Ice Dispensers



Servend®

INSTALLATION & SERVICE GUIDE

Part Number 5028935



Manitowoc Beverage Equipment

2100 Future Drive w Sellersburg, IN 47172-1868
Tel: 812.246.7000, 800.367.4233 • Fax: 812.246.9922
www.manitowocbeverage.com

In accordance with our policy of continuous product development and improvement, this information is subject to change at any time without notice.

October 19, 2006 REV3



FOREWORD

Manitowoc Beverage Equipment (MBE) developed this manual as a reference guide for the owner/operator, service agent, and installer of this equipment. Please read this manual before installation or operation of the machine. A qualified service technician should perform installation and start-up of this equipment, consult the *Troubleshooting Guide* within this manual for service assistance.

If you cannot correct the service problem, call your MBE Service Agent or Distributor. Always have your model and serial number available when you call.

Your Service Agent _____

Service Agent Telephone Number _____

Your Local MBE Distributor _____

Distributor Telephone Number _____

Model Number _____

Serial Number _____

Installation Date _____

UNPACKING AND INSPECTION

Note: The unit was thoroughly inspected before leaving the factory. Any damage or irregularities should be noted at the time of delivery.

WARRANTY INFORMATION

Consult your local MBE Distributor for terms and conditions of your warranty. Your warranty specifically excludes all beverage valve brixing, general adjustments, cleaning, accessories and related servicing.

Your warranty card must be returned to Manitowoc Beverage Equipment to activate the warranty on this equipment. If a warranty card is not returned, the warranty period can begin when the equipment leaves the MBE factory.

No equipment may be returned to Manitowoc Beverage Equipment without a written Return Merchandise Authorization (RMA). Equipment returned without an RMA will be refused at MBE's dock and returned to the sender at the sender's expense.

Please contact your local MBE distributor for return procedures.

TABLE OF CONTENTS

FOREWORD	3
UNPACKING AND INSPECTION	3
WARRANTY INFORMATION	3
SAFETY	6
IMPORTANT SAFETY INSTRUCTIONS	6
CARBON DIOXIDE WARNING	6
QUALIFIED SERVICE PERSONNEL	6
SHIPPING, STORAGE, AND RELOCATION	6
ADDITIONAL WARNINGS	6
GROUNDING IN STRUCTIONS	7
INSTALLATION	8
PRE-INSTALLATION CHECK LIST	8
INSTALLATION CHECK LIST	8
DRAINAGE OPTIONS	8
TOP MOUNTED ICEMAKER REQUIREMENTS	9
ICE FLOW RESTRICTOR	9
ROCKING CHUTE ICE DELIVERY SWITCH ADJUSTMENT	10
BAFFLE FOR MANITOWOC™ CUBERS	11
BAFFLE FOR "Q" SERIES ICE MACHINES	11
MANUAL FILL LID FOR DISPENSERS WITH A CUBER	11
GENERAL INSTRUCTIONS FOR REMOVAL OF GEAR MOTOR	12
OPERATION	13
UNIT INSPECTION	13
ICE RECOMENDED FOR DISPENSING	13
ICE STORAGE AND DISPENSING	13
BEVERAGE VALVES	13
LEGS	13
115V/220V NON ADJUSTABLE AGITATION TIMER	13
MII MEASUREMENTS & SPECIFICATIONS	14
MII-302 MEASUREMENTS & SPECIFICATIONS	15
MII-402 MEASUREMENTS & SPECIFICATIONS	16
MII-250 FOOTPRINT	18
MII-302 FOOTPRINT	19

TABLE OF CONTENTS

USER MAINTENANCE	20
SANITIZING AND CLEANING	20
DAILY CLEANING	20
CLEANING AND SANITIZING THE DISPENSER	20
RE-ASSEMBLING THE DISPENSER PARTS	20
PREVENTATIVE MAINTENANCE	21
HOW TO DISASSEMBLE FOR CLEANING OR MAINTENANCE	21
DAILY CLEANING	24
MONTHLY CLEANING	25
EXPLODED VIEWS, PARTS & DIAGRAMS	26
MII-150, 175, 200, & 250	26
MII-150 PARTS LIST	27
MII-175 PARTS LIST	27
MII-200/250 PARTS LIST	28
MII - 302	29
MII-302 PARTS LIST	30
MII-150/175/200/250 115V WIRING	31
MII-302 115V WIRING	32
TROUBLESHOOTING	34
INDEX	39

SAFETY

IMPORTANT SAFETY INSTRUCTIONS

Carefully read all safety messages in this manual. Learn how to operate the MII unit properly. Do not allow anyone to operate the unit without proper training and keep it in proper working condition. Unauthorized modifications to the MII may impair function and/or safety and affect the life of the unit.

CARBON DIOXIDE WARNING



DANGER: Carbon Dioxide (CO₂) displaces oxygen. Exposure to a high concentration of CO₂ gas causes tremors, which are followed rapidly by loss of consciousness and suffocation. If a CO₂ gas leak is suspected, particularly in a small area, immediately ventilate the area before repairing the leak. CO₂ lines and pumps should not be installed in an enclosed space. An enclosed space can be a cooler or small room or closet. This may include convenience stores with glass door self serve coolers. If you suspect CO₂ may build up in an area, venting of the B-I-B pumps and / or CO₂ monitors should be utilized.

QUALIFIED SERVICE PERSONNEL



WARNING: Only trained and certified electrical and plumbing technicians should service this unit. All wiring and plumbing must conform to national and local codes.

SHIPPING, STORAGE, AND RELOCATION



CAUTION: Before shipping, storing, or relocating this unit, syrup systems must be sanitized. After sanitizing, all liquids (sanitizing solution and water) must be purged from the unit. A freezing environment causes residual sanitizing solution or water remaining inside the unit to freeze, resulting in damage to internal components.

ADDITIONAL WARNINGS

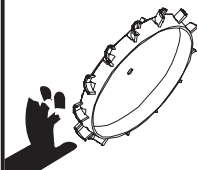
	<p>CAUTION</p> <p>Unplug unit before servicing or cleaning ice bin.</p> <p>Ice bin contains parts that can move at any time and will cause injury if hands are in the way.</p>
---	---

<p>WARNING</p> <p>Flush sanitizing solution from syrup system</p> <p>Residual sanitizing solution left in system could create a health hazard</p>
--

	<p>WARNING</p> <p>When using cleaning fluids or chemicals, rubber gloves and eye protection should be worn</p>
--	---

	<p>WARNING</p> <p>UNPLUG UNIT BEFORE SERVICING OR CLEANING</p> <p>ELECTRIC SHOCK HAZARD</p>
--	---

Installation and start-up of this equipment should be done by a qualified service technician. Operation, maintenance, and cleaning information in this manual are provided for the user/operator of the equipment. **Save these instructions.**

SAFETY

GROUNDING INSTRUCTIONS



WARNING: Risk of electrical shock. Connect to a properly grounded outlet only.

This appliance must be grounded. In the event of malfunction or breakdown, grounding provides a path of least resistance for electric current to reduce the risk of electric shock. This appliance is equipped with a cord having an equipment-grounding conductor and a grounding plug. The plug must be plugged into an appropriate outlet that is properly installed and grounded in accordance with all local codes and ordinances.

DANGER – Improper connection of the equipment-grounding conductor can result in a risk of electric shock. The conductor with insulation having an outer surface that is green with or without yellow stripes is the equipment grounding conductor. If repair or replacement of the cord or plug is necessary, do not connect the equipment-grounding conductor to a live terminal. Check with a qualified electrician or serviceman if the grounding instructions are not completely understood, or if in doubt as to whether the appliance is properly grounded. Do not modify the plug provided with the appliance – if it will not fit the outlet, have a proper outlet installed by a qualified electrician.

WARNING – When using electric appliances, basic precautions should always be followed, including the following:

- a) Read all the instructions before using the appliance.
- b) To reduce the risk of injury, close supervision is necessary when an appliance is used near children.
- c) Do not contact moving parts.
- d) Only use attachments recommended or sold by the manufacturer.
- e) Do not use outdoors.
- f) For a cord-connected appliance, the following shall be included:
 - Do not unplug by pulling on cord. To unplug, grasp the plug, not the cord.
 - Unplug from outlet when not in use and before servicing or cleaning.
 - Do not operate any appliance with a damaged cord or plug, or after the appliance malfunctions or is dropped or damaged in any manner. Return appliance to the nearest authorized service facility for examination, repair, or electrical or mechanical adjustment.
- g) For a permanently connected appliance – Turn the power switch to the off position when the appliance is not in use and before servicing or cleaning.
- h) For an appliance with a replaceable lamp – always unplug before replacing the lamp. Replace the bulb with the same type.
- i) For a grounded appliance – Connect to a properly grounded outlet only. See Grounding Instructions.

SAVE THESE INSTRUCTIONS

INSTALLATION

PRE-INSTALLATION CHECK LIST

- | | |
|--|---|
| <ol style="list-style-type: none"> 1 Do you have enough space to install the dispenser or a dispenser and top mounted cuber? 2 Does the top mounted cuber (if utilized) have a minimum of 6 inches (15.3) cm clearance on all sides? | <ol style="list-style-type: none"> 3 Is the countertop level? 4 Can the countertop support the weight of the dispenser, or the dispenser/cuber combination plus the weight of the stored ice? |
|--|---|

INSTALLATION CHECK LIST

- | | |
|--|--|
| <ol style="list-style-type: none"> 1 Place the dispenser in the desired location. 2 Install drain plumbing and insulate. 3 Fill bin with ice. | <ol style="list-style-type: none"> 4 Connect power supply. 5 Meet all code requirements. 6 Dispense a few cups of ice to check for proper operation |
|--|--|

DRAINAGE OPTIONS

The drains for MII Series connects to the drain pan.

Drainage Option One

Drainage through the bottom of the unit.

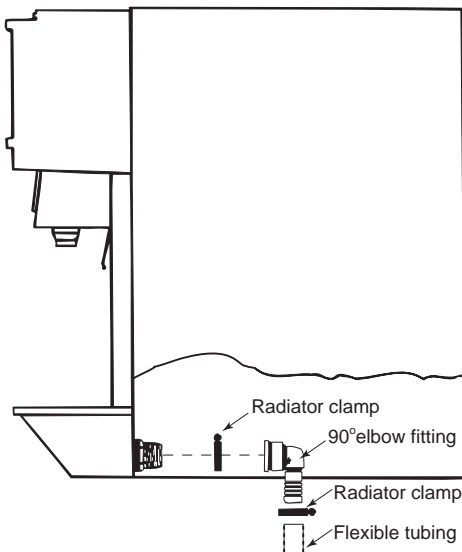

Drainage Option Number Two

Drainage through the back of the unit.

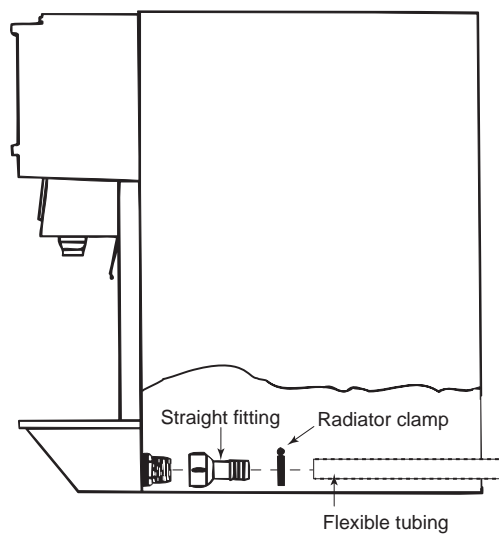

**MII 302 AND 402 WILL HAVE
TWO DRAINS**

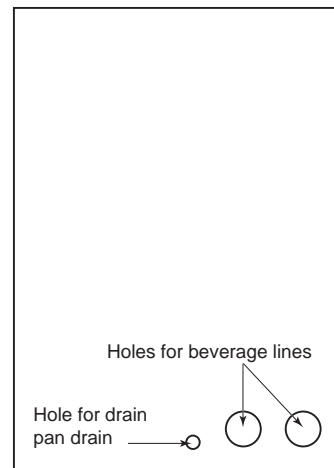

INSTALLATION

TOP MOUNTED ICEMAKER REQUIREMENTS

- 1 Location** - Avoid placing the dispenser and/or ice machine near heat sources such as radiators, ovens, refrigeration equipment and direct sunlight.
- 2 Clearances** - Six inch (15.2 cm) clearance on all sides of the icemaker is needed.
- 3 Front of icemaker to be flush with front of dispenser**- The front of the icemaker should be flush with the front of the dispenser, as shown in the drawing above. Because the icemaker is flush with the

front of the dispenser, some icemakers may overhang at the back of the dispenser.

- 4 Drains** - A separate drain line is required for the ice machine, in addition to a drain line for the ice/beverage dispenser.
- 5 MII Series dispensers require an adapter kit to install some top-mounted icemakers.** Contact your local Multiplex distributor for the correct adapter kit.

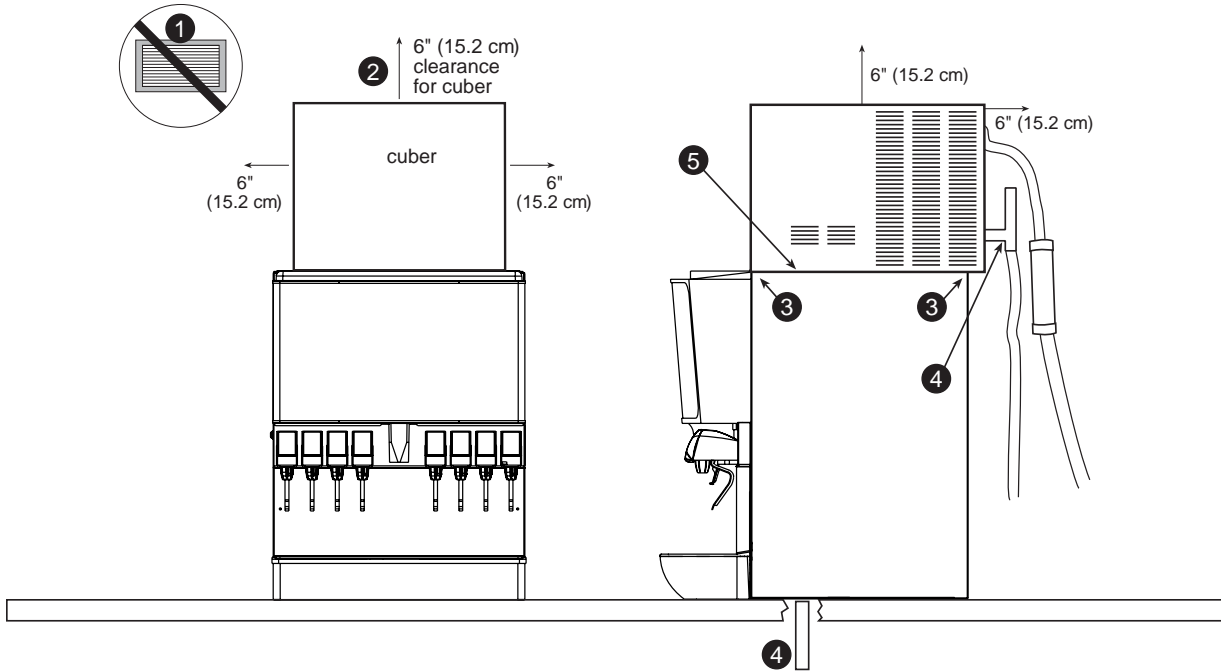

NOTE: For full information about icemaker installation, including plumbing lines connections and electrical requirements, see the icemaker installation manual.

ICE FLOW RESTRICTOR



Ice Flow Restrictor

For all MII, MD and MDH Series dispensers an Ice flow restrictor is available. This ice flow restrictor decreases the amount of ice allowed to enter the ice chute by blocking a small area at the entrance of the dispenser chute. This in turn restricts the flow of ice that is dispensed in to your cup.

Please refer to the instructions included in kit #5013822 for more information on how to install.

INSTALLATION

ROCKING CHUTE ICE DELIVERY SWITCH ADJUSTMENT

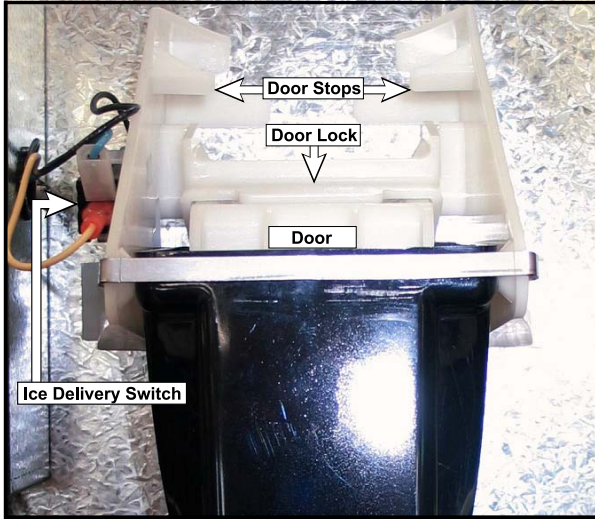

① To properly adjust the switch, first unplug the power cord to the unit then remove the merchandiser. This will give you access to the ice delivery switch located on the left side of the rocking chute.

② Begin by observing the chute by slowly pushing against the rocking chute. When the ice delivery switch clicks, measure the distance from the door stops on the rocking chute bracket to the door. The distance between the two should be no more than 1/4", but no less than 1/16".

③ The left side of the rocking chute has a tab that pushes up on the ice delivery switch. To adjust it, use needle nose pliers and bend the arm of the switch up or down in order to change the point where the tab makes contact with the switch arm.

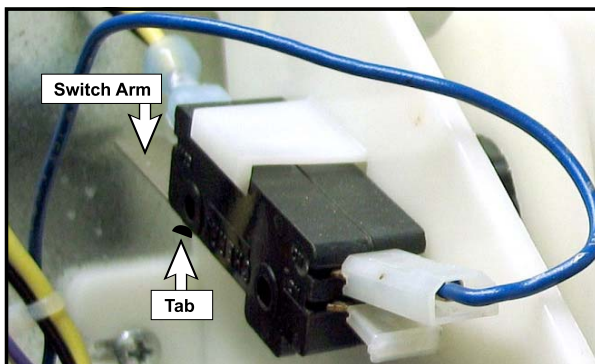
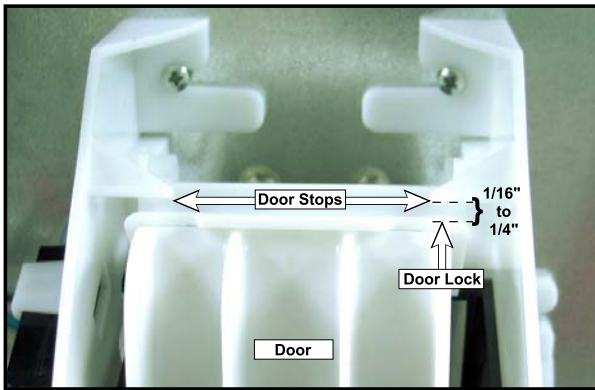

INSTALLATION

BAFFLE FOR MANITOWOC™ CUBERS

When installing a Manitowoc™ “S” series Ice Machine on a MII dispenser, a baffle kit is required for proper installation. The baffle kit is designed to prevent ice from lying against the front of the ice machine, and melting down the front of the dispenser. There are two different baffle kits available, one kit is for the 30" wide “S” series ice machine, and the other kit is for the 22" wide “S” series ice machine.

These two Kits are available through your local Manitowoc Distributor. List prices may be subject to change without notification. Please call your local parts distributor for current pricing before ordering.

Ice Maker Baffle Installation:

1. Remove both front panels.
2. Examine the ice machine to see if the machine has four screws on the lower front plastic panels.
3. If there are screws, remove them from the countersunk holes on the front surface of the machine, save the screws.
4. Install the deflector, using the four screws removed in step three.
5. Four screws and two backing plates are in the kit.
6. If there are no screws on the ice machine (step 2), pierce the thin plastic countersunk holes, install the backing plates and install the deflector using the screws from the kit.
7. Replace the front panels.

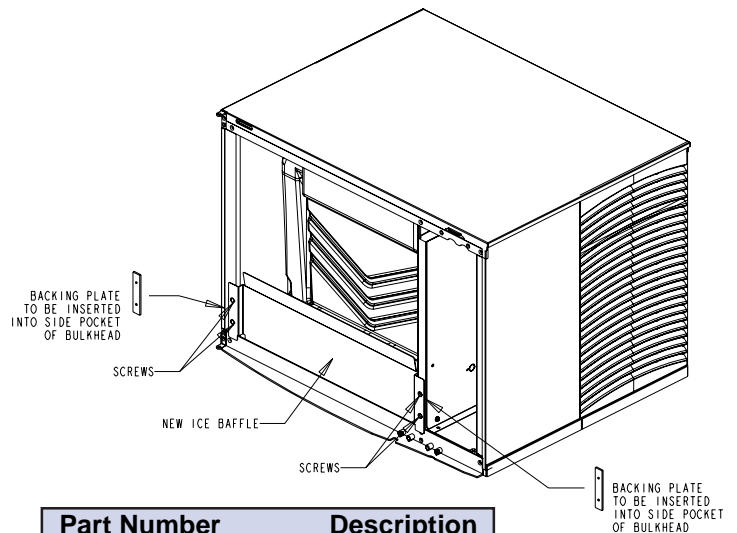

Part Number	Description
5029518	Baffle Kit 30"
5029517	Baffle Kit 22"

BAFFLE FOR "Q" SERIES ICE MACHINES

1. Position baffle on top of water well with tab on the front and the other tab inside the water well.
2. Mount the baffle on the left side of the ice maker using the hole and screw provided.

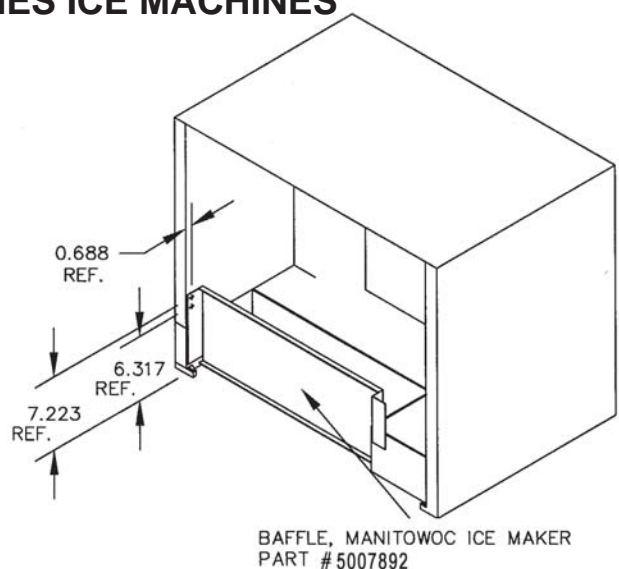

MANUAL FILL LID FOR DISPENSERS WITH A CUBER

If you are top mounting your MII Series dispenser with a cuber, you will require a lid for the manual fill area at the top, front of the dispenser.

If you ordered a dispenser and a cuber at the same time, the manual fill lid was included with the unit. The manual fill lid can be ordered from your local Multiplex distributor.

INSTALLATION

GENERAL INSTRUCTIONS FOR REMOVAL OF GEAR MOTOR

These instructions are provided as a guide for the removal of the gear motor. Depending on the model number of your dispenser, these instructions may vary slightly.

1. Disconnect power from the electric receptacle.
2. Remove all ice from the ice storage bin of the dispenser.
3. Remove the paddle wheel pin from the paddle wheel / agitator assembly inside the dispenser bin.
4. Remove the agitator assembly from the dispenser bin by pushing the agitator to the back of the bin. Angle the front of the agitator to the side. Pull the agitator forward then out of the dispenser.
5. Remove the paddle wheel from the dispenser by pulling the hub of the paddle wheel to the back of the bin and off the gear motor shaft.
6. Remove the splash panel from the dispenser and expose the gear motor.
7. Disconnect the electric connector from the gear motor wire leads.
8. Remove the pin in front of the gear motor.
9. You should be able to remove the gear motor from the dispenser.
10. To install a replacement gear motor, reverse this procedure.

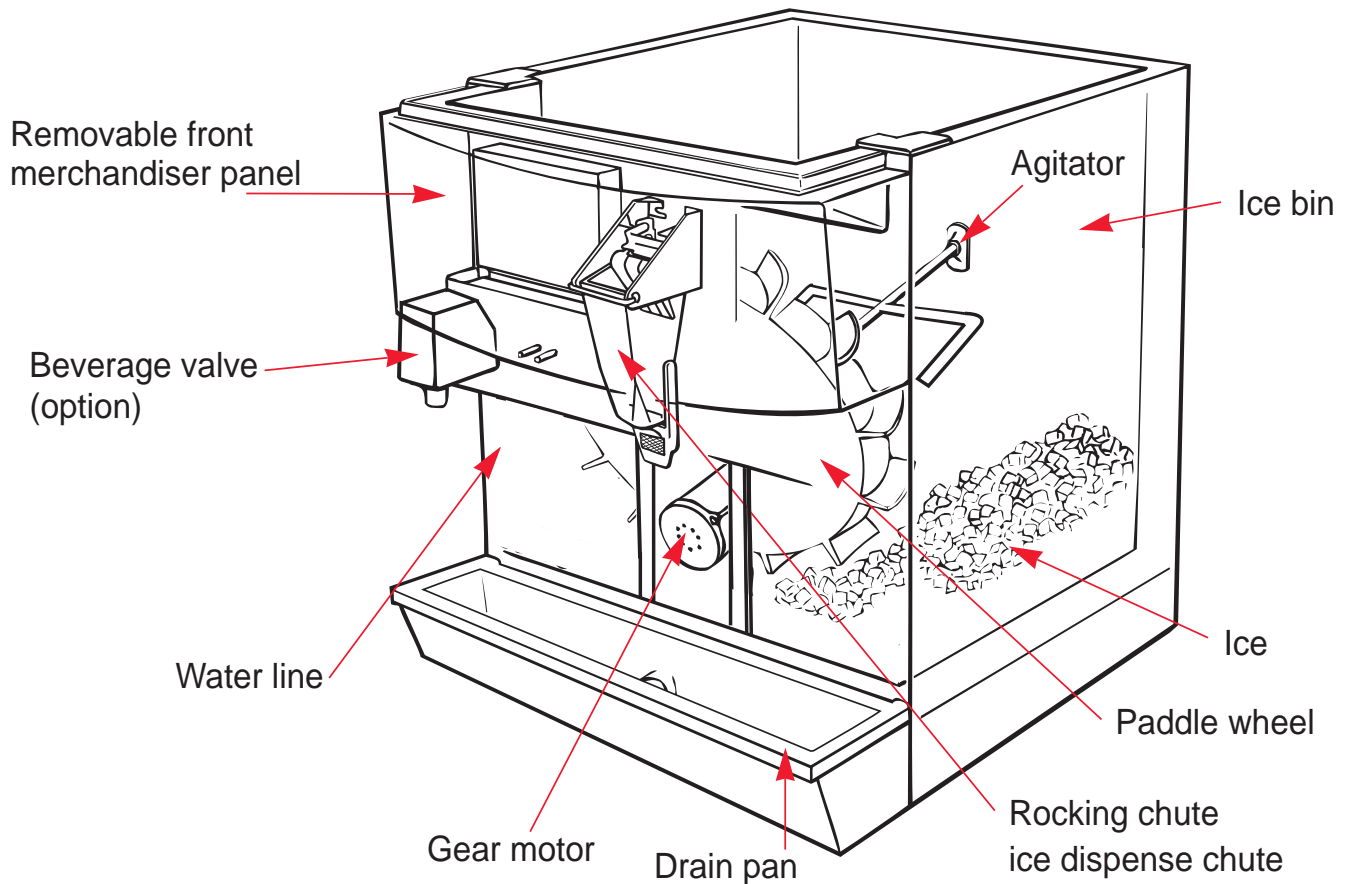

OPERATION

UNIT INSPECTION

Thoroughly inspect the unit upon delivery. Immediately report any damage that occurred during transportation to the delivery carrier. Request a written inspection report from a claims inspector to document any necessary claim.

ICE RECOMMENDED FOR DISPENSING

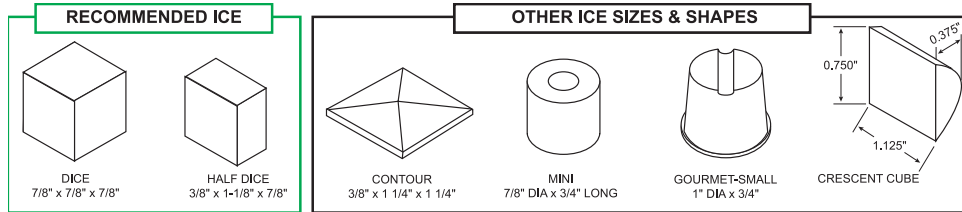

MII dispensers are designed to dispense hard, cube ice up to one-inch square. The ice shapes and sizes listed above are recommended for dispensing. **Warm “Super Cooled” Ice Before Dispensing** “Super Cooled” ice is not recommended for dispensing. “Super cooled” ice is ice that has been stored in freezers below 32°F. Should it be necessary to temporarily use “super cooled” ice, allow the ice to warm at room temperature for 25 to 30 minutes before placing the ice in the dispenser.

Dispensing compressed flake “nugget” ice in Servend dispensers takes special handling. Most dispensers require special bin components and a universal ice management kit. Contact MBE regarding details for your installation.

ICE STORAGE AND DISPENSING

As the customer presses the rocking chute, the arm at the top left rear of the chute pushes upward on the door lock. The door opens until it contacts the stops in the mounting brackets. The plastic arm on the ice chute also activates the lever of the ice dispensing switch. When activated, the micro switch starts the gear motor. The gear motor turns the paddle wheel and agitator arm.

The paddlewheel carries ice. Periodic agitation is optional on the MII-150 and MII-175 and is standard on the MII-200, MII-250, MII-302 and MII-402. During periodic agitation, the paddle wheel and agitator turn for approximately three seconds every three and one half-hours. The door lock prevents ice from being dispensed during the agitation cycle.

BEVERAGE VALVES

Post-mix beverage valves are designed to precisely meter the flow of both water and syrup to obtain the proper mixing ratio. The syrup and soda water components of the post-mix beverage are mixed as they leave the beverage valve.

LEGS

Legs are optional equipment with most MBE dispensers. Standard legs are four-inch (10.2 cm) tall stainless steel legs. MII 302 and MII 402 cannot be placed on legs. When installing legs on a MII Series dispenser, leg braces should be used. These are metal braces fitting side to side under the dispenser that reinforce the leg attachment area. It is recommended if an icemaker is installed on top of the dispenser, legs should not be installed.

115V/220V NON ADJUSTABLE AGITATION TIMER

The agitation timer on this unit is equipped with test pins. This allows you to test the timer by removing the jumper between the two pins. When the jumper is removed the timer will cycle every 55 seconds if it is operating correctly. If the timer is wired correctly and does not cycle approximately every 55 seconds when the jumper is removed, replacement of the timer may be necessary. Make sure to replace the jumper pins when finished.

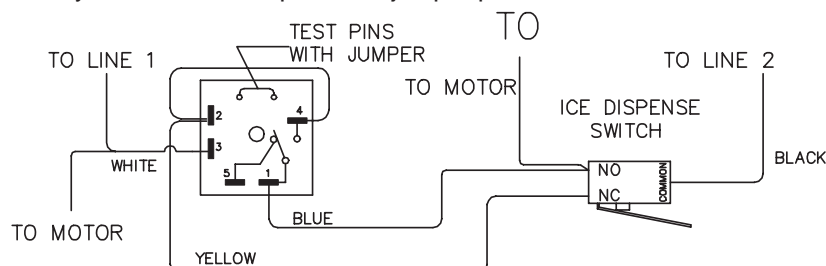

NOTES: This timer is re-settable, timed agitation every 3.5 hours from last dispense on power supply broken. Never operate in normal mode without test pins in place, damage could occur.

OPERATION

MII MEASUREMENTS & SPECIFICATIONS



	MII-150	MII-175	MII-200	MII-250
Standard Features	Lighted Merchandiser, "ice" graphics, key switch, stainless steel legs, drain kit, and timed agitation is standard on MII-200 and MII-250.			
Dimensions	22" W x 30.5" D x 33" H (add 1.25"to height for lid)	24" W x 30.5" D x 35" H (add 1.25"to height for lid)	30" W x 30.5" D x 33" H (add 1.25"to height for lid)	30" W x 30.5" D x 39" H (add 1.25" to height for lid)
Shipping Weights	152 lbs./69 kgs.	160 lbs./72.7 kgs.	171lbs./77.7kgs.	199 lbs./90.5 kgs
Countertop Weight	119 lbs./54.1 kgs.	124 lbs./56.4 kgs.	133 lbs./60.5 kgs.	175 lbs./79.5 kgs
Ice Storage Capacity	150 lbs./ 68 kgs. of ice.	up to 175 lbs./ 79 kgs.of ice.	up to 200 lbs./ 91 kgs.of ice.	up to 250 lbs./ 114 kgs.of ice.
Electrical Requirements	Dispenses: 120V/60Hz/2.8 FLA 220V/50Hz/1 Also Available			
Drain	Two 3/4" (1.96cm) PVC (N.P.T.) drain fittings, (one pre-installed 3/4" (1.96cm) PVC fitting extends from drain pan. A second fitting extends from bin.)			
Ice Machine Compatibility	Manual fill or top-mount with compatible 22"and 30" wide ice machines. Contact factory for baffle and ice maker lid requirements. Top-mounted ice machines may reduce ice storage capacity			
Graphic Area Dimensions	Physical trim - 21.5"W x 10.5"H 54.61W x 26.67H (cm) Visual area - 20.5"W x 9.5"H 52.07W x 24.13H (cm)	Physical trim 12.75" H x 37.312" W 32.39 W x 94.772 (cm) Visual area 11" H x 35.813" W 27.94 W x 90.965H (cm)	Physical trim: 29.312" W x 10.625" H 74.452W x 27.056H (cm) Visual area: 28.312" W x 9.625" H 71.912W x 24.448H (cm)	Physical trim: 29.5" W x 16.625" H 74.93W x 42.228H (cm) Visual area: 28.5" W x 15.625" H 72.39W x 39.688H (cm)
Service	Motor, drain and electrical connections are front serviceable.			
Options	Flomatic beverage valves, extended splash panel, splash guards, adapter kits for top-mounted ice machine applications, timed agitation for MII-150 and MII-175. Other valves also available.			

OPERATION

MII-302 MEASUREMENTS & SPECIFICATIONS

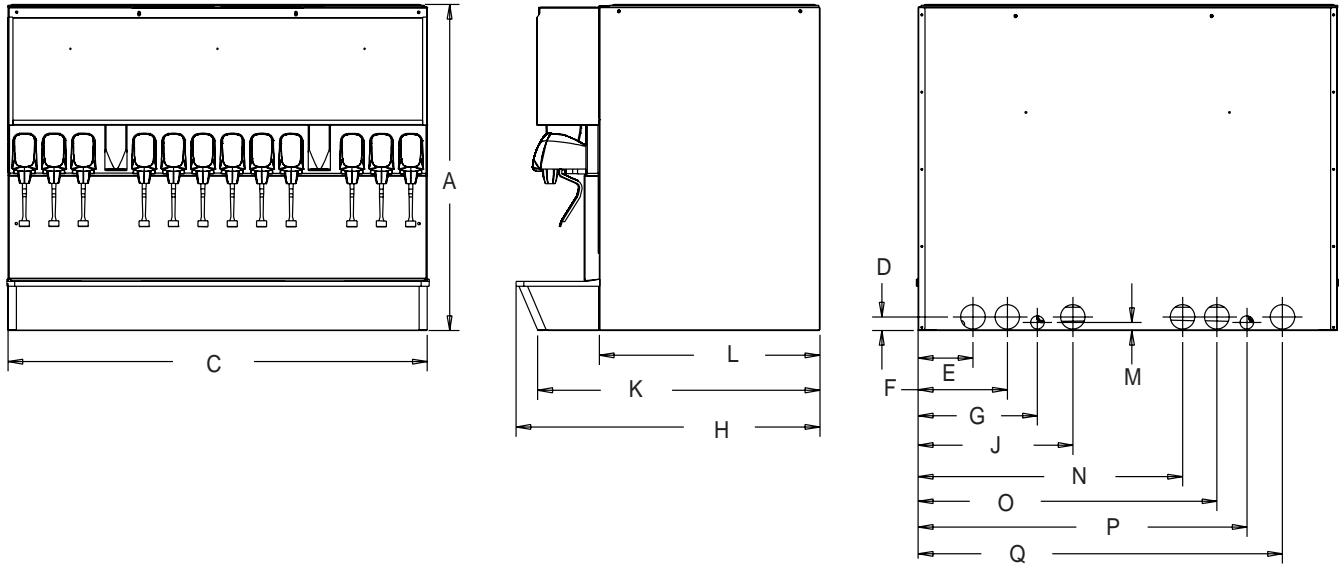

Unit	A	B	C	D	E	F	G	H	J	K	L	M	N	O	P	Q
MII-302	33.25"	12.50"	42.75"	1.38"	5.59"	9.10"	12.16"	31.00"	15.78"	28.78"	22.50"	.82"	26.97"	30.47"	33.75"	37.16"

MII-302	
Standard Features	Key Switch, Drain Kits, 12" high lighted merchandiser and timed agitation
Dimensions	42.75" W x 31" D x 34.25" H (inches) 108.6 W x 78.74 D x 87 H (cm)
Shipping Weights	470 lbs. / 213 kgs.
Countertop Weights	402 lbs. / 182 kgs.
Ice Storage Capacity	300 lbs. / 136 kgs.
Electrical Requirements	Dispenser: 120V/60Hz/3.5FLA
Drain	Two pre-installed 3/4" (1.9 cm) PVC (N.P.T.) drain fittings extends from drain pan. Ice bin drains directly into drain pan for front clean out, no hook up necessary.
Machine Compatibility	Manual fill or top-mount with compatible 30" wide ice machine. Certain top-mounted machines may reduce storage capacity. Contact distributor or MBS for baffle and ice maker lid requirements for top-mounted ice machine applications.
Graphic Area Dimensions	Standard Physical trim - 42.625" W x 11" H (108.2 W x 27.94 H (cm)) Visual area - 41.75" W x 10.062" H; (106 W x 25.56 H (cm)) Extended Merchandiser: Physical trim - 42.5" W x 23.813" H (107.95 W x 60.49 H (cm)) Visual area - 41.624" W x 22.875" H (105.72 W x 58.1 H (cm))
Service	Motor, drain and electrical connections are front serviceable.
Options	The MII-302 will accommodate up to 12 Flomatic 464 (at 3-4 oz/sec) beverage valves. F-464 valves are available in sanitary lever, push button, Autofill lever and portion control. Other valves available, contact factory for details. Leg kits not available for MDH-302. Other options: regulators, carbonator, side water lever installation kits and side splash panels.

OPERATION

MII-402 MEASUREMENTS & SPECIFICATIONS

Front view

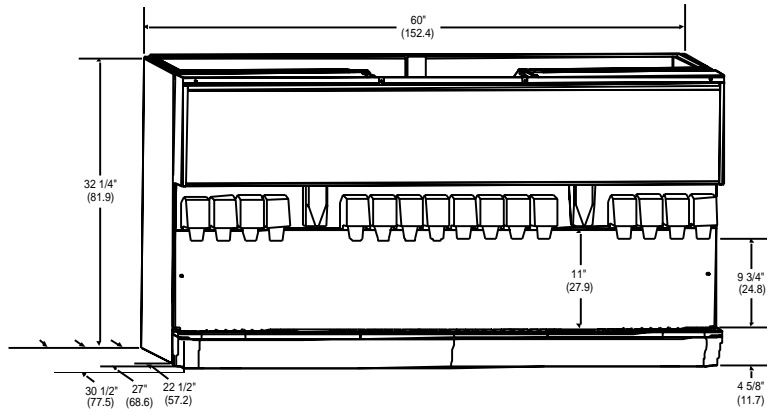

Back view

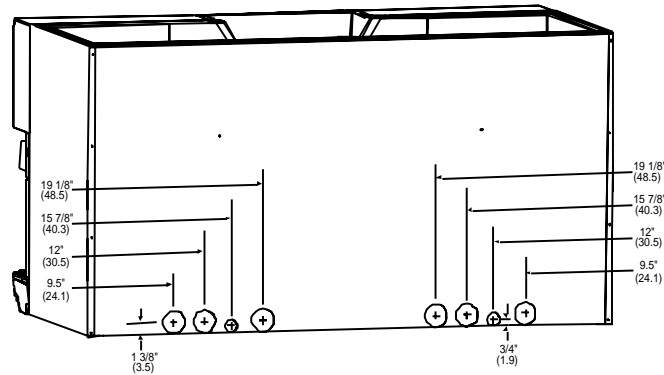

Bottom view

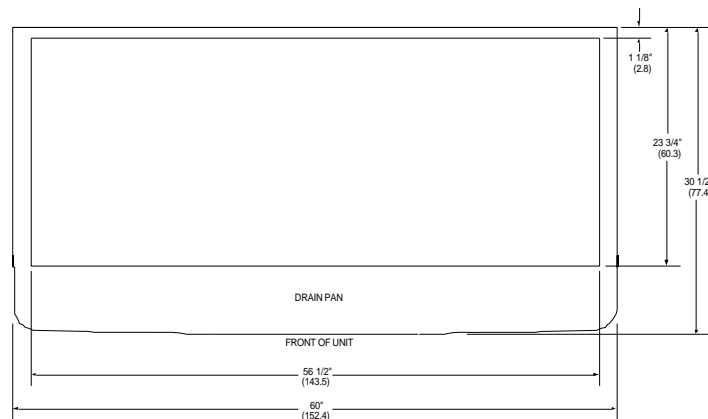

OPERATION

MII-402 MEASUREMENTS & SPECIFICATIONS

Standard Features for the MII-402:

Timed agitation, lighted merchandiser (MM), graphics, key switches (DS) and drain kits (DRK). Leg kits not available for this unit.

Dimensions:

60" (152.4 cm) W x 30.5" (77.5 cm) D x 32.25 (81.9 cm) H

Ice Storage Capacity:

400 lbs. (181.82 kg)

Cooling Capacity:

At 75°F (23.9°C) ambient temperature. Up to 8 (12 oz.) drinks per minute can be dispensed at or below 40° F (4.4°C) provided ice is in full contact with the cold plate.

Cabinet and Ice Bin:

Stainless steel

Cold Plate:

16 valve: 19.85"W x 28.23"H; Two 12 circuit cold plates each with 3-1-1-3 manifold.

20 valve: 19.85"W x 28.23"H; Two 15 circuit cold plates each with 3-1-2-1-3.

Electric:

Models available in 120/60/1; 8 foot, three-wire cord and plug provided.

Amperage:

4.5 FLA standard merchandiser; 5.0 FLA 34" extended merchandiser.

Drain:

Four 3/4" PVC drain fittings, (two pre-installed 3/4" PVC (N.P.T.) drain fittings extend from drain pans and two pre-installed 3/4" PVC (N.P.T.) drain fittings extend from each bin.) Unit can be drained from the bottom or the back of the unit.

Graphic Area Dimensions:

Physical trim area on merchandisers:

1 2 T: 60"W x 12"H x 6 3/8"D

2 4 T: 60"W x 24"H x 7 1/4"D

3 4 T: 60"W x 34"H x 7 1/4"D

Ice Cube Compatibility:

Dispenses cube ice up to one inch square. Flake ice is not compatible. Compatible with most 30" or 48" wide ice machines. Contact factory for details.

Ice Machine Compatibility:

Front or side manual fill or top mount with any single 30" or 48" wide ice machine. Certain top mounted cubers may reduce storage capacity. Contact distributor or factory for baffle and special lid requirements for top-mounted cuber applications.

Service:

Drain pan, beverage valves, (optional) cold plate hook ups, drain connections and electrical components are all front serviceable.

Ship Weight:

600 lbs (272 kg)

Counter Top Weight (without ice):

500 lbs (227 kg)

Options:

16 or 20 Flomatic valves (fast flow, push button, sanitary lever, or portion control).

Other options include: Water dispenser, carbonator, regulator and installation kits.

* Continuing product improvements may necessitate change of specifications without notice. Manufactured under Patent Nos.: 4,930,685 and 4,641,763. Other Patents Pending.

OPERATION

MII-250 FOOTPRINT

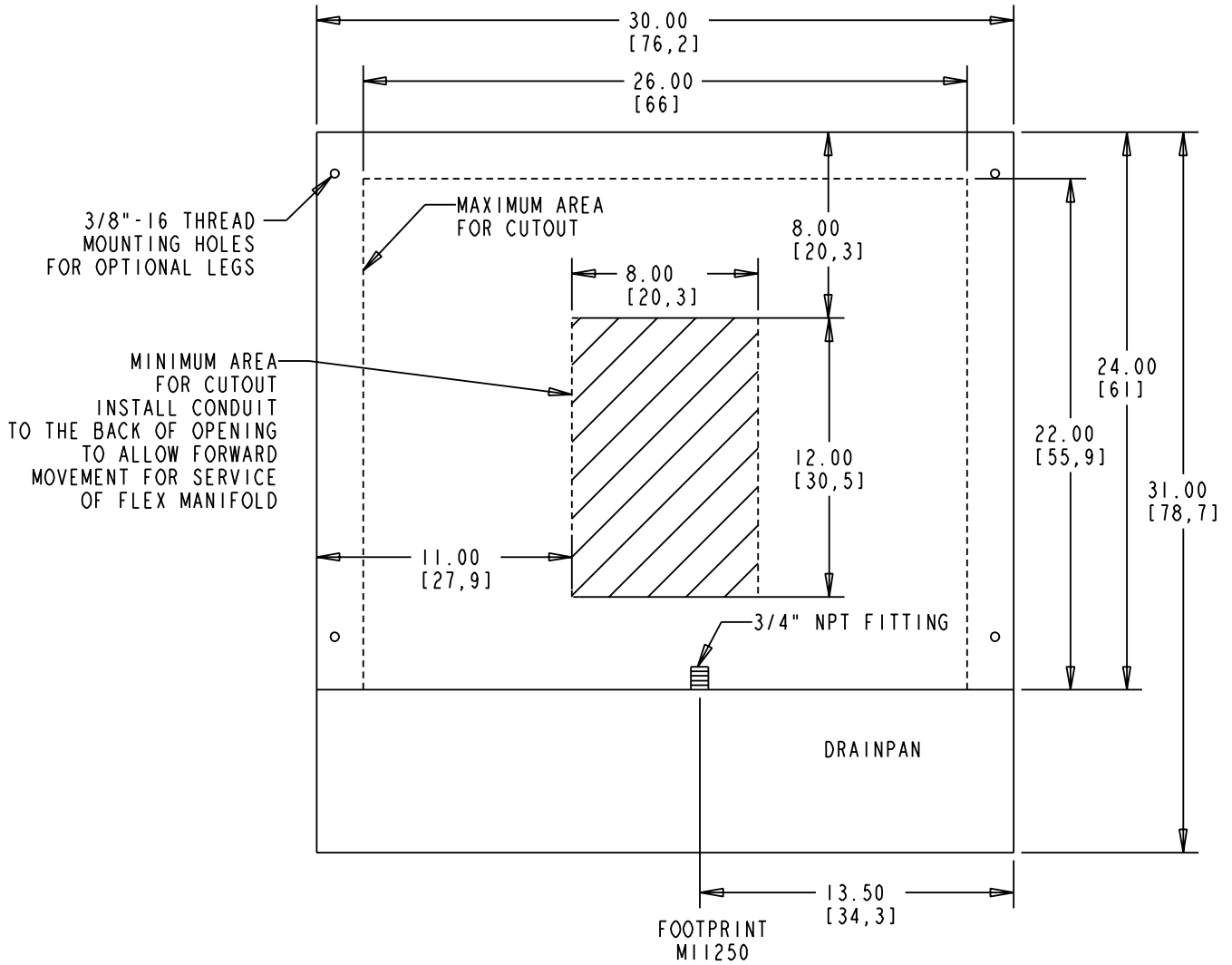

 **CAUTION:** *Cutting the countertop may decrease its strength. Counter should be braced to support the dispenser countertop weight plus ice storage capacity and weight of icemaker, if applicable.*

OPERATION

MII-302 FOOTPRINT

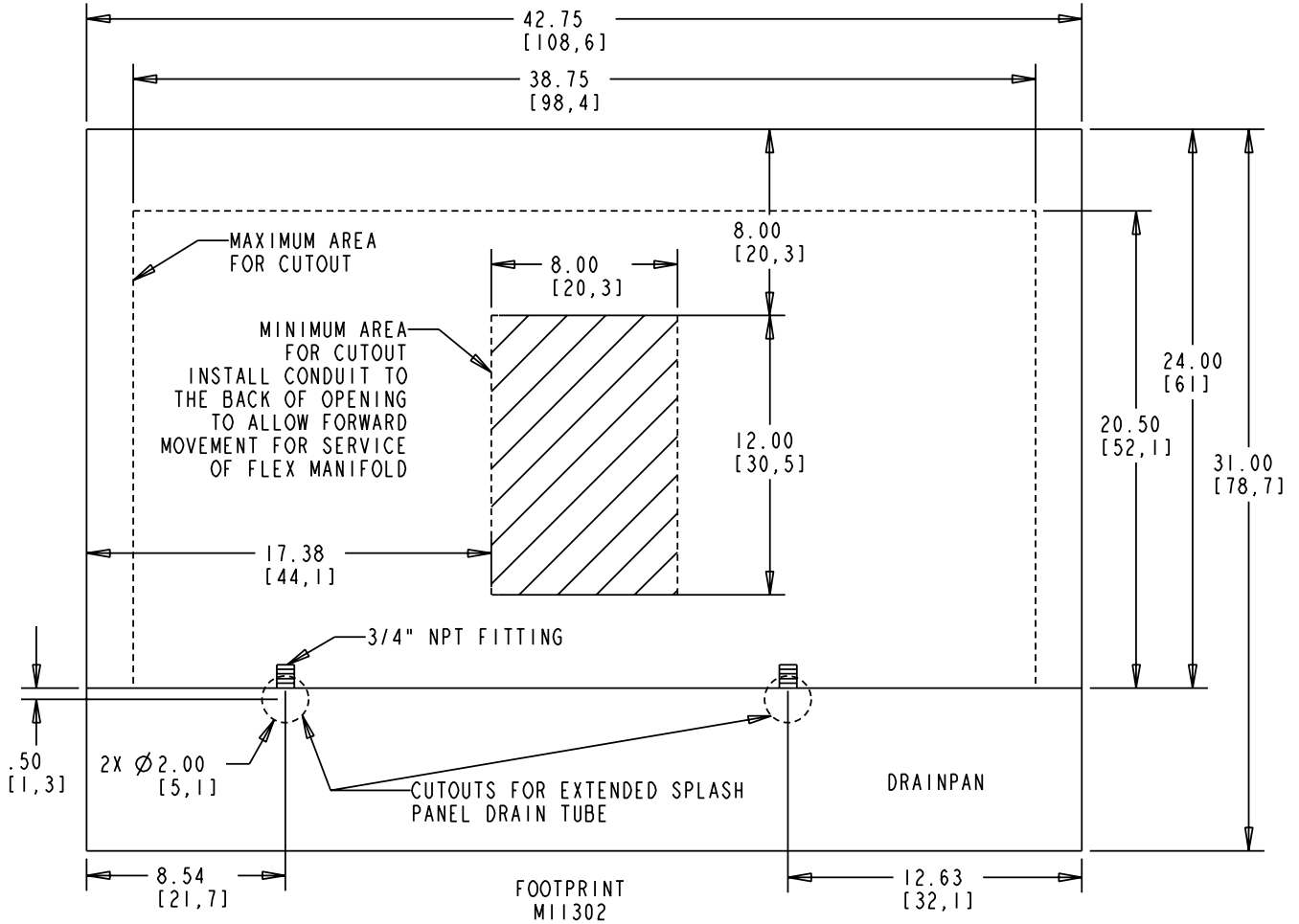

CAUTION: *Cutting the countertop may decrease its strength. Counter should be braced to support the dispenser countertop weight plus ice storage capacity and weight of icemaker, if applicable.*

USER MAINTENANCE

SANITIZING AND CLEANING



NOTE: This cleaning schedule is a recommendation. Scheduled cleaning must be in compliance with local health codes.

DAILY CLEANING

- Drain pan
- Grid
- Splash panel

You will need: Warm, clean water to wash and rinse with, mild non-abrasive soap and a clean cloth.

1. Lift the grid and remove it from the drain pan.
2. Using mild soap, warm water and a clean cloth, wipe the drain pan and splash panel. Then, rinse with clean, warm water. Allow plenty of warm (not hot) water to run down the drain of the drain pan, to remove residue that can clog the drain opening.

WARNING! Do not pour hot coffee into the drain pan. Pouring hot coffee down the drain pan can eventually crack the drain pan, especially if the drain pan is cold or still contains ice.

3. Wash the grid, then rinse with clean water. Place the grid back in the drain pan.
4. Wash all exterior surfaces of the unit with warm water and a clean cloth. Wipe again with a clean, dry cloth.
5. Rinse nozzle and diffuser with warm, clean water.

CLEANING AND SANITIZING THE DISPENSER

1. Mix a solution of mild detergent to clean the dispenser bin and components.

2. Using the mild detergent solution, a soft bristle brush or clean cloth, clean the following dispenser parts:

- Entire bin
- Paddle wheel
- Paddle wheel area
- Agitator
- Paddle wheel pin
- Ice Chute
- Rear bushing
- Motor shaft
- Strip lids on model MII-302 & 402

3. Rinse all the parts in clean, running water.

4. Mix a sanitizing solution of 1/4 ounce of liquid, unscented laundry bleach (5.25% Cl Na O concentration) for each gallon of water. Or mix a solution of water and sodium hypochlorite mixed to yield 100 PPM of available chlorine.

Or mix a solution of any approved sanitizer, following the directions for mixing and applying the sanitizer.

5. Using the sanitizing solution, a soft bristle brush or clean cloth, sanitize the dispenser parts listed in step 2 above.

RE-ASSEMBLING THE DISPENSER PARTS

1. Re-assemble parts in the following order:

- Paddle wheel area
- Bin liner
- Paddle wheel
- Agitator
- Paddle wheel pin
- Ice chute
- Merchandiser

2. Hand tighten all knurled fasteners.

3. Pour in fresh, sanitary ice and replace the plastic lid on the top of the dispenser.

4. Plug in the unit's electrical cord.

5. Check for proper ice dispensing.

USER MAINTENANCE

PREVENTATIVE MAINTENANCE

Preventative maintenance is a vital part of keeping your MII dispenser in top condition. Following the guidelines below will assist you in continued trouble free operation of your unit.

1. Conduct daily maintenance of the machine.
2. Perform monthly maintenance of the machine.
3. Perform periodic maintenance and sanitizing of beverage system.
4. Do not overflow the dispenser bin with ice.
5. Do not allow the dispenser to sit for prolonged periods of non use with ice in the bin.
6. Most ice dispenser service problems are caused by low usage of the ice dispenser.
7. Do not allow ice to remain in the bin more than a day in order to prevent ice from freezing together and/or stagnant ice.

Possible excess ice storage reasons:

- Storage capacity exceeds daily requirements.
- Low demand during the off season.
- Dispenser oversized with future growth in mind.

Lower ice storage to meet one day's needs. If you manually fill ice, fill only with the appropriate amount of ice. Fill the dispenser with fresh ice each morning. Do not fill the dispenser at night just before shut down. Ice cubes can freeze together if not dispensed.

Contact MBE at 1-800-367-4233 for more information about our **ProActive Maintenance Program**.

HOW TO DISASSEMBLE FOR CLEANING OR MAINTENANCE

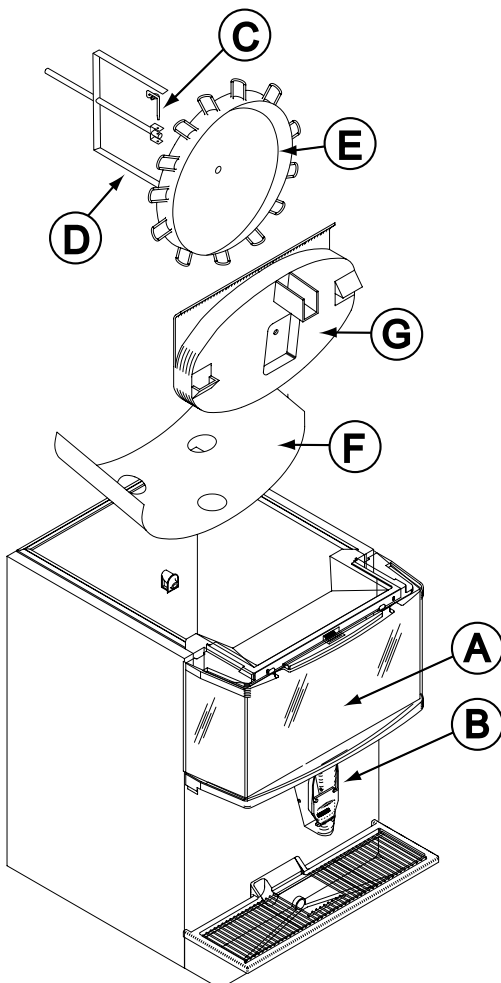
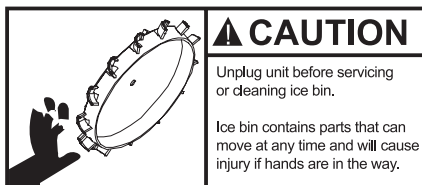

NOTE: Sanitize the ice dispenser at Initial Start-UP in addition to monthly sanitizing. You will need screwdriver in order to disassemble.

Disassemble parts in the following order:

- A. Merchandiser
- B. Ice chute
- C. Paddle wheel pin
- D. Agitator
- E. Paddle wheel
- F. Bin liner
- G. Paddle wheel Area

Accessing a Dispenser Bin Top Mounted with a Manitowoc Cuber:

1. Remove the front panel of the ice machine.
2. Remove the ice deflection baffle. This will give you access to the dispenser bin.

Accessing a Dispenser Bin that is Top Mounted with a Manitowoc Cuber and Large Extended Merchandiser in front of the Cuber:

1. Access to the bin is possible through the strip lids on the side of the Dispenser.

Disassembling the Dispenser Parts for Bin Cleaning:

1. Remove the front panel of the Manitowoc ice maker.
2. If the Manitowoc ice maker is operating, wait for the sheet of ice to fall into the dispenser bin. When the ice sheet falls into the dispenser bin, immediately place toggle switch of the ice machine to the "OFF" position.
3. If the Manitowoc ice maker is NOT operating, place the toggle switch of the ice machine to the "OFF" position.
3. On MD models without a top mounted cuber, remove the plastic lit from the top of the dispenser.
4. Remove all ice from the dispenser.
5. Disconnect electrical power to the dispenser.
6. On the MD-302 dispenser only, remove the strip lids off the top left and top right of the dispenser bin.
7. For the MD-302 dispenser only, there is a left bin and a right bin. Clean and sanitize one bin, then follow the same procedures on the second bin.

USER MAINTENANCE

HOW TO DISASSEMBLE FOR CLEANING OR MAINTENANCE

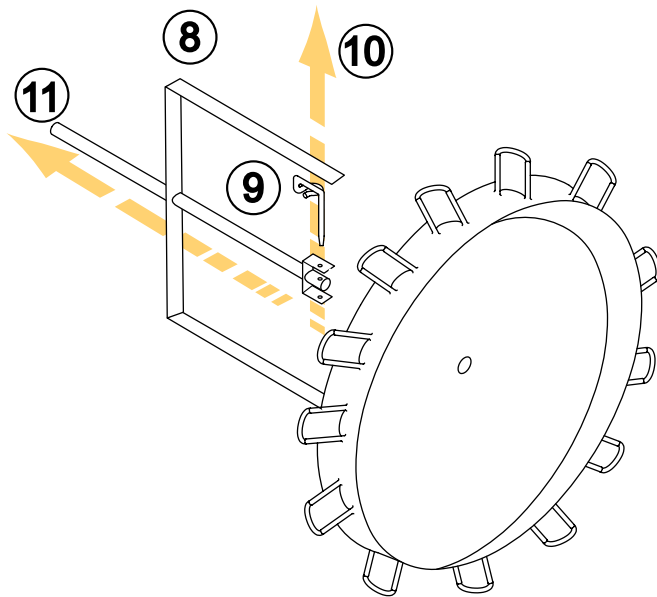

Agitator arm and paddlewheel pin:

8. Rotate the agitator arm so the paddle wheel pin handle is pointing up, toward the ceiling. For the MD-302 dispenser only, reach inside the bin through the area where the strip lid has been removed.
9. Loosen the hand-removable paddle wheel pin from the agitator by twisting counter clockwise until it snaps from the agitator bar...
10. ... Then remove the paddle wheel pin from the hole in the agitator.
11. Push the agitator bar toward the back of the unit until the agitator is free of the paddle wheel hub.

Paddlewheel, bin liner and paddle wheel area:

12. Move the front of the agitator to one side and slide the agitator forward until the rear of the agitator shaft is clear of the bushing.
13. Remove the agitator from the bin area.
14. Slide the paddle wheel from its shaft.
15. Loosen the four knurled fasteners that hold the bin liner in place.
16. Remove the bin liner.
17. Remove the paddle wheel area from the bin. For the MD-302 dispenser only, remove the paddle wheel area to the back of the bin.
18. Discard the remaining ice in the bin.

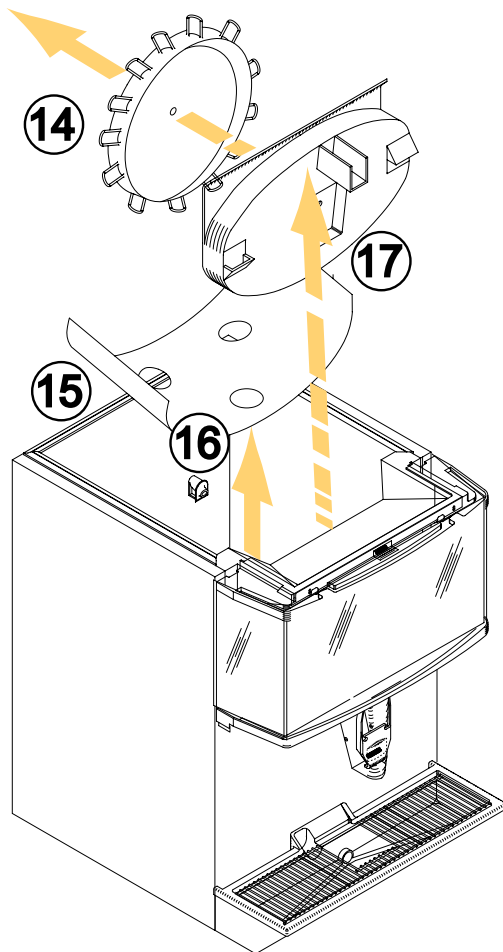

USER MAINTENANCE

HOW TO DISASSEMBLE FOR CLEANING OR MAINTENANCE

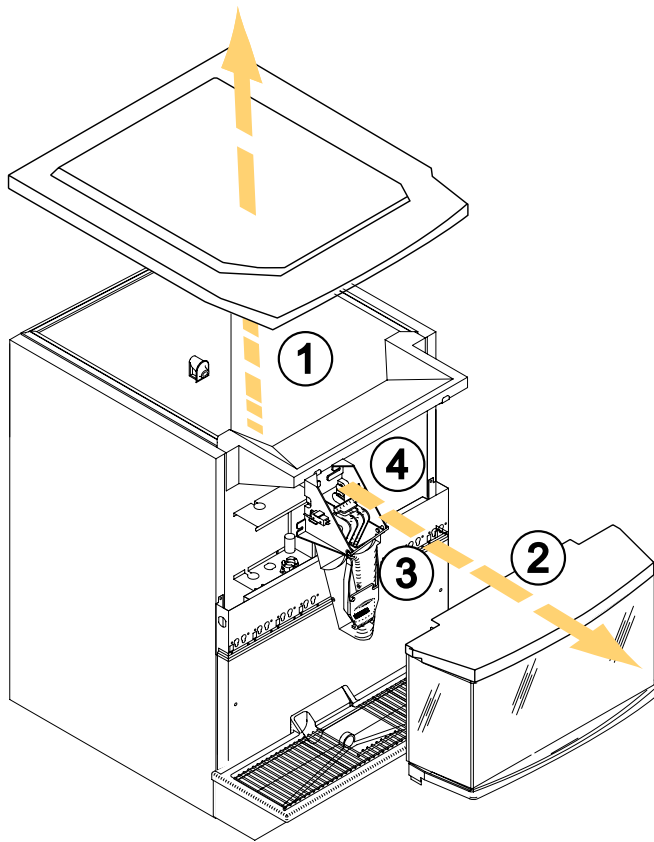

Disassemble the rocking chute:

1. Loosen the two knurled fasteners that hold the merchandiser in place.
2. Remove the merchandiser.
3. Remove outer bracket.
4. Remove door lock.
5. Remove door.
6. Remove ice chute.
7. Model MD-302 has two rocking chutes. Remove both rocking chutes using the same procedure above.

Disassemble the solenoid style chute:

1. Loosen the knurled fastener on both sides of the outer chute and remove chute from the dispenser.

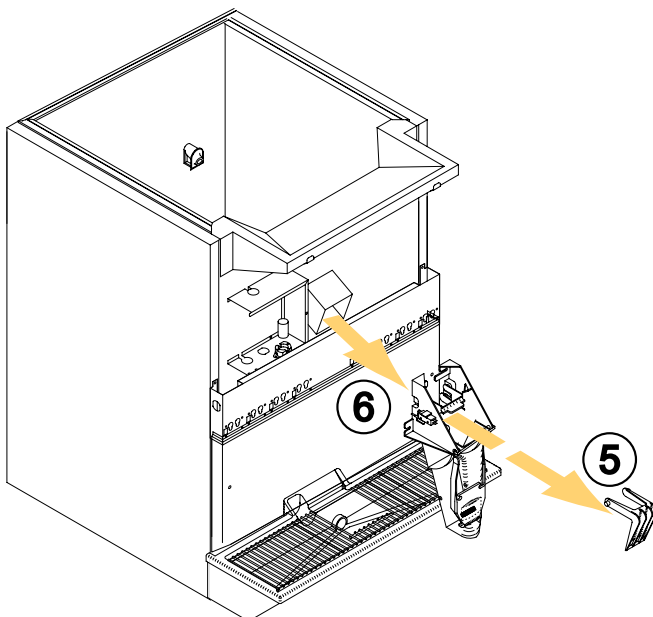

USER MAINTENANCE

DAILY CLEANING

All cleaning must meet your local health department regulations. The following cleaning instructions are provided as a guide.



CAUTION: Use only warm soapy water to clean the exterior of the tower. Do not use solvents or other cleaning agents. *Do not pour hot coffee into the drain pan. Pouring hot coffee down the drain pan can eventually crack the drain pan, especially if the drain pan is cold or still contains ice.*

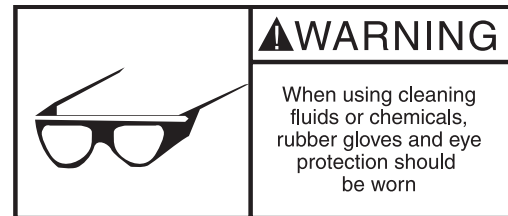
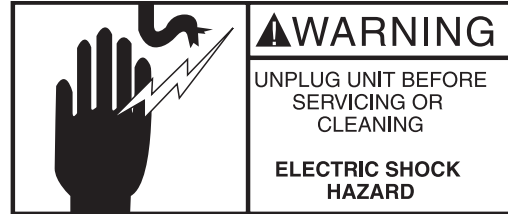
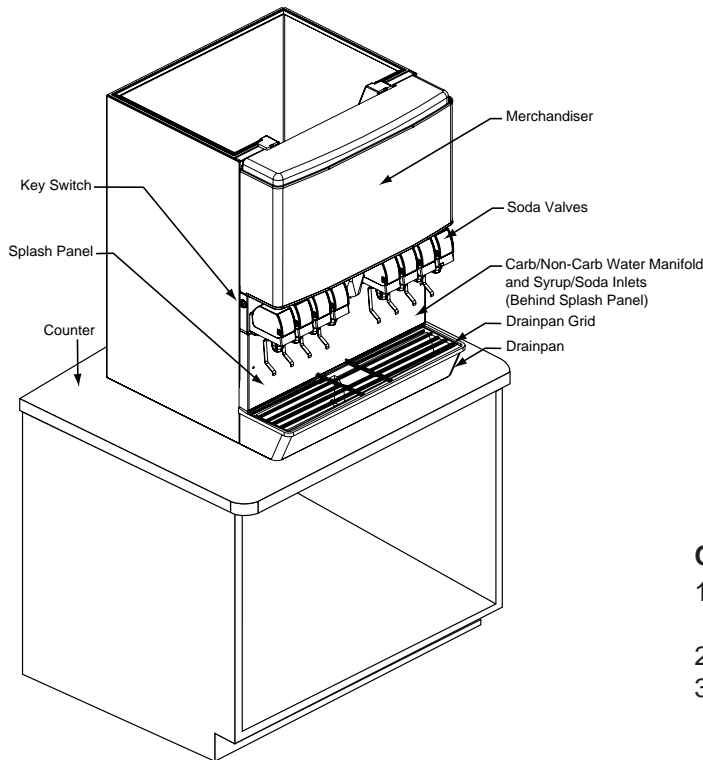

Clean the exterior and drain pan:

1. Turn off the key switch located on either right or left side of the unit.
2. Lift the grid and remove it from the drain pan.
3. Using mild soap, warm water and a clean cloth, wipe the drain pan and splash panel. Then, rinse with clean, warm water. Allow plenty of warm (not hot) water to run down the drain of the drain pan, to remove syrup residue that can clog the drain opening.
4. Wash the grid, then rinse with clean water. Place the grid back in the drain pan.
5. Wash all exterior surfaces of the unit with warm water and a clean cloth. Wipe again with a clean, dry cloth.

Clean the dispensing valves:

6. Remove nozzles and diffusers from beverage valves.
7. Rinse nozzle and diffuser with warm, clean water.
8. Clean nozzles and diffusers with soapy water and a soft bristle brush.
9. Clean the underside of the beverage valves with warm, soapy water. Rinse with clean damp towel.
10. Replace nozzles and diffusers on valves.
11. Turn on the key switch.

USER MAINTENANCE

MONTHLY CLEANING

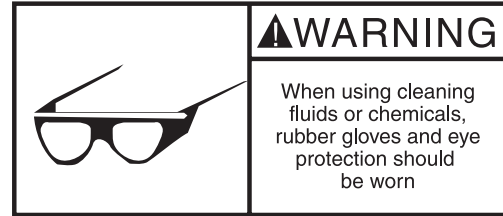
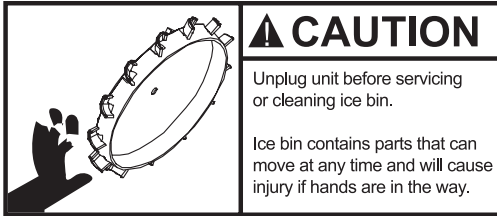

Clean and sanitize the ice bin:

1. Unplug unit and remove all ice from the ice bin.
2. Mix a solution of mild detergent to clean the dispenser bin and components.
3. Wash the ice bin using a sponge and the mild detergent solution.
4. Using the mild detergent solution and a soft bristle brush or clean cloth, clean the following dispenser parts:
 - Entire bin
 - Paddle wheel
 - Paddle wheel area
 - Agitator
 - Paddle wheel pin
 - Ice Chute
 - Rear bushing
 - Motor shaft
 - Strip lids (where applicable)
5. Rinse all the parts in clean, running water.
6. Prepare 2 gallons of sanitizing solution by mixing a 1/2 ounce of household bleach (that contains 5.25% sodium hypochlorite) with 2 gallons of 120°F water. The mixture should not exceed 100 PPM of chlorine. Or mix a solution of any approved sanitizer, following the directions for mixing and applying the sanitizer..
7. Sanitize the ice bin and cold plate with the sanitizing

solution for at least 10 seconds.

8. Allow to air dry. Do not rinse.

Re-assembling the dispenser parts:

9. Re-assemble parts in the following order:
 - Bin liner
 - Paddle wheel
 - Agitator
 - Paddle wheel pin
 - Ice chute
 - Merchandiser
10. Hand tighten all knurled fasteners.
11. Pour in fresh, sanitary ice and replace the plastic lid on the top of the dispenser.
12. Plug in the unit's electrical cord.
13. Check for proper ice dispensing.

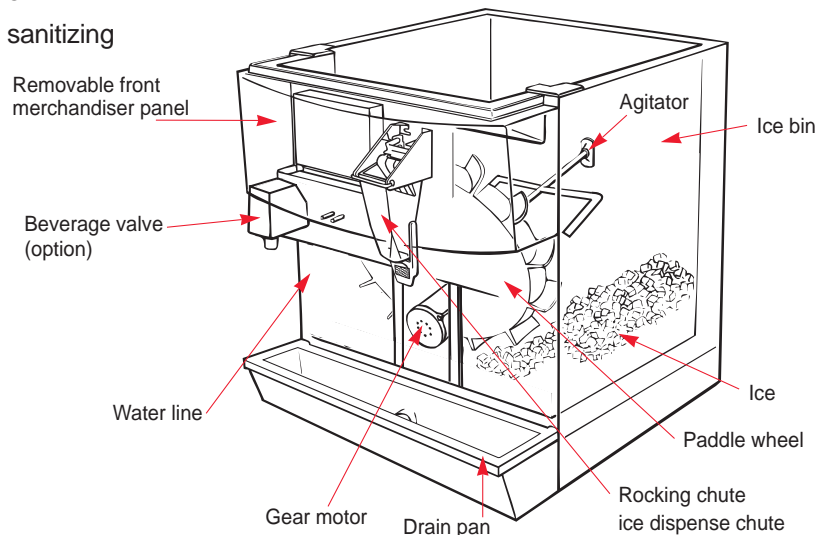

EXPLODED VIEWS, PARTS & DIAGRAMS

MII-150, 175, 200, & 250

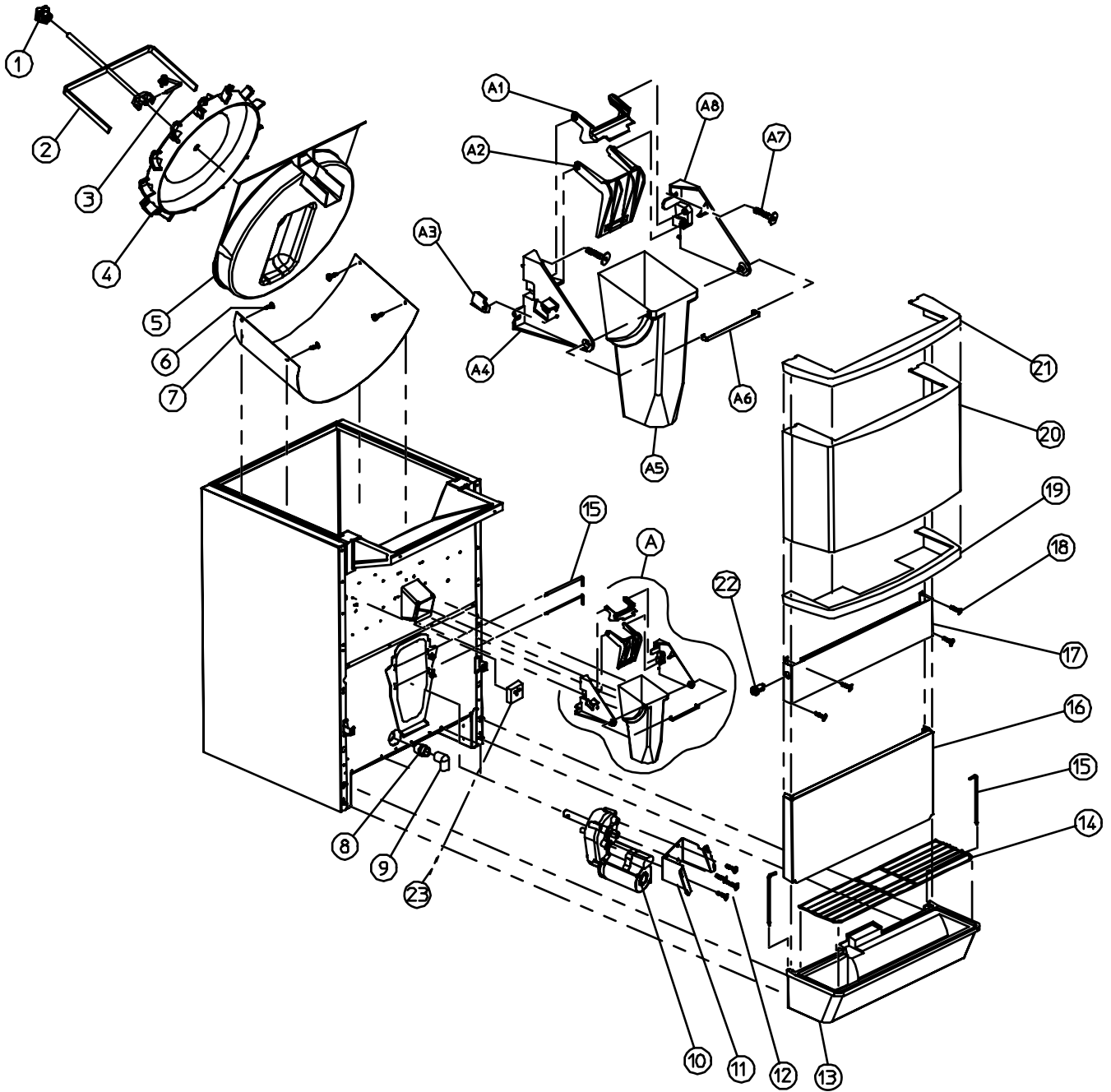

EXPLODED VIEWS, PARTS & DIAGRAMS

MII-150 PARTS LIST

INDEX NUMBER	PARTS DESCRIPTION	PART NUMBER	INDEX NUMBER	PARTS DESCRIPTION	PART NUMBER
1	MUSHROOM BUSHING	0101702	A	WIDE ROCKING CHUTE ASSEMBLY	5008476
2	U-BAR AGITATOR	5009529	A1	DOOR LOCK	5002509
3	U-BAR AGITATOR PIN	5010452	A2	DOOR	5002508
4	PADDLE WHEEL	2601415	A3	MICROSWITCH	1000703
5	PADDLE WHEEL AREA	5001051	A4	DOOR MOUNT LEFT	5002507
6	SCREW 8-32X1/2" KNURL UNSLT (4X)	5000711	A5	WIDE ROCKING CHUTE	5002506
7	BIN LINER	5030667	A6	BRACKET	5031384
8	DRAIN FITTING 3/4"	1200121	A7	SCREW 8-32X1/2" ZNC PH RD F (4X)	5000973
9	DRAIN ELBOW 3/4" FEMALE	1200117	A8	DOOR MOUNT RIGHT	5002657
10	MOTOR AY-62	5000868	--	LEVER (OPTIONAL)	5008351
11	MOTOR MOUNT	5001776			
12	BOLT 1/4-20X5/8" SS HHCS (4X)	0900601			
13	DRAINPAN STD BLACK W/GRID	5010894			
14	GRID STD	5010684			
15	RETAINING PIN (2X)	4140023			
16	SPLASH PANEL STAINLESS STEEL	5028118			
17	CAP MERCH SUPPORT	5010949			
	CAP MERCH SUPPORT W/ LEFT WATER	5011428			
	CAP MERCH SUPPORT W/ RIGHT WATER	5011433			
18	SCREW 8-32X1/2 ZNC PH RD F (4X)	5000973			
19	MERCHANDISER (BLACK)	5010609			
20	MEDALLION ICE	5012000			
	MEDALLION QUENCH	5007046			
21	MERCHANDISER TOP (BLACK)	5010269			
22	KEY SWITCH	5000220			
23	TIMER AGITATION 115V NON-ADJUSTABLE	5029024			

* FOR CUSTOMIZED OPTIONS, SUCH AS GRAPHICS, PLEASE CONTACT THE LOCAL SALES REPRESENTATIVE

MII-175 PARTS LIST

INDEX NUMBER	PARTS DESCRIPTION	PART NUMBER	INDEX NUMBER	PARTS DESCRIPTION	PART NUMBER
1	MUSHROOM BUSHING	0101702	A	WIDE ROCKING CHUTE ASSEMBLY	5008476
2	U-BAR AGITATOR	5009529	A1	DOOR LOCK	5002509
3	U-BAR AGITATOR PIN	5010452	A2	DOOR	5002508
4	PADDLE WHEEL	2601415	A3	MICROSWITCH	1000703
5	PADDLE WHEEL AREA	5001051	A4	DOOR MOUNT LEFT	5002507
6	SCREW 8-32X1/2" KNURL UNSLT (4X)	5000711	A5	WIDE ROCKING CHUTE	5002506
7	BIN LINER	5030667	A6	BRACKET	5031384
8	DRAIN FITTING 3/4"	1200121	A7	SCREW 8-32X1/2" ZNC PH RD F (4X)	5000973
9	DRAIN ELBOW 3/4" FEMALE	1200117	A8	DOOR MOUNT RIGHT	5002657
10	MOTOR AY-62	5000868	--	LEVER (OPTIONAL)	5008351
11	MOTOR MOUNT	5001776			
12	BOLT 1/4-20X5/8" SS HHCS (4X)	0900601			
13	DRAINPAN STD BLACK W/GRID	5011746			
14	GRID STD	5009535			
15	RETAINING PIN (2X)	4140023			
16	SPLASH PANEL STAINLESS STEEL	5010262			
17	CAP MERCH SUPPORT	5010951			
	CAP MERCH SUPPORT W/ LEFT WATER	5011430			
	CAP MERCH SUPPORT W/ RIGHT WATER	5011431			
18	SCREW 8-32X1/2 ZNC PH RD F (4X)	5000973			
19	MERCHANDISER BOTTOM (BLACK)	5010174			
20	MEDALLION ICE FORMED	5012014			
	MEDALLION QUENCH FORMED	5008174			
21	MERCHANDISER TOP (BLACK)	5010175			
22	KEY SWITCH	5000220			
23	TIMER AGITATION 115V NON-ADJUSTABLE	5029024			

* FOR CUSTOMIZED OPTIONS, SUCH AS GRAPHICS, PLEASE CONTACT THE LOCAL SALES REPRESENTATIVE

EXPLODED VIEWS, PARTS & DIAGRAMS

MII-200/250 PARTS LIST

INDEX NUMBER	PARTS DESCRIPTION	PART NUMBER	INDEX NUMBER	PARTS DESCRIPTION	PART NUMBER
1	MUSHROOM BUSHING	0101702	A	WIDE ROCKING CHUTE ASSEMBLY	5008476
2	U-BAR AGITATOR	5009529	A1	DOOR LOCK	5002509
3	U-BAR AGITATOR PIN	5010452	A2	DOOR	5002508
4	PADDLE WHEEL	2601415	A3	MICROSWITCH	1000703
5	PADDLE WHEEL AREA	5001052	A4	DOOR MOUNT LEFT	5002507
6	SCREW 8-32X1/2" KNURL UNSLT (4X)	5000711	A5	WIDE ROCKING CHUTE	5002506
7	BIN LINER	5030665	A6	BRACKET	5031384
8	DRAIN FITTING 3/4"	1200121	A7	SCREW 8-32X1/2" ZNC PH RD F (4X)	5000973
9	DRAIN ELBOW 3/4" FEMALE	1200117	A8	DOOR MOUNT RIGHT	5002657
10	MOTOR AY-62	5000868	--	LEVER (OPTIONAL)	5008351
11	MOTOR MOUNT	5001776			
12	BOLT 1/4-20X5/8" SS HHCS (4X)	0900601			
13	DRAINPAN STD BLACK W/GRID	5011745			
14	GRID STD	5010017			
15	RETAINING PIN (2X)	4140023			
16	SPLASH PANEL STAINLESS STEEL	5028107			
17	CAP MERCH SUPPORT	5010952			
	CAP MERCH SUPPORT W/ LEFT WATER	5011432			
	CAP MERCH SUPPORT W/ RIGHT WATER	5011433			
18	CAP MERCH SUPPORT W/ LEFT & RIGHT WATER	5011958			
19	SCREW 8-32X1/2 ZNC PH RD F (4X)	5000973			
	MERCHANDISER (BLACK) - 200	5010586			
20	MERCHANDISER (BLACK) - 250	5008396			
	MEDALLION ICE - 200	5012002			
	MEDALLION QUENCH - 200	5007045			
	MEDALLION ICE - 250	5012003			
	MEDALLION QUENCH - 250	5007051			
21	MERCHANDISER TOP (BLACK)	NOT USED			
22	KEY SWITCH	5000220			
23	TIMER AGITATION 115V NON-ADJUSTABLE	5029024			

* FOR CUSTOMIZED OPTIONS, SUCH AS GRAPHICS,
PLEASE CONTACT THE LOCAL SALES REPRESENTATIVE

EXPLODED VIEWS, PARTS & DIAGRAMS

MII - 302

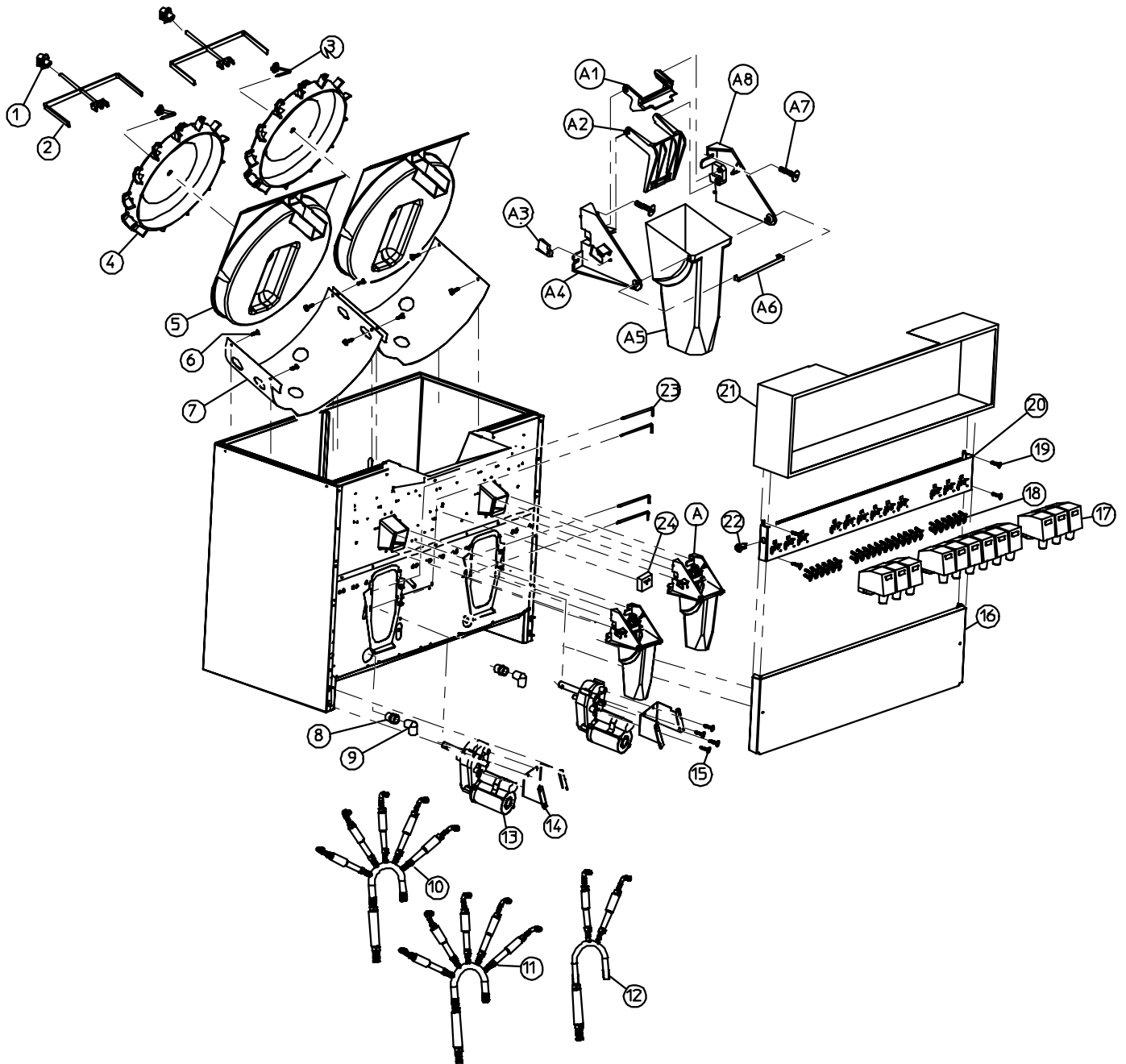

EXPLODED VIEWS, PARTS & DIAGRAMS

MII-302 PARTS LIST

INDEX NUMBER	PARTS DESCRIPTION	PART NUMBER	INDEX NUMBER	PARTS DESCRIPTION	PART NUMBER
1	MUSHROOM BUSHING (2X)	0101702	A	WIDE ROCKING CHUTE ASSEMBLY	5003622
2	U-BAR AGITATOR (2X)	5009529	A1	DOOR LOCK	5002509
3	U-BAR AGITATOR PIN (2X)	5010452	A2	DOOR	5002508
4	PADDLE WHEEL (2X)	2601415	A3	MICROSWITCH	1000703
5	PADDLE WHEEL AREA (2X)	5001051	A4	DOOR MOUNT LEFT	5002507
6	SCREW 8-32X1/2" KNURL UNSLT (4X PER)	5000711	A5	WIDE ROCKING CHUTE	5002506
7	BIN LINER (LEFT)	4220005	A6	BRACKET	5031384
7	BIN LINER (RIGHT)	5030666	A7	SCREW 8-32X1/2" ZNC PH RD F (4X)	5000973
8	DRAIN FITTING 3/4" (2X)	1200121	A8	DOOR MOUNT RIGHT	5002657
9	DRAIN ELBOW 3/4" FEMALE (2X)	1200117	--	LEVER (OPTIONAL)	5002510
10	MANIFOLD # 1,5,6,7,8	5028202			
11	MANIFOLD #2,3,4,10,11	5028203			
12	MANIFOLD #9,12	5028204			
13	MOTOR AY-62 (2X)	5000868			
14	MOTOR MOUNT (2X)	5001776			
15	BOLT 1/4-20X5/8" SS HHCS (4X PER)	0900601			
16	SPLASH PANEL	5011833			
17	VALVES	SEE BOM			
18	SCREW 10-32X1/4 RHMS (4X PER)	5011953			
19	SCREW 8-32X1/2 ZNC PH RD	5000973			
20	VALVE MOUNT CAP 12VALVE	5014099			
21	MERCHANDISER SS W/LID TRAYS	5028235			
22	KEY SWITCH	5000220			
23	RETAINING PIN	4140023			
24	TIMER AGITATION 115V NON-ADJUSTABLE	5029024			

EXPLODED VIEWS, PARTS & DIAGRAMS

MII-150/175/200/250 115V WIRING

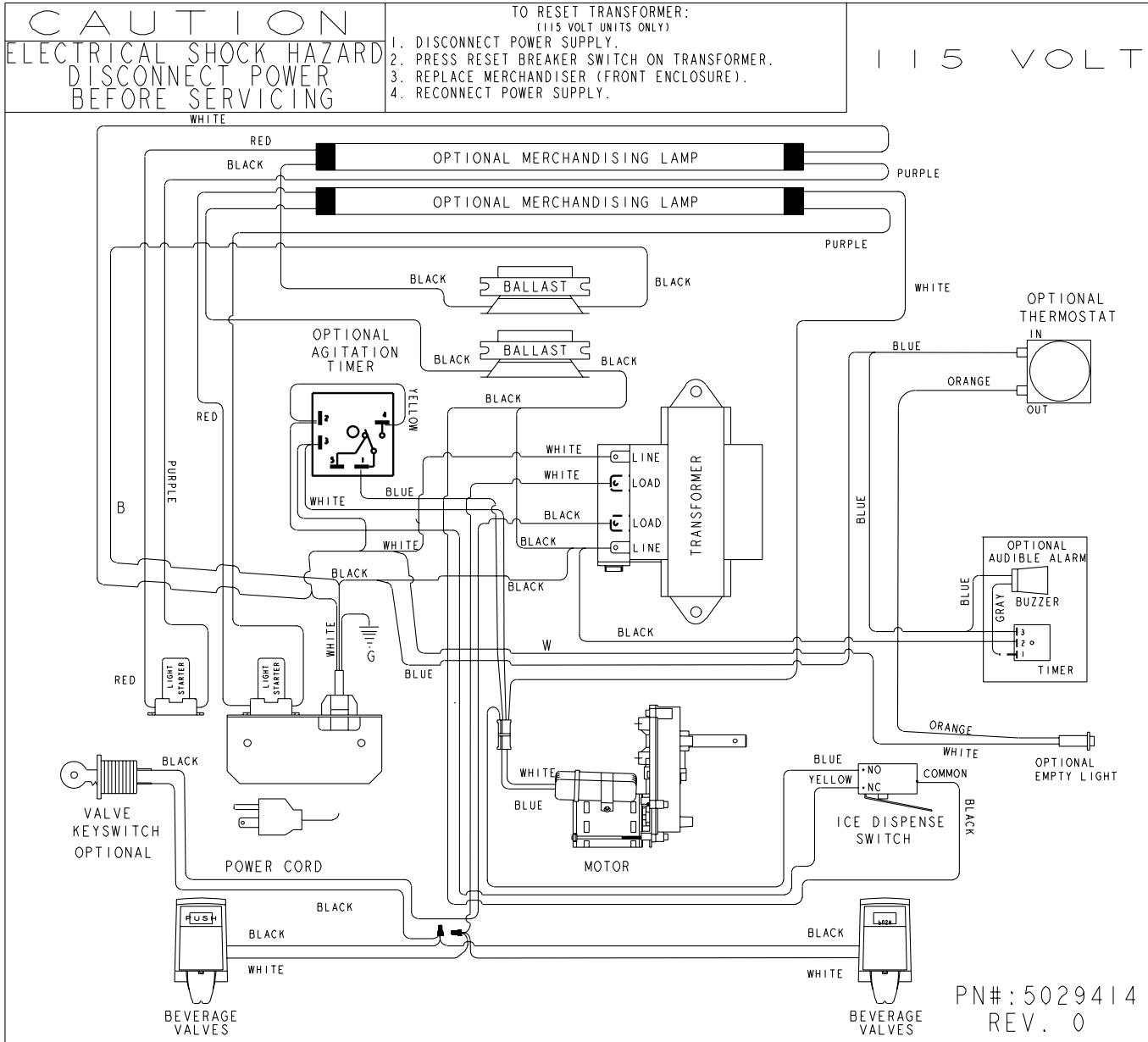

EXPLODED VIEWS, PARTS & DIAGRAMS

MII-302 115V WIRING

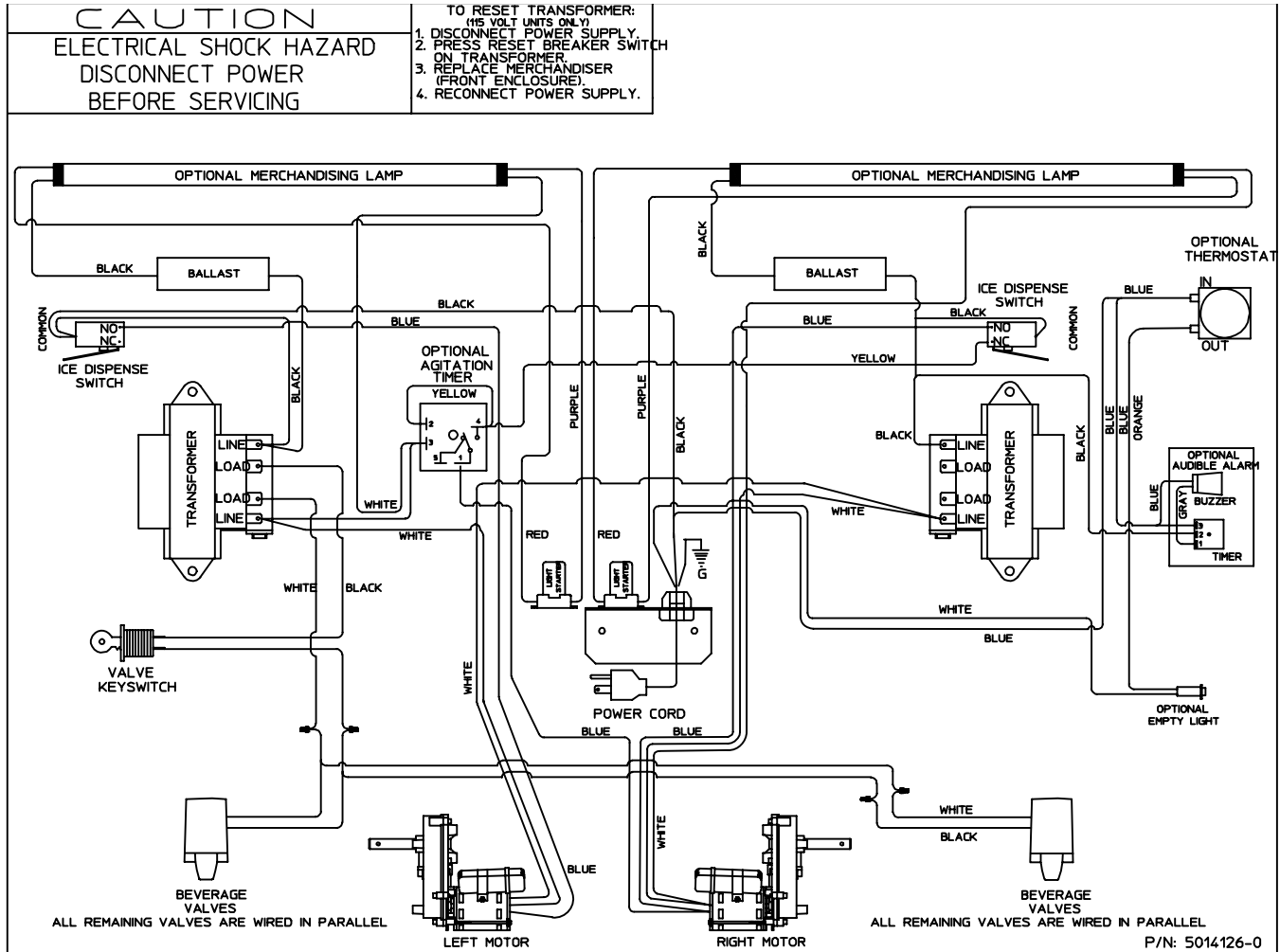

TROUBLESHOOTING

PROBLEM	POSSIBLE CAUSE	CORRECTIVE ACTION
Dispenser will not dispense ice (and NO SOUNDS are heard when machine is activated).	No power.	Check electrical connection.
	Loose wire in electrical system.	Thoroughly check all wire connections.
	Dispenser overloaded with ice.	Remove ice from dispenser until unit will operate.
	Motor not working..	Check thermally protected motor. Replace motor or capacitor if necessary.
Dispenser will not dispense ice (motor runs but no ice movement is heard in bin).	No ice in bin.	Fill dispenser with ice.
	Door not opening.	Check rocking chute mechanism or electric solenoid operation.
	Paddle wheel pin slipped from the paddle wheel.	Replace paddle wheel pin.
Excessive clustering or bridging of ice.	Loaded ice not broken up. (Warning: Super cooled ice is not covered by the Servend warranty.)	Break ice clusters before manually filling the dispenser. (See ice recommendations)
	Excessive water spilling from the ice maker.	Adjust ice maker to eliminate water spillage.
	Poorly adjusted ice maker.	Adjust ice maker to eliminate large waffle shapes.
	Extremely low usage of the dispenser.	Lower the ice level in the bin.
Ice Dispenses continuously.		
	Misaligned microswitch.	Adjust microswitch.
	Agitation timer set incorrectly.	Test agitation timer.
Thumping noise or irregular sound at a particular area of the dispenser.	Shaved ice clusters in the bin.	Remove clusters, discover why ice is shaving, and then repair.

TROUBLESHOOTING

PROBLEM	POSSIBLE CAUSE	CORRECTIVE ACTION
Dispensing crushed ice or reduced dispensing speed.	Water spillage from ice machine into dispenser bin.	Adjust ice maker.
	Agitation timer	Test agitation timer.
	Bridge of ice sheet is too thick.	Adjust ice maker.
	Paddle wheel area broken or cracked.	Replce paddle wheel area.
	Ice clusters in bin.	Break up or remove clusters.
	Door not fully open.	Adjust door.
Door will not close.	Ice jammed in chute.	Adjust bridge in ice maker or, when manually filling, break up clusters.
	Door and/or door lock has come out of place.	Replace door and lock into proper position.
Mounting brackets for rocking chute have spread too far apart.		Bend parts into shape.

DO NOT USE

***Under
Preventative
Maintenance***

Please post this page in front of dispenser when cleaning system.



INDEX

B

brixing 3

C

Carbon Dioxide 6
CAUTION 18, 19, 25
claims 13
Cleaning 3
CO2 7
CO2 monitors 7
cube ice 13

D

damage 3, 13
delivery 3, 13
Diagrams
26, 27, 28, 29, 30, 31, 32
Dispensing 13
dispensing valves 24
Distributor 3
distributor 3

E

exterior 24

F

FOREWORD 3

H

health department 24

I

Ice 13
Ice Storage 13
INSPECTION 3
inspection 13
INSTALLATION 9, 10, 11, 12
Installation Date 3
Instructions 24
irregularities 3

M

MBE 3
Model Number 3
modifications 6
Monthly Cleaning 25

O

Operation 6

Q

Qualified Service Personnel 6

R

regulations 24
Relocation 6
return procedures 3
RGA 3

S

SAFETY 6, 7
sanitizing 7
Serial Number 3
Service Agent 3
service assistance 3
Service Personnel 6
Shipping 6
Shipping, Storage, Relocation 6
soapy water 25
solvents 25
start-up 6
Storage 6

T

Telephone Number 3

U

Unit Inspection 13
UNPACKING 3

W

Warning 6
WARRANTY 3
WARRANTY INFORMATION 3



Manitowoc Beverage Equipment

2100 Future Drive w Sellersburg, IN 47172-1868
Tel: 812.246.7000, 800.367.4233 • Fax: 812.246.9922
www.manitowocbeverage.com

In accordance with our policy of continuous product development and improvement, this information is subject to change at any time without notice.