



**MULTIPLY<sup>®</sup>**



# **S250M 8 & 10 Valve Beverage/Ice Dispenser with Flex Manifold**

## **Installation, Use & Care Manual**

This manual is updated as new information and models are released.  
Visit our website for the latest manual. [www.multiplexbeverage.com](http://www.multiplexbeverage.com)

*Leader in Ice & Beverage Dispensers*

Part Number [020002115](#) 10/11

## Safety Notices

As you work on Multiplex equipment, be sure to pay close attention to the safety notices in this manual. Disregarding the notices may lead to serious injury and/or damage to the equipment.

Throughout this manual, you will see the following types of safety notices:

### **Warning**

Text in a Warning box alerts you to a potential personal injury situation. Be sure to read the Warning statement before proceeding, and work carefully.

### **Caution**

Text in a Caution box alerts you to a situation in which you could damage the equipment. Be sure to read the Caution statement before proceeding, and work carefully.

## Procedural Notices

As you work on Multiplex equipment, be sure to read the procedural notices in this manual. These notices supply helpful information which may assist you as you work.

Throughout this manual, you will see the following types of procedural notices:

### **Important**

Text in an Important box provides you with information that may help you perform a procedure more efficiently. Disregarding this information will not cause damage or injury, but it may slow you down as you work.

NOTE: Text set off as a Note provides you with simple, but useful, extra information about the procedure you are performing.

## Read These Before Proceeding:

### **Caution**

Proper installation, care and maintenance are essential for maximum performance and trouble-free operation of your Multiplex equipment. Read and understand this manual. It contains valuable care and maintenance information. If you encounter problems not covered by this manual, do not proceed, contact Multiplex. We will be happy to provide assistance.

### **Important**

Routine adjustments and maintenance procedures outlined in this manual are not covered by the warranty.

### **Warning**

#### **PERSONAL INJURY POTENTIAL**

Do not operate equipment that has been misused, abused, neglected, damaged, or altered/modified from that of original manufactured specifications.

**NOTE: SAVE THESE INSTRUCTIONS.**

We reserve the right to make product improvements at any time. Specifications and design are subject to change without notice.

# Table of Contents

---

## Section 1

### General Information

|   |     |
|---|-----|
| <b>Read This Manual</b> .....                     | 1-1 |
| <b>Unit Inspection</b> .....                      | 1-1 |
| <b>Model Numbers</b> .....                        | 1-1 |
| <b>Accessories</b> .....                          | 1-1 |
| Baffle for Manitowoc® Cubers .....                | 1-1 |
| Manual Fill Lid for Dispensers with a Cuber ..... | 1-1 |
| Ice Flow Restrictor .....                         | 1-2 |
| Legs .....  | 1-2 |
| <b>Serial Number Location</b> .....               | 1-2 |
| <b>Warranty Information</b> .....                 | 1-2 |

## Section 2

### Installation Instructions

|   |     |
|---|-----|
| <b>General System Overview</b> .....                            | 2-1 |
| <b>Pre-installation Checklist</b> .....                         | 2-2 |
| B-I-B System also: .....  | 2-2 |
| Post Mix System: .....  | 2-2 |
| Bulk Syrup System also: .....                                   | 2-2 |
| Double Check: .....   | 2-2 |
| Also consider: .....  | 2-2 |
| Additional Checks for Top Mounted Ice Maker Installations ..... | 2-3 |
| <b>Dimensions</b> .....   | 2-4 |
| <b>Footprint</b> .....  | 2-4 |
| <b>Location</b> .....   | 2-5 |
| <b>Grounding Instructions</b> .....                             | 2-5 |
| <b>Unit Installation</b> .....                                  | 2-6 |
| <b>Installing Baffle for Ice Machine Installations</b> .....    | 2-6 |
| “S” Series Baffle .....   | 2-6 |
| “Q” Series Baffle .....   | 2-6 |
| <b>Water and Syrup Lines</b> .....                              | 2-7 |
| Carbonated Water Lines .....                                    | 2-7 |
| Plain Water Lines .....   | 2-7 |
| Syrup Lines .....   | 2-7 |
| <b>Drainage Options</b> .....                                   | 2-7 |
| <b>Plumbing Diagrams</b> .....                                  | 2-8 |
| S250M 8 Valve .....   | 2-8 |
| S250M 10 Valve .....  | 2-9 |

## Table of Contents (continued)

---

### Section 3 Operation

|                                       |            |
|---------------------------------------|------------|
| <b>Component Identification</b> ..... | <b>3-1</b> |
| <b>Sequence of Operation</b> .....    | <b>3-2</b> |
| Ice Recommended for Dispensing .....  | <b>3-2</b> |
| Ice Storage and Dispensing .....      | <b>3-2</b> |
| Beverage Valves .....                 | <b>3-2</b> |
| Rocking Chute Ice Dispensing .....    | <b>3-2</b> |
| Carbonation .....                     | <b>3-2</b> |
| Syrup Delivery System .....           | <b>3-3</b> |
| Racking .....                         | <b>3-3</b> |
| B-I-B .....                           | <b>3-3</b> |
| Pumps .....                           | <b>3-3</b> |
| Auto Bag Selectors .....              | <b>3-3</b> |
| Agitation Timer .....                 | <b>3-3</b> |
| Operation Checks & Adjustments .....  | <b>3-4</b> |

### Section 4 Maintenance

|   |            |
|---|------------|
| <b>Cleaning</b> .....                         | <b>4-1</b> |
| Daily Cleaning .....                          | <b>4-1</b> |
| Monthly Cleaning .....                        | <b>4-2</b> |
| <b>Disassembly</b> .....                      | <b>4-3</b> |
| Disassembly for Cleaning & Maintenance .....  | <b>4-3</b> |
| Removal of Gear Motor .....                   | <b>4-4</b> |
| <b>Sanitizing</b> .....                       | <b>4-5</b> |
| Beverage System Cleaning .....                | <b>4-5</b> |
| Bag-In-Box System Sanitation .....            | <b>4-5</b> |
| <b>Preventive Maintenance</b> .....           | <b>4-6</b> |
| <b>Shipping, Storage and Relocation</b> ..... | <b>4-6</b> |

### Section 5 Before Calling for Service

|                        |            |
|------------------------|------------|
| <b>Checklist</b> ..... | <b>5-1</b> |
|------------------------|------------|

# Section 1

## General Information

---

### Read This Manual

Multiplex Beverage developed this manual as a reference guide for the owner/operator and installer of this equipment. Please read this manual before installation or operation of the machine. A qualified service technician must perform installation and start-up of this equipment, consult **Section 5** within this manual for service assistance.

If you cannot correct the service problem, call your Multiplex Service Agent or Distributor. Always have your model and serial number available when you call.

Your Service Agent \_\_\_\_\_

Service Agent Telephone Number \_\_\_\_\_

Your Local Multiplex Distributor \_\_\_\_\_

Distributor Telephone Number \_\_\_\_\_

Model Number \_\_\_\_\_

Serial Number \_\_\_\_\_

Installation Date \_\_\_\_\_

### Unit Inspection

Thoroughly inspect the unit upon delivery. Immediately report any damage that occurred during transportation to the delivery carrier. Request a written inspection report from a claims inspector to document any necessary claim.



#### **Warning**

#### **PERSONAL INJURY POTENTIAL**

Do not operate equipment that has been misused, abused, neglected, damaged, or altered/modified from that of original manufactured specifications.

### Model Numbers

This manual covers the following model:

|                               |
|-------------------------------|
| <b>Beverage/Ice Dispenser</b> |
| S250M                         |

### Accessories

#### **BAFFLE FOR MANITOWOC® CUBERS**

When installing a Manitowoc Ice Machine on a dispenser, a baffle kit is required for proper installation. The baffle kit is designed to prevent ice from lying against the front of the ice machine, and melting down the front of the dispenser. There are two different baffle kits available for "S" series ice machines, one kit is for the 30" wide machine, and the other kit is for the 22" wide machine. There is also a kit for "Q" series ice machines.

Kits are available through your local distributor. List prices may be subject to change without notification. Please call your local parts distributor for current pricing before ordering.

#### **MANUAL FILL LID FOR DISPENSERS WITH A CUBER**

If you are top mounting your dispenser with a cuber, you will require a lid for the manual fill area at the top, front of the dispenser.

If you ordered a dispenser and a cuber at the same time, the manual fill lid was included with the unit. The manual fill lid can be ordered from your local distributor.

## ICE FLOW RESTRICTOR

An optional ice flow restrictor decreases the amount of ice allowed to enter the ice chute by blocking a small area at the entrance of the dispenser chute. This in turn restricts the flow of ice that is dispensed into your cup.

Please refer to the instructions included in kit #5013822 for more information on how to install.



**Ice Flow Restrictor**

NOTE: For full information about icemaker installation, including plumbing lines connections and electrical requirements, see the icemaker installation manual.

## LEGS

Legs are optional equipment with most MBE dispensers. Standard legs are four-inch (10.2 cm) tall stainless steel legs. It is recommended if an icemaker is installed on top of the dispenser, legs must not be installed. When installing legs on a dispenser, leg braces must be used. These are metal braces fitting side to side under the dispenser that reinforce the leg attachment area.

## Serial Number Location

This number is required when requesting information from your local distributor. The serial number is listed on the SERIAL NUMBER DECAL affixed to the dispenser.

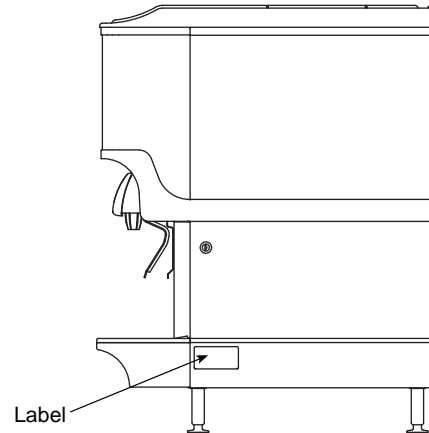

**Serial Number Location**

## Warranty Information

Consult your local MBE Distributor for terms and conditions of your warranty. Your warranty specifically excludes all beverage valve brixing, general adjustments, cleaning, accessories and related servicing.

Your warranty card must be returned to MBE to activate the warranty on this equipment. If a warranty card is not returned, the warranty period can begin when the equipment leaves the MBE factory.

No equipment may be returned to MBE without a written Return Materials Authorization (RMA). Equipment returned without an RMA will be refused at MBE's dock and returned to the sender at the sender's expense.

Please contact your local MBE distributor for return procedures.

# Section 2

## Installation Instructions

### General System Overview

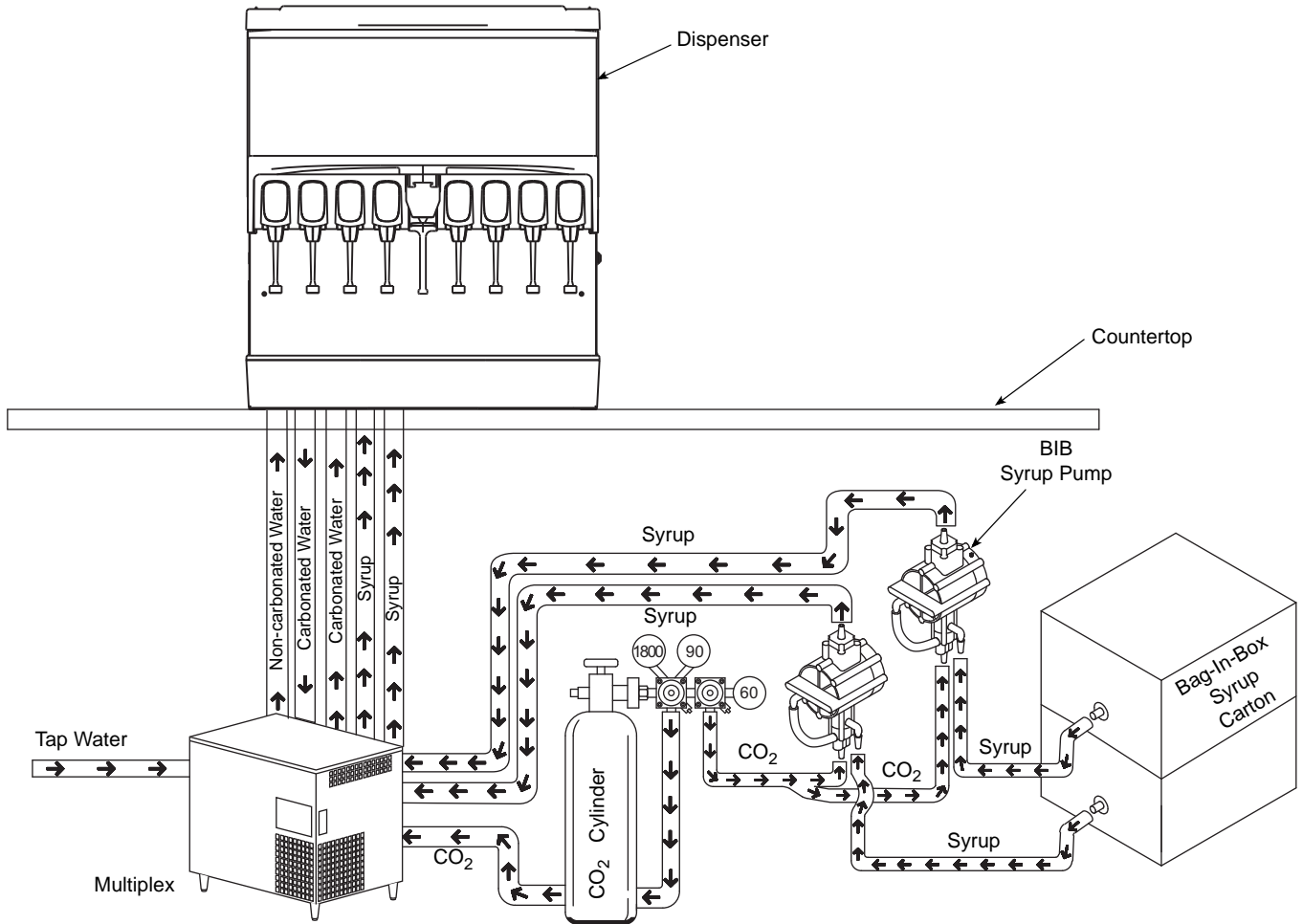

**Typical S Series Beverage Dispensing System  
with Valves and Flex Manifolds**

**Pre-installation Checklist**

When installing any system, first make sure the major components are available. Generally the major components necessary for an installation are:

**B-I-B SYSTEM ALSO:**

- B-I-B connectors
- B-I-B regulator set
- B-I-B rack
- B-I-B syrup boxes

**POST MIX SYSTEM:**

- CO<sub>2</sub> regulator set
- Beverage dispenser
- Beverage tubing
- CO<sub>2</sub> tank
- Carbonator
- Stepless (Oetiker) clamps
- Chain for CO<sub>2</sub> tank

**BULK SYRUP SYSTEM ALSO:**

- Syrup connectors for Bulk tank
- Gas connectors for Bulk tank
- Bulk syrup tanks

**DOUBLE CHECK:**

- Do you have enough space to install the dispenser or a dispenser and top mounted cuber?
- Does top mounted cuber (if utilized) have a minimum of 6 inches (15.3 cm) clearance on all sides?
- Is the countertop level?
- Can the countertop support the weight of the dispenser, or the dispenser/cuber combination plus the weight of the stored ice?

**ALSO CONSIDER:**

- Water line
- Drain
- Power outlet
- Heating and air conditioning ducts

**ADDITIONAL CHECKS FOR TOP MOUNTED ICE MAKER INSTALLATIONS**

**Location** — Avoid placing the dispenser and/or ice machine near heat sources such as radiators, ovens, refrigeration equipment and direct sunlight.

**Clearances** — Six inch (15.2 cm) clearance on all sides of the icemaker is needed.

**Front of icemaker to be flush with front of dispenser** — The front of the icemaker must be flush with the front of the dispenser. When the icemaker is flush with the front of the dispenser, some icemakers may overhang at the back of the dispenser.

**Drains** — A separate drain line is required for the ice machine, in addition to a drain line for the ice/beverage dispenser.

Dispensers require an adapter kit to install some top-mounted icemakers. Contact your local distributor for the correct adapter kit.

Dimensions

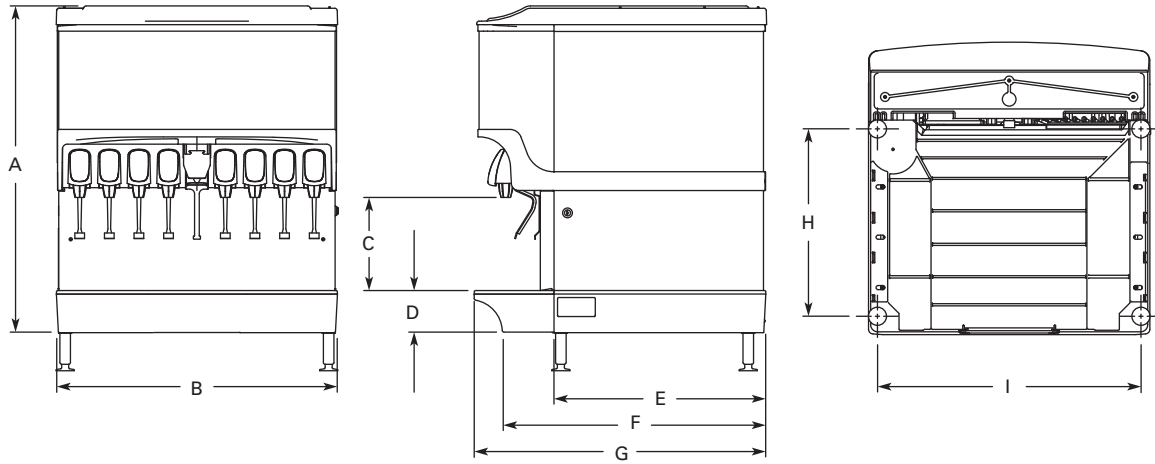

| A                    | B                   | C                  | D                  | E                   | F                   | G                   | H                   | I                   |
|----------------------|---------------------|--------------------|--------------------|---------------------|---------------------|---------------------|---------------------|---------------------|
| 39.81"<br>(101.1 cm) | 30.00"<br>(76.2 cm) | 9.94"<br>(25.2 cm) | 4.44"<br>(11.3 cm) | 22.63"<br>(57.5 cm) | 28.00"<br>(71.1 cm) | 31.13"<br>(79.1 cm) | 20.00"<br>(50.8 cm) | 27.44"<br>(69.7 cm) |

Footprint

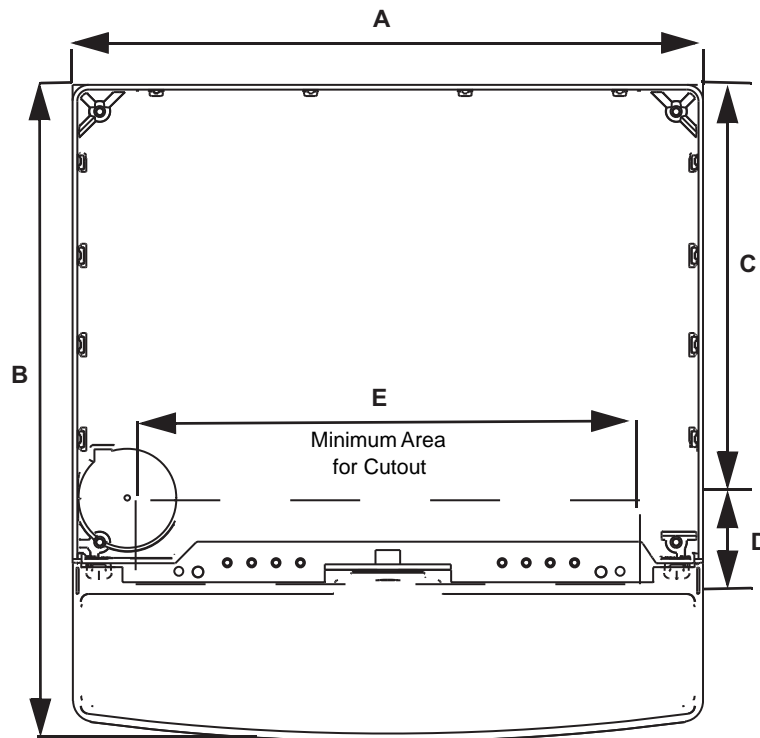

| A                    | B                    | C                    | D                   | E                    |
|----------------------|----------------------|----------------------|---------------------|----------------------|
| 30.00"<br>(76.20 cm) | 31.13"<br>(79.07 cm) | 19.81"<br>(50.32 cm) | 4.00"<br>(10.16 cm) | 24.00"<br>(61.00 cm) |

## Location

Avoid placing the dispenser near heat sources such as radiators, ovens, refrigeration equipment and direct sunlight.

### Warning

Carbon Dioxide (CO<sub>2</sub>) displaces oxygen. Exposure to a high concentration of CO<sub>2</sub> gas causes tremors, which are followed rapidly by loss of consciousness and suffocation. If a CO<sub>2</sub> gas leak is suspected, particularly in a small area, immediately ventilate the area before repairing the leak. CO<sub>2</sub> lines and pumps should not be installed in an enclosed space. An enclosed space can be a cooler or small room or closet. This may include convenience stores with glass door self serve coolers. If you suspect CO<sub>2</sub> may build up in an area, venting of the B-I-B pumps and / or CO<sub>2</sub> monitors should be utilized.

## Grounding Instructions

### Warning

Risk of electrical shock. Connect to a properly grounded outlet only.

This appliance must be grounded. In the event of malfunction or breakdown, grounding provides a path of least resistance for electric current to reduce the risk of electric shock. This appliance is equipped with a cord having an equipment-grounding conductor and a grounding plug. The plug must be plugged into an appropriate outlet that is properly installed and grounded in accordance with all local codes and ordinances.

### Warning

Improper connection of the equipment-grounding conductor can result in a risk of electric shock. The conductor with insulation having an outer surface that is green with or without yellow stripes is the equipment grounding conductor. If repair or replacement of the cord or plug is necessary, do not connect the equipment-grounding conductor to a live terminal. Check with a qualified electrician or serviceman if the grounding instructions are not completely understood, or if in doubt as to whether the appliance is properly grounded. Do not modify the plug provided with the appliance — if it will not fit the outlet, have a proper outlet installed by a qualified electrician.

### Warning

When using electric appliances, basic precautions should always be followed, including the following:

- a. Read all the instructions before using the appliance.
- b. To reduce the risk of injury, close supervision is necessary when an appliance is used near children.
- c. Do not contact moving parts.
- d. Only use attachments recommended or sold by the manufacturer.
- e. Do not use outdoors.
- f. For a cord-connected appliance, the following shall be included:
  - Do not unplug by pulling on cord. To unplug, grasp the plug, not the cord.
  - Unplug from outlet when not in use and before servicing or cleaning.
  - Do not operate any appliance with a damaged cord or plug, or after the appliance malfunctions or is dropped or damaged in any manner. Contact the nearest authorized service facility for examination, repair, or electrical or mechanical adjustment.
- g. For a permanently connected appliance — Turn the power switch to the off position when the appliance is not in use and before servicing or cleaning.
- h. For an appliance with a replaceable lamp — always unplug before replacing the lamp. Replace the bulb with the same type.
- i. For a grounded appliance — Connect to a properly grounded outlet only. See Grounding Instructions.

**Unit Installation**

1. Place the dispenser in the desired location.
2. Run the beverage lines and water lines (make sure to install the water connections to the proper inlets). *(Refer to plumbing diagrams)*
3. Install drain plumbing and insulate. *(See Drainage Options)*
4. Set flexible manifold for correct drink settings.
5. Fill bin with ice.
6. Connect power supply.
7. Brix beverage valves.
8. Meet all code requirements.

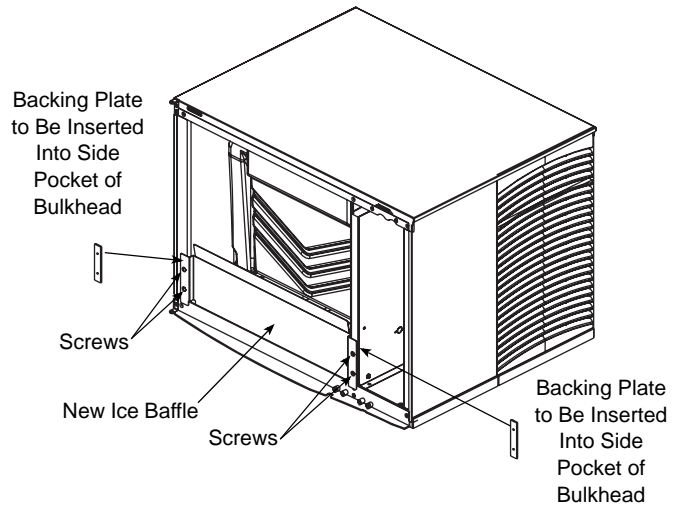

**“S” Series Ice Machine**

**Installing Baffle for Ice Machine Installations**

**“S” SERIES BAFFLE**

1. Remove both front panels.
2. Examine the ice machine to see if the machine has four screws on the lower front plastic panels.
3. If there are screws, remove them from the countersunk holes on the front surface of the machine, save the screws.
4. Install the deflector, using the four screws removed in step three.
5. Four screws and two backing plates are in the kit.
6. If there are no screws on the ice machine (step 2), pierce the thin plastic countersunk holes, install the backing plates and install the deflector using the screws from the kit.
7. Replace the front panels.

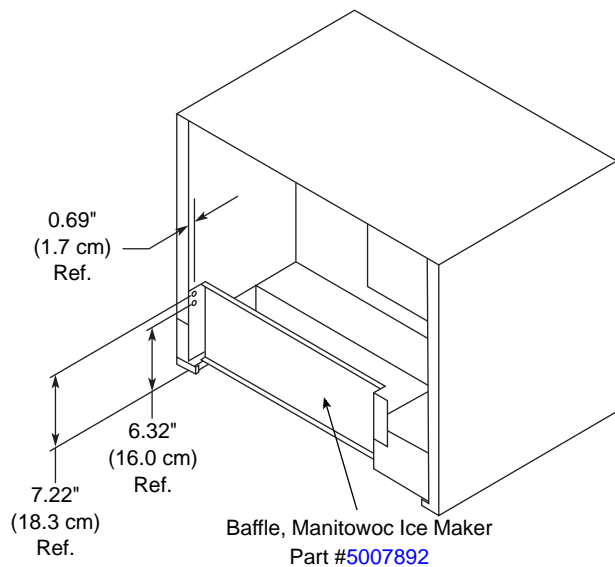

**“Q” Series Ice Machine**

**“Q” SERIES BAFFLE**

1. Position baffle on top of water well with tab on the front and the other tab inside the water well.
2. Mount the baffle on the left side of the ice maker using the hole and screw provided.

**Water and Syrup Lines**

**CARBONATED WATER LINES**

- Unit requires connection of two (2) carb water lines, (1/2" barb) one for each flex manifold and also completes the carbonated water system.
- Strip back the insulation on the conduit and route through the hole in counter top. Directly connect the lines to the left and right manifolds.

**PLAIN WATER LINES**

- Unit requires connection of two (2) plain water lines, one for each flex manifold. 3/8" barb on end of check valve (required for code). Use parts from installation kit (2x2" black stripped 3/8" tube and 3/8" x 1/2" barb adapter)
- Strip back the insulation on the conduit and route through the hole in counter top. Directly connect the lines to the left and right manifolds.

**SYRUP LINES**

- The eight (8) valve unit has eight (8) syrup lines, Four (4) for the left manifold and four (4) for the right manifold. The ten (10) valve unit has ten (10) syrup lines, five (5) on the left and five (5) on the right. All 3/8" barb fittings. For 1/2" conduit syrup tubes (up to three (3)) use parts from the installation kit. (3"x2" orange, green, white stripped 3/8" tubes and 3/8" barb adapters) to connect 3/8" barb to 1/2" syrup conduit tubes.
- Strip back the insulation on the conduit and route through the hole in counter top. Directly connect the lines to the left and right manifolds.
- FULLY INSULATE (no air gaps) and finish with tape wrap, all tubing from the flex manifolds to the conduit bundle insulation. All tubing must be insulated and air tight.

**Drainage Options**

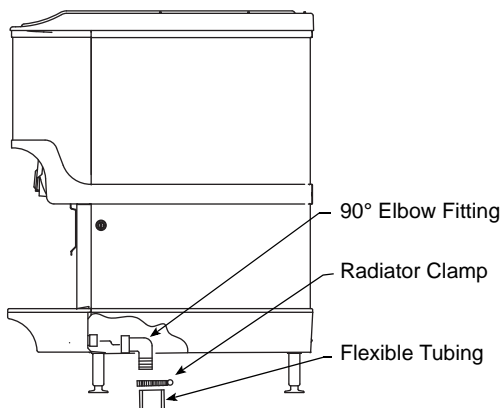

**Drainage Through Bottom**

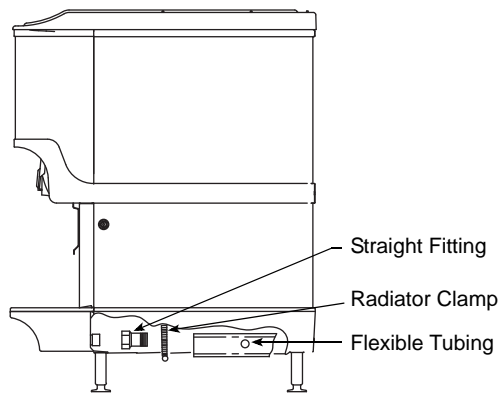

**Drainage Through Back**

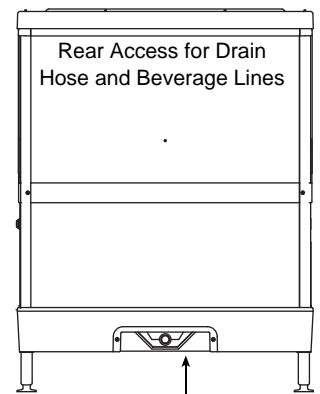

**Rear View**

Plumbing Diagrams

S250M 8 VALVE

Servend Recommended Plumbing

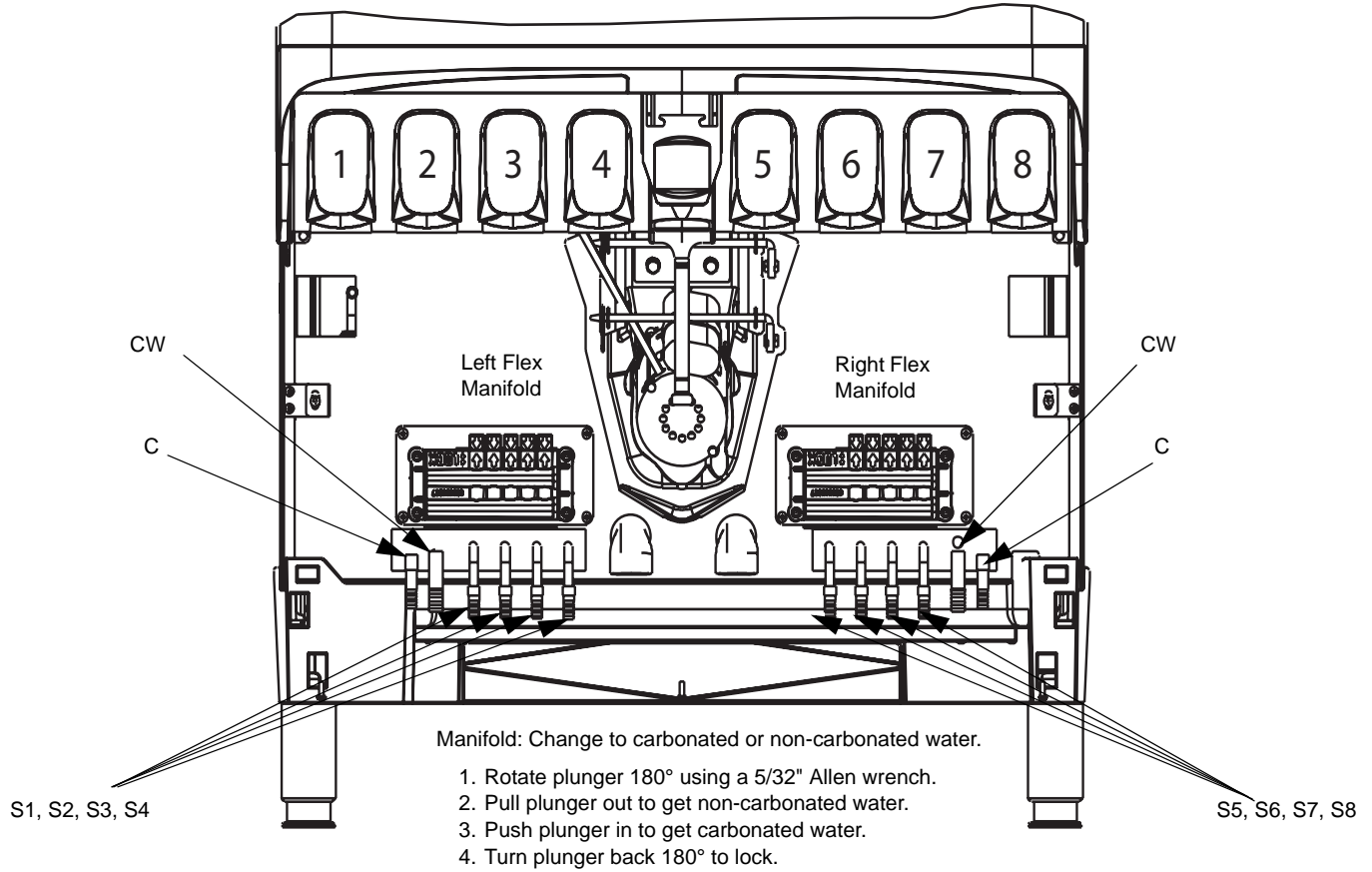

S250M 10 VALVE

Servend Recommended Plumbing

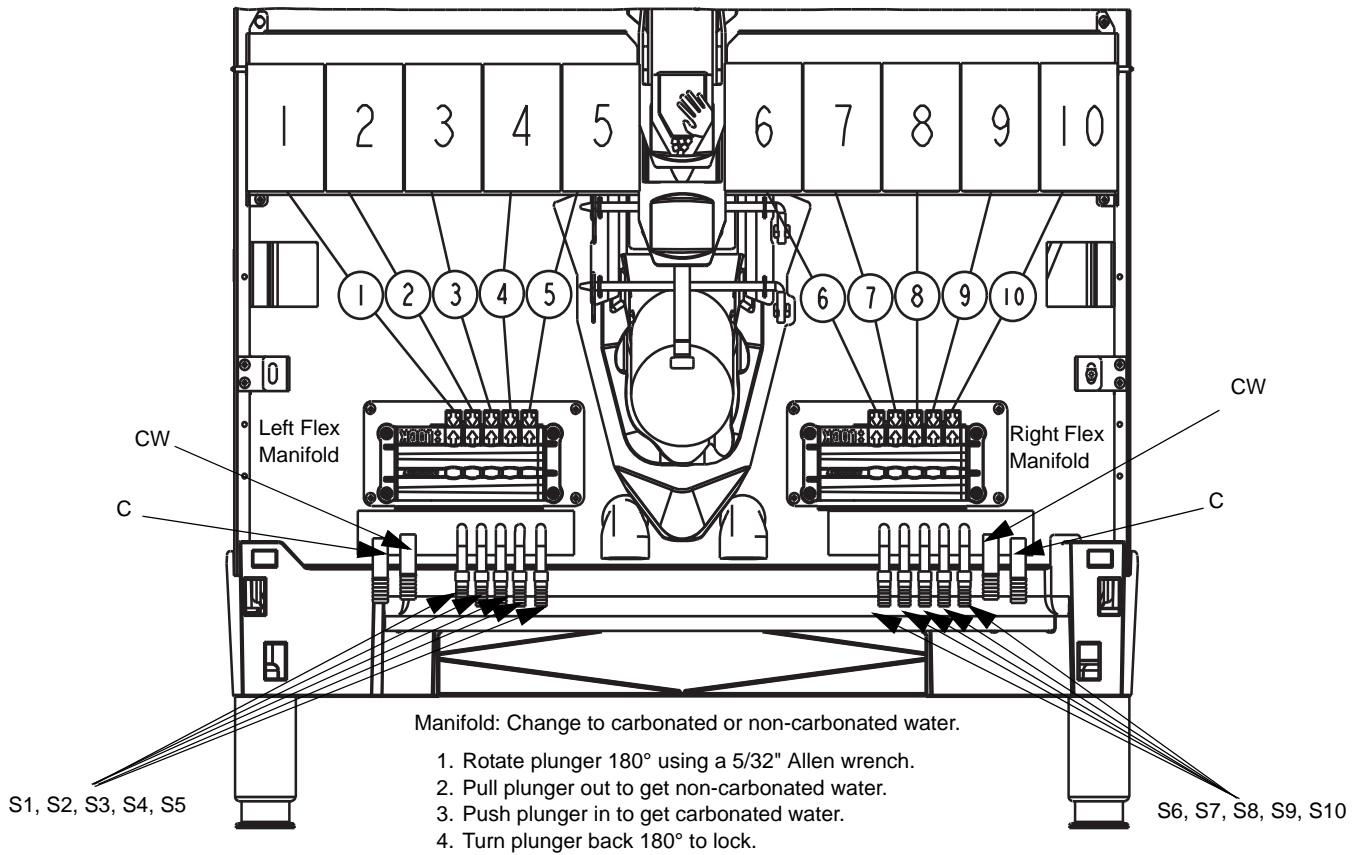

THIS PAGE INTENTIONALLY LEFT BLANK

# Section 3 Operation

---

## Component Identification

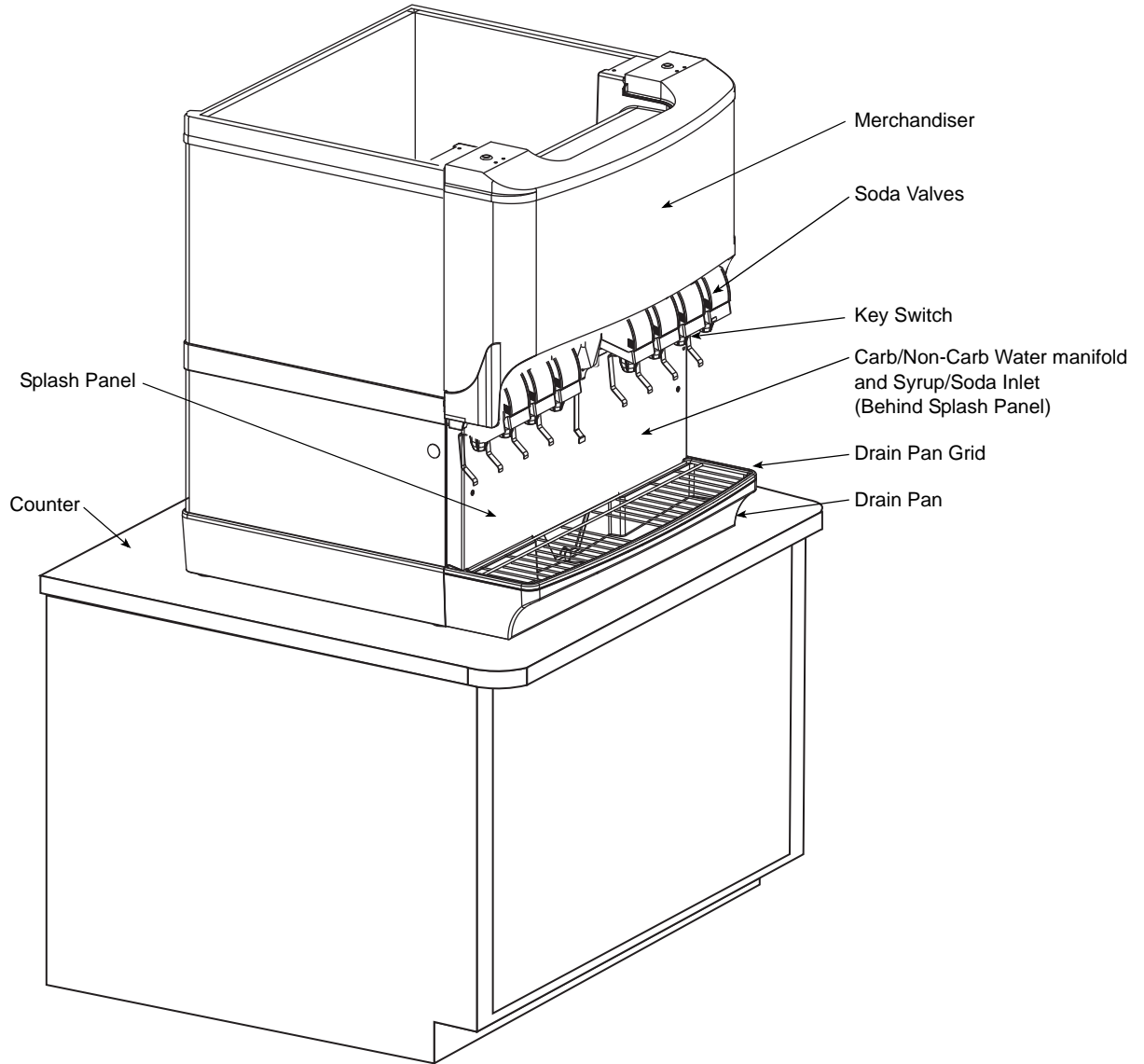

Sequence of Operation

ICE RECOMMENDED FOR DISPENSING

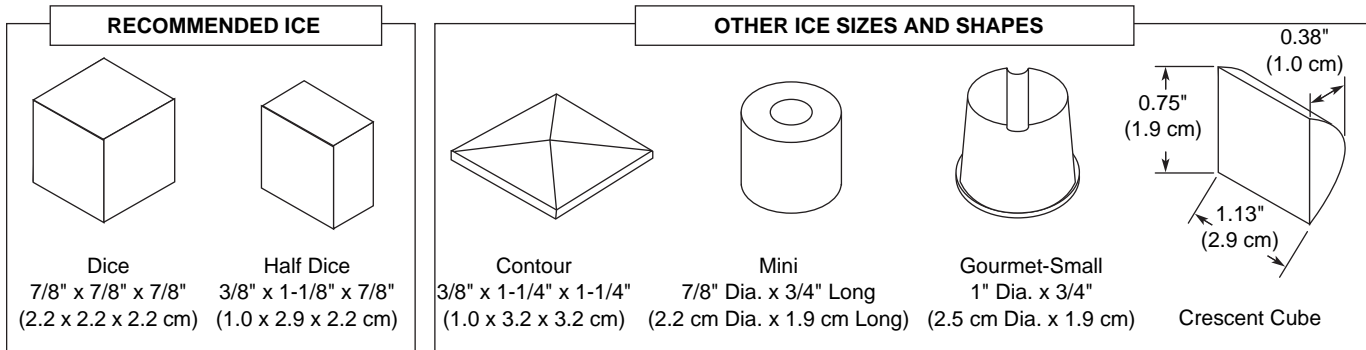

Dispensers are designed to dispense hard, cube ice up to one-inch square. The ice shapes and sizes listed above are recommended for dispensing. Warm “Super Cooled” Ice Before Dispensing: “Super Cooled” ice is not recommended for dispensing. “Super cooled” ice is ice that has been stored in freezers below 32°F. Should it be necessary to temporarily use “super cooled” ice, allow the ice to warm at room temperature for 25 to 30 minutes before placing the ice in the dispenser.

ICE STORAGE AND DISPENSING

As the customer presses the rocking chute, the arm at the top left rear of the chute pushes upward on the door lock. The door opens until it contacts the stops in the mounting brackets. The plastic arm on the ice chute also activates the lever of the ice dispensing switch. When activated, the micro switch starts the gear motor. The gear motor turns the paddle wheel and agitator arm.

The paddle wheel carries ice. Periodic agitation is standard on the 30" and larger dispensers. During periodic agitation, the paddle wheel and agitator turn for approximately three seconds every three and one half-hours. The door lock prevents ice from being dispensed during the agitation cycle.

BEVERAGE VALVES

Post-mix beverage valves are designed to precisely meter the flow of both water and syrup to obtain the proper mixing ratio. The syrup and soda water components of the post-mix beverage are mixed as they leave the beverage valve.

ROCKING CHUTE ICE DISPENSING

As the customer presses the rocking chute, the arm at the top left rear of the chute pushes upward on the door lock. The door opens until it contacts the stops in the mounting brackets. The plastic arm on the ice chute also activates the lever of the ice dispensing switch. When activated, the micro switch starts the gear motor. The gear motor turns the paddle wheel and agitator bar.

CARBONATION

The purpose of the carbonator is to take regular tap water at street water pressure (minimum 20 PSI, maximum 80 PSI, dynamic or flowing pressure) 1/2" water line and increase the water to beverage system pressure (usually 100 PSI). This water is then combined with the CO<sub>2</sub> gas. Because the water and gas are at the same pressure, the CO<sub>2</sub> will dissolve into the water. Chilling the mixture before dispensing will assist in locking the carbon dioxide into the water. After dispensing, the CO<sub>2</sub> may be unlocked from the liquid. The CO<sub>2</sub> will gradually leave the liquid due to pressure and temperature changes.

Components

The components of the carbonator are: water pump, an electric motor to operate the pump, carbonator tank where the water and CO<sub>2</sub> mix, and a water level control.

### Operation

Carbon Dioxide (CO<sub>2</sub>) leaves the storage tank and arrives at the carbonator tank through the gas inlet. Water supply enters the carbonator pump inlet at regular street water line pressure (minimum 20 PSI, maximum 80 PSI, dynamic or flowing pressure). The water pump increases the pressure of the water, which allows the water to flow into the carbonator tank. The CO<sub>2</sub> and the water mix together in the carbonator to produce the carbonated water that is then sent to the soda dispenser.

The agitation of the water and CO<sub>2</sub> together in the tank under high pressure creates the soda water. The quality of carbonation (percent of CO<sub>2</sub> mixed in the water) increases as the water temperature decreases and exposure time increases.

The water level in the carbonator tank is controlled by a water level control in the tank. This control turns the pump motor off and on to maintain a preset level of liquid in the tank. The water level control may be electronic probes or a mechanical float.

### SYRUP DELIVERY SYSTEM

Your syrup location can vary depending on the volume of beverages served and ease of accessibility. Your beverage system may set in a back storage room or under the counter of the dispenser. Configurations are almost limitless. Check the temperatures expected for the storage location. Adverse temperatures can affect the storage and quality of beverage products. It is recommended the temperature of storage location should not fall below 40°F or rise above 90°F.

### RACKING

Regardless if you are working on a B-I-B or Figal system, a place will be designated for placement of the product. A rack (or shelf) system affords systematic placement and complete usage of the beverage paid for. The B-I-B rack allows the boxes to lay properly for syrup dispersal. Please check with your B-I-B syrup supplier. Some boxes must be slightly tilted down, while others may be in virtually any position. The Figal tank rack keeps the newer and full tanks organized at one end of the beverage line with the partial tanks at the other.

### B-I-B

The Bag-In-Box system refers to a plastic disposable bag. The B-I-B normally contains 5 gallons of syrup, however some locations offer 2-1/2 gallon B-I-B units. This plastic bag is then held inside a cardboard or other container. B-I-B systems are for post-mix applications only.

### PUMPS

The syrup in a B-I-B system is delivered to the beverage system through gas operated pumps. These pumps extract the syrup out of the bags, forcing the syrup throughout the system.

### AUTO BAG SELECTORS

These are used on higher volume B-I-B systems where two or more bags of the same product are connected to one pump and one system. An auto bag selector is essentially a valve that automatically changes from one bag (or series of bags) to another bag (or series of bags) of syrup as the bags empty, allowing a constant flow of product.

### AGITATION TIMER

The timer is non-adjustable and is set to agitate the ice for 3 seconds every 3.5 hours. Activating the dispenser will reset the timer. After 3.5 hours of non-use, the timer will energize the dispenser motor.

The LED tells the technician in which mode the timer is operating. Rather than a jumper pin, this timer has a female spade connector that must be connected to terminal number 6.

When this jumper is in place, the LED will blink at one-second intervals, this is the run mode.

When the jumper is open, the LED will flash every 0.4 second. This is the test mode and the timer will cycle every 55 seconds in test mode. If the timer is left in test mode, it will automatically reset to run mode.

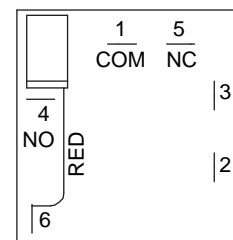

### Operation Checks & Adjustments

#### Rocking Chute Ice Delivery Switch Adjustment

To properly adjust the switch, first unplug the power cord to the unit then remove the merchandiser. This will give you access to the ice delivery switch located on the left side of the rocking chute.

The left side of the rocking chute has a tab that pushes up on the ice delivery switch. To adjust it, use needle nose pliers and bend the arm of the switch up or down in order to change the point where the tab makes contact with the switch arm.

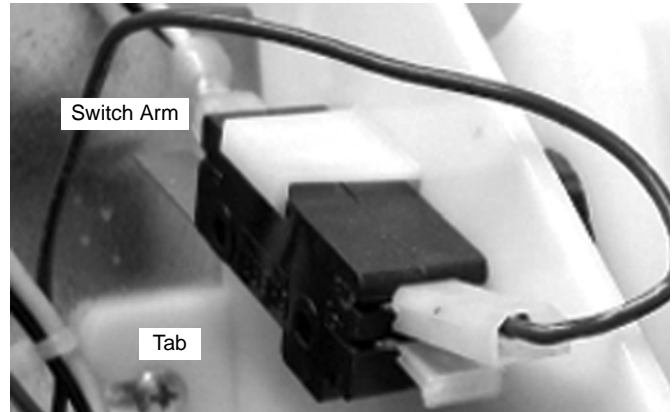
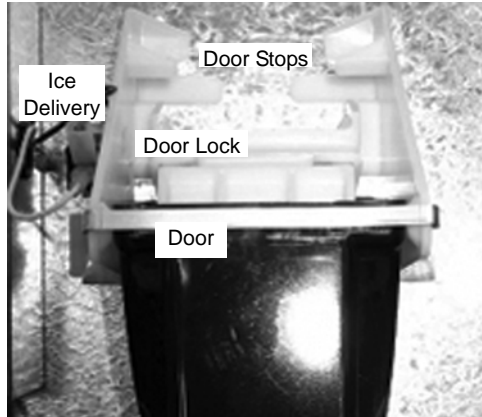

Begin by observing the chute by slowly pushing against the rocking chute. When the ice delivery switch clicks, measure the distance from the door stops on the rocking chute bracket to the door. The distance between the two must be no more than 1/4" (0.64 cm), but no less than 1/16" (0.16 cm).

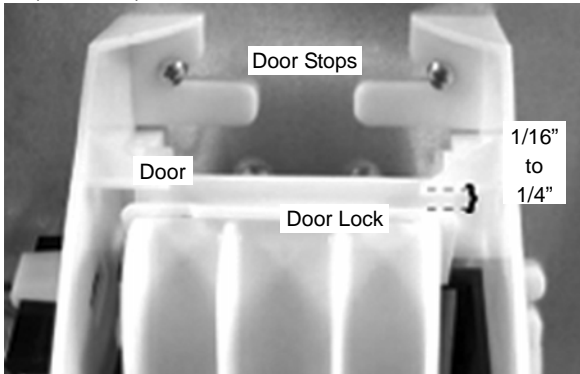

## Section 4 Maintenance

### Cleaning

#### DAILY CLEANING

All cleaning must meet your local health department regulations. The following cleaning instructions are provided as a guide.

#### **Caution**

Use only warm soapy water to clean the exterior of the tower. Do not use solvents or other cleaning agents. Do not pour hot coffee into the drain pan. Pouring hot coffee down the drain pan can eventually crack the drain pan, especially if the drain pan is cold or still contains ice.

#### **Warning**

##### **Electric Shock Hazard**

Unplug unit before servicing or cleaning.

#### **Warning**

When using cleaning fluids or chemicals, rubber gloves and eye protection should be worn.

Clean the exterior and drain pan:

1. Turn off the key switch located on either right or left side of the unit.
2. Lift the grid and remove it from the drain pan.
3. Using mild soap, warm water and a clean cloth, wipe the drain pan and splash panel. Then, rinse with clean, warm water. Allow plenty of warm (not hot) water to run down the drain of the drain pan, to remove syrup residue that can clog the drain opening.
4. Wash the grid, then rinse with clean water. Place the grid back in the drain pan.
5. Wash all exterior surfaces of the unit with warm water and a clean cloth. Wipe again with a clean, dry cloth.

Clean the dispensing valves:

6. Remove nozzles and diffusers from beverage valves.

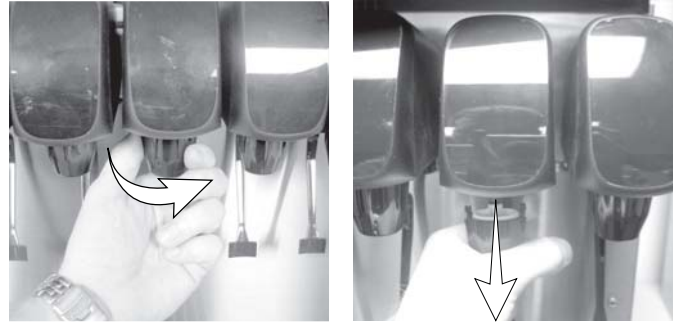

#### **Nozzle Removal**

7. Rinse nozzle and diffuser with warm, clean water.
8. Clean nozzles and diffusers with soapy water and a soft bristle brush.
9. Clean the underside of the beverage valves with warm, soapy water. Rinse with clean damp towel.
10. Replace nozzles and diffusers on valves.
11. Turn on the key switch.

**MONTHLY CLEANING** **Caution**

Unplug unit before servicing or cleaning ice bin.  
Ice bin contains parts that can move at any time and will cause injury if hands are in the way.

 **Warning**

When using cleaning fluids or chemicals, rubber gloves and eye protection must be worn.

Clean and sanitize the ice bin:

1. Unplug unit and remove all ice from the ice bin.
2. Mix a solution of mild detergent to clean the dispenser bin and components.
3. Wash the ice bin using a sponge and the mild detergent solution.
4. Using the mild detergent solution and a soft bristle brush or clean cloth, clean the following dispenser parts:
  - Entire bin
  - Paddle wheel
  - Paddle wheel area
  - Agitator
  - Paddle wheel pin
  - Ice Chute
  - Rear bushing
  - Motor shaft
  - Strip lids (where applicable)

5. Rinse all the parts in clean, running water.
6. Prepare 2 gallons of sanitizing solution by mixing 1/2 ounce of household bleach (that contains 5.25% sodium hypochlorite) with 2 gallons of 120°F water. The mixture should not exceed 100 PPM of chlorine. Or mix a solution of any approved sanitizer, following the directions for mixing and applying the sanitizer.
7. Sanitize the ice bin and cold plate with the sanitizing solution for at least 10 seconds.
8. Allow to air dry. Do not rinse.

Re-assembling the dispenser parts:

9. Re-assemble parts in the following order:
  - Bin liner
  - Paddle wheel
  - Agitator
  - Paddle wheel pin
  - Ice chute
  - Merchandiser
10. Hand tighten all knurled fasteners.
11. Pour in fresh, sanitary ice and replace the plastic lid on the top of the dispenser.
12. Plug in the unit's electrical cord.
13. Check for proper ice dispensing.

## Disassembly

### DISASSEMBLY FOR CLEANING & MAINTENANCE

NOTE: Sanitize the ice dispenser at Initial Start-up in addition to monthly sanitizing. You will need a slotted [screwdriver](#) in order to disassemble.

Disassemble parts in the following order:

- A. Merchandiser
- B. Ice chute
- C. Paddle wheel or agitator pins
- D. Agitator
- E. Paddle wheel
- F. Bin liner
- G. Paddle wheel area

Accessing a Dispenser Bin Top Mounted with a Manitowoc Ice Machine:

1. Remove the front panel of the ice machine.
2. Remove the ice deflection baffle. This will give you access to the dispenser bin.
3. If the Manitowoc ice maker is operating, wait for the sheet of ice to fall into the dispenser bin.

When the ice sheet falls into the dispenser bin, immediately place toggle switch of the ice machine to the OFF position. If the Manitowoc ice maker is NOT operating, place the toggle switch of the ice machine to the OFF position.

4. On models without a top mounted ice maker, remove the plastic lid from the top of the dispenser.
5. Remove all ice from the dispenser.
6. Disconnect electrical power to the dispenser.
7. Remove agitator arm and paddle wheel pin.
  - a. With agitator arm in any position remove hitch clip pin from the mushroom bushing on the rear of the ice bin.
  - b. Push the agitator bar toward the bushing to remove it from the paddle wheel hub.

NOTE: If a top mount ice maker is installed, sliding the ice maker to one side will make bin component removal easier. If the ice maker is hard plumbed it will need to be disconnected.

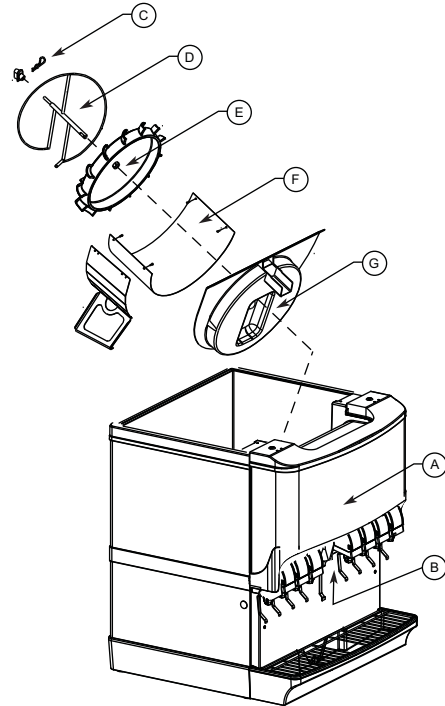

**Beverage/Ice Dispenser**

8. Remove paddle wheel, bin liner and paddle wheel area.
9. Move the front of the agitator to one side and slide the agitator forward until the rear of the agitator shaft is clear of the bushing.
10. Remove the agitator from the bin area.
11. Slide the paddle wheel from its shaft.
12. Loosen the four knurled fasteners that hold the bin liner in place.
13. Remove the bin liner.
14. Remove the paddle wheel area from the bin.
15. Discard the remaining ice in the bin.

**REMOVAL OF GEAR MOTOR**

These instructions are provided as a guide for the removal of the gear motor. Depending on the model number of your dispenser, these instructions may vary slightly.

1. Unplug the dispenser.
2. Unplug the motor.
3. Remove motor mount pins.
4. Slide motor towards you.
5. Notice alignment of the chamfered edge of drive shaft.
6. New motor must have the same alignment (within 15 degrees).
7. To get correct alignment you can do one of two things:
  - a. Turn drive shaft with an adjustable wrench, being careful not to damage the drive shaft.
  - b. Plug in the unit, plug in the motor and use the ice dispense switch to move the drive shaft into correct alignment.
8. If you plugged in the unit to help with alignment of drive shaft now unplug the unit.
9. Slide motor up into housing, making sure that the tabs fit on the bracket.
10. Install motor mount pins.
11. Plug in motor.
12. Test unit.

## Sanitizing

### BEVERAGE SYSTEM CLEANING

**Warning**

Flush sanitizing solution from syrup system.  
Residual sanitizing solution left in system could create a health hazard.

**Warning**

When using cleaning fluids or chemicals, rubber gloves and eye protection must be worn.

Sanitize the beverage system at initial start-up as well as regularly scheduled cleaning. The drain pan must be in place under soda valves, to carry away detergent and sanitizing agents that will be flushed through valves.

### BAG-IN-BOX SYSTEM SANITATION

**The procedure below is for the sanitation of one syrup circuit at a time. Repeat to sanitize additional circuits.**

You will need the following items to clean and sanitize the Bag-in-Box (BIB) beverage system:

- Three (3) clean buckets
- Plastic brush or soft cloth
- Mild detergent
- Unscented bleach (5% Na CL O) or Commercial sanitizer
- Bag-In-Box bag connector

1. Prepare the following in the buckets:

- Bucket 1 — warm to hot tap water for rinsing.
- Bucket 2 — mild detergent and warm to hot water.
- Bucket 3 — mix a solution of unscented bleach (5% Na CL O) or commercial sanitizer and warm to hot water. Mixture should supply 100 PPM available chlorine (1/4 oz. bleach to 1 gallon water).

2. Disconnect the “syrup-line side” of the bag-in-box connector.

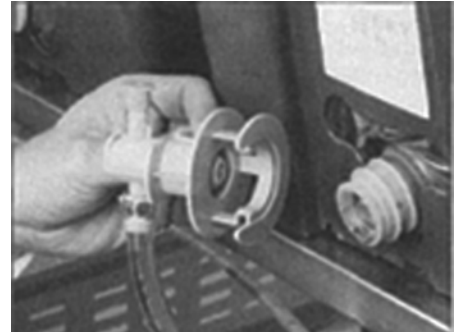

3. Rinse connector with warm tap water.

4. Connect syrup connector to BIB connector and immerse both into Bucket 1. A “bag-side” connector can be created by cutting the connector from an empty disposable syrup bag.

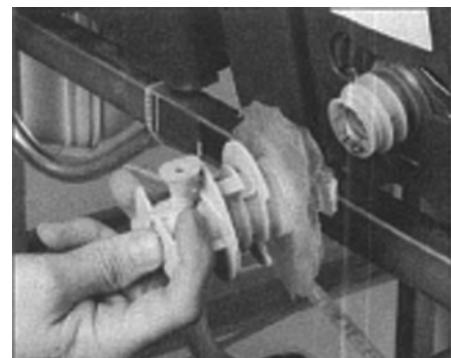
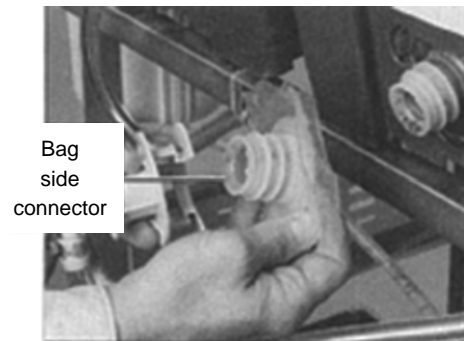

5. Draw rinse water through system until clean water is dispensed. Most beverage valves allow the syrup side to be manually activated by depressing the syrup pallet.
6. Connect Bucket 2 to system.
7. Draw detergent solution through system until solution is dispensed.
8. Repeat steps 2-7 until all syrup circuits contain detergent solution.
9. Allow detergent solution to remain in the system for 5 minutes.
10. Connect Bucket 3 to system.
11. Draw sanitizing solution through system until solution is dispensed.
12. Repeat step 11 until all syrup circuits contain sanitizer solution.
13. Allow sanitizer solution to remain in system for 15 minutes.
14. Remove nozzles and diffusers from beverage valves.
15. Scrub nozzles, diffusers and all removable valve parts (except electrical parts) with a plastic brush or a soft cloth and the detergent solution.
16. Soak nozzles, diffusers and removable valve parts (except electrical parts) in sanitizer for 15 minutes.
17. Replace nozzles, diffusers and valve parts.
18. Connect Bucket 1 to system.
19. Draw rinse water through system until no presence of sanitizer is detected.
20. Attach syrup connectors to BIB's.
21. Draw syrup through system until only syrup is dispensed.
22. Discard first 2 drinks.

## Preventive Maintenance

Preventative maintenance is a vital part of keeping your dispenser in top condition. Following the guidelines below will assist you in continued trouble-free operation of your unit.

1. Conduct daily maintenance of the machine.
2. Perform monthly maintenance of the machine.
3. Perform periodic maintenance and sanitizing of beverage system.
4. Do not overfill the dispenser bin with ice.
5. Do not allow the dispenser to sit for prolonged periods of non use with ice in the bin.
6. Most ice dispenser service problems are caused by low usage of the ice dispenser.
7. Do not allow ice to remain in the bin more than a day in order to prevent ice from freezing together and/or stagnant ice.

Possible excess ice storage reasons:

- Storage capacity exceeds daily requirements.
- Low demand during the off season.
- Dispenser oversized with future growth in mind.

Lower ice storage to meet one day's needs. If you manually fill ice, fill only with the appropriate amount of ice. Fill the dispenser with fresh ice each morning. Do not fill the dispenser at night just before shut down. Ice cubes can freeze together if not dispensed.

Contact MBE at 1-800-367-4233 for more information about our ProActive Maintenance Program.

## Shipping, Storage and Relocation

### **Caution**

Before shipping, storing, or relocating this unit, syrup systems must be sanitized. After sanitizing, all liquids (sanitizing solution and water) must be purged from the unit. A freezing environment causes residual sanitizing solution or water remaining inside the unit to freeze, resulting in damage to internal components.

## Section 5

### Before Calling for Service

#### Checklist

If a problem arises during operation of your dispenser, follow the checklist below before calling service. Routine adjustments and maintenance procedures are not covered by the warranty.

| Problem  | Possible Cause  | To Correct   |
|--|---|--|
| Dispenser will not dispense ice (and NO SOUNDS are heard when machine is activated). | No power.   | Check electrical connection.   |
|  | Loose wire in electrical system.  | Thoroughly check all wire connections.   |
|  | Dispenser overloaded with ice.  | Remove ice from dispenser until unit will operate.                                   |
|  | Motor not working.  | Check thermally protected motor.<br>Replace motor or capacitor if necessary.         |
| Dispenser will not dispense ice (motor runs but no ice movement is heard in bin).    | No ice in bin.  | Fill dispenser with ice.   |
|  | Door not opening.   | Check rocking chute mechanism or electric solenoid operation.                        |
|  | Paddle wheel pin slipped from the paddle wheel.   | Replace paddle wheel pin.  |
| Excessive clustering or bridging of ice.   | Loaded ice not broken up. (Caution: Super cooled ice is not covered by the Servend warranty.) | Break ice clusters before manually filling the dispenser. (See ice recommendations.) |
|  | Excessive water spilling from the ice maker.  | Adjust ice maker to eliminate water spillage.  |
|  | Poorly adjusted ice maker.  | Adjust ice maker to eliminate large waffle shapes.                                   |
|  | Extremely low usage of the dispenser.   | Lower the ice level in the bin.  |
| Ice dispenses continuously.  | Misaligned microswitch.   | Adjust microswitch.  |
|  | Agitation timer set incorrectly.  | Test agitation timer.  |
| Thumping noise or irregular sound at a particular area of the dispenser.             | Shaved ice clusters in the bin.   | Remove clusters, discover why ice is shaving, and then repair.                       |
| Dispensing crushed ice or reduced dispensing speed.                                  | Water spillage from ice machine into dispenser bin.   | Adjust ice maker.  |
|  | Agitation timer.  | Test agitation timer.  |
|  | Bridge of ice sheet is too thick.   | Adjust ice maker.  |
|  | Paddle wheel area broken or cracked.  | Replace paddle wheel area.   |
|  | Ice clusters in bin.  | Break up or remove clusters.   |
| Door will not close.   | Door not fully open.  | Adjust door.   |
|  | Ice jammed in chute.  | Adjust bridge in ice maker or, when manually filling, break up clusters.             |
| Door and/or door lock has come out of place.   |   | Replace door and lock into proper position.  |
|  |   |  |
| Mounting brackets for rocking chute have spread too far apart.                       |   | Bend parts into shape.   |

THIS PAGE INTENTIONALLY LEFT BLANK

EC DECLARATION OF CONFORMITY

We hereby declare that our products, ice machines and Multiplex refrigeration equipment comply with all the essential requirements of the listed EC - directives.

Manufacturer:

Manitowoc Ice, Inc.  
2110 S. 26th Street, P.O. Box 1720  
Manitowoc, Wisconsin 54221-1720 USA

European Distributor:

\_\_\_\_\_  
\_\_\_\_\_  
\_\_\_\_\_

Representative of Manitowoc Ice, Inc.:

Engineering Manager, (Printed name)

Signature

\_\_\_\_\_

Representative of European Distributor:

\_\_\_\_\_

Model and Serial No.

Applied Standards:

EN60335-1 Safety of household and similar electrical appliances  
EN60335-2-24 Particular requirements refrigerators, food freezers and ice makers

EN55014 Electrical Motor Operated Appliances (Emissions)  
EN55014 Electro Magnetic Compatibility (Immunity)  
EN378 -1 to -4 Refrigeration Plants

Applied EC Directives:

Low Voltage 73/23/EEC  
EMC 89/336/EEC  
Pressure Equipment 97/23/EC



8201043  
08/25/03

Continuing product  
improvements may necessitate  
change of specifications without  
notice.

Part Number **020002115** 10/11



Multiplex  
645 Park East Blvd, Suite 5  
New Albany, IN 47150, USA  
Ph: 844-724-2273 Fax: 812-246-7020  
Visit us online at: [www.multiplexbeverage.com](http://www.multiplexbeverage.com)