



Selectable Ice Beverage/Ice Dispensers

Installation, Use & Care Manual

This manual is updated as new information and models are released.
Visit our website for the latest manual. www.manitowocfsg.com

Safety Notices

As you work on Manitowoc equipment, be sure to pay close attention to the safety notices in this manual. Disregarding the notices may lead to serious injury and/or damage to the equipment.

Throughout this manual, you will see the following types of safety notices:

Warning

Text in a Warning box alerts you to a potential personal injury situation. Be sure to read the Warning statement before proceeding, and work carefully.

Caution

Text in a Caution box alerts you to a situation in which you could damage the equipment. Be sure to read the Caution statement before proceeding, and work carefully.

Procedural Notices

As you work on Manitowoc equipment, be sure to read the procedural notices in this manual. These notices supply helpful information which may assist you as you work.

Throughout this manual, you will see the following types of procedural notices:

Important

Text in an Important box provides you with information that may help you perform a procedure more efficiently. Disregarding this information will not cause damage or injury, but it may slow you down as you work.

NOTE: Text set off as a Note provides you with simple, but useful, extra information about the procedure you are performing.

Read These Before Proceeding:

Caution

Proper installation, care and maintenance are essential for maximum performance and trouble-free operation of your Manitowoc equipment. Read and understand this manual. It contains valuable care and maintenance information. If you encounter problems not covered by this manual, do not proceed, contact Manitowoc Foodservice Group. We will be happy to provide assistance.

Important

Routine adjustments and maintenance procedures outlined in this manual are not covered by the warranty.

Warning

PERSONAL INJURY POTENTIAL

Do not operate equipment that has been misused, abused, neglected, damaged, or altered/modified from that of original manufactured specifications.

NOTE: SAVE THESE INSTRUCTIONS.

We reserve the right to make product improvements at any time. Specifications and design are subject to change without notice.

Table of Contents

Section 1

General Information

Read This Manual	1-1
Unit Inspection	1-1
Model Numbers	1-1
How to Read a Model Number	1-1
Accessories	1-1
Baffle for Manitowoc® Ice Machines	1-1
Manual Fill Lid for Dispensers with an Ice Machine	1-2
Legs	1-2
Serial Number Location	1-2
Warranty Information	1-2

Section 2

Installation Instructions

General	2-1
Dimensions	2-1
Selectable Ice Dispenser	2-1
Footprint	2-2
Location	2-3
Location Requirements for Top Mounted Ice Machine Installations	2-3
Pre-installation Checklist	2-4
Essential Tools	2-4
Locations Of The Following:	2-4
Top Mounted Ice Machine Installations	2-5
Electrical	2-6
General	2-6
Minimum Circuit Ampacity	2-6
Electrical Requirements	2-6
Voltage	2-6
Minimum Circuit Amperage Chart	2-6
Grounding Instructions	2-6
Pump Deck Wiring	2-7
Water Supply	2-8
Recommended Plumbing	2-8
Diagram & Flex Manifold Locations	2-8
Capacities	2-11
Specifications Chart	2-11

Table of Contents (continued)

CO₂ Supply	2-12
Routing Internal Carb Tank Purge Tube	2-12
Drains	2-12
Step by Step Installation	2-13
General	2-13
Specifications Chart	2-13
Unit Installation	2-13
Pre-mix Pressures	2-14
Cold Carb and Ambient System Pressures	2-14
ADA Key Pads	2-15
Starting Your Beverage System & Dispenser	2-16

Section 3 Operation

General System Overview	3-1
Component Identification	3-2
Dispenser	3-2
Selectable ICe Module	3-3
Selectable Ice Module with Flavor Magic	3-3
Sequence of Operation	3-4
Ice Recommended for Dispensing	3-4
Ice Storage and Dispensing	3-4
Selectable Ice Sequence of Operation	3-4
Beverage Valves	3-4
Carbonation	3-4
Syrup Delivery System	3-5
Back Room Package	3-5
Racking	3-5
B-I-B	3-5
Pumps	3-5
Auto Bag Selectors	3-5
Figal System	3-6
Figal Tanks	3-6

Table of Contents (continued)

Programming Modes	3-7
Selectable Ice Non-Adjustable Agitation	3-7
Crushed or Cubed Default	3-7
agitation timer operational check	3-7
Flavor Magic Modes	3-7
Program Dispense Time	3-7
Purge / Sanitize	3-7
Flavor Magic Dispensing Modes	3-8
Changing number of Active Flavors	3-8
Time Delay after Dispense	3-8
Control Logic Matrix - Flavor Magic	3-9

Section 4 Maintenance

Preventive Maintenance	4-1
Cleaning	4-1
Daily Cleaning	4-1
Monthly Cleaning	4-2
Disassembly	4-3
for Cleaning & Maintenance	4-3
Selectable Ice Crusher	4-4
reassemble the Ice Crusher assembly	4-4
Front Serviceable Gear Motor Removal	4-5
Sanitizing	4-6
Beverage System Cleaning	4-6
Bag-In-Box System Sanitation	4-6
Flavor Magic	4-7
Figal Beverage System	4-9
Shipping, Storage and Relocation	4-9

Section 5 Before Calling for Service

Checklist	5-1
Dispenser General	5-1
Selectable Ice	5-2
Drinks	5-3
Flavor Shots	5-4
Pump	5-4

Table of Contents (continued)

Section 1

General Information

Read This Manual

Manitowoc Beverage Equipment (MBE) developed this manual as a reference guide for the owner/operator and installer of this equipment. Please read this manual before installation or operation of the machine. A qualified service technician must perform installation and start-up of this equipment, consult **Section 5** within this manual for service assistance.

If you cannot correct the service problem, call your MBE Service Agent or Distributor. Always have your model and serial number available when you call.

Your Service Agent _____

Service Agent Telephone Number _____

Your Local MBE Distributor _____

Distributor Telephone Number _____

Model Number _____

Serial Number _____

Installation Date _____

Unit Inspection

Thoroughly inspect the unit upon delivery. Immediately report any damage that occurred during transportation to the delivery carrier. Request a written inspection report from a claims inspector to document any necessary claim.



Warning

PERSONAL INJURY POTENTIAL

Do not operate equipment that has been misused, abused, neglected, damaged, or altered/modified from that of original manufactured specifications.

Model Numbers

This manual covers the following models:

Beverage/Ice Dispensers
SV-200 SCI, SV-200i SCI, SV-250i SCI, SV-250 SCI

How to Read a Model Number

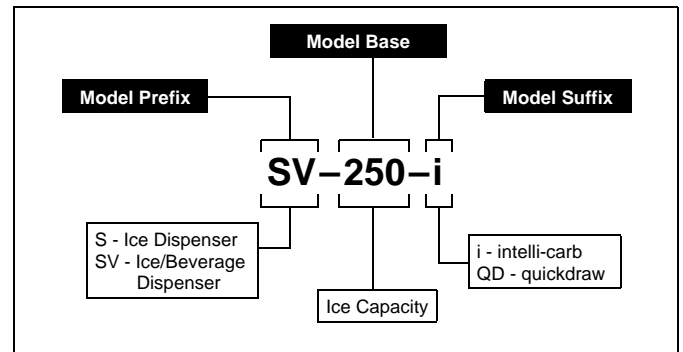

Accessories

BAFFLE FOR MANITOWOC® ICE MACHINES

When installing a Manitowoc Ice Machine on a dispenser, a baffle kit is required for proper installation. The baffle kit is designed to prevent ice from lying against the front of the ice machine, and melting down the front of the dispenser. There are two different baffle kits available for "S" series ice machines, one kit is for the 30" wide machine, and the other kit is for the 22" wide machine. There is also a kit for "Q" series ice machines.

Kits are available through your local distributor. List prices may be subject to change without notification. Please call your local parts distributor for current pricing before ordering.

NOTE: For full information about ice machine installation, including plumbing lines connections and electrical requirements, see the ice machine installation manual.

MANUAL FILL LID FOR DISPENSERS WITH AN ICE MACHINE

If you are top mounting your dispenser with an ice machine, you will require a lid for the manual fill area at the top, front of the dispenser.

If you ordered a dispenser and an ice machine at the same time, the manual fill lid was included with the unit. The manual fill lid can be ordered from your local distributor.

LEGS

Legs are optional equipment with most MBE dispensers. Standard legs are 4" (10.2 cm) tall stainless steel legs. If an ice machine is installed on top of the dispenser, legs must not be installed. We do not recommend using legs when an ice machine is mounted on the dispenser. The combined weight of the dispenser, ice and ice machine is more evenly distributed when the base area of the dispenser is in contact with the countertop.

Serial Number Location

This number is required when requesting information from your local distributor. The serial number is listed on the SERIAL NUMBER DECAL affixed to the dispenser.

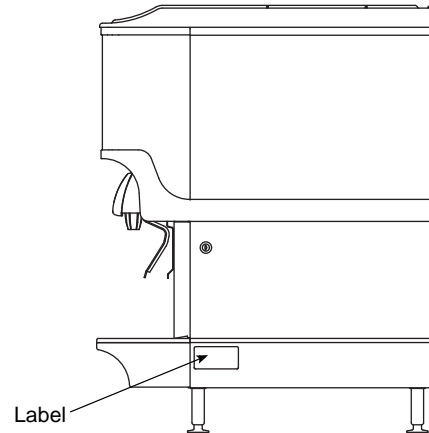

Serial Number Location

Warranty Information

Consult your local MBE Distributor for terms and conditions of your warranty. Your warranty specifically excludes all beverage valve brixing, general adjustments, cleaning, accessories and related servicing.

Your warranty card must be returned to MBE to activate the warranty on this equipment. If a warranty card is not returned, the warranty period can begin when the equipment leaves the MBE factory.

No equipment may be returned to MBE without a written Return Materials Authorization (RMA). Equipment returned without an RMA will be refused at MBE's dock and returned to the sender at the sender's expense.

Please contact your local MBE distributor for return procedures.

Section 2 Installation Instructions

General

These instructions are provided to assist the qualified installer. Contact your Manitowoc Beverage Equipment Service Agent or call Manitowoc Beverage Equipment for information regarding start-up services.

Important

Failure to follow these installation guidelines may affect warranty coverage.

Dimensions

SELECTABLE ICE DISPENSER

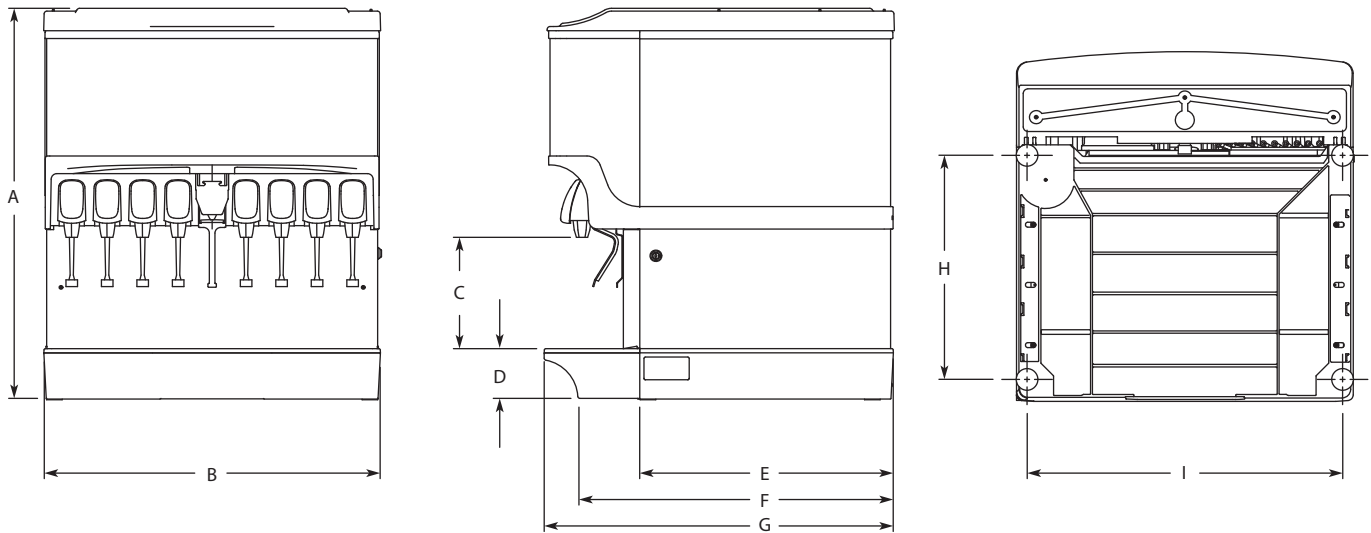

Model/Ice Capacity	A	B	C	D	E	F	G	H	I
SV-200/250SCI	34.81" (88.4 cm)	30.00" (76.2 cm)	9.94" (17.6 cm)	4.44" (11.3 cm)	22.63" (57.5 cm)	28.00" (71.1 cm)	31.13" (79.1 cm)	20.00" (50.8 cm)	27.44" (69.7 cm)

FLAVOR MAGIC

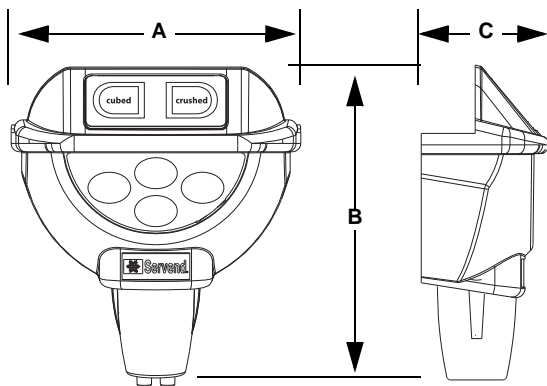

* For Units with this feature

Flavor Magic	A	B	C
Module*	4.66" (11.84 cm)	5.08" (12.90 cm)	1.97" (5.00 cm)

Footprint

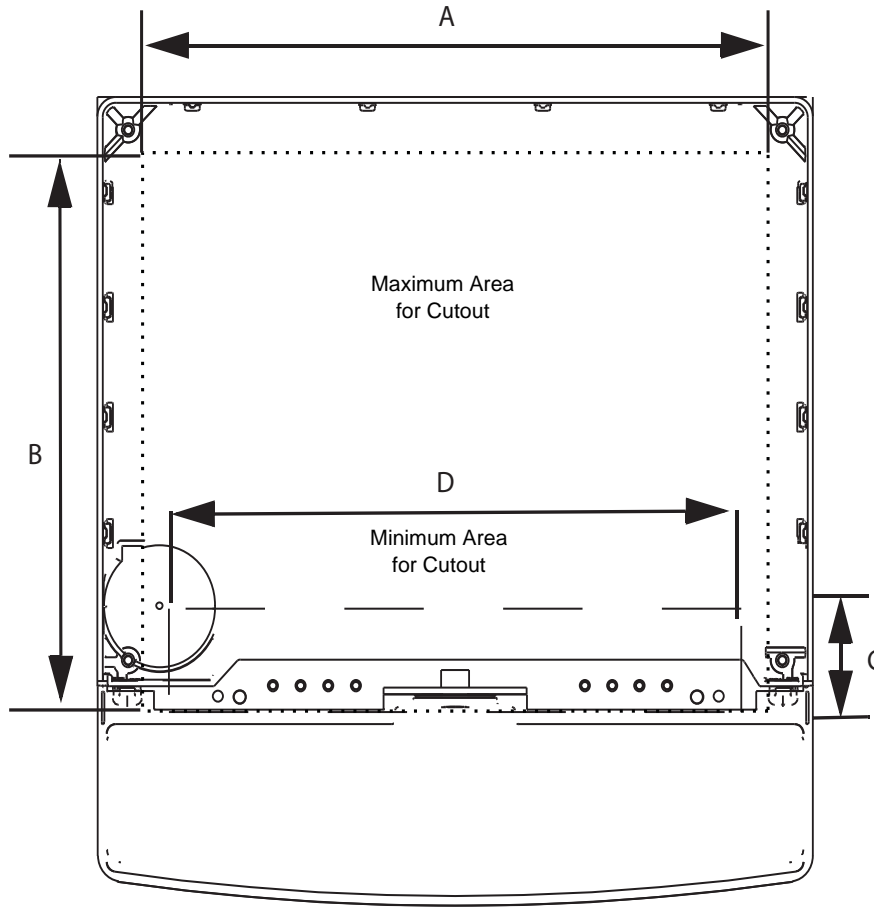

Selectable Ice	Maximum		Minimum	
	A	B	C	D
SV-200/250SCI	26.00" (66.0 cm)	17.81" (45.2 cm)	4.00" (20.30 cm)	24.00" (61.00 cm)

⚠ Caution

Cutting the countertop may decrease its strength. Counter must be braced to support the dispenser countertop weight plus ice storage capacity and weight of icemaker, if applicable.

Location

The location selected for the beverage dispenser must meet the following criteria. If any of these criteria are not met, select another location.

- The air temperature must be at least 50°F (10°C), but must not exceed 95°F (35°C).
- The location must not be near heat-generating equipment or in direct sunlight and must be protected from weather.
- The countertop must be level. Verify that the countertop can support the weight of the dispenser, or the dispenser/ice machine combination plus the weight of the stored ice.
- Water lines, drains and power outlet must be within 6' (1.8 m) of location.

Warning

Carbon Dioxide (CO₂) displaces oxygen. Exposure to a high concentration of CO₂ gas causes tremors, which are followed rapidly by loss of consciousness and suffocation. If a CO₂ gas leak is suspected, particularly in a small area, immediately ventilate the area before repairing the leak. CO₂ lines and pumps must not be installed in an enclosed space. An enclosed space can be a cooler or small room or closet. This may include convenience stores with glass door self serve coolers. If you suspect CO₂ may build up in an area, venting of the B-I-B pumps and / or CO₂ monitors must be utilized.

Location Requirements for Top Mounted Ice Machine Installations

Location — Avoid placing the dispenser and/or ice machine near heat sources such as radiators, ovens, refrigeration equipment and direct sunlight.

Clearances — Refer to the ice machine installation manual for clearances.

Front of ice machine to be flush with front of dispenser — Some ice machines may overhang at the back of the dispenser.

Drains — A separate drain line is required for the ice machine, in addition to a drain line for the ice/beverage dispenser.

Dispensers may require an adapter kit to install some top-mounted ice machines. Contact your local distributor for the correct adapter kit.

For full information about ice machine installation, including clearances, plumbing lines, connections, and electrical requirements, see the ice machine installation manual.

Pre-installation Checklist

When installing any system, first make sure the major components are available. Generally the major components necessary for an installation are:

ESSENTIAL TOOLS

- Tubing Cutters
- Oetiker pliers
- Phillips and slotted [screwdriver](#)
- Power drill
- Six (6) inch adjustable wrench
- Tape Measure

- Beverage tubing
- CO₂ tank
- Carbonator
- Stepless (Oetiker) clamps
- Chain for CO₂ tank

Pre-mix System:

- CO₂ regulator set
- Product connectors for Figal tank
- Gas connectors for Figal tank
- Beverage dispenser
- Beverage tubing
- CO₂ tank
- Figal beverage tanks
- Stepless (Oetiker) clamps
- Chain for CO₂ tank

Bulk Syrup System also:

- Syrup connectors for Bulk tank
- Gas connectors for Bulk tank
- Bulk syrup tanks

Double Check:

- Do you have enough space to install the dispenser or a dispenser and top mounted ice machine?
- Does top mounted ice machine (if utilized) have a minimum of 6 inches (15.3 cm) clearance on all sides?
- Is the countertop level?
- Can the countertop support the weight of the dispenser, or the dispenser/ice machine combination plus the weight of the stored ice?

B-I-B System also:

- B-I-B connectors
- B-I-B regulator set
- B-I-B rack
- B-I-B syrup boxes

LOCATIONS OF THE FOLLOWING:

- Water line
- Drain
- Power outlet
- Heating and air conditioning ducts

Post Mix System:

- CO₂ regulator set
- Beverage dispenser

TOP MOUNTED ICE MACHINE INSTALLATIONS

- Location** — Avoid placing the dispenser and/or ice machine near heat sources such as radiators, ovens, refrigeration equipment and direct sunlight.
- Clearances** — Six inch (15.2 cm) clearance on all sides of the icemaker is needed.
- Front of icemaker to be flush with front of dispenser** — The front of the icemaker must be flush with the front of the dispenser. When the icemaker is flush with the front of the dispenser, some icemakers may overhang at the back of the dispenser.
- Drains** — A separate drain line is required for the ice machine, in addition to a drain line for the ice/beverage dispenser.
- Dispensers may require an adapter kit to install some top-mounted icemakers. Contact your local distributor for the correct adapter kit.

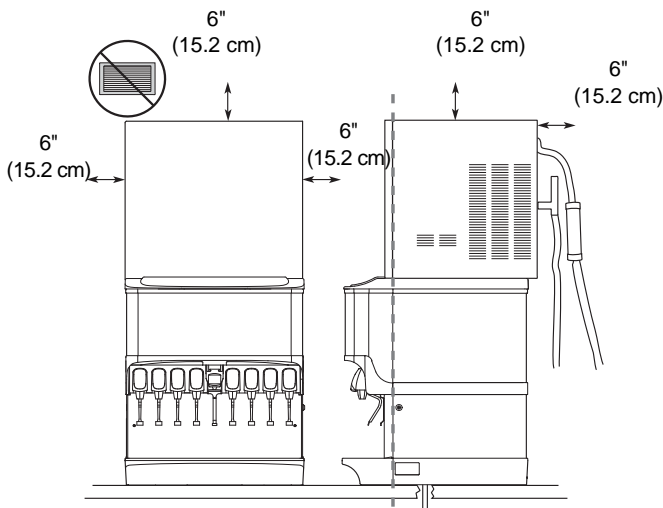

NOTE: For full information about icemaker installation, including plumbing lines connections and electrical requirements, see the icemaker installation manual.

S Series Baffle Installation

1. Remove both front panels.
2. Examine the ice machine to see if the machine has four screws on the lower front plastic panels.
3. If there are screws, remove them from the countersunk holes on the front surface of the machine, save the screws.
4. Install the deflector, using the four screws removed in step three.

5. Four screws and two backing plates are in the kit.
6. If there are no screws on the ice machine (step 2), pierce the thin plastic countersunk holes, install the backing plates and install the deflector using the screws from the kit.
7. Replace the front panels.

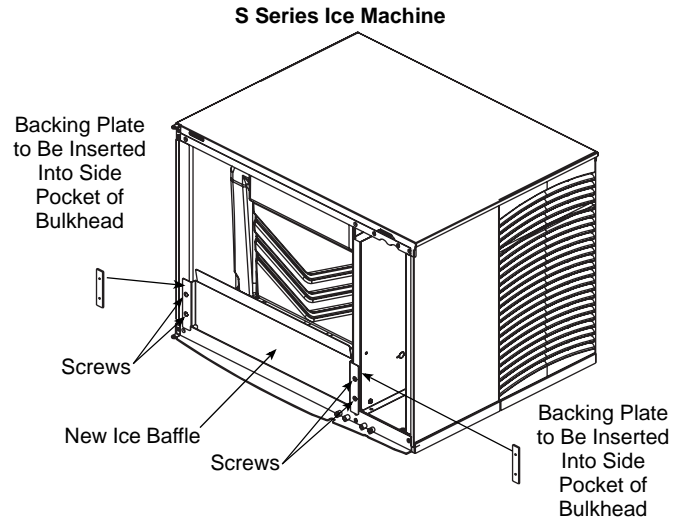

Q Series Baffle Installation

1. Position baffle on top of water well with tab on the front and the other tab inside the water well.
2. Mount the baffle on the left side of the ice machine using the hole and screw provided.

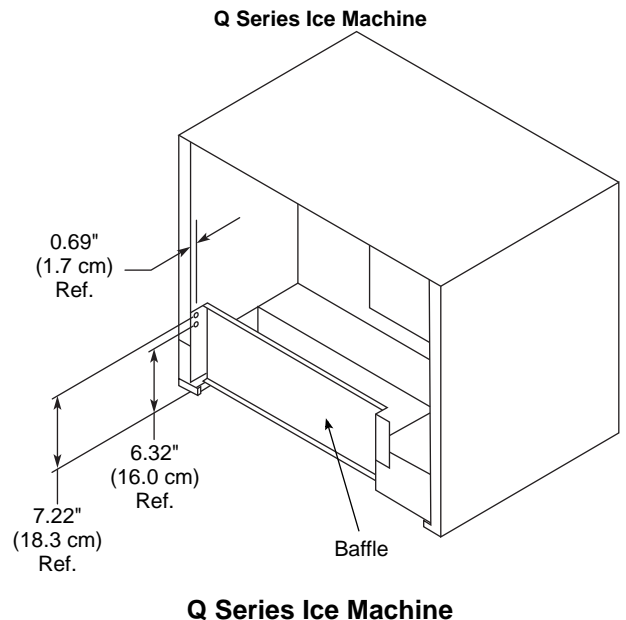

Electrical

GENERAL

 **Warning**

All wiring must conform to local, state and national codes.

MINIMUM CIRCUIT AMPACITY

The minimum circuit ampacity is used to help select the wire size of the electrical supply. (Minimum circuit ampacity is not the beverage/ice machine’s running amp load.) The wire size (or gauge) is also dependent upon location, materials used, length of run, etc., so it must be determined by a qualified electrician.

ELECTRICAL REQUIREMENTS

Refer to Ice Machine Model/Serial Plate for voltage/amperage specifications.

VOLTAGE

The standard voltage for Selectable Ice Series dispensers is 120VAC-60Hz. A power cord is provided with 120VAC-60Hz models only. S/SV/SVI/NGF Series dispensers use a 1/7 hp gearmotor.

MINIMUM CIRCUIT AMPERAGE CHART

Important

Due to continuous improvements, this information is for reference only. Please refer to the dispenser serial number tag to verify electrical data. Serial tag information overrides information listed on this page.

Dispenser	Voltage/Cycle	Minimum Circuit Amps
SV-250SCI, SV-250SCI	115/60	2.8

GROUNDING INSTRUCTIONS

 **Warning**

The beverage/ice machine must be grounded in accordance with national and local electrical codes.

This appliance must be grounded. In the event of malfunction or breakdown, grounding provides a path of least resistance for electric current to reduce the risk of electric shock. This appliance is equipped with a cord having an equipment-grounding conductor and a grounding plug. The plug must be plugged into an appropriate outlet that is properly installed and grounded in accordance with all local codes and ordinances.

 **Warning**

Improper connection of the equipment-grounding conductor can result in a risk of electric shock. The conductor with insulation having an outer surface that is green with or without yellow stripes is the equipment grounding conductor. If repair or replacement of the cord or plug is necessary, do not connect the equipment-grounding conductor to a live terminal. Check with a qualified electrician or serviceman if the grounding instructions are not completely understood, or if in doubt as to whether the appliance is properly grounded. Do not modify the plug provided with the appliance — if it will not fit the outlet, have a proper outlet installed by a qualified electrician.

 **Warning**

When using electric appliances, basic precautions must always be followed, including the following:

- a. Read all the instructions before using the appliance.
- b. To reduce the risk of injury, close supervision is necessary when an appliance is used near children.
- c. Do not contact moving parts.
- d. Only use attachments recommended or sold by the manufacturer.
- e. Do not use outdoors.
- f. For a cord-connected appliance, the following shall be included:
 - Do not unplug by pulling on cord. To unplug, grasp the plug, not the cord.
 - Unplug from outlet when not in use and before servicing or cleaning.
 - Do not operate any appliance with a damaged cord or plug, or after the appliance malfunctions or is dropped or damaged in any manner. Contact the nearest authorized service facility for examination, repair, or electrical or mechanical adjustment.
- g. For a permanently connected appliance — Turn the power switch to the off position when the appliance is not in use and before servicing or cleaning.
- h. For an appliance with a replaceable lamp — Always unplug before replacing the lamp. Replace the bulb with the same type.
- i. For a grounded appliance — Connect to a properly grounded outlet only. See Grounding Instructions.

PUMP DECK WIRING

The supply cord is equipped with a three prong 5-15P. When a Ground Fault Circuit Interrupter (GFCI) is required by code, a breaker type protector must be used. We do not recommend GFIC outlets as they are known for more intermittent nuisance trips than panel breakers. To ensure both the safety and proper operation of this equipment, be certain that the electrical receptacle is a proper design so as to accept this plug, ensuring that the carbonator assembly is properly grounded.

If the pump deck is to be installed in an area or community whose local codes require permanent wiring, the following procedure must be followed.

1. The three wires (white, black and green) must be fed through the cable connector and brought into the wiring compartment. The cable must be secured into the connector.
2. The green wire from the cable must be connected to the green screw that attaches to the inside panel of the wiring compartment. Be sure to use a ring torque terminal for connecting the wire to the screw.
3. The white wire from the cable must be joined to the N terminal of the liquid level control board by a suitable U.L. listed insulated cable connector.
4. The black wire from the cable must be joined to the L1 terminal of the liquid level control board by a suitable U.L. listed insulated cable connector.

Water Supply

RECOMMENDED PLUMBING

The plumbing diagram is printed on a white vinyl label, located above the inlet tubes for syrup and water. The plumbing diagram label can be accessed by removing the splash panel of the dispenser. The plumbing diagram label explains which inlet coldplate fittings supply which dispenser valves and water manifolds.

The water supply must first be connected to the carbonator pump (not shown) before plumbing to connection “A” shown on plumbing diagram. The carbonator pump deck must be within six feet of the dispenser for optimum performance. See BIB installation diagram for system pressure settings.

DIAGRAM & FLEX MANIFOLD LOCATIONS

Important

When installing cold carbonated (Intelli carb) equipment, never put a tee for the plain water connection in the line from the pump deck to the cold plate. Putting a tee in the line will create service problems and bad drink quality.

NOTE: Valves are read from right to left.

A check valve must be installed in the water supply line 3 feet from the noncarbonated water connection “PW”. Contact factory if not installed.

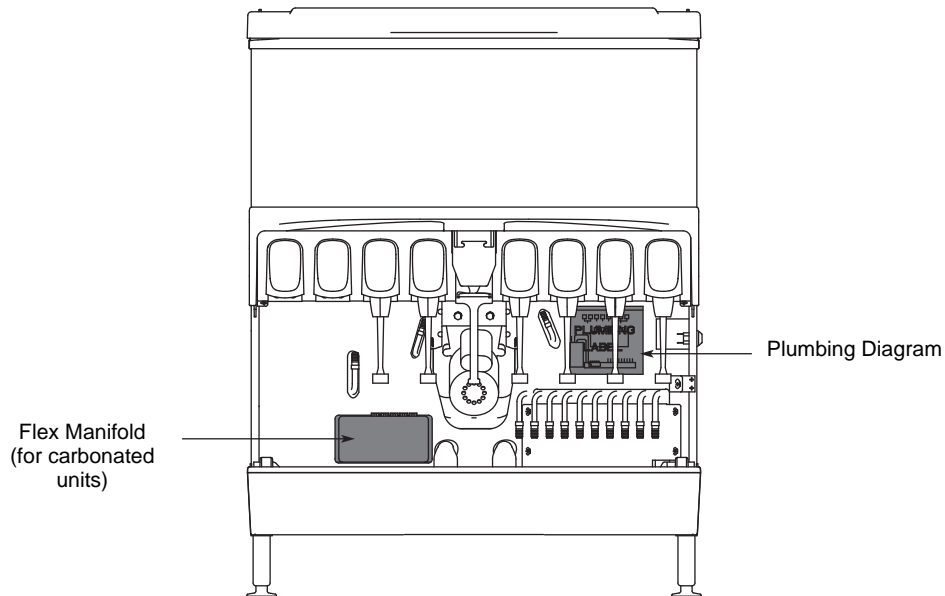

SV200/250 8 Valve Diagram

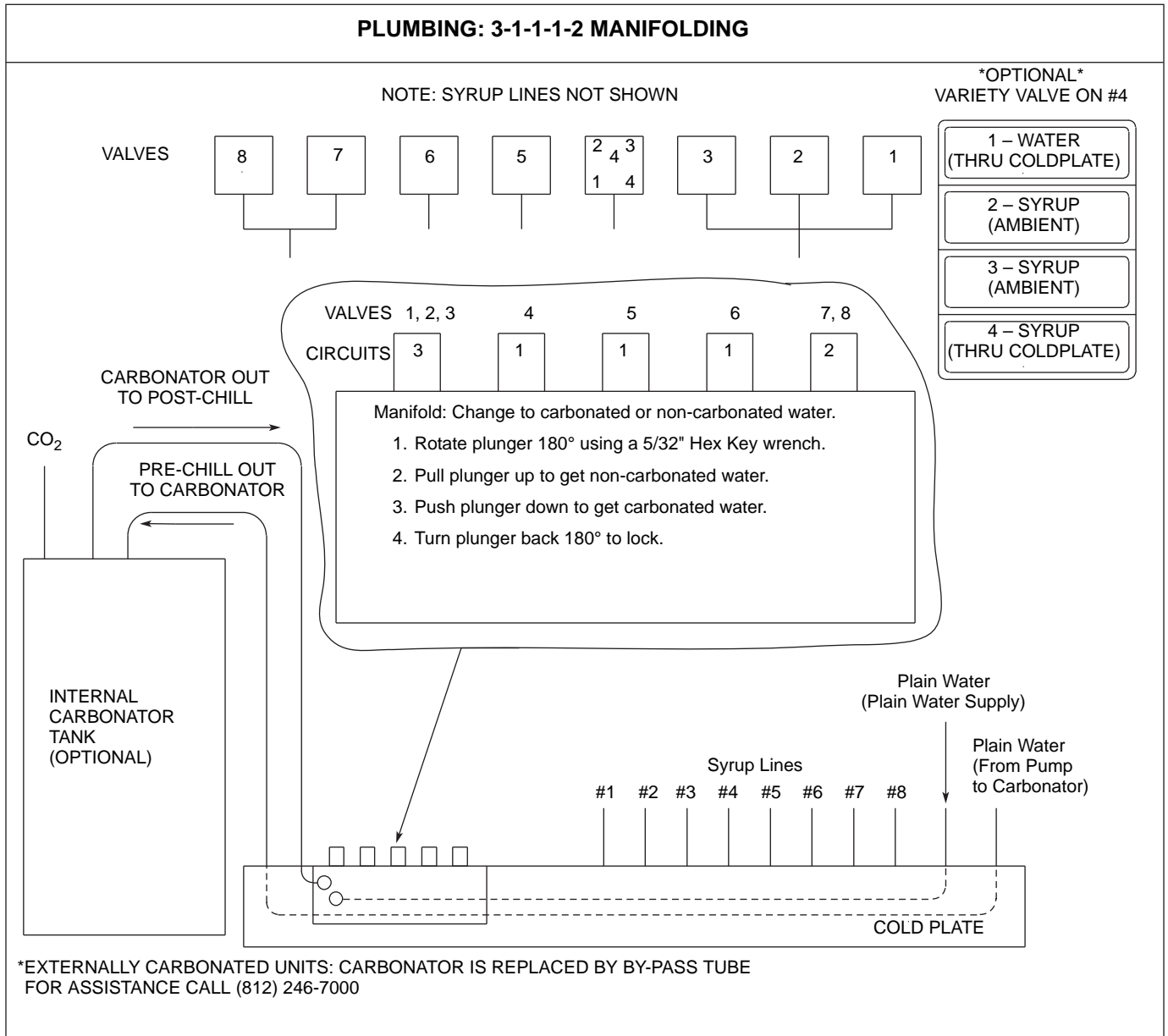

SV200/250 10 Valve Diagram

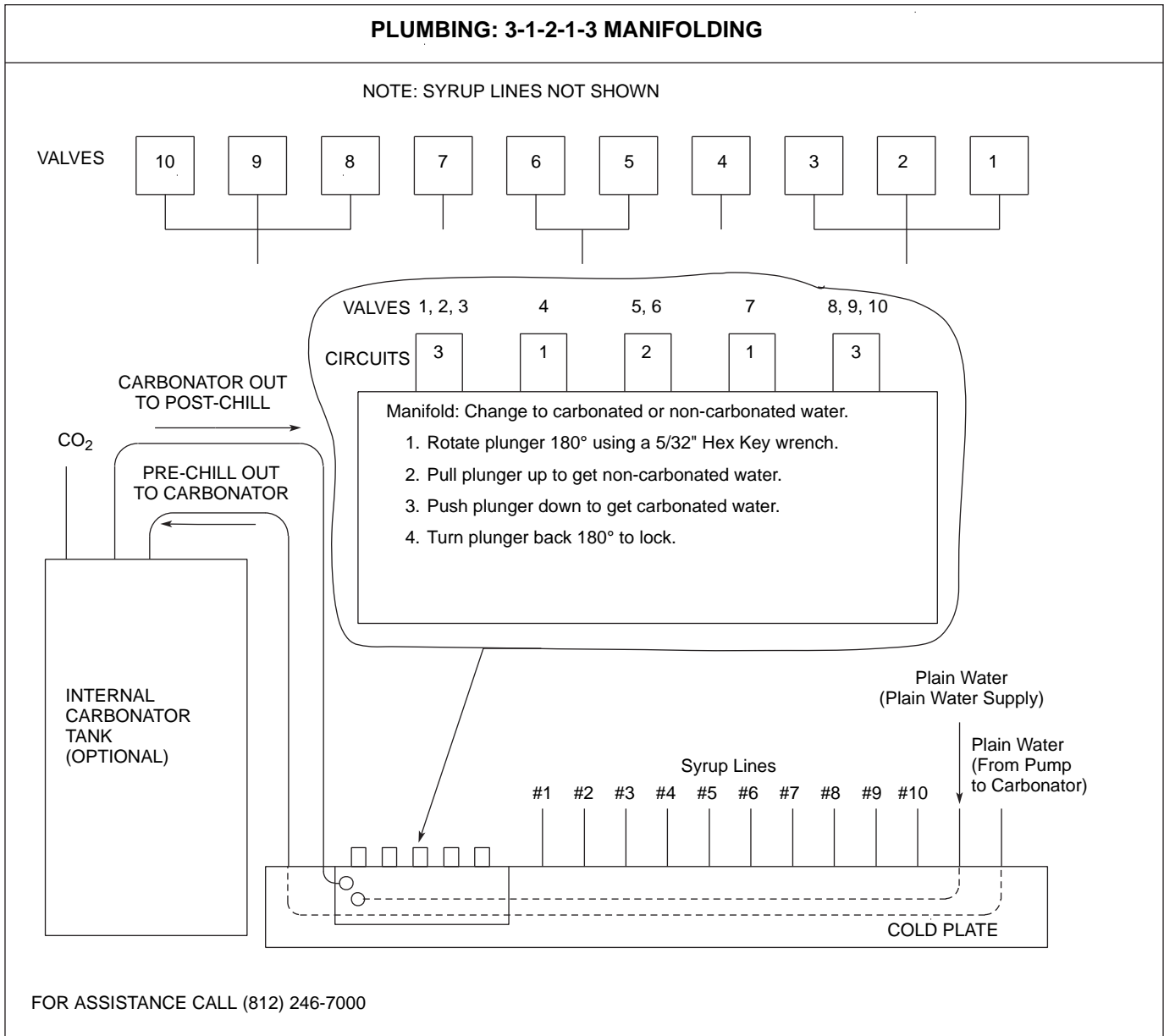

Flavor Magic

(For units with this feature)

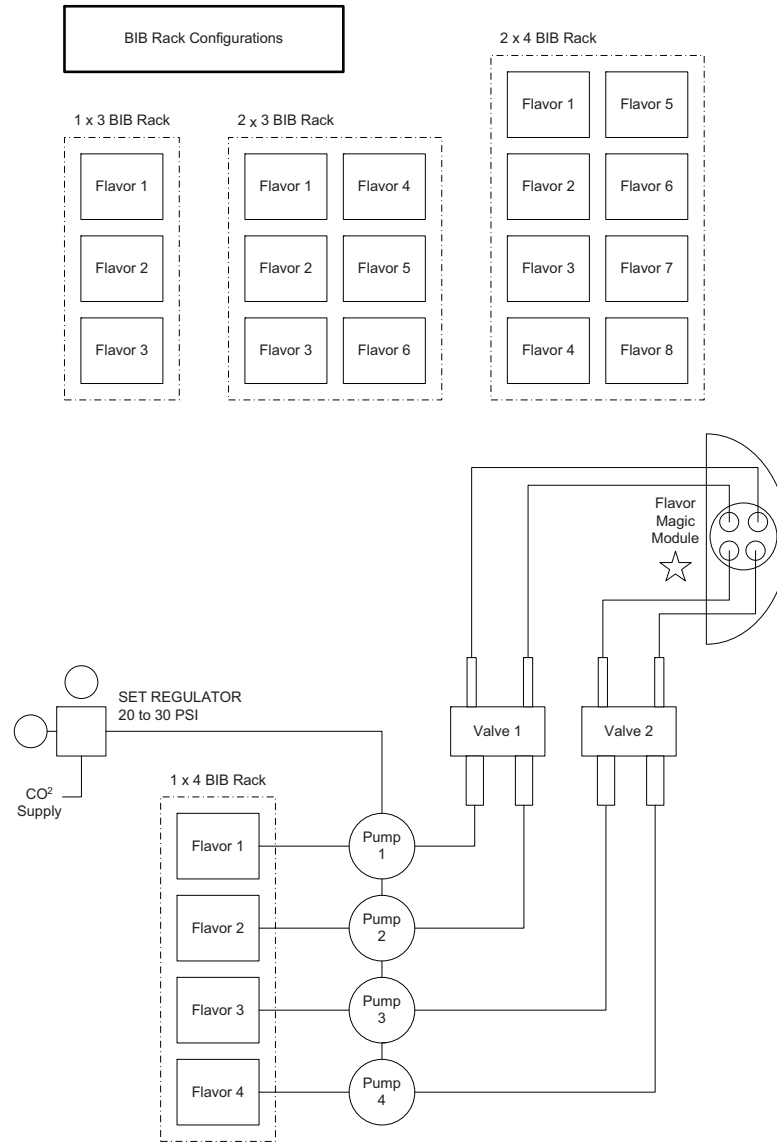

CAPACITIES

Module	Valves	Flow Rate	Dispense Time
Flavor Magic	1 per flavor, up to 4 flavors	Variable, 0.5 oz/ sec nominal	0.2 - 10 seconds, adjustable in 0.2 second increments

SPECIFICATIONS CHART

	MIN.	MAX
Dispenser Incoming Plain Water Pressure	40 psi dynamic	70 psi static
Ambient Temperature	40°F (4°C)	105°F (41°C)
B-I-B (Secondary)	75 psi or according to line run	
Flavor Magic Regulator	20 psi MAX or according to line run	

CO₂ Supply

ROUTING INTERNAL CARB TANK PURGE TUBE

Some models are equipped with an internal carbonation tank. These models require that the purge/pressure relief tubing be routed to a drain.

1. Remove the splash panel.
2. Uncoil tubing and route between the front of the dispenser and the drain pan.

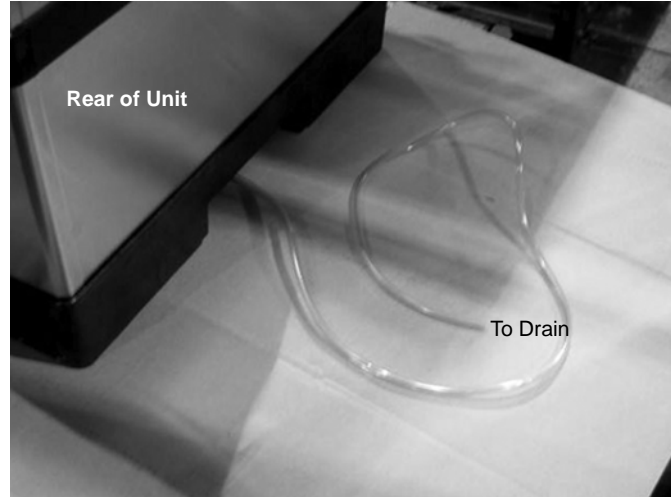
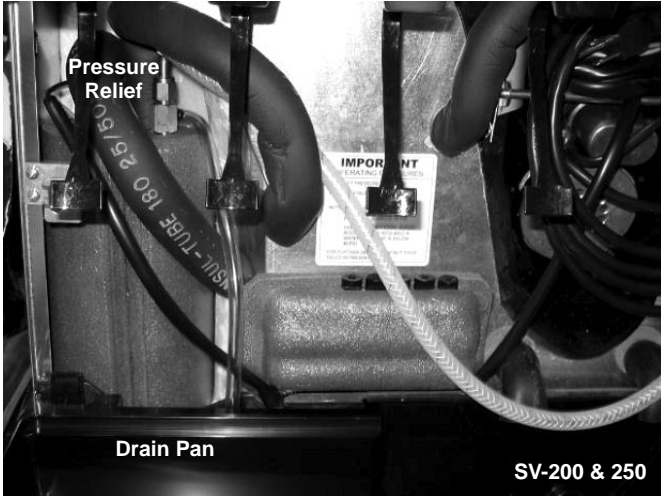

4. Verify the tubing is not kinked and then secure tubing to maintain a minimum 1" (2.5 cm) air gap at the drain. Follow any applicable local or national codes.

3. Depending on drain location route the tubing through the tubing bundle cutout or out the back of the dispenser.

Drains

SV Series dispensers drain through a double connection to the drain pan.

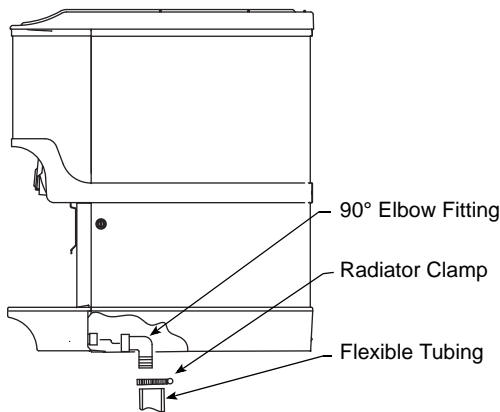

Drainage Through Bottom

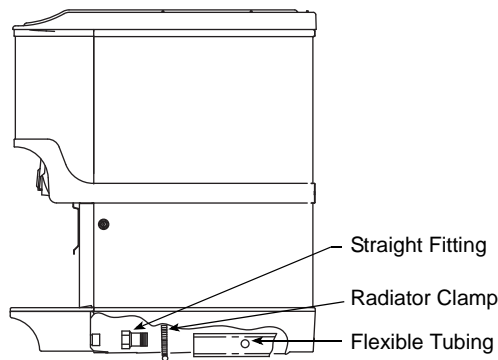

Drainage Through Back

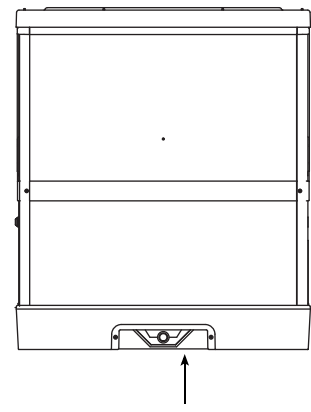

Rear View

Step by Step Installation

GENERAL

SV Series dispensers have a stainless steel cabinet and lighted merchandiser standard.

Beverage valves, coldplate connections, drain connections and electrical components are front serviceable.

SPECIFICATIONS CHART

	Min.	Max
Water pressure	40 psi	55 psi
Ambient temperature	40°F (4°C)	105°F (41°C)
CO ₂ pressure	40 psi	50 psi
Electrical	115V/60 Hz/1	
Pre-mix pressure		
Normal	60 psi*	
Diet	40 psi*	
B-I-B	60 psi or according to line run	
Carbonation		
Cold	75 psi	
Ambient	90 psi	105 psi

* This is the optimal pressure. When the foam is too high, decrease the pressure; when spitting/popping is an issue, increase the pressure.

UNIT INSTALLATION

1. With countertop ready, place the dispenser in the desired location.
2. Install Selectable Ice / Flavor Magic Module.

Selectable Ice Module

The Selectable Ice Module will not be installed on the dispenser when unit is unboxed.

- A. Locate the Selectable Ice Module box in the dispenser bin and remove the module from the box.
- B. Remove merchandiser from dispenser by taking out the two screws located at the top of the merchandiser. Once the screws are removed rotate the top of the merchandiser towards you and then lift the merchandiser up to remove from unit.

- C. Remove the valve covers from the two valves next to the rocking chute.



Figure 1

- D. Loosen the two slotted knurl screws located on the valve mount cap.
- E. Hang the Selectable Ice Module bracket over the valve mount cap, and secure to the valve mount cap by tightening the knurl screws.



Figure 2

- F. Connect the wiring harness to the Selectable Ice Module (Figure 3) and locate the wire harness in the plastic clip as seen in figure 4.



Figure 3



Figure 4

- G. Loosen the bracket adjustment screws and pull the module toward you. This will allow for reinstallation of the merchandiser.



Figure 5

- H. Install merchandiser and adjust the Selectable Ice Module so that it is flush with the front of the merchandiser. Tighten the adjustment screws.



Figure 6

NOTE: If the equipment being installed has the Flavor Magic option, follow the instructions in the Flavor Magic manual for installation of the front module and the remote box. Also use the Flavor Magic manual for programming and trouble shooting the Flavor Magic equipment.

3. Run the beverage lines and water lines; make sure to install the water connections to the proper inlets. Connection "A" comes from the brass carbonator pump and connection "B" is your plain water supply.
4. Install plumbing drains and insulate.
5. Fill bin with ice.
6. Set flexible manifold for correct drink settings.
7. Turn water supply on.
8. Purge air from the carbonator tank. Lift the pressure relief valve tab on the carbonator tank until water comes out of the relief valve.
9. Connect the pump deck control lead to the pump motor.
10. Connect power supply cords. (There are 2 cords that need to be connected to a 115V power supply.)
11. Brix beverage valves.

Important

When installing cold carbonated (Intelli carb) equipment, never put a tee for the plain water connection in the line from the pump deck to the cold plate. Putting a tee in the line will create service problems and bad drink quality.

PRE-MIX PRESSURES

Normal pre-mix pressure regulators must be set at 60 PSI. Diet pre-mix pressure regulators must be set at 40 PSI. If you are experiencing high foaming, decreasing the pressures may correct the problem. Spitting and popping usually requires slightly increasing the pressures. Pre-mix beverage valve pressures vary by type and manufacturer. Please consult the manufacturer of the valves you are using for specific instructions regarding operation of the valve.

COLD CARB AND AMBIENT SYSTEM PRESSURES

1. **Incoming tap water** - must be at a minimum dynamic pressure of 40 psi and maximum static pressure of 70 psi.

Important

If incoming water pressure is under 40 psi dynamic, a water booster is recommended. If incoming water pressure is over 55 psi, a water regulating valve is recommended.

NOTE: For water booster setups, connect directly to the incoming water to the unit. A regulator may be needed to maintain 40 - 55 psi to the carbonator or water may be routed around the booster to the carbonator. If water pressure is too high to the carbonator poor drink carbonation can result.

Important

Water boosters are preset to turn on at 65 psi and off at 85 psi.

2. BIB pressure gauge must be set for 75 psi or according to your line run.
3. Carbonator Pressure gauge (Use Preset Regulator):
 - Cold Carbonation set for 75 psi.
 - Ambient systems must be set at 90 psi to 105 psi.

NOTE: For models with flavor shots you want to achieve .5 oz (14.787 cc) a second dispense, adjust flow controls accordingly. See Section 3 for how to program the flavor shot dispense duration on models with this feature.

ADA KEY PADS

These instructions are for installations with this option.

1. Remove power from the unit.

Merchandiser Removal

2. Loosen the two knurled fasteners located in the top of the merchandiser that hold the merchandiser in place.
3. Remove the merchandiser by lifting up and tilting forward.

Splash Panel Removal

4. Remove the splash panel from the unit by removing the two (2) phillips head screws holding it in place.

ADA Wiring

5. Route the ADA ribbon cable under the drain pan.



6. Continue routing the ADA cable behind the valve mount cap on the left hand side of the unit.

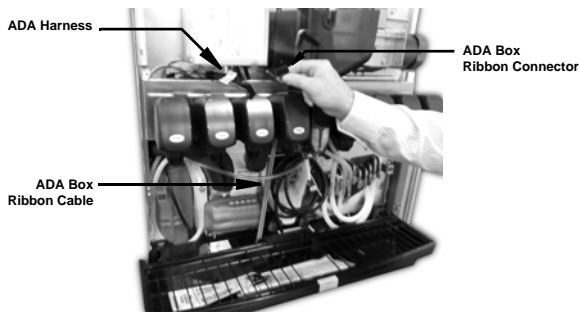

7. Connect the ADA ribbon cable to the ADA wire harness located to the left of the ice chute and held to the foam front by a wire clip.

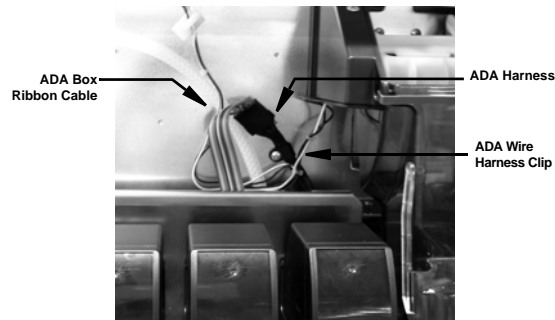

8. Neatly tuck in and take up any slack remaining in the ADA ribbon cable so it will not be in the way of any moving parts or panels when they are placed back on the unit.

Drain Pan & ADA Touch Pad Box

9. Attach the drain pan to the unit.
10. Center the ADA Key Pad Box with the unit in front of the drain pan and secure into place.

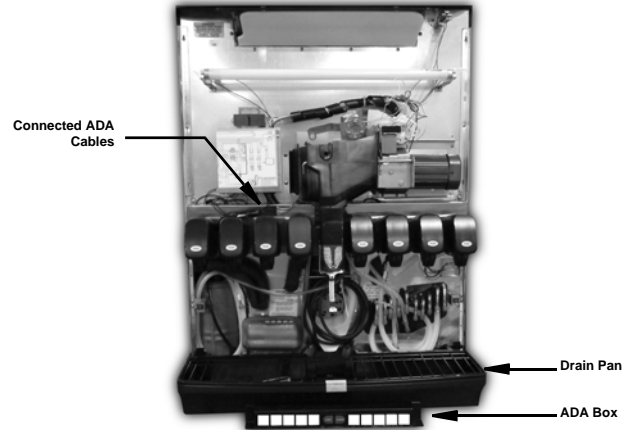

Important

If mounting the ADA Box directly in front of the drain pan on the counter top leave a minimum of 1 inch space between the bottom edge of the drain pan and the ADA Box to allow space for drain pan removal.

11. Apply corresponding drink labels to the ADA key pads.

NOTE: Drinks correspond from left to right on the left side of the unit, and right to left on the right side of the unit. If buttons are not used they will be blanked out. The Cubed/Crushed buttons are only utilized on units configured with the Selectable Ice feature. **(Figure)**

ADA Key Pad Matrix

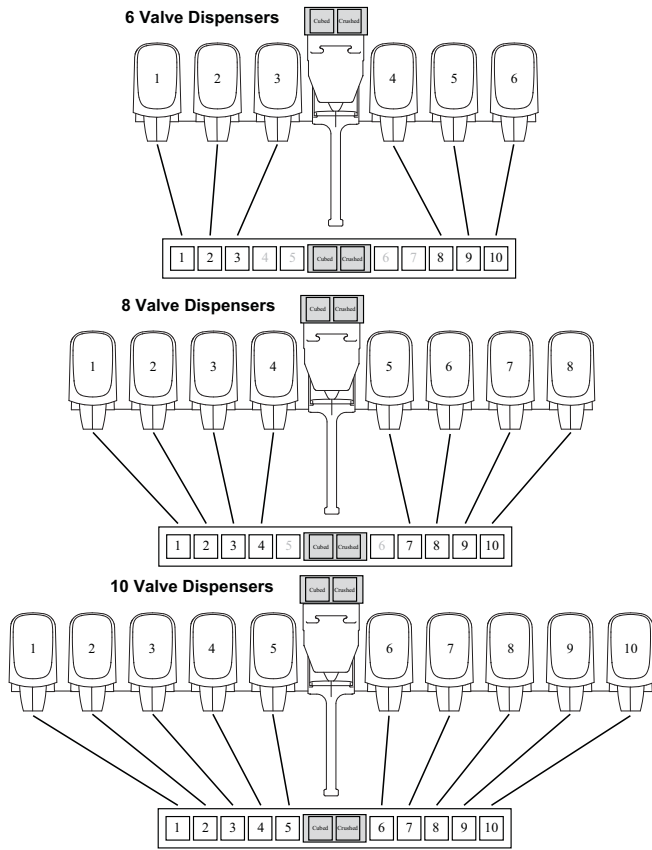

Starting Your Beverage System & Dispenser

Upon completion of the beverage dispenser and / or system installation, all tubing, dispenser, and system components must be cleaned and sanitized prior to use.

NOTE: At installation, equipment, dispensers, and tubing get moved through many environments, dirt, dust, chases, insulation, drywall, etc. It is an important procedure and best practice to address cleaning to deliver the best quality drink to your customer.

Important

Clean and sanitize the water and syrup circuits according to instructions provided in this manual. Clean and sanitize the dispenser components according to instructions provided in this manual. Seal to counter top when no legs are used with the unit. Consult and use local health codes if a discrepancy occurs between this manual and your local health codes.

Finish Installation

- Put the splash panel and merchandiser back onto the unit and reinstall the screws that hold them in place.



Restore power to the unit.

Section 3 Operation

General System Overview

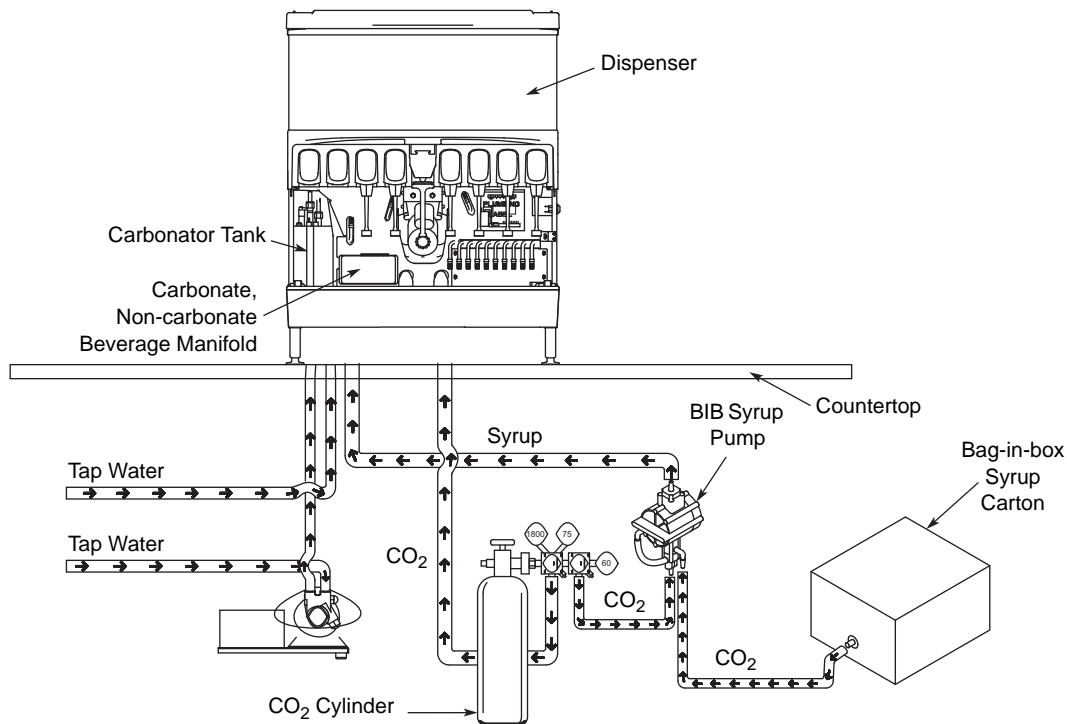

Typical Internal Carbonation Beverage Dispensing System

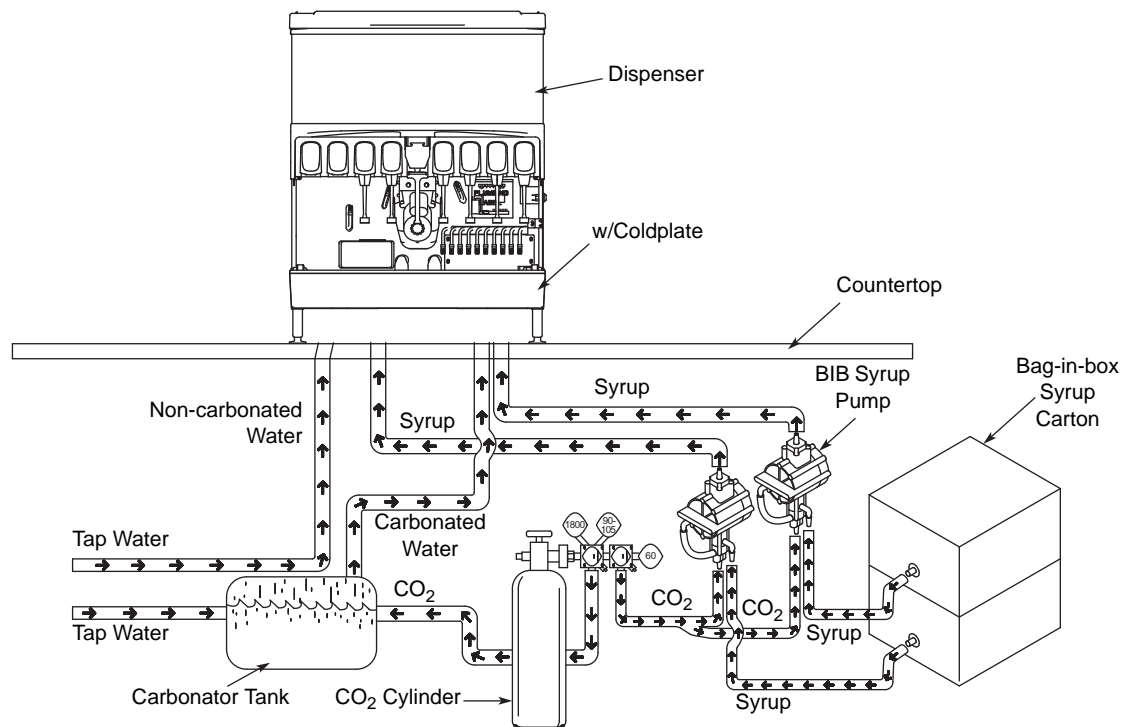

Typical External Carbonation (Ambient) Beverage Dispensing System

Component Identification

DISPENSER

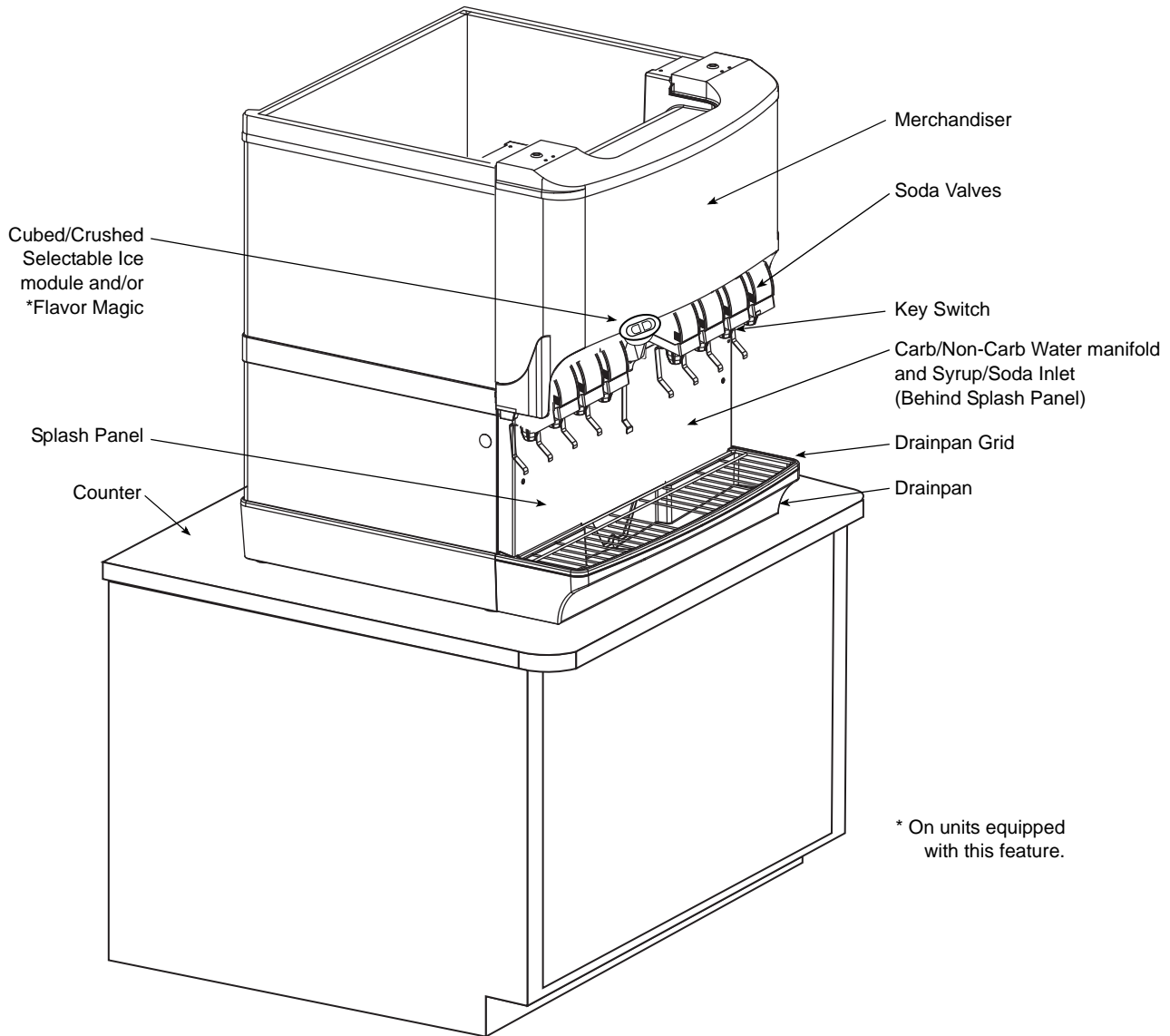

* On units equipped with this feature.

SELECTABLE ICE MODULE



SELECTABLE ICE MODULE WITH FLAVOR MAGIC



Sequence of Operation

ICE RECOMMENDED FOR DISPENSING

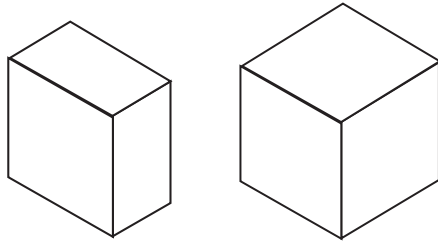

Half Dice
3/8" x 1-1/8" x 7/8"
(1.0 x 2.9 x 2.2 cm)

Half Dice
3/8" x 1-1/8" x 7/8"
(1.0 x 2.9 x 2.2 cm)

Dispensers are designed to dispense hard, cube ice up to one-inch square. The ice shapes and sizes listed above are recommended for dispensing. Warm "Super Cooled" Ice Before Dispensing: "Super Cooled" ice is not recommended for dispensing. "Super cooled" ice is ice that has been stored in freezers below 32°F. Should it be necessary to temporarily use "super cooled" ice, allow the ice to warm at room temperature for 25 to 30 minutes before placing the ice in the dispenser.

Flake or "nugget" ice is NOT to be dispensed from the Selectable Ice Unit. The SV Selectable Ice dispenser comes equipped with the selectable ice feature so you are able to choose between cubed or crushed ice making the addition of a flake/nugget icemaker unnecessary.

ICE STORAGE AND DISPENSING

As the customer presses the rocking chute, the arm at the top left rear of the chute pushes upward on the door lock. The door opens until it contacts the stops in the mounting brackets. The plastic arm on the ice chute also activates the lever of the ice dispensing switch. When activated, the micro switch starts the gear motor. The gear motor turns the paddle wheel and agitator arm.

The paddlewheel carries ice. Periodic agitation is standard on the 30" and larger dispensers. During periodic agitation, the paddle wheel and agitator turn for approximately three seconds every three and one half-hours. The door lock prevents ice from being dispensed during the agitation cycle.

SELECTABLE ICE SEQUENCE OF OPERATION

On units equipped with the selectable ice option, as a customer presses the ice chute or pushes the sanitary lever towards the unit with their cup, with "Crushed Ice" selected on the ice selection pad, the rocking chute door lifts and actuates micro switch which initiates the crushed ice dispensing process. The micro switch is activated when the lever is approximately 1/4 inch from reaching the splash panel of the unit. When activated, the micro switch starts the gear motor and ice crusher motor.

The gear motor turns the paddle wheel and U-bar agitator. The paddle wheel carries ice to the crusher assembly. Once the ice reaches the crusher housing, four stationary blades and three rotating blades crush the ice and push it through the opening in the ice crusher housing. The crushed ice then falls through the opening into the ice chute, and into the customer's cup. If the merchandiser is removed no power is available to the crusher or gear motor and no ice can be crushed and/or dispensed.

BEVERAGE VALVES

Post-mix beverage valves are designed to precisely meter the flow of both water and syrup to obtain the proper mixing ratio. The syrup and soda water components of the post-mix beverage are mixed as they leave the beverage valve.

CARBONATION

The purpose of the carbonator is to take regular tap water at street water pressure (minimum 20 PSI, maximum 80 PSI, dynamic or flowing pressure) 1/2" water line and increase the water to beverage system pressure (usually 100 PSI). This water is then combined with the CO₂ gas. Because the water and gas are at the same pressure, the CO₂ will dissolve into the water. Chilling the mixture before dispensing will assist in locking the carbon dioxide into the water. After dispensing, the CO₂ may be unlocked from the liquid. The CO₂ will gradually leave the liquid due to pressure and temperature changes.

Components

The components of the carbonator are: water pump, an electric motor to operate the pump, carbonator tank where the water and CO₂ mix, and a water level control.

Operation

Carbon Dioxide (CO₂) leaves the storage tank and arrives at the carbonator tank through the gas inlet. Water supply enters the carbonator pump inlet at regular street water line pressure (minimum 20 PSI, maximum 80 PSI, dynamic or flowing pressure). The water pump increases the pressure of the water, which allows the water to flow into the carbonator tank. The CO₂ and the water mix together in the carbonator to produce the carbonated water that is then sent to the soda dispenser.

The agitation of the water and CO₂ together in the tank under high pressure creates the soda water. The quality of carbonation (percent of CO₂ mixed in the water) increases as the water temperature decreases and exposure time increases.

The water level in the carbonator tank is controlled by a water level control in the tank. This control turns the pump motor off and on to maintain a preset level of liquid in the tank. The water level control may be electronic probes or a mechanical float.

SYRUP DELIVERY SYSTEM

Your syrup location can vary depending on the volume of beverages served and ease of accessibility. Your beverage system may set in a back storage room or under the counter of the dispenser. Configurations are almost limitless. Check the temperatures expected for the storage location. Adverse temperatures can affect the storage and quality of beverage products. It is recommended the temperature of storage location must not fall below 40°F (4°C) or rise above 90°F (32°C).

BACK ROOM PACKAGE

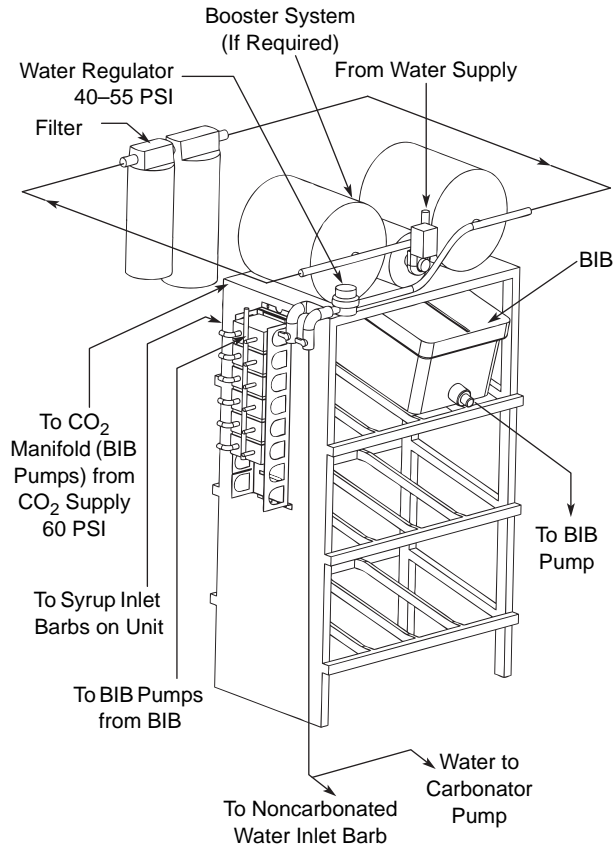

- Incoming tap water** – must be at a minimum dynamic pressure of 40 psi and maximum static pressure of 55 psi.
- Carbonator Water pump motor** – Powers the water pump. The water pump motor is part of the carbonator pump deck.
- Carbonator Water pump** – Pumps tap water into the carbonator tank. The water pump is part of the carbonator. The incoming water for the carbonator must be first run through the pump before connecting to the proper cold plate inlet.
- Internal/External Carbonator tank** – Combines CO₂ gas and tap water to form carbonated water. The “carbonator” is the carbonator tank, water pump and water pump motor.

- CO₂ cylinder** – Holds highly pressurized carbon dioxide (CO₂). The CO₂ cylinder is a steel or aluminum cylinder tank. CO₂ gas flows through the primary pressure regulator.
- BIB pressure gauge** – Set for a minimum of 60 psi. Indicates CO₂ pressure going to B-I-B pumps.
- Primary pressure regulator** – Lowers the CO₂ gas pressure, to 100 psi, so the CO₂ gas will be at the proper pressure to enter the carbonator regulator.
- Lowered outgoing pressure** – Set for 75 psi. Gauge indicates lowered outgoing pressure from the CO₂ cylinder after being routed through the primary pressure regulator at 100 psi.
- Secondary pressure regulator** – Lowers the CO₂ gas pressure before the CO₂ gas flows to the syrup pump. CO₂ pressure activates the syrup pump.
- Syrup pump** – Draws syrup out of the bag-in-box syrup package. Syrup flows through the syrup lines to the dispenser for chilling, then dispensing. There is a syrup pump for each bag-in-box syrup system.
- Bag-In-Box syrup cartons** – Box which contains a plastic bag, filled with syrup.

RACKING

Regardless if you are working on a B-I-B or Figal system, a place will be designated for placement of the product. A rack (or shelf) system affords systematic placement and complete usage of the beverage paid for. The B-I-B rack allows the boxes to lay properly for syrup dispersal. Please check with your B-I-B syrup supplier. Some boxes must be slightly tilted down, while others may be in virtually any position. The Figal tank rack keeps the newer and full tanks organized at one end of the beverage line with the partial tanks at the other.

B-I-B

The Bag-In-Box system refers to a plastic disposable bag. The B-I-B normally contains 5 gallons of syrup, however some locations offer 2-1/2 gallon B-I-B units. This plastic bag is then held inside a cardboard or other container. B-I-B systems are for post-mix applications only.

PUMPS

The syrup in a B-I-B system is delivered to the beverage system through gas operated pumps. These pumps extract the syrup out of the bags, forcing the syrup throughout the system.

AUTO BAG SELECTORS

These are used on higher volume B-I-B systems where two or more bags of the same product are connected to one pump and one system. An auto bag selector is essentially a valve that automatically changes from one bag (or series of bags) to another bag (or series of bags) of syrup as the bags empty, allowing a constant flow of product.

FIGAL SYSTEM

Figal refers to the stainless steel tanks of pre-mix beverage or post-mix syrup. A small CO₂ tank pushes the beverage out of the figal tank.

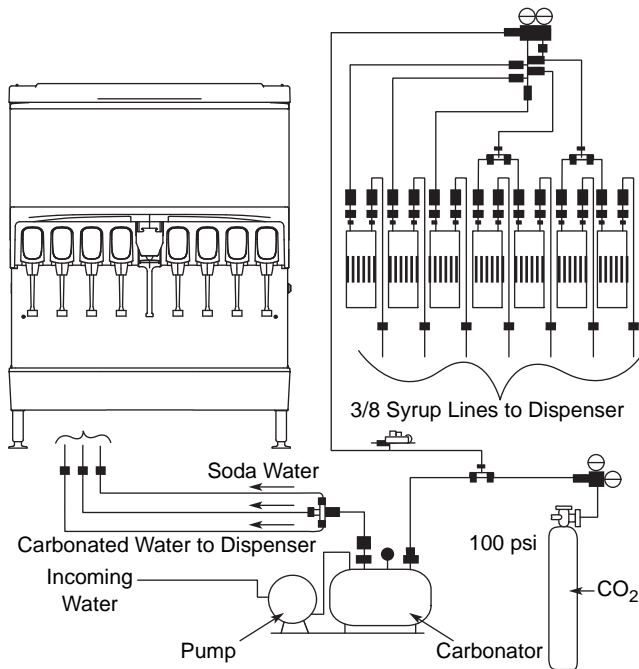

FIGAL TANKS

The stainless steel Figal beverage tanks are easy to store and connect. When using the Figal tanks:

- Use a gas connector for the inlet fitting of the tank.
- Use a syrup connector for the outlet fitting of the tank.
- If more than one Figal tank is connected in series, when changing tanks, remove the tank closest to the original gas inlet while adding the new tank to the connector closest to the syrup outlet.

Most Figal tanks have a self-closing valve on the tank as well as the gas and syrup connectors. This allows the operator of the system to change tanks without having to shut down the entire system. With this type of connector, push down on the connector while pulling up on the **snap ring** around the opening of the connector. Then simply pull the connector off the tank.

Programming Modes

SELECTABLE ICE NON-ADJUSTABLE AGITATION

On units equipped with the selectable ice option, timed agitation for the unit is handled by the control board and is not adjustable.

NOTE: This timer is re-settable, timed agitation every 3.5 hours from last dispense or when the power supply is broken.

CRUSHED OR CUBED DEFAULT

This selectable ice option will allow the unit to always default to either cube or crushed ice or remain at the last selection. This only applies to control boards 020000875 Rev 7 and up.

How to set default ice dispense setting

CUBED DEFAULT

1. Power on the unit by plugging in receptacle and holding the cube button at the same time, cube will flash 2 times. Unit will now change to cube 10 seconds after crush is selected and/or used.

CRUSHED DEFAULT

2. Power on the unit by plugging in receptacle and holding the crushed button at the same time, crush will flash 2 times. Unit will now change to crush 10 seconds after cube is selected and/or used.

LAST SELECTION DEFAULT

3. Power on the unit by plugging in receptacle and holding cube and crush at the same time, cube and crush will flash 2 times. Unit will now remain in selection of last request.

NOTE: If power is lost to the unit and then powered up again the unit will retain the last setting and not return to factory settings.

AGITATION TIMER OPERATIONAL CHECK

Selectable Ice Modules have a Selectable (crushed & cubed) ice agitation timer test mode:

1. Press and hold "cubed" for over 1 second.
2. While holding "cubed", press "crushed" three (3) times, all led's will flash indicating test mode.
3. While in the test mode, the agitator motor will cycle three (3) times, 3 seconds ON and 10 seconds OFF.
4. After the test mode is complete the unit will automatically reset to the run mode.

NOTE: To disable the test mode before the three (3) cycles are complete, press the "cubed" button.

FLAVOR MAGIC MODES

For Units With This Option

The program mode can only be accessed by pressing the program button during the first five seconds of initial power up. To exit the program mode at any time hold the program button for >3 seconds and the controller will switch to the dispense mode.

PROGRAM DISPENSE TIME

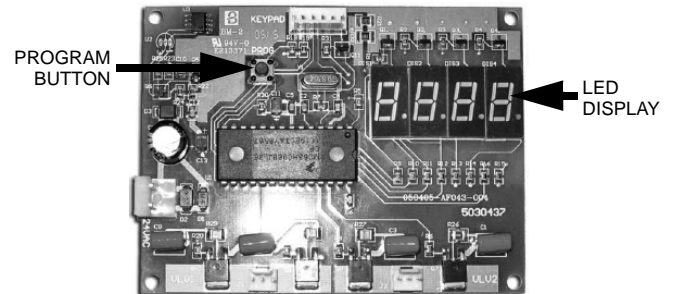

1. The program mode is used to adjust the dispense time. To access the Program Mode, disconnect power to the control board, wait ten (10) seconds and reconnect power.
2. Press the program button one time on the control board during the first five (5) seconds after power is applied.
3. The LED display will show "P r o". To check the current dispense time, press the corresponding flavor button on the touchpad and the time will be displayed on the LED (Example "1.0").
 - a. To increase the time (+) by two-tenths (0.2) second increments press flavor button 1 (far left button). To decrease the time (-) by two-tenths (0.2) second increments press flavor button 3 (far right button). The default setting is one (1.0) second.

PURGE / SANITIZE

1. Purge/Sanitize mode allows the user to purge air from the syrup lines during initial start-up. The second function of this mode is to energize the valves to move sanitizer through all syrup lines automatically.
2. Enter the Purge/Sanitize Mode by press the program button until "P - S" is displayed.
3. Pressing flavor button 1 (far left button) will activate a sequenced four (4) second dispense that starts with flavor 1 then to flavor 2 etc. The valves will continue to cycle for 15 minutes or until the program button is pressed once.

FLAVOR MAGIC DISPENSING MODES

For Units With This Option

Normal Dispense

With power applied to the control board, it will automatically start in dispense mode after a five (5) second delay. The LED display will count down from four (4) to zero (0) and then show “- - -” while in dispense mode. Simply pressing the desired flavor on the touchpad dispenses Flavor Magic.

Flavor Counter

The flavor counter tracks the number of flavor shots dispensed per flavor. To access Flavor Counter Mode, press the program button on the control board once for at least three (3) seconds. The LED display will show “C n t”. In the count mode the Flavor Magic module will not dispense.

Check the number of dispenses for any flavor by pressing the corresponding touchpad button. To check another flavor press the program button once and then the corresponding flavor button on the touchpad. To return to dispense mode press the program button until the LED display shows “- - -”.

CHANGING NUMBER OF ACTIVE FLAVORS

To line up flavors with valves, note that valve outlets number from left to right 1...2...3...4. Touch pad flavor tab is numbered as shown below. Connect vinyl tube from outlet 1 and dispense with flavor tab 1, etc..



The current Flavor Magic control board is set up in the 4 flavor default mode. This mode will handle all dispensing situations whether 3 or 4 flavors are used. Some early boards were set up as default in the 3 flavor mode. If the customer desires to add another flavor for a total of 4, proceed as follows:

1. Power down the circuit board by disconnecting the 24 volt connector in the lower left hand side of the board. “24VAC” is imprinted on the board next to the pin connection.
2. Wait a minimum of 10 seconds.
3. Power up the board by connecting the 24 volt connector.
4. IMMEDIATELY (within 5 seconds) press and hold the “PROG” button down.
5. After a few seconds, the number “4” will appear on the display.
6. Release the “PROG” button. The board will cycle the display from “Pro” to “4.....3.....2.....1.....0” and then to “- - -”.
7. The circuit board is now enabled to dispense the 4th flavor. The 4th flavor button is the top middle button.
8. A flavor tab for the 4th flavor will have to be added to the touch pad. To do this, obtain one (1) P/N 5030780 20 flavor decal pad. Remove the P/N 5031579 decal overlay and add the 4th flavor tab as well as replace any flavor tabs which came off when removing the decal overlay.
NOTE: Position of 4th flavor on the touch pad in the picture and placed tab where indicated.
9. Obtain a new P/N 5031579 decal overlay and place over the tabs.

If the customer decides to go back to 3 flavors, it will not be necessary to change the board back to 3 flavors. However, it can be done by following steps 1 through 6 above. The number “3” will appear on the display. Then disconnect the number “4” syrup from the system, remove the 5031579 decal overlay, remove the flavor tab “4” and replace the 5031579 decal overlay.

NOTE: It would be a good idea to have an additional P/N 5030780 in case flavor tabs are damaged in the process.

TIME DELAY AFTER DISPENSE

1. A time delay can be programmed into the control board which will prevent the system from dispensing another flavor for a period of from 0 to 10 seconds following a dispense. The default is 0 seconds.
2. Enter the Time Delay mode by pressing the program button until “d L A Y” is displayed. To check the current delay time press any flavor button one time and the current value will be displayed. To increase the time (+) by 1.0 second increments press flavor button 1 (far left button).
3. To decrease the time (-) by 1.0 second increments press flavor button 3 (far right button). When done move on to another programming mode or if you are finished return the control board to the dispense mode by pressing the program button and holding for 3 seconds or until the LED displays 0.

THIS PAGE INTENTIONALLY LEFT BLANK

Section 4

Maintenance

Preventive Maintenance

Preventative maintenance is a vital part of keeping your dispenser in top condition. Following the guidelines below will assist you in continued trouble-free operation of your unit.

1. Conduct daily maintenance of the unit. On units equipped with Flavor Magic, clean the nozzle and retainer area to prevent syrup buildup by doing the following:
 - a. Fill a small cup with warm to hot water.
 - b. Immerse the nozzle area fully by drawing the cup up and around the nozzle.
 - c. Allow syrup to dissolve into the water. Change the water several times to assure the syrup is removed.
 - d. Discard water.
2. Perform monthly maintenance of the machine.
3. After each removal from an empty bag and prior to placing connector on new bag clean BIB connectors to prevent syrup residue by doing the following:
 - a. Prepare a bucket of warm to hot water.
 - b. Submerge connector in water until residue is dissolved.
 - c. Place connector on new bag.
 - d. Discard water.
4. Perform periodic sanitizing of beverage system.
5. Do not overfill the dispenser bin with ice.
6. Do not allow the dispenser to sit for prolonged periods of non use with ice in the bin.
7. Most ice dispenser service problems are caused by low usage of the ice dispenser.
8. Do not allow ice to remain in the bin more than a day in order to prevent ice from freezing together and/or stagnant ice.

Possible excess ice storage reasons:

- Storage capacity exceeds daily requirements.
- Low demand during the off season.
- Dispenser oversized with future growth in mind.

Lower ice storage to meet one day's needs. If you manually fill ice, fill only with the appropriate amount of ice. Fill the dispenser with fresh ice each morning. Do not fill the dispenser at night just before shut down. Ice cubes can freeze together if not dispensed.

Contact MBE at 1-800-367-4233 for more information about our ProActive Maintenance Program.

Cleaning

DAILY CLEANING

All cleaning must meet your local health department regulations. The following cleaning instructions are provided as a guide.

Caution

Use only warm soapy water to clean the exterior of the tower. Do not use solvents or other cleaning agents. Do not pour hot coffee into the drain pan. Pouring hot coffee down the drain pan can eventually crack the drain pan, especially if the drain pan is cold or still contains ice.

Warning

Electric Shock Hazard

Unplug unit before servicing or cleaning.

Warning

When using cleaning fluids or chemicals, rubber gloves and eye protection must be worn.

Exterior & Drain Pan

1. Turn off the key switch located on either right or left side of the unit.
2. Lift the grid and remove it from the drain pan.
3. Using mild soap, warm water and a clean cloth, wipe the drain pan and splash panel. Then, rinse with clean, warm water. Allow plenty of warm (not hot) water to run down the drain of the drain pan, to remove syrup residue that can clog the drain opening.
4. Wash the grid, then rinse with clean water. Place the grid back in the drain pan.
5. Wash all exterior surfaces of the unit with warm water and a clean cloth. Wipe again with a clean, dry cloth.

Cleaning Checklist

- Check CO₂ supply. If CO₂ supply is low, an arrow on the primary regulator gauge will point to a shaded area that reads "Low CO₂" or "Change CO₂ Cylinder."
- Check syrup supply.
- Clean drain pan, grid, and splash panel.
- Clean the nozzles.

Dispensing Valves

1. Remove nozzles and diffusers from beverage valves.

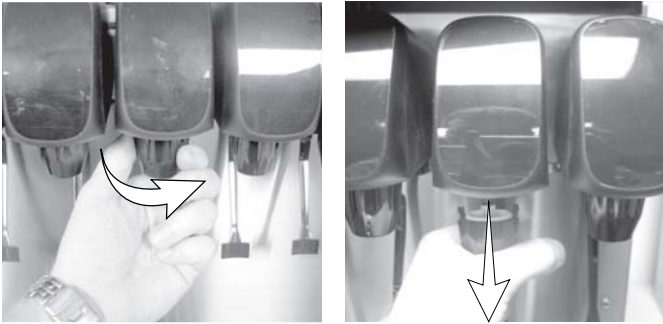

Nozzle Removal

2. Rinse nozzle and diffuser with warm, clean water.
3. Clean nozzles and diffusers with soapy water and a soft bristle brush.
4. Clean the underside of the beverage valves with warm, soapy water. Rinse with clean damp towel.
5. Replace nozzles and diffusers on valves.
6. Turn on the key switch.

MONTHLY CLEANING

Caution

Unplug unit before servicing or cleaning ice bin.
Ice bin contains parts that can move at any time and will cause injury if hands are in the way.

Warning

When using cleaning fluids or chemicals, rubber gloves and eye protection must be worn.

Ice Bin

1. Unplug unit and remove all ice from the ice bin.
2. Mix a solution of mild detergent to clean the dispenser bin and components.
3. Wash the ice bin using a sponge and the mild detergent solution.
4. Using the mild detergent solution and a soft bristle brush or clean cloth, clean the following bin and selectable ice components;

Bin components:

- Entire bin
- Paddle wheel
- Paddle wheel area
- Agitator
- Paddle wheel pin
- Ice Chute
- Rear bushing
- Motor shaft
- Strip lids (where applicable)

Selectable Ice Components:

- Decorative Chute
- Housing
- Housing Door
- Whole Ice Door
- Sanitary Lever
- Hub/Blade Assembly
- Drip Pan

5. Rinse all the parts in clean, running water.
6. Prepare 2 gallons of sanitizing solution by mixing 1/2 ounce of household bleach (that contains 5.25% sodium hypochlorite) with 2 gallons of 120°F water. The mixture should not exceed 100 PPM of chlorine. Or mix a solution of any approved sanitizer, following the directions for mixing and applying the sanitizer.
7. Sanitize the ice bin and cold plate with the sanitizing solution for at least 10 seconds.
8. Allow to air dry. Do not rinse.
9. Re-assemble all bin and selectable ice parts once dry and hand tighten all knurled fasteners.
10. Pour in fresh, sanitary ice and replace the plastic lid on the top of the dispenser.
11. Plug in the unit's electrical cord.
12. Check for proper ice dispensing.

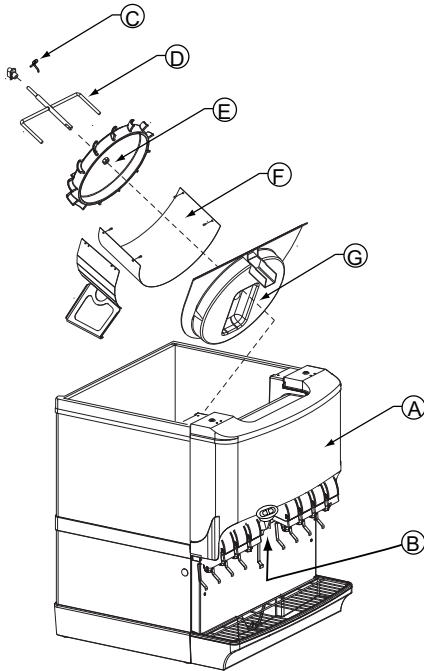

Disassembly

FOR CLEANING & MAINTENANCE

NOTE: Sanitize the ice dispenser at Initial Start-up in addition to monthly sanitizing. You will need a slotted [screwdriver](#) in order to disassemble.

Disassemble parts in the following order:

- A. Merchandiser
- B. Selectable Ice chute
- C. Hitch Clip Pin
- D. Agitator
- E. Paddle wheel
- F. Bin liner
- G. Paddle wheel area

Accessing a Dispenser Bin Top Mounted with a Manitowoc ice machine:

1. Remove the front panel of the ice machine.
2. Remove the ice deflection baffle. This will give you access to the dispenser bin.
3. If the Manitowoc ice machine is operating, wait for the sheet of ice to fall into the dispenser bin.

When the ice sheet falls into the dispenser bin, immediately place toggle switch of the ice machine to the OFF position. If the Manitowoc ice machine is NOT operating, place the toggle switch of the ice machine to the OFF position.

4. On models without a top mounted ice machine, remove the plastic lid from the top of the dispenser.
5. Remove all ice from the dispenser.
6. Disconnect electrical power to the dispenser.
7. Remove agitator arm and paddlewheel pin.

Front Serviceable Motor

- a. With agitator arm in any position remove hitch clip pin from the mushroom bushing on the rear of the ice bin.
- b. Push the agitator bar toward the bushing to remove it from the paddle wheel hub.

NOTE: If a top mount ice machine is installed, sliding the ice machine to one side will make bin component removal easier. If the ice machine is hard plumbed it will need to be disconnected.

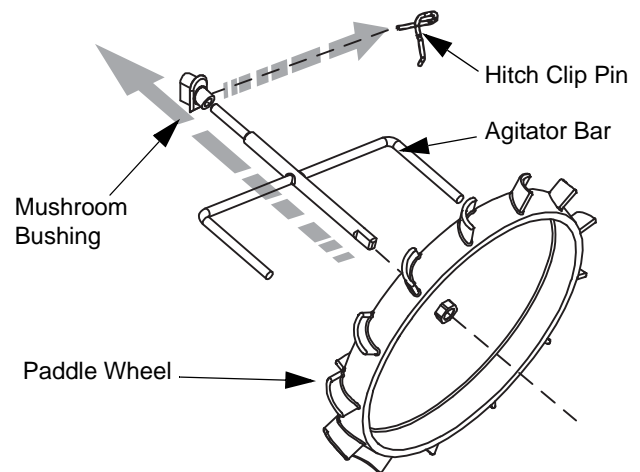

Front Serviceable

8. Remove paddle wheel, bin liner and paddle wheel area.
9. Move the front of the agitator to one side and slide the agitator forward until the rear of the agitator shaft is clear of the bushing.
10. Remove the agitator from the bin area.
11. Slide the paddle wheel from its shaft.
12. Loosen 4 knurled fasteners that hold the bin liner in place.
13. Remove the bin liner.
14. Remove the paddle wheel area from the bin.
15. Discard the remaining ice in the bin.

SELECTABLE ICE CRUSHER

Once the ice crusher hub assembly has been removed the crusher is ready to be cleaned and sanitized. Follow the steps below for proper cleaning and sanitizing procedures.

1. Assure the unit is unplugged.
2. Mix a solution of mild detergent to clean the ice crusher components.

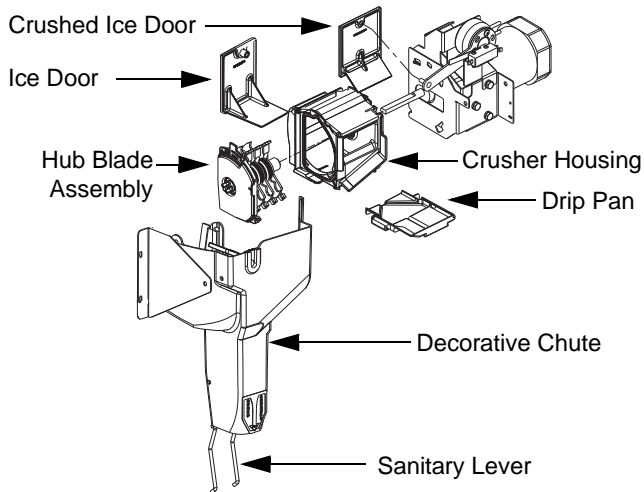

3. Using the mild detergent solution and a soft bristle brush or clean cloth, clean the following ice crusher components.

- Blade / Hub assembly
- Cosmetic Chute
- Drip Pan
- Crusher Housing
- Ice Crusher Motor Shaft
- Ice Door
- Crushed Ice Door

4. Rinse all of the parts with clean water.
5. Prepare 2 gallons of sanitizing solution by mixing a ½ ounce of household bleach (that contains 5.25% sodium hypochlorite) with 2 gallons of 120 F water. The mixture should not exceed 100 PPM of chlorine. Or mix a solution of any approved sanitizer, following the directions for mixing and applying the sanitizer.
6. Apply sanitizer to all parts with clean cloth, or by spraying.
7. Allow to air dry. DO NOT RINSE.
8. Reassemble the Ice Crusher Assembly by following the instructions in the "Reassembling the Ice Crusher Assembly" section.

REASSEMBLE THE ICE CRUSHER ASSEMBLY

1. Insert the blade assembly into crusher housing. When inserting blade assembly you must align the stationary blades with the locating slots in the crusher housing.

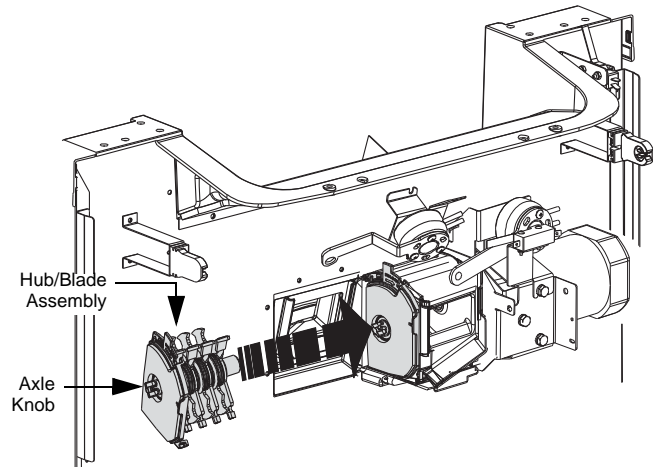

2. When inserting the blade assembly into the crusher housing you must also make sure the axle knob is in a vertical position. This will align the rotating blades with the housing to assure a quick and easy installation.
3. Once all blades are in the housing you will need to align the crusher axle with the motor shaft. You can do this by turning the axle knob and pushing the blade assembly toward the motor until the crusher hub is flush with the end of the housing.
4. To lock the blade assembly into the housing rotate the crusher hub counter clockwise until the locking tab snaps into place and the crusher hub is secure.

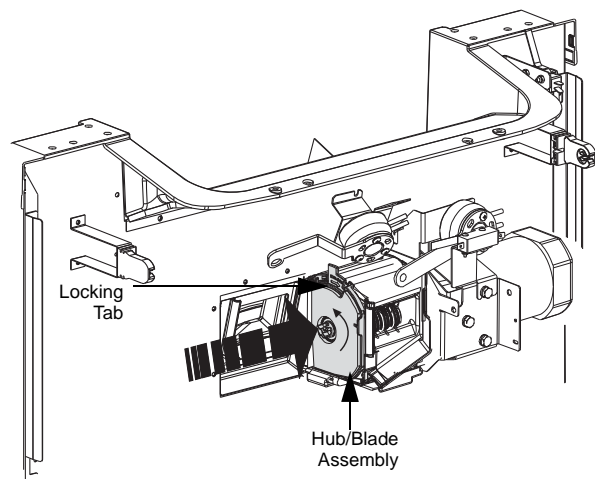

5. Replace the ice door, crushed ice door, and crusher drip pan, slide until it snaps into place.

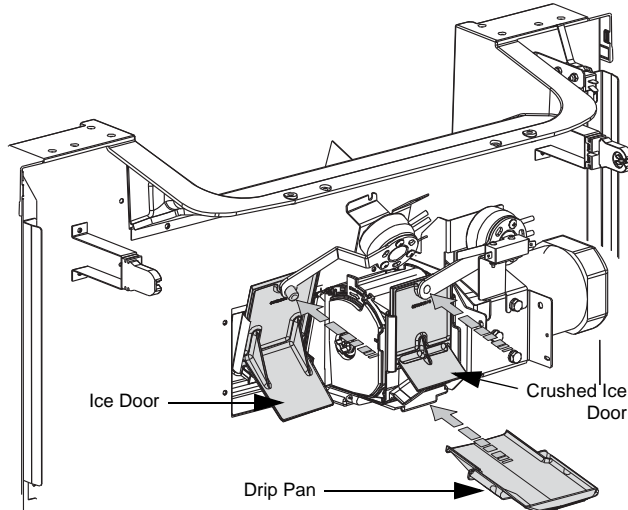

6. Reattach the decorative ice chute by inserting the chute rod through the chute, housing mount, and motor mount. secure the chute rod by inserting the cotter pin through the rod on the right side of the housing mount. Make sure arm of microswitch is in front of vertical protrusions on top of decorative chute.

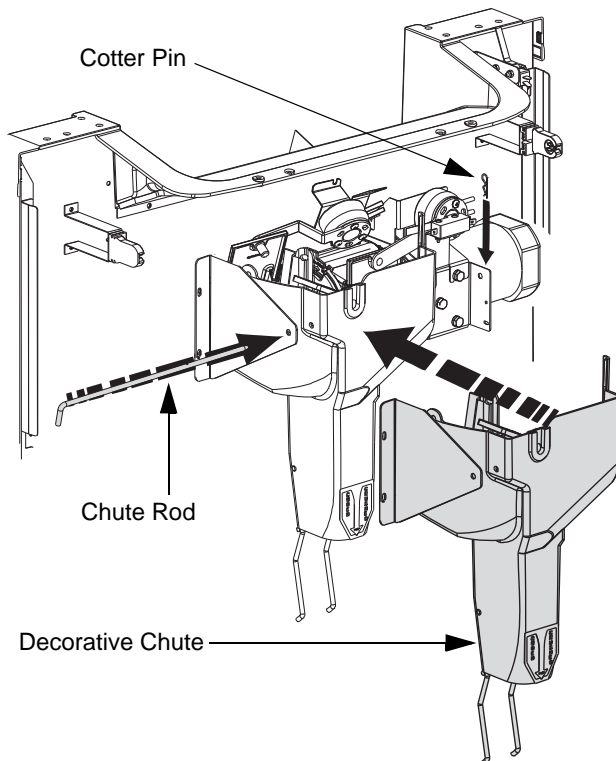

7. Reinstall the merchandiser, and secure with the two (2) screws that were removed during disassembly.
8. 110V power may be reapplied when unit is completely reassembled.

FRONT SERVICEABLE GEAR MOTOR REMOVAL

These instructions are provided as a guide for the removal of the gear motor. Depending on the model number of your dispenser, these instructions may vary slightly.

1. Unplug the dispenser.
2. Unplug the motor.
3. Remove motor mount pins.

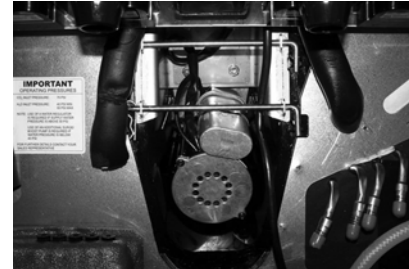

4. Slide motor towards you, notice alignment of the chamfered edge of drive shaft.



5. New motor must have the same alignment (within 15 degrees).
6. To get correct alignment you can do one of two things:
 - a. Turn drive shaft with an adjustable wrench, being careful not to damage the drive shaft.
 - b. Plug in the unit, plug in the motor and use the ice dispense switch to move the drive shaft into correct alignment.
7. If you plugged in the unit to help with alignment of drive shaft now unplug the unit.
8. Slide motor up into housing, making sure that the tabs fit on the bracket.



9. Install motor mount pins.
10. Plug in motor.
11. Test unit.

Sanitizing

BEVERAGE SYSTEM CLEANING

Warning

Flush sanitizing solution from syrup system.
Residual sanitizing solution left in system could create a health hazard.

Warning

When using cleaning fluids or chemicals, rubber gloves and eye protection must be worn.

Sanitize the beverage system at initial start-up as well as regularly scheduled cleaning. The drain pan must be in place under soda valves, to carry away detergent and sanitizing agents that will be flushed through valves.

BAG-IN-BOX SYSTEM SANITATION

The procedure below is for the sanitation of one syrup circuit at a time. Repeat to sanitize additional circuits.

You will need the following items to clean and sanitize the Bag-in-Box (BIB) beverage system:

- Three (3) clean buckets
- Plastic brush or soft cloth
- Mild detergent
- Unscented bleach (5% Na CL O) or Commercial sanitizer
- Bag-In-Box bag connector

1. Prepare the following in the buckets:

- Bucket 1 — warm to hot tap water for rinsing.
- Bucket 2 — mild detergent and warm to hot water.
- Bucket 3 — mix a solution of unscented bleach (5% Na CL O) or commercial sanitizer and warm to hot water. Mixture must supply 100 PPM available chlorine (1/4 oz. bleach to 1 gallon water).

2. Disconnect the “syrup-line side” of the bag-in-box connector.

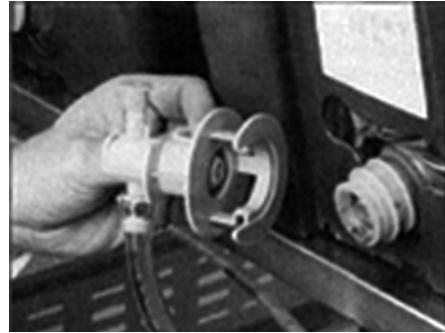

3. Rinse connector with warm tap water.

4. Connect syrup connector to BIB connector and immerse both into Bucket 1. A “bag-side” connector can be created by cutting the connector from an empty disposable syrup bag.

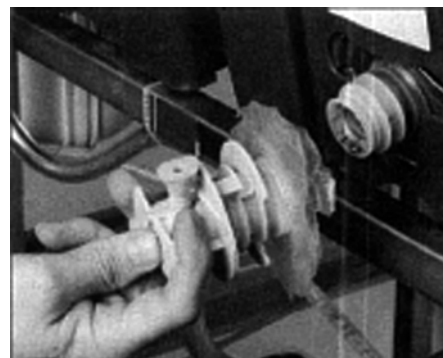
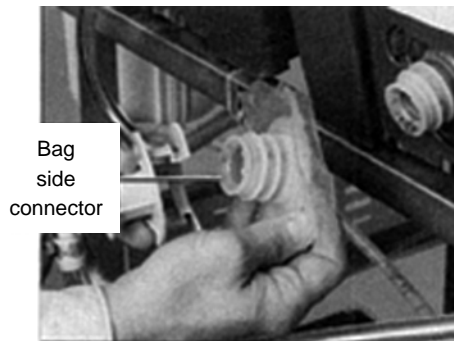

5. Draw rinse water through system until clean water is dispensed. Most beverage valves allow the syrup side to be manually activated by depressing the syrup pallet.
6. Connect Bucket 2 to system.
7. Draw detergent solution through system until solution is dispensed.
8. Repeat steps 2-7 until all syrup circuits contain detergent solution.
9. Allow detergent solution to remain in the system for 5 minutes.
10. Connect Bucket 3 to system.
11. Draw sanitizing solution through system until solution is dispensed.
12. Repeat step 11 until all syrup circuits contain sanitizer solution.
13. Allow sanitizer solution to remain in system for 15 minutes.
14. Remove nozzles and diffusers from beverage valves.
15. Scrub nozzles, diffusers and all removable valve parts (except electrical parts) with a plastic brush or a soft cloth and the detergent solution.
16. Soak nozzles, diffusers and removable valve parts (except electrical parts) in sanitizer for 15 minutes.
17. Replace nozzles, diffusers and valve parts.
18. Connect Bucket 1 to system.
19. Draw rinse water through system until no presence of sanitizer is detected.
20. Attach syrup connectors to BIBs.
21. Draw syrup through system until only syrup is dispensed.
22. Discard first 2 drinks.

FLAVOR MAGIC

For Units With This Equipment

BevClean™ Process

To efficiently clean entire dispensing circuit:

1. Hook up BevClean™ system per BevClean™ instructions.
2. Set Control Board to "Purge" mode. Press Flavor 1 tab to initiate "Purge" Cycle to draw BevClean™ into system. Allow cleaner to remain in system for five (5) minutes.
3. Disconnect BevClean™ system and reconnect disconnects to BIB's.
4. Set Control Board to "Purge" mode. Press Flavor 1 tab to initiate "Purge cycle to completely remove BevClean™ from syrup lines and vinyl tubing. (See PURGE/SANITIZE in the Programming Modes section)
5. Set Control Board to "Purge" mode. Press Flavor 1 tab to initiate "Purge cycle completely fill system with syrup.
6. Restore Control Board to "DISPENSE" mode. Dispense and discard sufficient samples to assure all BevClean™ is removed from system.

Conventional Clean/Sanitize Method

Important

When changing syrup boxes, immerse connector in warm water (100° F, 38° C - maximum temperature) to remove syrup residue. **RECOMMENDED SANITATION INTERVAL IS EVERY 90 DAYS**

Warning

Flush sanitizing solution from syrup system. Residual sanitizing solution left in system could create a health hazard.

Warning

When using cleaning fluids or chemicals, rubber gloves and eye protection must be worn.

Sanitize the beverage system at initial start-up as well as regularly scheduled cleaning. The drain pan must be in place under soda valves, to carry away detergent and sanitizing agents that will be flushed through valves.

Bag-In-Box System Sanitation

The procedure below is for the sanitation of one syrup circuit at a time. Repeat to sanitize additional circuits.

You will need the following items to clean and sanitize the Bag-in-Box (BIB) beverage system:

- Three (3) clean buckets
 - Plastic brush or soft cloth
 - Mild detergent
 - Unscented bleach (5% Na CL O) or Commercial sanitizer
 - Bag-In-Box bag connector
1. Prepare the following in the buckets:
 - Bucket 1 — warm to hot tap water for rinsing.
 - Bucket 2 — mild detergent and warm to hot water.
 - Bucket 3 — mix a solution of unscented bleach (5% Na CL O) or commercial sanitizer and warm to hot water. Mixture should supply 100 PPM available chlorine (1/4 oz. bleach to 1 gallon water).
 2. Disconnect the “syrup-line side” of the BIB connector.
 3. Rinse connector with warm tap water.
 4. Connect syrup connector to BIB connector and immerse both into Bucket 1. A “bag-side” connector can be created by cutting the connector from an empty disposable syrup bag.
 5. Set the Control Board to the “Purge” mode by pressing flavor button 1 (far left button) to activate a sequenced four (4) second dispense that starts with flavor 1 goes to flavor 2 etc. (The valves will continue to cycle for 15 minutes or until the program button is pressed once). (See PURGE/SANITIZE in the Programming Modes section)
 6. Draw rinse water through system until clean water is dispensed.
 7. Connect Bucket 2 to system.
 8. Draw detergent solution by activating “Purge” mode as described in step 5 and operating valves until detergent solution is dispensed.
 9. Allow detergent solution to remain in the system for 5 minutes.
 10. Connect Bucket 3 to system.
 11. Draw sanitizing solution by activating “Purge” mode as described in step 5 and operating valves until sanitizing solution is dispensed.
 12. Allow sanitizer to remain in system for fifteen (15) minutes.
 13. Remove the nozzle(s) and retainer(s) from the Flavor Magic Module(s) and scrub them with a plastic brush or cloth using the detergent solution.
 14. Soak plastic tubing ends at retainer in sanitizing solution for fifteen (15) minutes.
 15. Soak nozzle(s) and retainer(s) in sanitizer for fifteen (15) minutes.
 16. Replace nozzle(s) and retainer(s).
 17. Connect Bucket 1 to system.
 18. Draw rinse solution by activating “Purge” mode as described in step 5 and operating valves until rinse water is dispensed.
 19. Attach syrup connectors to BIB's.
 20. Draw syrup by activating “Purge” mode as described in step 5 and operate valves until only syrup is dispensed.
 21. Place Control Board in dispense (“- - -”) mode and operate each flavor three (3) times into a disposable cup.
 22. Discard the cup and contents. Shipping, Storage and Relocation

FIGAL BEVERAGE SYSTEM

1. Prepare the following in three clean Figal tanks:
 - **Rinse tank** - fill with room temperature tap water.
 - **Detergent tank** - mix approved beverage system cleaner with warm water as directed.
 - **Sanitizing tank** - mix a solution of unscented bleach (5% Na CL O) or commercial sanitizer and warm to hot water. Mixture must supply 100 PPM available chlorine (1/4 oz. bleach to 1 gallon water).
2. Disconnect all product and water lines from product tanks and remove carbonator.
3. Locate the Figal syrup tank for the circuit to be sanitized. Remove both quick disconnects from the Figal syrup tank. Rinse quick disconnects in tap water.
4. Connect rinse tank to the syrup line. Draw clean rinse water through the valve until syrup is flushed from the system.
5. Connect detergent tank to the syrup line and draw detergent through the valve for two minutes. Then, allow remaining detergent to stay in the system for five minutes.
6. Connect rinse tank to the syrup line. Draw clean rinse water through the valve until detergent is flushed from the system.
7. Remove valve nozzle and diffuser as shown in Daily Cleaning instructions. Using a plastic brush or a soft cloth and warm water, scrub the nozzle, diffuser, bottom of the dispensing valve and cup lever, if applicable.
8. Place removable valve parts (EXCEPT solenoids) in sanitizing solution for 15 minutes.
9. Replace valve diffuser and nozzle on the beverage valve.
10. Connect sanitizer tank to the syrup line and draw sanitizer through the valve for two minutes. Allow sanitizer to remain in the system for a minimum of 15 minutes.
11. Reconnect syrup and carbonated water lines.
12. Draw syrup through the lines to rinse the system. Discard drinks until at least two cups of satisfactory tasting beverage are dispensed through the valve.

Shipping, Storage and Relocation **Caution**

Before shipping, storing, or relocating this unit, syrup systems must be sanitized. After sanitizing, all liquids (sanitizing solution and water) must be purged from the unit. A freezing environment causes residual sanitizing solution or water remaining inside the unit to freeze, resulting in damage to internal components.

THIS PAGE INTENTIONALLY LEFT BLANK

Section 5

Before Calling for Service

Checklist

If a problem arises during operation of your dispenser, follow the checklist below before calling service. Routine adjustments and maintenance procedures are not covered by the warranty.

DISPENSER GENERAL

Problem	Possible Cause	To Correct
Dispenser will not dispense ice (and NO SOUNDS are heard when machine is activated).	No power.	Check electrical connection.
	Loose wire in electrical system.	Thoroughly check all wire connections.
	Dispenser overloaded with ice.	Remove ice from dispenser until unit will operate.
	Motor not working.	Check thermally protected motor. Replace motor or capacitor if necessary.
Dispenser will not dispense ice (motor runs but no ice movement is heard in bin).	No ice in bin.	Fill dispenser with ice.
	Door not opening.	Check rocking chute mechanism or electric solenoid operation.
	Paddle wheel pin slipped from the paddle wheel.	Replace paddle wheel pin.
Excessive clustering or bridging of ice.	Loaded ice not broken up. (Caution: Super cooled ice is not covered by the Servend warranty.)	Break ice clusters before manually filling the dispenser. (See ice recommendations.)
	Excessive water spilling from the ice machine.	Adjust ice machine to eliminate water spillage.
	Poorly adjusted ice machine.	Adjust ice machine to eliminate large waffle shapes.
	Extremely low usage of the dispenser.	Lower the ice level in the bin.
Ice dispenses continuously.	Misaligned microswitch.	Adjust microswitch.
	Agitation timer set incorrectly.	Test agitation timer.
Thumping noise or irregular sound at a particular area of the dispenser.	Shaved ice clusters in the bin.	Remove clusters, discover why ice is shaving, and then repair.
Dispensing crushed ice or reduced dispensing speed.	Water spillage from ice machine into dispenser bin.	Adjust ice machine.
	Agitation timer.	Test agitation timer.
	Bridge of ice sheet is too thick.	Adjust ice machine.
	Paddle wheel area broken or cracked.	Replace paddle wheel area.
	Ice clusters in bin.	Break up or remove clusters.
	Door not fully open.	Adjust door.
Door will not close.	Ice jammed in chute.	Adjust bridge in ice machine or, when manually filling, break up clusters.
	Door and/or door lock has come out of place.	Replace door and lock into proper position.
Mounting brackets for rocking chute have spread too far apart.		Bend parts into shape.

SELECTABLE ICE

Problem	Possible Cause	To Correct
DISPENSER DOES NOT DISPENSE CRUSHED ICE. Nothing is heard.	No power.	Check power source and power cord.
	Loose wire in electrical system.	Check wiring.
	Dispense switch faulty	Replace switch
	Crusher Motor Faulty.	Replace Motor/Gear Box.
	Dispenser Safety Switch Open.	Assure Merchandiser is installed correctly with the safety switch in the closed position.
Crusher motor hums but does not turn.	Blades obstructed.	Check for obstructions in ice crusher housing.
	Motor faulty	Replace Motor
	Faulty start relay/capacitor	Check relay/capacitor and replace if bad.
Crusher dispense door does not open.	Door solenoid faulty	Replace Solenoid
	Loose wiring to solenoid	Check wiring
Gear box on motor	Gear box on motor faulty.	Replace Ice Crusher Motor Assembly
	Crusher Axle broken	Replace Crusher Axle
Crusher Motor turns but Gear Motor for Paddle wheel/Agitator Bar does not turn.	Agitator Gear Motor faulty.	Replace Agitator Gear Motor.
	Loose wiring.	Check wiring
	Obstruction in Ice bin stopping motor	Check for obstruction
Nothing on dispenser works.	No power to dispenser	Check power source
	Dispenser Safety Switch opens	Assure Merchandiser is installed correctly with the safety switch in the closed position.
	Loose wiring	Check wiring.
Difficulty inserting Blade/Hub Assembly into Crusher housing	a. Stationary Blades not aligned with locating slots at top and bottom of crusher housing	See ""How to Disassemble for Maintenance"" section in this manual.
	b. Rotating Blades not in vertical position.	
	c. Check for ice in Crusher Housing.	
Crushed Ice dispenses continuously, or by itself.	Ice Dispense Switch Faulty	Adjust bridge in ice machine or, when manually filling, break up clusters.
No flashing lights on keypad, Fluorescent light was on, crusher and whole ice dispenser will not function, transformer breaker blown.	Water shorted out wiring harness on valves only.	Clean up water and reset transformer.

DRINKS

Condition	Investigation	Check	Correction
Water only dispensing	No pressure	Regulator(s) out of adjustment	Check/adjust regulator(s).
		Out of CO ₂	Install fresh tank.
		Defective regulator(s)	Check/repair/replace regulator(s).
		CO ₂ line pinched, kinked or obstructed	Check/repair/replace CO ₂ line.
Syrup and CO ₂ only dispensing	Carbonator	No power	Check power supply. Plug in carbonator or reset breaker.
		Water supply	Make sure water is turned "on".
			Replace water filter.
			Check/clean/replace pump strainer.
			Check/clean/repair water check valve.
Check for frozen water line. Internal carbonator unit only.			
Defective carbonator	Check/repair/replace carbonator pump, motor, electrode or liquid level control.		
Syrup and plain water only dispensing	No pressure	Out of CO ₂	Install fresh tank.
		HP regulator out of adjustment	Adjust HP regulator to the proper setting.
		Defective HP regulator	Check/repair/replace HP regulator.
		CO ₂ line pinched, kinked or obstructed	Check/repair/replace CO ₂ line.
One valve will not dispense anything	Is there power to the valve?	Broken wire or loose connection	Replace/repair wire or connector.
		Bad microswitch	Replace microswitch.
Beverage dispensed is too sweet	Is the ratio (brix) of the drink correct?	Flow control out of adjustment	Adjust the flow control.
		Insufficient soda flow due to low carbonator pressure	Adjust CO ₂ pressure or change the tank.
		Low CO ₂ pressure due to leaks	Repair CO ₂ leaks.
		Obstruction in the water or soda line	Clean out the lines.
Beverage is not sweet enough	Is the ratio (brix) of the drink correct?	Flow control out of adjustment	Adjust the flow control.
		Soda flow too high	Reset CO ₂ pressure or replace regulator if necessary.
		Obstruction in syrup line	Clean out the syrup line.
Drinks are foaming	Are system pressures correct?	Over carbonation	Check CO ₂ supply. Reset pressure or replace regulator if necessary.
		Dirty lines/valves	Clean/sanitize entire system.
No water, syrup or gas dispensing	Is there power to the unit?	No power	Plug in unit or reset breaker.
		Power to control box	Replace fuse or control box.
	Is power coming through the key switch?	Key switch "off"	Turn switch "on".
		Key switch defective	Replace key switch.
	Is there power to the key switch?	No power through the transformer	Reset/replace transformer.

FLAVOR SHOTS

Problem	Possible Cause	Corrective Action
Flavor shot syrup does not dispense when flavor button is depressed.	Syrup supply depleted.	Replace syrup.
	CO ₂ supply depleted.	Replace CO ₂ .
	BIB disconnect loose or packed with dried syrup residue.	Tighten and/ or clean BIB disconnect.
	CO ₂ Regulator set to low.	Check CO ₂ regulator for proper setting — 30 PSI (1 Bar) or according to line run.
	Kinked CO ₂ or syrup line.	Check lines for kinks.
	BIB pump inoperative.	Check pumps, replace if needed.
	Valve solenoid inoperative.	Check wiring to valve, replace solenoid.
	Vinyl tubing off at nozzle or at solenoid.	Reconnect tubing.
	Vinyl tubing plugged with syrup at nozzle or at solenoid.	Clean tubing and nozzle.
	Board not in dispense mode.	Place control board into dispense mode "0".
No power to control board.	Disconnected or loose wires.	Check connector to transformer and corresponding control board.
	No power to transformer.	Check power supply at transformer — 24 VAC.
Flavor syrup does not shut off.	Check for stuck solenoid	Replace solenoid if it continues to stick.

PUMP

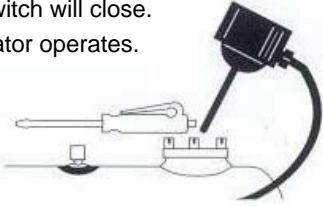
Problem	Possible Cause	Corrective Action
Pump motor does not shut off	Problem with probe or probe harness	<ol style="list-style-type: none"> 1. Remove probe electronics. 2. Pass magnetic tip of screwdriver by lower end of tube extending from electronics package. 3. Reed switch will close. 4. Carbonator operates. 
Pump motor intermittent		
Pump motor does not pump	Water pressure from water source is not high enough	Verify water pressure leading into pump inlet is 40 psi minimum.

THIS PAGE INTENTIONALLY LEFT BLANK

THIS PAGE INTENTIONALLY LEFT BLANK



© 2012 Maniowoc

Continuing product improvements
may necessitate change of
specifications without notice.

Part Number 020003997 4/12



Maniowoc Foodservice
2100 Future Drive
Sellersburg, IN 47172, USA
Ph: 812-246-7000 Fax: 812-246-7024
Visit us online at: www.manitowocfsg.com