



Servend Ice & Beverage Dispensing Units

Technician's Handbook

This manual is updated as new information and models are released. Visit our website for the latest manual.
www.manitowocfsg.com

Leader in Ice & Beverage Dispensers
Part Number STH14 9/10



Safety Notices

As you work on Manitowoc equipment, be sure to pay close attention to the safety notices in this handbook. Disregarding the notices may lead to serious injury and/or damage to the equipment.

Throughout this handbook, you will see the following types of safety notices:



Warning

Text in a Warning box alerts you to a potential personal injury situation. Be sure to read the Warning statement before proceeding, and work carefully.



Caution

Text in a Caution box alerts you to a situation in which you could damage the equipment. Be sure to read the Caution statement before proceeding, and work carefully.

Procedural Notices

As you work on Manitowoc equipment, be sure to read the procedural notices in this handbook. These notices supply helpful information which may assist you as you work.

Throughout this handbook, you will see the following types of procedural notices:

Important

Text in an Important box provides you with information that may help you perform a procedure more efficiently. Disregarding this information will not cause damage or injury, but it may slow you down as you work.

NOTE: Text set off as a Note provides you with simple, but useful, extra information about the procedure you are performing.

Read These Before Proceeding:

Caution

Proper installation, care and maintenance are essential for maximum performance and trouble-free operation of your Manitowoc equipment. If you encounter problems not covered by this handbook, do not proceed, contact Manitowoc Foodservice Group. We will be happy to provide assistance.

Important

Routine adjustments and maintenance procedures outlined in this handbook are not covered by the warranty.

Warning

PERSONAL INJURY POTENTIAL

Do not operate equipment that has been misused, abused, neglected, damaged, or altered/modified from that of original manufactured specifications.

We reserve the right to make product improvements at any time. Specifications and design are subject to change without notice.

Table of Contents

General Information

Model Numbers	9
How to Read a Model Number	9
Dispensing Basics	10
Accessories	13
Serial Number Location	15
Warranty Information	15

Installation

General	17
Dimensions	18
Pre-installation Checklist	31
Location	33
Drains	34
Water Supply	38
Setting Pressures	39

Component Identification

Typical Systems	43
System Components	46
Ice/Beverage and Counter Electric Dispensers	53

Maintenance

Cleaning	55
Disassembly	59
Replacement	79
Sanitizing	82
Shipping, Storage and Relocation	87

Operation

Blade Tower Brixing	89
CEV Electronic Ice & Carbonation Control	90
Flavor Magic Programming	93
Flav'R-Pic External Programming	97
Flav'R-Pic (FRP-250) Programming	100
Flav'R-Pic (FRP-250) Brixing Procedure	105
FlexTower Programming Modes	115
Adjustments	120

Agitation Timer	124
Troubleshooting	
Checklist	125
Liquid Level Control	137
Diagnosing a Defective Carbonator	138
Component Specifications	
Electrical Requirements	139
Minimum Circuit Ampacity	139
Grounding Instructions	141
Pump Deck Wiring	143
Water Supply	144
Charts	
Flavor Magic Logic Matrix	147
Flav'R-Pic (FRP-250) Logic Matrix	150
Diagrams	
Blade Tower Plumbing	153
CEV-30i & CEV-30e Plumbing	156
CEV-40i & CEV-40e Plumbing	158
CT-6 Plumbing and Wiring	160
CT-8 Plumbing and Wiring	161
CF-1522 Plumbing	162
DI-1522 Post-mix Plumbing	164
DI-1522 Pre-mix Plumbing	164
DI/DIL-2323 6 Valve Post-mix Plumbing	165
DI/DIL-2323 8 Valve Post-mix Plumbing & Variety Valve	166
DI/DIL-2323 10 Valve Post-mix Plumbing	167
DI/DIL-2323 6 Valve Pre-mix Plumbing .	168
Flavor Magic Plumbing	169
FRP-250 Plumbing Diagram	170
FRP-250 & FRP-250SCI Tubing Layout .	171
FT-8 Plumbing	172
FT-12 Plumbing	172
FlexTower Water Recirculation Pump Flow	173
FlexTower Water Chiller Flow	173
MDH-302 12 Valve Plumbing	174
MDH-402 16 Valve Plumbing	175

MDH-402 20 Valve Plumbing	176
S/SV150 6 Valve Diagram	177
S/SV175 8 Valve Diagram	177
S/SV200/250/SV-250QD 8 Valve Diagram	178
S/SV200/250 10 Valve Diagram	178
Flex Manifold Diagrams	180
CEV Wiring	181
CF Drop-In Series Wiring	187
Drop-in Wiring	188
Flavor Magic Wiring	192
Flav'R-Pic (FRP-250) Wiring	193
FlexTower Wiring	195
MDH-302 & MDH-402 Wiring	199
NGF-250 Wiring	201
quickdraw Wiring	202
S/SV/SVi Wiring	203
Selectable Ice Wiring	205

This Page Intentionally Left Blank

General Information

Model Numbers

This manual covers the following models:

CEV-30j	CEV-30e	CEV-30i
CEV-40e	CEV-40i	CT-6
CT-8	DI-1522	DI-2323
DIL-2323	FRP-250	FRP-250SCI
FT-8	FT-12	FT-16
M-15	M-45	M-90
MDH-302	MDH-402	MDH-302CI
MDH-302SCI	MDH-402CI	MDH-402SCI
NGF-250	NGF-250QD	S-150
S-200	S-250	SV-150
SV-175	SV-200	SV-250
SV-150i	SV-175i	SV-200i
SV-250i	SV-250QD	SV-200SCI
SV-250SCI	BLADE TOWER	FLAVOR MAGIC

How to Read a Model Number

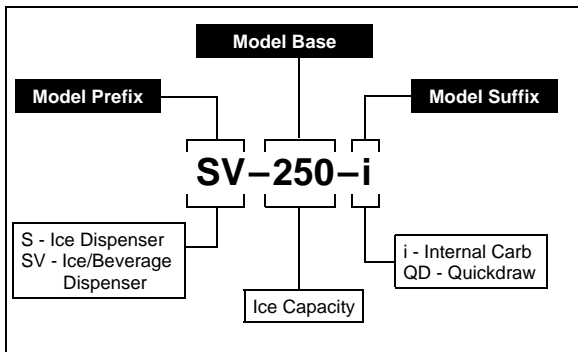

Manitowoc Foodservice developed this manual as a reference guide for the service agent and installer of fountain equipment.

Fountain dispensing is the serving of a beverage (soft drink, tea, or juice, etc.) from a dispenser that will chill the product to an acceptable serving temperature for the consumer.

The beverage, delivery system and dispenser can be postmix or premix. The system may be an elaborate system with most of the components in the back of the store and the dispenser in the front. Fountain systems could be a simple system with the complete system under the counter where the dispenser is located.

Our goal is that this manual will remove some of the confusion, and mystery of beverage dispensing equipment while providing a general overview of service to the equipment.

Dispensing Basics

WHAT IS CARBONATION

Carbonation is the process of mixing carbon dioxide gas into a liquid (water). The resulting liquid is called soda water or carbonated water. The carbon dioxide gas is the bubbles you see when a carbonated beverage (like soda) is dispensed.

Most cola, lemon-lime products, etc. are carbonated. Normally teas, juices, etc. are noncarbonated.

Some beverage technicians refer to noncarbonated water as sweet water.

WATER CHARACTERISTICS

Water makes up over 80% of the typical finished beverage. The quality of this primary ingredient is of utmost importance. You should use regular cold tap water, not water that has been through a water softener, conditioner, etc. Any off taste or color should be treated by proper water filtration.

WATER FILTERS

It is recommended that proper water filters treat the water supply for the beverages. There are two basic filters commonly in use.

1. Pre-filter, or sand filter. This filter removes any foreign matter from the water down to 25 microns in size.
2. Carbon or activated charcoal filter is also used. This filter will reduce chlorine and other chemicals, off-taste and odor. Some of the higher quality filters may reduce organic compounds (bacteria) in the water.

Do not use a filter containing any type of phosphate on the beverage system. Phosphate as used for scale reduction will cause the beverage to lose its carbonation and become “flat” quickly.

WATER PRESSURES

Dynamic (flowing) water pressures to most carbonators should be a minimum of 40 PSI (1.38 bar). Water pressure to dispensers for noncarbonated beverages should be a minimum of 50 pounds (22.7 kg). These pressures are minimum operating pressures, not static pressure.

SYRUP BASICS

Your concentrated syrup containers should be stored in a cool dry location that is easily accessible. Any extremes in temperature can wreak havoc with the quality of the product. For best results, the syrup should be maintained in an environment between 40° and 90°F (4.4° and 32.2°C).

PREMIX

Premix fountain dispensing consists of a container of beverage ready for dispensing, beverage delivery system, carbon dioxide (CO₂) propellant, beverage cooling system, and dispenser. We shall discuss each component of this type of system within the context of this manual.

The major advantage of a premix system over most other types is its flexibility. This flexibility is the ability to go anywhere. Many premix systems will operate without electric power or separate water supply.

POSTMIX

Postmix fountain dispensing consists of either a tank (called a Figo) or a box (called a Bag-in-Box) of beverage syrup. The postmix system will also include the carbonator, fresh water supply, carbon dioxide (CO₂) supply, syrup delivery system, beverage cooling system, and dispenser. We shall discuss each component of this type of system within the context of this manual.

The major advantage of the postmix system over most other systems is the very low cost of delivering a high quality, fresh beverage to the consumer utilizing less floor and storage space for the quantity of beverages served.

PIPING

The fountain system is connected together by a series of tubing or hoses. This tubing is called beverage tube and is commonly available in 1/4" (0.64 cm), 3/8" (0.95 cm), and 1/2" (1.27 cm) inside diameters. Beverage tubing is a flexible, high-pressure tubing. This tubing is capable of withstanding system pressures in excess of 100 PSI (6.9 bar). The beverage tubing may be an individual line or assembled with many lines of tubing bundled together.

The beverage tubing is attached to the various components of the system with barbed stems, nuts, tees, etc. The tubing is held onto the fittings with small tube clamps called stepless (Oetiker®) clamps. When attaching the tubing and fitting to a "flared" fitting, the use of a flare washer is required.

Several different types of tubing are available for the beverage industry. If there is any possibility of the tubing laying in a damp environment, the use of non-permeable tubing should be used. Tubing is also available as a single tube or bundled together. Single tube is available as non-permeable plastic or stainless steel. Bundled tube is available as plastic only.

Accessories

BAFFLE FOR MANITOWOC® ICE MACHINES

When installing a Manitowoc Ice Machine on a dispenser, a baffle kit is required for proper installation. The baffle kit is designed to prevent ice from lying against the front of the ice machine, and melting down the front of the dispenser. There are two different baffle kits available for "S" series ice machines, one kit is for the 30" (76.2 cm) wide machine, and the other kit is for the 22" (55.9 cm) wide machine. There is also a kit for "Q" series ice machines.

Kits are available through your local distributor. List prices may be subject to change without notification. Please call your local parts distributor for current pricing before ordering.

NOTE: For full information about ice machine installation, including plumbing lines connections and electrical requirements, see the ice machine installation manual.

MANUAL FILL LID FOR DISPENSERS WITH AN ICE MACHINE

If you are top mounting your dispenser with an ice machine, you will require a lid for the manual fill area at the top, front of the dispenser.

If you ordered a dispenser and an ice machine at the same time, the manual fill lid may be included with the unit. The manual fill lid can be ordered from your local distributor.

LEGS

Legs are optional equipment with most MBE dispensers. Standard legs are 4" (10.2 cm) tall stainless steel legs. We do not recommend using legs

when an ice machine is mounted on the dispenser. The combined weight of the dispenser, ice and ice machine is more evenly distributed when the base area of the dispenser is in contact with the countertop.

Serial Number Location

This number is required when requesting information from your local distributor. The serial number is listed on the SERIAL NUMBER DECAL affixed to the dispenser.

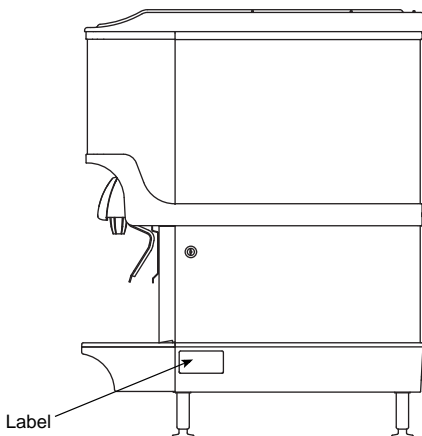

Serial Number Location

Warranty Information

Consult your local MBE Distributor for terms and conditions of your warranty. Your warranty specifically excludes all beverage valve brixing, general adjustments, cleaning, accessories and related servicing.

Your warranty card must be returned to MBE to activate the warranty on this equipment. If a warranty card is not returned, the warranty period can begin when the equipment leaves the MBE factory.

No equipment may be returned to MBE without a written Return Materials Authorization (RMA). Equipment returned without an RMA will be refused at MBE's dock and returned to the sender at the sender's expense.

Please contact your local MBE distributor for return procedures.

This Page Intentionally Left Blank

Installation

General

These instructions are provided to assist the qualified installer. Contact your Manitowoc Beverage Equipment Service Agent or call Manitowoc Beverage Equipment for information regarding start-up services.

Important

Failure to follow these installation guidelines may affect warranty coverage.

Dimensions

ICE/BEVERAGE & COUNTER ELECTRIC DISPENSER DIMENSIONS

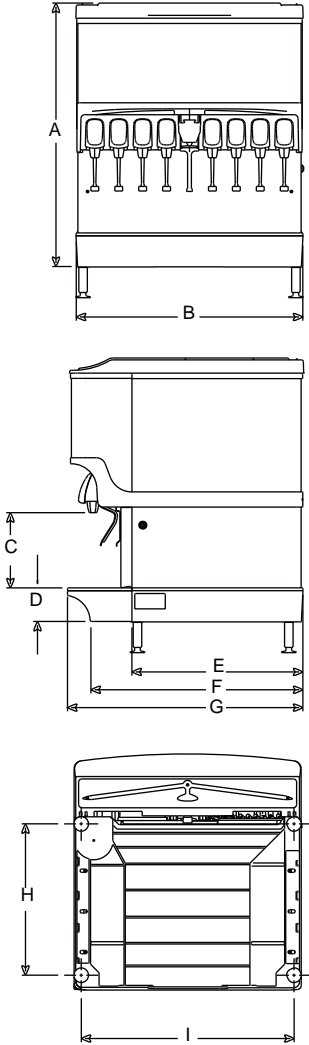

Note: Graphic above is for illustration purposes only, and may not look like your unit.

MODEL	A	B	C*	D	E	F	G	H	I
CEV-30	29.88" (75.9 cm)	20.50" (52.7 cm)	11.76" (29.8 cm)	4.44" (11.3 cm)	N/A	N/A	25.75" (65.4 cm)	17.00" (43.1 cm)	17.50" (44.4 cm)
CEV-40	29.88" (75.9 cm)	26.00" (66.0 cm)	11.76" (29.8 cm)	4.44" (11.3 cm)	N/A	N/A	25.75" (65.4 cm)	17.00" (43.1 cm)	23.00" (58.4 cm)
M-45	24.25" (61.6 cm)	15.00" (38.10 cm)	9.75" (24.8 cm)	4.44" (11.3 cm)	17.88" (45.4 cm)	26.37" (67.0 cm)	28.00" (71.1 cm)	19.37" (49.2cm)	12.75" (32.4 cm)
M-90	32.00" (81.30 cm)	15.00" (38.10 cm)	9.75" (24.8 cm)	4.44" (11.3 cm)	18.00" (45.7 cm)	26.37" (67.0 cm)	28.00" (71.1 cm)	19.37" (49.2cm)	12.75" (32.4 cm)
MDH-302 (SCI)	33.00" / 44.00" w/EMerch (83.8 cm / 111.7 cm)	42.75" (108.5 cm)	9.94" (17.6 cm)	4.44" (11.3 cm)	22.50" (57.2 cm)	28.00" (71.1 cm)	30.50" (77.4 cm)	20.50" (52.0 cm)	38.75" (98.4 cm)
MDH-402 (SCI)	32.00" / 44.00" w/EMerch1 / 54.00" w/EMerch2 (81.2 cm / 111.7 cm 137.1 cm)	60.00" (152.4 cm)	9.94" (17.6 cm)	4.44" (11.3 cm)	22.50" (57.2 cm)	28.00" (71.1 cm)	30.50" (77.4 cm)	21.25" (54.0 cm)	56.50" (143.6 cm)
S/SV-150	24.81" (63.0 cm)	23.00" (58.4 cm)	9.94" (17.6 cm)	4.44" (11.3 cm)	22.63" (57.5 cm)	28.00" (71.1 cm)	31.13" (79.1 cm)	20.00" (50.8 cm)	20.44" (51.9 cm)
S/SV-175	24.81" (63.0 cm)	23.00" (58.4 cm)	9.94" (17.6 cm)	4.44" (11.3 cm)	22.63" (57.5 cm)	28.00" (71.1 cm)	31.13" (79.1 cm)	20.00" (50.8 cm)	22.44" (57.0 cm)
S/SV-200	34.81" (88.4 cm)	30.00" (76.2 cm)	9.94" (17.6 cm)	4.44" (11.3 cm)	22.63" (57.5 cm)	28.00" (71.1 cm)	31.13" (79.1 cm)	20.00" (50.8 cm)	27.44" (69.7 cm)
S/SV/FRP/ NGF-250 (QD & SCI)	39.81" (101.1 cm)	30.00" (76.2 cm)	9.94" (17.6 cm)	4.44" (11.3 cm)	22.63" (57.5 cm)	28.00" (71.1 cm)	31.13" (79.1 cm)	20.00" (50.8 cm)	27.44" (69.7 cm)

* C = Valve height using Flomatic Valves.

DROP-IN & CT DIMENSIONS

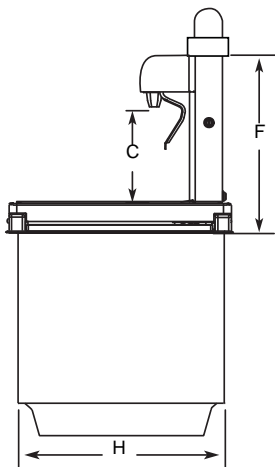
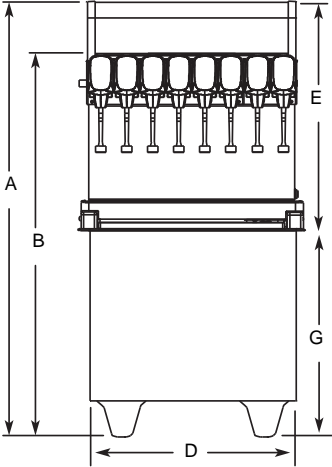

MODEL	A	B	C*	D	E	F	G	H
CT-6	N/A	N/A	9.50" (24.2 cm)	14.25" (36.2 cm)	17.00" (43.2 cm)	16.38" (42.8 cm)	N/A	22.50" (57.2 cm)
CT-8	N/A	N/A	9.50" (24.2 cm)	15.50" (39.8 cm)	25.00" (63.5 cm)	23.75" (60.4 cm)	N/A	22.85" (58.1 cm)
DI-1522	44.38" (112.8 cm)	38.38" (97.5 cm)	9.50" (24.2 cm)	15.00" (38.2 cm)	22.38" (56.9 cm)	16.38" (42.8 cm)	22.00" (55.9 cm)	22.00" (55.9 cm)
DI/DIL-2323	56.75" (144.2 cm)	46.75" (118.8 cm)	9.50" (24.2 cm)	23.00" (58.5 cm)	33.75" (85.8 cm)	23.75" (60.4 cm)	23.00" (58.5 cm)	23.00" (58.5 cm)

FLEXTOWER DIMENSIONS

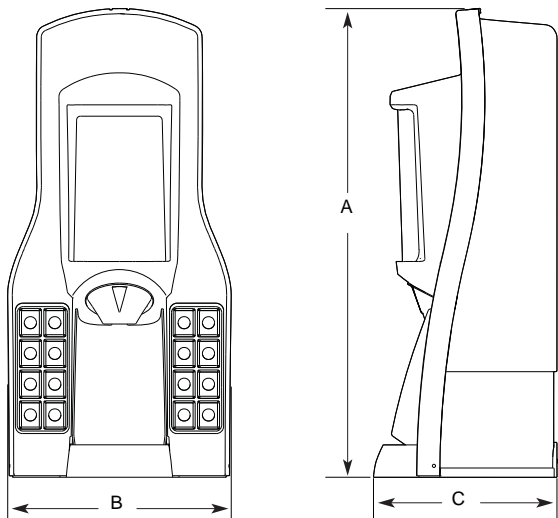

MODEL	A	B	C
FT-8/12/16	36.00" (91.5 cm)	14.00" (35.6 cm)	9.50" (24.2 cm)

BLADE TOWER DIMENSIONS

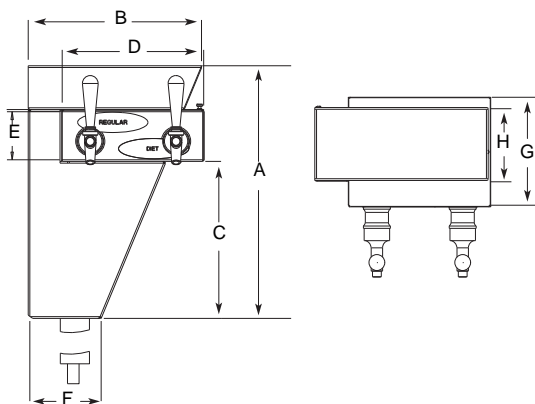

MODEL	A	B	C	D
BLADE TOWER	17.30" (44.0 cm)	11.86" (30.2 cm)	10.75" (27.3 cm)	9.68" (24.6 cm)
	E	F	G	H
	3.29" (8.4 cm)	4.88" (12.4 cm)	7.39" (18.8 cm)	5.00" (12.7 cm)

ICE/BEVERAGE & COUNTER ELECTRIC DISPENSER FOOTPRINTS

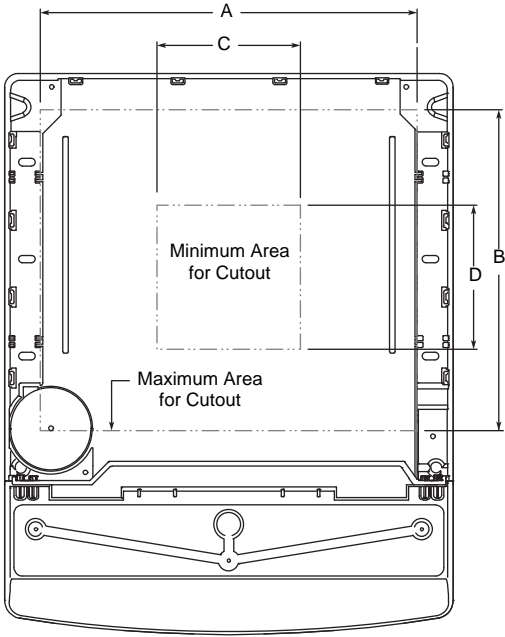

NOTE: Footprint above is for illustration purposes only, and may not look like the bottom of your unit.

MODEL	Maximum		Minimum	
	A	B	C	D
CEV-30	14.50" (36.8 cm)	12.50" (31.7 cm)	8.00" (20.3 cm)	8.00" (20.3 cm)
CEV-40	20.00" (50.8 cm)	12.50" (31.7 cm)	8.00" (20.3 cm)	8.00" (20.3 cm)
M-45	8.00" (20.3 cm)	12.00" (30.5 cm)	8.00" (20.3 cm)	12.00" (30.5 cm)
M-90	8.00" (20.3 cm)	12.00" (30.5 cm)	8.00" (20.3 cm)	12.00" (30.5 cm)
MDH-302*	36.75" (93.3 cm)	20.50" (52.1 cm)	8.00" (20.3 cm)	12.00" (30.5 cm)
MDH-402*	38.75" (98.4 cm)	20.50" (52.1 cm)	8.00" (20.3 cm)	12.00" (30.5 cm)
S/SV-150	19.00" (48.3 cm)	17.81" (45.2 cm)	8.00" (20.3 cm)	8.00" (20.3 cm)
S/SV-175	21.00" (53.3 cm)	17.81" (45.2 cm)	8.00" (20.3 cm)	8.00" (20.3 cm)
S/SV-200 & 250**	26.00" (66.0 cm)	17.81" (45.2 cm)	8.00" (20.3 cm)	8.00" (20.3 cm)

* Includes models ending in SCI

** Includes NGF, FRP, and models ending in QD or SCI



Warning

Cutting the countertop may decrease its strength. Counter must be braced to support the dispenser countertop weight plus ice storage capacity and weight of ice machine, if applicable.

DROP-IN & CT FOOTPRINTS

DI/DIL-1522 & 2323

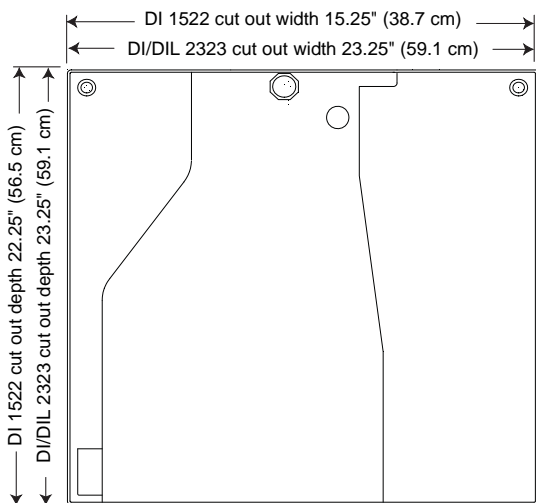

CT-6

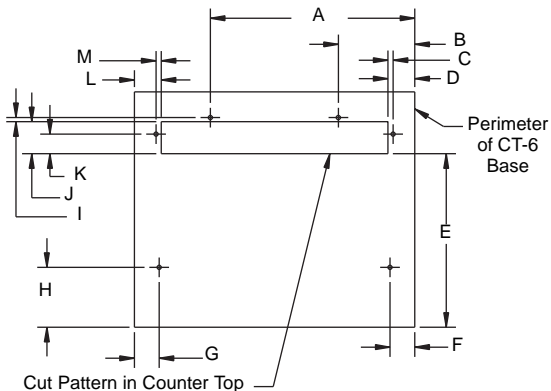

A	B	C	D	E
12.375" (31.43 cm)	4.625" (11.75 cm)	0.313" (0.80 cm)	1.625" (4.13 cm)	10.50" (26.67 cm)
F	G	H	I	J
1.50" (3.81 cm)	1.50" (3.81 cm)	3.625" (9.21 cm)	0.25" (0.64 cm)	1.938" (4.92 cm)
K	L	M		
1.188" (3.02 cm)	1.625" (4.13 cm)	0.313" (0.80 cm)		

CT-8

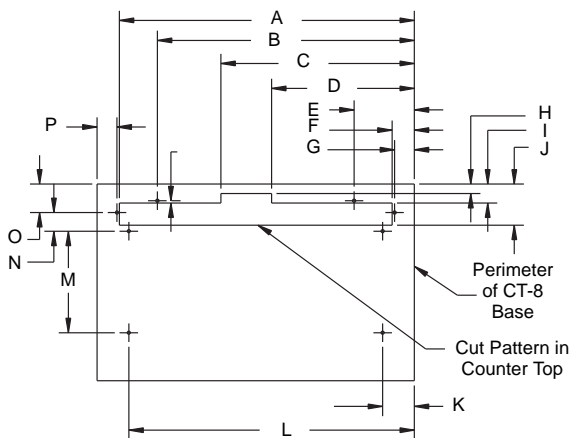

A	B	C	D
23.25" (59.1 cm)	20.25" (51.44 cm)	15.25" (38.74 cm)	11.25" (28.58 cm)
E	F	G	H
4.75" (12.07 cm)	1.75" (4.45 cm)	1.56" (3.96 cm)	0.75" (1.91 cm)
I	J	K	L
1.50" (3.81 cm)	3.25" (8.26 cm)	2.50" (6.35 cm)	22.50" (57.15 cm)
M	N	O	P
8.00" (20.32 cm)	1.47" (3.73 cm)	2.25" (5.72 cm)	1.56" (3.96 cm)

FLEXTOWER FOOTPRINT

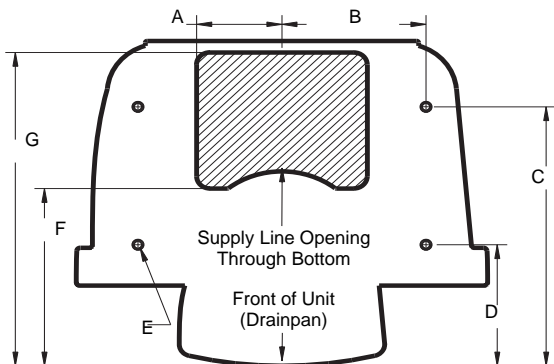

A	B	C	D
(2X) 3.407" (8.65 cm)	(2X) 5.75" (14.61 cm)	(2X) 11.265" (28.61 cm)	(2X) 5.265" (13.37 cm)
E	F	G	
(4X) Ø 0.25" (0.64 cm)	7.701" (19.56 cm)	13.627" (34.61 cm)	

NOTE: The FlexTower must be secured to the countertop using the four holes provided in the base of the unit and using the hardware provided. Follow customer guidelines for placement of the unit or approximately 10 inches (25.4 cm) from the edge of the counter. A mounting template is provided which is printed on the shipping carton. **NOTE: DO NOT DISCARD SHIPPING CARTON UNTIL MOUNTING TEMPLATE IS REMOVED.**

BLADE TOWER FOOTPRINT

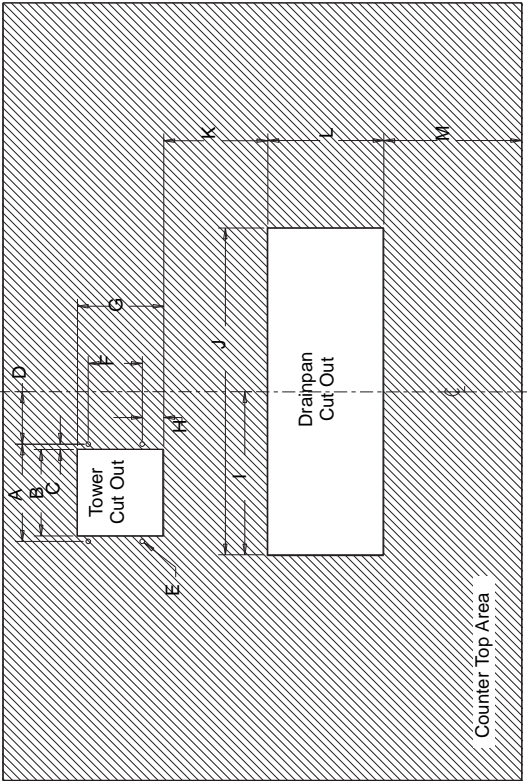

A	B	C	D	E
4.50" (11.43 cm)	4.00" (10.16 cm)	0.25" (0.64 cm)	2.43" (6.17 cm)	Ø 0.218" (0.55 cm) (4 places)
F	G	H	I	J
2.50" (6.35 cm)	4.00" (10.16 cm)	1.00" (2.54 cm)	7.55" (19.18 cm)	15.13" (38.43 cm)
K	L	M		
4.82" (12.24 cm)	5.38" (13.67 cm)	6.38" (16.21 cm)		

Pre-installation Checklist

TOP MOUNTED ICE MACHINE INSTALLATIONS

- Location** — Avoid placing the dispenser and/or ice machine near heat sources such as radiators, ovens, and direct sunlight.

- Clearances** — Six inch (15.2 cm) clearance on all sides of the icemaker is needed.

- Front of icemaker to be flush with front of dispenser** — The front of the icemaker must be flush with the front of the dispenser. When the icemaker is flush with the front of the dispenser, some icemakers may overhang at the back of the dispenser.

- Drains** — A separate drain line is required for the ice machine, in addition to a drain line for the ice/beverage dispenser.

- Dispensers may require an adapter kit to install some top-mounted icemakers. Contact your local distributor for the correct adapter kit.

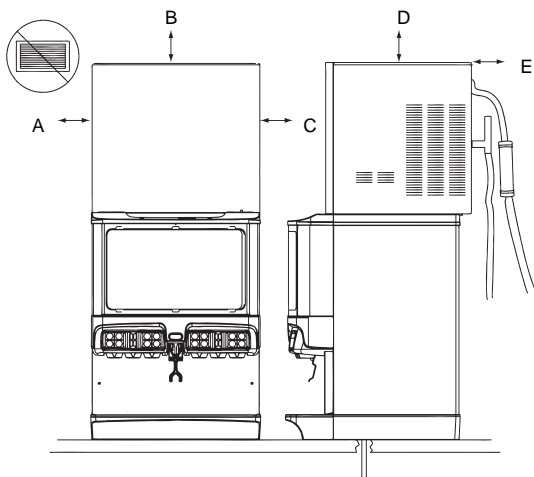

A	B	C	D	E
6" (15.2 cm)	6" (15.2 cm)	6" (15.2 cm)	6" (15.2 cm)	6" (15.2 cm)

For full information about icemaker installation, including plumbing lines connections and electrical requirements, see the icemaker installation manual.

Location

The location selected for the beverage dispenser must meet the following criteria. If any of these criteria are not met, select another location.

- The air temperature must be at least 50°F (10°C), but must not exceed 95°F (35°C).
- The location must not be near heat-generating equipment or in direct sunlight and must be protected from weather.
- The countertop must be level. Verify that the countertop can support the weight of the dispenser, or the dispenser/ice machine combination plus the weight of the stored ice.
- Water lines, drains and power outlet must be within 6' (1.8 m) of location.



Warning

Carbon Dioxide (CO₂) displaces oxygen. Exposure to a high concentration of CO₂ gas causes tremors, which are followed rapidly by loss of consciousness and suffocation. If a CO₂ gas leak is suspected, particularly in a small area, immediately ventilate the area before repairing the leak. CO₂ lines and pumps must not be installed in an enclosed space. An enclosed space can be a cooler or small room or closet. This may include convenience stores with glass door self serve coolers. If you suspect CO₂ may build up in an area, venting of the B-I-B pumps and/or CO₂ monitors must be utilized.

Drains

ICE & ICE/BEVERAGE DISPENSER DRAINS

Drainage Through Bottom

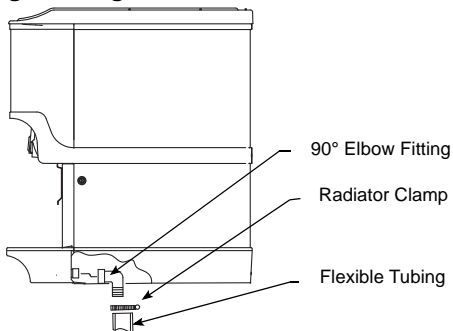

Drainage Through Back

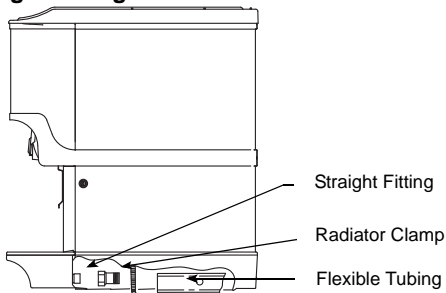

Rear View

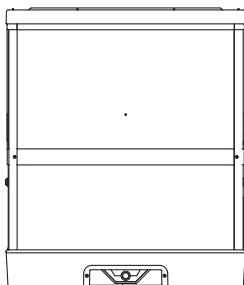

Rear Access for Drain Hose
and Beverage Lines

FLEXTOWER DRAIN

Drainage Through Bottom

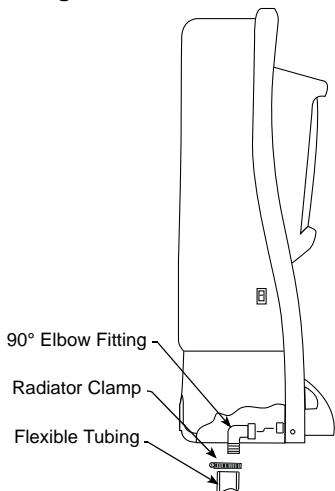

Drainage Through Back

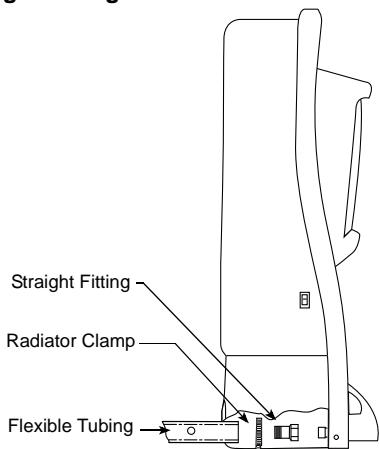

Rear View

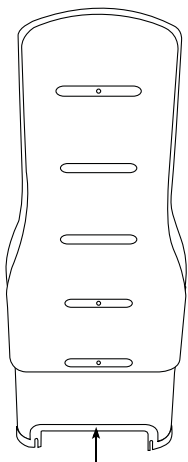

Rear Access for Drain Hose
and Beverage Lines

BLADE TOWER DRAIN

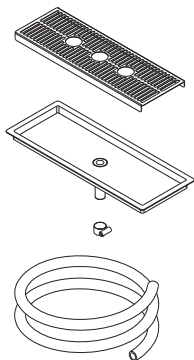

Flush Mount Drain — 020001388

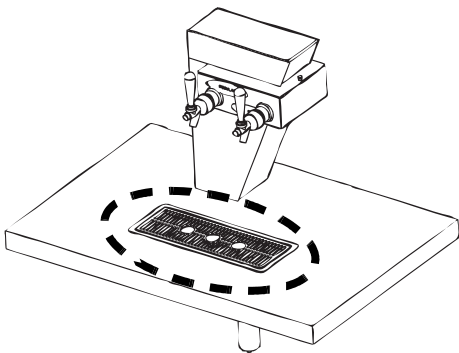

NOTE: The Blade Tower can be set up to use an existing drain or an optional drain can be ordered for use with the tower. The illustration above shows the optional flush mount drain setup (Part Number 020001388). If using the optional flush mount drain, be sure to plumb according to local codes.

Water Supply

RECOMMENDED PLUMBING

The plumbing diagram is printed on a white vinyl label, located above the inlet tubes for syrup and water. The plumbing diagram label can be accessed by removing the splash panel of the dispenser. The plumbing diagram label explains which inlet coldplate fittings supply which dispenser valves and water manifolds.

The water supply must first be connected to the carbonator pump (not shown) before plumbing to connection "A" shown on the plumbing diagram. The carbonator pump deck must be within six feet (1.8 m) of the dispenser for optimum performance. See the B-I-B installation diagram for system pressure settings.

Important

When installing cold carbonated (Internal Carb) equipment, never put a tee for the plain water connection in the line from the pump deck to the cold plate. Putting a tee in the line will create service problems and bad drink quality.

NOTE: Valves are read from right to left.

A check valve must be installed in the water supply line 3 feet (0.9 m) from the noncarbonated water connection "PW". Contact factory if not installed.

Important

When installing a CEV unit the lowest recommended TDS reading for the water bath is 100 PPM.

Setting Pressures

PRE-MIX PRESSURES

Normal pre-mix pressure regulators must be set at 60 psi (4.14 bar). Diet pre-mix pressure regulators must be set at 40 psi (2.76 bar). If you are experiencing high foaming, decreasing the pressures may correct the problem. Spitting and popping usually requires slightly increasing the pressures. Pre-mix beverage valve pressures vary by type and manufacturer. Please consult the manufacturer of the valves you are using for specific instructions regarding operation of the valve.

COLD CARB AND AMBIENT SYSTEM PRESSURES

1. **Incoming tap water** — must be at a minimum dynamic pressure of 40 psi (2.76 bar) and maximum static pressure of 65 psi (4.48 bar) (measured at inlet to pump).

Important

If incoming water pressure is under 40 psi (2.76 bar), a water booster is recommended. If incoming water pressure is over 65 psi (4.48 bar), a water regulating valve is required.

2. B-I-B pressure gauge must be set for a minimum of 60 psi (4.14 bar) or according to your line run.
3. Carbonator Pressure gauge (Use Preset Regulator):
 - Cold Carbonation set for 75 psi (5.17 bar).
 - Ambient systems must be set at 90 psi to 105 psi (6.20 bar to 7.24 bar).

QUICKDRAW INSTALLATION

Warning

Personal Injury
Hazardous Moving Parts

Do not adjust regulator valve above 50 psig (3.45 bar).

Recommended operating parameters are 40 - 50 psig (2.76 - 3.45 bar).

NOTE: The Quickdraw unit requires a supply of CO₂. The pressure requirement for the CO₂ supply is 75 psig (5.17 bar). The adjustable Ice Dispense CO₂ regulator in the electric box must be set at 40 to 45 psi (2.76 to 3.10 bar). The Ice Dispense CO₂ Regulator must never be set above 45 psi (3.10 bar).

Turn CO₂ supply on to the dispenser. Each cold carb pump deck is furnished with a fixed regulator set at 75 psi (5.17 bar). Ambient units need to be set between 90 and 105 psi (6.24 and 6.90 bar).

Important

The ice portion sizes must be adjusted to customer requirements at the time of installation. (See the Quickdraw Ice Portion Adjustments section for more information.)

BACK ROOM PACKAGE

Incoming tap water — Must be at a minimum dynamic pressure of 40 psi (2.76 bar) and maximum static pressure of 65 psi (4.48 bar). If pressure can not be attained, a water booster may be needed.

Carbonator Water pump motor — Powers the water pump. The water pump motor is part of the carbonator pump deck.

Carbonator Water pump — Pumps tap water into the carbonator tank. The water pump is part of the carbonator. The incoming water for the carbonator must be first run through the pump before connecting to the proper cold plate inlet.

Internal/External Carbonator tank — Combines CO₂ gas and tap water to form carbonated water. The “carbonator” is the carbonator tank, water pump and water pump motor.

CO₂ cylinder — Holds highly pressurized carbon dioxide (CO₂). The CO₂ cylinder is a steel or aluminum cylinder tank. CO₂ gas flows through the primary pressure regulator.

Bag-In-Box (B-I-B) pressure gauge — Set for 60 - 80 psi (4.14 - 5.51 bar). Indicates CO₂ pressure going to B-I-B pumps.

Primary pressure regulator — Lowers the CO₂ gas pressure, to 100 psi (6.90 bar), so the CO₂ gas will be at the proper pressure to enter the carbonator regulator.

Lowered outgoing pressure — Set for 75 psi (5.17 bar). Gauge indicates lowered outgoing pressure from the CO₂ cylinder after being routed through the primary pressure regulator at 90 psi to 105 psi (6.20 bar to 7.24 bar).

Secondary pressure regulator — Lowers the CO₂ gas pressure before the CO₂ gas flows to the syrup pump. CO₂ pressure activates the syrup pump. 30 psi (2.07 bar) on Flavor Magic and FRP-250 units with flavor shots.

Syrup pump — Draws syrup out of the bag-in-box syrup package. Syrup flows through the syrup lines to the dispenser for chilling, then dispensing. There is a syrup pump for each bag-in-box syrup system.

Bag-In-Box (B-I-B) syrup cartons — Box which contains a plastic bag, filled with syrup.

This Page Intentionally Left Blank

Component Identification

Typical Systems

TYPICAL INTERNAL CARBONATION (IC) ICE/BEVERAGE DISPENSING SYSTEM

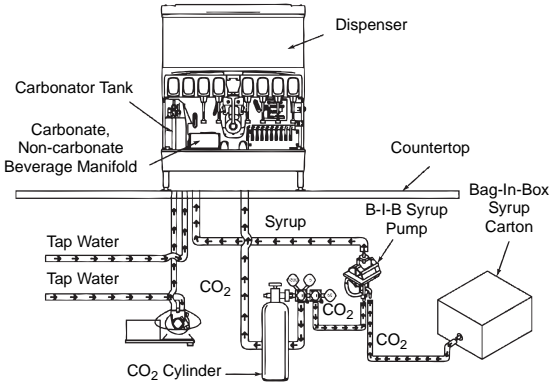

TYPICAL EXTERNAL CARBONATION (AMBIENT) ICE/BEVERAGE DISPENSING SYSTEM

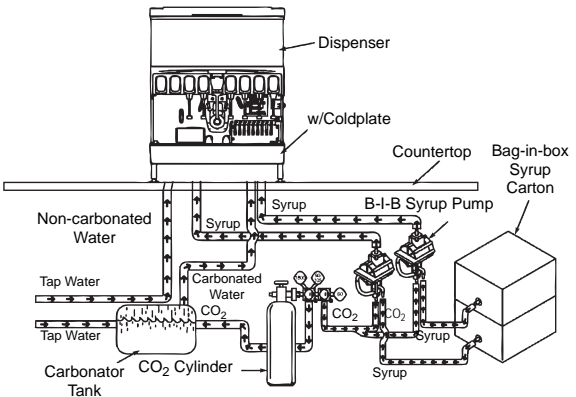

TYPICAL INTERNAL CARBONATION (IC) CEV DISPENSING SYSTEM

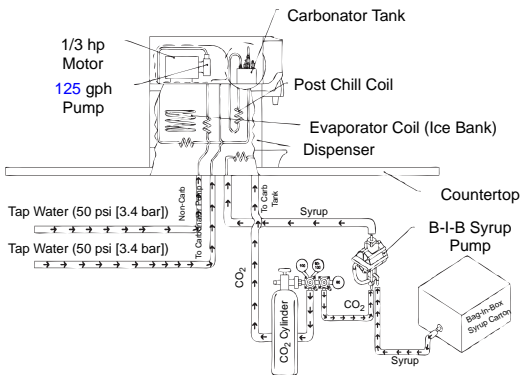

NOTE: This is a simplified schematic to show the basic operation of the beverage system.

TYPICAL EXTERNAL CARBONATION (AMBIENT) CEV DISPENSING SYSTEM

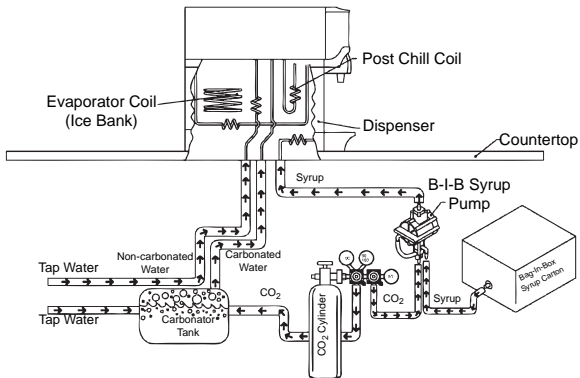

NOTE: This is a simplified schematic to show the basic operation of the beverage system.

CEV ELECTRONIC ICE & CARBONATION CONTROL

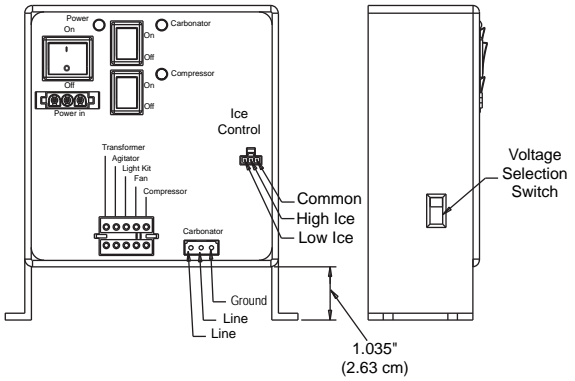

System Components

BLADE TOWER

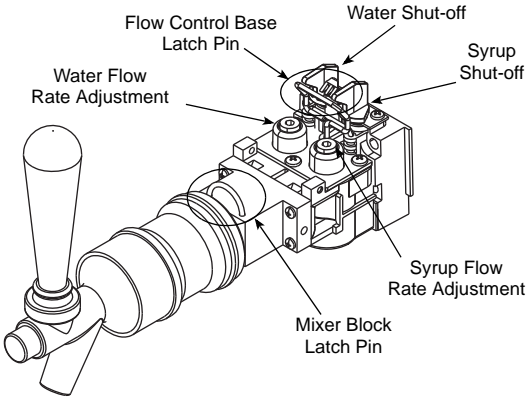
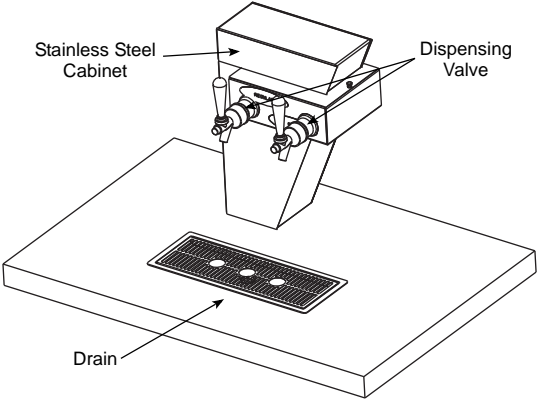

DROP-IN

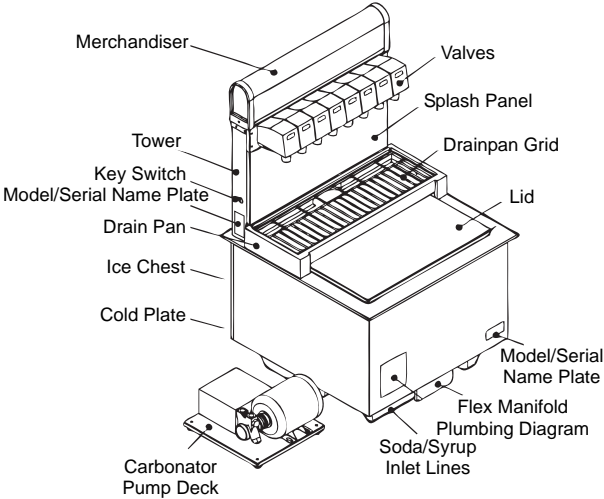

FLAVOR MAGIC MODULE

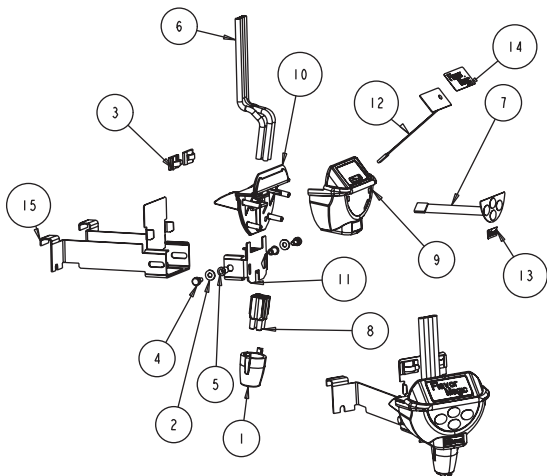

Item Number	Part Number	Description
1	501-25	NOZZLE SOFTPOUR BLK
2	00850350	FLAT WASHER 0.218ID X
3	0905403	CLIP PLAS WIRE & CORD
4	5012790	SCR 10-32X3/8 KNURL UNSLT
5	5029806	RIVNUT 10-32 .020-.130
6	5030446	TUBING 1/4IN OD X 4FT
7	5031193	KEYPAD 4 BUTTON 5 PIN FM
8	5031453	RETAINER QUAD TUBE FM
9	020000473	CVR FRONT FM ICEPIC
10	020000493	CVR REAR FM ICEPIC
11	020000846	BRKT MNTG CENTER
12	020001033	PAD LED FM
13	020001034	LABEL LOGO SERVEND HORZ
14	020001035	LABEL FM GRAPHIC
15	20001153	BRKT WELDED FM

FLEXTOWER

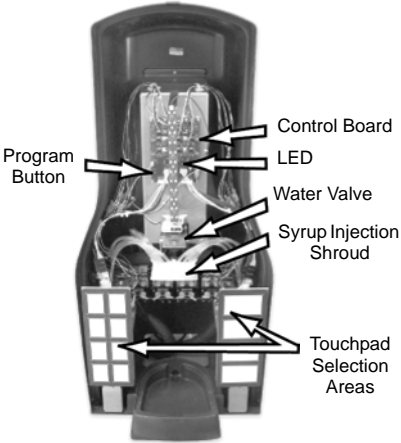
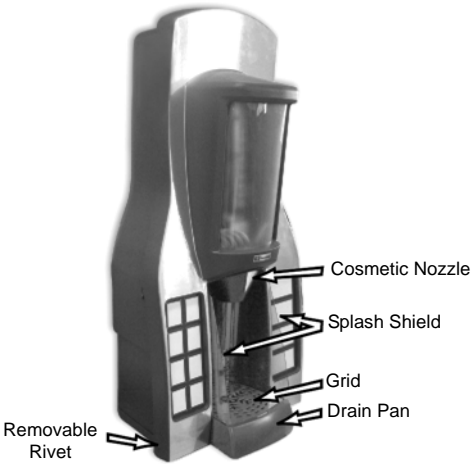

FLAV'R-PIC (FRP-250 & FRP-250SCI)

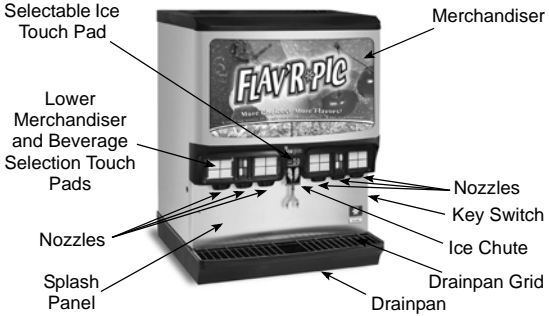

INTERNAL CARBONATORS

Vertical Carbonator

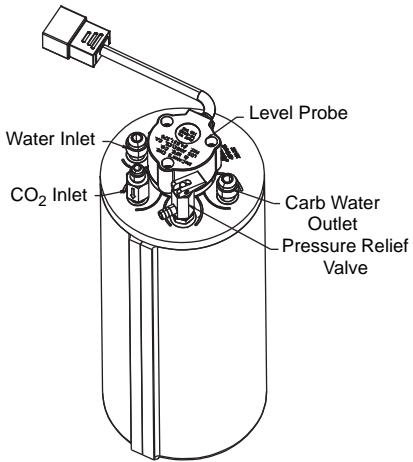

Horizontal Carbonator

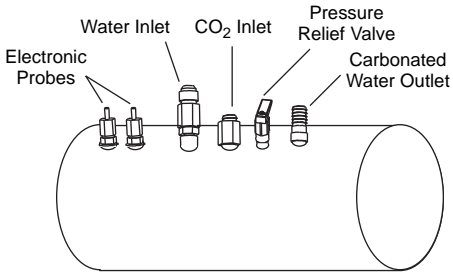

BAG-IN-BOX (B-I-B) SYSTEM

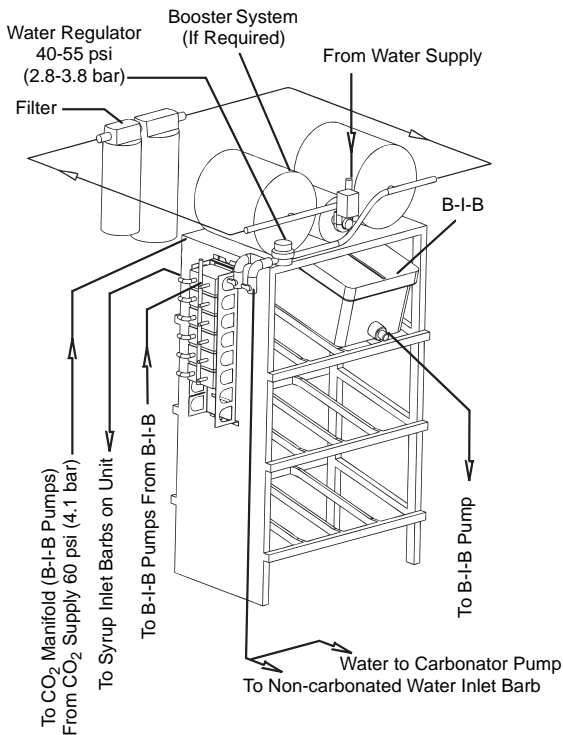

Ice/Beverage and Counter Electric Dispensers

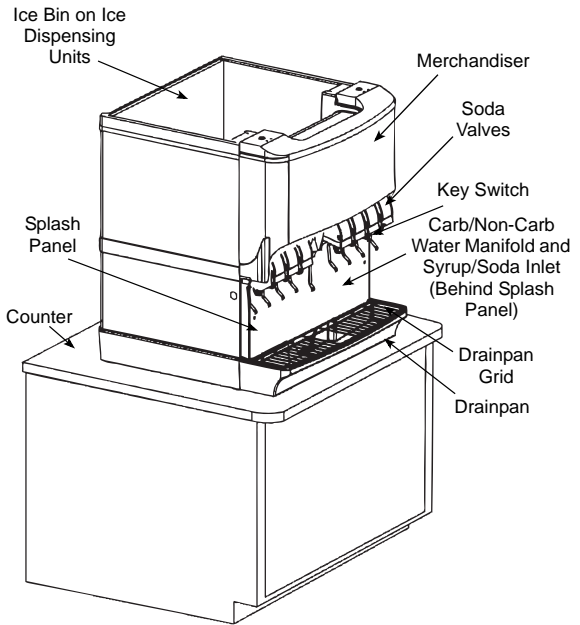

MDH-402 (CI & SCI) INTERNAL CARBONATION DISPENSING SYSTEM

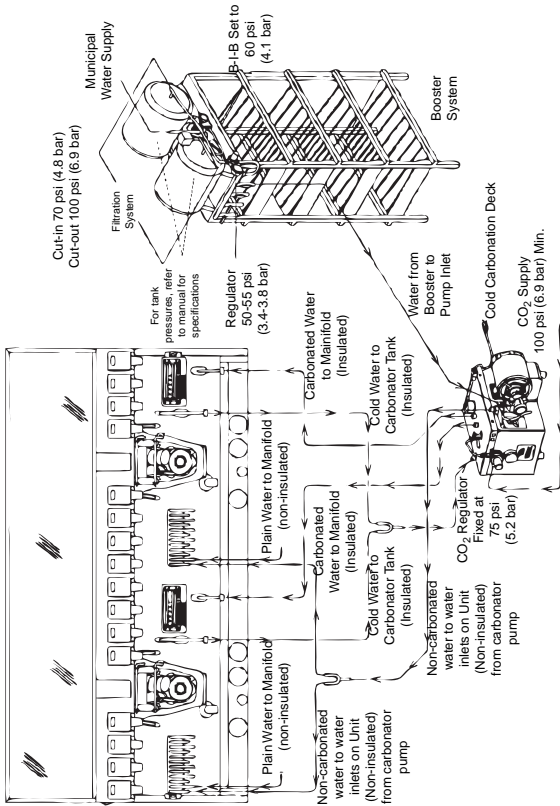

NOTE:

- Cold carbonator deck must be within 10 ft (3.05 m) of unit to function properly.
- Cold carbonation deck must be placed on a level surface.
- Cold carbonation deck requires booster system if supply water pressure is below 40 psi (2.8 bar), or if two units are installed on the same water line.
- filtration system may be placed before booster pump (per customer specifications).
- Items have been removed for clarity.
- 16 valve unit is shown.

Maintenance

Cleaning

ICE/BEVERAGE & COUNTER ELECTRIC DAILY CLEANING

All cleaning must meet your local health department regulations. The following cleaning instructions are provided as a guide.

 **Caution**

Use only warm soapy water to clean the exterior of the tower. Do not use solvents or other cleaning agents. Do not pour hot coffee into the drain pan. Pouring hot coffee down the drain pan can eventually crack the drain pan, especially if the drain pan is cold or still contains ice.

 **Warning**

Electric Shock Hazard

Unplug unit before servicing or cleaning.

 **Warning**

When using cleaning fluids or chemicals, rubber gloves and eye protection must be worn.

Clean the exterior and drain pan:

1. Turn off the key switch located on either right or left side of the unit.
2. Lift the grid and remove it from the drain pan.
3. Using mild soap, warm water and a clean cloth, wipe the drain pan and splash panel. Then, rinse with clean, warm water. Allow plenty of warm (not hot) water to run down the drain of the drain pan, to remove syrup residue that can clog the drain opening.

4. Wash the grid, then rinse with clean water. Place the grid back in the drain pan.
5. Wash all exterior surfaces of the unit with warm water and a clean cloth. Wipe again with a clean, dry cloth.

Clean the dispensing valves:

6. Remove nozzles and diffusers from beverage valves.

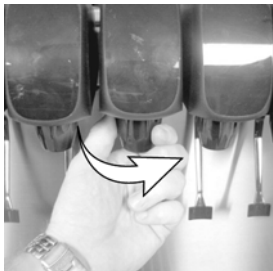

Nozzle Removal

NOTE: The Flav'R-Pic (FRP-250 and FRP-250SCI) model have different dispensing nozzles. Remove nozzles from each dispense point by (a) grasping it firmly and turning it clockwise about 1/4" (0.64 cm) then (b) pulling down.



7. Rinse nozzle and/or diffuser with warm, clean water.

8. Clean nozzles and diffusers with soapy water and a soft bristle brush.
9. Clean the underside of the beverage valves with warm, soapy water. Rinse with clean damp towel.
10. Replace nozzles and diffusers on valves.
11. Turn on the key switch.

ICE/BEVERAGE AND COUNTER ELECTRIC MONTHLY CLEANING



Warning

Unplug unit before servicing or cleaning ice bin. Ice bin contains parts that can move at any time and will cause injury if hands are in the way.



Warning

When using cleaning fluids or chemicals, rubber gloves and eye protection must be worn.

Clean and sanitize the ice bin:

1. Unplug unit and remove all ice from the ice bin.
2. Mix a solution of mild detergent to clean the dispenser bin and components.
3. Wash the ice bin using a sponge and the mild detergent solution.
4. Using the mild detergent solution and a soft bristle brush or clean cloth, clean the following dispenser parts:
 - Entire bin
 - Paddle wheel (Ice Dispensing Units)
 - Paddle wheel area (Ice Dispensing Units)
 - Agitator (Ice Dispensing Units)
 - Paddle wheel pin (Ice Dispensing Units)
 - Ice chute (Ice Dispensing Units)
 - Rear bushing (Ice Dispensing Units)

- Motor shaft (Ice Dispensing Units)
 - Strip lids (where applicable)
5. Rinse all the parts in clean, running water.
 6. Prepare 2 gallons (7.6 l) of sanitizing solution by mixing 1/2 ounce (14.2 g) of household bleach (that contains 5.25% sodium hypochlorite) with 2 gallons (7.6 l) of 120°F (48.9°C) water. The mixture must not exceed 100 PPM of chlorine. Or mix a solution of any approved sanitizer, following the directions for mixing and applying the sanitizer.
 7. Sanitize the ice bin and cold plate with the sanitizing solution for at least 10 seconds.
 8. Allow to air dry. Do not rinse.
- Re-assembling the dispenser parts:
9. Re-assemble parts in the following order:
 - Bin liner (Ice Dispensing Units)
 - Paddle wheel (Ice Dispensing Units)
 - Agitator (Ice Dispensing Units)
 - Paddle wheel pin (Ice Dispensing Units)
 - Ice chute (Ice Dispensing Units)
 - Merchandiser
 10. Hand tighten all knurled fasteners.
 11. Pour in fresh, sanitary ice and replace the plastic lid on the top of the dispenser.
 12. Plug in the unit's electrical cord.
 13. Check for proper ice dispensing.

CLEANING CHECKLIST

- Check CO₂ supply. If CO₂ supply is low, an arrow on the primary regulator gauge will point to a shaded area that reads “Low CO₂” or “Change CO₂ Cylinder.”
- Check syrup supply.
- Clean drain pan, grid, and splash panel.
- Clean the valve nozzles and diffusers.

CEV WATER BATH

It is recommended that the water bath be drained at least twice a year. Turn off the refrigeration. Completely melt the ice bank. Refill the water bath with fresh water until water runs out the overflow tube. Turn on the refrigeration.

Disassembly

DISASSEMBLY FOR CLEANING AND MAINTENANCE (ICE/BEVERAGE DISPENSERS)

NOTE: Sanitize the ice dispenser at Initial Start-up in addition to monthly sanitizing. You will need a slotted screwdriver in order to disassemble.

Disassemble parts in the following order:

- A. Merchandiser
- B. Ice chute
- C. Paddle wheel or agitator pins
- D. Agitator
- E. Paddle wheel
- F. Bin liner
- G. Paddle wheel area

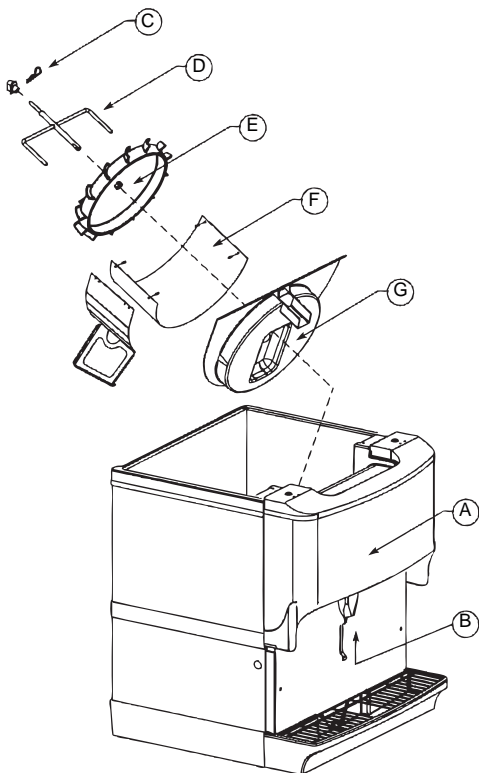

Beverage/Ice Dispenser

Accessing a Dispenser Bin Top Mounted with a Manitowoc Ice Machine:

1. Remove the front panel of the ice machine.
2. Remove the ice deflection baffle. This will give you access to the dispenser bin.
3. If the Manitowoc ice machine is operating, wait for the sheet of ice to fall into the dispenser bin.

When the ice sheet falls into the dispenser bin, immediately place toggle switch of the ice machine to the OFF position. If the Manitowoc ice machine is NOT operating, place the toggle switch of the ice machine to the OFF position.

4. On models without a top mounted ice machine, remove the plastic lid from the top of the dispenser.
5. Remove all ice from the dispenser.
6. Disconnect electrical power to the dispenser.
7. Remove agitator arm and paddlewheel pin.

Non-front Serviceable Motor

- a. Rotate the agitator arm so the paddle wheel pin handle is pointing up, toward the ceiling.
- b. Prepare agitator pin for removal by removing the stainless steel split ring.
- c. Then remove the paddle wheel pin from the hole in the agitator.
- d. Push the agitator bar toward the back of the unit until the agitator is free of the paddle wheel hub.

Front Serviceable Motor

- a. With agitator arm in any position remove hitch clip pin from the mushroom bushing on the rear of the ice bin.
- b. Push the agitator bar toward the bushing to remove it from the paddle wheel hub.

NOTE: If a top mount ice machine is installed, sliding the ice machine to one side will make bin component removal easier. If the ice machine is hard plumbed it will need to be disconnected.

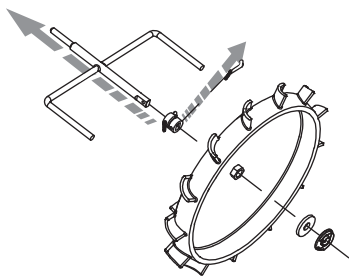

Non-front Serviceable

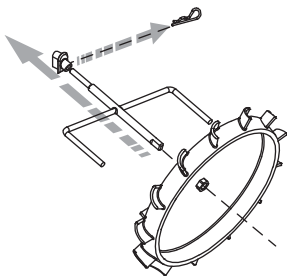

Front Serviceable

8. Remove paddle wheel, bin liner and paddle wheel area.
9. Move the front of the agitator to one side and slide the agitator forward until the rear of the agitator shaft is clear of the bushing.
10. Remove the agitator from the bin area.
11. Slide the paddle wheel from its shaft.
12. Loosen the four knurled fasteners that hold the bin liner in place.
13. Remove the bin liner.
14. Remove the paddle wheel area from the bin.
15. Discard the remaining ice in the bin.

DISASSEMBLE THE ROCKING CHUTE

NOTE: For all Quickdraw units, refer to the Quickdraw Components section for ice chute information.

1. Loosen the two knurled fasteners that hold the merchandiser in place.
2. Remove the merchandiser.
3. Remove outer bracket.
4. Remove door lock.
5. Remove door.
6. Remove ice chute.

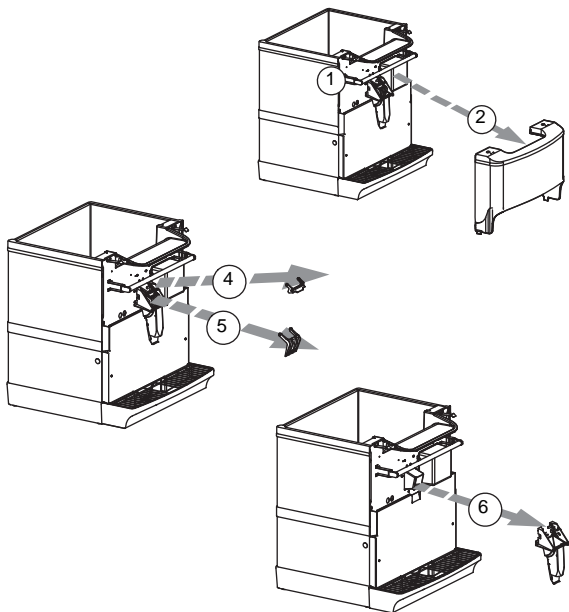

Ice Chute Removal

BLADE TOWER

How to Disassemble Tower Components

NOTE: This tower consists of two (2) valves combined as one (1) with a mixer block, mixer tube, and mixer. One pre-mix valve (CMBECKER) and one (1) Flomatic 424 flow control base.

Tower and Valve Disassembly:

1. Remove tower housing cover by removing the thumb screw on the side.
2. Turn OFF both shut-off valves on the flow control base and remove pressure by pulling the dispense handle to the ON position.
3. Remove the latch pin on the mixer block by pulling straight up.
4. Unscrew the inside flange nut on the pre-mix valve.
5. Remove the pre-mix valve and mixer tube out the front of the tower.
6. Remove the 424 flow control base by lifting up on its latch pin.

To reassemble follow these steps in reverse order.

Maintenance Schedule

Every day	Dispensing Valves	For the pre-mix dispensing valve, run carbonated water ONLY through the valve and dispense nozzle for 10 seconds. Turn syrup shut OFF, and block the dispense nozzle base with a clean new napkin. Dispense carbonated water only for a few seconds to fully fill the dispense nozzle. Then unblock the dispense nozzle and flow carbonated water for 10 seconds. Wipe external nozzle surfaces with carbonated water, then turn syrup shut off, ON. Clean other nearby surfaces with carbonated water or cleaning solution.
-----------	-------------------	--

Every day	Drip pan and drain hose	Wash with mild detergent. Rinse with clean water.
Every day	Quick disconnects	Wash with mild detergent. Rinse with potable water.
Weekly	Outside, dispenser cabinet	Wash with clean water and mild detergent. Wipe dry.
Every 3 months	Syrup circuits	Sanitize each syrup circuit. See "Cleaning and Sanitizing Procedure".
Every 3 months	Water bath	Drain, melt ice and clean using detergent and brush; rinse with potable water. Do not use water over 140°F (60°C).
Every 6 months	Condenser	Vacuum fins or use soft bristle brush (scrub brush).
Every 6 months	Air purifier filter (if equipped)	Replace.

Nightly Shutdown Procedure

It is recommended that the following steps are followed to keep your Blade Tower clean and running properly;

1. Remove tower top piece to gain access to the valves.
2. Turn the syrup shut off valve to the OFF position on all valves (2 valves per tower).
3. Dispense carbonated water for 10 seconds from all valves.
4. Leave valves off overnight and turn back on in the morning for use.

FLEXTOWER DAILY CLEANING

Cleaning the grid, splash shield and drain pan:

1. Turn off the on/off rocker switch located on left side of the unit.

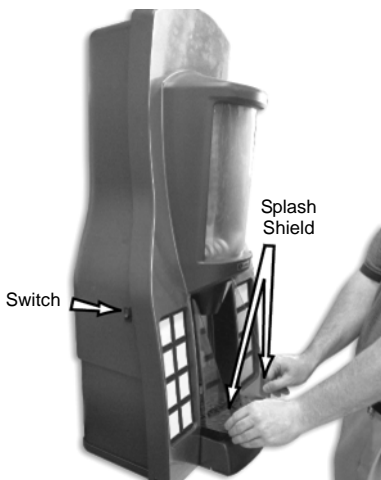

2. Lift the grid and splash shield to remove them from the drain pan.
3. Using mild soap, warm water and a clean cloth, wipe the drain pan. Then, rinse with clean, warm water. Allow plenty of warm (not hot) water to run down the drain of the drain pan, to remove syrup residue that can clog the drain opening.
4. Wash the grid and splash shield, then rinse with clean water. Place the grid and splash shield back in the drain pan.
5. Wash all exterior surfaces of the unit with warm water and a clean cloth. Wipe again with a clean, dry cloth.

Cleaning the water valve nozzle and diffuser, cosmetic nozzle and syrup injection shroud assembly:

6. Remove the cosmetic nozzle, and then remove nozzle-diffuser assembly from water valve.

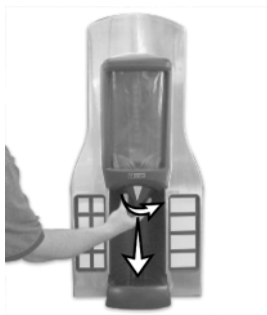

7. Rinse the cosmetic nozzle and water valve nozzle-diffuser assembly with warm, clean water.
8. Clean water valve nozzle-diffuser assembly with soapy water and a soft bristle brush.
9. Clean the cosmetic nozzle, underside of the water valve and the inside of the syrup injection shroud assembly with warm, soapy water. Rinse with clean warm towel.
10. Replace water valve nozzle-diffuser assembly and cosmetic nozzle.
11. Turn on the on/off rocker switch located on left side.

QUICKDRAW COMPONENTS

1. Turn the beverage valve switch on the front left side to the off position.



2. Place a receptacle (bucket or large cup) under the ice dispense chute.
3. Place the ice dispense switch to MANUAL mode. The door will open and ice will fall into the bucket or cup.
4. Remove the ice chute cover:
 - A. Grab the tabs on the back of chute and spread, pulling tabs off of pins.

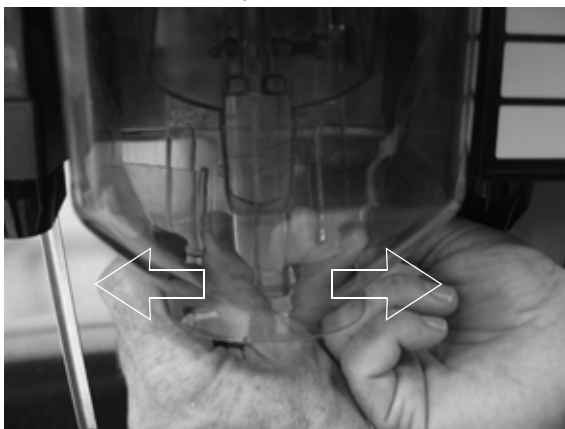

B. Push the bottom of chute to rear until it stops.



C. Rock top of the chute forward until top of chute clears unit.

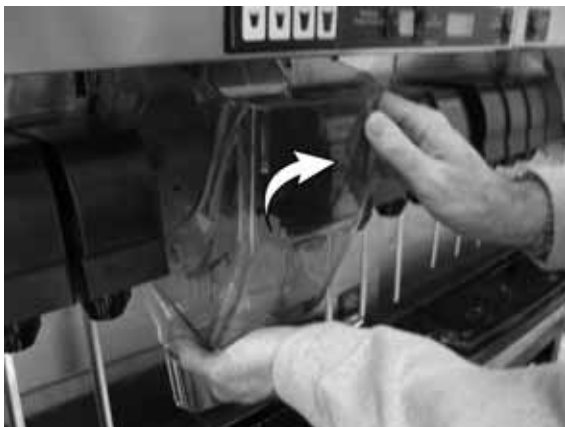

5. Remove ice wheel:

A. Pull cotter pin from the ice wheel axle.

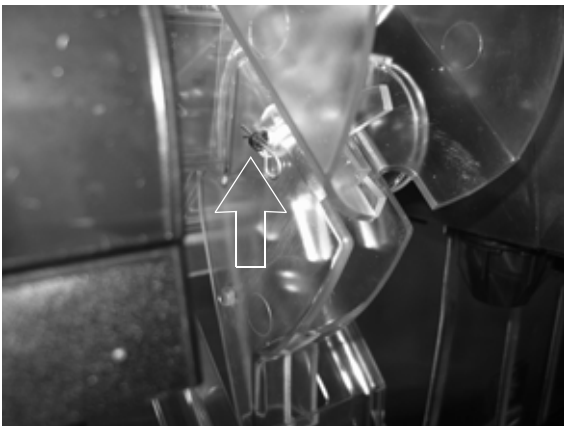

B. Grasp handle of the pin on the right side, pulling until the ice wheel is loose.



6. Mix a solution of mild detergent to clean the Quickdraw components. Using the detergent solution and a soft bristle brush or clean cloth, clean the following components:
 - Ice wheel
 - Cup locator
 - Quickdraw chamber
 - Door
 - Ice chute cover
7. Rinse all parts in clean running water.
8. Mix a sanitizing solution of 1/4 ounce (7.4 ml) liquid, unscented bleach (5.25% CL NaO concentration) for each gallon of water. The mixture must provide 100 PPM available chlorine.
9. Using the sanitizing solution, a soft bristle brush, or a clean cloth, sanitize the components listed in **Step 6**. The ice chamber must be sanitized with a soft bristle brush to adequately clean the metering wheel slot and drainage area.
10. Reverse the procedure to reassemble the Quickdraw mechanism.

NOTE: When inserting the pin through the ice wheel, you will have to align the pin with the pattern of the wheel hole.

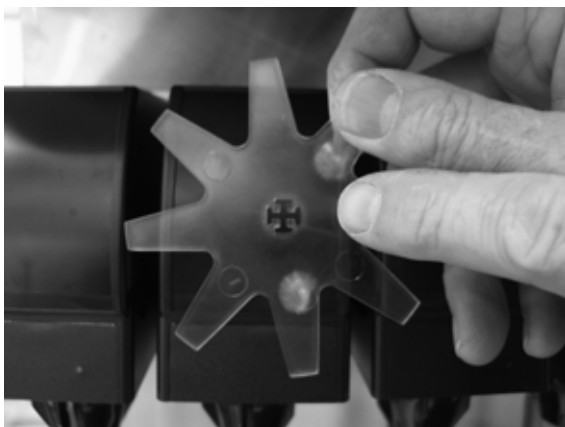

11. Place the ice dispense switch to the AUTO position, and place the beverage valve switch to the ON position.
12. Check for proper operation.

SELECTABLE ICE CRUSHER DISASSEMBLY

Before servicing or cleaning any part of the Selectable Ice unit be sure to unplug it from its power source. In order to access the module and crusher you must first remove the merchandiser by taking out the two screws located at the top of the merchandiser. Once the screws are removed, rotate the top of the merchandiser towards you and then lift the merchandiser up to remove from unit.

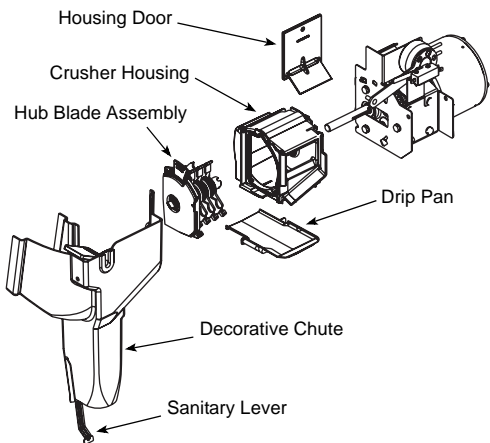

1. Unplug unit before cleaning or servicing the Crusher Assembly.
2. Remove the merchandiser by taking out the two screws located at the top of the merchandiser. Once the screws are removed rotate the top of the merchandiser towards you and then lift the merchandiser up to remove from unit.

NOTE: When the Merchandiser is removed an electrical safety switch disconnects power to the Ice Crusher assembly.

3. Remove the ice chute by pulling the cotter pin out on the right side of the chute rod and pulling the chute rod toward the left side of the dispenser.

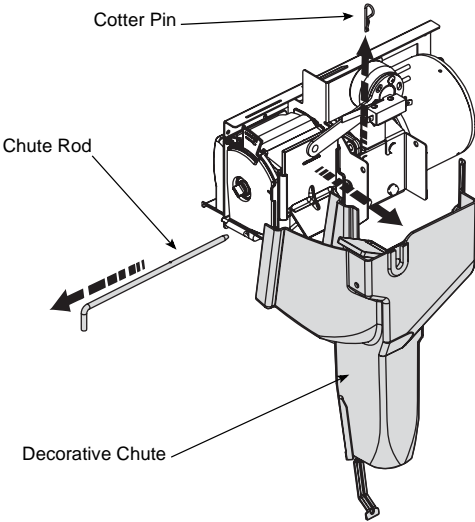

4. Remove the crushed ice and cube ice doors from the dispenser by lifting the solenoid arms up and pushing the doors back to disengage the door from the solenoid arm.

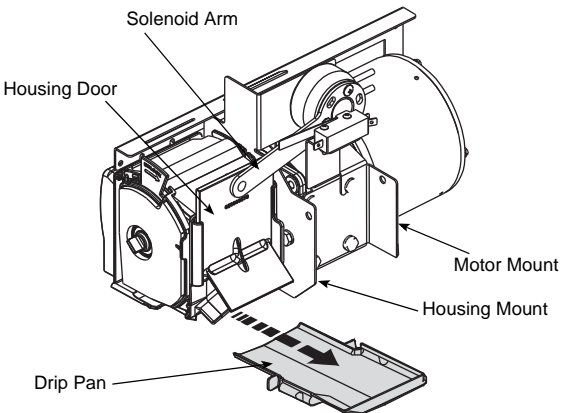

5. Remove the crusher drip pan by pulling it forward.
6. Remove the ice crusher blade assembly from the crusher housing.
 - A. Unlock the crusher hub/blade assembly from the crusher housing by pushing locking tab in, and rotating the hub/blade assembly clockwise.

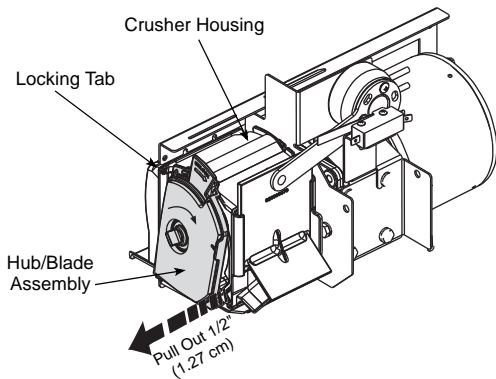

- B. Pull the hub/blade assembly out of the housing approximately 1/2" (1.27 cm) to disengage the crusher axle from the motor shaft.

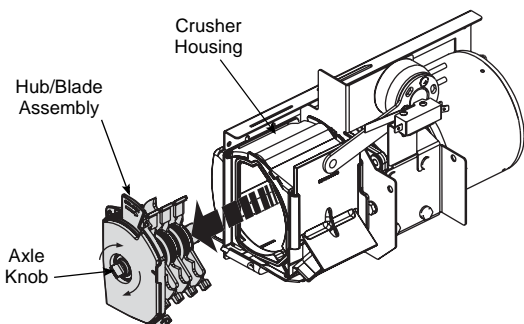

- C. Rotate the knob on the crusher axle so it is in a vertical position. (This will ensure the rotating blades will not interfere with pulling the hub/blade assembly from the housing.)
- D. Now the hub/blade assembly will be free from the housing and you will be able to completely remove the hub/blade assembly from unit.

REASSEMBLE THE ICE CRUSHER ASSEMBLY

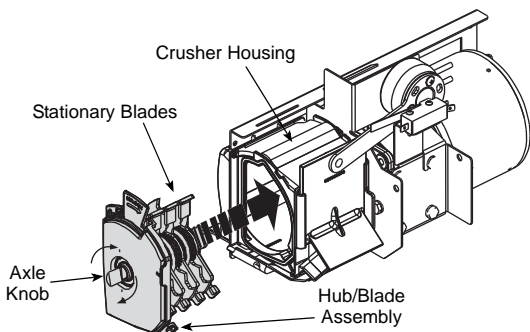

1. Insert the hub/blade assembly into the ice crusher housing. When inserting the hub/blade assembly you must align the stationary blades with the locating slots in the ice crusher housing.
2. When inserting the hub/blade assembly into the ice crusher housing you must also make sure the axle knob is in a vertical position. This will align the rotating blades with the housing to ensure a quick and easy installation.

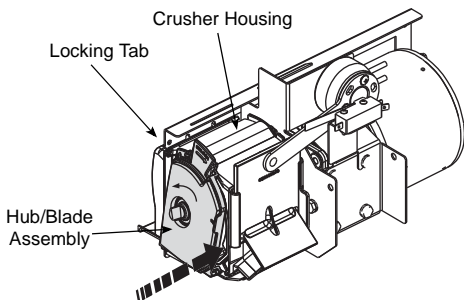

3. Once all blades are in the crusher housing you will need to align the crusher axle with the motor shaft. You can do this by turning the axle knob and pushing the blade assembly toward the motor until the hub/blade assembly is flush with the end of the crusher housing.

- To lock the hub/blade assembly into the housing, rotate the crusher hub/blade assembly counterclockwise until the locking tab snaps into place and the crusher hub/blade assembly is secure.
- Replace the crusher drip pan.

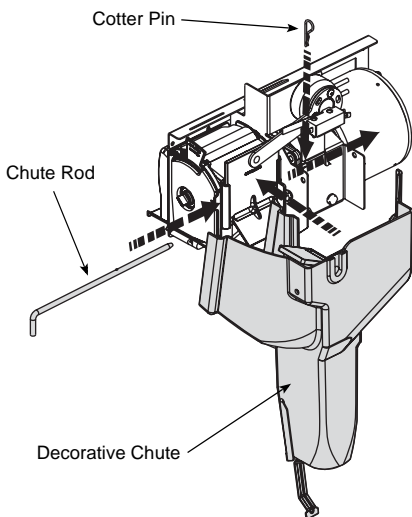

- Reattach the decorative ice chute by inserting the chute rod through the decorative chute, housing mount, and motor mount. Secure the chute rod by inserting the cotter pin through the rod on the right side of the chute.
- Ensure the extension at the top of the decorative chute is behind the arm of the activation switch.

Replacement

NON-FRONT SERVICEABLE GEAR MOTOR REMOVAL

These instructions are provided as a guide for the removal of the gear motor. Depending on the model number of your dispenser, these instructions may vary slightly.

1. Disconnect power from the electric receptacle.
2. Remove all ice from the ice storage bin of the dispenser.
3. Remove the paddle wheel pin from the paddle wheel/agitator assembly inside the dispenser bin.
4. Remove the agitator assembly from the dispenser bin by pushing the agitator to the back of the bin. Angle the front of the agitator to the side. Pull the agitator forward then out of the dispenser.
5. Remove the paddle wheel from the dispenser by pulling the hub of the paddle wheel to the back of the bin and off the gear motor shaft.
6. Remove the splash panel from the dispenser and expose the gear motor.
7. Disconnect the electric connector from the gear motor wire leads.
8. Remove the pin in front of the gear motor.
9. You must be able to remove the gear motor from the dispenser.

To install a replacement gear motor, reverse this procedure.

FRONT SERVICEABLE GEAR MOTOR REMOVAL

These instructions are provided as a guide for the removal of the gear motor. Depending on the model number of your dispenser, these instructions may vary slightly.

1. Unplug the dispenser.
2. Unplug the motor.
3. Remove motor mount pins.



4. Slide motor towards you.
5. Notice alignment of the chamfered edge of drive shaft.



6. New motor must have the same alignment (within 15 degrees).
7. To get correct alignment you can do one of two things:
 - a. Turn drive shaft with an adjustable wrench, being careful not to damage the drive shaft.
 - b. Plug in the unit, plug in the motor and use the ice dispense switch to move the drive shaft into correct alignment.
8. If you plugged in the unit to help with alignment of drive shaft now unplug the unit.
9. Slide motor up into housing, making sure that the tabs fit on the bracket.



10. Install motor mount pins.
11. Plug in motor.
12. Test unit.

Sanitizing

BEVERAGE SYSTEM CLEANING

Warning

Flush sanitizing solution from syrup system.
Residual sanitizing solution left in system could create a health hazard.

Warning

When using cleaning fluids or chemicals, rubber gloves and eye protection must be worn.

Sanitize the beverage system at initial start-up as well as regularly scheduled cleaning. The drain pan must be in place under soda valves, to carry away detergent and sanitizing agents that will be flushed through valves.

BAG-IN-BOX SYSTEM SANITATION

The procedure below is for the sanitation of one syrup circuit at a time. Repeat to sanitize additional circuits.

You will need the following items to clean and sanitize the Bag-in-Box (B-I-B) beverage system:

- Three (3) clean buckets
- Plastic brush or soft cloth
- Mild detergent
- Unscented bleach (5% Na CL O) or Commercial sanitizer
- Bag-In-Box bag connector

1. Prepare the following in the buckets:

- Bucket 1 — warm to hot tap water for rinsing.
- Bucket 2 — mild detergent and warm to hot water.

- Bucket 3 — mix a solution of unscented bleach (5% Na CL O) or commercial sanitizer and warm to hot water. Mixture must supply 100 PPM available chlorine (1/4 oz. [7.1 g] bleach to 1 gallon [3.8 l] water).
2. Disconnect the “syrup-line side” of the bag-in-box connector.



3. Rinse connector with warm tap water.
4. Connect syrup connector to B-I-B connector and immerse both into Bucket 1. A “bag-side” connector can be created by cutting the connector from an empty disposable syrup bag.



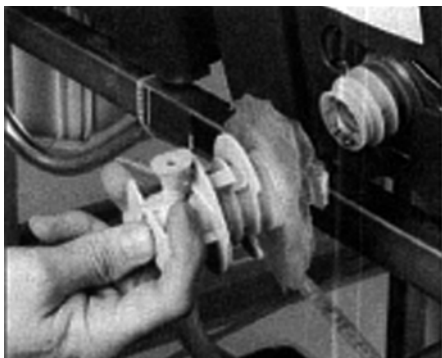

5. Draw rinse water through system until clean water is dispensed. Most beverage valves allow the syrup side to be manually activated by depressing the syrup pallet.
6. Connect Bucket 2 to system.
7. Draw detergent solution through system until solution is dispensed.
8. Repeat steps 2-7 until all syrup circuits contain detergent solution.
9. Allow detergent solution to remain in the system for 5 minutes.
10. Connect Bucket 3 to system.
11. Draw sanitizing solution through system until solution is dispensed.
12. Repeat step 11 until all syrup circuits contain sanitizer solution.
13. Allow sanitizer solution to remain in system for 15 minutes.
14. Remove nozzles and diffusers from beverage valves.
15. Scrub nozzles, diffusers and all removable valve parts (except electrical parts) with a plastic brush or a soft cloth and the detergent solution.
16. Soak nozzles, diffusers and removable valve parts (except electrical parts) in sanitizer for 15 minutes.

17. Replace nozzles, diffusers and valve parts.
18. Connect Bucket 1 to system.
19. Draw rinse water through system until no presence of sanitizer is detected.
20. Attach syrup connectors to B-I-Bs.
21. Draw syrup through system until only syrup is dispensed.
22. Discard first 2 drinks.

FIGAL BEVERAGE SYSTEM

1. Prepare the following in three clean Figal tanks:
 - **Rinse tank** - fill with room temperature tap water.
 - **Detergent tank** - mix approved beverage system cleaner with warm water as directed.
 - **Sanitizing tank** - mix a solution of unscented bleach (5% Na CL O) or commercial sanitizer and warm to hot water. Mixture must supply 100 PPM available chlorine (1/4 oz. [7.1 g] bleach to 1 gallon [3.8 l] water).
2. Disconnect all product and water lines from product tanks and remove carbonator.
3. Locate the Figal syrup tank for the circuit to be sanitized. Remove both quick disconnects from the Figal syrup tank. Rinse quick disconnects in tap water.
4. Connect rinse tank to the syrup line. Draw clean rinse water through the valve until syrup is flushed from the system.
5. Connect detergent tank to the syrup line and draw detergent through the valve for two minutes. Then, allow remaining detergent to stay in the system for five minutes.
6. Connect rinse tank to the syrup line. Draw clean rinse water through the valve until detergent is flushed from the system.

7. Remove valve nozzle and diffuser as shown in Daily Cleaning instructions. Using a plastic brush or a soft cloth and warm water, scrub the nozzle, diffuser, bottom of the dispensing valve and cup lever, if applicable.
8. Place removable valve parts (EXCEPT solenoids) in sanitizing solution for 15 minutes.
9. Replace valve diffuser and nozzle on the beverage valve.
10. Connect sanitizer tank to the syrup line and draw sanitizer through the valve for two minutes. Allow sanitizer to remain in the system for a minimum of 15 minutes.
11. Reconnect syrup and carbonated water lines.
12. Draw syrup through the lines to rinse the system. Discard drinks until at least two cups of satisfactory tasting beverage are dispensed through the valve.

Shipping, Storage and Relocation

Caution

Before shipping, storing, or relocating this unit, syrup systems must be sanitized. After sanitizing, all liquids (sanitizing solution and water) must be purged from the unit. A freezing environment causes residual sanitizing solution or water remaining inside the unit to freeze, resulting in damage to internal components.

This Page Intentionally Left Blank

Operation

Blade Tower Brixing

NOTE: Each tower consists of two valves combined as one with a mixer block, mixer tube and mixer. One Pre-ME valve (CMBEGKER) and one Flomatic 424 Flow Control Base



Set water flow rate first:

1. Turn off syrup shut-off at post-mix (424) valve block.
2. Use stop watch to time the dispense of soda water only.
3. Dispense for 5 seconds.
4. Record volume in a volume cup or ratio cup.
5. Adjust the water flow rate as needed until 10 ounces (283.5 g) of water is measured in a 5 second (2 oz [56.7 g]/sec) dispense.

Set the syrup flow rate:

1. Adjust the ratio (brix) of water to syrup (4.75:1) or 12.3 to 12.7 brix)
2. Turn on syrup shut-off and turn off the water shut-off.
3. Use a stop watch to time the dispense of syrup only.
4. Dispense for 5 seconds.
5. Record volume in a volume cup or ratio cup.
6. Adjust syrup flow rate as needed until 2 ounces (56.7 g) of syrup is measured in a 5 second dispense.
7. Use a refractometer if possible to get final brix ratio of 12.3 to 12.7. You will have to rely on volume adjustment above for diet products.

CEV Electronic Ice & Carbonation Control

Element	Function
<p>Voltage Selection Switch (Red Side Switch)</p>  = 115 Volt Position  = 230 Volt Position	<ul style="list-style-type: none"> Switch is used to select voltage, 115 Volt or 230 Volt option. When switch is in 115 Volt position the operating voltages are 100 Volts 50 Hertz and 120 Volts 60 Hertz. When switch is in 230 Volt position the operating voltages are 220-240 Volts 50 Hertz and 208-230 Volts 60 Hertz.
<p>On-Off Switch</p>	<ul style="list-style-type: none"> Switch supplies power to all control functions. When switch is in "on" position the agitation motor, transformer, merchandiser bulb and green power LED will be energized. (The green power LED will flash once per second for 5 seconds then stay on continuously.)
<p>Default Modes – LED/ Default (RED)</p> <ul style="list-style-type: none"> RED Carbonator LED = Default RED Compressor LED = Default 	<ul style="list-style-type: none"> If the carbonator motor run time exceeds the preset fill times, which are (3) minutes or (7) minutes. The default mode will shut power off to carbonator pump motor for (15) minutes. It will then activate for one minute and if the motor does not shut down within the one-minute time frame the (15) minute off time and (1) minute on time default mode will repeat. The process will occur a total of (4) times and then the unit will shut down, requiring service or a manual reset. Disconnecting the power supply from unit or positioning carbonator switch to the "off" position and then returning switch to "on" position will reset control to normal operation (only applies to Internal Carb. units) If the ice bank probe does not detect water in the CEV tub, the refrigeration will shut down and the compressor LED turns RED.

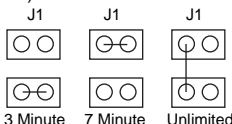
Element	Function
Carbonator Switch (Switch in OFF position for External Carb. and Juice units, which turns off green carbonator LED.)	<ul style="list-style-type: none"> Switch supplies power to the carbonator float switch and green Carbonator LED only.
Green Carbonator LED (Turned off on External Carb. and Juice Units)	<ul style="list-style-type: none"> The green carbonator LED illuminates when carbonator switch is in the ON position (only applies to Internal Carb. units). The green carbonator LED will flash rapidly when the carbonator motor is running.
Carbonator Fill Timing Jumper (Not used on External Carb. or Juice Units)	<ul style="list-style-type: none"> Carbonator tank fill timing provides pump failure protection in the event of water loss to carbonator pump (only applies to Internal Carb. units). A jumper clip within the control box sets the three optional time settings. Units are shipped with the jumper in (7) minute position (only applies to Internal Carb. units). <div style="text-align: center;">  <p style="text-align: center;"> J1 J1 J1 </p> <p style="text-align: center;"> 3 Minute 7 Minute Unlimited </p> </div> <p>NOTE: Time tolerance is $\pm 20\%$. NOTE: See default mode functions</p>
Green Compressor LED	<ul style="list-style-type: none"> Illuminates when the compressor switch is in the ON position. Flashes once per second when the compressor and condenser fan are energized.

Element	Function
Refrigeration Compressor Output	<ul style="list-style-type: none"> • There are three wires from the ice bank probe to the control box. The white wire connects to the low ice bank probe pin (probe pin nearest evaporator coil). All three probe pins must be immersed in water to initiate the refrigeration cycle. The refrigeration system will operate until the low ice bank probe pin and center ice bank probe pin (black wire to the control box) is covered by ice. The third ice bank probe pin (probe pin farthest from evaporator coil) is the common or ground pin. The common or ground ice bank probe pin (green wire to the control box) should always be immersed in water and never in ice of ice bank. • Note: A delay circuit is built into compressor and fan motor circuit. Delay is (4) minutes ($\pm 20\%$) and will prevent compressor start-up if there is a power loss to the unit or the compressor switch is in OFF position and then placed in ON position. Delay will also apply if refrigeration cycle is stopped on full ice bank and ice bank probe sends a faulty signal to restart refrigeration system within the (4) minute delay time.

Flavor Magic Programming

To exit the program mode at any time hold the program button for >3 seconds and the controller will switch to the dispense mode. The program mode can only be accessed by pressing the program button during the first five seconds of initial power up.

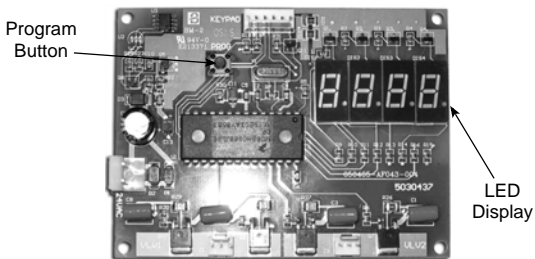

PROGRAM DISPENSE TIME

1. The program mode is used to adjust the dispense time. To access the Program Mode, disconnect power to the control board, wait ten seconds and reconnect power.
2. Press the program button one time on the control board during the first five seconds after power is applied.
3. The LED display will show "P r o". To check the current dispense time, press the corresponding flavor button on the touchpad and the time will be displayed on the LED (Example "1.0").
 - a. To increase the time (+) by two-tenths second increments press flavor button 1 (far left button).
 - b. To decrease the time (-) by two-tenths second increments press flavor button 3 (far right button).The default setting is one second.

PURGE/SANITIZE

Purge/Sanitize mode allows the user to purge air from the syrup lines during initial start-up. The second function of this mode is to energize the valves to move sanitizer through all syrup lines automatically.

Enter the Purge/Sanitize Mode by press the program button until “P – S” is displayed.

Pressing flavor button 1 (far left button) will activate a sequenced four second dispense that starts with flavor 1 then to flavor 2 etc. The valves will continue to cycle for 15 minutes or until the program button is pressed once.

DISPENSING MODES

Normal Dispense

With power applied to the control board, it will automatically start in dispense mode after a five second delay. The LED display will count down from four to zero and then show “- - -” while in dispense mode. Simply pressing the desired flavor on the touchpad dispenses Flavor Magic.

Flavor Counter

The flavor counter tracks the number of flavor shots dispensed per flavor. To access Flavor Counter Mode, press the program button on the control board once for at least three seconds. The LED display will show “C n t”. In the count mode the Flavor Magic module will not dispense. Check the number of dispenses for any flavor by pressing the corresponding touchpad button. To check another flavor press the program button once and then the corresponding flavor button on the touchpad. To return to dispense mode press the program button until the LED display shows “- - -”.

CHANGING NUMBER OF ACTIVE FLAVORS



To line up flavors with valves, note that valve outlets number from left to right 1...2...3...4. Touch pad flavor tab is numbered as shown below. Connect vinyl tube from outlet 1 and dispense with flavor tab 1, etc.

The current Flavor Magic control board is set up in the 4 flavor default mode. This mode will handle all dispensing situations whether 3 or 4 flavors are used. Some early boards were set up as default in the 3 flavor mode. If the customer desires to add another flavor for a total of 4, proceed as follows:

1. Power down the circuit board by disconnecting the 24 volt connector in the lower left hand side of the board. "24VAC" is imprinted on the board next to the pin connection.
2. Wait a minimum of 10 seconds.
3. Power up the board by connecting the 24 volt connector.
4. IMMEDIATELY (within 5 seconds) press and hold the "PROG" button down.
5. After a few seconds, the number "4" will appear on the display.
6. Release the "PROG" button. The board will cycle the display from "Pro" to "4.....3.....2.....1.....0" and then to "- - -".
7. The circuit board is now enabled to dispense the 4th flavor. The 4th flavor button is the top middle button.

8. A flavor tab for the 4th flavor will have to be added to the touch pad. To do this, obtain one (1) P/N [5030780](#) 20 flavor decal pad. Remove the P/N [5031579](#) decal overlay and add the 4th flavor tab as well as replace any flavor tabs which came off when removing the decal overlay. Note position of 4th flavor on the touch pad in the picture and placed tab where indicated. Obtain a new P/N [5031579](#) decal overlay and place over the tabs.

If the customer decides to go back to 3 flavors, it will not be necessary to change the board back to 3 flavors. However, it can be done by following steps 1 through 6 above. The number “3” will appear on the display. Then disconnect the number “4” syrup from the system, remove the [5031579](#) decal overlay, remove the flavor tab “4” and replace the [5031579](#) decal overlay. It would be a good idea to have an additional P/N [5030780](#) in case flavor tabs are damaged in the process.

STEADY OR FLASHING TOUCH PAD LED

The blue LED on the touch pad can be set to one of two display modes:

1. Steady illumination. This is the default mode and the LED will remain on steady until dispense is activated. The light will flash only when product is being dispensed. In this mode, the control board display will read “Off”.
2. Flash mode. The LED will turn on for 1/2 second and off for 1/2 second.

Enter the Flash mode by pressing the program button until a flashing “- - -” is displayed. Pressing flavor button 1 (far left button) will switch from “Off” (default) to “On”. The LED will now flash. To change back to the default simply press flavor button 1 again and the display should read “Off”. Press program button to exit to the next program function.

TIME DELAY AFTER DISPENSE

A time delay can be programmed into the control board which will prevent the system from dispensing another flavor for a period of from 0 to 10 seconds following a dispense. The default is 0 seconds.

Enter the Time Delay mode by pressing the program button until "d L A Y" is displayed. To check the current delay time press any flavor button one time and the current value will be displayed. To increase the time (+) by 1.0 second increments press flavor button 1 (far left button). To decrease the time (-) by 1.0 second increments press flavor button 3 (far right button).

Flav'R-Pic External Programming

HOW TO CHECK FRP BRIX EXTERNALLY

If your FRP-250 has a control board with the external brix check ability you will be able to put the unit into brix mode by doing the following:

1. Turn the keyswitch to the "OFF" position.
2. With the keyswitch still in the "OFF" position, press and hold the F1 touch pad button for the left side or F5 for the right while turning the keyswitch back to the "ON" position.
 - F1 = Left Side Brix Check
 - F5 = Right Side Brix Check

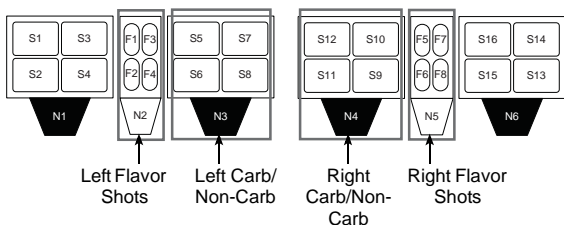

FRP-250 with Flavor Shots

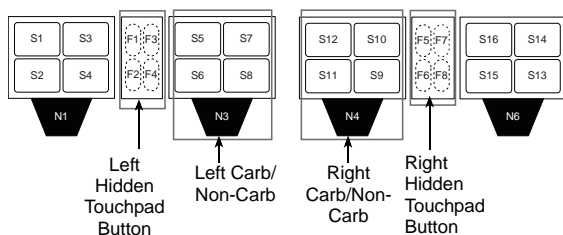

FRP-250 with out Flavor Shots

NOTE: The buttons for FRP units without flavor shots are located in the same area, but are hidden.

3. You can now stop pressing on the F1 or F5 button and the 4 LEDs around the touch pad area should now be illuminated. If not illuminated you did not successfully go into external brix mode and need to try again, or the FRP unit is not equipped with this program mode.

In this setting when a corresponding touch pad is pressed water or syrup will be dispensed for a fixed duration in order to check your ratios using a standard brix cup.

4. In this mode you can now check the brix for any water or syrup valve that corresponds to the board. Use the illustration in Installation/Brixing or the Control board, Valve, Touch Pad Matrix to identify the valves and which board they correspond to. Brixing information can also be found on the unit, on the right hand side of the control board cover label. By using this label in combination with the plumbing label located on the foam front you will be able to identify each valve, water, and/or syrup combination.
5. When finished checking the brix return the unit to dispense mode by turning the keyswitch to the "OFF" position, waiting till the touch pad LEDs are not illuminated, then turn the keyswitch back to the "ON" position.

Important

If left in external brix mode for longer than 5 minutes it will automatically time out and return to dispense mode.

If brix adjustments are needed you will have to remove the merchandiser to make the mechanical adjustments. Please see PROGRAM MODE 2 in this section for internal brixing instructions using the control board and the Brixing Procedure for detailed instructions on brixing the FRP-250.

CRUSHED OR CUBED DEFAULT

This selectable ice option will allow the unit to always default to either cube or crushed ice or remain at the last selection. This only applies to control boards 020000875 Rev 7 and up.

How to set default ice dispense setting

CUBE DEFAULT

1. Power on the unit by plugging in receptacle and holding the cube button at the same time, cube will flash 2 times. Unit will now change to cube 10 seconds after crush is selected.

CRUSH DEFAULT

2. Power on the unit by plugging in receptacle and holding the crushed button at the same time, crush will flash 2 times. Unit will now change to crush 10 seconds after cube is selected.

LAST SELECTION DEFAULT

3. Power on the unit by plugging in receptacle and holding cube and crush at the same time, cube and crush will flash 2 times. Unit will now remain in selection of last request.

NOTE: If power is lost to the unit and then powered up again the unit will retain the last setting and not return to factory settings.

Flav'R-Pic (FRP-250) Programming

PROGRAM MODE 1

Carb/Non-Carb & Flavor Shot Duration Settings

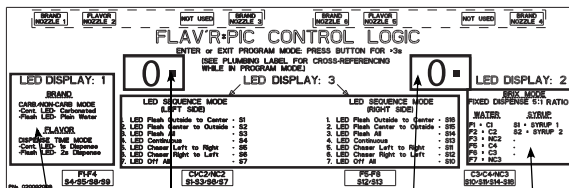

Mode 1 Carb/
non-Carb and
Flavor Shot
Durations

Left Side
Program
Button

Right Side
Program
Button

Bringing
Info

Mode 1 displayed above, allows you to select your carb/non-carb settings for dispense points N3 (Nozzle 3) through the left control board and/or N4 (Nozzle 4) with the right control board. Only nozzles N3 and N4 have the option to be a non-carb drink, N1 and N6 are carbonated only. Mode 1 is also used to set a 1 or 2 second dispense duration for flavor shots on N2 and N5 using their corresponding control board.

N3 & N4 Carbonated or Non-Carbonated Drinks

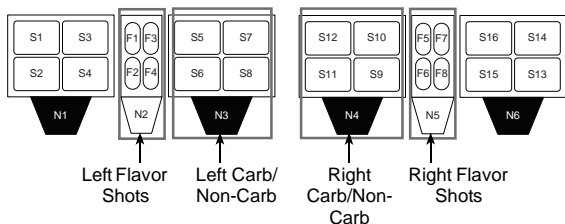

FRP-250 with Flavor Shots

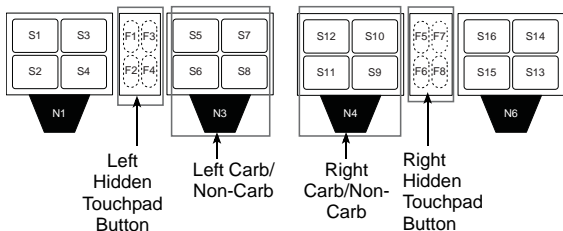

FRP-250 with out Flavor Shots

1. Choose a control board. If programming N3 (Nozzle 3) use the left control board, if programming N4 use the right control board. Beverage dispense points are designated by a black nozzle.
2. Press the program button and hold for 3 seconds or until the LED displays 1.
3. To set a carbonated drink for N3 (Nozzle 3) touch one of the following touch pads; S5, S6, S7, or S8 until the LEDs around the touch pad are constant.
4. To set a non-carbonated drink for N3 (Nozzle 3) touch one of the following touch pads; S5, S6, S7, or S8 until the LEDs around the touch pad are blinking.
 - Constant LEDs = Carbonated
 - Blinking LEDs = Non-Carbonated
5. Follow the same instructions for N4 (Nozzle 4) using the right control board and touch pads S9, S10, S11, or S12.
6. When you are finished, press the program button to go to a different mode or save your settings and return the control board to the dispense mode by pressing the program button and holding for 3 seconds or until the LED displays 0.

Flavor Shot Dispense Duration

1. Choose a control board. If programming flavor shots for N2 (Nozzle 2) use the left control board, if programming shots for N5 use the right control board. Flavor shot dispense points are designated by a blue nozzle.
2. Press the program button and hold for 3 seconds or until the LED displays 1.
3. To set a 1 second shot for N2 (Nozzle 2) touch one of the following touch pads; F1, F2, F3, or F4 until the LEDs around the touch pad are constant.
4. To set a 2 second shot for N2 (Nozzle 2) touch one of the following touch pads; F1, F2, F3, or F4 until the LEDs around the touch pad are blinking.
 - Constant LEDs = 1 second shot
 - Blinking LEDs = 2 second shot
5. Follow the same instructions for N5 (Nozzle 5) using the right control board and touch pads F5, F6, F7, or F8.
6. When you are finished, press the program button to go to a different mode or save your settings and return the control board to the dispense mode by pressing the program button and holding for 3 seconds or until the LED displays 0.

PROGRAM MODE 2

Brixing

Mode 2 displayed above, puts your Flav'R-Pic into brix mode. In this setting when a corresponding touch pad is pressed, water or syrup will be dispensed for a fixed duration in order to set your ratios using a standard brix cup and making adjustments to the mechanical valves. Follow the steps below to put a board into brix mode.

1. Choose a control board. If brixing drinks for N1 (Nozzle 1) or N3 use the left control board, if brixing drinks for N3 or N6 use the right control board. Beverage dispense points are designated by a black nozzle.
2. Press the program button and hold for 3 seconds or until the LED displays 1. Press the program button again until 2 is displayed on the control board LED display.

NOTE: Programming one board at a time will make it easier for you to identify the corresponding valves and dispense points.

3. With the a board in Mode 2, you can now brix any water or syrup valve that corresponds to the board. Use the illustration in Installation/Brixing or the Control board, Valve, Touch Pad Matrix to identify the valves and which board they correspond to. Brixing information can also be found on the unit, on the right hand side of the control board cover label. By using this label in combination with the plumbing label located on the foam front you will be able to identify each valve, water, and/or syrup combination.
4. Replace the nozzle when done then move on to another nozzle or, if you are finished brixing, return the control board to the dispense mode by pressing the program button and holding for 3 seconds or until the LED displays 0.

A brixing break down for each nozzle is available in the Brixing Procedure section of this manual.

PROGRAM MODE 3

Light Sequences

Mode 3 displayed above, allows you to set the light sequence for the touch pad LEDs. Follow the steps below to place the board into this mode and set sequences.

1. Choose a control board. If setting the light sequence for the touch pad area on the left use the left control board, or if you are setting them for the right, use the right control board.
2. Press the program button and hold for 3 seconds or until the LED displays 1. Press the program button again until 3 is displayed on the control board LED display.
3. With the left control board in mode 3 you can now choose one of the seven touch pad LED lighting sequences by pressing one of the following touch pad areas:
 - S1 = Flash outside to center
 - S2 = Flash center to outside
 - S3 = Flash all
 - S4 = Continuously on all
 - S5 = Chaser left to right
 - S6 = Chaser right to left
 - S7 = Off all
 - S8 = Flash outside to center, Flavor Shot Off

NOTE: It is recommended that both boards be set to the same lighting sequence. If not, the boards will not be able to sync and lighting behavior may become erratic.

4. With the right control board in mode 3 you can now choose one of the seven touch pad LED lighting sequences by pressing one of the following touch pad areas:
 - S16 = Flash outside to center
 - S15 = Flash center to outside
 - S14 = Flash all
 - S13 = Continuously on all

S12 = Chaser left to right

S11 = Chaser right to left

S10 = Off all

S9 = Flash outside to center, Flavor Shot Off

Important

When installed on a FRP without flavor shots the lighting sequence S8 & S9 should be used. All other units are set to S1 & S16 by default.

- When done move on to another programming mode or, if you are finished, return the control board to the dispense mode by pressing the program button and holding for 3 seconds or until the LED displays 0.

CONTROL BOARD TIME OUT

Important

If a control board is left in any program mode for longer than 5 minutes it will automatically time out and return to dispense mode 0. In order to enter back into a program mode you will need to press the program button and hold for 3 seconds or until the LED displays 1 again.

Flav'R-Pic (FRP-250) Brising Procedure

NOTE: This procedure is for flavors requiring 5:1 water to syrup ratio.

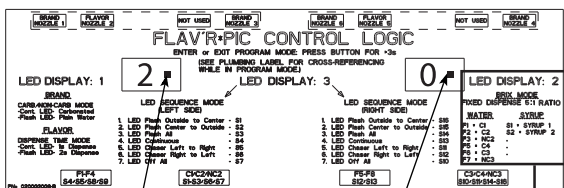

Left Side
Program
Button

Right Side
Program
Button

Brising
Info

Control Board Label

PLACING A CONTROL BOARD INTO BRIX MODE

NOTE: See Program Mode 2 for Program Mode Operations.

1. Prior to brixing be sure all water and syrup lines are connected to the system and purged. Ensure that syrup and water are available.
2. If the merchandiser and splash panel are on the front of the unit, remove them. Merchandiser removal will give you access to the syrup and water valves. Splash panel removal will give you access to the plumbing label located on the foam front and/or see the Diagrams section of this manual. This label will be needed to identify valve and touch pad locations.

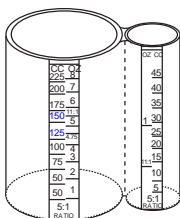

5:1 Brix Cup

3. Use a standard brix cup with a 5:1 ratio for the procedure. An example is illustrated above. Use of a funnel between the cup and nozzle may aid in the capture of the syrup during syrup brixing.

	Left Board	Right Board
Dispense Type and Valve Number	C1 - Valve 8	C3 - Valve 4
	C2 - Valve 11	C4 - Valve 1
	NC2 - Valve 11	NC3 - Valve 4
	S1 - Valve 8	S9 - Valve 15
	S2 - Valve 9	S10 - Valve 3
	S3 - Valve 9	S11 - Valve 3
	S4 - Valve 14	S12 - Valve 7
	S5 - Valve 14	S13 - Valve 7
	S6 - Valve 10	S14 - Valve 2
	S7 - Valve 10	S15 - Valve 2
	S8 - Valve 15	S16 - Valve 1
	F1 - Valve 13	F5 - Valve 6
	F2 - Valve 13	F6 - Valve 6
	F3 - Valve 12	F7 - Valve 5
	F4 - Valve 12	F8 - Valve 5
	C = Carb NC = Non-Carb S = Syrup F = Flavor Shot	

4. Locate the control board that corresponds with the valve(s) and/or dispense point you want to brix.
5. Press the program button and hold for 3 seconds or until the LED displays 1. Press the program button again until 2 is displayed on the control board LED display.

NOTE: Programming one board at a time will make it easier for you to identify the corresponding valves and dispense points. See Flav'R-Pic External Programming in this manual for more detail on all programming modes.

6. With a board in Mode 2 you can now brix any water or syrup valve that corresponds to the board. Use the chart above to identify the valves and which board they correspond to. See the illustration that follows for more assistance. Brixing information can also be found on the right hand side of the control board cover label. By using this label in combination with the plumbing label you will be able to identify each valve, water, and/or syrup combination.

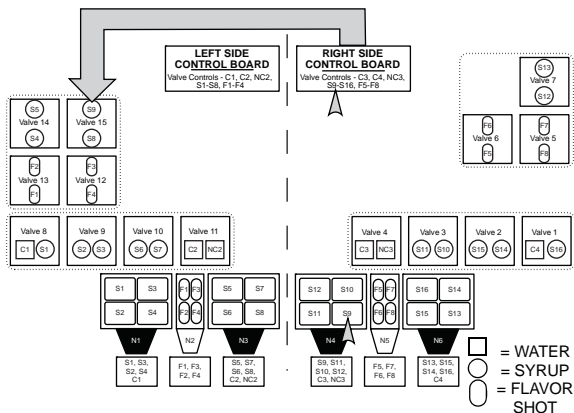

S9 (Syrup 9) on Valve 15 is the only syrup that does not correspond to the side it is mounted to. Both visually and functionally all other valves, touch pads, and dispense points correspond with the board on the same side to which they are attached.

GENERAL BRIXING PROCESS

1. With the corresponding control board set to brix mode and displaying a 2 you may brix a beverage nozzle (N1, N3, N4, or N6). If brixing a syrup, the use of a funnel between the cup and nozzle may aid in the capture of the syrup. (See nozzle order below.)

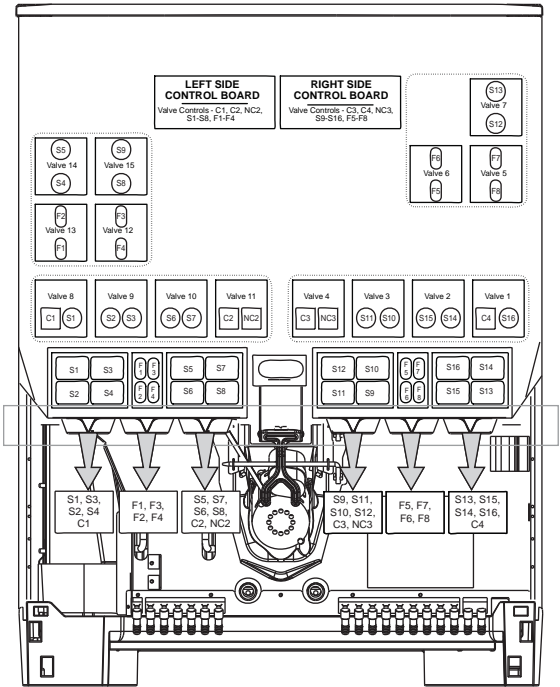

Nozzles from left to right: N1, N2, N3, N4, N5, N6

2. To brux carbonated or non-carbonated water for a dispense point, leave the nozzle in place and hold the brux cup with the water side of the cup under the nozzle area. Non-carbonated water is only available at N3 (Nozzle 3) and N4.
3. By referencing the control box label and plumbing diagram, press the flavor shot touch pad that corresponds with the water you wish to brux. If bruxing the left side, it will be one of the following; F1 (Flavor Shot 1), F2, or F3. When bruxing the right side, F5, F6, or F7 will be used. On non-flavor shot units, the touch pads are located behind the merchandiser on the foam front.

4. The correct volume should be 5 oz. (147.86 cc) during the fixed dispense in Mode 2. If adjustment is needed to attain this volume, make adjustments to the left side of valve 8 (C1) adjustment screw as needed until flow rate is satisfactory.

NOTE: The touch pad mount can be tilted forward in order to give you better access to the valves.

5. For syrup brixing place the brix cup with the syrup side of the cup under the nozzle area and press any brand touch pad area associated with that nozzle dispense point. For example S1 (Syrup 1), S2, S3, and S4 touch pad areas will be used to brix N1 (Nozzle 1).
6. Syrup will dispense for a fixed duration and should be even with the 5 oz. (147.86 cc) water mark on the cup, or 1 oz (29.57cc) just below the 30cc mark on the syrup side of the brix cup.
7. Check each syrup position and adjust syrup on the corresponding valve as necessary. A plumbing label is located on the foam front of the unit showing the position of each valve and syrup port. See the plumbing diagram.
8. When finished, move on to another nozzle or, if your brixing is complete, return the control board to the dispense mode by pressing the program button and holding for 3 seconds or until the LED displays 0. Replace the splash panel and merchandiser.

Nozzle 1 (N1) Water & Syrup Brixing

1. With the left control board set to brix mode and displaying a 2 you can now brix the carbonated water for N1 (Nozzle 1) located at the far left hand side of the unit.
2. To brix the carbonated water for this dispense point leave the nozzle in place, hold the brix cup with the water side of the cup under N1 (Nozzle 1), and press the F1 (Flavor Shot 1) button. Water will dispense for a fixed duration.
3. The correct volume should be 5 oz. (147.86 cc). If adjustment is needed to attain this volume, make adjustments to the left side of valve 8 (C1) adjustment screw as needed until flow rate is satisfactory.
4. For syrup brixing place the brix cup with the syrup side of the cup under the N1 and press the touch pad area for S1 (Syrup 1), S2, S3, or S4, and the corresponding syrup will dispense for a fixed duration.
5. Syrup should be even with the 5 oz. (147.86 cc) water mark on the cup, or 1 oz (29.57cc) just below the 30cc mark on the syrup side of the brix cup.
6. Check each syrup position and adjust syrup on the corresponding valve as necessary. A plumbing label is located on the foam front of the unit showing the position of each valve and syrup port. See the plumbing diagram.
7. Move to another nozzle or, if you are finished brixing, return the control board to the dispense mode by pressing the program button and holding for 3 seconds or until the LED displays 0. Replace the splash panel and merchandiser.

Nozzle 2 (N2) Water & Syrup Brixing

This is a flavor shot dispense point, designated so by its blue nozzle, no brixing is needed. Either a 1 or 2 second dispense duration can be selected in program Mode 1 from the left side control board. (See Flav'R-Pic External Programming for more information.)

Nozzle 3 (N3) Carb/Non-Carb Water & Syrup Brixing

1. With the left control board set to brix mode and displaying a 2 you can now brix carbonated or non-carbonated water for N3 (Nozzle 3). (See Program Mode 1 to designate carb/non-carb.)
2. To brix the carbonated water for this dispense point, leave the nozzle in place, hold the brix cup with the water side of the cup under N3 (Nozzle 3), and press the F2 (Flavor Shot 2) button. Carbonated water will dispense for a fixed duration.
3. To brix the non-carbonated water for this dispense point leave the nozzle in place, hold the brix cup with the water side of the cup under N3 (Nozzle 3), and press the F3 (Flavor Shot 3) button. Water will dispense for a fixed duration.
4. The correct carb and non-carb volume should be 5 oz. (147.86 cc). If adjustment is needed to attain this volume, make adjustments to the left side of valve 11 (C2) adjustment screw for carbonated water and the right side of valve 11 (NC2) adjustment screw for non-carbonated water as needed until flow rate is satisfactory.
5. For syrup brixing place the brix cup with the syrup side of the cup under the N3 (Nozzle 3) and press the touch pad area for S5 (Syrup 5), S6, S7, or S8 and the corresponding syrup will dispense for a fixed duration.
6. Syrup should be even with the 5 oz. (147.86 ml) water mark on the cup, or 1 oz (29.57cc) just below the 30cc mark on the syrup side of the brix cup.

7. Check each syrup position and adjust syrup on the corresponding valve as necessary. A plumbing label is located on the foam front of the unit showing the position of each valve and syrup port. See the plumbing diagram.
8. Move to another nozzle or, if you are finished brixing, return the control board to the dispense mode by pressing the program button and holding for 3 seconds or until the LED displays 0. Replace the splash panel and merchandiser.

Nozzle 4 (N4) Carb/Non-Carb Water & Syrup Brixing

1. With the right control board set to brix mode and displaying a 2, you can now brix carbonated or non-carbonated water for Nozzle 4 (N4). (See Program Mode 1 to designate carb/non-carb.)
2. To brix the carbonated water for this dispense point, leave the nozzle in place, hold the brix cup with the water side of the cup under N4 (Nozzle 4), and press the F6 (Flavor Shot 6) button. Water will dispense for a fixed duration.
3. To brix the non-carbonated water for this dispense point, leave the nozzle in place, hold the brix cup with the water side of the cup under N4 (Nozzle 4), and press the F7 (Flavor Shot 7) button. Water will dispense for a fixed duration.
4. The correct carb and non-carb volume should be 5 oz. (147.86 ml). If adjustment is needed to attain this volume, make adjustments to the left side of valve 11 (C3) adjustment screw for carbonated water and the right side of valve 4 (NC3) adjustment screw for non-carbonated water as needed until flow rate is satisfactory.
5. For syrup brixing place the brix cup with the syrup side of the cup under the N4 (Nozzle 4) and press the touch pad area for S9 (Syrup 9), S10, S11, or S12 and the corresponding syrup will dispense for a fixed duration.
6. Syrup should be even with the 5 oz. (147.86 cc) water mark on the cup, or 1 oz (29.57cc) just below the 30cc mark on the syrup side of the brix cup.

7. Check each syrup position and adjust syrup on the corresponding valve as necessary. A plumbing label is located on the foam front of the unit showing the position of each valve and syrup port. See the plumbing diagram.
8. Move to another nozzle or, if you are finished brixing, return the control board to the dispense mode by pressing the program button and holding for 3 seconds or until the LED displays 0. Replace the splash panel and merchandiser.

Nozzle 5 (N5) Water & Syrup Brixing

This is a flavor shot dispense point, designated so by its blue nozzle, no brixing is needed. Either a 1 or 2 second dispense duration can be selected in program Mode 1 from the right side control board. (See Flav'R-Pic External Programming for more information.)

Nozzle 6 (N6) Water & Syrup Brixing

1. With the right control board set to brix mode and displaying a 2 you can now brix the carbonated water for N6 (Nozzle 1) located at the far right hand side of the unit).
2. To brix the carbonated water for this dispense point, leave the nozzle in place, hold the brix cup with the water side of the cup under N6 (Nozzle 6), and press the F5 (Flavor Shot 5) button. Water will dispense for a fixed duration.
3. The correct volume should be 5 oz. (147.86 cc). If adjustment is needed to attain this volume, make adjustments to the left side of valve 1 (C4) adjustment screw as needed until flow rate is satisfactory.
4. For syrup brixing place the brix cup with the syrup side of the cup under the N6 (Nozzle 6) and press the touch pad area for S13 (Syrup 13), S14, S15, or S16, and the corresponding syrup will dispense for a fixed duration.
5. Syrup should be even with the 5 oz. (147.86 cc) water mark on the cup, or 1 oz (29.57cc) just below the 30cc mark on the syrup side of the brix cup.

6. Check each syrup position and adjust syrup on the corresponding valve as necessary. A plumbing label is located on the foam front of the unit showing the position of each valve and syrup port. See the plumbing diagram.
7. Move to another nozzle or, if you are finished brixing, return the control board to the dispense mode by pressing the program button and holding for 3 seconds or until the LED displays 0. Replace the splash panel and merchandiser.

FlexTower Programming Modes

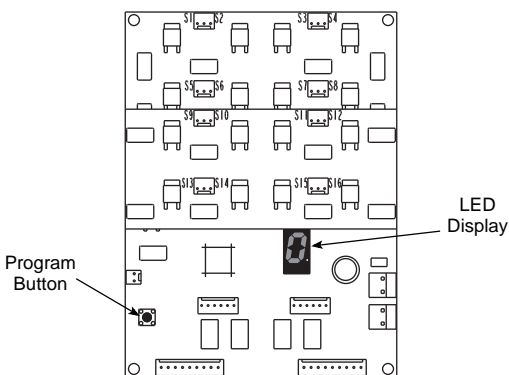

CONTROL BOARD RUN OR DISPENSE MODE

(Control Board LED Displays 0)

For finished drink, press and hold any labeled finished drink touchpad area to manually dispense a finished noncarbonated drink (all touchpad areas are defaulted from factor to manual dispense mode). For flavor adder, press any labeled flavor adder touchpad area and a one shot stored timed dispense will occur (dispense time of flavor adder can be changed in program mode 2).

THE 6 PROGRAMMING MODES ON FLEXTOWER CONTROL BOARD

Program Mode 1= Manual Dispense Mode

Program Mode 2= Timed Dispense Mode or Flavor Adder Mode

Program Mode 3= Water Calibration Mode

Program Mode 4= Syrup Calibration Mode

Program Mode 5= Touchpad Configuration Mode

Program Mode 6= Touchpad LED Light Sequencing Mode

To Access Programming Modes

To enter programming modes, press and hold the control board program button for a minimum of 3 seconds. Control board LED displays a number (1) for manual dispense mode. To select another programming mode, press and release the control board program button once to enter the next programming mode. Repeat pressing and releasing the control board program button until desired program mode is entered.

To Exit Programming Modes

To exit programming modes and to save programming mode changes, press and hold control board program button for a minimum of 3 seconds. Control board LED displays (0) for run or dispense mode.

Manual Dispense Mode

(Finished Noncarbonated Drink Dispensed)

Once in program mode (1), the control board LED displays (1). Press any touchpad selection area two times in less than three seconds and selection area LED lights will blink twice to indicate the touchpad area has been programmed for manual dispense. The procedure can be repeated for other touchpad selection areas needing programmed for manual dispense. After all designated touchpad areas have been programmed for manual dispense either enter another program mode or exit the programming modes, which will save programming mode changes.

Timed Dispense Mode (Flavor Adder Dispensed)

Once in program mode (2), the control board LED displays (2). Press any touchpad selection area three times in less than three seconds and selection area LED lights will blink three times to indicate the touchpad area has been programmed for timed dispense. Then the first and last touchpad selection areas will illuminate, which will allow increasing the timed dispense cycle by .2 seconds each press of the last illuminated touchpad selection area or decreasing the timed dispense cycle by .2 seconds each press of the first illuminated touchpad selection area. To program another touchpad area for timed dispense, press and release the control board program button to reset the timed dispense programming mode, first and last touchpad areas are no longer illuminated. Repeat procedures for programming timed dispense for other designated touchpad selection areas. After all designated touchpad areas have been programmed for timed dispense, either enter another program mode or exit the programming modes, which will save programming mode changes.

Water Calibration Mode

Once in program mode (3), the control board LED displays (3). Press any touchpad selection area and the noncarbonated water valve will dispense for three seconds in order to brix the valve. The procedure can be repeated as many times as necessary in order to brix the noncarbonated water valve. After the water valve has been brixed, either enter another program mode or exit the programming modes, which will save programming mode changes.

Syrup Calibration Mode

Once in program mode (4), the control board LED displays (4). Press any touchpad selection area and the associated syrup valve circuit will dispense for three seconds in order to brix the syrup valve circuit. The procedure can be repeated as many times as necessary in order to brix all syrup valve circuits. After all syrup valve circuits have been brixed, either enter another program mode or exit the programming modes, which will save programming mode changes.

Touchpad Configuration Mode

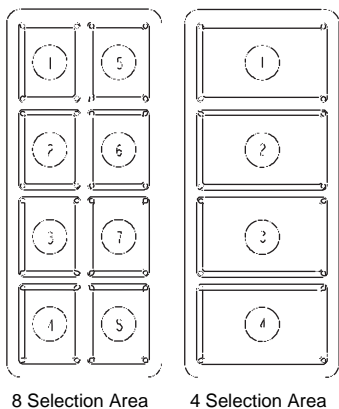

Once in program mode (5), the control board LED displays (5). Press the first and last touchpad selection areas on both touchpads. The touchpad LED lights sequence through all the touchpad selection areas indicating the touchpad has been configured. After configuring both touchpads, either enter another program mode or exit the programming modes, which will save programming mode changes.

Touchpad LED Light Sequencing Mode (8 Selection Area Touchpad)

Once in program mode (6), the control board LED displays (6). Press the first touchpad selection areas on either touchpad for clockwise LED light sequencing. The touchpad LED lights sequence clockwise through all the touchpad selection areas indicating the touchpad has been configured for clockwise LED light sequencing. Or press the second touchpad selection areas on either touchpad for counterclockwise LED light sequencing. The touchpad LED lights sequence counterclockwise through all the touchpad selection areas indicating the touchpad has been configured for counterclockwise LED light sequencing. Or press the third touchpad selection area on either touchpad to turn off LED light sequencing. The third touchpad area LED lights illuminate for 3 seconds then turn off indicating the

touchpad has been configured for LED light sequencing off mode. After configuring the LED light sequencing for touchpads, either enter another program mode or exit the programming modes, which will save programming mode changes.

Touchpad LED Light Sequencing Mode (4 Selection Area Touchpad)

Once in program mode (6), the control board LED displays (6). Press the first touchpad selection areas on either touchpad for upward LED light sequencing. The touchpad LED lights sequence upward through all the touchpad selection areas indicating the touchpad has been configured for upward LED light sequencing. Or press the second touchpad selection areas on either touchpad for downward LED light sequencing. The touchpad LED lights sequence downward through all the touchpad selection areas indicating the touchpad has been configured for downward LED light sequencing. Or press the third touchpad selection area on either touchpad to turn off LED light sequencing. The third touchpad area LED lights illuminate for 3 seconds then turn off indicating the touchpad has been configured for LED light sequencing off mode. After configuring the LED light sequencing for touchpads, either enter another program mode or exit the programming modes, which will save programming mode changes.

Adjustments

QUICKDRAW ICE PORTION ADJUSTMENTS

The Quickdraw ice dispensing system has adjustable ice portion sizes. Follow the directions below to set the ice portion size. Each portion size must be checked according to customer specification at the time of installation.

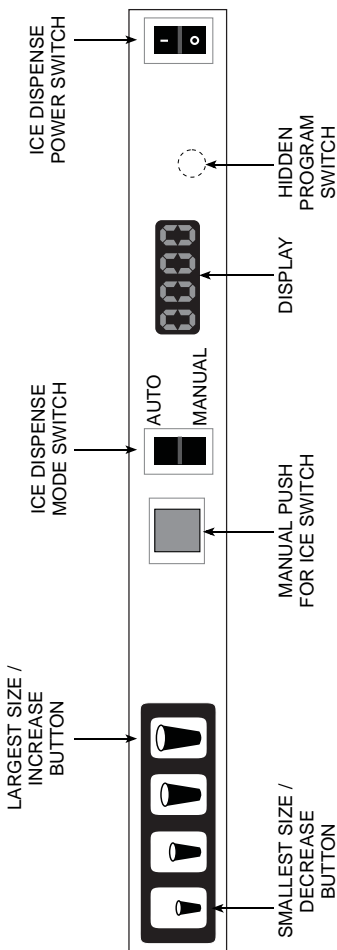

1. To set the ice portion sizes, press the program switch 1 time in 3 seconds. The display will read "0001".
2. Press the ice portion size that is to be adjusted. Once the portion size that is to be adjusted is pressed, the display will show the present pulse setting for that size.
3. To increase the portion size, press the largest size button. To decrease the portion size, press the smallest size button.

NOTE: The pulse count will increase, or decrease, by 1 with each press of the smallest or largest size buttons.

4. Press the program button 1 time to exit program mode and save settings.
5. Repeat steps 1 through 4 for each cup size as necessary.

NOTE: For Data Display Mode, and Test Mode instructions please refer to the Quickdraw Portion Control Program flow chart in this manual.

Free movement of the metering wheel is essential for consistent ice portion sizes.



**One Adjustment Screw on Each Side of
QD Assembly**

The Quickdraw assembly is adjustable to assure the wheel will always move freely. The assembly has two adjustment screws that can be adjusted in or out to align where the ice wheel axle goes through the sensor board and the ice chute.

ROCKING CHUTE ICE DELIVERY SWITCH ADJUSTMENT

To properly adjust the switch, first unplug the power cord to the unit then remove the merchandiser. This will give you access to the ice delivery switch located on the left side of the rocking chute.

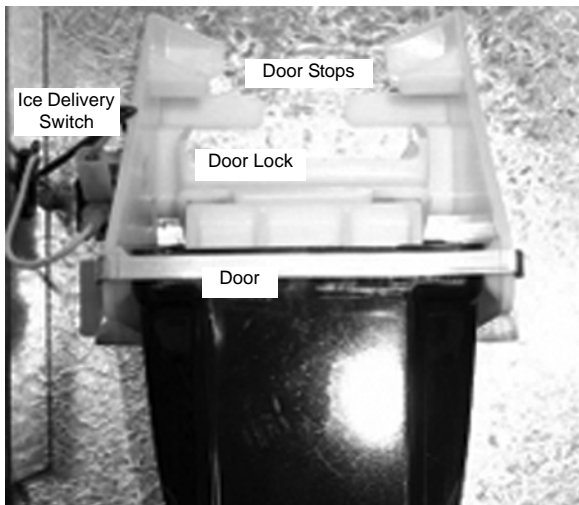

Begin by observing the chute by slowly pushing against the rocking chute. When the ice delivery switch clicks, measure the distance from the door stops on the rocking chute bracket to the door. The distance between the two must be no more than 1/4" (0.64 cm), but no less than 1/16" (0.16 cm).

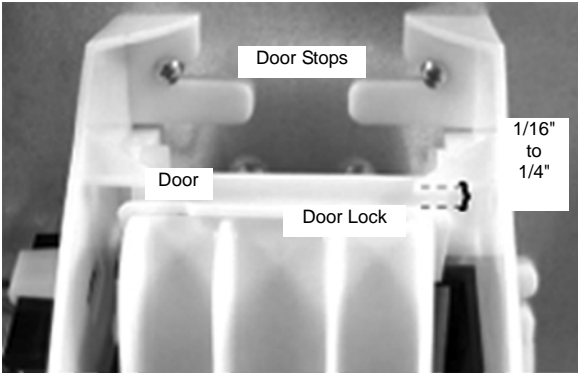

The left side of the rocking chute has a tab that pushes up on the ice delivery switch. To adjust it, use needle nose pliers and bend the arm of the switch up or down in order to change the point where the tab makes contact with the switch arm.

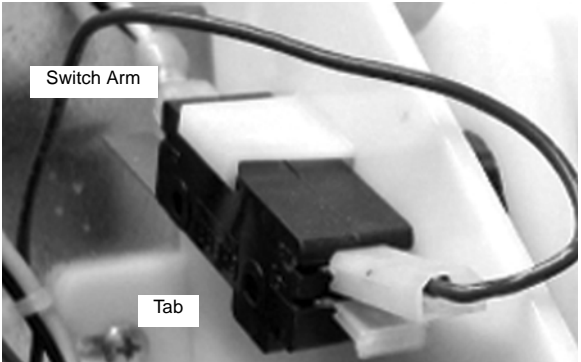

Agitation Timer

The timer is non-adjustable and is set to agitate the ice for 3 seconds every 3.5 hours. Activating the dispenser will reset the timer. After 3.5 hours of non-use, the timer will energize the dispenser motor.

The LED tells the technician in which mode the timer is operating. Rather than a jumper pin, this timer has a female spade connector that must be connected to terminal number 6.

When this jumper is in place, the LED will blink at one-second intervals, this is the run mode.

When the jumper is open, the LED will flash every 0.4 second. This is the test mode and the timer will cycle every 55 seconds in test mode. If the timer is left in test mode, it will automatically reset to run mode.

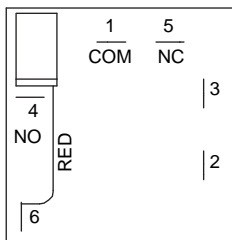

Agitation Timer

Troubleshooting

This Troubleshooting section has been developed to assist you in determining what the probable cause for any particular problem you may experience with your ice/beverage system could be. It then advises of the proper corrective action to be taken to remedy that problem.

Because of the ever present danger from electrical shock, and the existence of high pressure water and gas on the system, it is strongly recommended that only qualified service personnel perform actual repairs.

Checklist

If a problem arises during operation of your dispenser, follow the checklist below. Routine adjustments and maintenance procedures are not covered by the warranty.

Problem	Possible Cause	To Correct
Dispenser will not dispense ice (and NO SOUNDS are heard when machine is activated)	No power	Check electrical connection.
	Loose wire in electrical system	Thoroughly check all wire connections.
	Dispenser overloaded with ice	Remove ice from dispenser until unit will operate.
	Motor not working	Check thermally protected motor. Replace motor or capacitor if necessary.
Dispenser will not dispense ice (motor runs but no ice movement is heard in bin)	No ice in bin	Fill dispenser with ice.
	Door not opening	Check rocking chute mechanism or electric solenoid operation.
	Paddle wheel pin slipped from the paddle wheel	Replace paddle wheel pin.
Excessive clustering or bridging of ice	Loaded ice not broken up. (Caution: Super cooled ice is not covered by the warranty.)	Break ice clusters before manually filling the dispenser. (See ice recommendations.)
	Excessive water spilling from the ice machine	Adjust ice machine to eliminate water spillage.
	Poorly adjusted ice machine	Adjust ice machine to eliminate large waffle shapes.
	Extremely low usage of the dispenser	Lower the ice level in the bin.

Problem	Possible Cause	To Correct
Ice dispenses continuously	Misaligned microswitch	Adjust microswitch.
	Agitation timer set incorrectly	Test agitation timer.
Thumping noise or irregular sound at a particular area of the dispenser	Shaved ice clusters in the bin	Remove clusters, discover why ice is shaving, and then repair.
Dispensing crushed ice or reduced dispensing speed	Water spillage from ice machine into dispenser bin	Adjust ice machine.
	Agitation timer (FRP-250)	Test agitation timer.
	Bridge of ice sheet is too thick	Adjust ice machine.
	Paddle wheel area broken or cracked	Replace paddle wheel area.
	Ice clusters in bin	Break up or remove clusters.
	Door not fully open	Adjust door.
Door will not close	Ice jammed in chute	Adjust bridge in ice machine or, when manually filling, break up clusters.
	Door and/or door lock has come out of place	Replace door and lock into proper position.
Mounting brackets for rocking chute have spread too far apart	Stretched during removal for cleaning or maintenance	Bend parts into shape.

DRINKS

Condition	Investigation	Check	Correction
Warm drinks	Is the compressor running? No	Power switch off or Compressor switch off	Move switch to ON position.
		Ice bank control (CEV)	Check / replace control box.
		Compressor overload	Check / replace overload.
		Start relay	Check / replace relay.
		Compressor	Check / replace compressor.
<p>Note A: It is important to remember that any time the refrigeration system is opened the refrigerant should be recovered, a new drier installed and the proper charge of refrigerant weighed into the refrigeration system.</p>			
No water, syrup or gas dispensing	Is there power to the unit?	No power	Plug in unit or reset breaker.
	Is power coming through the key switch?	Power to control box	Replace fuse or control box.
	Is there power to the key switch?	Key switch OFF	Turn switch ON.
		Key switch defective	Replace key switch.
		No power through the transformer	Reset/replace transformer.
Water only dispensing	No pressure	Regulator(s) out of adjustment	Check/adjust regulator(s).
		Out of CO ₂	Install fresh tank.
		Defective regulator(s)	Check/repair/replace regulator(s).
		CO ₂ line pinched, kinked or obstructed	Check/repair/replace CO ₂ line.
Syrup and CO ₂ only dispensing	Carbonator	No power	Check power supply. Plug in carbonator or reset breaker.
		Water supply	Make sure water is turned ON.
			Replace water filter.
			Check/clean/replace pump strainer.
			Check/clean/repair water check valve.
			Check for frozen water line. Internal Carbonator unit only.
			Check/repair/replace carbonator pump, motor, electrode or liquid level control.
		Defective carbonator	Check/repair/replace carbonator pump, motor, electrode or liquid level control.

Condition	Investigation	Check	Correction
Syrup and plain water only dispensing	No pressure	Out of CO ₂	Install fresh tank.
		HP regulator out of adjustment	Adjust HP regulator to the proper setting.
		Defective HP regulator	Check/repair/replace HP regulator.
		CO ₂ line pinched, kinked or obstructed	Check/repair/replace CO ₂ line.
One valve will not dispense anything	Is there power to the valve?	Broken wire or loose connection	Replace/repair wire or connector.
		Bad microswitch	Replace microswitch.
Beverage dispensed is too sweet	Is the ratio (brix) of the drink correct?	Flow control out of adjustment	Adjust the flow control.
		Insufficient soda flow due to low carbonator pressure	Adjust CO ₂ pressure or change the tank.
		Low CO ₂ pressure due to leaks	Repair CO ₂ leaks.
		Obstruction in the water or soda line	Clean out the lines.
Beverage is not sweet enough	Is the ratio (brix) of the drink correct?	Flow control out of adjustment	Adjust the flow control.
		Soda flow too high	Reset CO ₂ pressure or replace regulator if necessary.
		Obstruction in syrup line	Clean out the syrup line.
Drinks are foaming	Are system pressures correct?	Over carbonation	Check CO ₂ supply. Reset pressure or replace regulator if necessary.
		Dirty lines/valves	Clean/sanitize entire system.

PUMP

Problem	Possible Cause	Correction
Pump motor does not pump	Black and/or red probe shorted	Remove probes and bend straight or replace with new probe(s).
	Problem with motor or motor wiring	Check line voltage first. Check AC voltage across load terminals on Liquid Level Control. If voltage is 120 plus or minus 10%, replace motor or motor wiring.
	Problem with Liquid Level Control Board	Check line voltage first. If AC voltage across load terminals is not 120 plus or minus 10%, replace the Liquid Level Control Board.
	Water pressure from water source is not high enough	Verify water pressure leading into pump inlet is 40 psi minimum with pump running.
Pump will not run but tank appears to be always full	Common Lead (Green) shorted out to Red wire (High Probe)	Verify Green and Red wires are not touching.
Pump will not run but tank level appears to be below start level	Common Lead (Green) shorted out to Black wire (Low Probe)	Verify Green and Black wires are not touching.
Pump motor does not shut off	Problem with Liquid Level Control Board	Short the "H & L" terminals on the Liquid Level Control Board. If motor does not shut off, replace Liquid Level Control Board.
	Probe Harness Connection may be open	Verify connections are good or replace the wiring harness.
	Water may not be reaching top probe in carb tank	Verify tank is not filled with CO ₂ or air by pulling relief valve up and letting air escape until water begins coming out.
	High Lead (Red) open or not connected	Verify Red lead wire is connected from tank to unit.
	Common lead (Green) open or not connected	Verify Green lead wire is connected from tank to unit.
Pump motor intermittent	Problem with probe or probe harness	Check motor and motor wires by removing red and black wires from the Liquid Level Control Board. If okay, short "H & L" terminal on Liquid Level Control Board. If motor stays off, verify probes and bend straight or replace. Verify with meter.
	Problem with motor or motor wiring	Measure AC voltage across load terminals on Liquid Level Control Board. If line voltage is 120 plus or minus 10% replace motor or motor wiring.
Pump motor intermittent	Problem with Liquid Level Control Board	Check line voltage first. If AC voltage across load terminals on Liquid Level Control Board is not 120 plus or minus 10%, replace the Liquid Level Control board.

Problem	Possible Cause	Correction
Pump motor starts and stops, short cycles, as soon as water level drops below Red (High) probe	Black (Low) Lead wire is open or disconnected	Verify connections and continuity of black wire from Liquid Level Control Board to Probes on Carb Tank.
Pump motor starts and stops, short cycles, as soon as water level drops below Black (Low) probe	Red and Black Leads are switched with each other	Verify Red Lead is going to Red probe and Black Lead is going to Black probe.
Pump short cycles from below high probe to just above high probe - Low probe has no effect	Red and Green Leads are switched with each other	Verify Red Lead is going to Red Probe and Green Lead is going to Ground Screw on tank
	Black and Green Leads are switched with each other	Verify Black Lead is going to Black Probe and Green Lead is going to Ground Screw on tank.

BLADE TOWER

Condition	Investigation	Check	Correction
Water Only Dispensing	No Pressure	BNB Fittings Clogged Tank Fittings Clogged No Power	Clean and Sanitize. Clean and Sanitize. Check Power Supply.
Syrup and CO ₂ only Dispensing	Carbonator	Check Liquid Level Control Board For Clogging	Replace Control.
One Valve will not dispense anything	Pre-Mix Valve (CMBecker) Post-Mix Valve (Flomatic 424)	For Mechanical For Clogging For Mechanical	Clean and Sanitize. Replace if Necessary. Clean and Sanitize.
Beverage Dispense is too sweet or Drinks are Foaming	Are system pressures correct	Syrup Push Pressure	Replace parts or entire valve if necessary.
Drink Stratification too great	Visually verify Soda, Water and Syrup flowing at the same time in mixer block, when initially dispensing	Check Valves in Water and Product Lines. If soda water check valve is bad, Syrup will overcome soda water when first dispensing product. If syrup check valve is bad, soda water will overcome syrup flow when first dispensing product.	Adjust to 30-40 PSI per Tower Manual. Lower equals less foaming. Too low will limit flow volume. Replace check valve(s).

FLEXTOWER

Condition	Investigation	Check	Correction
No power at unit	Electrical circuit	ON/OFF switch	Switch to ON position/replace defective switch.
		Plugged into power source	Plug in power cord.
		Circuit breaker tripped	Determine source of overload.
		Power supply inoperative	Replace power supply.
		24 volt connector from power source to control board	Check connection/connector.
		Control board inoperative	Check/replace control board.
Board/bracket lights inoperative	Light modules	Inoperative light modules	Replace modules.
	Control board	Control board programming	Check and program/reprogram.
Water only dispensing (one or more flavors)--	Syrup circuit	Syrup supply depleted	Replenish syrup supply.
		Syrup pressure too low	Adjust syrup pressure to 40 PSI (2.75 BAR).
		B-I-B connector off	Reattach B-I-B connector.
		B-I-B connector plugged	Clean B-I-B connector.
		Syrup line restricted	Check line from B-I-B pump to MFT-16.
		Syrup outlet plugged at valve	Clean syrup outlet.
		Syrup port plugged at injection shroud	Clean port.
		Outlet syrup line off valve	Replace syrup line.
		Syrup solenoid inoperative	Check power to solenoid. Check/replace solenoid. Check connection to control board.
		Control board inoperative	Check/replace control board.

Condition	Investigation	Check	Correction
Syrup only dispensing	Water circuit	No water pressure	Check source water supply.
		Water pressure too low	Have location check plumbing and/or install water booster unit.
		Water line restricted	Check water line from water source.
		Water lines off water pump	Reattach water lines.
		Water lines off heat exchanger	Reattach water lines.
		Water lines off tee connection in unit	Reattach water lines.
		Water valve solenoid inoperative	Check power to solenoid. Check/replace solenoid. Check connection to control board. Check/replace control board.
Noisy syrup/water valve solenoid	Syrup/water valves	Defective solenoid	Replace solenoid.
Finished drink taste too sweet/not sweet enough	Finished drink brix incorrect	Check brix ratio as specified by syrup manufacturer	Brix finished drink.
Syrup/water leaks	Syrup and water circuits	Check water/syrup connections and components	Tighten connections. Replace leaking components.

FLAVOR MAGIC & FRP-250 FLAVOR SHOTS

Problem	Possible Cause	Corrective Action
Flavor shot syrup does not dispense when flavor button is pressed	Syrup supply depleted	Replace syrup.
	CO ₂ supply depleted	Replace CO ₂ .
	B-I-B disconnect loose or packed with dried syrup residue	Tighten and/ or clean B-I-B disconnect.
	CO ₂ Regulator set to low	Check CO ₂ regulator for proper setting — 30 PSI (1 Bar) or according to line run.
	Kinked CO ₂ or syrup line	Check lines for kinks.
	B-I-B pump inoperative	Check pumps, replace if needed.
	Valve solenoid inoperative	Check wiring to valve, replace solenoid.
	Vinyl tubing off at nozzle or at solenoid	Reconnect tubing.
	Vinyl tubing plugged with syrup at nozzle or at solenoid	Clean tubing and nozzle.
	Board not in dispense mode	Place control board into dispense mode "0".
No power to control board	Disconnected or loose wires	Check connector to transformer and corresponding control board.
	No power to transformer	Check power supply at transformer — 24 VAC.
Flavor syrup does not shut off	Check for stuck solenoid	Replace solenoid if it continues to stick.

SELECTABLE ICE

Problem	Possible Cause	To Correct
DISPENSER DOES NOT DISPENSE CRUSHED ICE Nothing is heard	No power	Check power source and power cord.
	Loose wire in electrical system	Check wiring.
	Dispense switch faulty	Replace switch.
	Crusher Motor Faulty	Replace Motor/Gear Box.
	Dispenser Safety Switch Open	Assure Merchandiser is installed correctly with the safety switch in the closed position.
Crusher motor hums but does not turn	Blades obstructed	Check for obstructions in ice crusher housing.
	Motor faulty	Replace motor.
	Faulty start relay/capacitor	Check relay/capacitor and replace if bad.
Crusher dispense door does not open	Door solenoid faulty	Replace solenoid.
	Loose wiring to solenoid	Check wiring.
Gear box on motor	Gear box on motor faulty	Replace Ice Crusher Motor Assembly.
	Crusher Axle broken	Replace Crusher Axle.
Crusher Motor turns but Gear Motor for Paddle wheel/Agitator Bar does not turn	Agitator Gear Motor faulty	Replace Agitator Gear Motor.
	Loose wiring	Check wiring.
	Obstruction in Ice bin stopping motor	Check for obstruction.
Nothing on dispenser works	No power to dispenser	Check power source.
	Dispenser Safety Switch opens	Assure Merchandiser is installed correctly with the safety switch in the closed position.
	Loose wiring	Check wiring.
Difficulty inserting Blade/Hub Assembly into Crusher housing	Stationary Blades not aligned with locating slots at top and bottom of crusher housing	See Disassembly in this manual.
	Rotating Blades not in vertical position	
	Ice in Crusher Housing	
Crushed Ice dispenses continuously, or by itself	Ice Dispense Switch Faulty	Adjust bridge in ice machine or, when manually filling, break up clusters.
No flashing lights on keypad, Fluorescent light was on, crusher and whole ice dispenser will not function, transformer breaker blown.	Water shorted out wiring harness on valves only	Clean up water and reset transformer.

MDH-302 AND 402 ICE PIC

Condition	Investigation	Check	Correction
Dispenser does not dispense crushed ice	Nothing is heard	No power to dispenser	Check power source and power cord.
		Loose wiring	Check wiring.
		Dispense switch faulty	Replace switch.
		Crusher Motor faulty	Replace Motor/Gear Box.
		Dispenser Kill Switch open	Ensure Merchandiser is installed correctly and translight is in place, holding switch in the closed position.
	Crusher motor hums but does not turn	Blades obstructed	Check for obstructions in ice crusher housing.
		Motor faulty	Replace Motor.
		Faulty start relay/capacitor	Check relay/capacitor and replace if bad.
	Crusher dispense door does not open	Door solenoid faulty	Replace Solenoid.
		Loose wiring to solenoid	Check wiring.
	Motor turns, but blades do not turn	Gear box on motor Faulty	Replace Ice Crusher Motor/Gear Box.
		Crusher Axle broken	Replace Crusher Axle.
	Crusher Motor turns but Gear Motor for Paddlewheel/Agitator Bar does not turn	Agitator Gear Motor faulty	Replace Agitator Gear Motor.
		Loose wiring	Check wiring.
Obstruction in Ice bin stopping motor		Check for obstruction.	
Nothing on dispenser works	No power to dispenser	Close Dispenser Kill Switch.	
	Dispenser Kill Switch open	Ensure Merchandiser is installed correctly and translight is in place, holding switch in the closed position.	
	Loose wiring	Check wiring.	
Difficulty inserting Blade/Hub Assembly into Crusher housing	Stationary Blades not aligned with locating slots at top and bottom of crusher housing	See "Cleaning the Ice Crusher Assembly" in the Maintenance section of this manual.	
	Rotating Blades not in vertical position		
	Check for ice in Crusher Housing		
Crushed Ice dispenses continuously, or by itself	Ice Dispense Switch Faulty	Replace the Ice dispense switch.	
	Micro switch adjustment	Adjust properly.	

Liquid Level Control

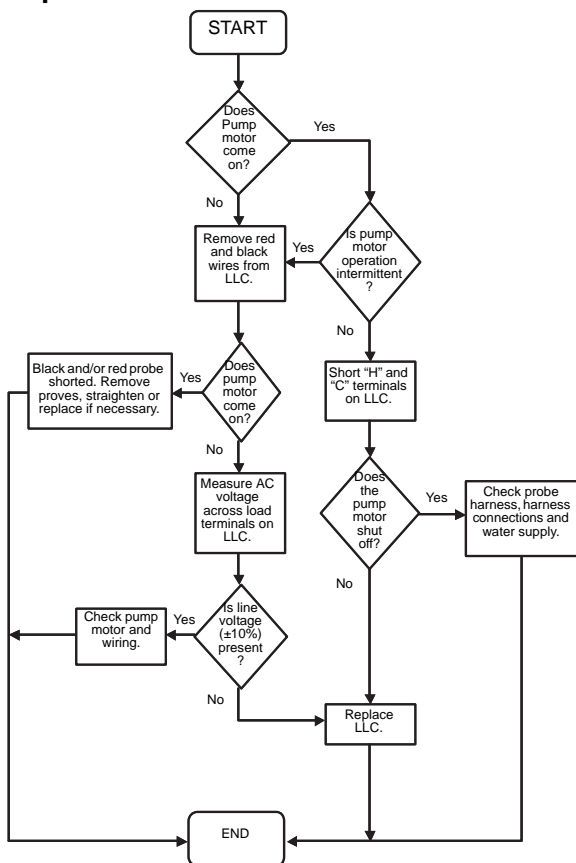

Diagnosing a Defective Carbonator

Go to the dispensing faucet (valve.)

1. Blowing gas is a carbonator problem.
 - A. Unplugged
 - B. Pump
 - C. Motor
 - D. Switching device
 - E. Water off — Noisy pump
 - F. Filters clogged — Noisy pump
2. Syrup mixing w/plain water is a pressure problem.
 - A. CO₂ pressure is too low
 - B. CO₂ cylinder is empty
 - C. Water pressure is too high
 - D. CO₂ inlet check valve is clogged
3. The valve is dispensing a thin trickle of syrup with no water or gas
 - A. Carbonated water is frozen
 - B. Valve is defective

Component Specifications



Warning

All wiring must conform to local, state and national codes.

Electrical Requirements

Refer to Ice Machine Model/Serial Plate for voltage/ amperage specifications.

VOLTAGE

The standard voltage for S/SV/SVI/NGF/FRP Series dispensers is 120VAC-60Hz. A power cord is provided with 120VAC-60Hz models only. S/SV/SVI/NGF Series dispensers use a 1/7 hp gearmotor.

Minimum Circuit Ampacity

The minimum circuit ampacity is used to help select the wire size of the electrical supply. (Minimum circuit ampacity is not the beverage/ice machine's running amp load.) The wire size (or gauge) is also dependent upon location, materials used, length of run, etc., so it must be determined by a qualified electrician.

Minimum Circuit Amperage Chart

Important

Due to continuous improvements, this information is for reference only. Please refer to the dispenser serial number tag to verify electrical data. Serial tag information overrides information listed on this page.

Dispenser	Voltage/Cycle	Minimum Circuit Amps
CEV-30, CEV-40	120/60	8.2
	208-230/60, 220-240/50Hz	
DI-1522, CT-6	120/60	2.4
	220/50	
DI/DIL2323, CT-8	120/60	3.2
	220/50	
Flavor Magic	24VAC, powered by existing valve transformer on dispenser	0.5
FlexTower	120/60	2.5
FRP-250	120/60	3.0
MDH-302, MDH-402	120/60	3.5
MDH-302SCI, MDH-402SCI	120/60	5.4
S-150, S-200, S-250, SV-150, SV-175, SV-200, SV-250, SV-150i, SV-175i, SV-200i, SV-250i, SV-250QD, NGF-250, NGF-250QD	115/60	2.8
	220/50, 220/60, 240/50, 240/60	1.5
	220-240/50	5 (with carb deck)

NOTE: For FlexTower applications — A dedicated 120 VAC, 15 ampere circuit is required to provide power to the power supply's transformer with an output of 24 VAC for the electric valves, 120 VAC, 8 ampere circuit, and to power a cold water recirculation pump. The power supply has a 120 VAC outlet to provide power for the cold water recirculation pump.

Grounding Instructions



Warning

The beverage/ice machine must be grounded in accordance with national and local electrical codes.

This appliance must be grounded. In the event of malfunction or breakdown, grounding provides a path of least resistance for electric current to reduce the risk of electric shock. This appliance is equipped with a cord having an equipment-grounding conductor and a grounding plug. The plug must be plugged into an appropriate outlet that is properly installed and grounded in accordance with all local codes and ordinances.



Warning

Improper connection of the equipment-grounding conductor can result in a risk of electric shock. The conductor with insulation having an outer surface that is green with or without yellow stripes is the equipment grounding conductor. If repair or replacement of the cord or plug is necessary, do not connect the equipment-grounding conductor to a live terminal. Check with a qualified electrician or serviceman if the grounding instructions are not completely understood, or if in doubt as to whether the appliance is properly grounded. Do not modify the plug provided with the appliance — if it will not fit the outlet, have a proper outlet installed by a qualified electrician.

Warning

When using electric appliances, basic precautions must always be followed, including the following:

- a. Read all the instructions before using the appliance.
- b. To reduce the risk of injury, close supervision is necessary when an appliance is used near children.
- c. Do not contact moving parts.
- d. Only use attachments recommended or sold by the manufacturer.
- e. Do not use outdoors.
- f. For a cord-connected appliance, the following shall be included:
 - Do not unplug by pulling on cord. To unplug, grasp the plug, not the cord.
 - Unplug from outlet when not in use and before servicing or cleaning.
 - Do not operate any appliance with a damaged cord or plug, or after the appliance malfunctions or is dropped or damaged in any manner. Contact the nearest authorized service facility for examination, repair, or electrical or mechanical adjustment.
- g. For a permanently connected appliance — Turn the power switch to the off position when the appliance is not in use and before servicing or cleaning.
- h. For an appliance with a replaceable lamp — Always unplug before replacing the lamp. Replace the bulb with the same type.
- i. For a grounded appliance — Connect to a properly grounded outlet only. See Grounding Instructions.

Pump Deck Wiring

The supply cord is equipped with a three prong 5-15P. When a Ground Fault Circuit Interrupter (GFCI) is required by code, a breaker type protector must be used. We do not recommend GFIC outlets as they are known for more intermittent nuisance trips than panel breakers. To ensure both the safety and proper operation of this equipment, be certain that the electrical receptacle is a proper design so as to accept this plug, ensuring that the carbonator assembly is properly grounded.

If the pump deck is to be installed in an area or community whose local codes require permanent wiring, the following procedure must be followed.

1. The three wires (white, black and green) must be fed through the cable connector and brought into the wiring compartment. The cable must be secured into the connector.
2. The green wire from the cable must be connected to the green screw that attaches to the inside panel of the wiring compartment. Be sure to use a ring torque terminal for connecting the wire to the screw.
3. The white wire from the cable must be joined to the N terminal of the liquid level control board by a suitable U.L. listed insulated cable connector.

The black wire from the cable must be joined to the L1 terminal of the liquid level control board by a suitable U.L. listed insulated cable connector.

Water Supply

RECOMMENDED PLUMBING

The plumbing diagram is printed on a white vinyl label, normally located above the inlet tubes for syrup and water. The plumbing diagram label can be accessed by removing the splash panel of the dispenser. The plumbing diagram label explains which inlet coldplate fittings supply which dispenser valves and water manifolds.

The water supply must first be connected to the carbonator pump (not shown) before plumbing to connection "A" shown on plumbing diagram. The carbonator pump deck must be within six feet (1.8 m) of the dispenser for optimum performance. See B-I-B installation diagram for system pressure settings.

NOTE: Valves are read from right to left.

A check valve must be installed in the water supply line 3 feet (0.9 m) from the noncarbonated water connection "PW". Contact factory if not installed.

PRESSURE SPECIFICATIONS

	Min.	Max.
Incoming Water Pressure	40 psi (2.75 bar)	70 psi static (4.83 bar)
Plain Water Pressure to Carb Tank	55 psi (3.79 bar)	65 psi static (4.48 bar)
Ambient Temperature	40°F (4°C)	105°F (41°C)
CO₂ Pressure (Primary)	90 psi (6.21 bar)	100 psi (6.90 bar)
Pre-mix Pressure		
Normal	60 psi* (4.14 bar)	
Diet	40 psi* (2.75 bar)	
B-I-B (Secondary)	75 psi (5.17 bar) or according to line run	
Flavor Shot	30 psi (2.07 bar) or according to line run	
Quickdraw CO₂ Supply	75 psig (5.17 bar)	
Quickdraw Regulator Valve	40 psig (2.75 bar)	50 psig (3.45 bar)
Quickdraw Carbonation		
Cold	75 psi (5.17 bar)	
Ambient	90 psi (6.21 bar)	100 psi (6.90 bar)

* This is the optimal pressure. When the foam is too high, decrease the pressure; when spitting/popping is an issue, increase the pressure.

Important

When installing cold carbonated (Intelli carb) equipment, never put a tee for the plain water connection in the line from the pump deck to the cold plate. Putting a tee in the line will create service problems and bad drink quality.

NOTE: For FlexTower applications, a plain water supply capable of delivering 100 GPH (378.5 liters/hr) with a minimum dynamic water pressure of 40 psi (2.75 bar) and a maximum static water pressure of 80 psi (5.5 bar) is required to provide water for the non carbonated beverages. Water treatment is highly recommended to assure a quality finished beverage.

CAPACITIES

Dispenser	Valves	Ice Storage
CEV-30	6	N/A
CEV-40	8	N/A
CT-6	6	N/A
CT-8	8	N/A
DI-1522	6	65 lbs (29.5 kg)
DI2323	8	77 lbs (34.9 kg)
DIL2323	8	97 lbs (44 kg)
Flavor Magic	3-4 Flavors	N/A
FlexTower	8-16 Flavors	N/A
FRP-250	16 Flavors, 8 Flavor Shots	250 lbs (113 kg)
S/SV-150	6	150 lbs (68 kg)
SV-175	8	175 lbs (79.4 kg)
S/SV-200 (SCI)	8-10	200 lbs (90.7 kg)
S/SV/NGF-250 (SCI/QD)	8-10	250 lbs (113 kg)
MDH-302 (SCI)	10 or 12	300 lbs (136 kg)
MDH-402 (SCI)	16 or 20	400 lbs (181 kg)

Charts

Flavor Magic Logic Matrix

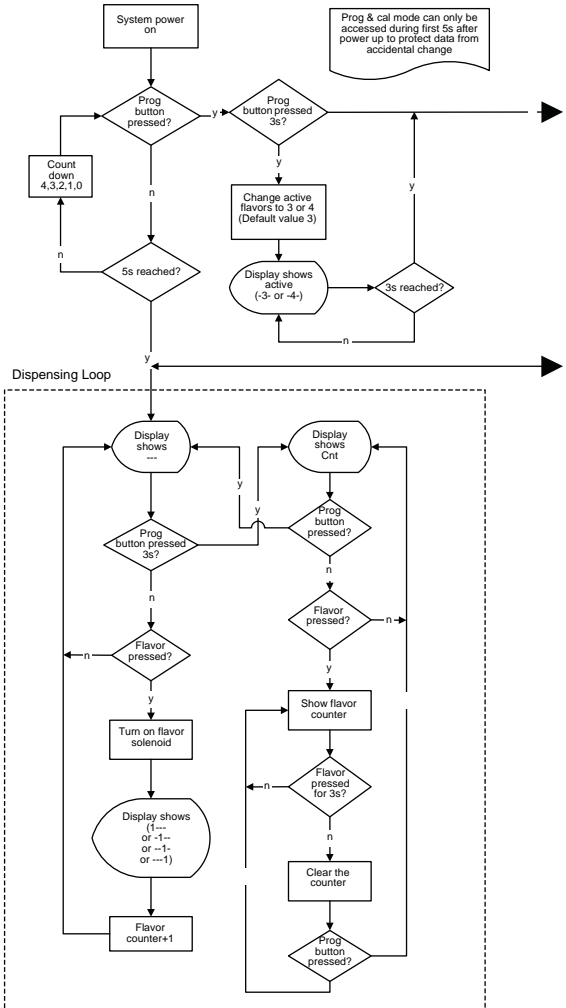

Programming Loop

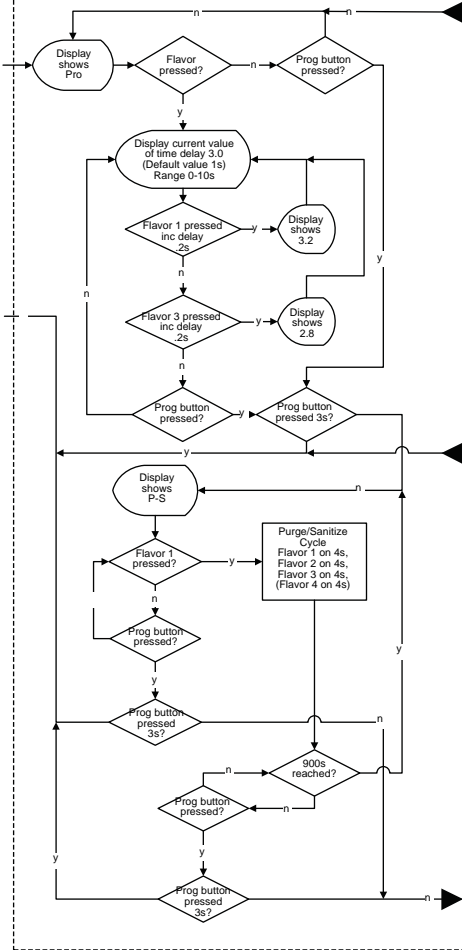

Programming Loop (continued on next page)

Flav'R-Pic (FRP-250) Logic Matrix

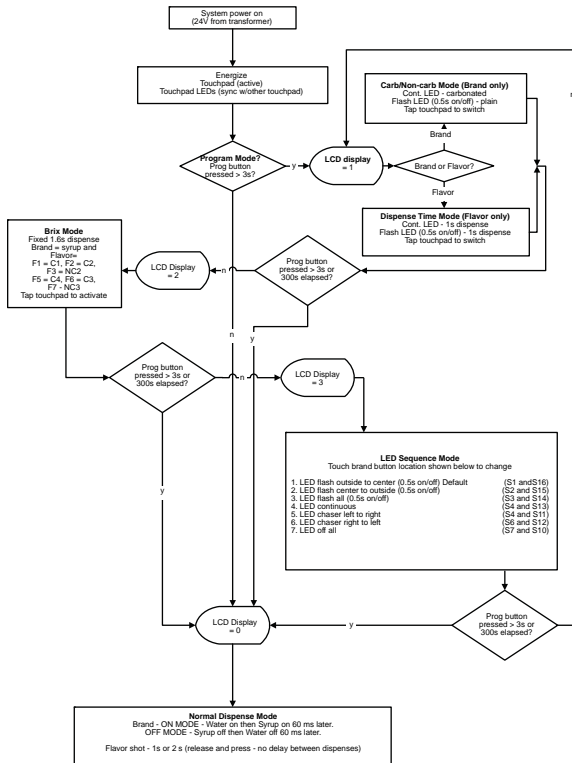

FLAV'R-PIC (FRP-250) CONTROL BOARD, VALVE, TOUCH PAD MATRIX

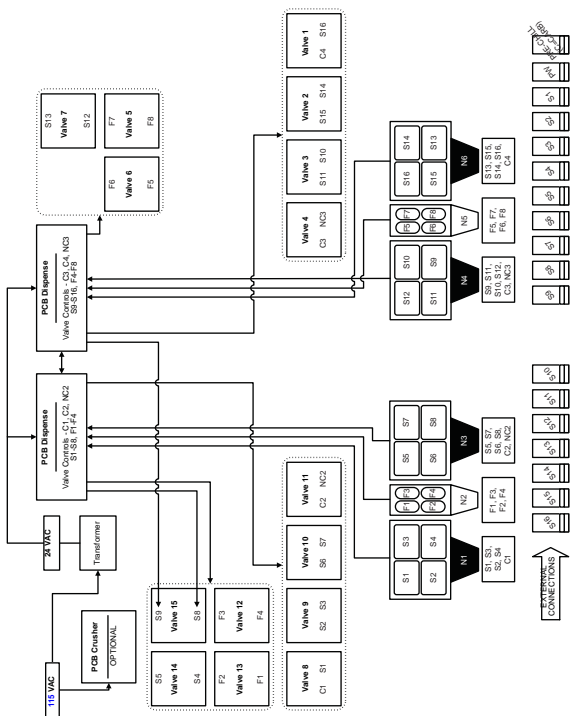

This Page Intentionally Left Blank

Diagrams

Blade Tower Plumbing

SINGLE TOWER

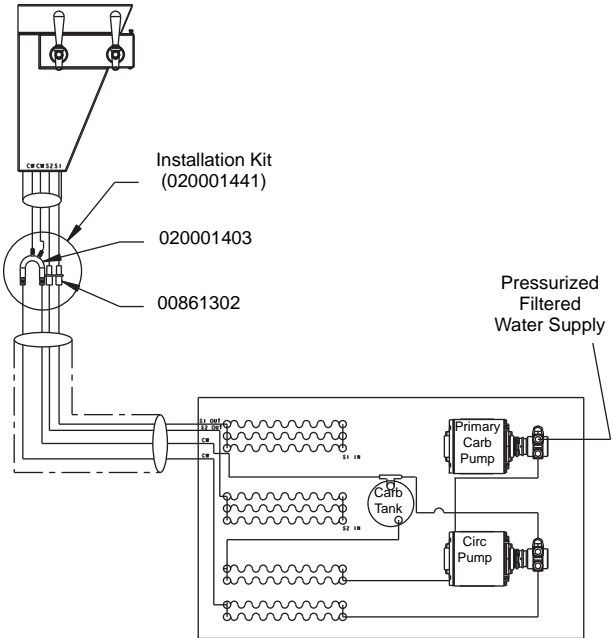

TWO TOWER

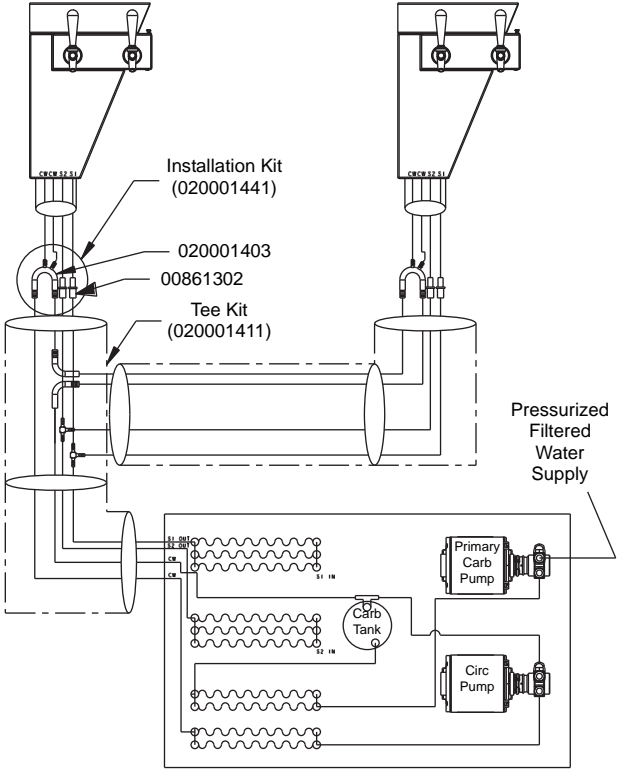

THREE TOWER

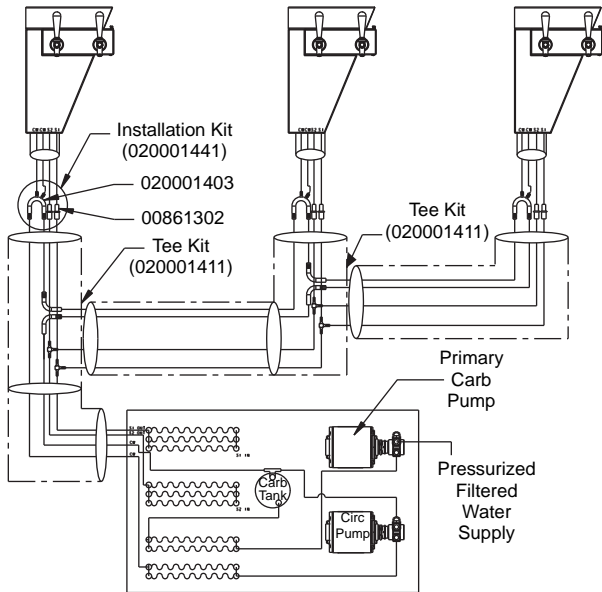

CEV-30i & CEV-30e Plumbing

SERVEND RECOMMENDED PLUMBING
ALL INLETS ARE 3/8" BARBED FITTINGS EXCEPT CO₂ INLET
FOR ASSISTANCE CALL (812)-246-7000
CEV-30i & CEV-30e

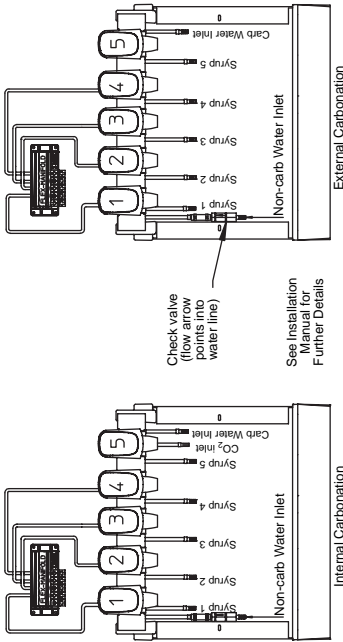

5027794

NOTE:

1. All valves are carbonated water as shipped from factory.
2. Check valve supplied with unit is installed in the non-carbonated water line inlet. The flow direction arrow should point into the stainless steel line.

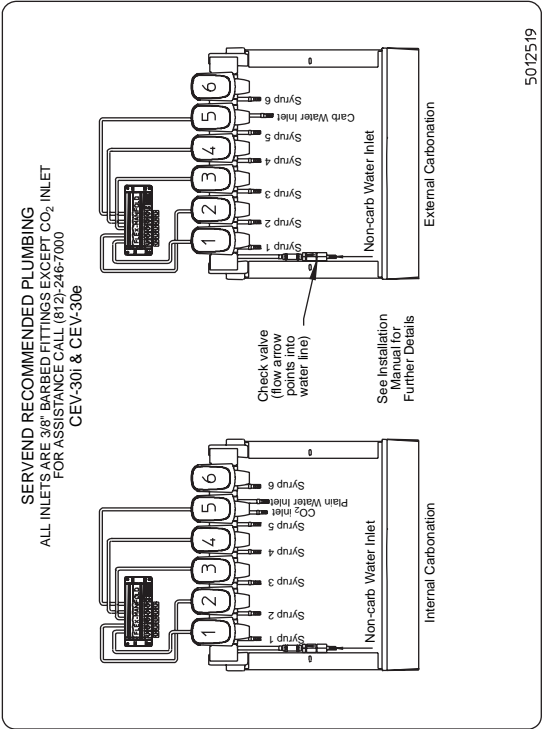

NOTE:

1. All valves are carbonated water as shipped from factory.
2. Check valve supplied with unit is installed in the non-carbonated water line inlet. The flow direction arrow should point into the stainless steel line.

CEV-40i & CEV-40e Plumbing

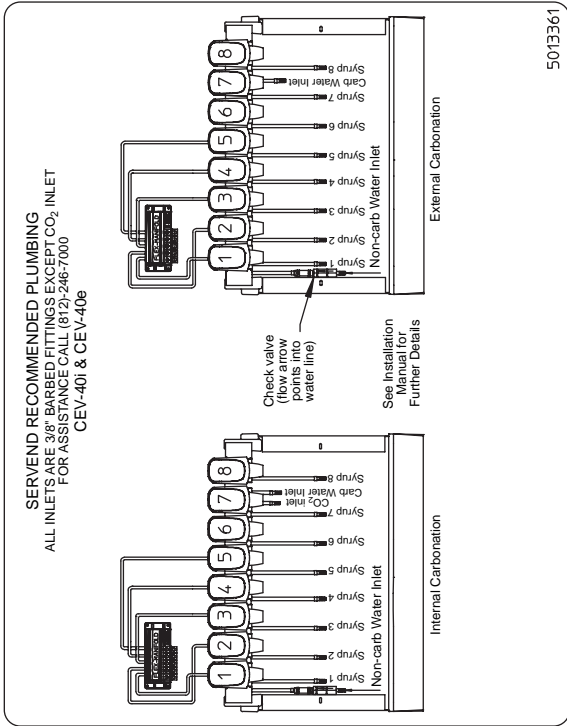

NOTE:

1. All valves are carbonated water as shipped from factory.
2. Check valve supplied with unit is installed in the non-carbonated water line inlet. The flow direction arrow should point into the stainless steel line.

CEV-30j Plumbing

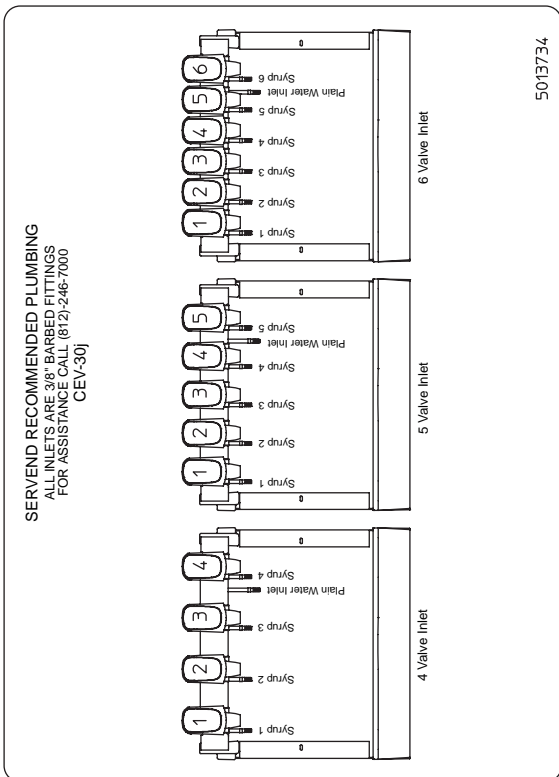

NOTE:

1. Minimum water pressure of 40 psi is needed to attain a 1-1/2 oz/sec flow rate.
2. Minimum water pressure of 55 psi is needed to attain a 2-1/2 oz/sec flow rate.
3. If water pressure varies by ± 20 psi the valve brix will not be maintained.
4. See service manual for further details.

CT-6 Plumbing and Wiring

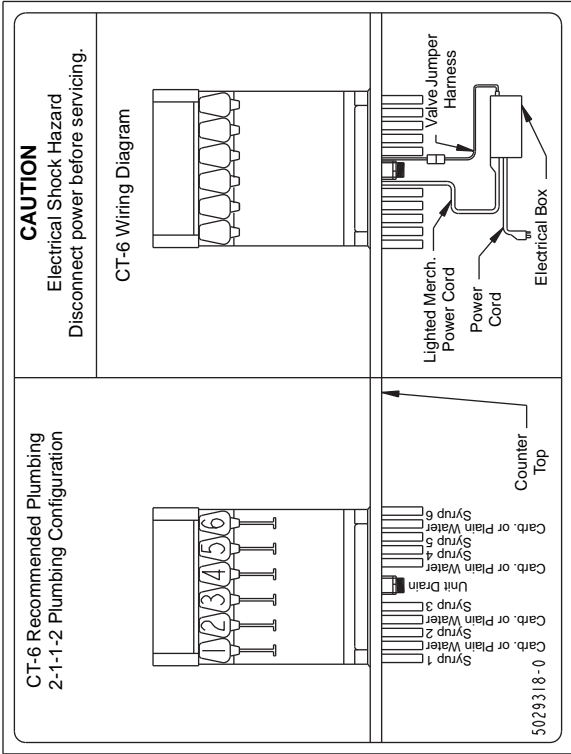

CT-8 Plumbing and Wiring

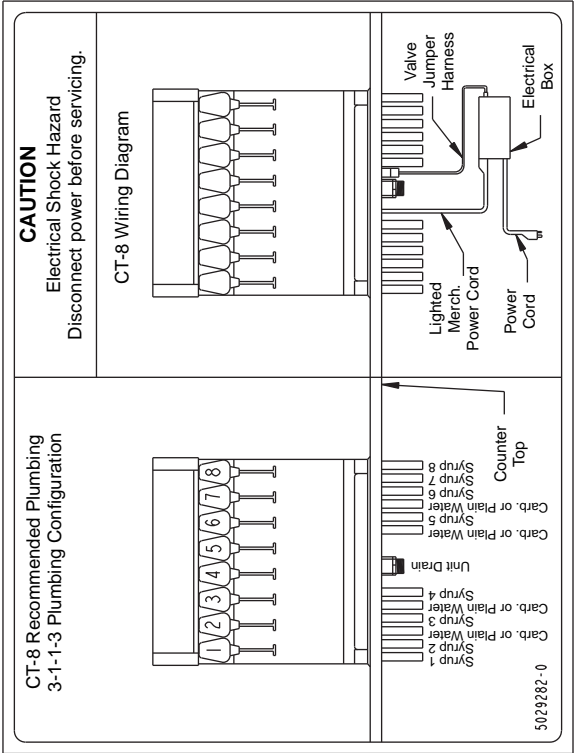

CF-1522 Plumbing

CF-1522 4 Valve Plumbing

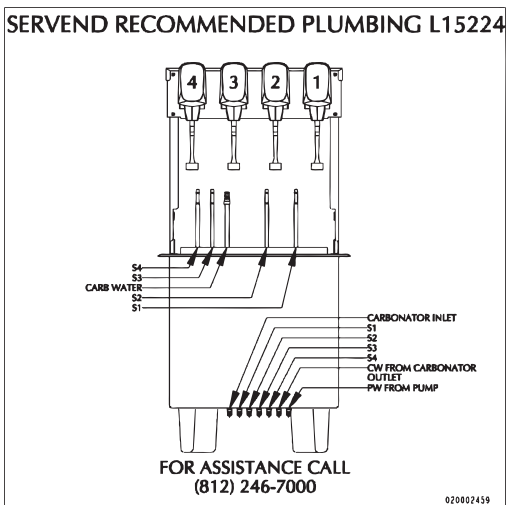

Conversion for non-carbonated flavor

1. De-pressurize system.
2. Remove drain grid, splash panel and drainpan to access insulated lines.
3. Cut carb water line (in tower) to valve to be converted and cap.
4. Disconnect syrup line to valve being converted.
5. Plumb syrup circuit in coldplate to water side of valve (flush syrup line first).
6. Plumb dedicated plain water line from water source to coldplate inlet (syrup circuit converted for chilling water).
7. Run ambient syrup line into drop-in tower to syrup side of valve.
8. Replace drainpan, splash panel and drain grid.
9. Pressurize system and verify system operation.

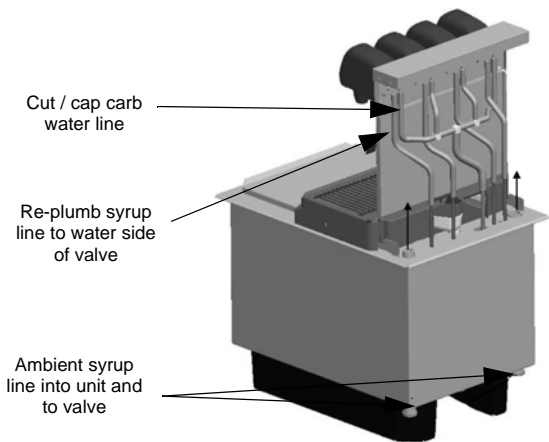

NOTE: Tapping into existing water line too close to the pump deck can result in starving the valve when the carbonator cycles. If a dedicated water line is not possible, tee into the existing water line as close to the source as possible.

DI-1522 Post-mix Plumbing

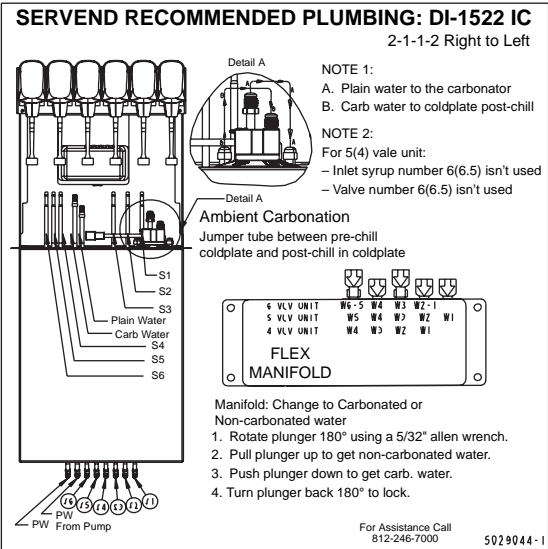

DI-1522 Pre-mix Plumbing

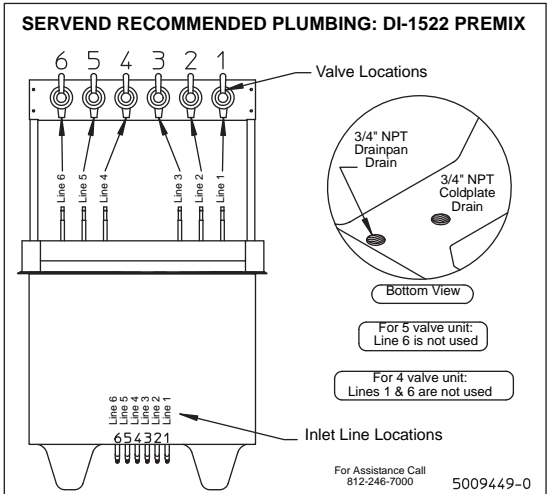

DI/DIL-2323 6 Valve Post-mix Plumbing

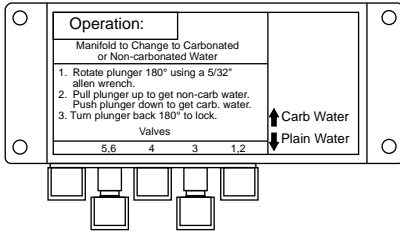
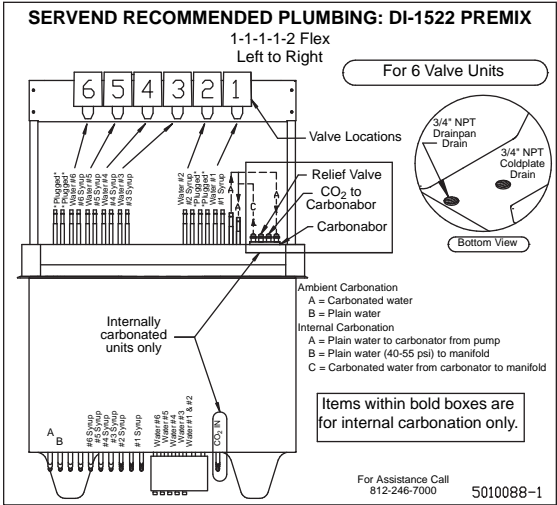

DI/DIL-2323 8 Valve Post-mix Plumbing & Variety Valve

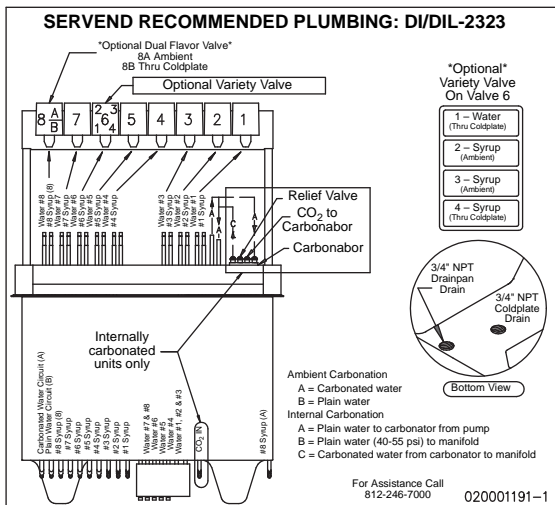

DI/DIL-2323 10 Valve Post-mix Plumbing

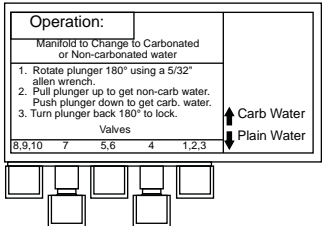
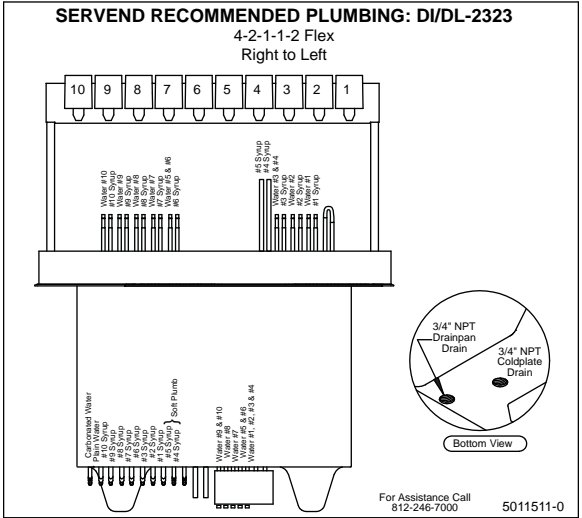

DI/DIL-2323 6 Valve Pre-mix Plumbing

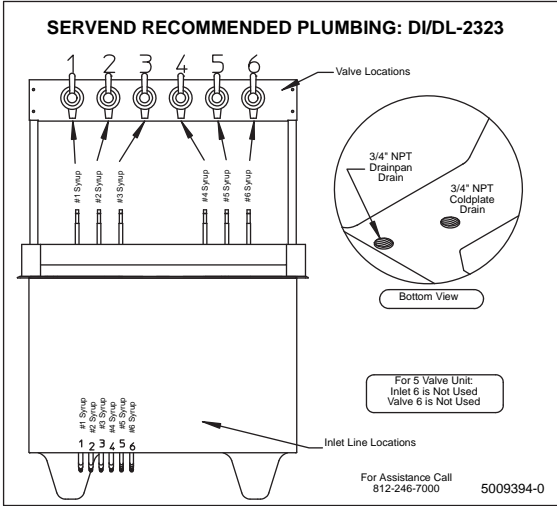

Flavor Magic Plumbing

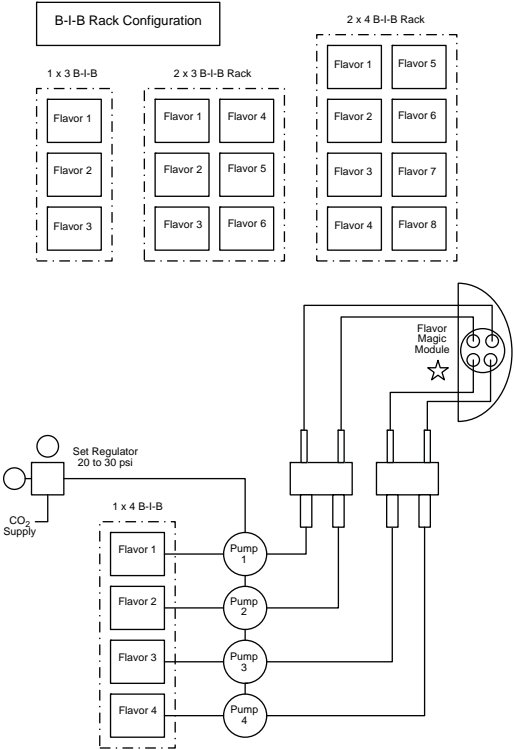

FRP-250 Plumbing Diagram

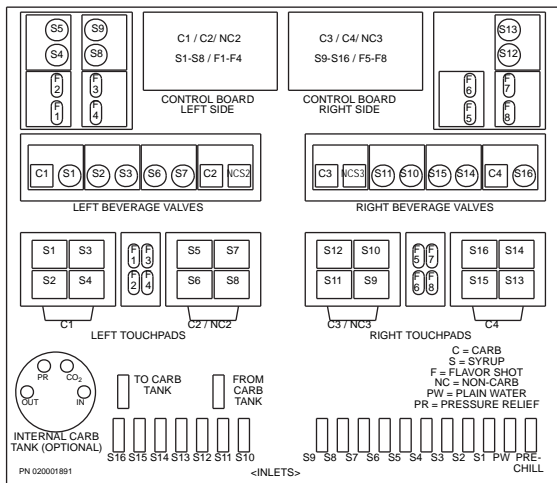

FRP-250 & FRP-250SCI Tubing Layout

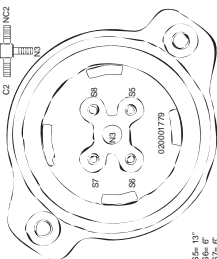

NOZZLE 3
TOP VIEW
FRONT

S5= 13"
S6= 6"
S7= 6"
S8= 13"
NC2= 10"
N3= 10"

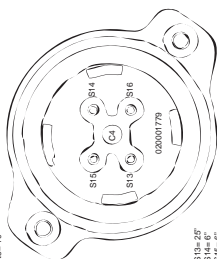

NOZZLE 6
TOP VIEW
FRONT

S13= 25"
S14= 6"
S15= 6"
S16= 6"
C4= 10"

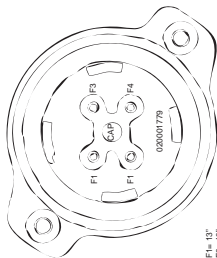

NOZZLE 2
TOP VIEW
FRONT

F1= 13"
F2= 13"
F3= 13"
F4= 13"

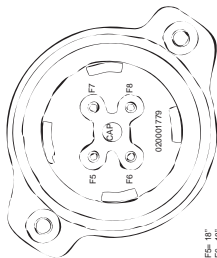

NOZZLE 5
TOP VIEW
FRONT

F5= 18"
F6= 18"
F7= 18"
F8= 18"

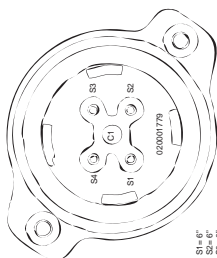

NOZZLE 1
TOP VIEW
FRONT

S1= 6"
S2= 6"
S3= 6"
S4= 13"
C1= 10"

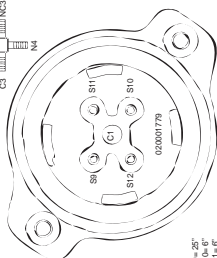

NOZZLE 4
TOP VIEW
FRONT

S9= 25"
S10= 6"
S11= 6"
S12= 25"
C1= 1.5"
NC3= 10"
N4= 10"

FT-8 Plumbing

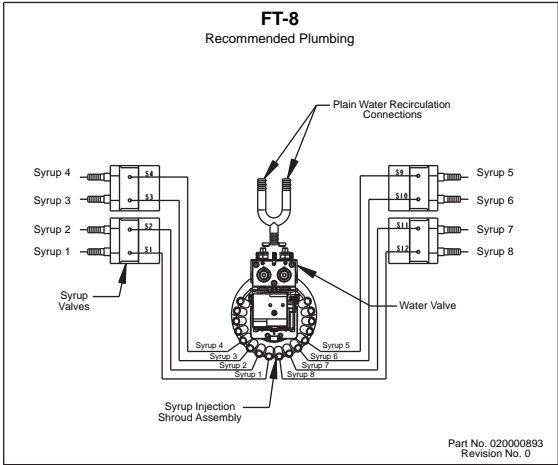

FT-12 Plumbing

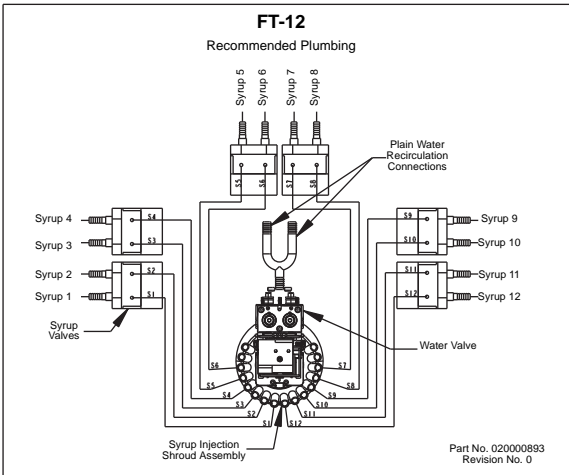

FlexTower Water Recirculation Pump Flow

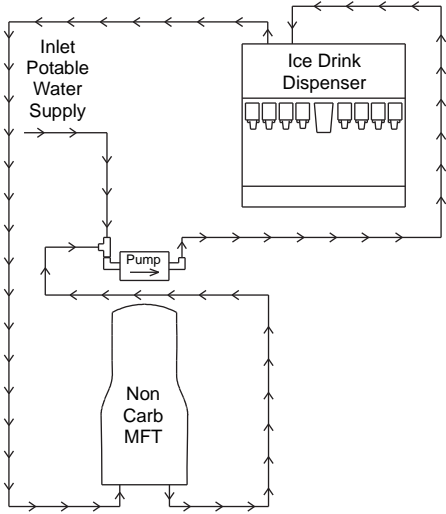

FlexTower Water Chiller Flow

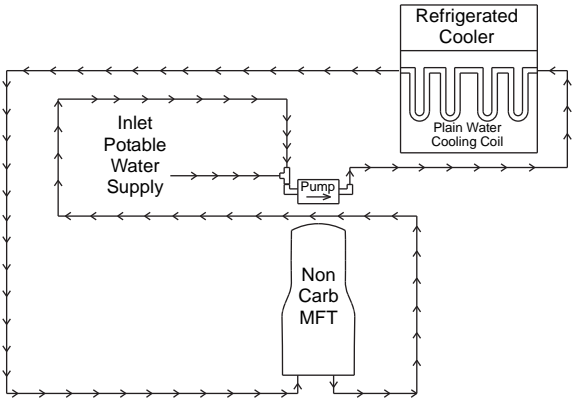

MDH-302 12 Valve Plumbing

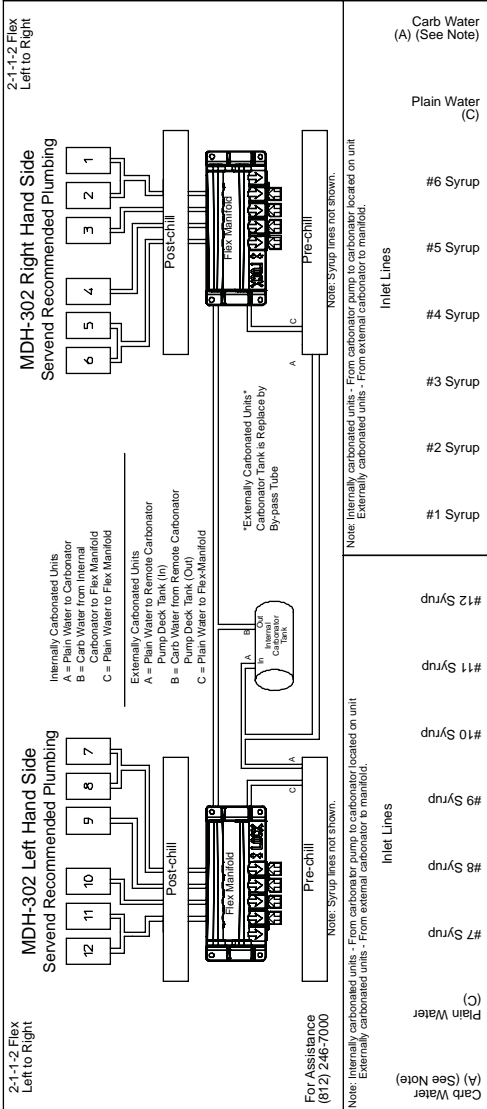

MDH-402 16 Valve Plumbing

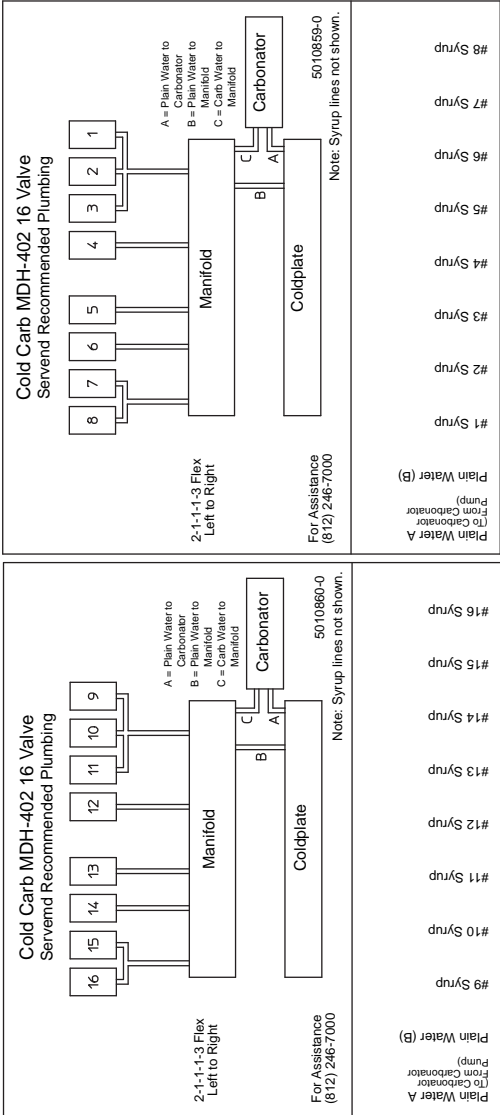

MDH-402 20 Valve Plumbing

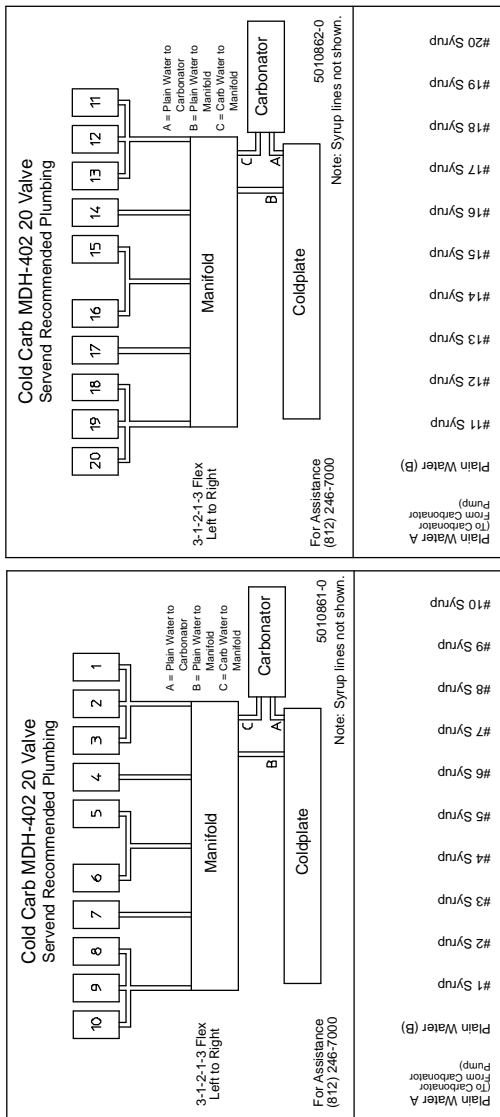

S/SV150 6 Valve Diagram

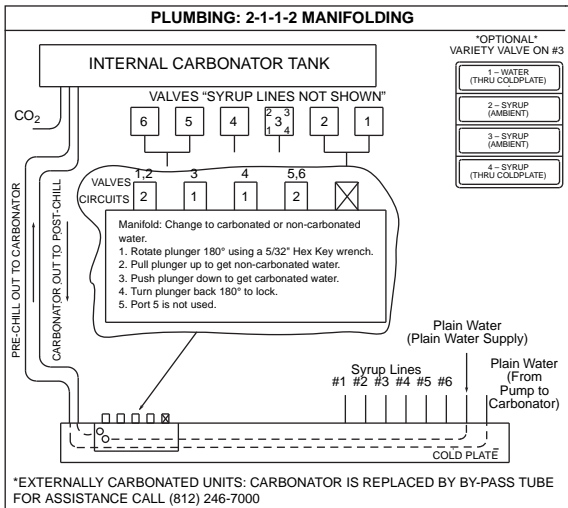

S/SV175 8 Valve Diagram

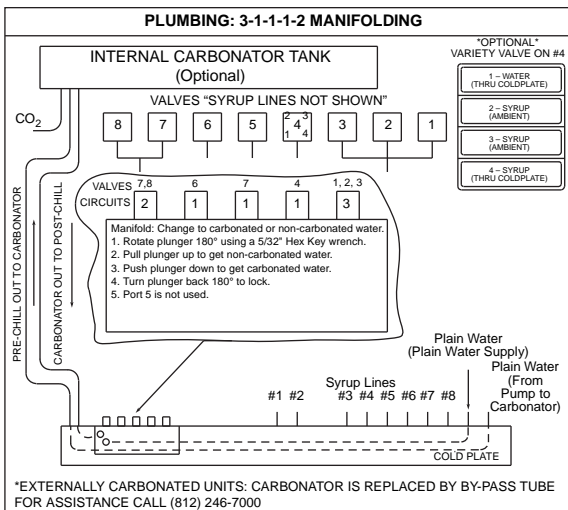

S/SV200/250/SV-250QD 8 Valve Diagram

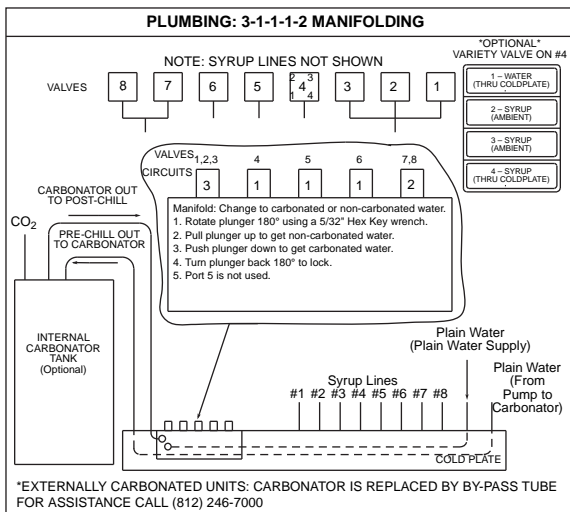

S/SV200/250 10 Valve Diagram

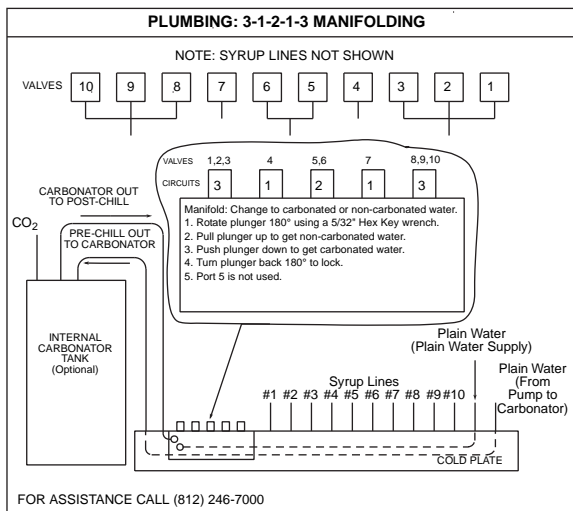

NGF-250 & NGF-250QD 8 Valve Diagram

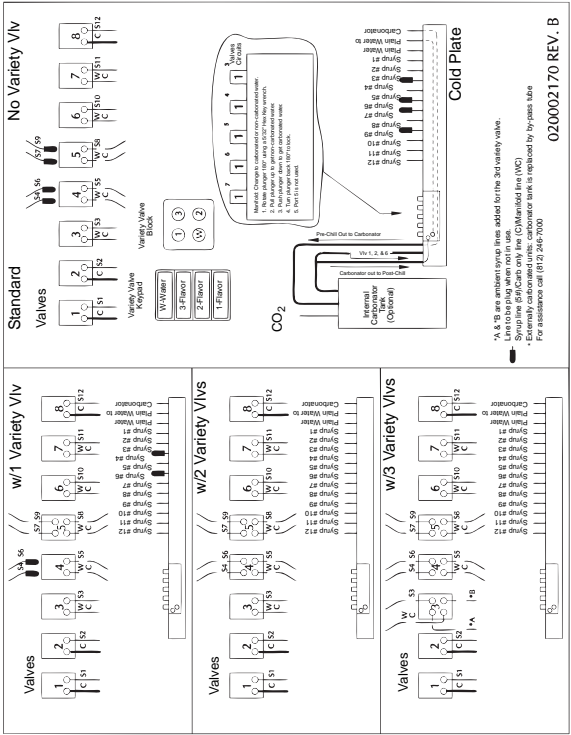

020002170 REV. B

Flex Manifold Diagrams

FLEX MANIFOLD — 6 VALVE

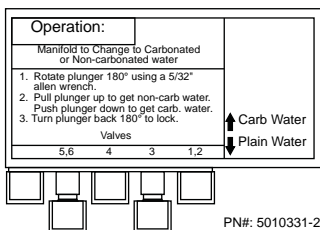

NOTE: 12 valve 302 units use 1 per side.

FLEX MANIFOLD — 8 VALVE

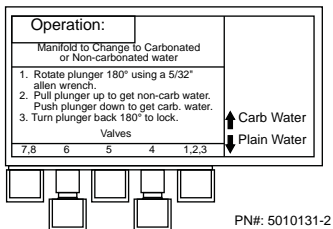

NOTE: 16 valve 402 units use 1 per side.

FLEX MANIFOLD — 10 VALVE

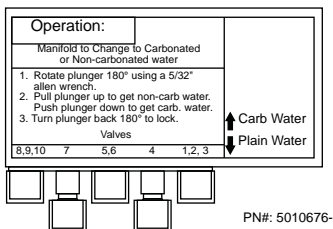

NOTE: 20 valve 402 units use 1 per side.

CEV Wiring

CEV-30i & 40i 115V 60HZ

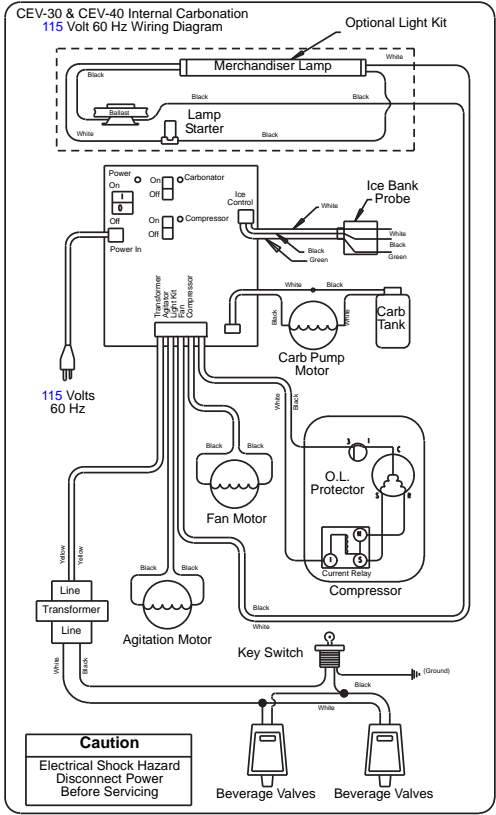

CEV-30e & 40e 115V 60HZ

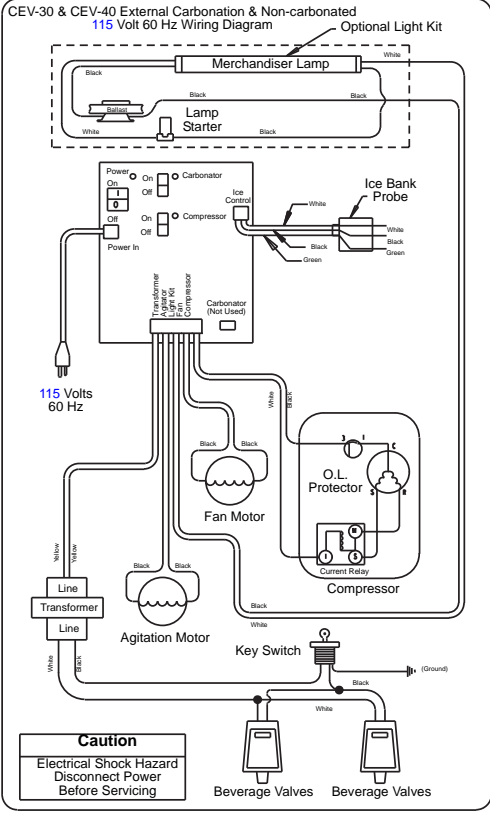

CEV-30i & 40i 208/230V 60HZ

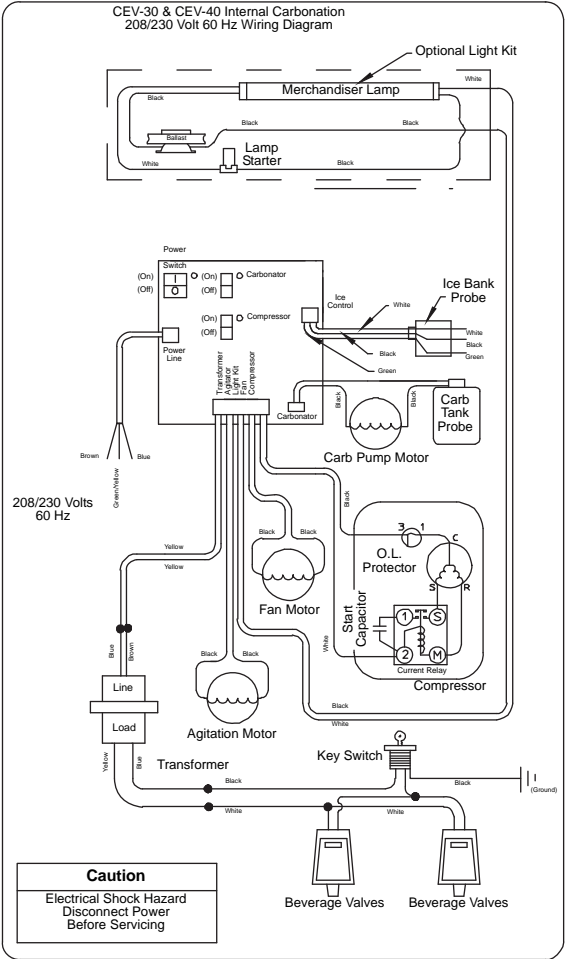

CEV-30e & 40j 208/230V 60HZ

CEV-30 & CEV-40 External Carbonation & Non-carbonation
208/230 Volt 60 Hz Wiring Diagram

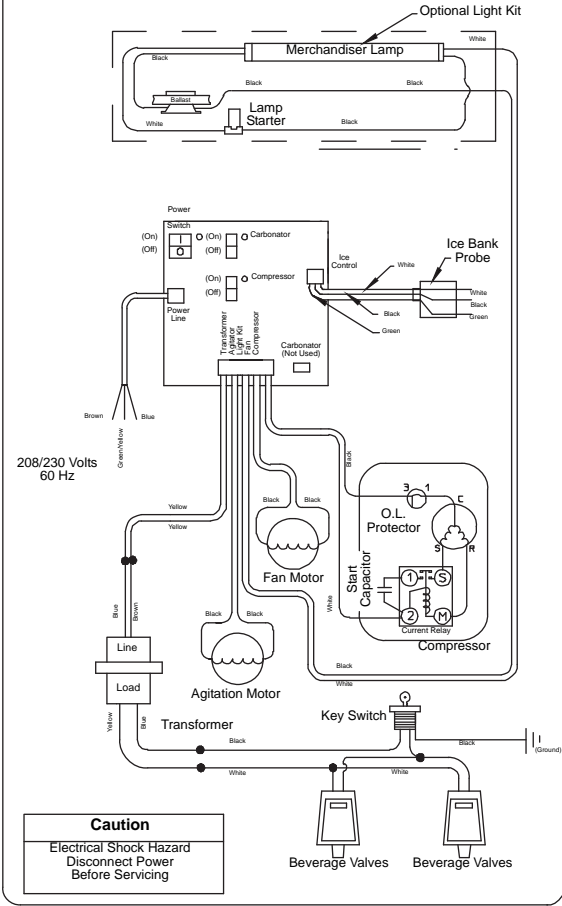

CEV-30i & 40i 220/240V 50HZ

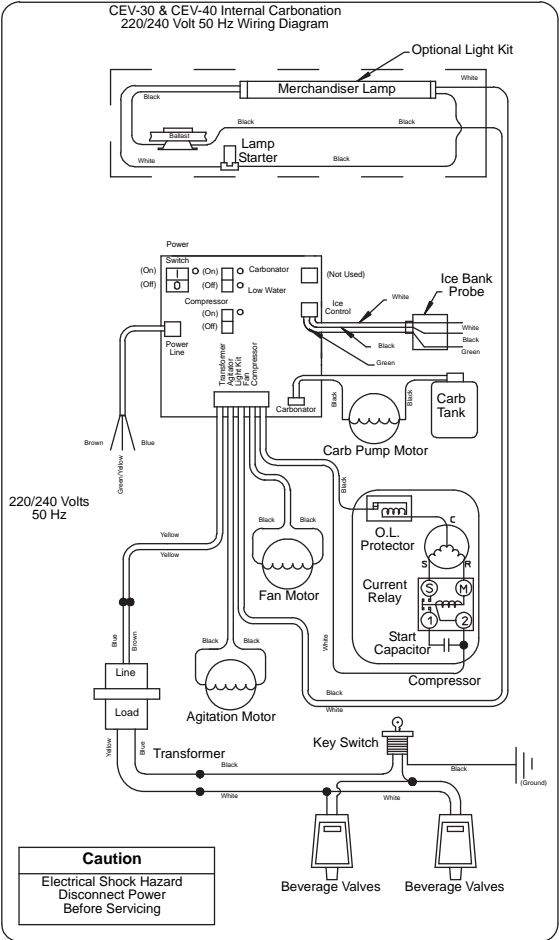

CEV-30e & 30j 220/240V 50HZ

CEV-30 & CEV-40 External Carbonation & Non-carbonation
220/240 Volt 50 Hz Wiring Diagram

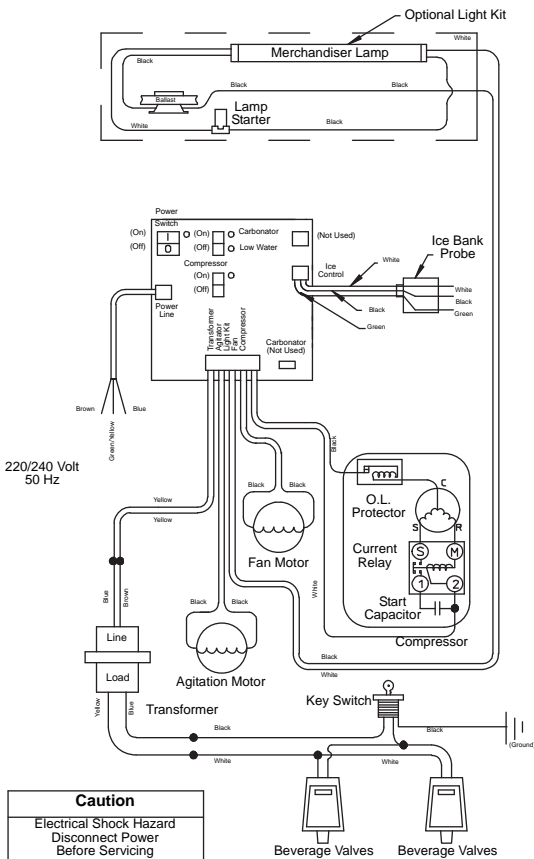

CF Drop-In Series Wiring

CF-1522 115V

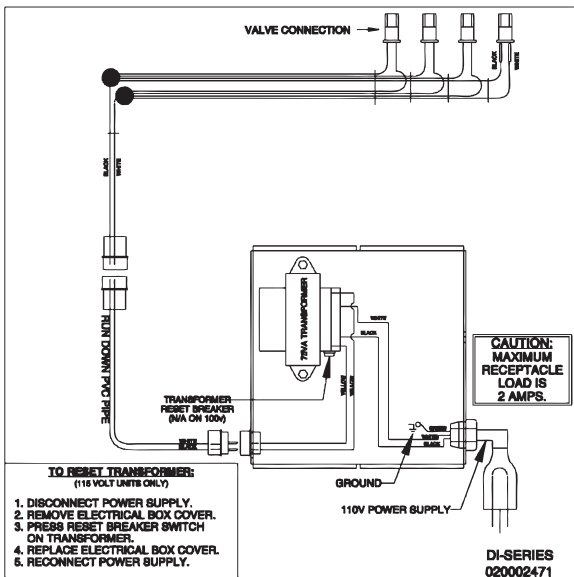

Drop-in Wiring

DI-SERIES IC 110V

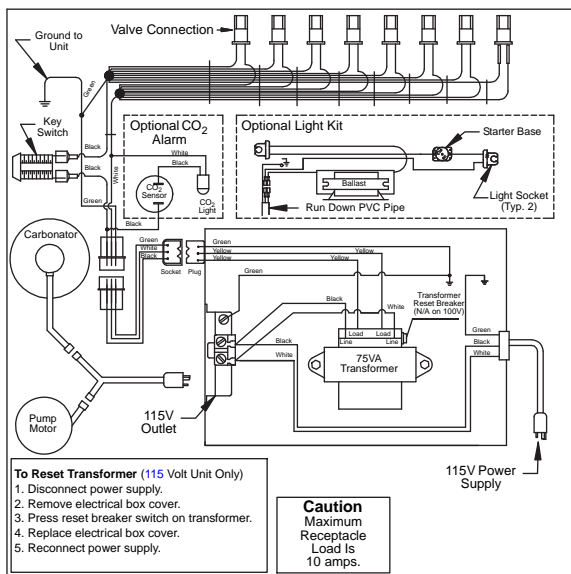

DI-SERIES IC 220-230V

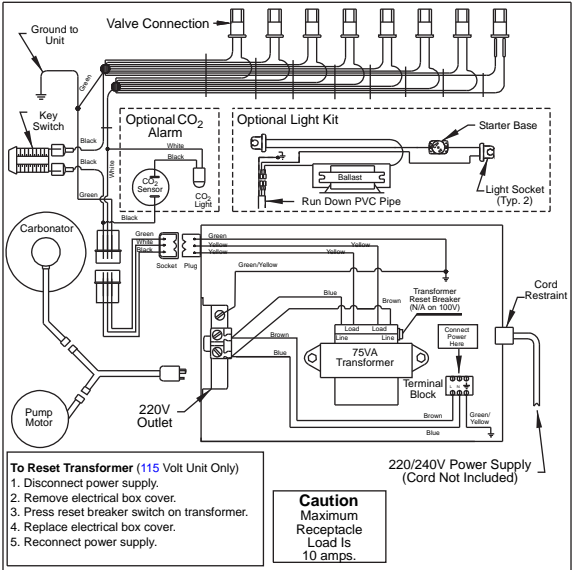

DI-SERIES AMBIENT 110V

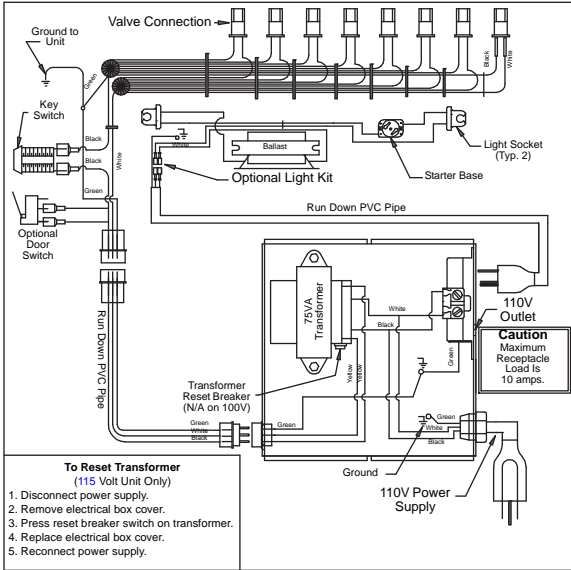

DI-SERIES AMBIENT 220-230V

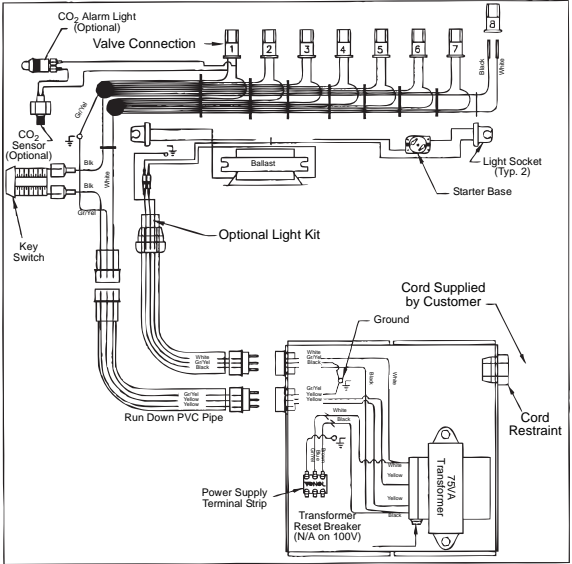

Flavor Magic Wiring

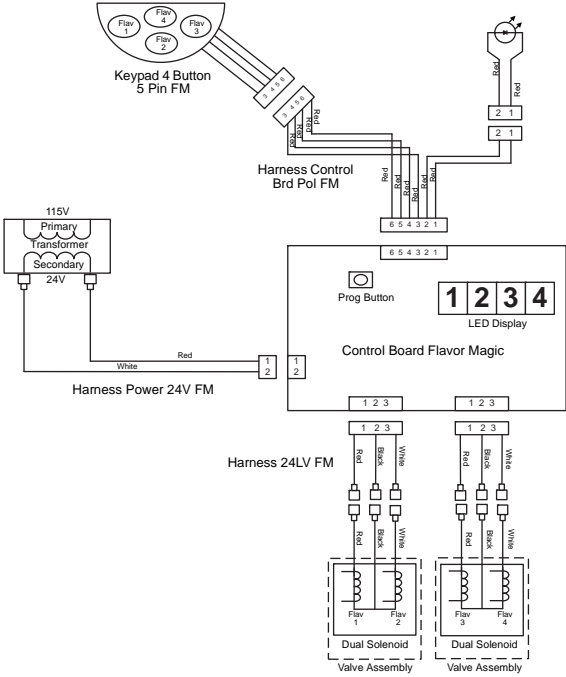

Flav'R-Pic (FRP-250) Wiring

FRP-250 (NON-CRUSHER) WIRING DIAGRAM

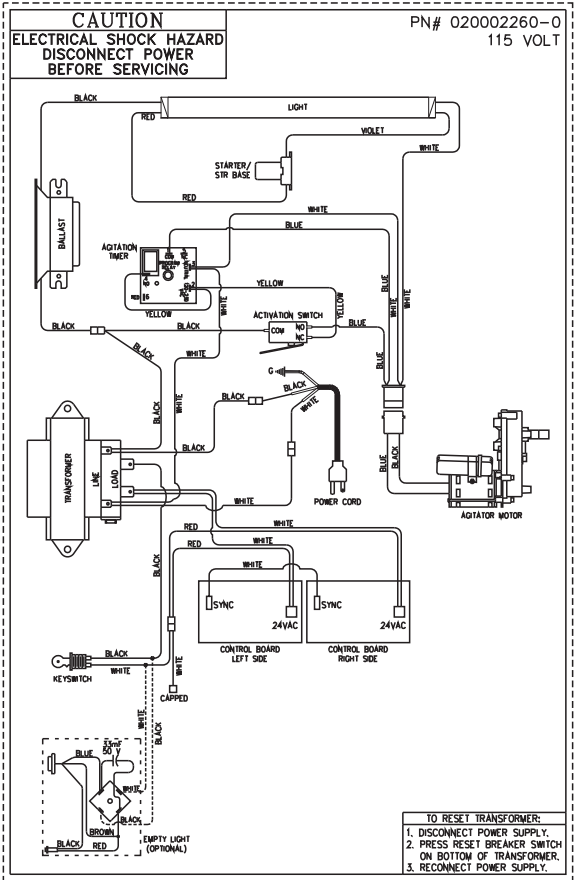

FRP-250SCI WIRING DIAGRAM

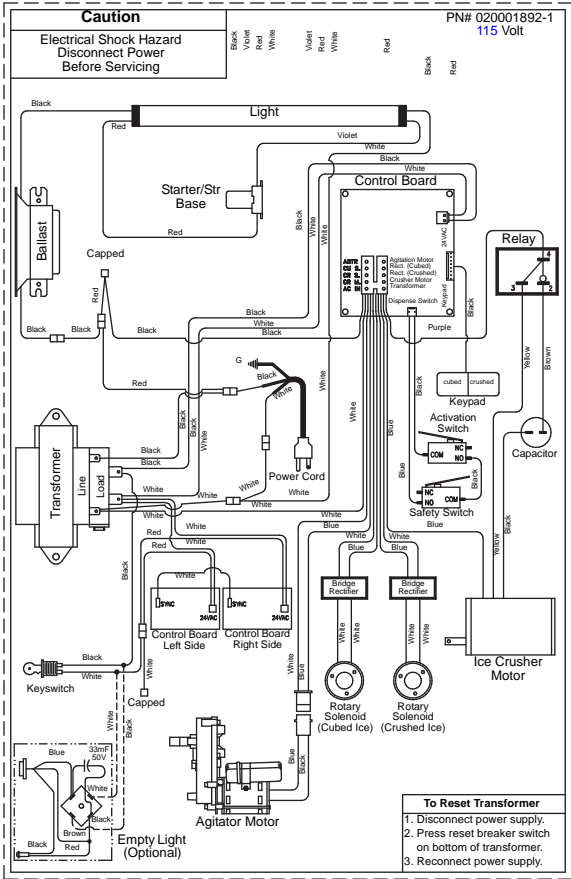

FlexTower Wiring

FT-8 WIRING DIAGRAM

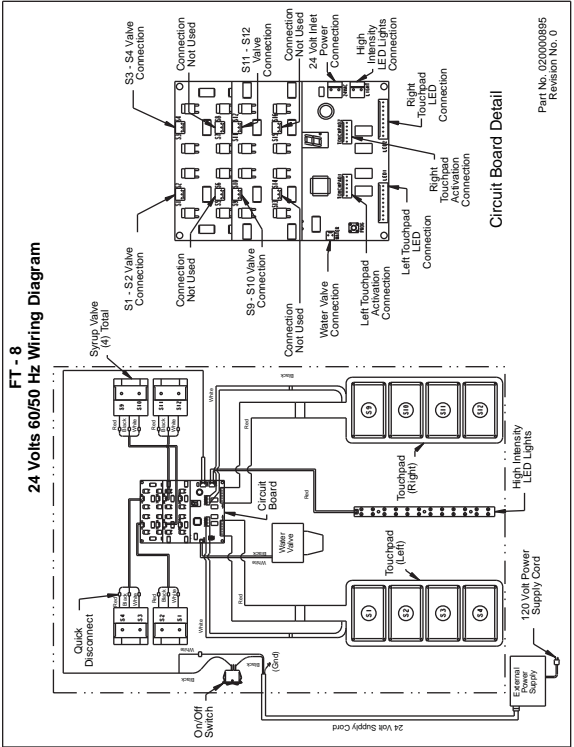

FT-12 WIRING DIAGRAM

FT - 12
24 Volts 60/50 Hz Wiring Diagram

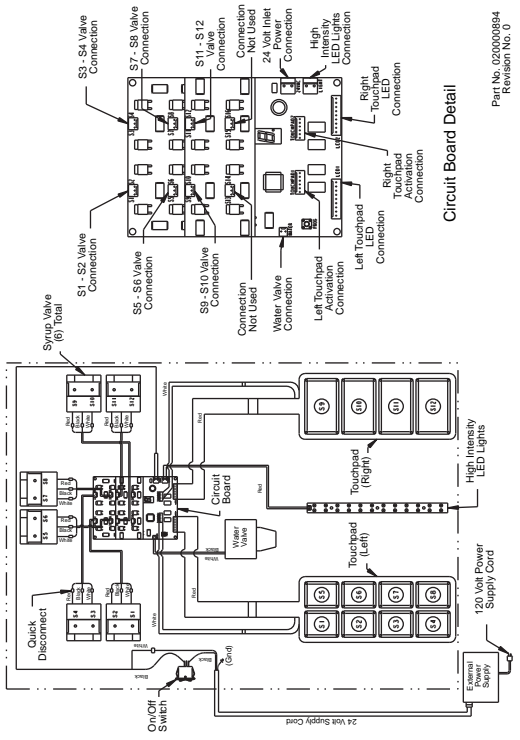

Part No. 020000894
 Revision No. 0

FT-16 WIRING DIAGRAM

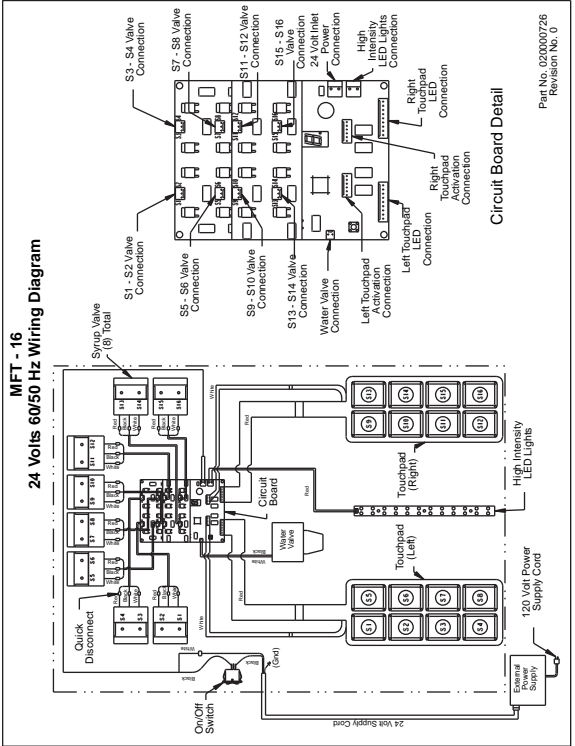

FLEXTOWER POWER SUPPLY

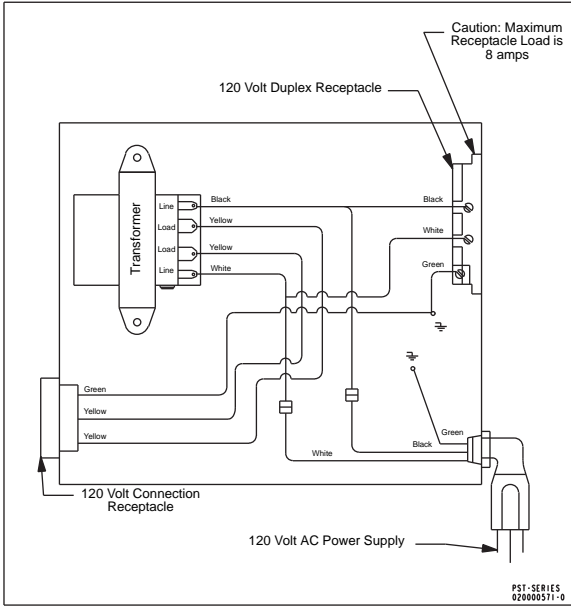

MDH 402 115V WIRING DIAGRAM

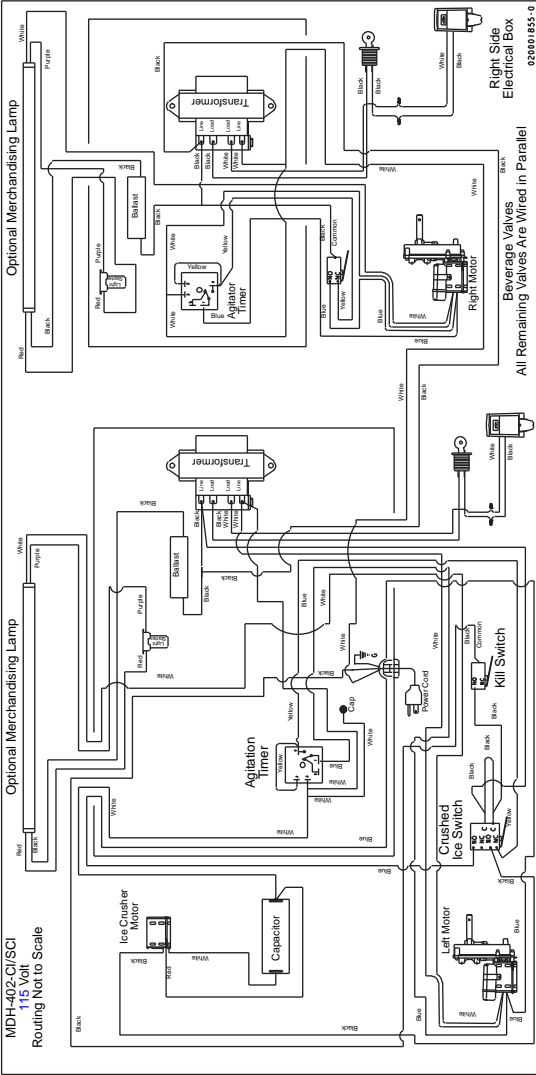

NGF-250 Wiring

NGF-250 115V WIRING DIAGRAM

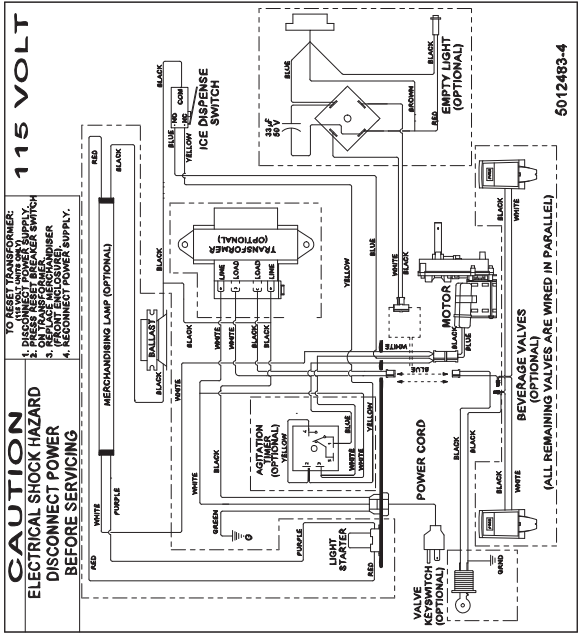

S/SV/SVi Wiring

S-SV-SVI-150/175/200/250 115V 60HZ

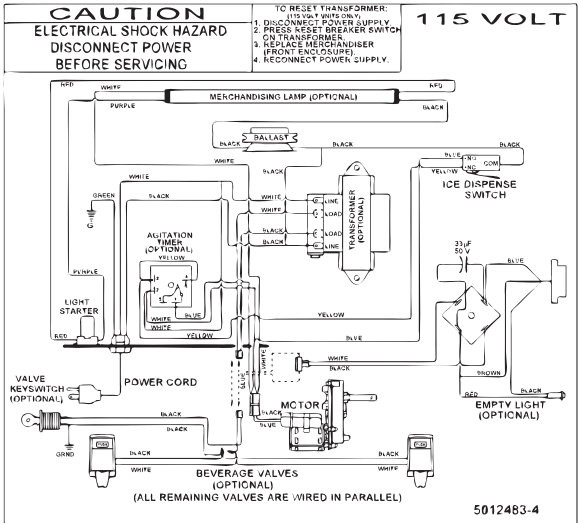

S-SV-SVI-150/175/200/250 100/220-240V 50-60HZ

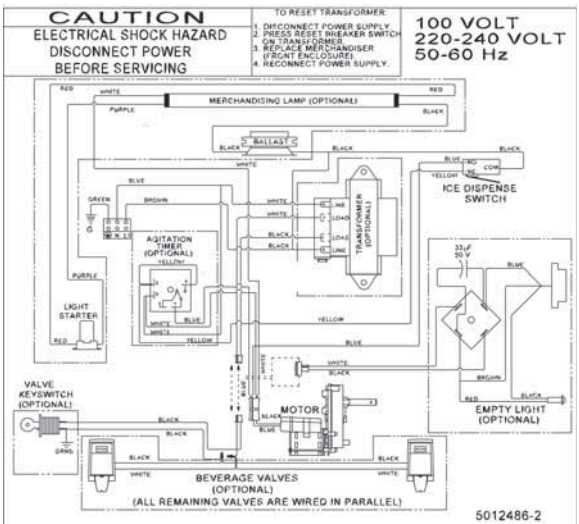

S-SV-SVI-150/175/200/250 220-240V 50HZ C.E.

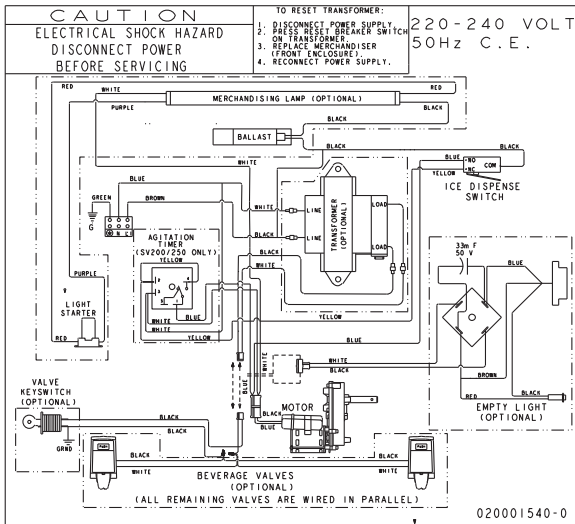

This Page Intentionally Left Blank



Manitowoc Foodservice
2100 Future Drive
Sellersburg, IN 47172, USA
Ph: 812-246-7000 Fax: 812-246-7024
Visit us online at:
www.manitowocfsg.com

© 2010 Maniowoc
Part Number STH14 9/10

