

Post Mix Soda and Super-Chil™ Refrigeration Unit with Electronic Control

Installation, Operation and Maintenance Manual

This manual is updated as new information and models are released. Visit our website for the latest manual.
www.manitowocbeverage.com/us



Safety Notices

As you work on Multiplex equipment, be sure to pay close attention to the safety notices in this manual. Disregarding the notices may lead to serious injury and/or damage to the equipment.

Throughout this manual, you will see the following types of safety notices:

Warning

Text in a Warning box alerts you to a potential personal injury situation. Be sure to read the Warning statement before proceeding, and work carefully.

Caution

Text in a Caution box alerts you to a situation in which you could damage the equipment. Be sure to read the Caution statement before proceeding, and work carefully.

Procedural Notices

As you work on Multiplex equipment, be sure to read the procedural notices in this manual. These notices supply helpful information which may assist you as you work.

Throughout this manual, you will see the following types of procedural notices:

Important

Text in an Important box provides you with information that may help you perform a procedure more efficiently. Disregarding this information will not cause damage or injury, but it may slow you down as you work.

NOTE: Text set off as a Note provides you with simple, but useful, extra information about the procedure you are performing.

Read These Before Proceeding:

Caution

Proper installation, care and maintenance are essential for maximum performance and trouble-free operation of your Multiplex equipment. Read and understand this manual. It contains valuable care and maintenance information. If you encounter problems not covered by this manual, do not proceed, contact Manitowoc Beverage Equipment. We will be happy to provide assistance.

Important

Routine adjustments and maintenance procedures outlined in this manual are not covered by the warranty.

Important

New hose sets must be used when installing this equipment. Old hose-sets should not be reused.

Warning

PERSONAL INJURY POTENTIAL

Do not operate equipment that has been misused, abused, neglected, damaged, or altered/modified from that of original manufactured specifications.

Warning

The installer is responsible to provide a suitable plug meeting all requirements, or a means for disconnection must be incorporated in the wiring according to the wiring rules.

Warning

This appliance is intended to be used indoors in kitchens or back rooms of food/restaurant establishments.

Warning

This appliance is not intended for use by persons (including children) with reduced physical, sensory or mental capabilities, or lack of experience and knowledge, unless they have been given supervision concerning use of the appliance by a person responsible for their safety. Do not allow children to play with this appliance.

NOTE: SAVE THESE INSTRUCTIONS.

We reserve the right to make product improvements at any time. Specifications and design are subject to change without notice.

Table of Contents

Section 1 General Information

Read This Manual	5
Unit Inspection	5
Model Numbers	5
How to Read a Model Number	5
Accessories	6
Special Applications	6
Attention: Marine Installations.....	6
Outdoor Applications.....	6
Serial Plate Location	7
Warranty Information	7

Section 2 Installation

General	9
Dimensions and Clearances — All Models	9
Remote Condenser	10
Safe Installation Dos and Don'ts	10
Location Requirements	11
Clearances.....	11
Ratings.....	11
Kitchen Equipment Installer Representative Responsibilities	11
Requirements for Post Mix Refrigeration Units	11
Installer Instructions	12
Preparation	12
Electrical	12
General.....	12
Minimum Circuit Ampacity.....	12
Electrical Requirements	12
Specifications.....	12
Grounding Instructions.....	13
Plumbing/Water Supply	14
Plumbing Potable Water	14
Plumbing Requirements – General.....	14
Water Supply.....	14
Plumbing Circuit Diagrams — Models 42, 44 and SC1000	15
Plumbing Circuit Diagrams — Models 50 and SC2000	18
Refrigeration Unit Installation	20
Unpacking and Inspecting.....	20
Unit Installation Overview	20
Positioning of Refrigeration Unit.....	21
Equipment Placement.....	21
Electrical Connections	21
Tower Installation	21
Conduit Installation	22
Proper Use of John Guest Fittings	22
Connecting Supply Lines.....	23
Routing Insulated Conduit.....	25
Connecting Insulated Conduit at the Unit.....	25

Table of Contents (continued)

Connecting Insulated Supply Lines.....	25
Insulating Connections.....	27
Aeroquip Connection.....	27
Condenser and Pre-charged Lines Installation.....	27
Remote Condenser Requirements.....	27
Pre-charged Refrigeration Line Requirements.....	28
Connecting the Pre-charged Refrigeration Lines.....	29
Testing.....	29
Testing CO ₂ Circuit for Leaks.....	29
Testing Syrup Circuit (5 gallon tanks only).....	29
Preparing Ice Bank	30
Building an Ice Bank.....	30
Installation Checklist	30

**Section 3
Operation**

Typical System	31
How the Multiplex Works.....	32
Start-Up.....	32
Placing Equipment in Operation	32
Placing the Syrup System in Operation.....	32
Sequence of Operation	33
Electronic Control.....	33
Equipment Setup and Close Procedure.....	36
Equipment Setup Procedure.....	36
Equipment Close Procedure.....	36

**Section 4
Maintenance**

Maintenance Schedule	39
Periodic Maintenance For Equipment (Listed By Major Components).....	39
Cleaning and Sanitizing the Dispensing Valves and Product Lines	40
Cleaning Equipment and Supplies	40
Sanitizing	41
Beverage System Cleaning	41
Bag-In-Box System Sanitation	41
Figal Beverage System.....	42
Back-Flow Preventer Maintenance	43
Shipping, Storage and Relocation	43

**Section 5
Troubleshooting**

Checklist.....	45
Error Notes	46
E1, E2, & E3 Flowchart.....	47
E4, E5, & E6 Flowchart.....	48
E7, E8, & E9 Flowchart.....	49

Section 1 General Information

Read This Manual

Manitowoc Food Service developed this manual as a reference guide for the owner/operator and installer of this equipment. Please read this manual before installation or operation of the machine. A qualified service technician must perform installation and start-up of this equipment. Consult Section 5 within this manual for service assistance.

If you cannot correct the service problem, call your Manitowoc Beverage Equipment (MBE) Service Agent or Distributor. Always have your model and serial number available when you call.

Your Service Agent _____

Service Agent Telephone Number _____

Your Local MBE Distributor _____

Distributor Telephone Number _____

Model Number _____

Serial Number _____

Installation Date _____

Unit Inspection

Thoroughly inspect the unit upon delivery. Immediately report any damage that occurred during transportation to the delivery carrier. Request a written inspection report from a claims inspector to document any necessary claim.

⚠ Warning

PERSONAL INJURY POTENTIAL

Do not operate equipment that has been misused, abused, neglected, damaged, or altered/modified from that of original manufactured specifications.

Model Numbers

This manual covers the following models:

Refrigeration Unit
42MA04, 42 MR04, 42MW04, 42MAX04, 42MRX04, 42MWX04, 44MA04, 44MAX04T, 44MW04, 44MWX04T, 44MR04, 44MRX04T, 44EAX04T, 44EWX04T, 44GA04, 44GAX04T, 44GW04, 44GWX04T, 44GR04, 44GRX04T, SC1000A, SC1000R, SC1000W, SC1000AX, SC1000RX, SC1000WX, 50MA04, 50MAX04, 50MR04, 50MRX04, 50MW04, 50MWX04, 50MR04Q/T, 50GA04, 50GAX04, 50GR04, 50GRX04, 50GW04, 50GWX04, 50GR04Q/T, SC2000A, SC2000R, SC2000W, SC2000AX, SC2000RX, SC2000WX

How to Read a Model Number

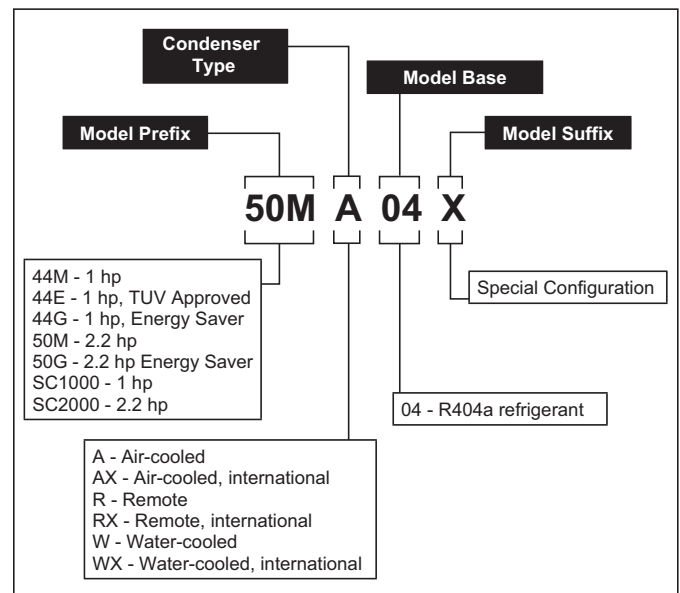

Accessories

Depending on store type and location, various optional equipment (such as CO₂ Panel, water filter kit, water booster kit, etc.) may be added to this system. Install and connect any optional equipment in the desired location according to the installation instructions provided with these kits/equipment.

Special Applications

ATTENTION: MARINE INSTALLATIONS

▲ Warning

This unit is for use on vessels over 66 ft (20 m) in length. This unit must not be installed in the engine space of a gasoline-powered ship.

NOTE: This unit must be secured to the vessel during installation. Models with part numbers beginning with the letters TS are NOT marine listed.

OUTDOOR APPLICATIONS

TS Multiplex Beverage Recirculating units are approved and listed by Underwriters Laboratories (UL). However they are not UL approved for weather exposure applications. These units must be installed in areas where adequate protection from the elements is provided, all other models are ETL listed.

Serial Plate Location

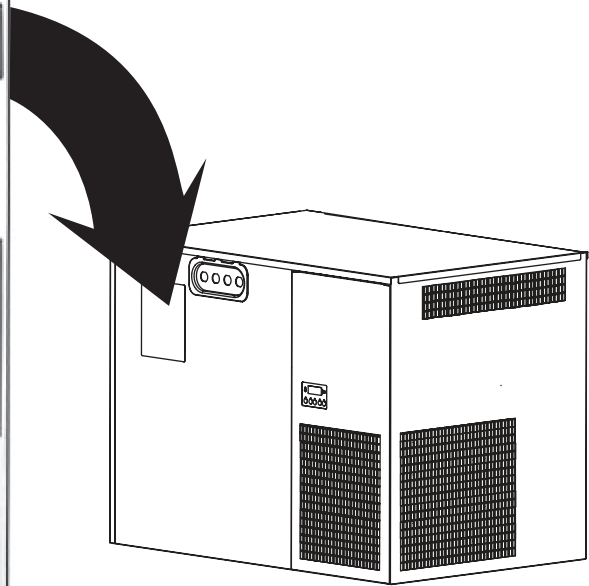
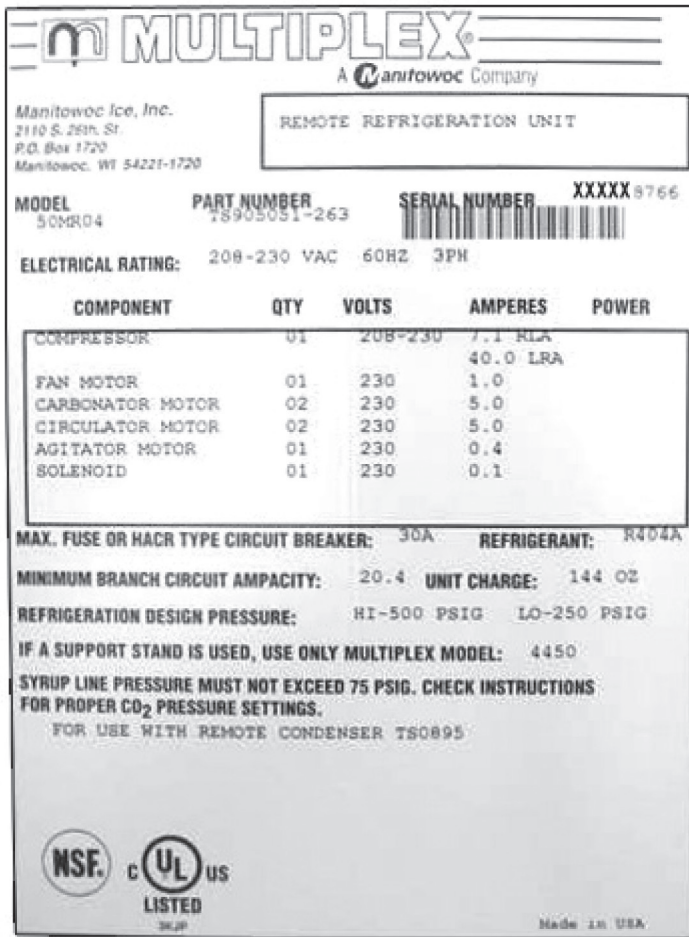

Warranty Information

Consult your local MBE Distributor for terms and conditions of your warranty. Your warranty specifically excludes all beverage valve brixing, general adjustments, cleaning, accessories and related servicing.

Your warranty card must be returned to MBE to activate the warranty on this equipment. If a warranty card is not returned, the warranty period can begin when the equipment leaves the MBE factory.

No equipment may be returned to MBE without a written Return Materials Authorization (RMA). Equipment returned without an RMA will be refused at MBE's dock and returned to the sender at the sender's expense.

Please contact your local MBE distributor for return procedures.

THIS PAGE INTENTIONALLY LEFT BLANK

Section 2 Installation

General

- Refrigeration units require stand or 6" (15.2 cm) legs. Refrigeration unit cannot be placed directly on floor.
- Conduit can be run through floor or ceiling chase.
- Syrup supply can be located on stand or adjacent to refrigeration unit.

Dimensions and Clearances — All Models

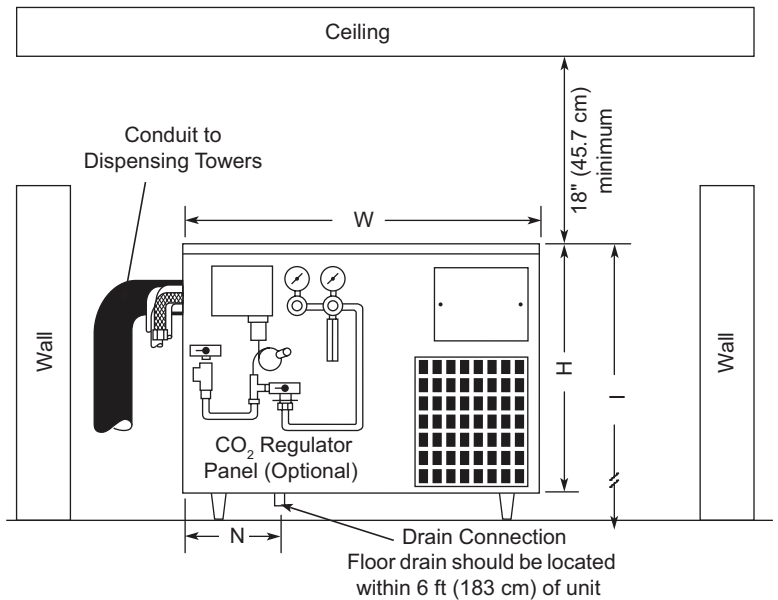
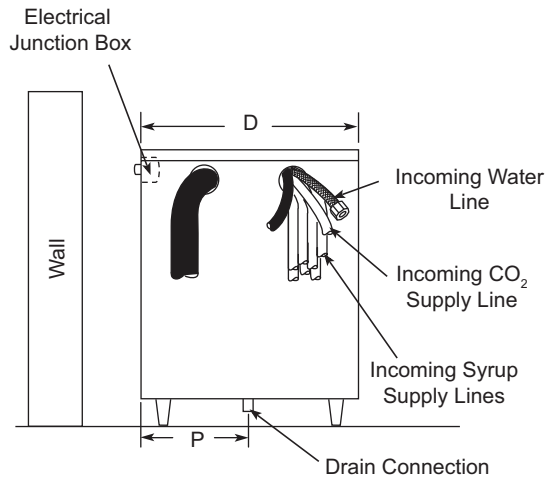
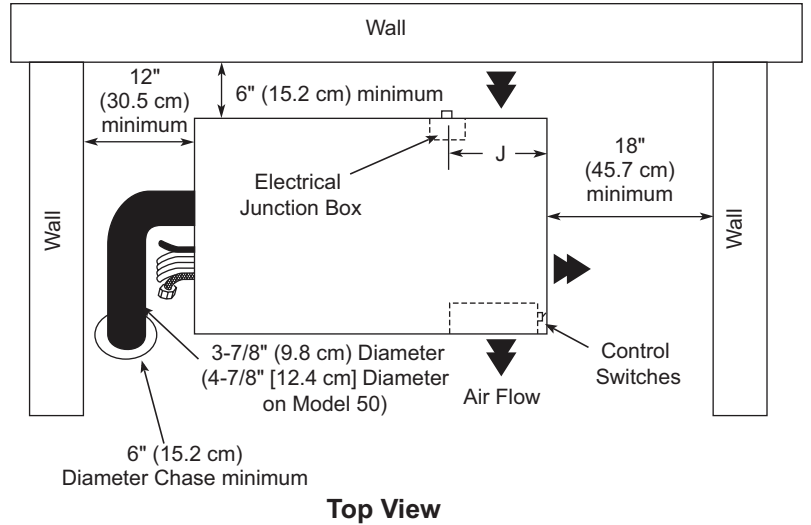
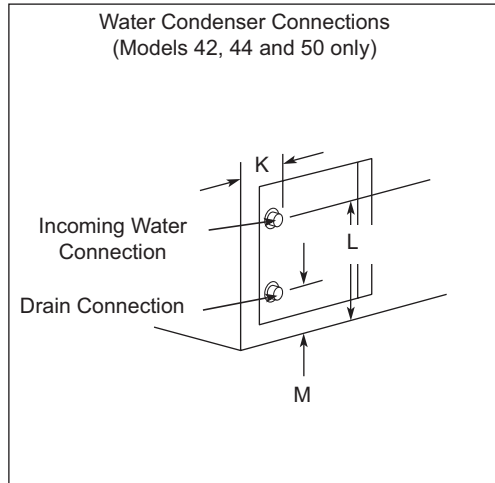

Model	W	D	H	I (with stand)	J	K	L	M	N	P
42, 44 & SC1000	39-3/4" (101 cm)	24-3/4" (62.9 cm)	28-1/4" (72.4 cm)	60-3/4" (154.3 cm)	11" (28 cm)	3-1/2" (8.9 cm)	12" (30.5 cm)	4" (10.2 cm)	6" (15.2 cm)	12" (30.5 cm)
50 & SC2000	42-1/4" (107.3 cm)	28-1/4" (71.8 cm)	32-1/4" (81.9 cm)	66-3/4" (169.5 cm)	11" (28 cm)	4" (10.2 cm)	19" (48.2 cm)	19" (48.2 cm)	8-1/2" (21.6 cm)	14" (35.6 cm)

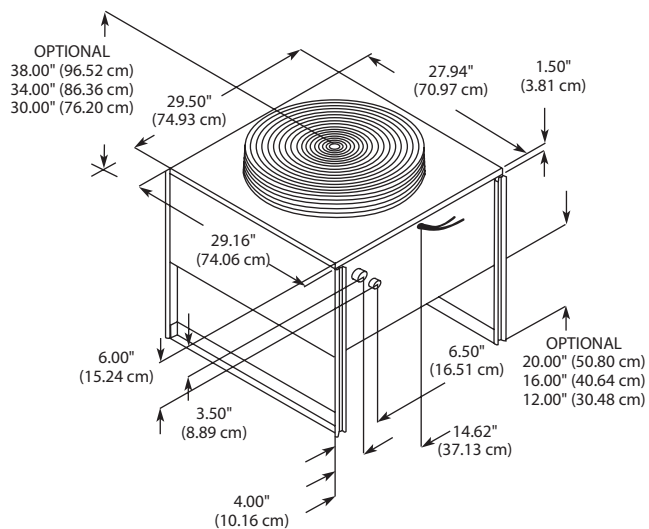
REMOTE CONDENSER

- **DO NOT** exhaust CO₂ gas (example: syrup pump) into an enclosed area, including all types of walk-in coolers, cellars, and closets.
- **DO NOT** throw or drop a CO₂ cylinder. Secure the cylinder(s) in an upright position with a chain.
- **DO NOT** connect the CO₂ cylinder(s) directly to the product container. Doing so will result in an explosion causing possible death or injury. It is best to connect the CO₂ cylinder(s) to a regulator(s).
- **DO NOT** store CO₂ cylinders in temperature above 125°F (51.7°C) near furnaces, radiator or sources of heat.
- **DO NOT** release CO₂ gas from old cylinder.
- **DO NOT** touch refrigeration lines inside units; some may exceed temperatures of 200°F (93.3°C).

NOTICE: All utility connections and fixtures must be sized, installed, and maintained in accordance with Federal, State, and Local codes.

Safe Installation Dos and Don'ts**⚠ Warning**

Read the following warnings before beginning an installation. Failure to do so may result in possible death or serious injury.

- **DO** adhere to all National and Local Plumbing and Electrical Safety Codes.
- **DO** turn OFF incoming electrical service switches when servicing, installing, or repairing equipment.
- **DO** check that all flare fittings are tight. This check must be performed with a wrench to ensure a quality seal.
- **DO** inspect pressure on regulators before starting up equipment.
- **DO** protect eyes when working around refrigerants.
- **DO** use caution when handling metal surface edges of all equipment.
- **DO** handle CO₂ cylinders and gauges with care. Secure cylinders properly against abrasion.
- **DO** store CO₂ cylinder(s) in well ventilated areas.

Location Requirements

CLEARANCES

Control Side (Right)	18" (45.7 cm)
Tower Connection Side (Left)	12" (30.5 cm)
Back Side	6" (15.2 cm)
Ceiling	18" (45.7 cm)

RATINGS

Model	Evaporator Rating at 20°F (-6.5°C)	Heat Rejection (Max.)
Model 42	9,700 BTUH	13,576 BTUH
Model 44	2,340 kcal/hr	3,685 kcal/hr
Model SC1000	9,700 BTUH 2,340 kcal/hr	13,576 BTUH 3,685 kcal/hr
Model 50	14,900 BTUH 3,310 kcal/hr	20,400 BTUH 4,285 kcal/hr
Model SC2000	14,900 BTUH 3,310 kcal/hr	20,400 BTUH 4,285 kcal/hr

Select a location for the refrigeration unit that meets the requirements of the building plans, local codes, and personnel. The unit must be positioned for free airflow as well as for future service. The following requirements must be met:

- 300 GPH (1135 LTR/hr) potable water supply (all models)
- Beverage quality CO₂ gas (bulk or bottled supply) with a minimum 3/8" (0.96 cm) line
- One Bag-In-Box (BIB) container of each post mix syrup flavor.

NOTE: Refer to nameplate on side of refrigeration unit for voltage and amperage specifications. Make all electrical connections at the junction box located at the top rear of unit. Optional equipment may require additional power supplies.

NOTE: Potable water connections to the equipment must comply with local plumbing code requirements, particularly the back-flow prevention requirements.

NOTE: Operating decibel level is above 70db.

⚠ Warning

Carbon Dioxide (CO₂) displaces oxygen. Exposure to a high concentration of CO₂ gas causes tremors, which are followed rapidly by loss of consciousness and suffocation. If a CO₂ gas leak is suspected, particularly in a small area, immediately ventilate the area before repairing the leak. CO₂ lines and pumps must not be installed in an enclosed space. An enclosed space can be a cooler or small room or closet. This may include convenience stores with glass door self serve coolers. If you suspect CO₂ may build up in an area, venting of the BIB pumps and/or CO₂ monitors must be utilized.

KITCHEN EQUIPMENT INSTALLER REPRESENTATIVE RESPONSIBILITIES

Prior to scheduling Multiplex Equipment installer, the following steps listed below must be completed:

1. Usable floor sewer drain.
2. Refer to electrical requirement chart for your model.
3. Usable potable water.
4. CO₂ Gas (bulk or bottled supply); minimum 3/8" line.
5. One 5 gallon (19 L) container or Bag-In-Box container of each post mix syrup flavor.
6. A 120 VAC, 3-wire, 1 Phase, 60 Hz dual wall receptacle for optional electrical equipment (domestic only).

NOTE: Do not schedule the authorized Multiplex Equipment Installer until all of the above have been completed. It will only result in charge-backs to you for the unnecessary trips.

REQUIREMENTS FOR POST MIX REFRIGERATION UNITS

- Conduit can be run through floor or ceiling chase.
- 60°F (15.6°C) minimum and 100.4°F (38°C) maximum operating ambient conditions.
- For indoor installation only.
- Syrup supply can be located on stand or adjacent to refrigeration unit.

Installer Instructions

Important

The remainder of these instructions is to be completed by an authorized Multiplex Installer.

These equipment instructions are intended to assist qualified personnel in the unpacking, locating and the initial operation of the Multiplex Beverage Equipment Post Mix Refrigeration Unit.

Important

This publication must be saved for future reference. Read instructions before attempting installation.

PREPARATION

The Multiplex Beverage Equipment Post Mix Refrigeration Unit is pre-assembled in the factory and requires minimum installation.

For future reference or to be used when ordering parts, record the Model Number, Serial Number, Part Numbers of Unit, Condenser (if remote), Towers, etc., and Date of Installation on the inside of this Manual. Leave manual on site in a safe place. Do not discard manual.

SPECIFICATIONS

Model	Volt/Cycle/ Phase	Minimum Circuit Amps	Breaker	Compressor
42	208-230/60/1	20.6	30A	1 hp
44	230/50/1	20.6	25A	0.75 kW
SC1000	208-230/60/1 230/50/1	20.6 20.6	30A 25A	1 hp 0.75 kW
50	208-230/60/3 230/400/50/3	25.2 11.6	30A 20A	2.2 hp 1.6 kW
SC2000	208-230/60/3 230/400/50/3	25.2 11.6	20A 15A	2.2 hp 1.6 kW

Ambient Location Requirement

This equipment is rated for indoor use only. It will not operate in sub-freezing temperature. In a situation when temperatures drop below freezing, the equipment must be turned off immediately and properly winterized. Contact the manufacturer for winterization process.

Electrical

GENERAL

⚠ Warning

All wiring must conform to local, state and national codes.

MINIMUM CIRCUIT AMPACITY

The minimum circuit ampacity is used to help select the wire size of the electrical supply. (Minimum circuit ampacity is not the beverage/ice machine's running amp load.) The wire size (or gauge) is also dependent upon location, materials used, length of run, etc., so it must be determined by a qualified electrician.

ELECTRICAL REQUIREMENTS

Refer to Ice Machine Model/Serial Plate for voltage/ amperage specifications.

GROUNDING INSTRUCTIONS**⚠ Warning**

The beverage/ice machine must be grounded in accordance with national and local electrical codes.

This appliance must be grounded. In the event of malfunction or breakdown, grounding provides a path of least resistance for electric current to reduce the risk of electric shock. This appliance is equipped with a cord having an equipment-grounding conductor and a grounding plug. The plug must be plugged into an appropriate outlet that is properly installed and grounded in accordance with all local codes and ordinances.

⚠ Warning

Improper connection of the equipment-grounding conductor can result in a risk of electric shock. The conductor with insulation having an outer surface that is green with or without yellow stripes is the equipment grounding conductor. If repair or replacement of the cord or plug is necessary, do not connect the equipment-grounding conductor to a live terminal. Check with a qualified electrician or serviceman if the grounding instructions are not completely understood, or if in doubt as to whether the appliance is properly grounded. Do not modify the plug provided with the appliance — if it will not fit the outlet. Have a proper outlet installed by a qualified electrician.

⚠ Warning

When using electric appliances, basic precautions must always be followed, including the following:

- a. Read all the instructions before using the appliance.
- b. To reduce the risk of injury, close supervision is necessary when an appliance is used near children.
- c. Do not contact moving parts.
- d. Only use attachments recommended or sold by the manufacturer.
- e. Do not use outdoors.
- f. For a cord-connected appliance, the following shall be included:
 - Do not unplug by pulling on cord. To unplug, grasp the plug, not the cord.
 - Unplug from outlet when not in use and before servicing or cleaning.
 - Do not operate any appliance with a damaged cord or plug, or after the appliance malfunctions or is dropped or damaged in any manner. Contact the nearest authorized service facility for examination, repair, or electrical or mechanical adjustment.
- g. For a permanently connected appliance — Turn the power switch to the off position when the appliance is not in use and before servicing or cleaning.
- h. For an appliance with a replaceable lamp — Always unplug before replacing the lamp. Replace the bulb with the same type.
- i. For a grounded appliance — Connect to a properly grounded outlet only. See Grounding Instructions.

Plumbing/Water Supply

PLUMBING POTABLE WATER

Model	Required Water Pressure	Drain Connections	Water Supply
44 & SC1000	40 – 70 psig (2.8 – 4.9 bar) (275790.2912 - 482633.0096 Pascals)	3/4" ID within 6 ft (2 m)	1/2" ID EVA Line
50 & SC2000	40 – 70 psig (2.8 – 4.9 bar) (275790.2912 - 482633.0096 Pascals)	3/4" ID within 6 ft (2 m)	1/2" ID EVA Line

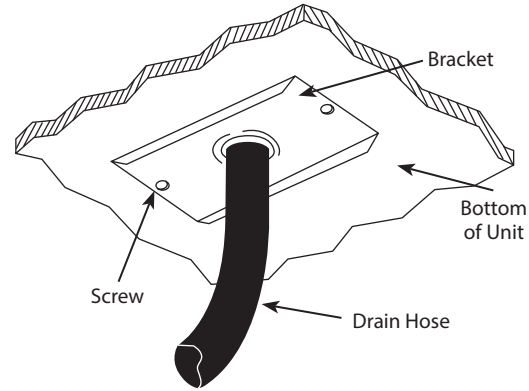

Drain Hose Connection

- When a water-cooled condenser is installed, a copper supply line (not supplied with unit) must be plumbed to the 3/8" male flare fitting installed in the water shut-off assembly. The shut-off must be placed in the OFF position. A copper drain line (not supplied) is to be connected to the outlet fitting of the water cooled condenser and routed to the floor drain.

A 1" ID copper inlet water line equipped with a 3/4" FPT sweat adapter with shut-off must be supplied by plumber at rear of equipment. Appropriate floor drains must be provided within 6 ft (183 cm) of each unit installed.

NOTE: The carbonator(s) in this unit are provided with a vented back-flow preventer that conforms to ASSE 1022.

Potable water connections to the equipment must comply with the basic plumbing code of the Building Officials and Code Administrators International, Inc. (BOCA) and the Food Service Sanitation Manual of the Food and Drug Administration. Verify local plumbing code requirements.

PLUMBING REQUIREMENTS – GENERAL

Incoming water supply must be provided before installation of the refrigeration unit and must comply with local plumbing requirements.

- A minimum 1" (2.54 cm) water supply line with a manual shut-off valve must be plumbed at least 6 ft (183 cm) from the unit. The incoming water supply pressure must not exceed 70 psi static (4.8 bar) (482633.0096 Pascals) and be no less than 40 psi (2.8 bar) (275790.2912 - Pascals) dynamic. If supply water pressure is greater than 70 psi (4.8 bar) (482633.0096 Pascals), a water regulator will be required.
- Locate the drain hose, bracket, and two screws provided in the installation kit. Attach the drain hose to the water bath overflow tube located on the bottom of the refrigeration unit.
- Connect the water manifold supply line, located on the bulkhead panel in the motor compartment to the main water supply. The main water supply shut-off valve must remain in the OFF position. If a water filter is to be installed, connect the line to the outlet fitting of the filter. Plumb according to applicable plumbing codes.

WATER SUPPLY

- Models 42, 44, SC1000, 50 and SC2000 use a 1/2" ID copper water supply with a shut-off, and a 1/2" FPT connection is required for the Brix Pump Box assemblies.
- A 1/4" MF connection can be provided for the water bath fill valve. This is not required if another means of filling the water tank is available.
- An appropriate floor drain is required within 6 ft (2 m) of the unit.
- Potable water connections to the equipment must comply with the basic plumbing code of the Building Officials and Code Administrators International, Inc. (BOCA) and the Food Service Sanitation Manual of the Food and Drug Administration. Verify local plumbing code requirements.

PLUMBING CIRCUIT DIAGRAMS — MODELS 42, 44 AND SC1000

Pressurized Water Circuit Diagram

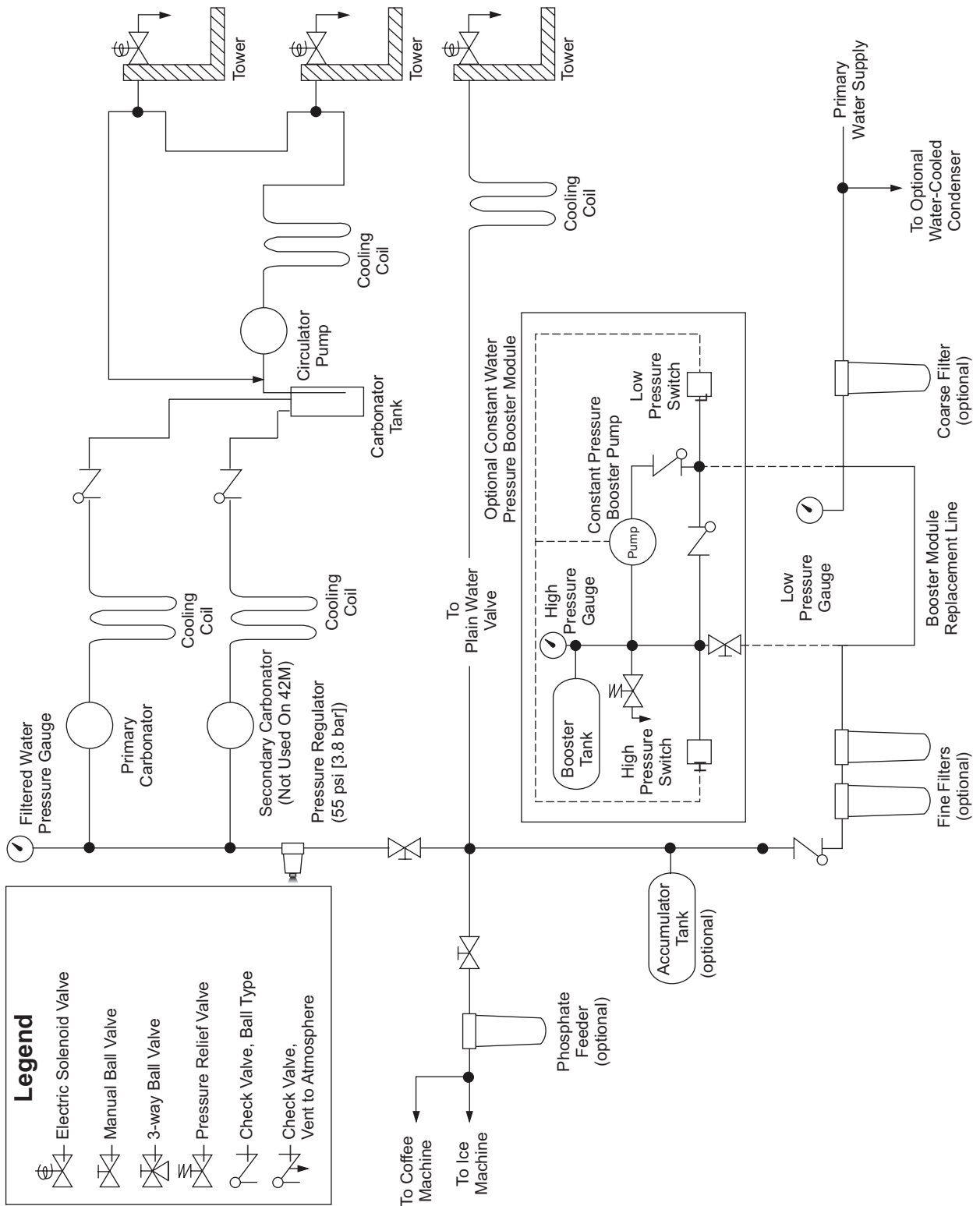

Pre-mix Plumbing — Eight Valve Towers with Connection at Center Island

Single Tower System

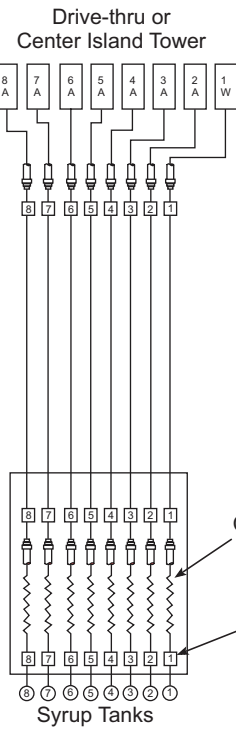

Two Tower System with Connection at Center Island

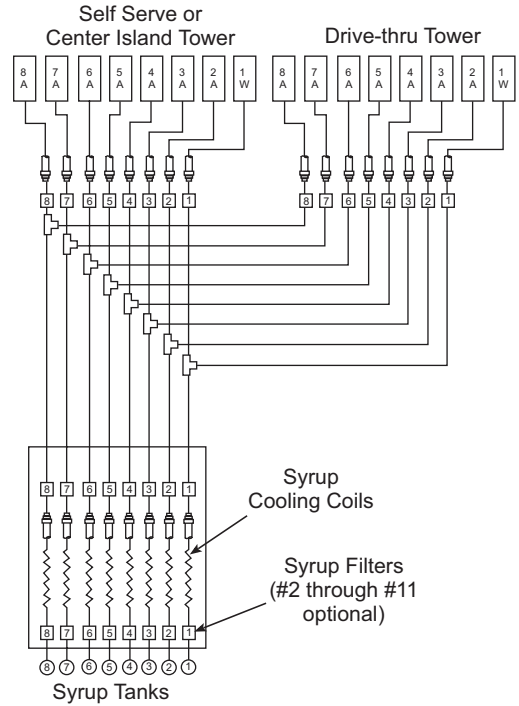

Three Tower System with Connection at Center Island

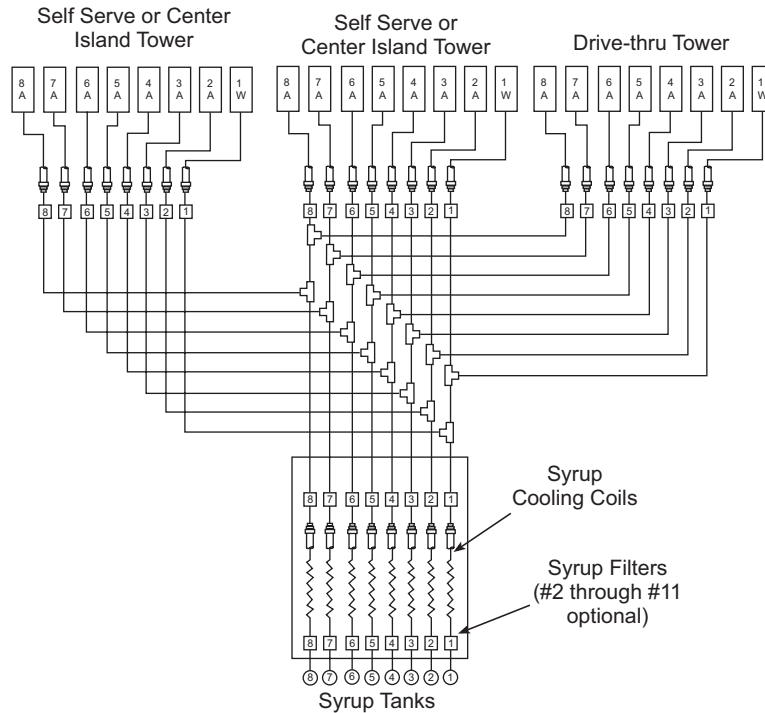

Carbonated Water Plumbing — Eight Valve Towers with Connection at Unit

Single Tower System with Connection at Unit

Drive-thru or
Center Island Tower

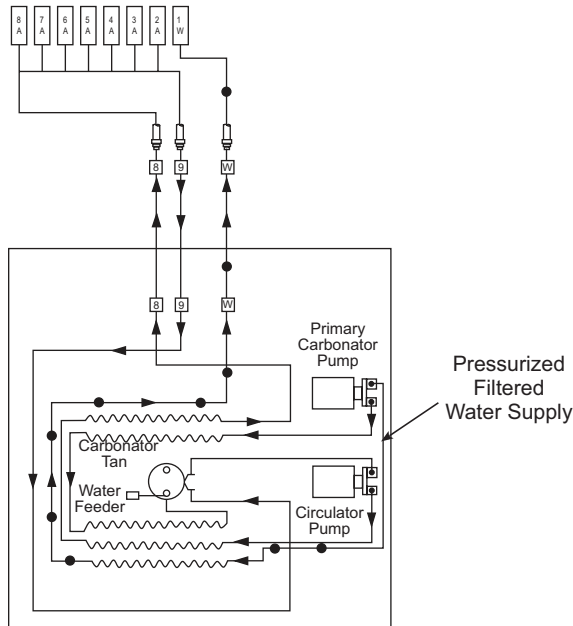

Two Tower System with Connection at Unit

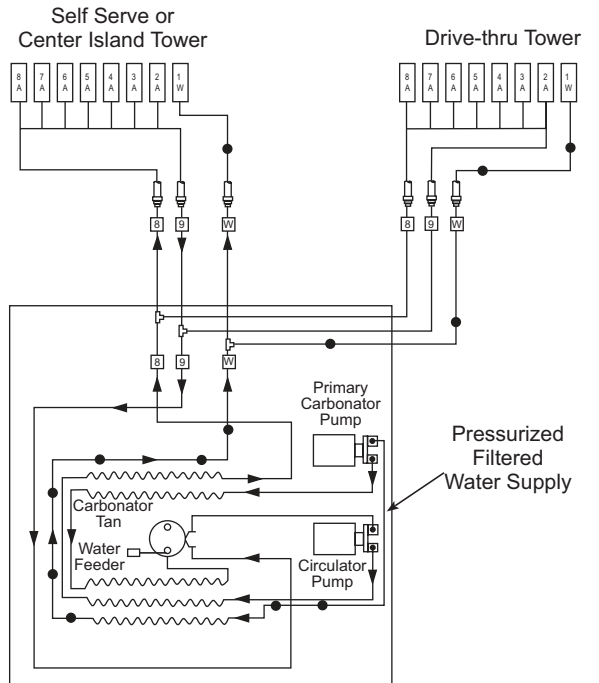

Three Tower System with Connection at Unit

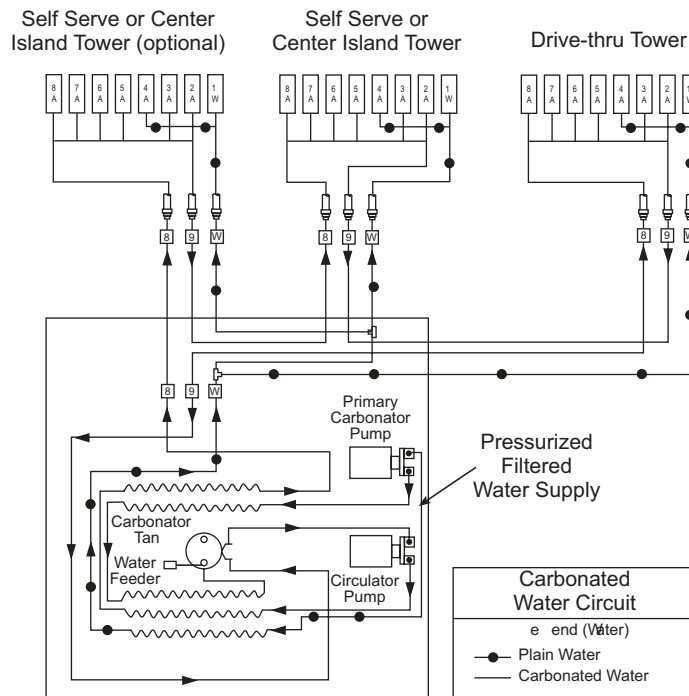

PLUMBING CIRCUIT DIAGRAMS — MODELS 50 AND SC2000

Pressurized Water Circuit Diagram

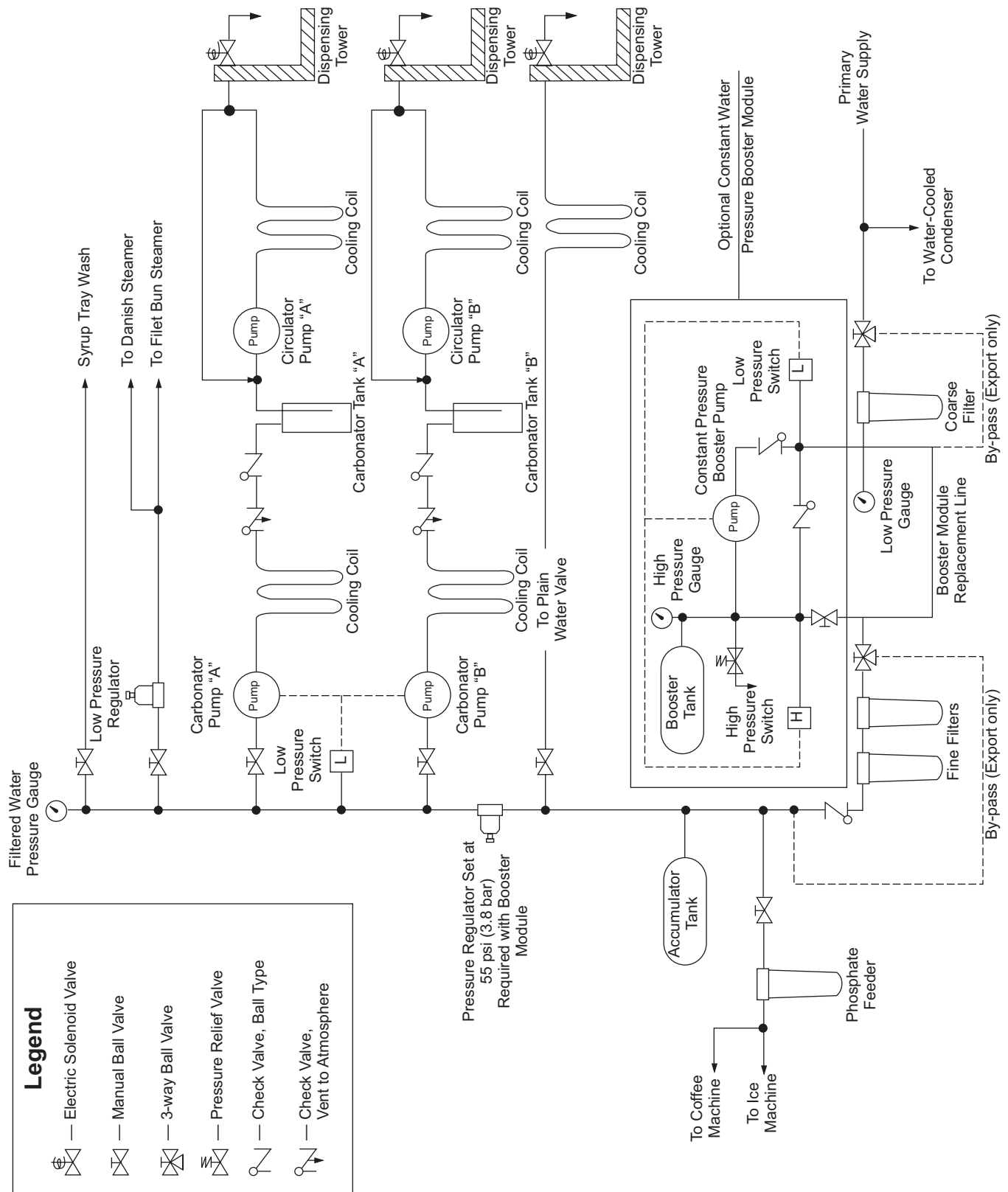

CO₂ Gas and Compressed Air Circuit Diagram

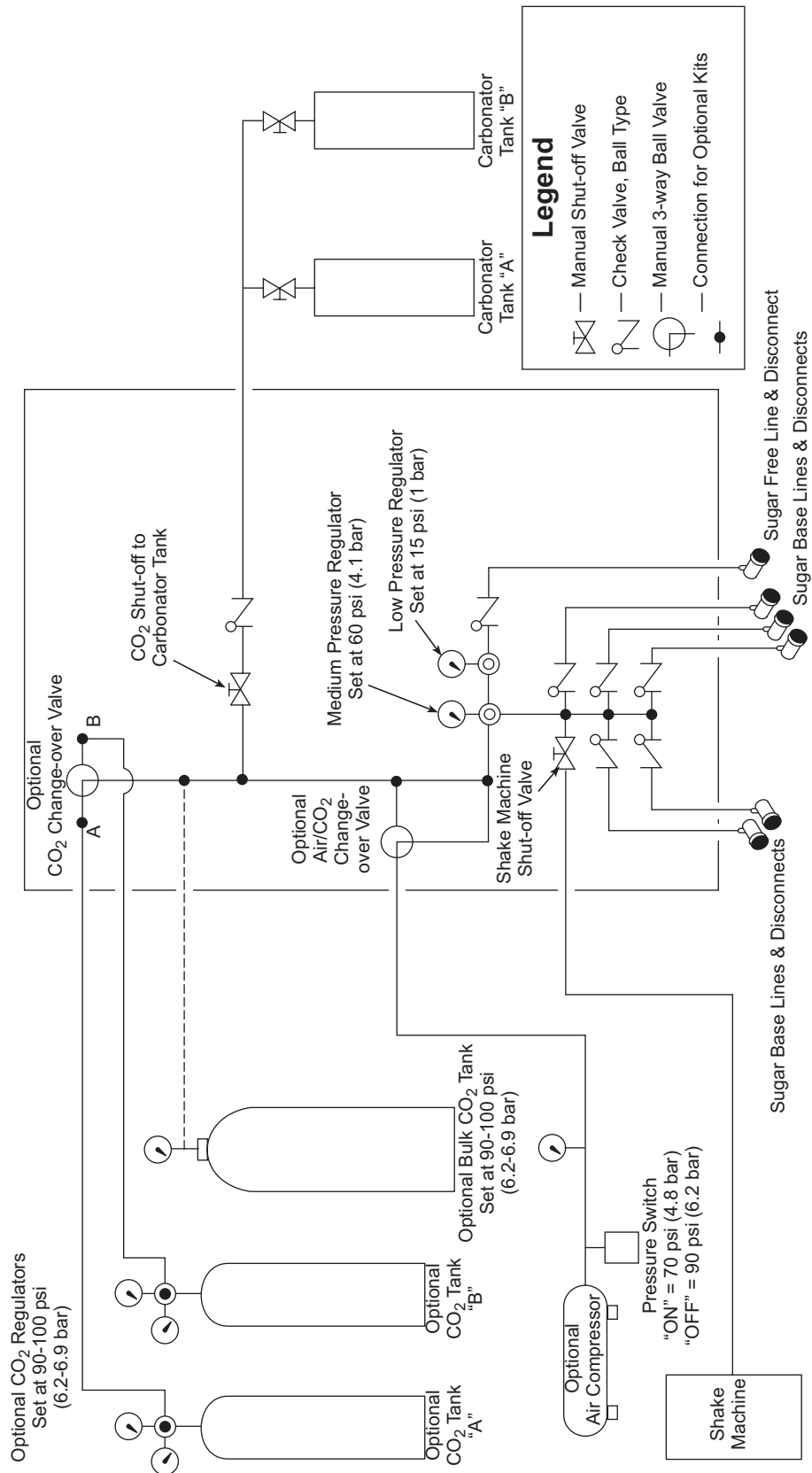

Refrigeration Unit Installation

UNPACKING AND INSPECTING

Carefully inspect the refrigeration unit immediately upon unpacking. Verify the equipment and parts received against the Bill of Lading. Locate all items according to packing list and inspect for possible damage caused by shipping. Notify the appropriate carrier if necessary and contact MBE immediately for replacement of parts if discrepancies exist.

1. The Refrigeration Unit is pre-assembled in the factory and requires a minimum installation. Locate the following parts supplied with the unit.
2. Kit assembly includes:
 - Tab clamps for conduit, syrup and circulating and carbonated water coils
 - Bracket for drain hose and screws for mounting
 - Four 6" legs
 - 6 ft (183 cm) drain hose
3. Locate any of the optional Kit Assembly for mounting to match the type of mounting required. Install the kit as noted in the instructions supplied.
4. Record the Model Number, Serial Number and date of installation for future reference, or to be used when ordering parts.

UNIT INSTALLATION OVERVIEW

1. Set unit in place.
2. Connect the circuit electrically. Refer to chart.
3. Connect water supply.
4. Connect the product lines from the Bag-In-Box or tank. See the plumbing diagrams for the tower setup that pertains to your installation.
5. Connect the drain. Locate the drain hose, bracket, and the two screws provided in the installation kit. Attach the drain hose to the water bath overflow tube located on the bottom of the refrigeration unit. Route drain hose to a floor drain.

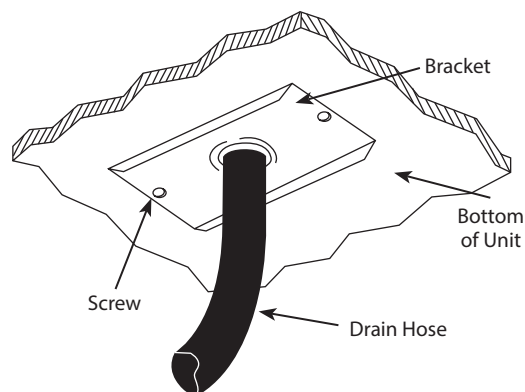

6. Connect the conduit lines. Two carbonated water lines and two product output lines.

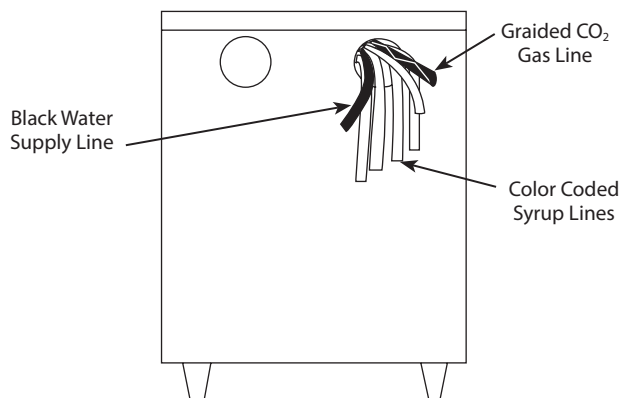

POSITIONING OF REFRIGERATION UNIT

Before proceeding with installation, verify that all requirements for roof mounted Remote Condenser units have been satisfied (if applicable). Refer to the instructions on installing the Remote Condenser supplied with the unit.

If unit is to rest on floor, locate four 6" (15.2 cm) adjustable legs (optional). Screw and tighten legs into the bottom of the refrigeration unit. Set unit in desired location and adjust legs until unit is level and sturdy. If unit is to be mounted on stand, position stand and secure unit to stand. If unit is to be installed on a wall mount bracket, install wall mount bracket and position unit on bracket at this time. Fasten unit to bracket with bolts provided.

EQUIPMENT PLACEMENT

NOTE: All Refrigeration Units must be mounted on either 6" legs or optional stand.

1. Move the stand/refrigeration unit to the designated area and position it near the wall at a distance of at least 6" (15.2 cm) for air circulation in air-cooled units, or at a distance required by local code.
2. Level the stand/unit by adjusting the leg levelers provide on the legs or stand.
3. If unit is equipped with optional stand, lift the Refrigeration Unit onto the stand. Position the unit in the center of the stand. Be sure to orientate the drain of the refrigeration unit with the drain access hole of the stand. Secure with 5/8"-11 x 1" bolts supplied in kit, use two (2) bolts diagonally. Schedule the plumber and electrician to connect the water supply and electrical service if you have not already done so (refer to Electrical Requirements and Plumbing Requirements for plumbing and electrical requirements listed in these instructions).
4. Mount any optional equipment at this time. Follow the installation instructions for each kit required.

ELECTRICAL CONNECTIONS

Caution

Make sure power supply to unit is turned off.

NOTE: The electrician must refer to the nameplate and wiring schematic on the refrigeration unit for correct electrical requirements. All wiring must comply with all safety codes. Make sure all refrigeration unit power switches are in the OFF position.

1. Remove junction box cover.
2. Route and connect power supply to leads in the electrical junction box at the top rear of the motor compartment.

NOTE: Be sure to connect ground wire(s) to ground screw located on back panel of junction box.

3. Replace junction box cover.

Tower Installation

1. Locate placement of tower on the countertop per restaurant design. Verify counter has been prepared to accept the tower via mounting holes. Refer to tower specs for verification.
2. Mount tower with mounting hardware.

Conduit Installation

PROPER USE OF JOHN GUEST FITTINGS

This unit has a compression type tube connector. The following are step-by-step instructions on how to properly use these fittings. For connecting purposes, all connections are furnished with a 3/8" barb connector.

1. Before inserting tubing into a John Guest fitting, be sure end of tubing is cleanly and squarely cut.

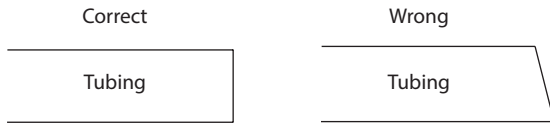

Proper Tubing Cut

2. Lubricate O-ring with water. Insert tubing into John Guest fitting. Push tubing firmly through fitting until it rests against the tube stop in the fitting's main body housing. The tubing is now locked into the John Guest fitting.
3. To release tubing from John Guest fitting, slide collet cover up tube and push in collet. Pull tubing out.
4. Neatly route syrup lines, braided CO₂ gas line and the black incoming water line through the inlet opening on the left side of the refrigeration unit. Do not allow any of these lines to rest on the agitator motor or any other surface that may become hot.
5. Attach the black water supply line to the water filter or a filtered water supply. A 3/8" barb fitting and tab clamp, reducer bushing and 3/8" male pipe x 1/2" OD John Guest tube adapter are provided in the installation kit for making this connection.
6. Route the numbered syrup lines to the syrup supply (syrup tanks, Bag-In-Box, or bulk syrup). Do not attach lines to syrup supply at this time. Lines will be attached to syrup supply after system is tested for leaks.
7. Attach the braided CO₂ line with swivel nut to a regulated CO₂ supply. Use nylon water provided in installation kit. NOTE: do not turn ON CO₂ supply to system at this time.

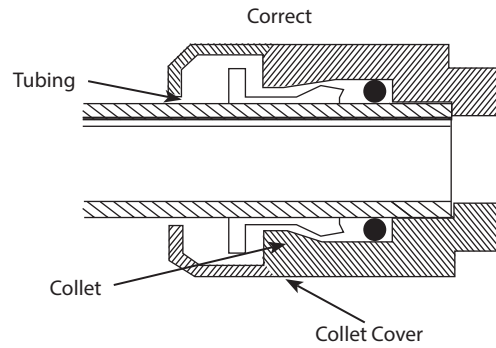
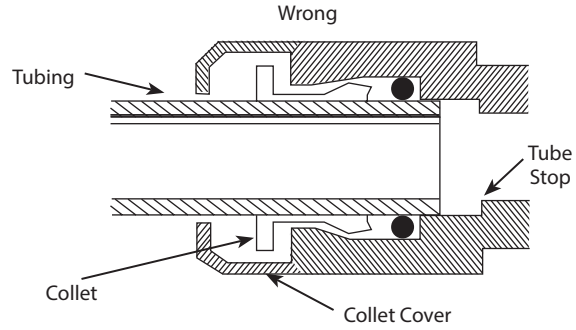

Proper John Guest Fitting Installation

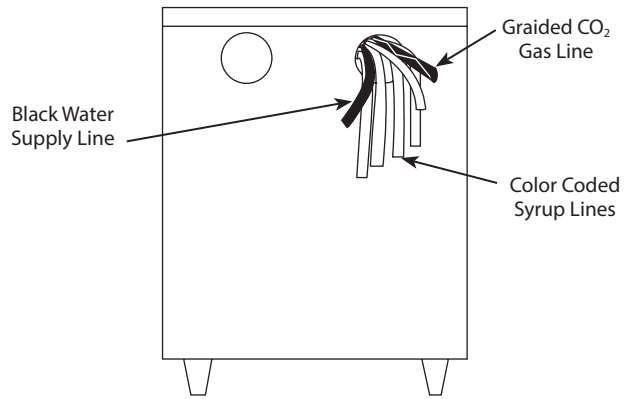

CONNECTING SUPPLY LINES

Pre-installation of towers is required and the appropriate syrup supply must be connected to the corresponding tower. The valves are numbered 1-6, 1-8, or 1-10 from left to right viewing from the front of the tower.

1. For a two (2) tower installation, refer to the Syrup Supply Line Diagram below. The syrup product supply boxes can be positioned on a BIB rack in a convenient location near the soda system.

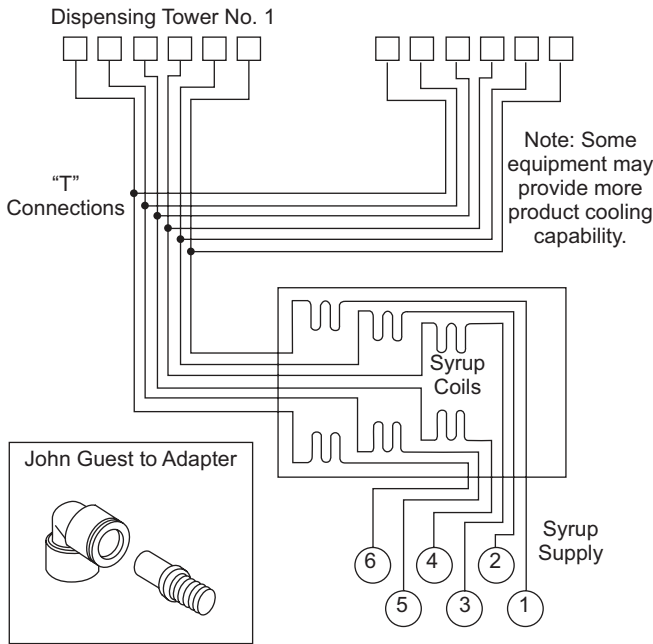

Syrup Supply Line Diagram (Valve #6 Water Only)

NOTE: Refer to the optional equipment component installation instructions for completion (if applicable) of the beverage system. Do not connect the syrup supply at this time.

2. Locate the conduit supply lines for the refrigeration unit. There are four (4) 1/2" (1.27 cm) carbonated water lines marked in sets for the system. Connect the yellow carbonated water supply line (7) to the yellow carbonated water return line (A). Connect the blue carbonated water supply line (8) to the blue carbonated water return line (B). Refer to the Carbonated Water Supply Line Diagram below.

Two Circulation Pumps – Two Circuits

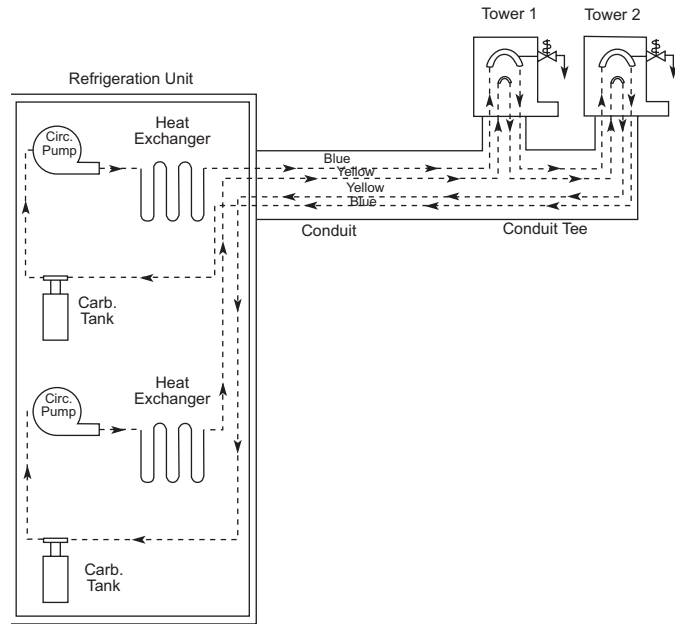

Interlaced Tower

Two Circulation Pumps – Two Circuits

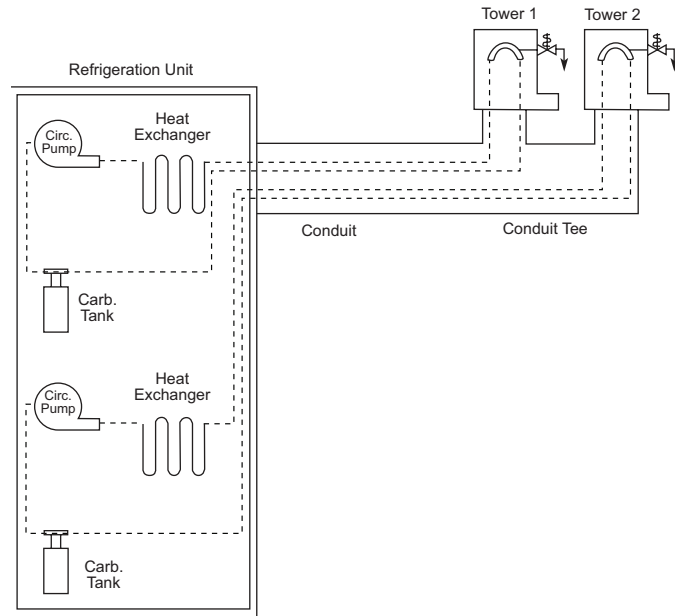

Non-interlaced Tower

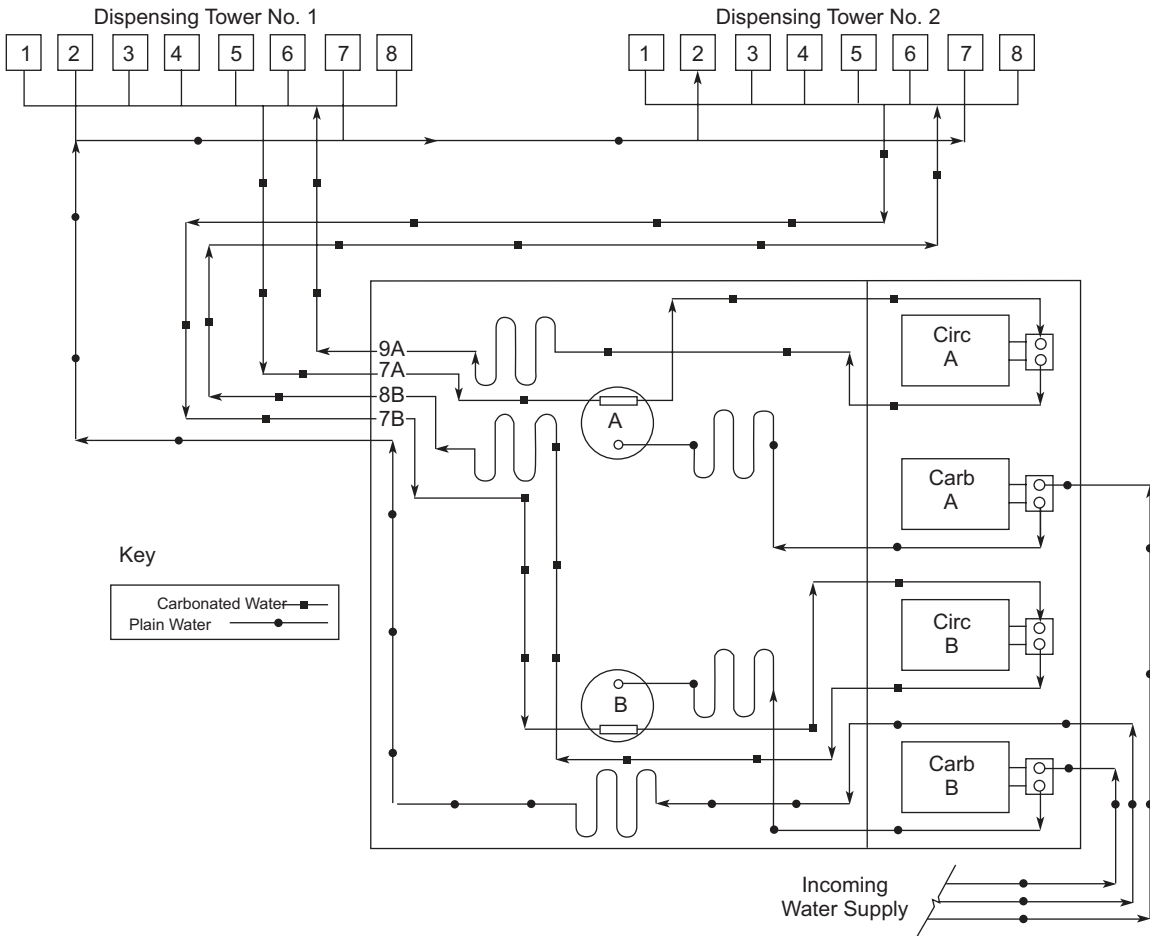

Carbonated Water Supply Line Diagram

3. Locate the #1 and the #8 3/8" (9.5 mm) syrup lines.
NOTE: Braided syrup lines located inside the conduit bundle are used to prevent flavor transfer. Braided syrup lines located outside the conduit bundle are used for unsweetened tea or syrup that are like to precipitate (if applicable).
4. Insert the eight John Guest adapters into the elbows on the syrup coils. NOTE: The 3/8" (9.5 mm) and 1/2" (13 mm) adapters are supplied for either size conduit.
5. Locate the plain water line(s) in the conduit. Determine the size, either 3/8" (9.5 mm) or 1/2" (13 mm) and the number (1 or 2). Jumper the line labeled "W". Either connect two splicers for two water lines or use one of the tees supplied to connect the two lines together.
6. Insert the conduit supply lines into the left hand opening of the refrigeration unit. Connect the John Guest fittings requiring the longest tube from the end of the insulation first. Use two tab clamps each per connection. It may be necessary to moisten the lines and fittings before inserting the tubing over the barbed

fitting. Alter the remaining lines to make the routing neat and secure.

7. Connect the CO₂ supply line from the CO₂ tank regulator to the line marked CO₂ in the unit using a 3/8" (9.5 mm) by 3/8" (9.5 mm) splicer and secure with Oetiker clamps.

Proceed with the Following Tests

- Ensure that overflow tube is firmly seated, not leaking.
- Check conduit for proper support and insulation.
- Cycle carbonator "A" momentarily.
- Cycle carbonator "B" momentarily (if applicable).
- Cycle circulating Motor "A" momentarily.
- Cycle circulating Motor "B" momentarily (if applicable).
- Cycle compressor momentarily.
- Ensure that agitator motor is running.
- Ensure that ice bank control probe is securely attached to evaporator coil.

ROUTING INSULATED CONDUIT

1. Before connecting conduit, evaluate store situation and lay out how the conduit will be routed. Be sure to route conduit away from traffic areas, moving parts, and heat sources.
2. Physically route conduit per evaluated plan. Examine conduit routing and check for neatness, kinks, and interferences.

CONNECTING INSULATED CONDUIT AT THE UNIT

NOTE: List what color line was connected to which product so it can be connected correctly at the towers.

1. Route the conduit to the front opening and into the unit. Cut the insulation back from the lines inside the water bath.
2. Connect the circulating water by connecting one line to the circulating pump outlet line (3/8" barb) and clamp in place. Connect the other line to the bulkhead return fitting located by the agitator motor (3/8" barb) and clamp in place.

CONNECTING INSULATED SUPPLY LINES

Connecting the insulated beverage conduit at the refrigeration unit

1. Route the Multipar beverage conduit from the refrigeration unit to the dispensing station(s) according to the instructions enclosed with the conduit kit. Always route the conduit in a neat and orderly manner.
2. Insert the Multipar conduit into the outlet opening on the left hand side of unit. Conduit insulation must extend inside of opening in unit for proper operation of equipment.

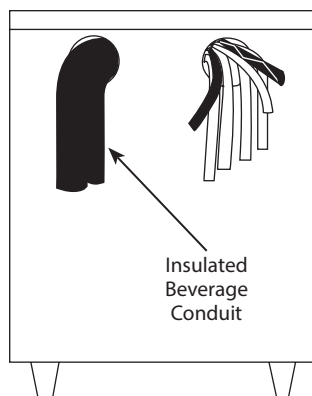

NOTE: Multipar conduit is color coded for easy identification of lines. When making connections always attach lines requiring the longest connection from the insulation first. The remaining lines can be trimmed as required to make the routing neat and secure.

3. Locate the two blue carbonated water lines of the Multipar conduit. Attach one of the blue lines to the tee fitting located on top of the carbonator tank. Attach the other blue line to John Guest elbow fitting on the stainless coil labeled "8".
4. Locate the black plain water line of the Multipar conduit. Attach this line to the elbow fitting on the stainless coil labeled "W".
5. The remaining lines of the Multipar conduit are syrup supply lines and must be attached to the appropriate elbow fittings on stainless steel syrup coils. Note the numbered lines attached to the opposite end of each syrup coil when making connections.

Models 44 & SC1000 Components

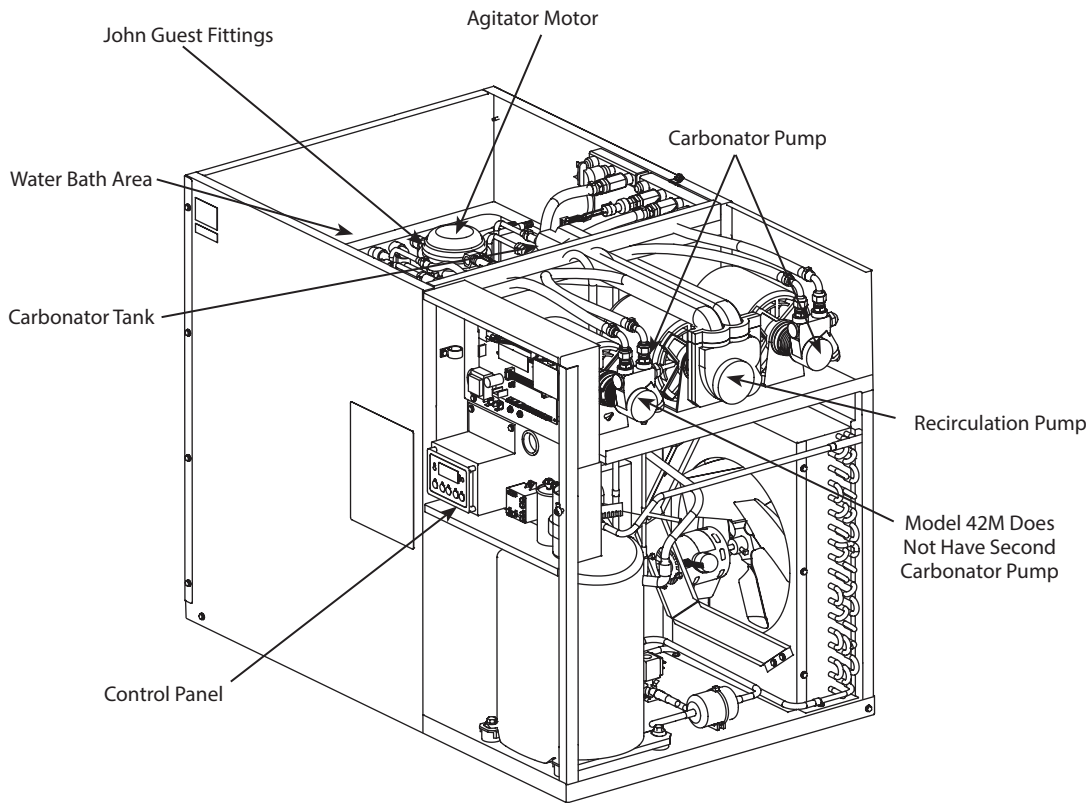

Model 50 & SC2000 Components

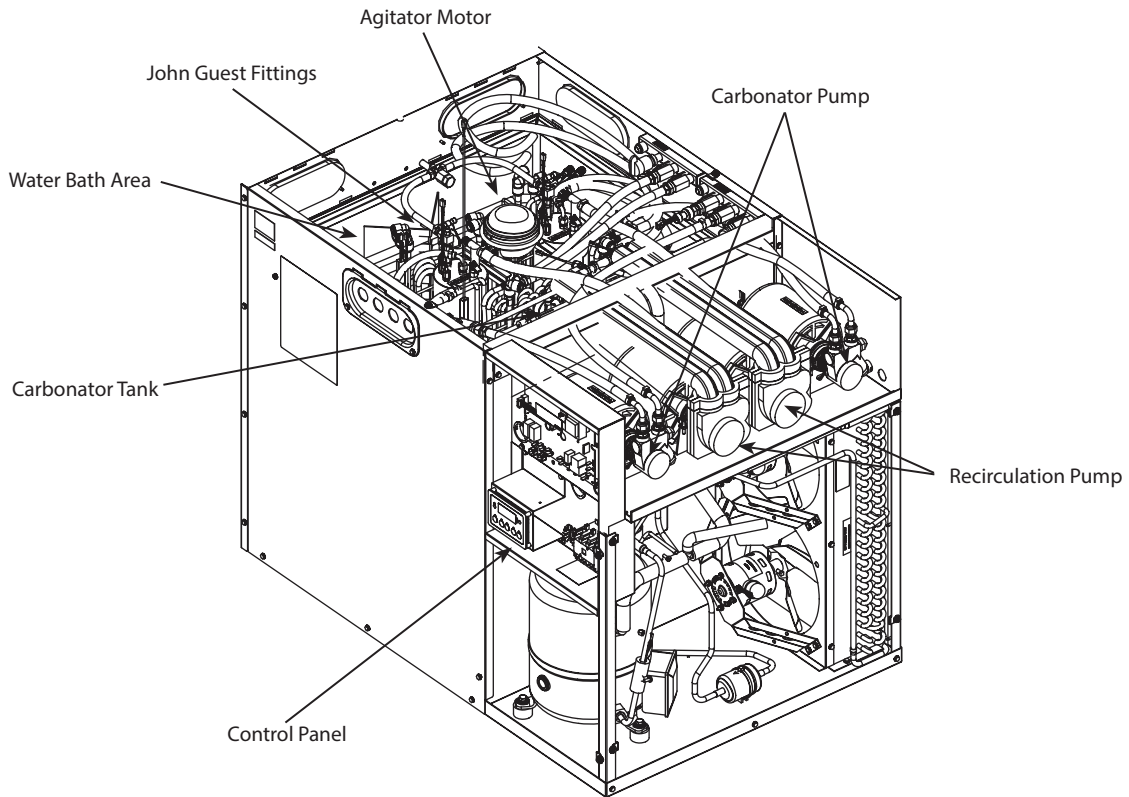

INSULATING CONNECTIONS

1. Make sure all exposed carbonated water and syrup lines are well insulated on towers to conduit, conduit junctions, refrigeration unit to conduits, and drivethrough junction.
2. To insulate the above, use the leftover conduit sections and tape.
3. Cut the conduit sections to fit snugly over the exposed lines and fittings. A little extra time spent doing a thorough job initially will eliminate a call back in several days to make corrections.

NOTE: Do not inject foam material directly on the connections where the tubing connects to the barb fittings or directly on poly tubing.

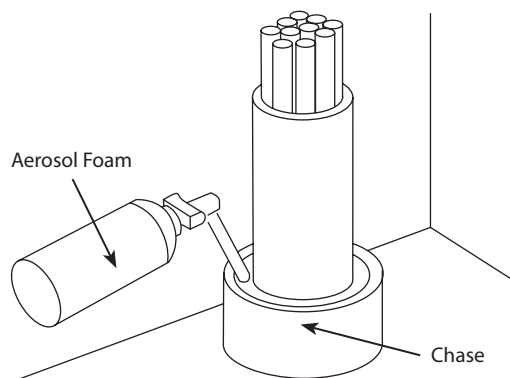

4. The can of foam is to be used to fill the openings between the conduit insulation and the inside diameter of the floor chases. The purpose is to provide an air tight seal at the floor level to prevent foreign matter from entering the chases. Please read the foam manufacturer's instructions carefully. We recommend using the adapter with the right angle extension.
5. Insert the adapter into the openings approximately 1" to 2" (2.5 to 5.1 cm) while depressing the adapter.
6. Move the extension around throughout the area where the foam is to be placed. Do not over fill, allow room for expansion. If the chase opening is too deep, insert a section of the leftover conduit insulation in the opening prior to using the foam insulation.

Aeroquip Connection

1. Lubricate male half diaphragm and synthetic rubber seal with refrigerant oil.
2. Thread male coupling to its proper female half by hand to ensure proper mating of threads.
3. Use proper wrenches (on coupling body hex and its union nut) and tighten union nut until coupling bodies "bottom".

NOTE: You must use a wrench on the body to keep the body from turning while tightening the nut with the second wrench. If the body turns excessively, the piercing seal will be damaged.

4. Use proper wrenches to tighten an additional 1/4 turn (90°). This final 1/4 turn is necessary to ensure the formation of a leak proof joint. Alternately, use a torque wrench to tighten the 1/2" coupling to 40 ft-lbs and 3/8" fitting to 11 ft-lbs.
5. Leak check all your connections. If you detect any leaks, repair and recheck.

Condenser and Pre-charged Lines Installation

Before proceeding with installation, verify that all requirements for roof mounted remote condenser units (if applicable) have been satisfied. If unit has a remote condenser, refer to the instructions on installing the remote condenser supplied with the condensing unit and refer to the section on installation of remote refrigeration line sets.

⚠ Caution

If you are installing a remote unit, there is a refrigeration king valve located behind the compressor. This valve must be back-seated prior to starting the compressor. Failure to do so will short cycle and may damage the compressor.

REMOTE CONDENSER REQUIREMENTS

APPROVED CONDENSERS
Multiplex Condenser - TS0895-271
MAC Multi-Pass Condensers

1. Installation and maintenance are to be performed only by qualified refrigeration personnel. These technicians must have EPA certification (USA), must be familiar with local codes and regulations, and must be experienced with this type of remote refrigeration equipment.
2. As a condition of the warranty, the check, test and start-up procedure must be performed by qualified personnel. Because of possible shipping damage, check both the condensing unit and refrigeration unit(s) for refrigerant leaks.
3. If the refrigeration unit is located on a roll out platform, you must coil up to one round between the back of the stand and the wall. This allows pull out of the refrigeration unit for servicing.
4. If the refrigeration unit is located in a stationary location, you must remove excess refrigeration tubing as described below.

PRE-CHARGED REFRIGERATION LINE REQUIREMENTS

Important

If you have a MAC Multi-Pass condenser, please add three (3) pounds additional charge.

1. Both the discharge and liquid remote condensing lines must be kept to a minimum distance for maximum performance. All Multiplex systems are capacity rated to 100 ft (30.5 m) tubing distance between the compressor and condenser. If you have another brand condenser, please add additional charge for the condenser (example: up to three (3) pounds for a MAC condenser).
2. Any vertical rise 25 ft (7.6 m) or greater must have a manufactured or installed trap (bend), in the discharge refrigeration line from the compressor to the remote condenser. A trap is necessary for every additional 25 ft (7.6 m) vertical rise. When excessive vertical rise exists, this trap allows oil to reach the condenser and return to the compressor.
3. The easiest method to create a trap is to bend the tubing (smoothly, no kinks) into the trap form.

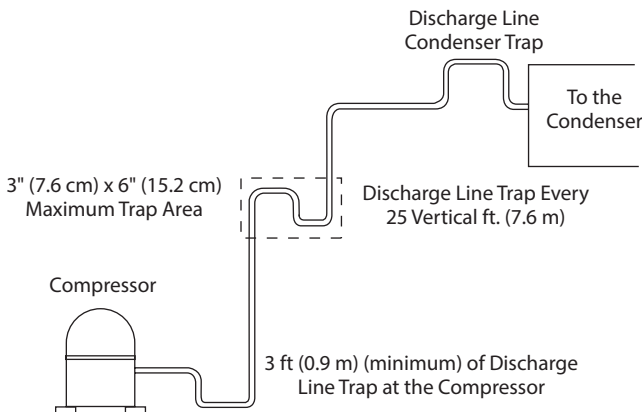

4. The trap(s) must be of minimum height of 3" (7.6 cm) and a width of 6" (15.2 cm) to minimize oil accumulation. The traps can also be bent out of the refrigeration tubing. Carefully bend the tubing down 12" (30.5 cm), and then sweep the tubing back up.
5. It is critical that the Multiplex remote condensing line size specifications for the specific model be maintained. The specifications are 1/2" discharge and 3/8" liquid lines.

Installing the Multiplex Remote Condenser

The Multiplex remote condensing units have a 208-230 Volt, 50/60 HZ, 1 PH fan motor that includes a permanent split capacitor and internal overload protection. The electrical wires from the refrigeration unit wire to the condenser. The electrical installation must be in accordance with local codes, National Electrical Code and regulations.

1. Determine a position for installation that will allow access for maintenance and is free from obstruction. Verify hot air discharge from other condensers does not interfere with the inlet of this condenser.
2. Install the four legs to the sides of the condenser using the mounting bolts provided.
3. The General Contractor or Owner must secure two treated lumber 4" x 4" x 36" (or longer). You may then mount the remote condenser to the treated lumber.
4. The General Contractor or Owner must install a 3" pitch pot in the roof. Then seal for weather protection.

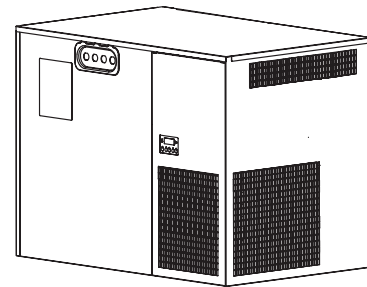
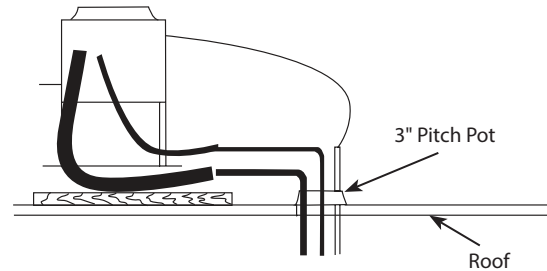

5. Locate the pre-charged refrigeration lines shipped with the system. These lines must be a correct length for the building design. Avoiding any kinks, neatly route these lines from the remote condenser to the refrigeration unit. Excess refrigeration tubing must be handled in one of two ways. When coiling the excess tubing, make sure the inlet to the coil is at the top of the coil and the exit is the bottom of the coil. There can be no more than one turn to the coil. If you have more tubing, you must cut out the excess before connecting the ends. When cutting the tubing, you must first evacuate the refrigerant (line sets have a positive refrigerant holding charge of two to three ounces). After shortening and welding the tubing together again, you must evacuate the tubing to 250 microns. Then recharge the tubing with 4 ounces of appropriate refrigerant.

Caution

Excess refrigeration tubing must be properly cared for before being connected to either the remote condenser or the refrigeration unit.

CONNECTING THE PRE-CHARGED REFRIGERATION LINES

Important

When the connections are made, the seal in the couplings are broken and if removed for any reason, the refrigerant charge will be lost.

NOTE: Before connecting the pre-charged refrigeration lines, the refrigeration unit must be properly located, leveled, and the water bath filled 1" (2.5 cm) below the installed drain pipe.

1. Attach low side gauge set to service port on each line set to verify positive pressure within the line set.

NOTE: If for any reason the lines are damaged and/or leaking, the lines are no longer charged or if the line set is too long for the application, refer to "Installing the Multiplex Remote Condenser".

2. Always make the connections at the condenser first, using the end of the pre-charged lines with the valve ports.
3. Connect the condenser side with the quick connectors (discharge and liquid) up to condenser. Refer to the section titled "Aeroquip Connection" in these instructions.
4. Connect the refrigeration unit side with the quick connects (discharge and liquid). Make sure to provide a discharge trap at back of refrigeration unit, or bend discharge line down 12" and then up smoothly (no kinks) to provide a trap.
5. If a low refrigerant charge is detected, recover and recharge the system adding the unit name plate charge.
6. Repair any damages to the line sets before proceeding.

Testing

TESTING CO₂ CIRCUIT FOR LEAKS

It is advisable to test the system for leaks before turning **ON** the water supply to the carbonator and connecting the syrup tanks. If a leak does exist, it will be easier and faster to make any correction.

1. Turn ON the CO₂ supply and adjust the primary regulator to 90 psi (6.2 bar)(620528.156099999906 Pascals).
2. Position the CO₂ tank changeover valve handle (if applicable) toward this regulator.
3. Move the air/CO₂ changeover valve to the CO₂ position (if applicable).
4. Allow the CO₂ gas to enter the system.

5. Wait for 2 or 3 minutes before turning OFF the CO₂ tank valve. This will allow the lines to expand under pressure.
6. Turn OFF the CO₂ tank valve. Observe the pressure on the high pressure gauge (not the 90 psi [6.2 bar] [620528.156099999906 Pascals] operating gauge). The needle may drop approximately 1 psi (.09 bar) (6894.75729 Pascals), but must remain constant and not lose pressure. Wait for several minutes.

If pressure continues to fall, this indicates there is a leak in the system which must be corrected.

The greater the leak, the faster the pressure will drop. The smaller the leak, the slower the gauge will drop.

It may be necessary to use a soap solution at all connections to locate a very small leak.

CO₂ gas must be present on all valves of the tower(s)

NOTE: All soap solution must be rinsed thoroughly from tubing upon completion of testing.

TESTING SYRUP CIRCUIT (5 GALLON TANKS ONLY)

Before connecting the syrup tanks to the system, the syrup circuits must be tested for leaks with CO₂ gas.

1. Connect an empty syrup tank to pre-mix syrup circuits.
2. Connect one of the CO₂ gas quick disconnects to this tank. Allow the tank to fill with CO₂ gas.
3. Observe the pressure of the primary CO₂ tank regulator (not the 90 psi [6.2 bar][620528.156099999906 Pascals]).
4. Allow the CO₂ tank pressure to remain ON for a few seconds. This will allow the lines to expand to operating conditions.
5. Turn OFF the CO₂ tank cylinder.
6. Check all connections from the syrup tank through the connections in the water bath area to all fittings at rear of tower.
7. Check syrup circuitry on the tower by activating the valve.
8. Follow the same procedure for the diet pre-mix beverage circuit.

If no leaks are found in the syrup circuits and the carbonated water circuit, the system is ready to be insulated and placed in operation.

Preparing Ice Bank

BUILDING AN ICE BANK

1. At this time, fill the unit water bath tank to the top, or within 1/2" (13 mm) of the top minimum, of the overflow tube. Use a garden hose or another water supply to do this.

NOTE: A manual fill valve is incorporated into the water circuit to the carbonator tank. This valve can be used to manually add water lost for any reason. Do not leave this valve ON constantly, only use it for filling and topping off. The water bath must be drained, flushed, and refilled every six months.

2. Main power to unit must be on. Power delay of 30 seconds occurs when power applied. "Pd30"
3. Press COMP/AGIT switch on keypad display.
4. Agitator will come on immediately and compressor delay will start. "Cd99" will count from 180 to 0.

NOTE: Turn this switch OFF to perform any operations in the water bath area.

With water bath water temperature of 65°F (18°C), ice must begin to form on the evaporator coils in approximately 2 hours. The unit will build a full ice bank in approximately 4 to 6 hours (depending on ambient water temperature).

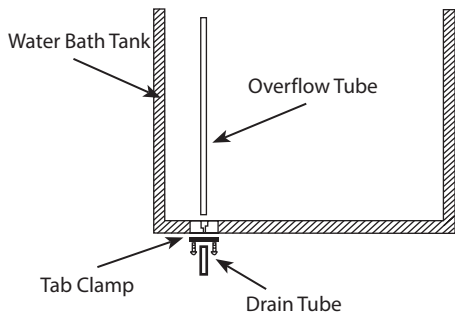

5. Turn on the main water supply to the booster assembly. Verify the booster is plugged in and that the accumulator tank valve is open. (If the system has an optional "Out-of-Syrup" device, verify that it is unplugged.)
6. Verify the pump is running. Place the valve on the right side of the pump box in the purge position until all air bubbles have passed through the line. Turn the valve back to "dispense". Plug the Out-of-Syrup device power cord into an appropriate wall outlet at this time (if supplied).

NOTE: Verify that the pump box holding tank is full before proceeding.

7. Turn on the circulator and carbonator. The carbonator must run for approximately 1 to 3 minutes and shut off. The circulator must run continuously. Verify that water is returning to the water bath through the return bulk head fitting.

Important

Wait until a thin layer of ice has begun to form on the evaporator before proceeding any further.

8. Go to the tower(s) and brix the valves. Using a syrup separator and volume cup, adjust the flow rate of the carbonated water to two fluid ounces per second. Then, using the separator and a brix cup, adjust the syrup flow rate for a ratio of carbonated water to syrup to 5 to 1.

Installation Checklist

- Check all fittings and conduit attachments for leaks.
- Check all insulated connections to make sure that they are sealed.
- Observe the pump operations for leaks.
- Check the water bath for full ice bank.
- The stabilized water bath operating temperature must be maintained at 33°F (0.6°C) to 35°F (1.7°C).
- Close water bath feeder valve completely.

Section 3 Operation

Typical System

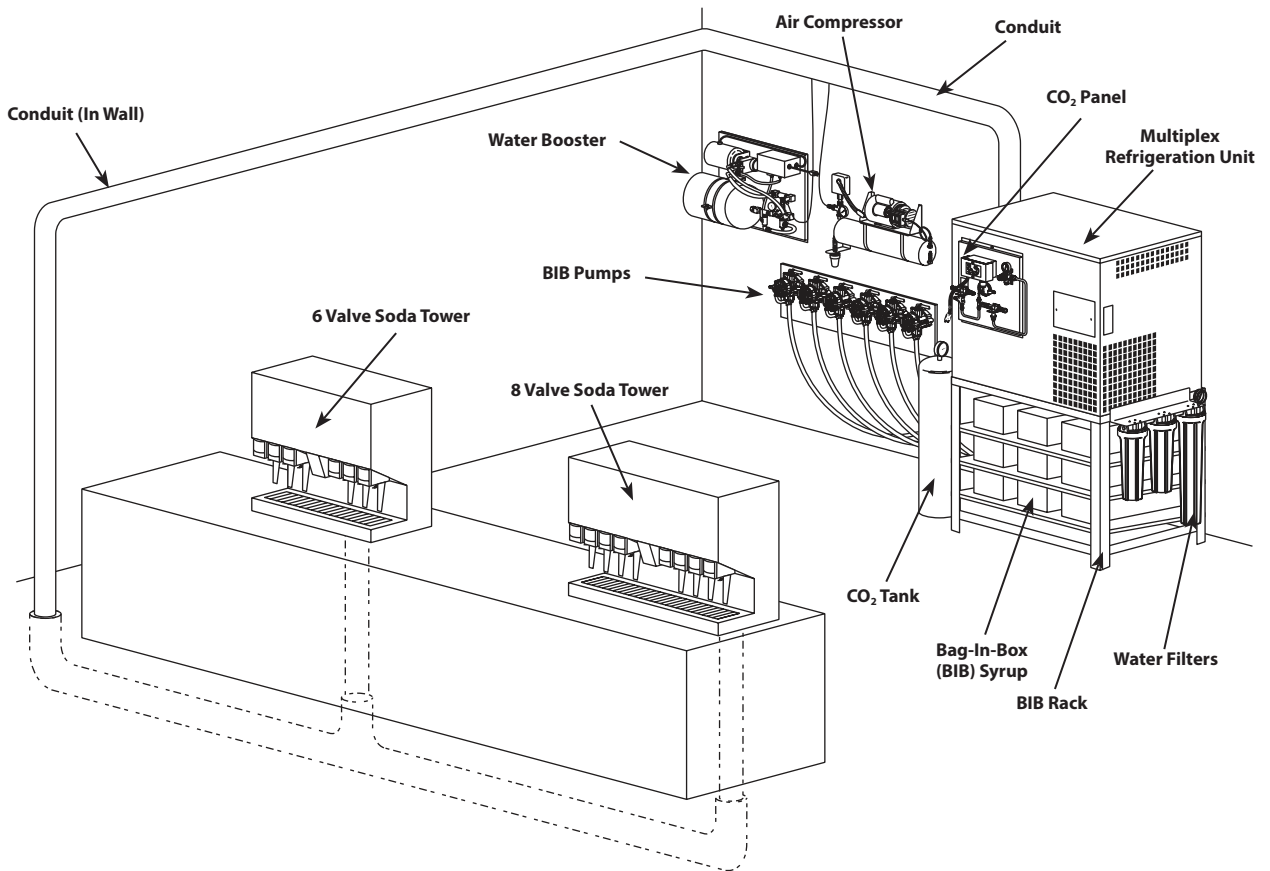

How the Multiplex Works

Multiplex Model 42 & 44

- 1 HP refrigeration unit
- Post-Mix carbonated beverages and chilled carbonated water: 21 gal (79 L) of syrup or carbonated water/day or 980 drinks/day (7,500 gal/yr)
- 250 ft (80 m) maximum conduit length

Super-Chil Model SC1000

- 1 HP refrigeration unit
- Chilled water: 29 gal (110 L) in 2 hrs (peak); 15 gal (57 L) in 2 hrs (sustained 24 hrs)
- 250 ft (80 m) maximum conduit length

These refrigeration units are remote refrigeration units that derive their peak capacity from the reserve ice bank. These systems are controlled to cycle ON and OFF by the operation of the ice control. The sensing probe that controls the ice bank is located on an adjustable bracket in the water bath.

Multiplex Model 50

- 2.2 HP refrigeration unit
- Post-Mix carbonated beverages and chilled carbonated water: 42 gal (159 L) of syrup or carbonated water/day or 2,000 drinks/day (15,000 gal/yr)
- 350 ft (107 m) maximum conduit length

Super-Chil Model SC2000

- 2.2 HP refrigeration unit
- Chilled water: 55 gal (208 L) in 2 hrs (peak); 30 gal (114 L) in 2 hrs (sustained 24 hrs)
- 350 ft (107 m) maximum conduit length

These refrigeration units are remote refrigeration units that derive their peak capacity from the reserve ice bank produced by the operation of the compressor. These systems are controlled to cycle ON and OFF by the operation of the ice bank control. The sensing probe that controls the ice bank is located on an adjustable bracket in the water bath.

Start-Up

PLACING EQUIPMENT IN OPERATION

Before placing equipment in operation, verify that all requirements for roof mounted Remote Condenser units (if applicable) have been satisfied. Refer to the instructions on installing the Remote Condenser. Verify proper supply power to unit.

1. Fill the refrigeration unit water bath tank with water to within 1/2" (13 mm) of the top of the overflow tube.
2. Open the manual water shut-off valve to the water cooled condenser (if applicable). Refer to page 3-3 for control programming sequence.
3. Press "Comp/Agit" to begin building an ice bank.
4. Ice will begin to form on the evaporator coils in approximately 2 hours.
5. The refrigeration unit will build an ice bank in approximately 4 to 6 hours.
6. If optional CO₂/Water Control Panel has been installed on the refrigeration unit, refer to the installation instructions for operation and testing the circuits for leaks.
7. The carbonation circuits "A" and "B," as well as the syrup circuits must be checked for leaks and possible cross circuits before turning ON the water supply to carbonator pumps.
8. Turn on main water supply. Set incoming regulator to 55 psi on the CO₂/Water control panel. Once water is supplied to the unit, air needs to be purged from the carbonator tank. Do so by lifting press relief valve tab until water comes out of relief valve.
9. Set bag-in-box syrup tank push pressure CO₂ regulator to 60 psi.

PLACING THE SYRUP SYSTEM IN OPERATION

1. Open the CO₂ gas supply valve at CO₂ tanks or bulk tank. Adjust the CO₂ pressure to 90 psi (6.2 bar).
2. Open relief valve on top of the carbonator tank for 4 seconds to bleed off air in tank.
3. Verify the water supply to unit is on.
4. Press the switch labeled "Carb A" (and "Carb B" if applicable). Allow carbonator to run and cycle OFF.
5. Press the switch labeled "CIRC A" (and "CIRC B" if applicable).
6. Activate all valves until a smooth, continuous flow or carbonated water and non-carbonated water appear at the valves.
7. Allow at least 1 hour before proceeding to calibration instructions. You may complete the sanitizing instructions during this period.

Sequence of Operation

ELECTRONIC CONTROL

Prerequisites

- Potable water must be connected to the carbonator pump circuit.
- The ice bank water bath water must cover the evaporator. The compressor will not start unless the ice bank control probes are immersed in water.
- CO₂ must be supplied.

Initial Power-up

The control has a 30-second delay when power is connected, or disconnected and reconnected. The display will show Pd30 - power delay and 30 seconds left in the countdown cycle.

Normal Operation

NOTE: This sequence of operation includes systems with up to two recirculation/carbonation circuits. Your model may not employ a second circuit or second carbonation pump.

Pressing the COMP/AGIT button will start the water bath agitator immediately and initiate the 180 second compressor delay. The display will show Cd99 (compressor delay & 99 seconds) and will start to count down from 99 seconds after the first 81 seconds have elapsed. After 180 seconds the compressor and condenser fan motor energize and the COMP/AGIT LED flashes. Pressing the CARB A and CARB B buttons will power the carbonator tank liquid level control. The corresponding LED flashes to indicate the pump is running. Pressing the CIRC A & CIRC B buttons will immediately energize the circulating pumps and energize the LED constantly. The display will show the circulating temperature and show the A circuit. When two circuits are used, the readout will alternate between A and B circuits every 5 seconds.

The compressor and condenser fan will continue to run until ice contacts the ice bank control probe closest to the evaporator. When ice contacts the probe, the COMP/AGIT LED lights constantly and the compressor and condenser fan motor de-energize.

As the ice bank melts, the ice bank control probe will lose contact with the ice; the LED will flash and the compressor and condenser fan motor will restart. This cycle will repeat as required depending on load.

Power Interruption

During a power interruption the control will resume from the point of interruption when power is reapplied and the time delay expires. Any switches/components that were energized when power was interrupted will be energized when power is reapplied.

Error Codes

- E1 = Low Water Supply Pressure
- E2 = Low CO₂ Pressure
- E3 = Low Water Level - Water Bath
- E4 = High Water Bath Temperature
- E5 = High Water Supply Pressure
- E6 = High Refrigeration Temperature
- E7 = High Ice Bank Size (Probe Sensor 2)
- E8 = Long Carb A Run Time
- E9 = Long Carb B Run Time

NOTE: Shorted Transducer = "----"

Open Transducer = "===="

Error codes will display until corrected.

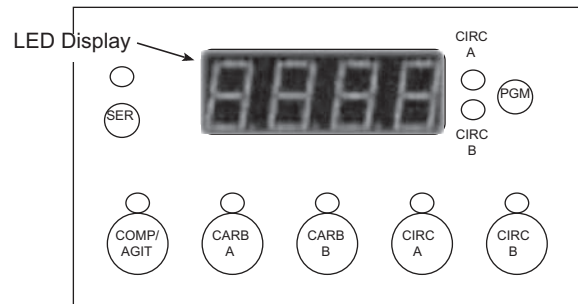

Control Programming

There are 5 programming modes:

1. Used to check probes, water bath level, set unit of measure, & check temperatures.
2. Add additional (third or fourth) circulation pumps
3. For Beermaster Units only - Sets water/glycol temperature.
4. Temporarily cancel display of error codes.
5. Energy Saving Mode. (G Series Models)

SER Switch

- For when optional LON communication network is connected.

PGM Switch

- Used to enter and exit programming modes. To enter, press and hold switch for 3 seconds, repeat to exit.
 - Press and hold Carb B switch — Display will indicate **CO₂ Pressure**

PROGRAM MODE 1

To enter, press and hold switch for 3 seconds.

- **0001** will display indicating Mode 1
- Wait 3 seconds **C000** will display
- Press and hold **Carb A** switch — Display will indicate one of the following:
 - **CA00** — Low and High Probes are open (carbonator motor is energized)
 - **CA11** — Low and High Probes are closed (carbonator motor is de-energized)
 - **CA01** — Low Probe closed (Motor will still be on)
- Press and hold **Carb B** switch — Display will indicate one of the following:
 - **Cb00** — Low and High Probes are open (carbonator motor is energized)
 - **Cb11** — Low and High Probes are closed (carbonator motor is de-energized)
 - **Cb01** — Low Probe closed (Motor will still be on)
- Press and hold **COMP/AGIT** switch — Display will indicate one of the following:
 - **CL 0** — Water level low
 - **CL 1** — Water level OK
- Press **PGM** Switch 1 time — **F000** will display:
 - Press **COMP/AGIT** to toggle between **F000** (Fahrenheit) and **FC00** (Centigrade)
 - Press and hold **Carb A** switch — Display will indicate **Water Bath Temperature**
 - Press and hold **Circ A** switch — Display will indicate **Liquid Line Temperature**
 - Press and hold **Circ B** switch — Display will indicate **Suction Temperature**
- Press **PGM** Switch twice or a second time — **P000** will display
 - Press and hold **Carb A** switch — Display will indicate **Water Pressure**

PROGRAM MODE 2

Add circulation pumps C and/or D.

- Press **PGM** button for 3 seconds - Display shows **0001**.
- Press **PGM** button again in less than 3 seconds - Display shows **0002** program mode 2.
- Wait 3 seconds - Display shows **-002** = Factory default setting.
 - Pressing **CIRC A** button energizes/de-energizes pump A
 - Pressing **CIRC B** button energizes/de-energizes pump B
- Program CIRC C - Press **CARB A** button - Display shows **-102** = **Carb A** button energizes/de-energizes pump C
- Program CIRC D - Press **CARB B** button - Display shows **-012** = **Carb B** button energizes/de-energizes pump D
- Four pumps shows **-112**.

NOTE: CIRC C motor needs to be connected to CARB A output connection on the ERC board & CIRC D motor to CARB B output connection.

Press and hold **PGM** switch for 3 seconds to save settings and exit program mode.

PROGRAM MODE 3

This mode is for Beermaster units only and not used on Soda or Water refrigeration systems. To turn this mode **ON/OFF** do the following;

- Press **PGM** button for 3 seconds - Display shows **0001**.
- Press **PGM** button twice in less than 3 seconds to enter program mode 3 - Display shows **0003**
- Wait 3 seconds, display shows **-003**
- Press the **COMP/AGIT** button once to toggle to BEER MODE.
 - **BEER MODE ON** = Display shows **1273**
 - **BEER MODE OFF** = Display shows **1- -3**

 **Caution**

If BEER MODE is ON, the water bath will be set to 27°F factory default temperature setpoint and freeze. Do not place Soda or Water refrigeration units in BEER MODE.

- Press and hold **PGM** switch for 3 seconds to save settings and exit program mode.

PROGRAM MODE 4

Temporarily cancel display of error codes. Cancelling the error codes allows circulating glycol temperatures to be displayed until the error can be corrected.

- Press **PGM** button for 3 seconds - Display shows **0001**.
- Press **PGM** button three times in less than 3 seconds - Display shows **0004** program mode 4.
- Wait 3 seconds - Display shows **-004** = All error codes will be displayed during run mode (Factory Default).
- Press **COMP/AGIT** button once - Display shows **---4** = error codes will not be displayed during run mode.

NOTE: Disconnecting and reconnecting main power will reset the control board to the factory setting **-004** = Error codes will be displayed in the run mode.

- Press and hold **PGM** switch for 3 seconds to save settings and exit program mode.

PROGRAM MODE 5 (G SERIES MODELS)

Energy-Saving Program Mode

ERC Control (020001985) - Must be Hardware version 4.0 or greater, Software version 3.19 or greater.

- Press **PGM** button for 3 seconds - Display shows **0001**.
- Press **PGM** button four times in less than 3 seconds - Display shows **0005** program mode 5.

NOTE: If **0005** fails to display, you have an incompatible version of the ERC control board and this mode is not available.

- Wait 3 seconds or until the display shows **-X-5**
- Press **COMP/AGIT** button to enable/disable energy savings mode.
 - A. **-o-5** = Energy savings mode enabled
 - B. **---5** = Energy savings mode disabled
- Press and hold **PGM** switch for 3 seconds to save settings and exit program mode. All changes permanently saved and display will revert back to normal run mode

ERC Operation in Mode 5

Circulating motor LED will flash once per second if energy saving PGM mode 5 is enabled. The LED will stay constantly ON if energy saving PGM mode 5 is disabled.

ERC control monitors all carb motors for entering energy savings cycle mode. If no carb cycles in 30 minutes, no ERC error codes or sensors open / shorted, and circulating temperature = < 3.3°C (38°F), then energy savings cycle mode will be entered.

NOTE: Display adds "o" to left digit to indicate in energy savings cycle mode "oxxc" (Centigrade) "oxxF" (Fahrenheit)

1. If circ temp = <2.2°C (36°F), energy savings cycle mode off time is 10 minutes.
2. If circ temp = <2.8°C (37°F) and >2.2°C (36°F), energy savings cycle mode off time is 8 minutes.
3. If circ temp = <3.3°C (38°F) and >2.8°C (37°F), energy savings cycle mode off time is 6 minutes.
4. If circ temp = >3.3°C (38°F), then no energy savings cycle mode entered.

Agitator and circulator will be turned off when in energy savings cycle mode off-time.

When energy savings cycle mode off-time is completed, agitator and circulator motors will be turned on in energy savings cycle mode on-time.

Motors will stay on until temperature entered is reached: (<2.2°C (<36°F), >2.2-2.8°C (36-37°F), >2.8-3.3°C (37-38°F))

Energy savings cycle mode will repeat (off time 10, 8, 6 minutes depending on entering temperature, then on again until entering temperature is reached).

Energy savings cycle mode is exited when:

- Any carb cycle occurs
- Any error code occurs
- Circulating temperature exceeds 3.3°C (38°F)

Display changes to normal run mode, and circulating LED flashes for controlled ON. System waits for another 30 minute period without carb cycle to enter energy savings cycle mode again.

Equipment Setup & Close Procedure

EQUIPMENT SETUP PROCEDURE

1. Ensure that all valve nozzles are attached to the valves.
2. Observe pressure of CO₂ high pressure tank of 500 psi (34 bar) or more, or bulk CO₂ tank of 150 psi or more. Primary regulator set at 90 psi (6 bar) and the secondary regulator set at 35 psi (2.4 bar).
3. Observe the control panel to verify that all pressure gauges are set at correct operating pressures.
4. Check the syrup tanks to make sure a sufficient number of tanks are connected in series to satisfy business volume.
5. Clean syrup inlet and outlet quick disconnects at the same time tanks are replaced. Rinse disconnects in clean potable water.

EQUIPMENT CLOSE PROCEDURE

1. Clean the underside of the dispensing tower around the nozzle area with a clean damp towel.
2. Pour at least 60 oz (1.8 liters) of warm water down the drain openings.

ERC Programming Flowchart - Modes 1-4

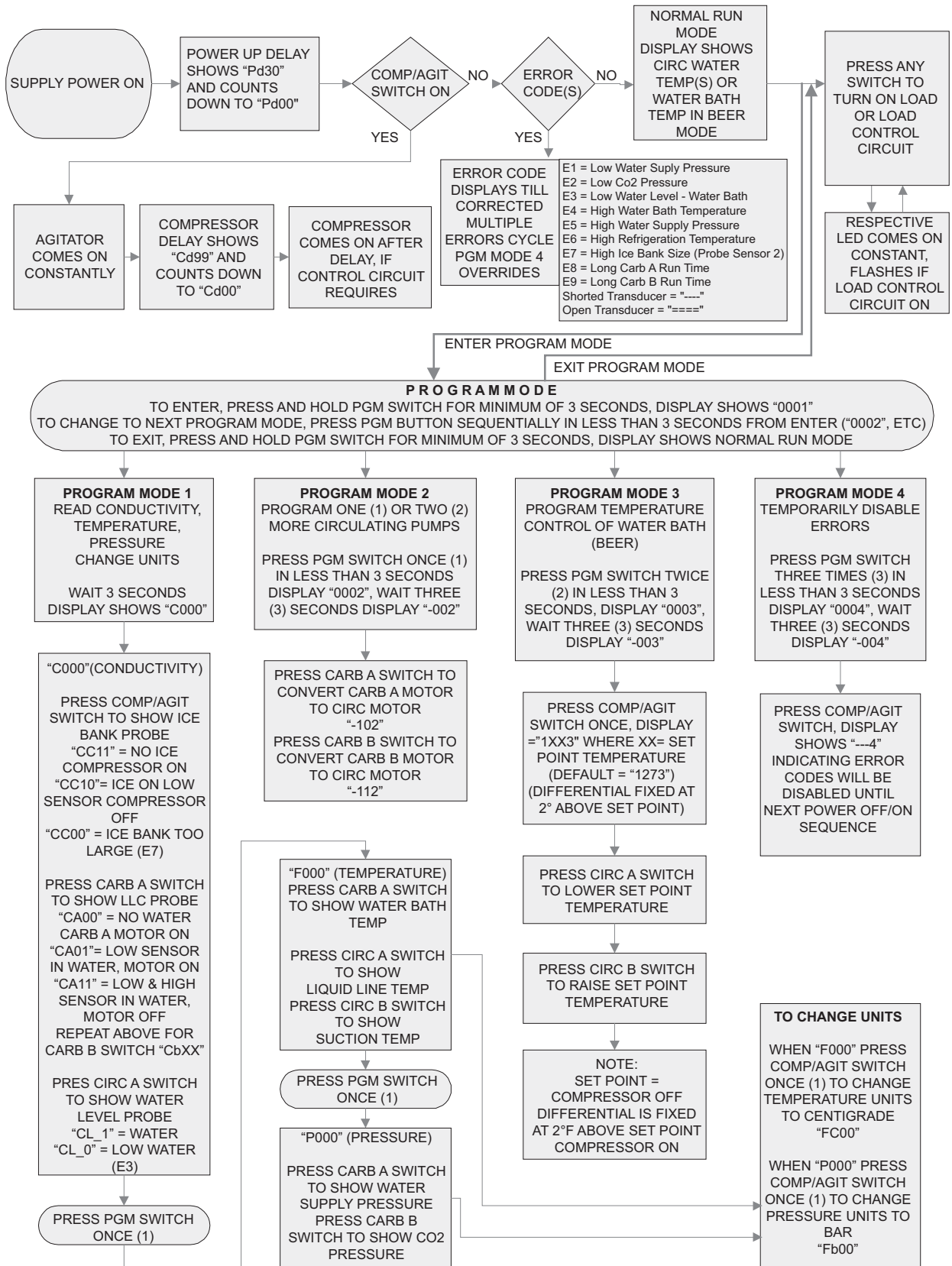

ERC Programming Flowchart - Mode 5

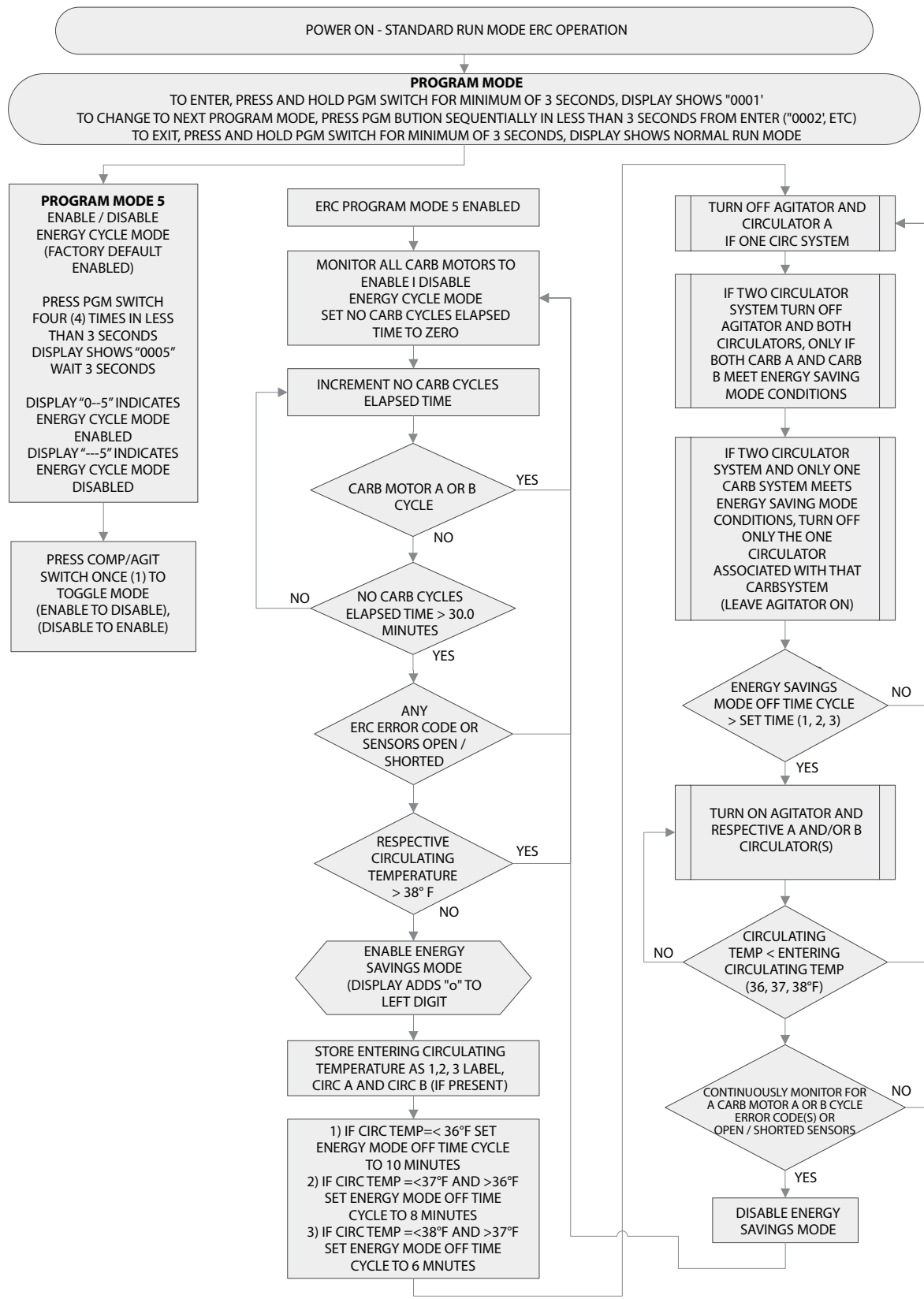

Section 4

Maintenance

Maintenance Schedule

This section provides a list of periodic maintenance tasks and the scheduled frequency required to ensure the proper operation of your Multiplex dispensing equipment. To ensure quality beverages, prevent downtime, and reduce costs, these tasks must be performed as indicated.

PERIODIC MAINTENANCE FOR EQUIPMENT (LISTED BY MAJOR COMPONENTS)

Dispensing stations

Daily (365 times per year)

- Take temperature of finished drinks. Pour off the first and take the temperature of the second drink. The proper temperature of drinks must be 40°F (4°C) or less.
- Remove nozzles and diffusers and soak in mild detergent cleaning solution. Scrub parts with small bristle brush taking care to clean small crevices and O-ring grooves. Turn OFF power to dispensing valves. Scrub exterior surfaces, including bottom splash area and actuator lever, with cleaning solution. Reassemble diffusers and nozzles. Wipe dry exterior surfaces before turning ON power.
- Flush all dispenser drains. Pour warm water down drains at closing.

Beverage conduits

Every 3 months (4 times per year)

- Inspect beverage conduits for damage. Re-insulate and seal any un-insulated areas.
- Inspect floor chases and seal any open chase ends.

Air compressor

Monthly (12 times per year)

- Drain condensate water from air compressor tank.

Every 4 months (3 times per year)

- Inspect air compressor filter and replace if clogged. Air filter must be replaced every 6 months.
- Inspect air compressor to verify cut-in at 70 psi (4.8 bar) and cut-out at 90 psi (6.3 bar). Adjust pressure switch if necessary.
- Inspect system for air leaks and repair as required.

Refrigeration unit

Every 4 months (3 times per year)

- Clean the refrigeration unit air-cooled condenser using a vacuum cleaner or soft bristle brush. If equipped with water-cooled condenser, verify the water discharge temperature is at 105°F (41°C). Adjust water modulating valve if necessary.
- Inspect water bath to verify water level is at the top of stand pipe. If below, add water and repair water makeup device. If excessive amount of water is flowing over stand pipe, locate leak within bath and repair.
- Inspect ice bank within the water bath to verify proper size ice bank and clarity. Look for uniform, 2" to 4" thick ice bank.
- Drain, clean, and refill water bath.
- Inspect agitator motor and ensure proper operation.
- Inspect the circulating motor/pump assembly, oil motor.
- Inspect the carbonating motor/pump assembly. Clean strainer and oil motor.
- Inspect entire system for leaks and repair as required.

Water filters

Every 4 months (3 times per year)

- Verify that incoming water pressure is not less than 40 psi (2.8 bar) or greater than 60 psi (4.1 bar). If equipped with a water regulator, verify proper setting of 55 psi (3.8 bar). Adjust if necessary.
- If pressure is low, inspect water filter cartridges to ensure they are able to supply adequate water pressure under normal system flow. Replace if unable to provide minimum 20 psi (1.4 bar) under load.

Syrup supply

Daily (365 times per year)

- Clean general area of syrup hookup with soap and warm water. Rinse off all soap.

Every 4 months (3 times per year)

- Inspect syrup lines for proper flavor identification labels. Replace labels if necessary.
- Disconnect syrup containers. Clean connector with soap and warm water. Rinse with plain water and reconnect to syrup containers.

CO₂ gas supply

Every 4 months (3 times per year)

- Inspect pressure setting at CO₂ high pressure regulator. Verify proper 90 psi (6.3 bar) pressure setting. Adjust if necessary.
- Inspect pressure setting at syrup pressure regulators. Verify proper pressure setting. Adjust if necessary.
- Inspect system for CO₂ leaks, repair as required.

CLEANING AND SANITIZING THE DISPENSING VALVES AND PRODUCT LINES

Maintenance Schedule

Every day	
Dispensing valves	Remove nozzles and diffusers and soak in mild detergent cleaning solution. Scrub parts with small bristle brush taking care to clean small crevices and O-ring grooves. Turn OFF power to dispensing valves. Scrub exterior surfaces, including bottom splash area and actuator lever, with cleaning solution. Reassemble diffusers and nozzles. Wipe dry exterior surfaces before turning ON power.
Drip pan and drain hose	Wash with mild detergent. Rinse with warm clean water.
Quick disconnects	Wash with mild detergent. Rinse with potable water.
Weekly	
Outside, dispenser cabinet	Wash with clean water and mild detergent. Wipe dry.
Every 3 months	
Syrup circuits	Sanitize each syrup circuit. See "Sanitizing".
Water bath	Drain, melt ice and clean using detergent and brush; rinse with potable water. Do not use water over 140°F (60°C).
Every 6 months	
Condenser	Vacuum fins or use soft bristle brush (scrub brush).
Air compressor filter (if equipped)	Replace.

Cleaning Equipment and Supplies

- **Recommended cleaner:** Any caustic-base (low sudsing, non-perfumed, easily rinsed) detergent solution which provides a minimum 2% sodium hydroxide. The solution must be prepared in accordance with the manufacturer's instructions. Solution temperature must be between 90°F (32°C) and 110°F (43°C). Temperatures in excess of this can cause internal damage to the dispensing valve components.
- Recommended sanitizer: Any sanitizer which provides a minimum of 120 parts per million (120 milligrams per liter) of available chlorine. Solution temperature must be between 90°F (32°C) and 110°F (43°C). Temperatures in excess of this can cause internal damage to the dispensing valve components.
- **Two five gallon (figals) syrup tanks** and fittings, cleaned and sanitized (one for cleaner; one for sanitizer)
- **Containers** for cleaner and sanitizer solutions
- **Clean, non-abrasive cloths**
- **Buckets**
- **Small Brush**
- **Extra Nozzles**

Sanitizing

BEVERAGE SYSTEM CLEANING

⚠ Warning

Flush sanitizing solution from syrup system.

Residual sanitizing solution left in system could create a health hazard.

⚠ Warning

When using cleaning fluids or chemicals, rubber gloves and eye protection must be worn.

Sanitize the beverage system at initial start-up as well as regularly scheduled cleaning. The drain pan must be in place under soda valves, to carry away detergent and sanitizing agents that will be flushed through valves.

BAG-IN-BOX SYSTEM SANITATION

The procedure below is for the sanitation of one syrup circuit at a time. Repeat to sanitize additional circuits.

You will need the following items to clean and sanitize the Bag-in-Box (BIB) beverage system:

- Three (3) clean buckets
 - Plastic brush or soft cloth
 - Mild detergent
 - Unscented bleach (5% Na CL O) or Commercial sanitizer
 - Bag-In-Box bag connector
1. Prepare the following in the buckets:
 - Bucket 1 — warm, not too hot, tap water for rinsing.
 - Bucket 2 — mild detergent and warm, not too hot, water.
 - Bucket 3 — mix a solution of unscented bleach (5% Na CL O) or commercial sanitizer and warm, not too hot, water. Mixture should supply 100 PPM available chlorine (1/4 oz. bleach to 1 gallon water).

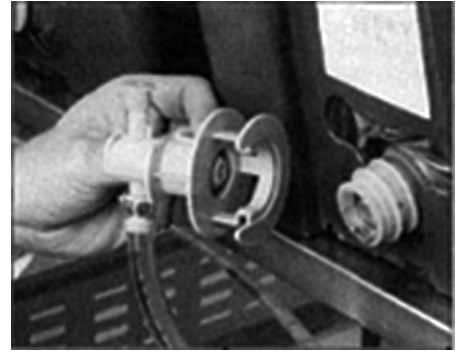

2. Disconnect the “syrup-line side” of the BIB connector.

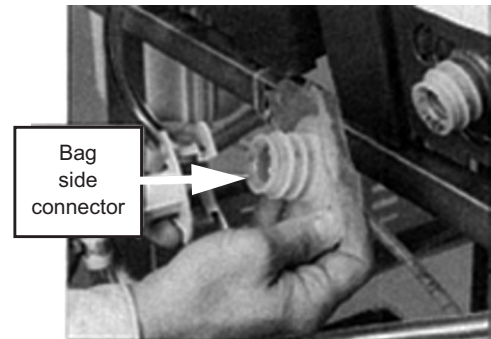

3. Rinse connector with warm tap water.

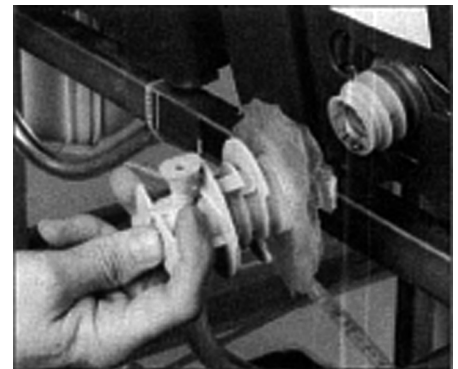

4. Connect syrup connector to BIB connector and immerse both into Bucket 1. A “bag-side” connector can be created by cutting the connector from an empty disposable syrup bag.

5. Draw rinse water through system until clean water is dispensed. Most beverage valves allow the syrup side to be manually activated by depressing the syrup pallet.
6. Connect Bucket 2 to system.
7. Draw detergent solution through system until solution is dispensed.
8. Repeat steps 2-7 until all syrup circuits contain detergent solution.
9. Allow detergent solution to remain in the system for 5 minutes.
10. Connect Bucket 3 to system.
11. Draw sanitizing solution through system until solution is dispensed.
12. Repeat step 11 until all syrup circuits contain sanitizer solution.
13. Allow sanitizer solution to remain in system for 15 minutes.
14. Remove nozzles and diffusers from beverage valves.
15. Scrub nozzles, diffusers and all removable valve parts (except electrical parts) with a plastic brush or a soft cloth and the detergent solution.
16. Soak nozzles, diffusers and removable valve parts (except electrical parts) in sanitizer for 15 minutes.
17. Replace nozzles, diffusers and valve parts.
18. Connect Bucket 1 to system.
19. Draw rinse water through system until no presence of sanitizer is detected.
20. Attach syrup connectors to BIBs.
21. Draw syrup through the lines to rinse the system. Discard drinks until at least two cups of satisfactory tasting beverage are dispensed through the valve.

FIGAL BEVERAGE SYSTEM

1. Prepare the following in three clean Figal tanks:
 - **Rinse tank** - fill with warm tap water.
 - **Detergent tank** - mix approved beverage system cleaner with warm water as directed.
 - **Sanitizing tank** - mix a solution of unscented bleach (5% Na CL O) or commercial sanitizer and warm to hot water. Mixture should supply 100 PPM available chlorine (1/4 oz. bleach to 1 gallon water).
2. Disconnect all product and water lines from product tanks and remove carbonator.
3. Locate the Figal syrup tank for the circuit to be sanitized. Remove both quick disconnects from the Figal syrup tank. Rinse quick disconnects in tap water.
4. Connect rinse tank to the syrup line. Draw clean rinse water through the valve until syrup is flushed from the system.
5. Connect detergent tank to the syrup line and draw detergent through the valve for two minutes. Then, allow remaining detergent to stay in the system for five minutes.
6. Connect rinse tank to the syrup line. Draw clean rinse water through the valve until detergent is flushed from the system.
7. Remove valve nozzle and diffuser as shown in Daily Cleaning instructions. Using a plastic brush or a soft cloth and warm water, scrub the nozzle, diffuser, bottom of the dispensing valve and cup lever, if applicable.
8. Place removable valve parts (EXCEPT solenoids) in sanitizing solution for 15 minutes.
9. Replace valve diffuser and nozzle on the beverage valve.
10. Connect sanitizer tank to the syrup line and draw sanitizer through the valve for two minutes. Allow sanitizer to remain in the system for a minimum of 15 minutes.
11. Reconnect syrup and carbonated water lines.
12. Draw syrup through the lines to rinse the system. Discard drinks until at least two cups of satisfactory tasting beverage are dispensed through the valve.

Back-Flow Preventer Maintenance

The integral carbonator in this unit is equipped with a back-flow preventer designed to protect the potable water supply from CO₂ contamination.

Important

The back-flow preventer must be checked at least once every year to confirm that it is functioning properly.

1. Shut OFF power to unit.
2. Shut OFF potable water supply to unit. Do not shut OFF CO₂ supply.
3. Remove top cover panel of unit and disconnect inlet fitting from back-flow preventer.
4. The carbonator tank is still pressurized.
5. Observe inlet of back-flow preventer #1 check for any discharge. If there is no discharge, #1 check is OK. Proceed to step 5. If there is discharge, proceed to step 6.
6. Observe inlet of #2 check for any discharge. If there is no discharge, #2 check is OK. Proceed to step 7. If there is discharge, proceed to step 6.
7. Shut OFF CO₂ supply and relieve pressure from carbonator tank.
8. Remove back-flow preventer and install new back-flow preventer. Turn ON CO₂ supply and check for leaks.
9. Check water supply strainer upstream of back-flow preventer. Clean out and/or replace as required.
10. Reconnect water lines and turn water supply ON.
11. Turn ON power to unit.

Shipping, Storage and Relocation

Caution

Before shipping, storing, or relocating this unit, syrup systems must be sanitized. After sanitizing, all liquids (sanitizing solution and water) must be purged from the unit. A freezing environment causes residual sanitizing solution or water remaining inside the unit to freeze, resulting in damage to internal components.

THIS PAGE INTENTIONALLY LEFT BLANK

Section 5 Troubleshooting

Checklist

If a problem arises during operation of your post mix soda refrigeration unit, follow the checklist below before calling service. Routine adjustments and maintenance procedures are not covered by the warranty.

⚠ Warning

Only trained and certified electrical and plumbing technicians must service this unit. All wiring and plumbing must conform to national and local codes.

Problem	Possible Cause	To Correct
Water only dispensing: No pressure	Regulator(s) out of adjustment	Check/adjust regulator(s).
	Out of CO ₂	Install fresh tank.
	Defective regulator(s)	Check/repair/replace regulator(s).
	CO ₂ line pinched, kinked, or obstructed	Check/repair/replace CO ₂ line.
Syrup and CO ₂ only dispensing: Carbonator	No power	Check power supply. Plug in carbonator or reset breaker.
	Water supply	Make sure water is turned ON.
		Replace water filter.
		Check/clean/replace pump strainer.
		Check/clean/repair water check valve.
Check for frozen water line. Internal Carbonator unit only.		
Defective carbonator	Check/repair/replace carbonator pump, motor, electrode or liquid level control.	
Syrup and plain water only dispensing: No pressure	Out of CO ₂	Install fresh tank.
	HP regulator out of adjustment	Adjust HP regulator to the proper setting.
	Defective HP regulator	Check/repair/replace HP regulator.
	CO ₂ line pinched, kinked, or obstructed	Check/repair/replace CO ₂ line.
One valve will not dispense anything: Is there power to the valve?	Broken wire or loose connection	Replace/repair wire or connector.
	Bad microswitch	Replace microswitch.
Beverage dispensed is too sweet: Is the ratio (brix) of the drink correct?	Flow control out of adjustment	Adjust the flow control.
	Insufficient soda flow due to low carbonator pressure	Adjust CO ₂ pressure or change the tank.
	Low CO ₂ pressure due to leaks	Repair CO ₂ leaks.
	Obstruction in the water or soda line	Clean out the lines.
Beverage is not sweet enough: Is the ratio (brix) of the drink correct?	Flow control out of adjustment	Adjust the flow control.
	Soda flow too high	Reset CO ₂ pressure or replace regulator if necessary.
	Obstruction in syrup line	Clean out the syrup line.
Drinks are foaming: Are system pressures correct?	Over carbonation	Check CO ₂ supply. Reset pressure or replace regulator as necessary.
	Dirty lines/valves	Clean and sanitize entire system.

Error Notes

- Error codes will interrupt the temperature display and stay active until the error is corrected.
- If multiple errors are present, the errors will rotate and display every 5 seconds.

- Resetting errors — After correcting the problem, the respective switch for the error must be cycled OFF and then ON to reset.
- Disconnecting and reconnecting power will erase all errors.

Error Code	Error	Cause
E1	Low Water Supply Pressure	Lower than 5 psi for 5 Seconds
E2	Low CO ₂ Pressure	Lower than 10 psi for 5 Seconds
E3	Low Water Level – Water Bath	Must Cover Top of Evaporator - Water Level Probe Mounted Too High
E4	High Water Bath Temperature	Water Bath Temperature Greater Than 45°F
E5	High Water Supply Pressure	Water Pressure Greater than 75 psi
E6	High Refrigeration Temperature	Discharge Line Temperature Greater than 190°F
E7	High Ice Bank Size	Ice Contacting Center Ice Bank Probe
E8	Long Carb A Run Time	Energized for 7 Continuous Minutes
E9	Long Carb B Run Time	Energized for 7 Continuous Minutes

E1, E2, & E3 Flowchart

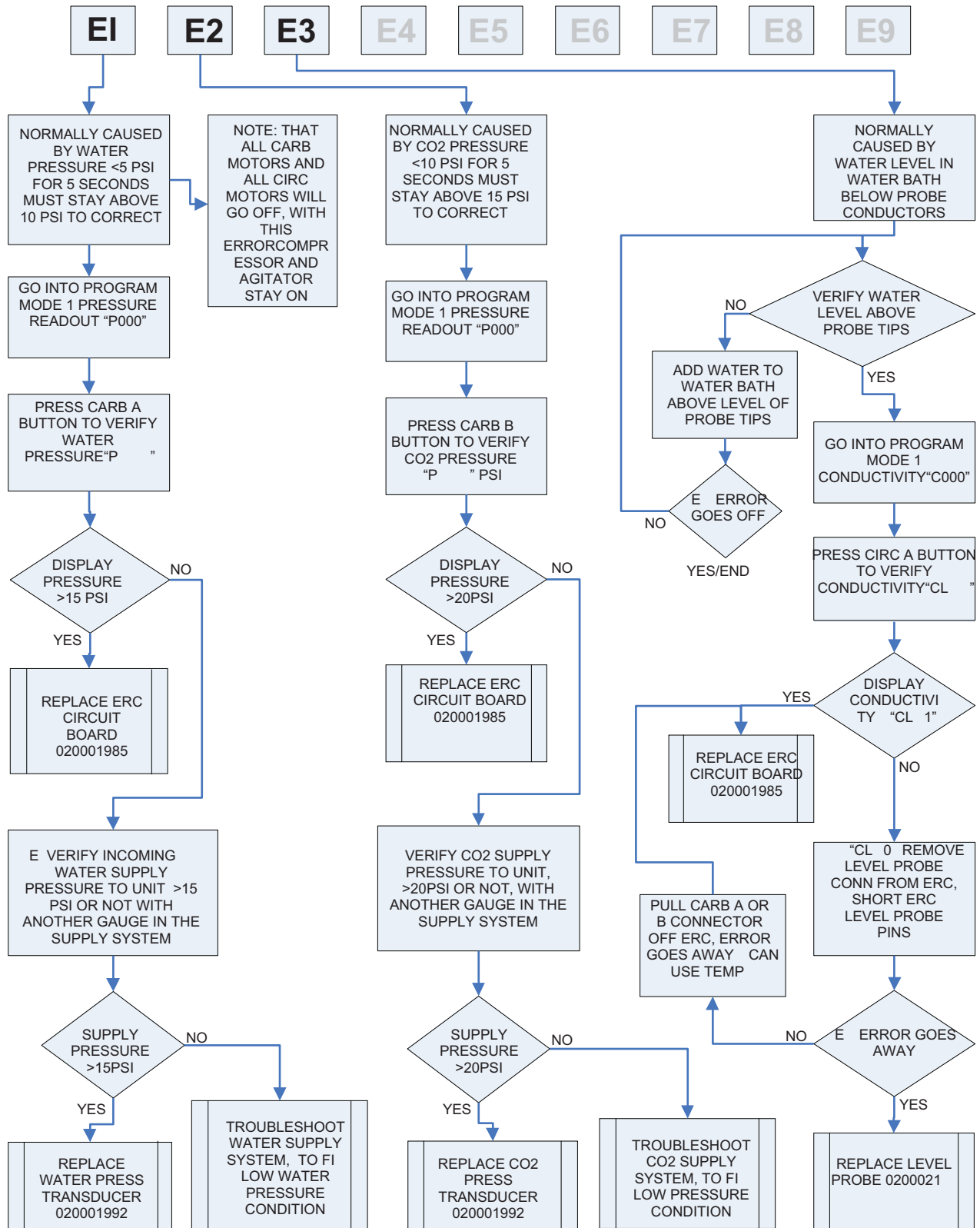

E4, E5, & E6 Flowchart

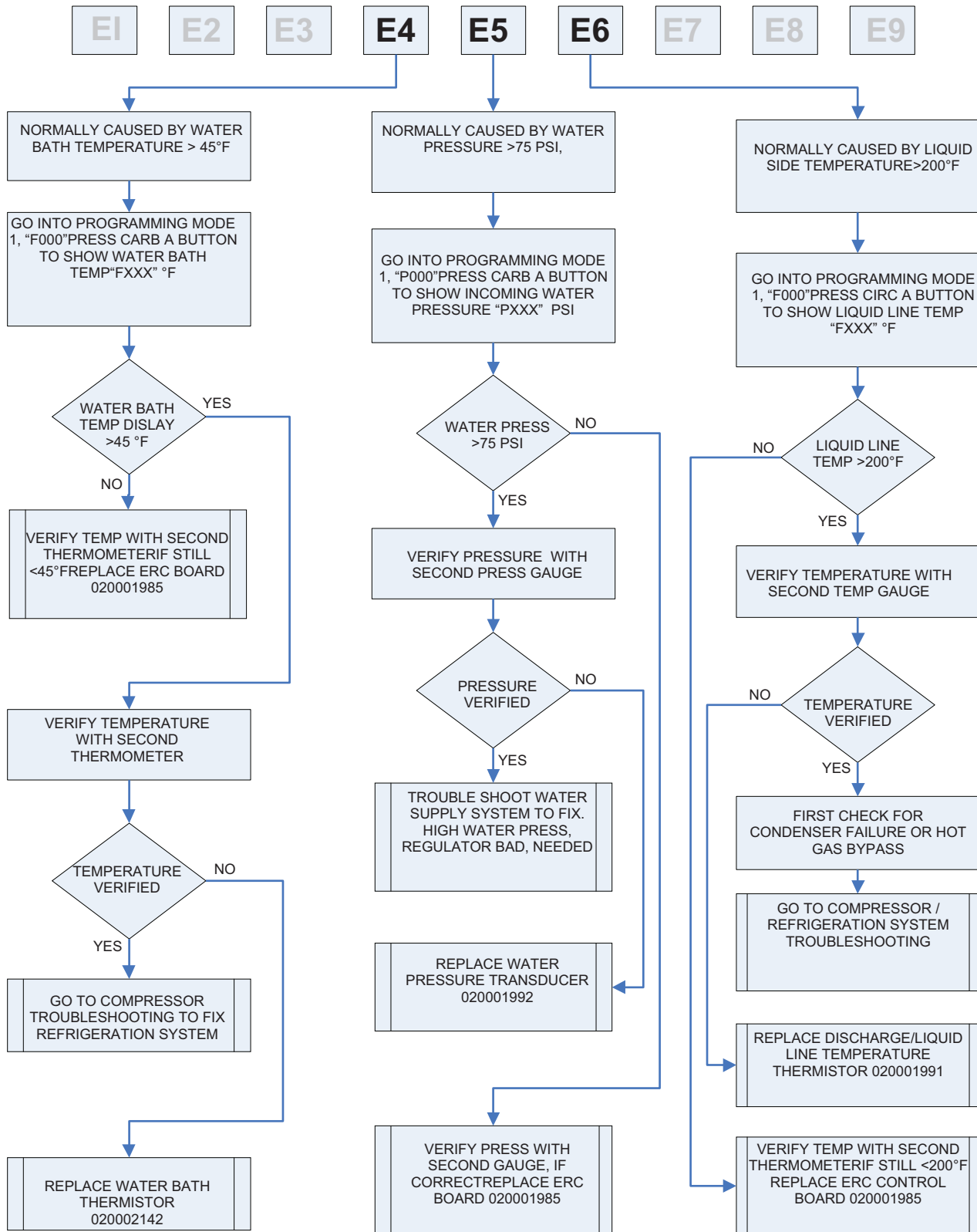

E7, E8, & E9 Flowchart

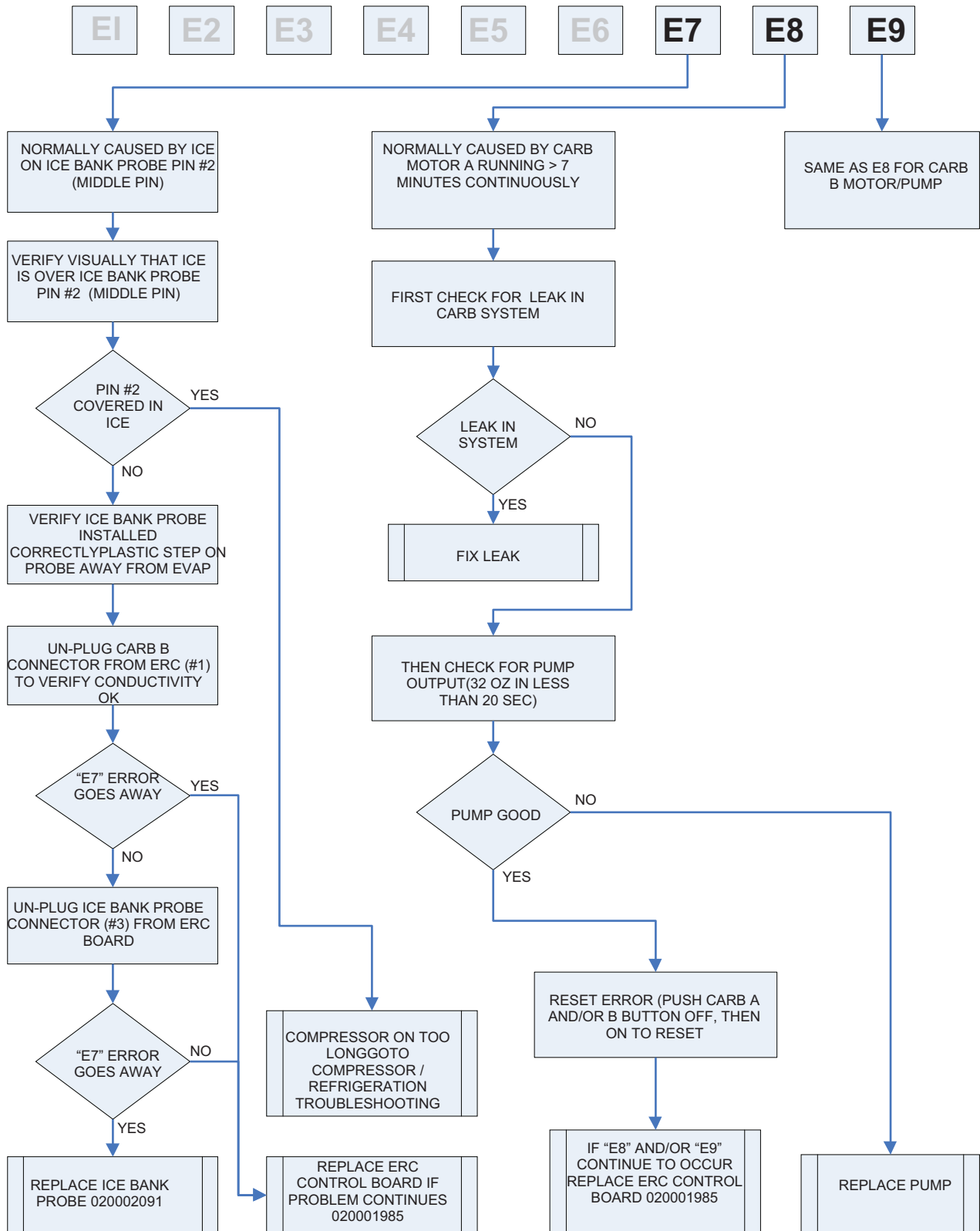

THIS PAGE INTENTIONALLY LEFT BLANK

THIS PAGE INTENTIONALLY LEFT BLANK



MULTIPLEX
2100 FUTURE, SELLERSBURG, IN 47172

800-367-4233
WWW.MANITOWOCBEVERAGE.COM/US

Every new piece of Manitowoc Foodservice equipment comes with KitchenCare™ and you choose the level of service that meets your operational needs from one restaurant to multiple locations.

StarCare – Warranty & lifetime service, certified OEM parts, global parts inventory, performance audited

ExtraCare – CareCode, 24/7 Support, online/mobile product information

LifeCare – Install & equipment orientation, planned maintenance, KitchenConnect™, MenuConnect

Talk with KitchenCare™ • 1-844-724-CARE • www.mtwkitchencare.com



To learn how Manitowoc Foodservice and its leading brands can equip you, visit our global web site at www.manitowocfoodservice.com, then discover the regional or local resources available to you.

