

Models 2803, 11M, 44M, 50M Post-Mix Soda & SC180, SC340, SC1000, & SC2000 Super-Chill Refrigeration Units

Installation, Use & Care Manual

This manual is updated as new information and models are released.
Visit our website for the latest manual. www.manitowocfsg.com

Safety Notices

As you work on Manitowoc equipment, be sure to pay close attention to the safety notices in this manual. Disregarding the notices may lead to serious injury and/or damage to the equipment.

Throughout this manual, you will see the following types of safety notices:

Warning

Text in a Warning box alerts you to a potential personal injury situation. Be sure to read the Warning statement before proceeding, and work carefully.

Caution

Text in a Caution box alerts you to a situation in which you could damage the equipment. Be sure to read the Caution statement before proceeding, and work carefully.

Procedural Notices

As you work on Manitowoc equipment, be sure to read the procedural notices in this manual. These notices supply helpful information which may assist you as you work.

Throughout this manual, you will see the following types of procedural notices:

Important

Text in an Important box provides you with information that may help you perform a procedure more efficiently. Disregarding this information will not cause damage or injury, but it may slow you down as you work.

NOTE: Text set off as a Note provides you with simple, but useful, extra information about the procedure you are performing.

Read These Before Proceeding:

Caution

Proper installation, care and maintenance are essential for maximum performance and trouble-free operation of your Manitowoc equipment. Read and understand this manual. It contains valuable care and maintenance information. If you encounter problems not covered by this manual, do not proceed, contact Manitowoc Foodservice Group. We will be happy to provide assistance.

Important

Routine adjustments and maintenance procedures outlined in this manual are not covered by the warranty.

Warning

PERSONAL INJURY POTENTIAL

Do not operate equipment that has been misused, abused, neglected, damaged, or altered/modified from that of original manufactured specifications.

NOTE: SAVE THESE INSTRUCTIONS.

We reserve the right to make product improvements at any time. Specifications and design are subject to change without notice.

Table of Contents (continued)

Section 1

General Information

Read This Manual	1-1
Unit Inspection	1-1
Model Numbers	1-1
How to Read a Model Number	1-1
Accessories	1-2
Special Applications	1-2
Attention: Marine Installations	1-2
Outdoor Applications	1-2
Specifications	1-2
Serial Plate Location	1-3
Warranty Information	1-3

Section 2

Installation

General	2-1
Dimensions and Clearances — All Models	2-1
Remote Condenser	2-2
Blade Tower	2-2
Safe Installation Dos and Don'ts	2-3
Location Requirements	2-4
Soda Refrigeration Unit "Quick-Pick" Selection Chart	2-4
Clearances	2-4
Ratings	2-4
Kitchen Equipment Installer Representative Responsibilities	2-5
Requirements for Post Mix Refrigeration Units	2-5
Installer Instructions	2-5
Preparation	2-5
Electrical	2-6
General	2-6
Minimum Circuit Ampacity	2-6
Electrical Requirements	2-6
Specifications	2-6
Grounding Instructions	2-7

Table of Contents (continued)

Plumbing/Water Supply	2-8
Plumbing Potable Water	2-8
Plumbing Requirements – General	2-8
Water Supply	2-8
Plumbing Circuit Diagrams — Model 2803	2-9
Plumbing Circuit Diagrams — Model 11M Root Beer	2-10
Plumbing Circuit Diagrams — Model 44M	2-13
Plumbing Circuit Diagrams — Model 50M	2-18
Refrigeration Unit Installation	2-20
Unpacking and Inspecting	2-20
Unit Installation Overview	2-20
Positioning of Refrigeration Unit	2-21
Equipment Placement	2-21
Electrical Connections	2-21
Tower Installation	2-21
Conduit Installation	2-22
Proper Use of John Guest Fittings	2-22
Connecting Supply Lines	2-23
Routing Insulated Conduit	2-25
Connecting Insulated Conduit at the Unit	2-25
Connecting Insulated Supply Lines	2-25
Insulating Connections	2-28
Aeroquip Connection	2-28
Condenser and Pre-charged Lines Installation	2-28
Remote Condenser Requirements	2-28
Pre-charged Refrigeration Line Requirements	2-29
Installing the Multiplex Remote Condenser	2-29
Connecting the Pre-charged Refrigeration Lines	2-30
Testing	2-30
Testing CO ₂ Circuit for Leaks	2-30
Testing Syrup Circuit (5 gallon tanks only)	2-30
Preparing Ice Bank	2-30
Building an Ice Bank	2-30
Installation Checklist	2-31

Table of Contents (continued)

Section 3 Operation

Typical System	3-1
How the Multiplex Works	3-2
Differences Between the TS & SS Units	3-2
Water Manifold TS	3-3
Electrical TS	3-3
Water Bath Access SS	3-4
Water Bath Access TS	3-4
Service Access SS	3-4
Service Access TS	3-4
Start-up (Non-ERC)	3-4
Placing Equipment in Operation	3-4
Placing the Carbonation System in Operation	3-5
Sequence of Operation	3-6
Pre-mix Refrigeration Unit	3-6
Equipment Setup and Close Procedure	3-7
Equipment Setup Procedure	3-7
Equipment Close Procedure	3-7

Section 4 Maintenance

Sanitizing	4-1
Beverage System Cleaning	4-1
Bag-In-Box System Sanitation	4-1
Figal Beverage System	4-2
Back-flow Preventer Maintenance	4-3
Shipping, Storage and Relocation	4-3

Section 5 Before Calling for Service

Checklist	5-1
------------------------	------------

THIS PAGE INTENTIONALLY LEFT BLANK

Section 1 General Information

Read This Manual

Manitowoc Food Service developed this manual as a reference guide for the owner/operator and installer of this equipment. Please read this manual before installation or operation of the machine. A qualified service technician must perform installation and start-up of this equipment, consult **Section 5** within this manual for service assistance.

If you cannot correct the service problem, call your Manitowoc Beverage Equipment (MBE) Service Agent or Distributor. Always have your model and serial number available when you call.

Your Service Agent _____

Service Agent Telephone Number _____

Your Local MBE Distributor _____

Distributor Telephone Number _____

Model Number _____

Serial Number _____

Installation Date _____

Unit Inspection

Thoroughly inspect the unit upon delivery. Immediately report any damage that occurred during transportation to the delivery carrier. Request a written inspection report from a claims inspector to document any necessary claim.

Warning

PERSONAL INJURY POTENTIAL

Do not operate equipment that has been misused, abused, neglected, damaged, or altered/modified from that of original manufactured specifications.

Model Numbers

This manual covers the following models:

Post Mix Soda Refrigeration Unit
2803A04, 2803AX04, 2803A04 11MA04, 11MAX04, 11MA04, 44MA04, 44MAX04T, 44MW04, 44MWX04T, 44MR04, 44MRX04T, 44EAX04T, 44EWX04T, 50MA04, 50MAX04, 50MR04, 50MRX04, 50MW04, 50MWX04, 50MR04Q/T, SC180A, SC180AX, SC180R, SC180RX, SC180W, SC180WX, SC340A, SC340AX, SC340R, SC340RX, SC340W, SC340WX, SC1000A, SC1000AX, SC1000R, SC1000RX, SC1000W, SC1000WX, SC2000A, SC2000AX, SC2000R, SC2000RX, SC2000W, SC2000WX

How to Read a Model Number

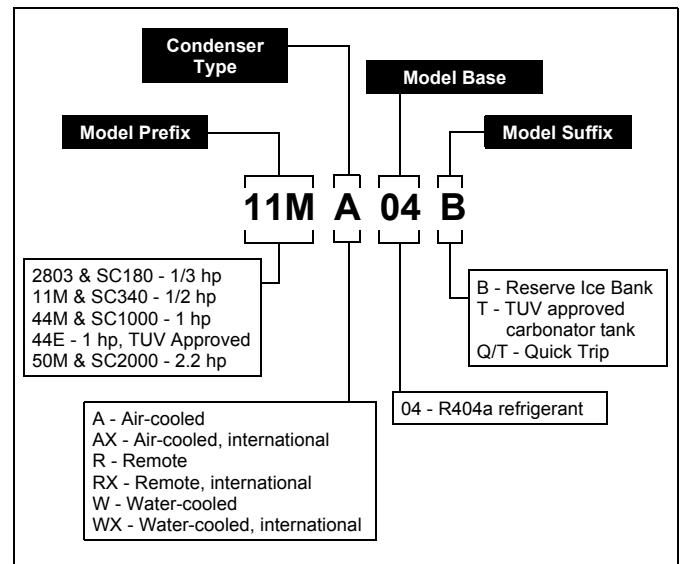

Accessories

Depending on store type and location, various optional equipment (such as CO₂ Panel, water filter kit, water booster kit, etc.) may be added to this system. Install and connect any optional equipment in the desired location according to the installation instructions provided with these kits/equipment.

Special Applications

ATTENTION: MARINE INSTALLATIONS

 **Warning**

This unit is for use on vessels over 66 ft (20 m) in length. This unit must not be installed in the engine space of a gasoline-powered ship.

NOTE: This unit must be secured to the vessel during installation. Models with part numbers beginning with the letters TS are NOT marine listed.

OUTDOOR APPLICATIONS

TS Multiplex Beverage Recirculating units are approved and listed by Underwriters Laboratories (UL). However they are not UL approved for weather exposure applications. These units must be installed in areas where adequate protection from the elements is provided, all other models are ETL listed.

Specifications

Model	Number of Dispensing Heads	Type of Container
2803	One 6-valve soda tower	Bag-in-Box
11M	One 6-valve soda tower or up to three 2-valve root beer towers	Bag-in-Box
44M	Up to two 8-valve soda towers	Bag-in-Box
50M	Up to two 8-valve soda towers	Bag-in-Box

NOTE: Super-Chill units do not apply to the above table, they are only used to chill large amounts of water.

Serial Plate Location

MULTIPLEX
A Manitowoc Company

Manitowoc Ice, Inc.
2110 S. 26th St.
P.O. Box 1720
Manitowoc, WI 54221-1720

REMOTE REFRIGERATION UNIT

MODEL 50MR04 PART NUMBER 78905051-263 SERIAL NUMBER XXXXX 8766

ELECTRICAL RATING: 208-230 VAC 60HZ 3PH

COMPONENT	QTY	VOLTS	AMPERES	POWER
COMPRESSOR	01	208-230	7.1 RLA 40.0 LRA	
FAN MOTOR	01	230	1.0	
CARBONATOR MOTOR	02	230	5.0	
CIRCULATOR MOTOR	02	230	5.0	
AGITATOR MOTOR	01	230	0.4	
SOLENOID	01	230	0.1	

MAX. FUSE OR HACR TYPE CIRCUIT BREAKER: 30A REFRIGERANT: R404A

MINIMUM BRANCH CIRCUIT AMPACITY: 20.4 UNIT CHARGE: 144 OZ

REFRIGERATION DESIGN PRESSURE: HI-500 PSIG LO-250 PSIG

IF A SUPPORT STAND IS USED, USE ONLY MULTIPLEX MODEL: 4450

SYRUP LINE PRESSURE MUST NOT EXCEED 75 PSIG. CHECK INSTRUCTIONS FOR PROPER CO₂ PRESSURE SETTINGS.

FOR USE WITH REMOTE CONDENSER TS0895

NSF c UL US LISTED Made in USA

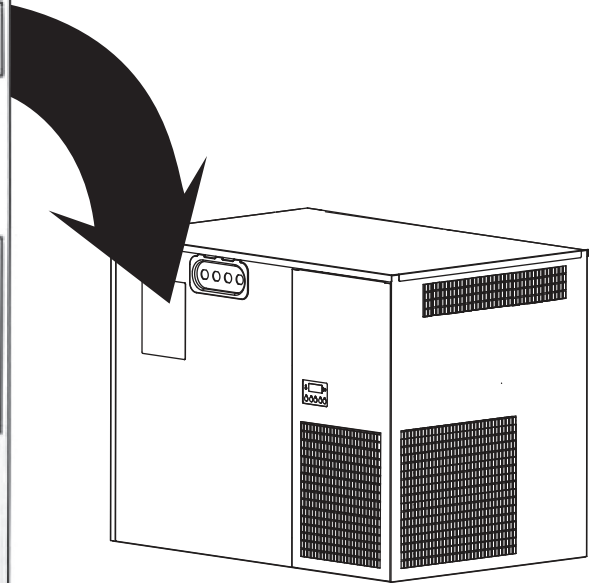

Warranty Information

Consult your local MBE Distributor for terms and conditions of your warranty. Your warranty specifically excludes all beverage valve brixing, general adjustments, cleaning, accessories and related servicing.

Your warranty card must be returned to MBE to activate the warranty on this equipment. If a warranty card is not returned, the warranty period can begin when the equipment leaves the MBE factory.

No equipment may be returned to MBE without a written Return Materials Authorization (RMA). Equipment returned without an RMA will be refused at MBE's dock and returned to the sender at the sender's expense.

Please contact your local MBE distributor for return procedures.

THIS PAGE INTENTIONALLY LEFT BLANK

REMOTE CONDENSER

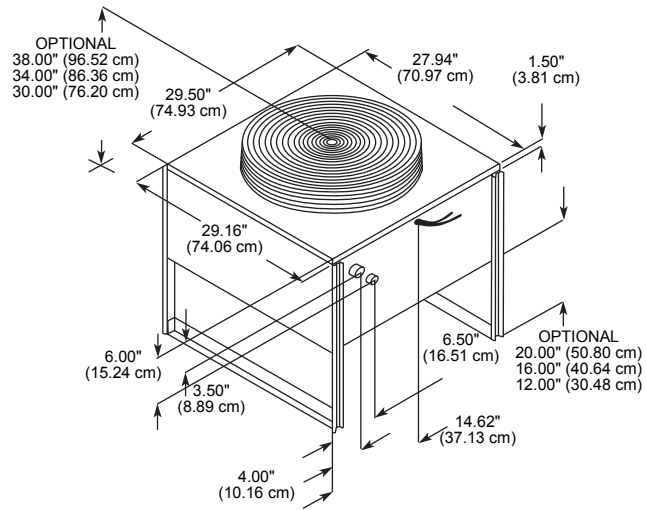

BLADE TOWER

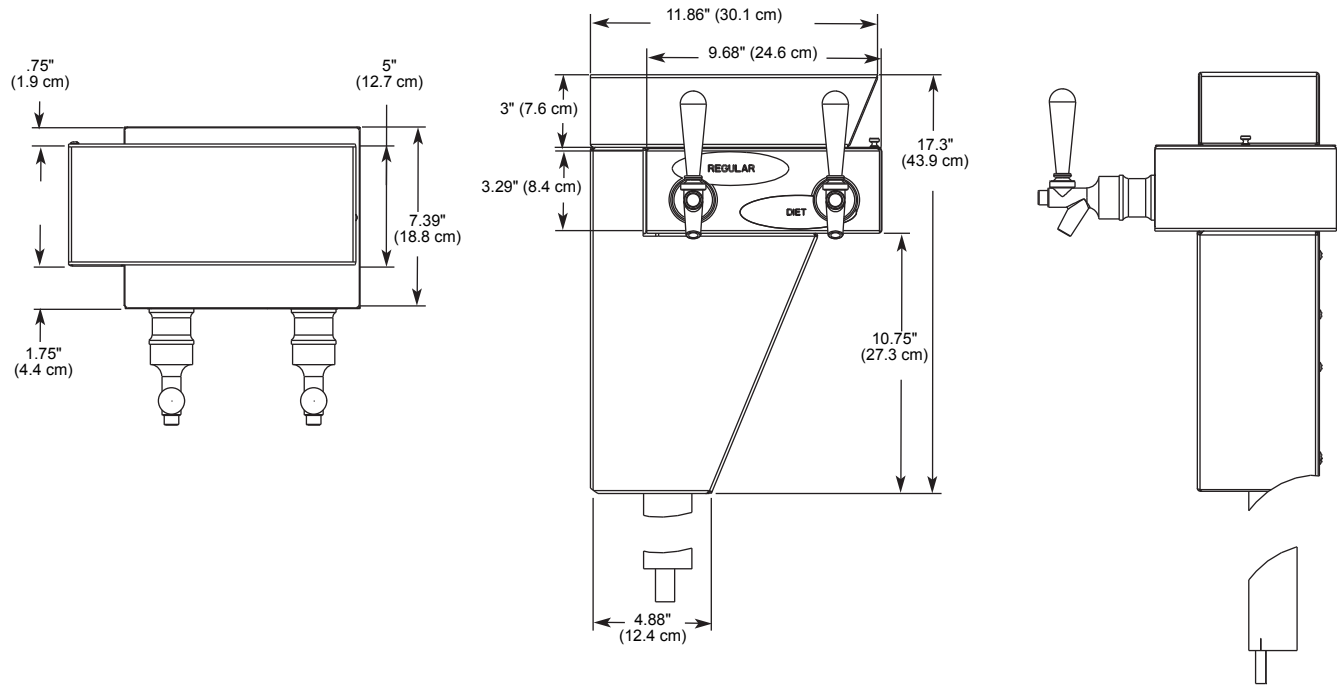

Safe Installation Dos and Don'ts

 **Warning**

Read the following warnings before beginning an installation. Failure to do so may result in possible death or serious injury.

- **DO** adhere to all National and Local Plumbing and Electrical Safety Codes.
- **DO** turn OFF incoming electrical service switches when servicing, installing, or repairing equipment.
- **DO** check that all flare fittings are tight. This check must be performed with a wrench to ensure a quality seal.
- **DO** inspect pressure on regulators before starting up equipment.
- **DO** protect eyes when working around refrigerants.
- **DO** use caution when handling metal surface edges of all equipment.
- **DO** handle CO₂ cylinders and gauges with care. Secure cylinders properly against abrasion.
- **DO** store CO₂ cylinder(s) in well ventilated areas.
- **DO NOT** exhaust CO₂ gas (example: syrup pump) into an enclosed area, including all types of walk-in coolers, cellars, and closets.
- **DO NOT** throw or drop a CO₂ cylinder. Secure the cylinder(s) in an upright position with a chain.
- **DO NOT** connect the CO₂ cylinder(s) directly to the product container. Doing so will result in an explosion causing possible death or injury. It is best to connect the CO₂ cylinder(s) to a regulator(s).
- **DO NOT** store CO₂ cylinders in temperature above 125°F (51.7°C) near furnaces, radiator or sources of heat.
- **DO NOT** release CO₂ gas from old cylinder.
- **DO NOT** touch refrigeration lines inside units; some may exceed temperatures of 200°F (93.3°C).

NOTICE: All utility connections and fixtures must be sized, installed, and maintained in accordance with Federal, State, and Local codes.

Location Requirements

SODA REFRIGERATION UNIT “QUICK-PICK” SELECTION CHART

Business Level*	Number of Dispensing Stations			
	1	2	3	4
Up to 6 gal / 3 L of syrup/day or 280 drinks/day (2,000 gal/yr)	Model 2803 40 ft / 12 m Maximum Conduit Length	Model 11M 100 ft / 30 m Maximum Conduit Length	Model 44M 250 ft / 80 m Maximum Conduit Length	Model 44M 250 ft / 80 m Maximum Conduit Length
Up to 12 gal / 45 L of syrup/day or 560 drinks/day (4,000 gal/year)	Model 11M 100 ft / 30 m Maximum Conduit Length	Model 11M 100 ft / 30 m Maximum Conduit Length	Model 44M 250 ft / 80 m Maximum Conduit Length	Model 44M 250 ft / 80 m Maximum Conduit Length
Up to 21 gal / 79 L of syrup/day or 980 drinks/day (7,500 gal/yr)	Model 44M 250 ft / 80 m Maximum Conduit Length	Model 44M 250 ft / 80 m Maximum Conduit Length	Model 44M 250 ft / 80 m Maximum Conduit Length	Model 44M 250 ft / 80 m Maximum Conduit Length
Up to 32 gal / 121 L of syrup/day or 1400 drinks/day (11,500 gal/yr)	Model 44M 250 ft / 80 m Maximum Conduit Length	Model 44M 250 ft / 80 m Maximum Conduit Length	Model 50M 350 ft / 107 m Maximum Conduit Length	Model 50M 350 ft / 107 m Maximum Conduit Length
Up to 42 gal / 159 L of syrup/day or 2000 drinks/day (15,000 gal/yr)	Model 50M 350 ft / 107 m Maximum Conduit Length	Model 50M 350 ft / 107 m Maximum Conduit Length	Model 50M 350 ft / 107 m Maximum Conduit Length	Model 50M 350 ft / 107 m Maximum Conduit Length

* Care must be taken when selecting the proper refrigeration unit. Above selections are for 75°F (24°C) conditions, 16 ounce (470 ml) drinks, and average business cycles. Other factors such as lunch or dinner peak periods, large drinks, or high ambient conditions may require the next larger size unit. Contact your Manitowoc Company Authorized Distributor or Manitowoc Beverage Systems (MBS) for more information.

CLEARANCES

Control Side (Right)	18" (45.7 cm)
Tower Connection Side (Left)	12" (30.5 cm)
Back Side	6" (15.2 cm)
Ceiling	18" (45.7 cm)

RATINGS

Model	Evaporator Rating at 20°F (-6.5°C)	Heat Rejection (Max.)
Model 2803 & SC180	2,500 BTUH 490 kcal/hr	4,500 BTUH 885 kcal/hr
Model 11M & SC340	5,150 BTUH 1,159 kcal/hr	8,638 BTUH 1,949 kcal/hr
Model 44M & SC1000	9,700 BTUH 2,340 kcal/hr	13,576 BTUH 3,685 kcal/hr
Model 50M & SC2000	14,900 BTUH 3,310 kcal/hr	20,400 BTUH 4,285 kcal/hr

Select a location for the refrigeration unit that meets the requirements of the building plans, local codes, and personnel. The unit must be positioned for free airflow

as well as for future service. The following requirements must be met:

- 100 GPH (379 LTR/hr) potable water supply Models 2803/11/38; 200 GPH (757 LTR/hr) potable water supply Models 44/50
- Beverage quality CO₂ gas (bulk or bottled supply) with a minimum 3/8" (.96 cm) line
- One Bag-In-Box (BIB) container of each post mix syrup flavor.

NOTE: Refer to nameplate on side of refrigeration unit for voltage and amperage specifications. Make all electrical connections at the junction box located at the top rear of unit. Optional equipment may require additional power supplies.

NOTE: Potable water connections to the equipment must comply with local plumbing code requirements, particularly the back-flow prevention requirements.

 **Warning**

Carbon Dioxide (CO₂) displaces oxygen. Exposure to a high concentration of CO₂ gas causes tremors, which are followed rapidly by loss of consciousness and suffocation. If a CO₂ gas leak is suspected, particularly in a small area, immediately ventilate the area before repairing the leak. CO₂ lines and pumps must not be installed in an enclosed space. An enclosed space can be a cooler or small room or closet. This may include convenience stores with glass door self serve coolers. If you suspect CO₂ may build up in an area, venting of the BIB pumps and/or CO₂ monitors must be utilized.

**KITCHEN EQUIPMENT INSTALLER
REPRESENTATIVE RESPONSIBILITIES**

Prior to scheduling Multiplex Equipment installer, the following steps listed below must be completed:

1. Usable floor sewer drain.
2. A 120 VAC, 3-wire, 1 Phase, 60 Hz Electrical Power Supply (minimum 30 Amp capacity).
 - Model 44 is 208/230, 3-wire, 1 Ph 60 Hz
 - Model 50 is 208/230, 4-wire, 3Ph 60 Hz
 - International Models are 50 Hz
3. Usable potable water.
4. CO₂ Gas (bulk or bottled supply); minimum 3/8" line.
5. One 5 gallon (19 L) container or Bag-In-Box container of each post mix syrup flavor.
6. A 120 VAC, 3-wire, 1 Phase, 60 Hz dual wall receptacle for optional electrical equipment (domestic only).

NOTE: Do not schedule the authorized Multiplex Equipment Installer until all of the above have been completed. It will only result in charge-backs to you for the unnecessary trips.

REQUIREMENTS FOR POST MIX REFRIGERATION UNITS

- Conduit can be run through floor or ceiling chase.
- 60°F (15.6°C) minimum and 105°F (40.5°C) maximum operating ambient conditions.
- For indoor installation only.
- Syrup supply can be located on stand or adjacent to refrigeration unit.

Installer Instructions

Important

The remainder of these instructions is to be completed by an authorized Multiplex Installer.

These equipment instructions are intended to assist qualified personnel in the unpacking, locating and the initial operation of the Multiplex Beverage Equipment Post Mix Refrigeration Unit.

Important

This publication must be saved for future reference. Read instructions before attempting installation.

PREPARATION

The Multiplex Beverage Equipment Post Mix Refrigeration Unit is pre-assembled in the factory and requires minimum installation.

For future reference or to be used when ordering parts, record the Model Number, Serial Number, Part Numbers of Unit, Condenser (if remote), Towers, etc., and Date of Installation on the inside of this Manual. Leave manual on site in a safe place. Do not discard manual.

Ambient Location Requirement

This equipment is rated for indoor use only. It will not operate in sub-freezing temperature. In a situation when temperatures drop below freezing, the equipment must be turned off immediately and properly winterized. Contact the manufacturer for winterization process.

Electrical

GENERAL

 Warning All wiring must conform to local, state and national codes.

ELECTRICAL REQUIREMENTS

Refer to Ice Machine Model/Serial Plate for voltage/amperage specifications.

MINIMUM CIRCUIT AMPACITY

The minimum circuit ampacity is used to help select the wire size of the electrical supply. (Minimum circuit ampacity is not the beverage/ice machine's running amp load.) The wire size (or gauge) is also dependent upon location, materials used, length of run, etc., so it must be determined by a qualified electrician.

SPECIFICATIONS

Model	Volt/Cycle/Phase	Minimum Circuit Amps	Breaker	Compressor
2803 & SC180	120/60/1 230/50/1	20.3 9.0	25A 16A	1/3 hp .46 kW
11M & SC340	120/60/1 230/50/1	21.5 10.7	30A 16A	1/2 hp .97 kW
44M & SC1000	208-230/60/1 230/50/1	20.6 20.6	30A 25A	1 hp 1.9 kW
50M	120* /208-230/60/3 230/400/50/3	25.2 11.6	30A 20A	2.2 hp 2.0 kW
SC2000	208-230/60/3 230/400/50/3	25.2 11.6	20A 15A	2.2 hp 2.0 kW

* Only the model 50M with SS part numbers have 120V components, the TS does not.

GROUNDING INSTRUCTIONS

 **Warning**

The beverage/ice machine must be grounded in accordance with national and local electrical codes.

This appliance must be grounded. In the event of malfunction or breakdown, grounding provides a path of least resistance for electric current to reduce the risk of electric shock. This appliance is equipped with a cord having an equipment-grounding conductor and a grounding plug. The plug must be plugged into an appropriate outlet that is properly installed and grounded in accordance with all local codes and ordinances.

NOTE: The 208/230V units are not equipped with a cord.

 **Warning**

Improper connection of the equipment-grounding conductor can result in a risk of electric shock. The conductor with insulation having an outer surface that is green with or without yellow stripes is the equipment grounding conductor. If repair or replacement of the cord or plug is necessary, do not connect the equipment-grounding conductor to a live terminal. Check with a qualified electrician or serviceman if the grounding instructions are not completely understood, or if in doubt as to whether the appliance is properly grounded. Do not modify the plug provided with the appliance — if it will not fit the outlet, have a proper outlet installed by a qualified electrician.

 **Warning**

When using electric appliances, basic precautions must always be followed, including the following:

- a. Read all the instructions before using the appliance.
- b. To reduce the risk of injury, close supervision is necessary when an appliance is used near children.
- c. Do not contact moving parts.
- d. Only use attachments recommended or sold by the manufacturer.
- e. Do not use outdoors.
- f. For a cord-connected appliance, the following shall be included:
 - Do not unplug by pulling on cord. To unplug, grasp the plug, not the cord.
 - Unplug from outlet when not in use and before servicing or cleaning.
 - Do not operate any appliance with a damaged cord or plug, or after the appliance malfunctions or is dropped or damaged in any manner. Contact the nearest authorized service facility for examination, repair, or electrical or mechanical adjustment.
- g. For a permanently connected appliance — Turn the power switch to the off position when the appliance is not in use and before servicing or cleaning.
- h. For an appliance with a replaceable lamp — Always unplug before replacing the lamp. Replace the bulb with the same type.
- i. For a grounded appliance — Connect to a properly grounded outlet only. See Grounding Instructions.

Plumbing/Water Supply

PLUMBING POTABLE WATER

Model	Required Water Pressure	Drain Connections	Water Supply
2803 & SC180	40 – 70 psig (2.8 – 4.9 bar)	3/4" ID within 6 ft (2 m)	3/8" ID EVA Line
11M & SC340	40 – 70 psig (2.8 – 4.9 bar)	3/4" ID within 6 ft (2 m)	3/8" ID EVA Line
44M & SC1000	40 – 70 psig (2.8 – 4.9 bar)	3/4" ID within 6 ft (2 m)	1/2" ID EVA Line
50M	40 – 70 psig (2.8 – 4.9 bar)	3/4" ID within 6 ft (2 m)	1/2" ID EVA Line
SC2000	40 – 70 psig (2.8 – 4.9 bar)	3/4" ID within 6 ft (2 m)	1/2" ID EVA Line

A 1" (2.54 cm) ID copper inlet water line equipped with a 3/4" (1.905 cm) FPT sweat adapter with shut-off must be supplied by plumber at rear of equipment. Appropriate floor drains must be provided within 6 ft (183 cm) of each unit installed.

NOTE: The carbonator in this unit is provided with a dual check valve type back-flow preventer, which conforms to ASSE 1032. The Model 50M & 44M vented backflow preventer conforms to ASSE 1022.

Potable water connections to the equipment must comply with the basic plumbing code of the Building Officials and Code Administrators International, Inc. (BOCA) and the Food Service Sanitation Manual of the Food and Drug Administration. Verify local plumbing code requirements.

PLUMBING REQUIREMENTS – GENERAL

Incoming water supply must be provided before installation of the refrigeration unit and must comply with local plumbing requirements.

1. A minimum 1" (2.54 cm) water supply line with a manual shut-off valve must be plumbed at least 6 ft (183 cm) from the unit. The incoming water supply pressure must not exceed 70 psi static (4.8 bar) and be no less than 40 psi (2.8 bar) dynamic. If supply water pressure is greater than 70 psi (5 bar), a water regulator will be required.
2. Locate the drain hose, bracket, and two screws provided in the installation kit. Attach the drain hose to the water bath overflow tube located on the bottom of the refrigeration unit.

3. Connect the water manifold supply line, located on the bulkhead panel in the motor compartment to the main water supply. The main water supply shut-off valve must remain in the OFF position. If a water filter is to be installed, connect the line to the outlet fitting of the filter. Plumb according to applicable plumbing codes.

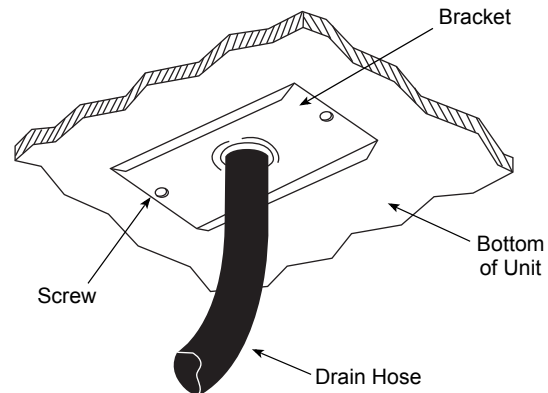

Drain Hose Connection

4. When a water cooled condenser is installed, a copper supply line (not supplied with unit) must be plumbed to the 3/8" (.965 cm) male flare fitting installed in the water shut-off assembly. The shut-off must be placed in the OFF position. A copper drain line (not supplied) is to be connected to the outlet fitting of the water cooled condenser and routed to the floor drain.

WATER SUPPLY

1. Use the built in fill valve that is already plumbed into the unit.
2. An appropriate floor drain is required within 6 ft (2 m) of the unit.
3. Potable water connections to the equipment must comply with the basic plumbing code of the Building Officials and Code Administrators International, Inc. (BOCA) and the Food Service Sanitation Manual of the Food and Drug Administration. Verify local plumbing code requirements.

PLUMBING CIRCUIT DIAGRAMS — MODEL 2803

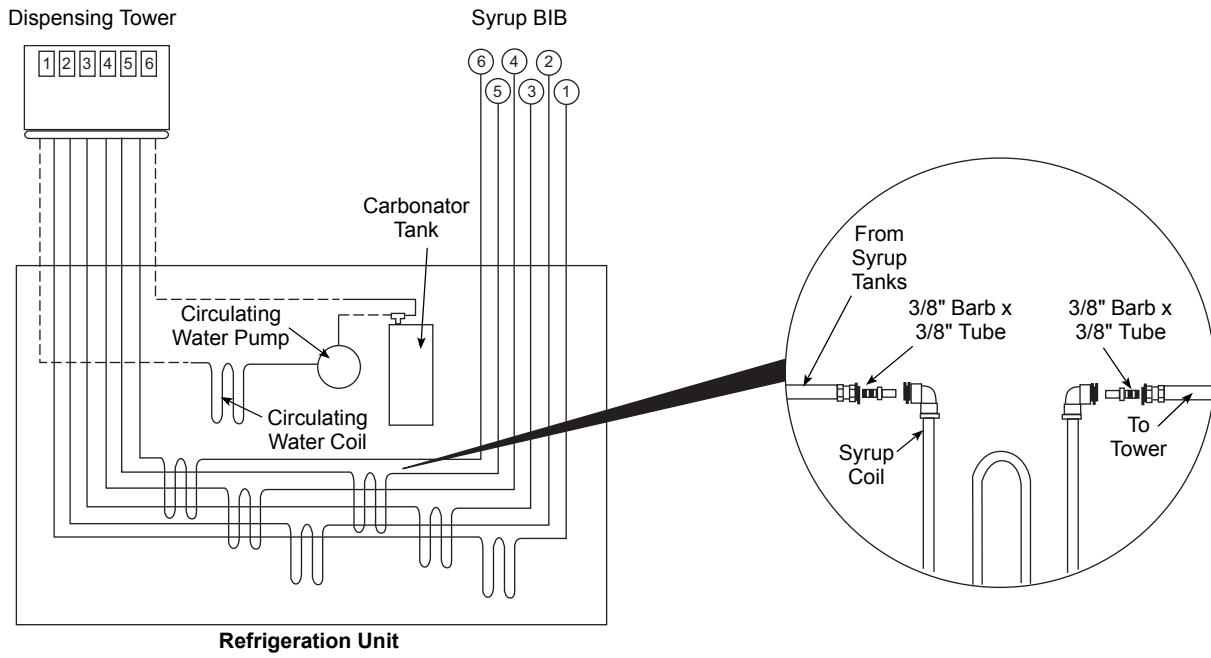

PLUMBING CIRCUIT DIAGRAMS — MODEL 11M ROOT BEER

Single Tower Plumbing

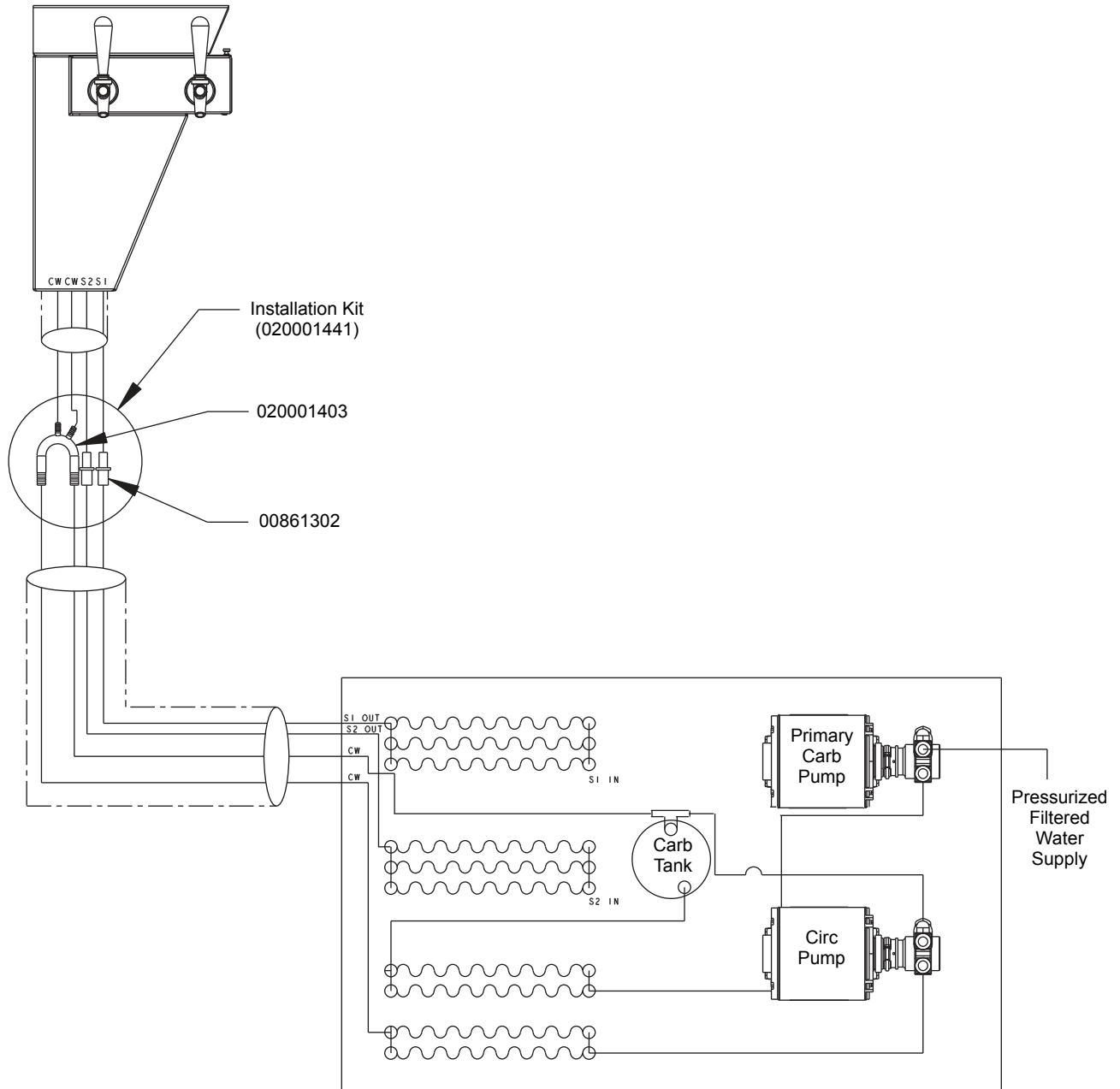

Model 11M Root Beer Dual Tower Plumbing

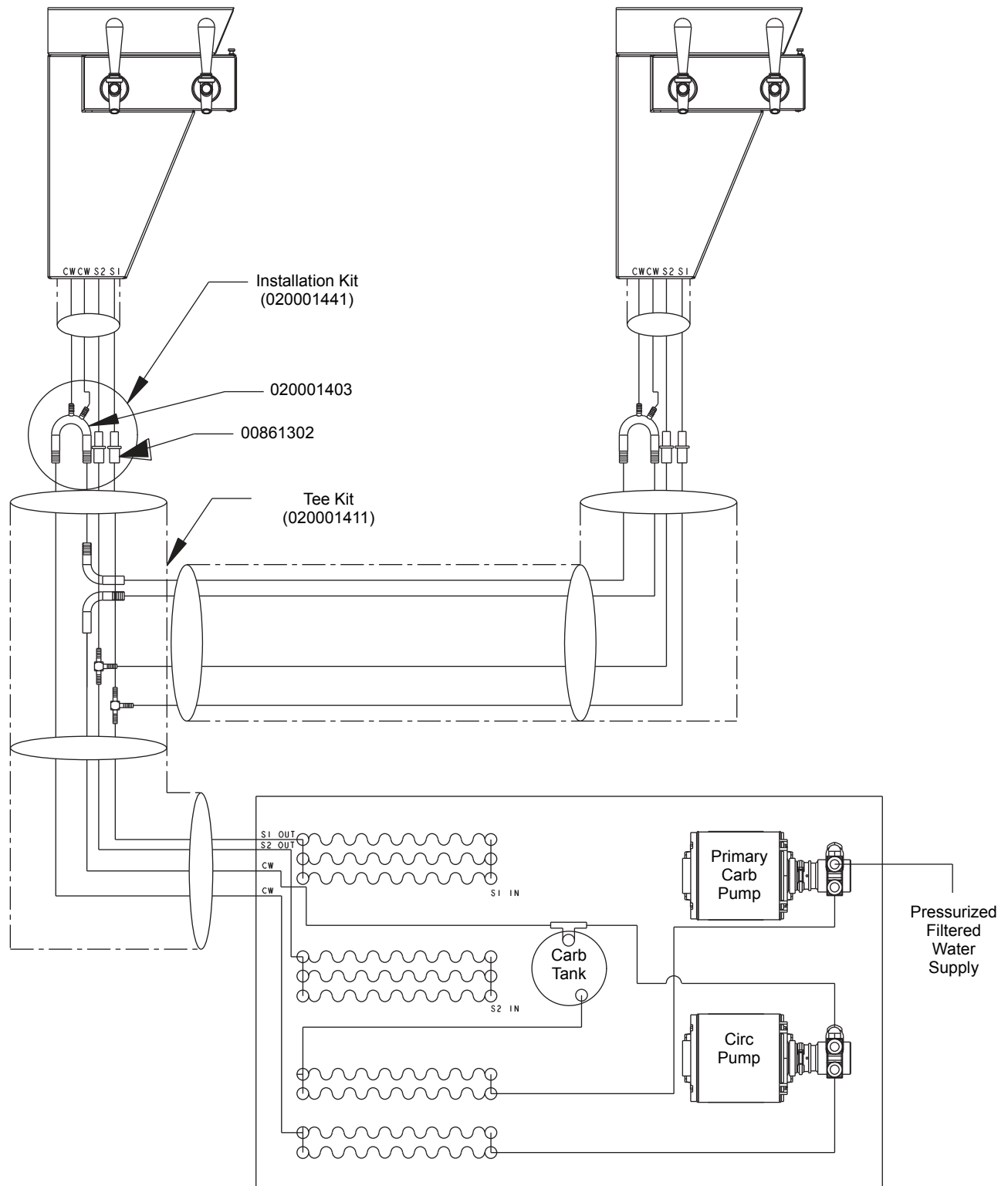

Model 11M Root Beer Three Tower Plumbing

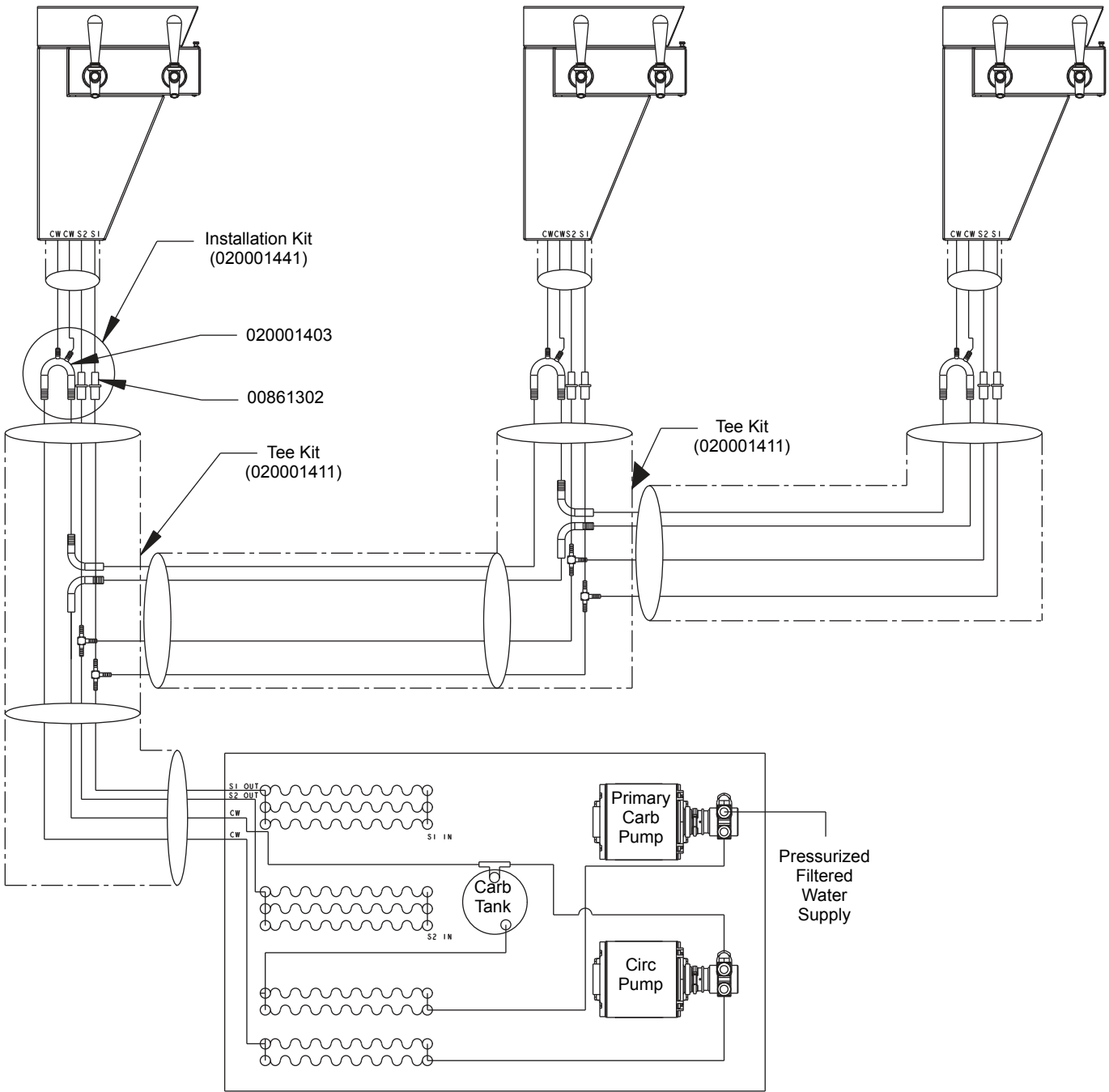

PLUMBING CIRCUIT DIAGRAMS — MODEL 44M

Pressurized Water Circuit Diagram

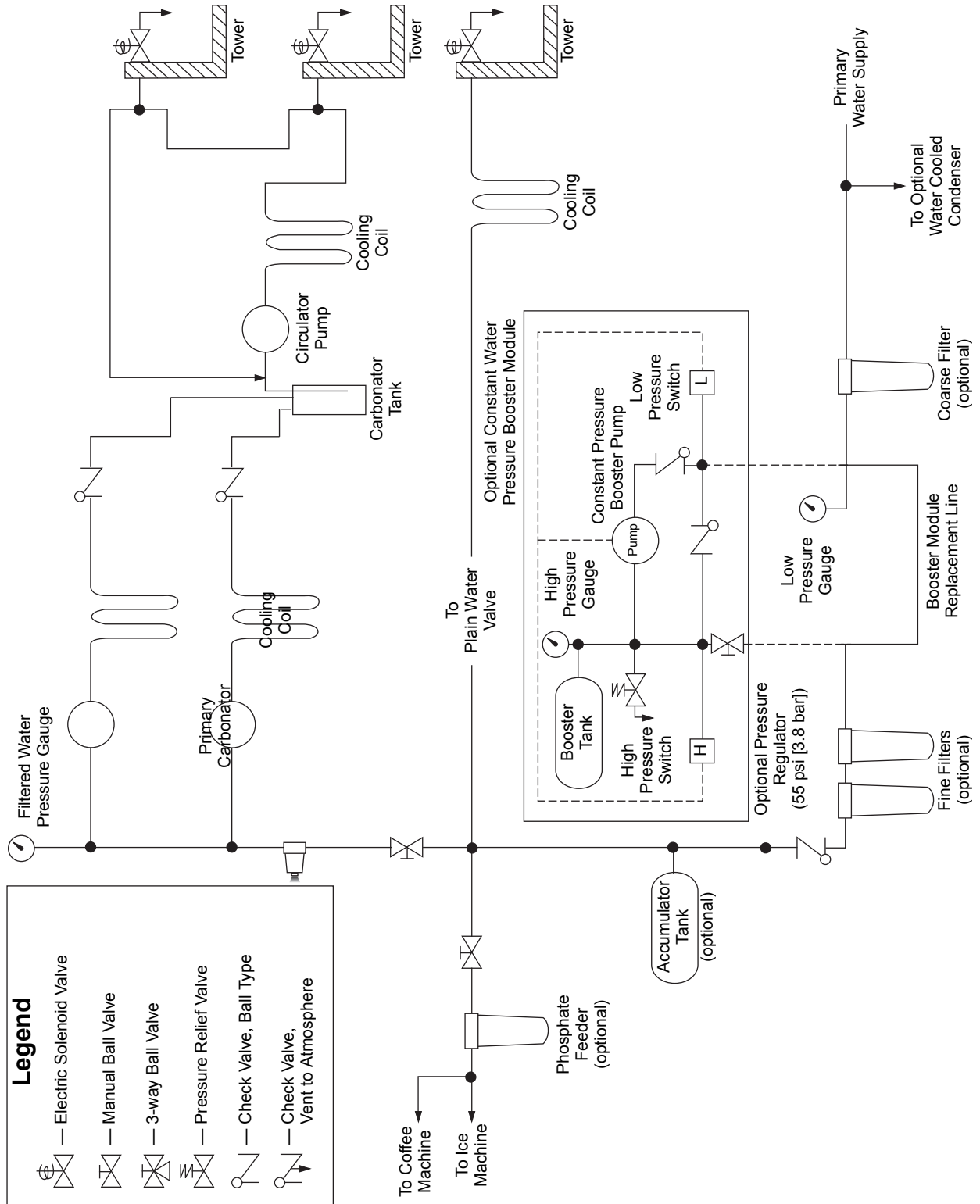

Pre-mix Plumbing — Six Valve Towers with Connection at Center Island

NOTE: Other plumbing configurations are possible. Check tower installation manual before making connections.

Single Tower System

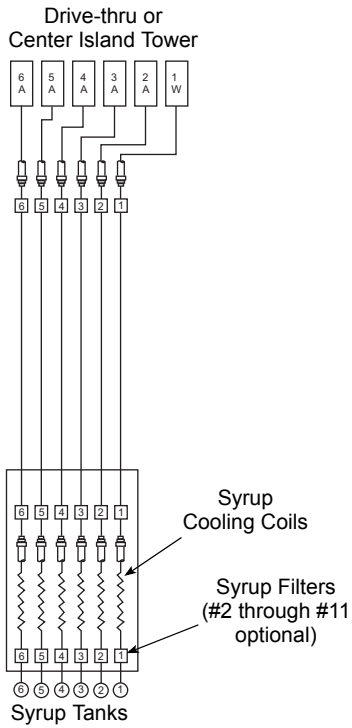

Two Tower System with Connection at Center Island

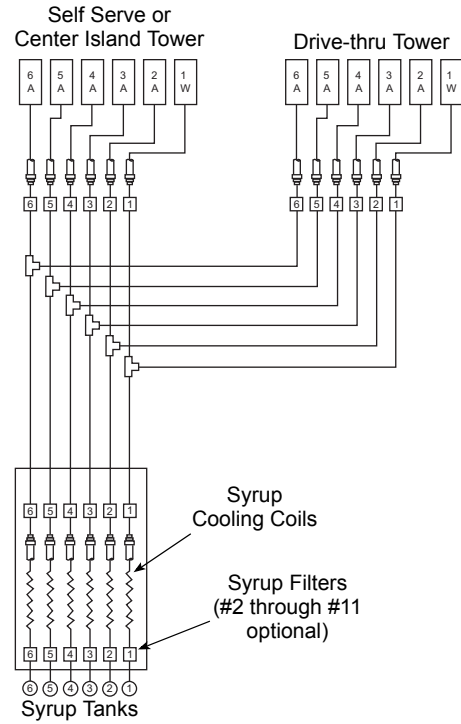

Three Tower System with Connection at Center Island

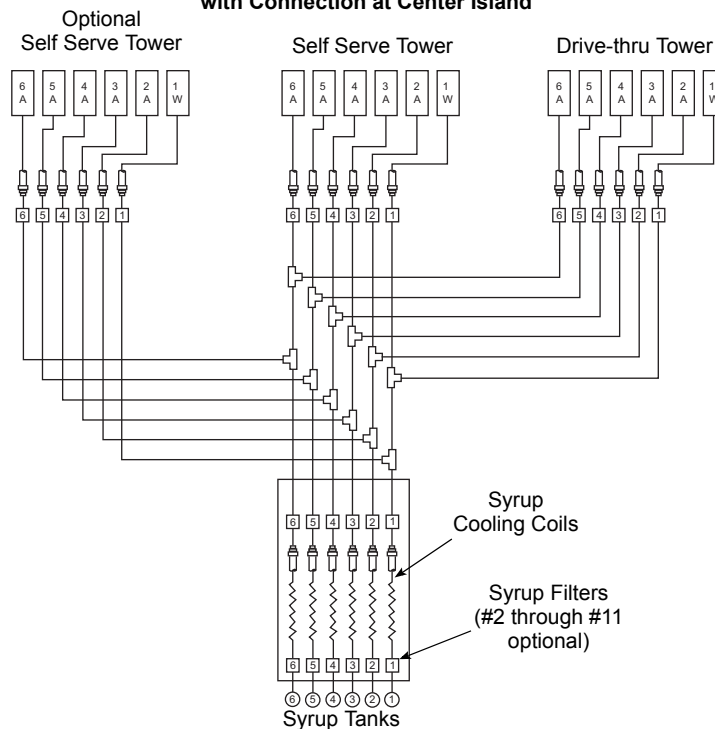

Pre-mix Plumbing — Eight Valve Towers with Connection at Center Island

Single Tower System

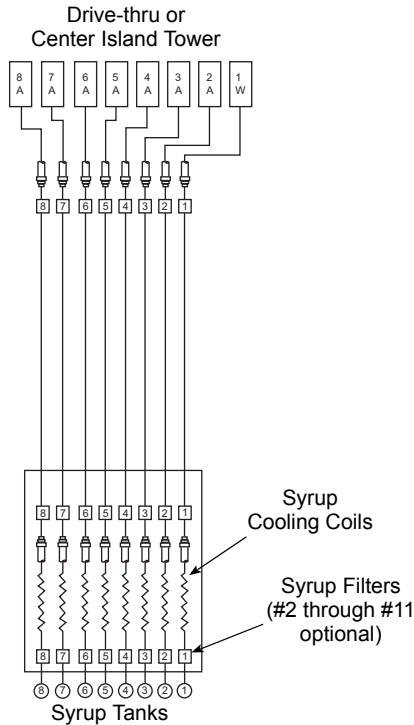

Two Tower System with Connection at Center Island

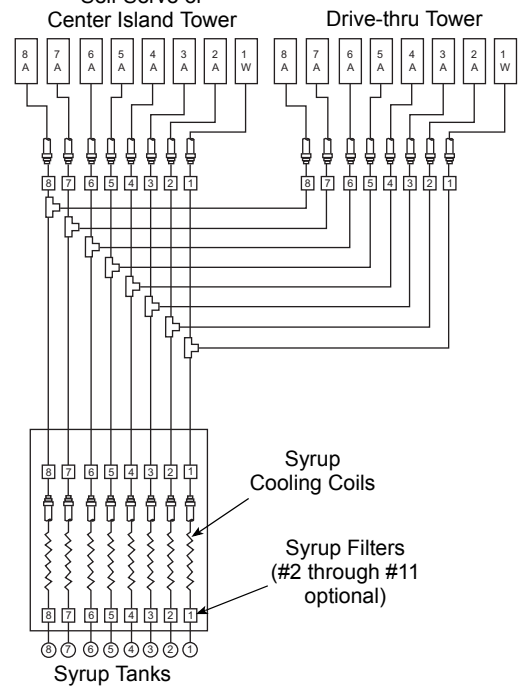

Three Tower System with Connection at Center Island

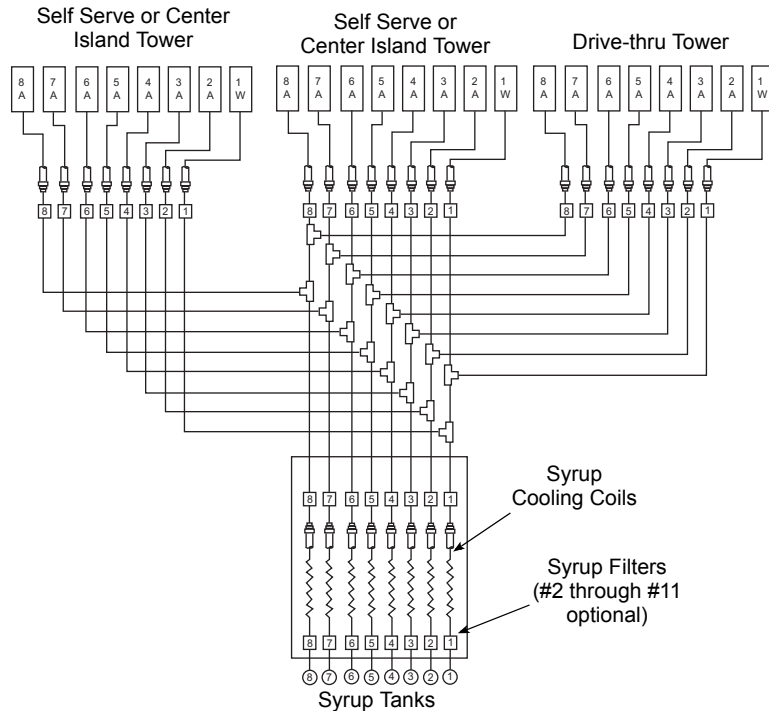

Carbonated Water Plumbing — Six Valve Towers with Connection at Unit

Supplies Carbonated Water to Diet Drink and Provides Conduit Cooling for Products

Single Tower System with Connection at Unit

Drive-thru or
Center Island Tower

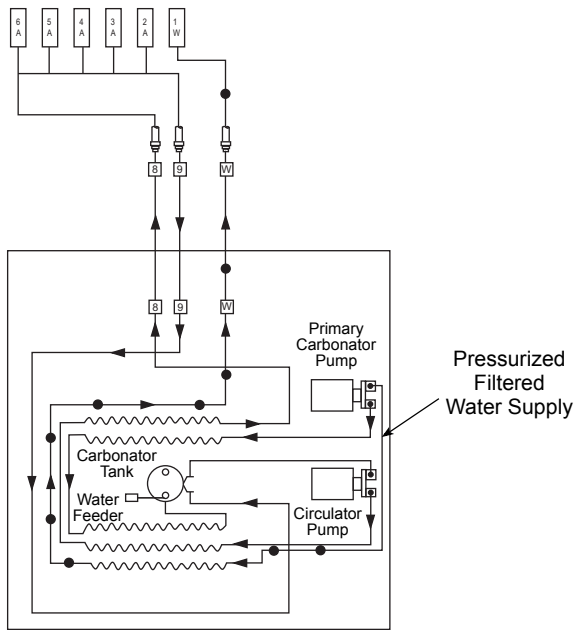

Two Tower System with Connection at Unit

Self Serve or
Center Island Tower Drive-thru Tower

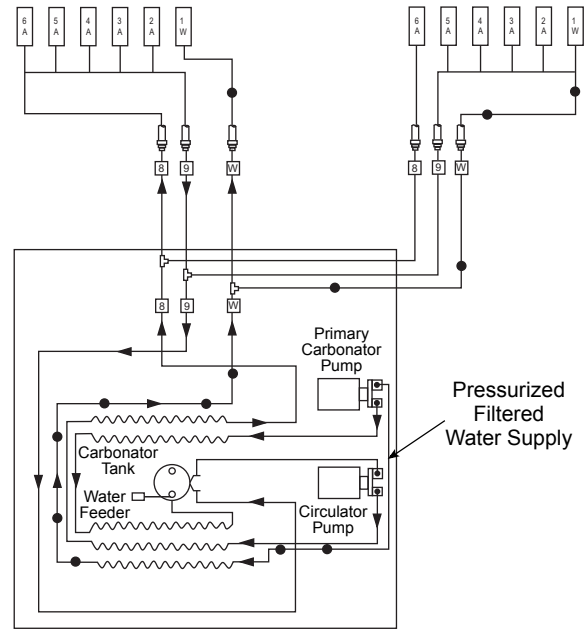

Three Tower System with Connection at Unit

Self Serve or Center
Island Tower (optional) Self Serve or
Center Island Tower Drive-thru Tower

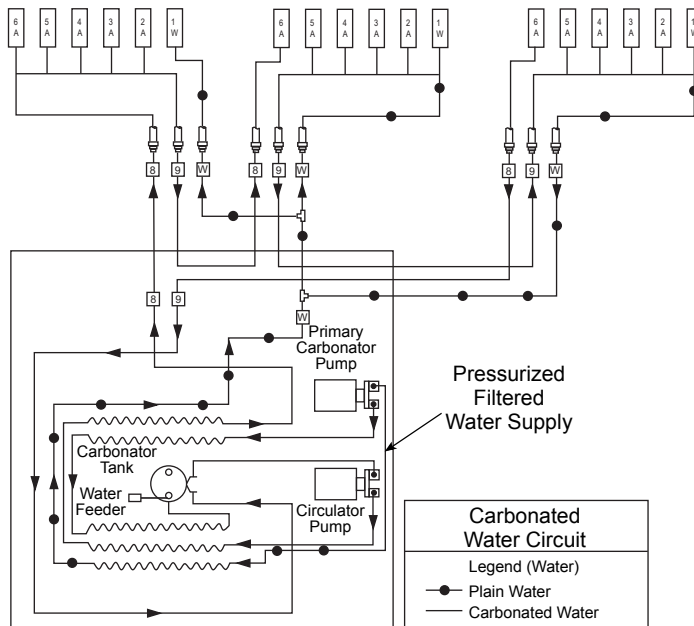

Carbonated Water Plumbing — Eight Valve Towers with Connection at Unit

Single Tower System with Connection at Unit

Drive-thru or
Center Island Tower

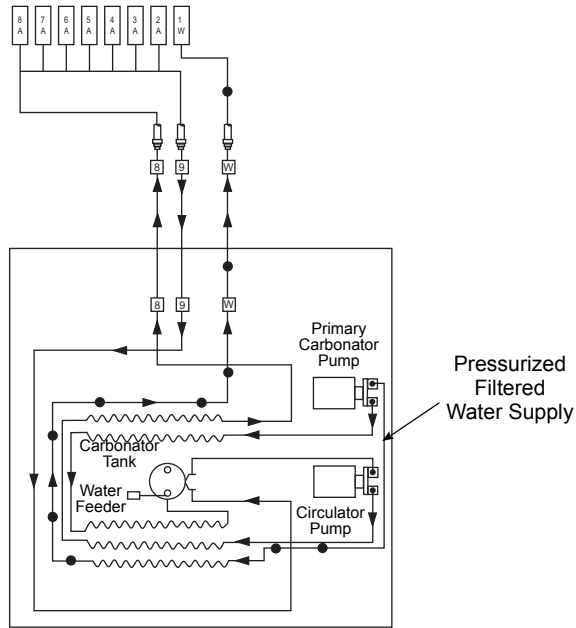

Two Tower System with Connection at Unit

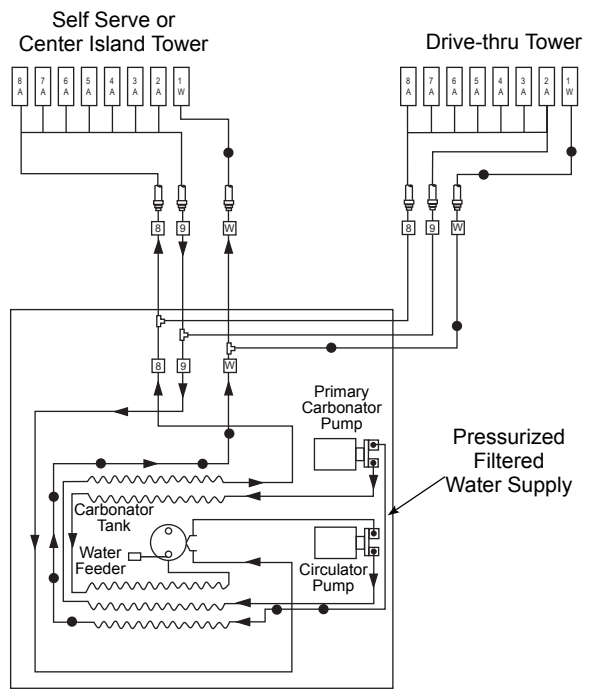

Three Tower System with Connection at Unit

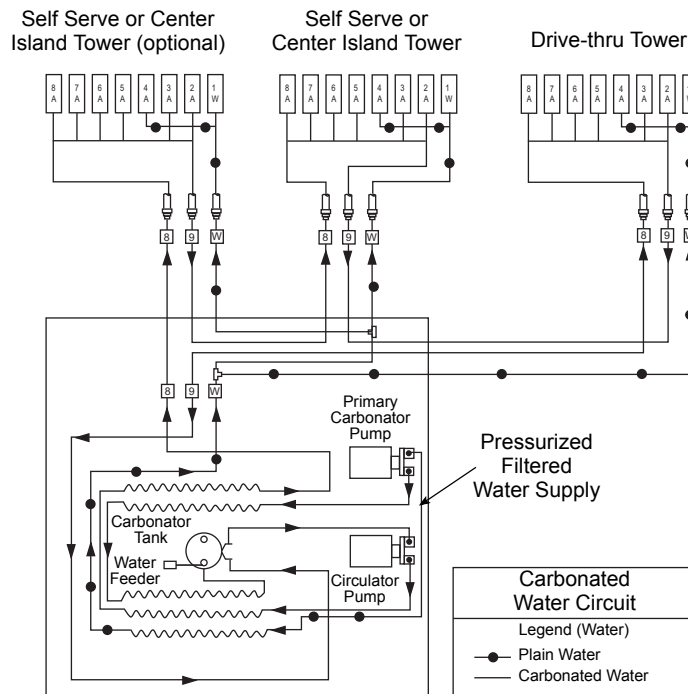

PLUMBING CIRCUIT DIAGRAMS — MODEL 50M

Pressurized Water Circuit Diagram

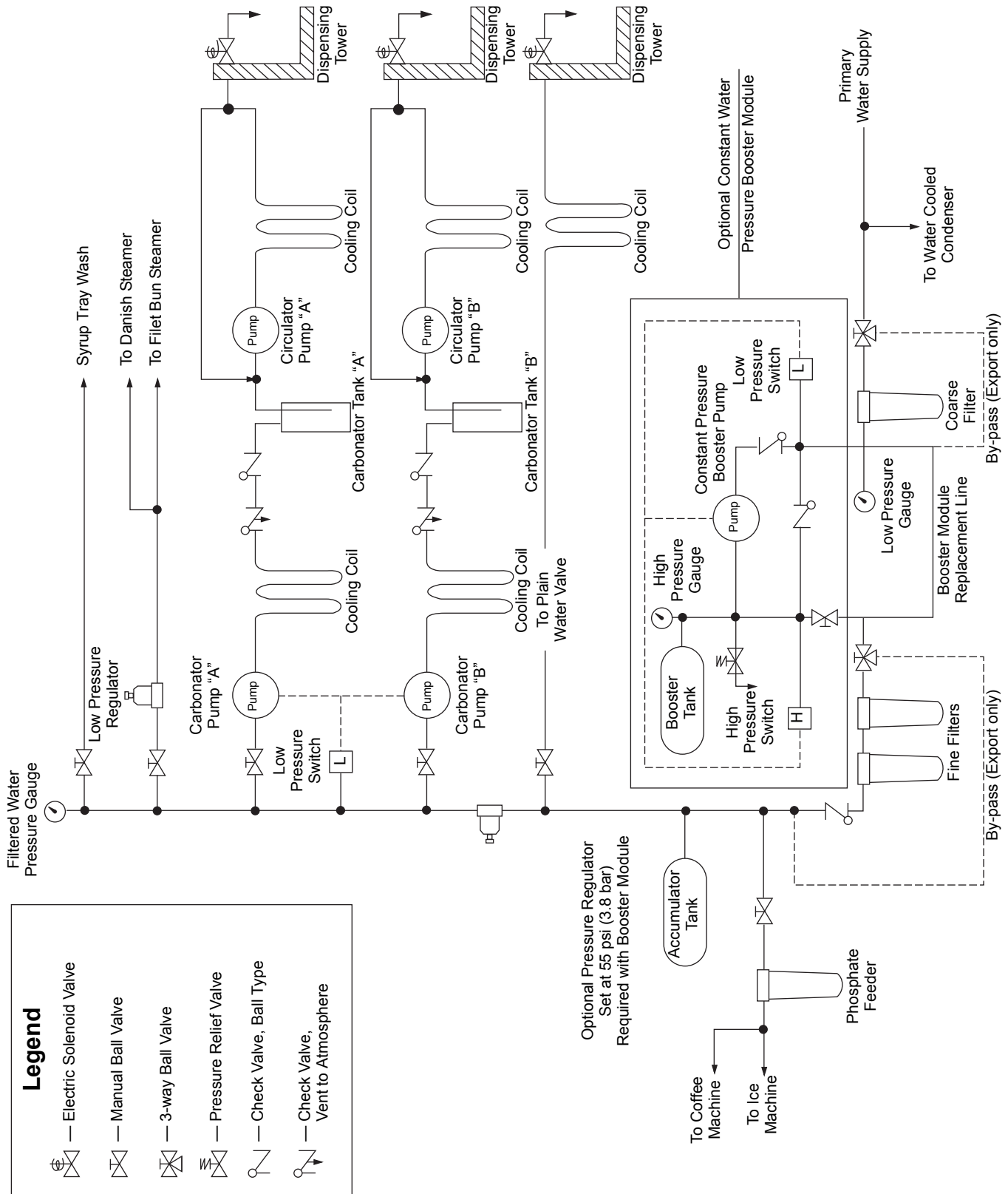

Legend

- Electric Solenoid Valve
- Manual Ball Valve
- 3-way Ball Valve
- Pressure Relief Valve
- Check Valve, Ball Type
- Check Valve, Vent to Atmosphere

CO₂ Gas and Compressed Air Circuit Diagram

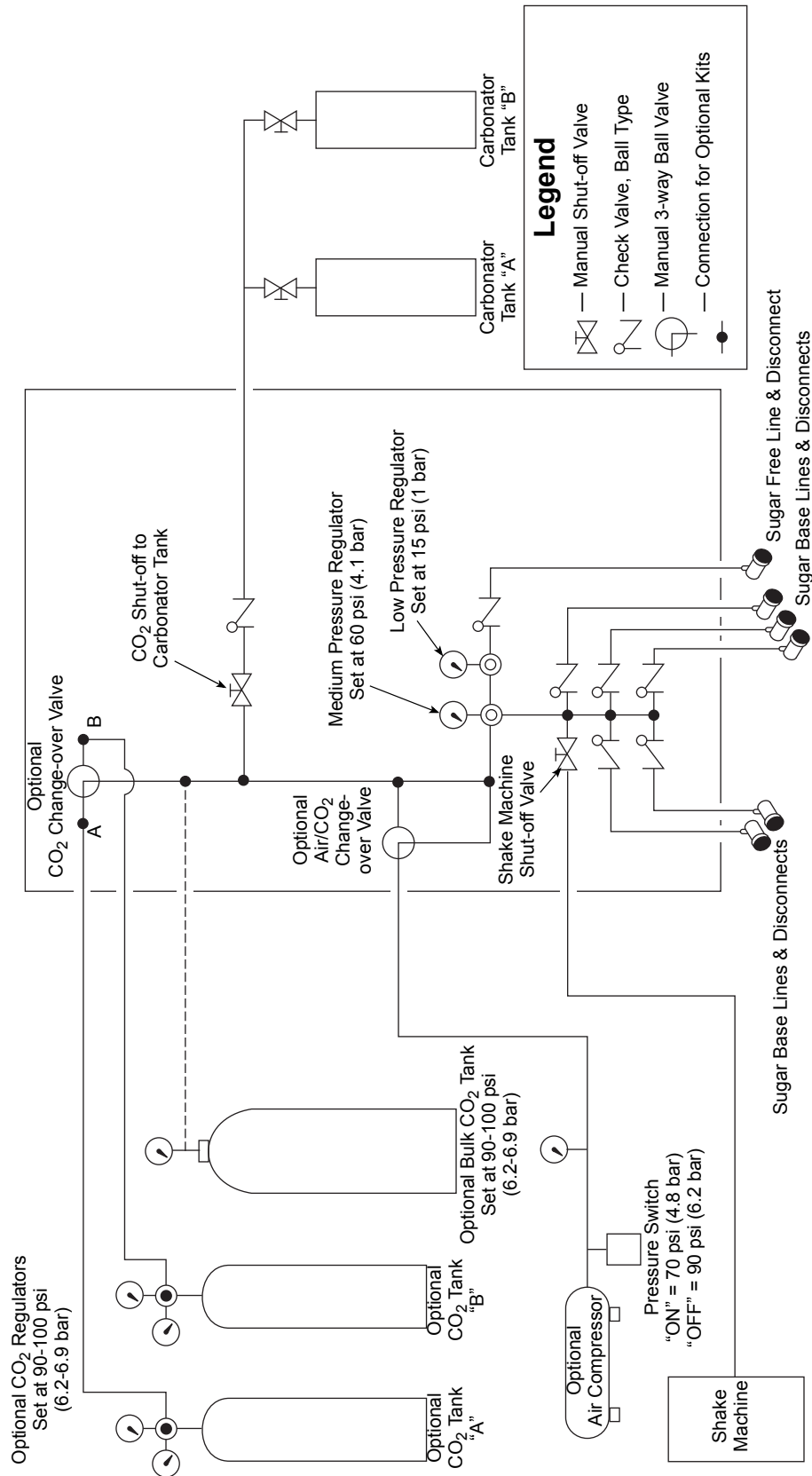

Refrigeration Unit Installation

UNPACKING AND INSPECTING

Carefully inspect the refrigeration unit immediately upon unpacking. Verify the equipment and parts received against the Bill of Lading. Locate all items according to packing list and inspect for possible damage caused by shipping. Notify the appropriate carrier if necessary and contact MBE immediately for replacement of parts if discrepancies exist.

1. The Refrigeration Unit is pre-assembled in the factory and requires a minimum installation. Locate the following parts supplied with the unit.
2. Kit assembly includes:
 - Tab clamps for conduit, syrup and circulating and carbonated water coils
 - Bracket for drain hose and screws for mounting
 - Four 6" legs
 - 6 ft (182.9 cm) drain hose
3. Locate any of the optional Kit Assembly for mounting to match the type of mounting required. Install the kit as noted in the instructions supplied.
4. Record the Model Number, Serial Number and date of installation for future reference, or to be used when ordering parts.

UNIT INSTALLATION OVERVIEW

1. Set unit in place.
2. Connect the circuit electrically. Refer to chart.
3. Connect water supply.
4. Connect the product lines from the Bag-In-Box or tank. See the plumbing diagrams for the tower setup that pertains to your installation.
5. Connect the drain. Locate the drain hose, bracket, and the two screws provided in the installation kit. Attach the drain hose to the water bath overflow tube located on the bottom of the refrigeration unit. Route drain hose to a floor drain.

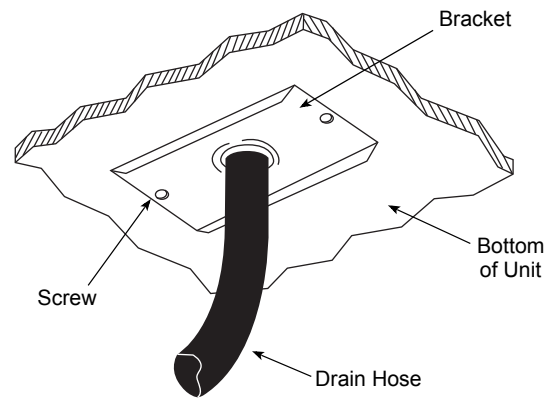

6. Connect the conduit lines. Two carbonated water lines and two product output lines.

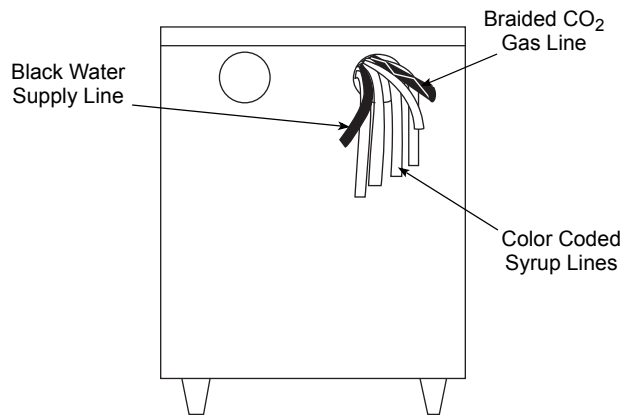

POSITIONING OF REFRIGERATION UNIT

Before proceeding with installation, verify that all requirements for roof mounted Remote Condenser Units have been satisfied (if applicable). Refer to the instructions on installing the Remote Condenser supplied with the unit.

If unit is to rest on floor, locate four 6" (15.2 cm) adjustable legs (optional). Screw and tighten legs into the bottom of the refrigeration unit. Set unit in desired location and adjust legs until unit is level and sturdy. If unit is to be mounted on stand, position stand and secure unit to stand. If unit is to be installed on a wall mount bracket, install wall mount bracket and position unit on bracket at this time. Fasten unit to bracket with bolts provided.

EQUIPMENT PLACEMENT

NOTE: All Refrigeration Units must be mounted on either 6" legs or optional stand.

1. Move the stand/refrigeration unit to the designated area and position it near the wall at a distance of at least 6" (15.2 cm) for air circulation in air-cooled units, or at a distance required by local code.
2. Level the stand/unit by adjusting the leg levelers provide on the legs or stand.
3. If unit is equipped with optional stand, lift the Refrigeration Unit onto the stand. Position the unit in the center of the stand. Be sure to orientate the drain of the refrigeration unit with the drain access hole of the stand. Secure with 5/8"-11 x 1" bolts supplied in kit, use two (2) bolts diagonally. Schedule the plumber and electrician to connect the water supply and electrical service if you have not already done so (refer to Electrical Requirements and Plumbing Requirements for plumbing and electrical requirements listed in these instructions).
4. Mount any optional equipment at this time. Follow the installation instructions for each kit required.

ELECTRICAL CONNECTIONS

 **Caution**

Make sure power supply to unit is turned off.

NOTE: The electrician must refer to the nameplate and wiring schematic on the refrigeration unit for correct electrical requirements. All wiring must comply with all safety codes. Make sure all refrigeration unit power switches are in the OFF position.

1. Remove junction box cover.
2. Route and connect power supply to leads in the electrical junction box at the top rear of the motor compartment.

NOTE: Be sure to connect ground wire(s) to ground screw located on back panel of junction box.

3. Replace junction box cover.

Tower Installation

1. Locate placement of tower on the countertop per restaurant design. Verify counter has been prepared to accept the tower via mounting holes. Refer to tower specs for verification.
2. Mount tower with mounting hardware.

Conduit Installation

PROPER USE OF JOHN GUEST FITTINGS

NOTE: This unit has a compression type tube connector. The following are step-by-step instructions on how to properly use these fittings. For connecting purposes, all connections are furnished with a 3/8" barb connector.

1. Before inserting tubing into a John Guest fitting, be sure end of tubing is cleanly and squarely cut).

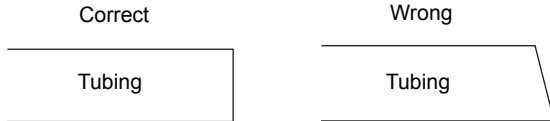

Proper Tubing Cut

2. Lubricate O-ring with water. Insert tubing into John Guest fitting. Push tubing firmly through fitting until it rests against the tube stop in the fitting's main body housing. The tubing is now locked into the John Guest fitting.
3. To release tubing from John Guest fitting, slide collet cover up tube and push in collet. Pull tubing out.
4. Neatly route syrup lines, braided CO₂ gas line and the black incoming water line through the inlet opening on the left side of the refrigeration unit. Do not allow any of these lines to rest on the agitator motor or any other surface that may become hot.
5. Attach the black water supply line to the water filter or a filtered water supply. A 3/8" Barb fitting and tab clamp, reducer bushing and 3/8" male pipe x 1/2" OD John Guest tube adapter are provided in the installation kit for making this connection.
6. Route the numbered syrup lines to the syrup supply (syrup tanks, Bag-In-Box, or bulk syrup). Do not attach lines to syrup supply at this time. Lines will be attached to syrup supply after system is tested for leaks.
7. Attach the braided CO₂ line with swivel nut to a regulated CO₂ supply. Use nylon water provided in installation kit. Note: do not turn ON CO₂ supply to system at this time.

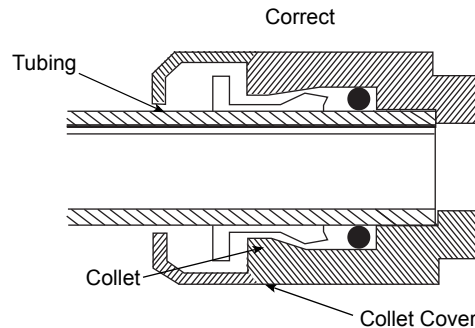
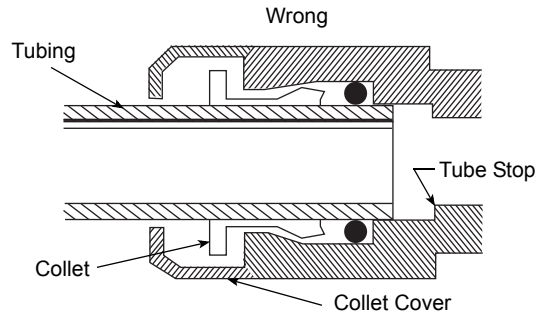

Proper John Guest Fitting Installation

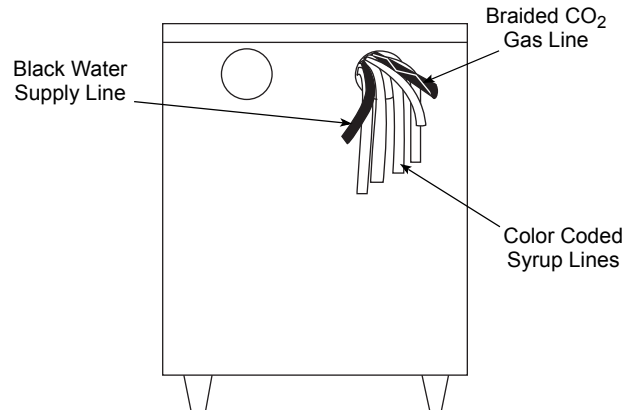

CONNECTING SUPPLY LINES

Pre-installation of towers is required and the appropriate syrup supply must be connected to the corresponding tower. The valves are numbered 1-6, 1-8, or 1-10 from left to right viewing from the front of the tower.

1. For a two (2) tower installation, refer to the Syrup Supply Line Diagram below. The syrup product supply boxes can be positioned on a BIB rack in a convenient location near the soda system.

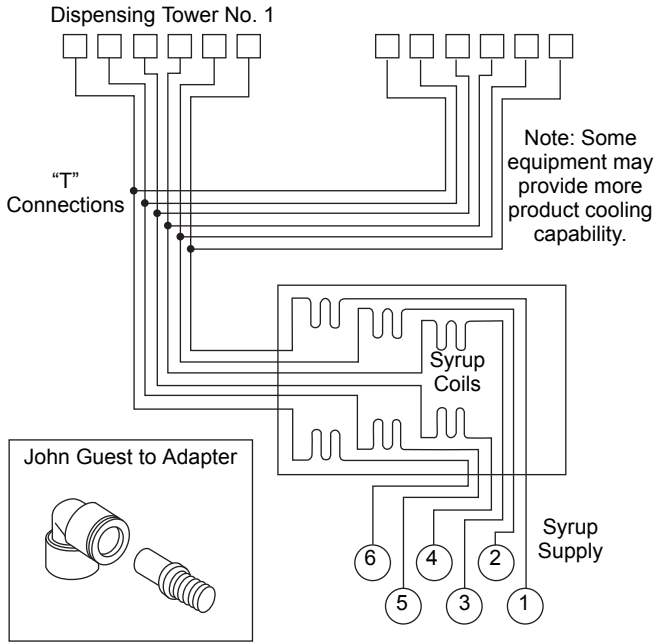

Syrup Supply Line Diagram (Valve #6 Water Only)

NOTE: Refer to the optional equipment component installation instructions for completion (if applicable) of the beverage system. Do not connect the syrup supply at this time.

2. Locate the conduit supply lines for the refrigeration unit. There are four (4) 1/2" (1.27 cm) carbonated water lines marked in sets for the system. Connect the yellow carbonated water supply line (7) to the yellow carbonated water return line (A). Connect the blue carbonated water supply line (8) to the blue carbonated water return line (B). Refer to the Carbonated Water Supply Line Diagram below.

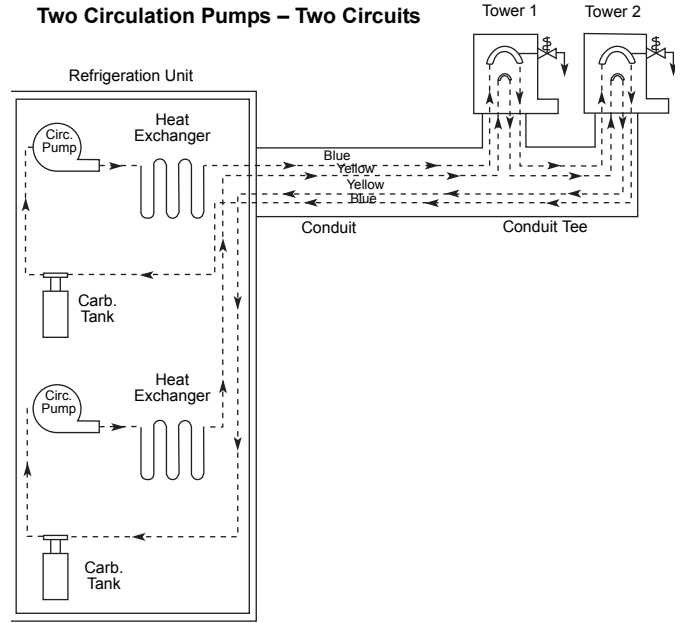

Interlaced Tower

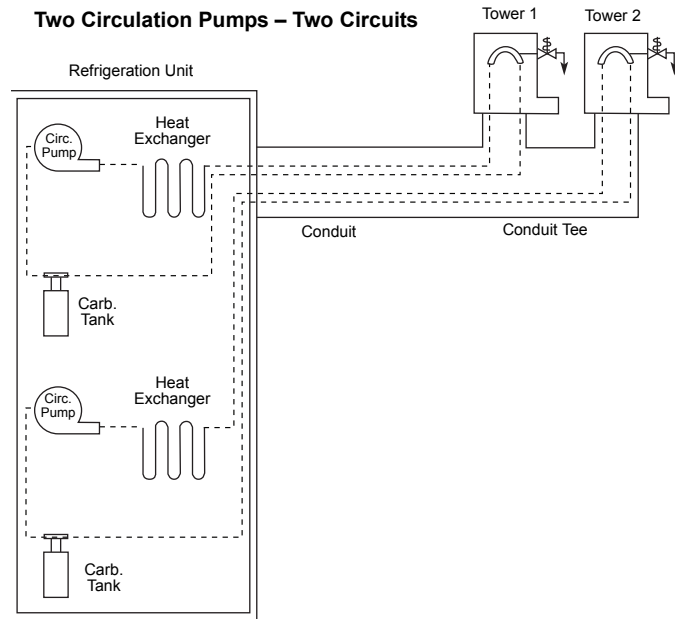

Non-interlaced Tower

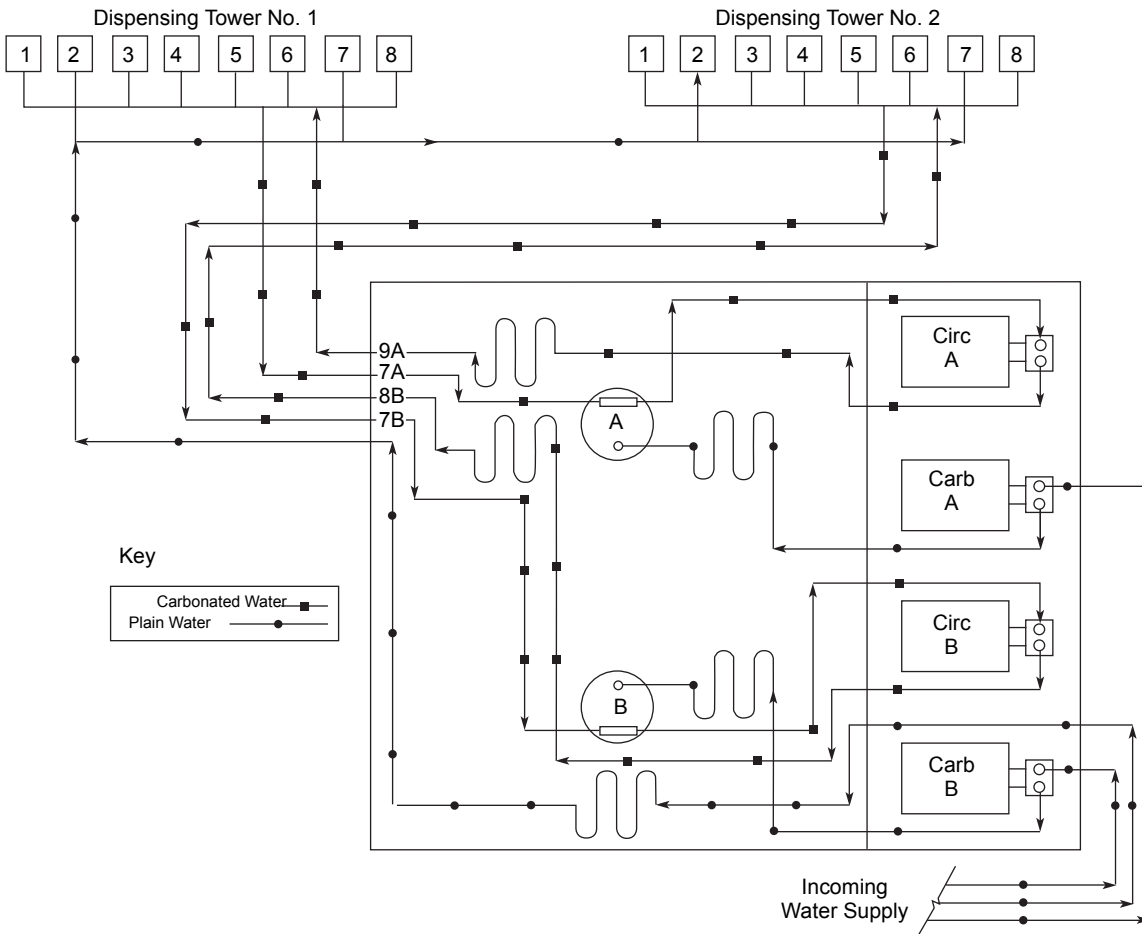

Carbonated Water Supply Line Diagram

3. Locate the #1 and the #8 3/8" (.965 cm) syrup lines. Note: Braided syrup lines located inside the conduit bundle are used to prevent flavor transfer. Braided syrup lines located outside the conduit bundle are used for unsweetened tea or syrup that are like to precipitate (if applicable).
4. Insert the eight John Guest adapters into the elbows on the syrup coils. Note: The 3/8" (.965 cm) and 1/2" (1.27 cm) adapters are supplied for either size conduit.
5. Locate the plain water line(s) in the conduit. Determine the size, either 3/8" (.965 cm) or 1/2" (1.27 cm) and the number (1 or 2). Jumper the line labeled "W". Either connect two splicers for two water lines or use one of the tees supplied to connect the two lines together.
6. Insert the conduit supply lines into the left hand opening of the refrigeration unit. Connect the John Guest fittings requiring the longest tube from the end of the insulation first. Use two tab clamps each per connection. It may be necessary to moisten the lines and fittings before inserting the tubing over the

barbed fitting. Alter the remaining lines to make the routing neat and secure.

7. Connect the CO₂ supply line from the CO₂ tank regulator to the line marked CO₂ in the unit using a 3/8" (.965 cm) by 3/8" (.965 cm) splicer and secure with Oetiker clamps.

Proceed with the Following Tests

- Ensure that overflow tube is firmly seated, not leaking.
- Check conduit for proper support and insulation.
- Cycle carbonator "A" momentarily.
- Cycle carbonator "B" momentarily (if applicable).
- Cycle circulating Motor "A" momentarily.
- Cycle circulating Motor "B" momentarily (if applicable).
- Cycle compressor momentarily.
- Ensure that agitator motor is running.
- Ensure that ice bank control probe is securely attached to evaporator coil.

ROUTING INSULATED CONDUIT

1. Before connecting conduit, evaluate store situation and lay out how the conduit will be routed. Be sure to route conduit away from traffic areas, moving parts, and heat sources.
2. Physically route conduit per evaluated plan. Examine conduit routing and check for neatness, kinks, and interferences.

CONNECTING INSULATED CONDUIT AT THE UNIT

NOTE: List what color line was connected to which product so it can be connected correctly at the towers.

1. Route the conduit to the front opening and into the unit. Cut the insulation back from the lines inside the water bath.
2. Connect the circulating water by connecting one line to the circulating pump outlet line (3/8" barb) and clamp in place. Connect the other line to the bulkhead return fitting located by the agitator motor (3/8" barb) and clamp in place.

CONNECTING INSULATED SUPPLY LINES**Connecting the insulated beverage conduit at the refrigeration unit**

1. Route the Multipar beverage conduit from the refrigeration unit to the dispensing station(s) according to the instructions enclosed with the conduit kit. Always route the conduit in a neat and orderly manner.
2. Insert the Multipar conduit into the outlet opening on the left hand side of unit. Conduit insulation must extend inside of opening in unit for proper operation of equipment.

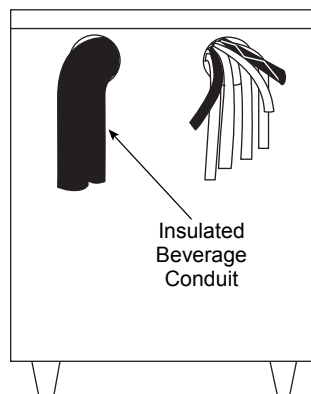

NOTE: Multipar conduit is color coded for easy identification of lines. When making connections always attach lines requiring the longest connection from the insulation first. The remaining lines can be trimmed as required to make the routing neat and secure.

3. Locate the two blue carbonated water lines of the Multipar conduit. Attach one of the blue lines to the tee fitting located on top of the carbonator tank. Attach the other blue line to John Guest elbow fitting on the stainless coil labeled "8".
4. Locate the black plain water line of the Multipar conduit. Attach this line to the elbow fitting on the stainless coil labeled "W".
5. The remaining lines of the Multipar conduit are syrup supply lines and must be attached to the appropriate elbow fittings on stainless steel syrup coils. Note the numbered lines attached to the opposite end of each syrup coil when making connections.

Model 2803 Connections

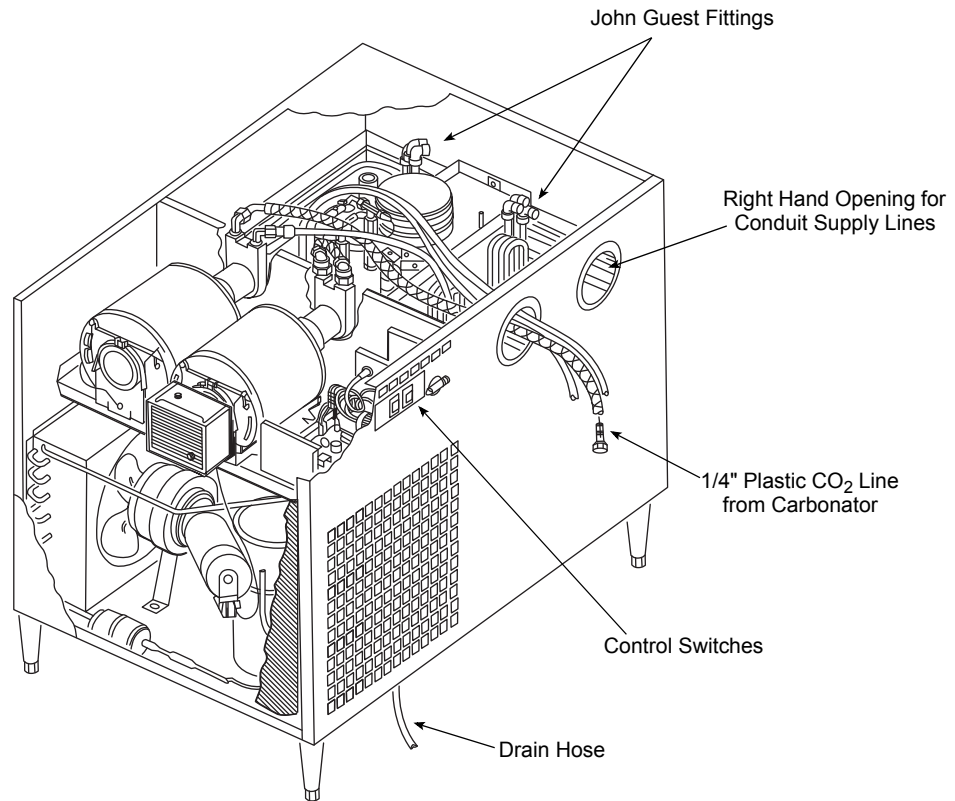

Model 11M Connections

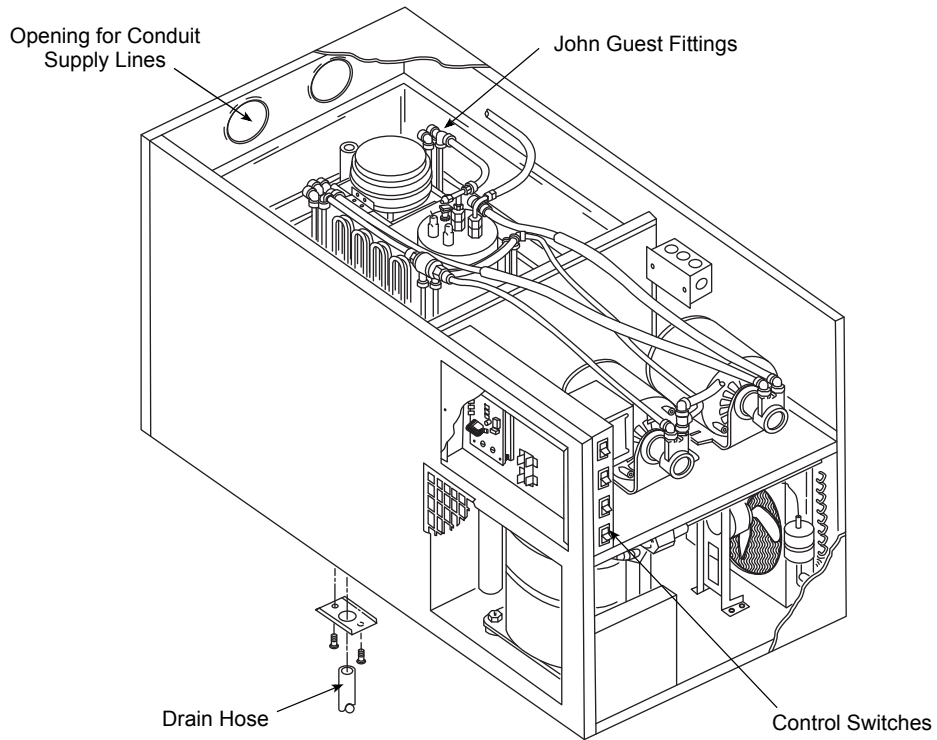

Model 44M Connections

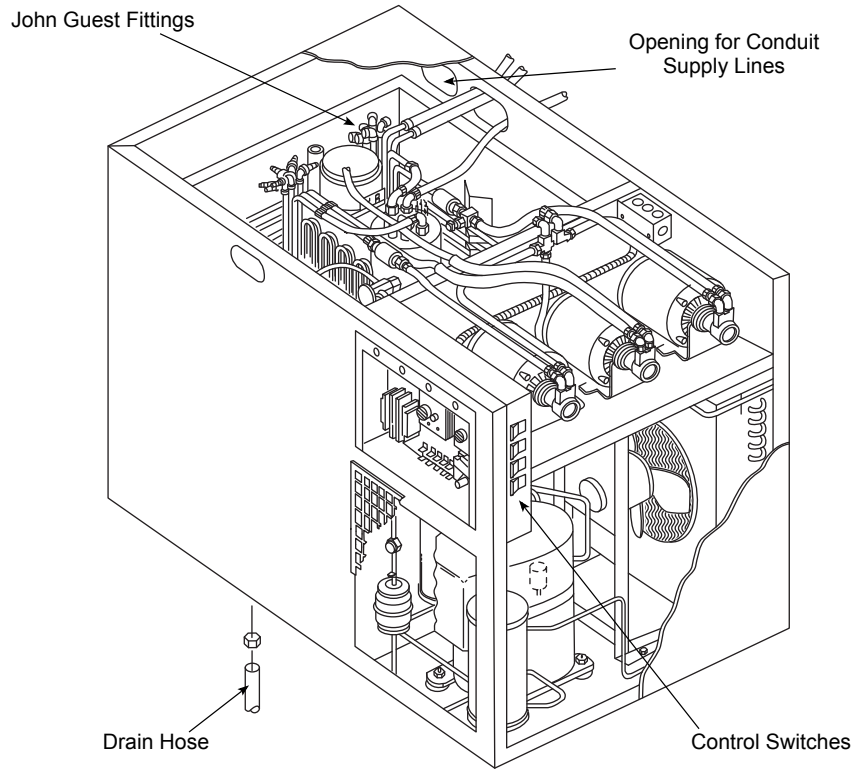

Model 50M Connections

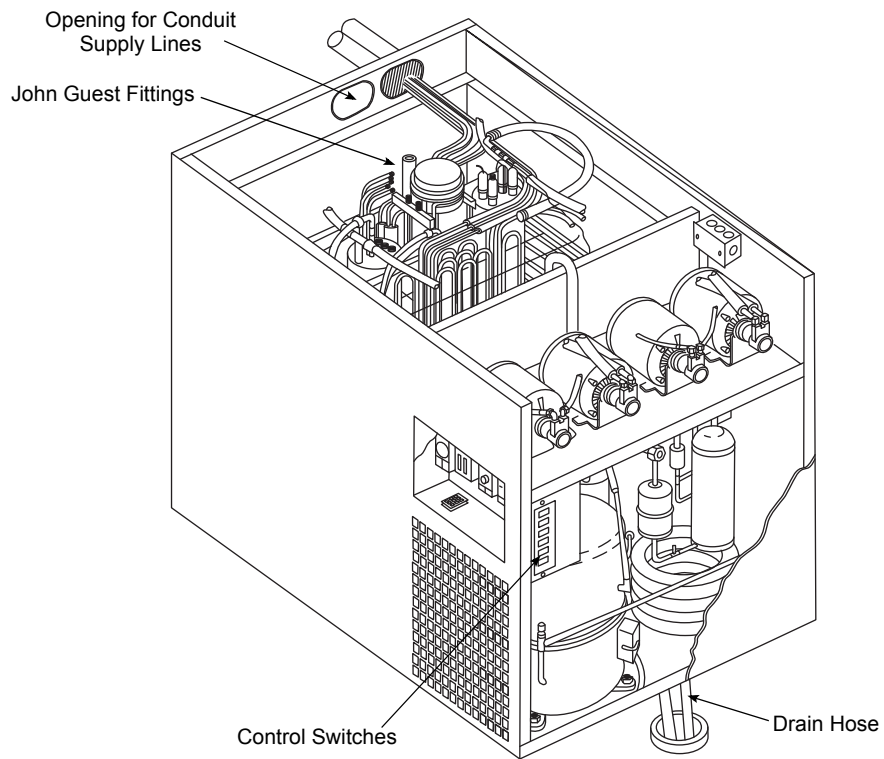

INSULATING CONNECTIONS

1. Make sure all exposed carbonated water and syrup lines are well insulated on towers to conduit, conduit junctions, refrigeration unit to conduits, and drivethrough junction.
2. To insulate the above, use the leftover conduit sections and tape.
3. Cut the conduit sections to fit snugly over the exposed lines and fittings. A little extra time spent doing a thorough job initially will eliminate a call back in several days to make corrections.

NOTE: Do not inject foam material directly on the connections where the tubing connects to the barb fittings or directly on poly tubing.

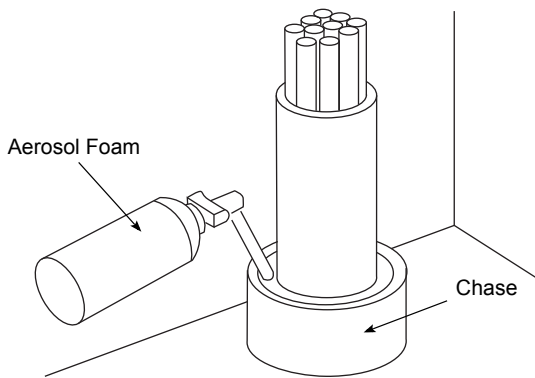

4. The can of foam is to be used to fill the openings between the conduit insulation and the inside diameter of the floor chases. The purpose is to provide an air tight seal at the floor level to prevent foreign matter from entering the chases. Please read the foam manufacturer's instructions carefully. We recommend using the adapter with the right angle extension.
5. Insert the adapter into the openings approximately 1" to 2" (2.5 to 5.1 cm) while depressing the adapter.
6. Move the extension around throughout the area where the foam is to be placed. Do not over fill, allow room for expansion. If the chase opening is too deep insert a section of the leftover conduit insulation in the opening prior to using the foam insulation.

Aeroquip Connection

1. Lubricate male half diaphragm and synthetic rubber seal with refrigerant oil.
2. Thread male coupling to its proper female half by hand to ensure proper mating of threads.
3. Use proper wrenches (on coupling body hex and its union nut) and tighten union nut until coupling bodies "bottom".

NOTE: You must use a wrench on the body to keep the body from turning while tightening the nut with the second wrench. If the body turns excessively, the piercing seal will be damaged.

4. Use proper wrenches to tighten an additional 1/4 turn (90°). This final 1/4 turn is necessary to ensure the formation of a leak proof joint. Alternately, use a torque wrench to tighten the 1/2" coupling to 40 ft-lbs and 3/8" fitting to 11 ft-lbs.
5. Leak check all your connections. If you detect any leaks, repair and recheck.

Condenser and Pre-charged Lines Installation

Before proceeding with installation, verify that all requirements for roof mounted remote condenser units (if applicable) have been satisfied. If unit has a remote condenser, refer to the instructions on installing the remote condenser supplied with the condensing unit and refer to the section on installation of remote refrigeration line sets.

Important

If you are installing a remote unit, there is a refrigeration king valve located behind the compressor. This valve must be back seated prior to starting the compressor. Failure to do so will short cycle and may damage the compressor.

REMOTE CONDENSER REQUIREMENTS

APPROVED CONDENSERS
Multiplex Condenser - TS0895-271
MAC Multi-Pass Condensers

1. Installation and maintenance are to be performed only by qualified refrigeration personnel. These technicians must have EPA certification (USA), are familiar with local codes and regulations, and are experienced with this type of remote refrigeration equipment.
2. As a condition of the warranty, the check, test and start-up procedure must be performed by qualified personnel. Because of possible shipping damage, check both the condensing unit and refrigeration unit(s) for refrigerant leaks.
3. If the refrigeration unit is located on a roll out platform, you must coil up to one round between the back of the stand and the wall. This allows pull out of the refrigeration unit for servicing.
4. If the refrigeration unit is located in a stationary location, you must remove excess refrigeration tubing as described below.

PRE-CHARGED REFRIGERATION LINE REQUIREMENTS**Important**

If you have a MAC Multi-Pass condenser please add three (3) pounds additional charge.

- Both the discharge and liquid remote condensing lines must be kept to a minimum distance for maximum performance. All Multiplex systems are capacity rated to 100 ft (30.5 m) tubing distance between the compressor and condenser. If you have another brand condenser, please add additional charge for the condenser (example: up to three (3) pounds for a MAC condenser).
- Any vertical rise 25 ft (7.62 m) or greater must have a manufactured or installed trap (bend), in the discharge refrigeration line from the compressor to the remote condenser. A trap is necessary for every additional 25 ft (7.62 m) vertical rise. When excessive vertical rise exists, this trap allows oil to reach the condenser and return to the compressor.
- The easiest method to create a trap is to bend the tubing (smoothly, no kinks) into the trap form.

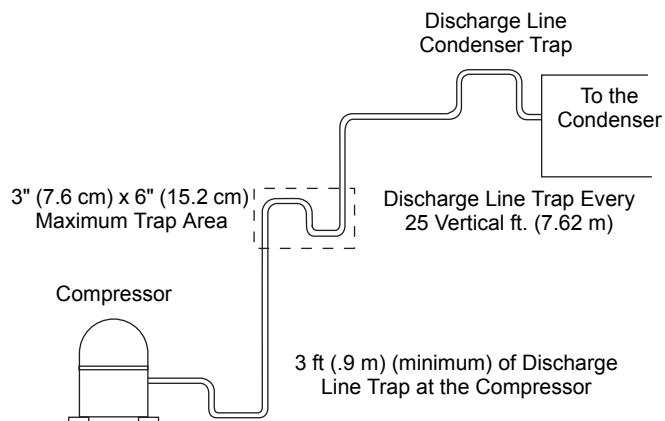

- The trap(s) must be of minimum height of 3" (7.6 cm) and a width of 6" (15.2 cm) to minimize oil accumulation. The traps can also be bent out of the refrigeration tubing. Carefully bend the tubing down 12", and then sweep the tubing back up.
- It is critical that the Multiplex remote condensing line size specifications for the specific model be maintained. The specifications are 1/2" discharge and 3/8" liquid lines.

INSTALLING THE MULTIPLEX REMOTE CONDENSER

The Multiplex remote condensing units have a 208-230 Volt, 50/60 HZ, 1 PH fan motor that includes a permanent split capacitor and internal overload protection. The electrical wires from the refrigeration unit wire to the condenser. The electrical installation must be in accordance with local codes, National Electrical Code and regulations.

- Determine a position for installation that will allow access for maintenance and is free from obstruction. Verify hot air discharge from other condensers does not interfere with the inlet of this condenser.
- Install the four legs to the sides of the condenser using the mounting bolts provided.
- The General Contractor or Owner must secure two treated lumber 4" x 4" x 36" (or longer). You may then mount the remote condenser to the treated lumber.
- The General Contractor or Owner must install a 3" pitch pot in the roof. Then seal for weather protection.

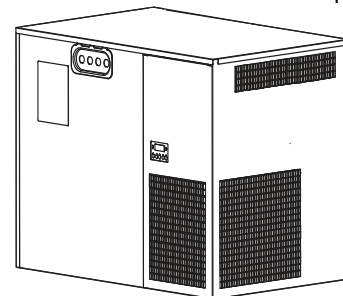
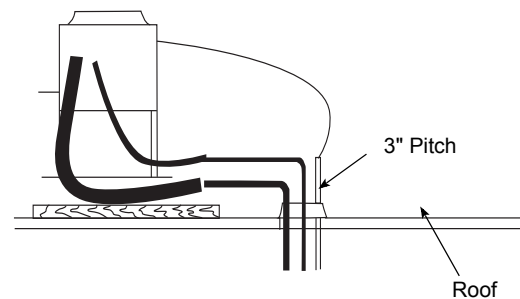

- Locate the pre-charged refrigeration lines shipped with the system. These lines must be a correct length for the building design. Avoiding any kinks, neatly route these lines from the remote condenser to the refrigeration unit. Excess refrigeration tubing must be handled in one of two ways. When coiling the excess tubing, make sure the inlet to the coil is at the top of the coil and the exit is the bottom of the coil. There can be no more than one turn to the coil. If you have more tubing, you must cut out the excess before connecting the ends. When cutting the tubing, you must first evacuate the refrigerant (line sets have a positive refrigerant holding charge of two to three ounces). After shortening and welding the tubing together again, you must vacuum the tubing to 250 microns. Then recharge the tubing with the appropriate refrigerant at 4 ounces per length of tubing.

⚠ Caution

Excess refrigeration tubing must be properly cared for before being connected to either the remote condenser or the refrigeration unit.

CONNECTING THE PRE-CHARGED REFRIGERATION LINES

NOTE: Before connecting the pre-charged refrigeration lines, the refrigeration unit must be properly located, leveled, and the water bath filled 1" (2.5 cm) below the installed drain pipe.

1. Attach low side gauge set to service port on each line set to verify positive pressure within the line set.

NOTE: If for any reason the lines are damaged and/or leaking or the lines no longer charged, refer to "How To Re-charge the Line Sets". If the line set is too long for the application, refer to "How to Shorten the Line Sets" in Section 3.

2. Always make the connections at the condenser first, using the end of the pre-charged lines with the valve ports.
3. Connect the condenser side with the quick connectors (discharge and liquid) up to condenser. Refer to the section titled "Aeroquip Connection" in these instructions.
4. Connect the refrigeration unit side with the quick connects (discharge and liquid). Make sure to provide a discharge trap at back of refrigeration unit, or bend discharge line down 12" and then up smoothly (no kinks) to provide a trap.
5. If a low refrigerant charge is detected, recover and recharge the system adding the unit name plate charge.
6. Repair any damages to the line sets before proceeding.

Testing

TESTING CO₂ CIRCUIT FOR LEAKS

It is advisable to test the system for leaks before turning **ON** the water supply to the carbonator and connecting the syrup tanks. If a leak does exist, it will be easier and faster to make any correction.

1. Turn **ON** the CO₂ supply and adjust the primary regulator to 90 psi (6.2 bar).
2. Position the CO₂ tank changeover valve handle (if applicable) toward this regulator.
3. Move the air/CO₂ changeover valve to the CO₂ position (if applicable).
4. Allow the CO₂ gas to enter the system.
5. Wait for 2 or 3 minutes before turning **OFF** the CO₂ tank valve. This will allow the lines to expand under pressure.

6. Turn **OFF** the CO₂ tank valve. Observe the pressure on the high pressure gauge (not the 90 psi [6.2 bar] operating gauge). The needle may drop approximately 1 psi (.09 bar), but must remain constant and not lose pressure. Wait for several minutes.

If pressure continues to fall, this indicates there is a leak in the system which must be corrected.

The greater the leak, the faster the pressure will drop. The smaller the leak, the slower the gauge will drop.

It may be necessary to use a soap solution at all connections to locate a very small leak.

CO₂ gas must be present on all valves of the tower(s)

NOTE: All soap solution must be rinsed thoroughly from tubing upon completion of testing.

TESTING SYRUP CIRCUIT (5 GALLON TANKS ONLY)

Before connecting the syrup tanks to the system, the syrup circuits must be tested for leaks with CO₂ gas.

1. Connect an empty syrup tank to pre-mix syrup circuits.
2. Connect one of the CO₂ gas quick disconnects to this tank. Allow the tank to fill with CO₂ gas.
3. Observe the pressure of the primary CO₂ tank regulator (not the 90 psi [6.2 bar]).
4. Allow the CO₂ tank pressure to remain **ON** for a few seconds. This will allow the lines to expand to operating conditions.
5. Turn **OFF** the CO₂ tank cylinder.
6. Check all connections from the syrup tank through the connections in the water bath area to all fittings at rear of tower.
7. Check syrup circuitry on the tower by activating the valve.
8. Follow the same procedure for the diet pre-mix beverage circuit.

If no leaks are found in the syrup circuits and the carbonated water circuit, the system is ready to be insulated and placed in operation.

Preparing Ice Bank

BUILDING AN ICE BANK

1. At this time, fill the unit water bath tank to the top, or within 1/2" (1.3 cm) of the top minimum, of the overflow tube. Use a garden hose or another water supply to do this.

NOTE: A manual fill valve is incorporated into the water circuit to the carbonator tank. This valve can be used to manually add water lost for any reason. Do not leave this valve ON constantly, only use it for filling and topping off. The water bath must be drained, flushed, and refilled every six months.

2. Turn ON the switch labeled "Refrigeration". Allow unit to run for about 15 minutes before proceeding to step 3.
3. Turn ON the switch labeled "Agitator".

Note: Turn this switch OFF to perform any operations in the water bath area.

With water bath water temperature of 65°F (18°C), ice must begin to form on the evaporator coils in approximately 2 hours. The unit will build a full ice bank in approximately 4 to 6 hours (depending on ambient water temperature).

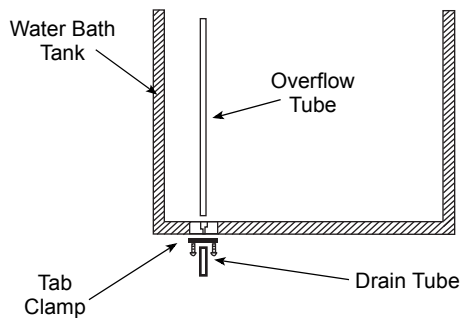

4. Before turning on the carbonator or circulator switch, verify that the pump box assembly has been mounted and connected to the unit and the appropriate syrup and water has been supplied.
5. Turn on the main water supply to the booster assembly. Verify the booster is plugged in and that the accumulator tank valve is open. (If the system has an optional "Out-of-Syrup" device, verify that it is unplugged.)
6. Verify the pump is running. Place the valve on the right side of the pump box in the purge position until all air bubbles have passed through the line. Turn the valve back to "dispense". Plug the Out-of-Syrup device power cord into an appropriate wall outlet at this time (if supplied).

NOTE: Verify that the pump box holding tank is full before proceeding.

7. Turn on the circulator and carbonator switches. The carbonator must run for approximately 1 to 3 minutes and shut off. The circulator must run continuously. Verify that water is returning to the water bath through the return bulk head fitting.

Important

Wait until a thin layer of ice has begun to form on the evaporator before proceeding any further.

8. Go to the tower(s) and brix the valves. Using a syrup separator and volume cup, adjust the flow rate of the carbonated water to two fluid ounces per second. Then, using the separator and a brix cup, adjust the syrup flow rate for a ratio of carbonated water to syrup to 5 to 1.

Installation Checklist

- Check all fittings and conduit attachments for leaks. Check all insulated connections to make sure that they are sealed.
- Observe the pump operations for leaks.
- Check the water bath for full ice bank.
- The stabilized water bath operating temperature must be maintained at 33°F (.6°C) to 35°F (1.7°C).
- Close water bath feeder valve completely.

THIS PAGE INTENTIONALLY LEFT BLANK

Section 3 Operation

Typical System

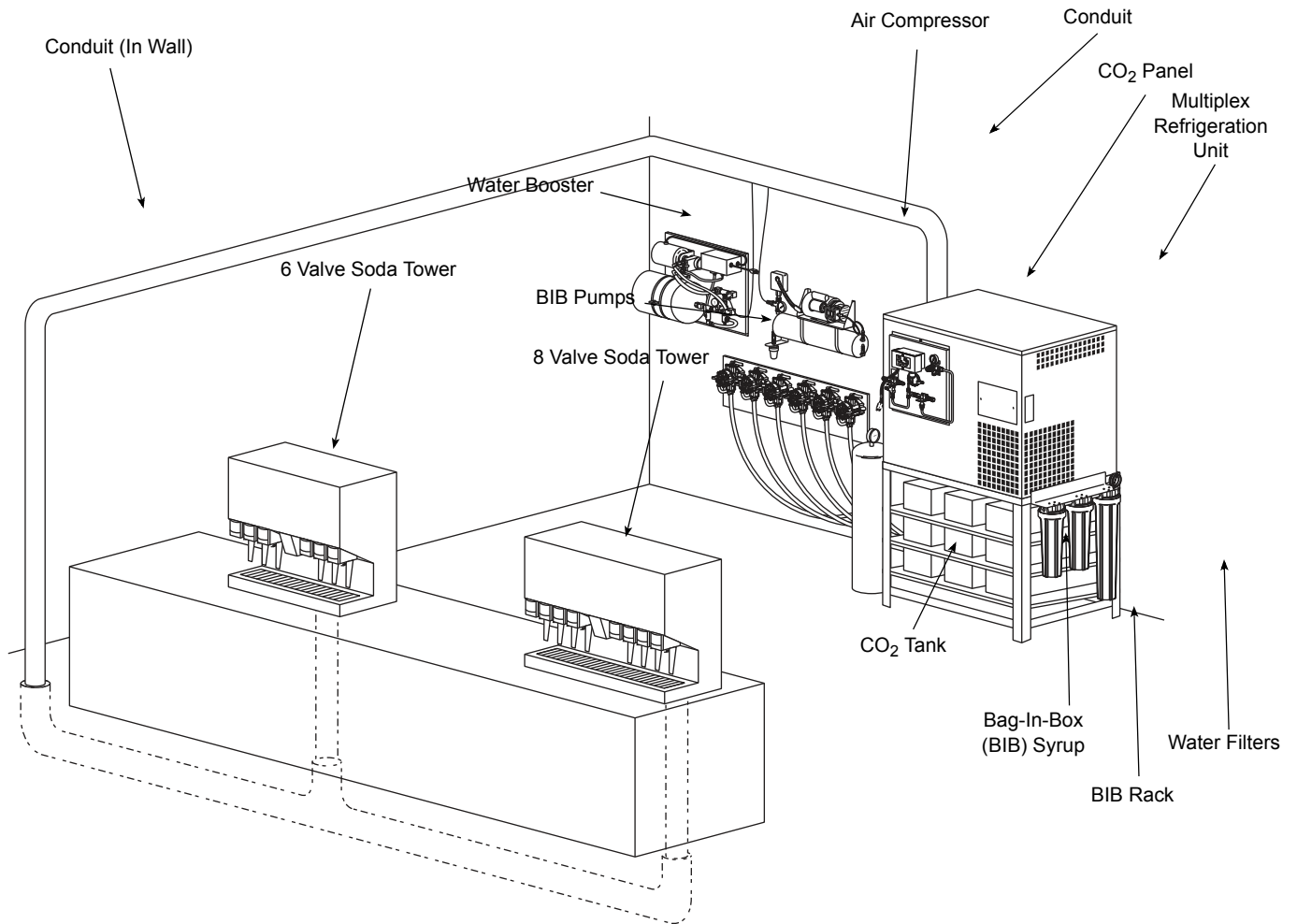

How the Multiplex Works

The Model 2803 is a 1/3 HP refrigeration unit that will provide pre-mix carbonated beverages and chilled carbonated water for up to 6 gal (3 L) of syrup/day or 280 drinks/day (2,000 gal/yr) with a 40 ft (12 m) maximum conduit length. This is a remote refrigeration unit that derives its peak draw capacity from the reserve ice bank produced from a capillary tube refrigeration system. This system is controlled to cycle ON and OFF by the operation of the ice bank control. The sensing bulb that controls the ice bank is located on an adjustable bracket in the water bath.

The Model 11M is a 1/2 HP refrigeration unit that will provide premix carbonated beverages and chilled carbonated water for up to 12 gal (45 L) of syrup/day or 560 drinks/day (4,000 gal/year) with a 100 ft (30 m) maximum conduit length. This is a remote refrigeration unit that derives its peak draw capacity from the reserve ice bank produced from a capillary tube refrigeration system. This system is controlled to cycle ON and OFF by the operation of the ice bank control. The sensing bulb that controls the ice bank is located on an adjustable bracket in the water bath.

The Multiplex Model 44M is a 1 HP refrigeration unit that will provide pre-mix carbonated beverages and chilled carbonated water for up to 32 gal (121 L) of syrup/day or 1,400 drinks/day (11,500 gal/yr) with a 250 ft (80 m) maximum conduit length. This refrigeration unit is a remote refrigeration unit that derives its peak capacity from the reserve ice bank produced from a capillary tube system. This system is controlled to cycle ON and OFF by the operation of the ice control. The sensing bulb that controls the ice bank is located on an adjustable bracket in the water bath.

The Multiplex Model 50M 2.2 HP Pre-mix refrigeration unit will provide pre-mix carbonated beverages and chilled carbonated water for up to 42 gal (159 L) of syrup/day or 2,000 drinks/day (15,000 gal/yr) with a 350 ft (107 m) maximum conduit length. This refrigeration unit is a remote refrigeration unit that derives its peak capacity from the reserve ice bank produced by the operation of the compressor. This system is controlled to cycle ON and OFF by the operation of the ice bank control. The sensing bulb that controls the ice bank is located on an adjustable bracket in the water bath.

Differences Between the TS & SS Units

The Model 50M and 44M have 2 different sets of part numbers. Starting in 2007 the Model 50M part numbers no longer begin with a SS and now begin with a TS. The following shows you how to tell the difference between the TS version of the Model 50M and 44M and the SS.

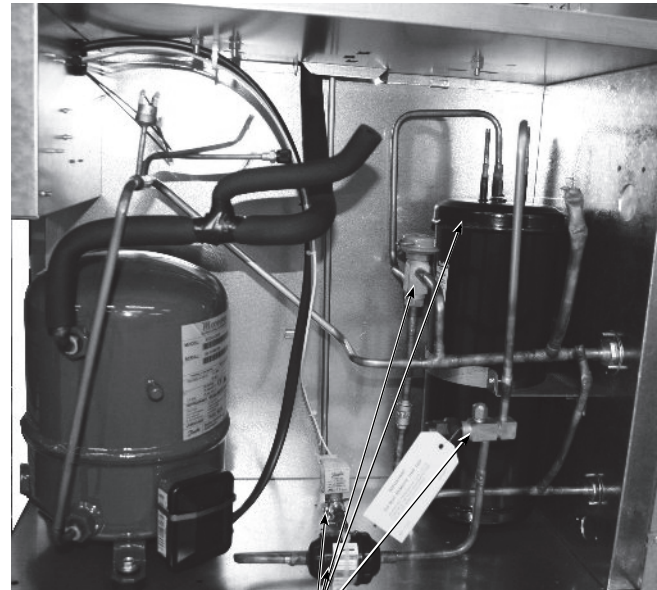

- The TS uses common components from Manitowoc ice makers to assist in product and parts availability.

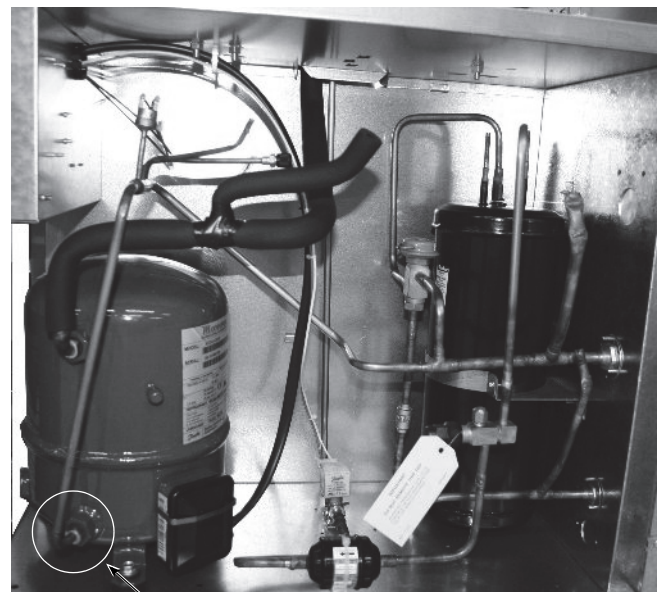

- The TS compressor is mounted with bolts instead of studs.

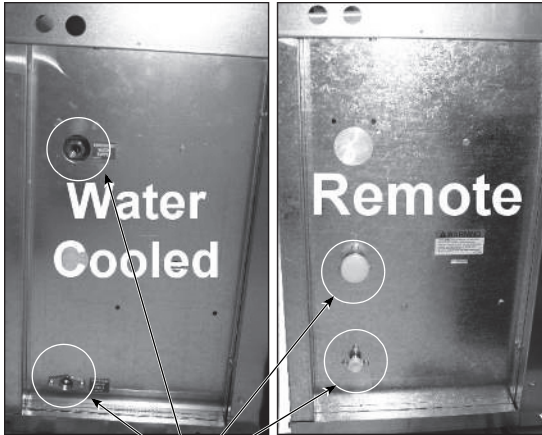

- TS remote and water-cooled back panel connections are offset to protect fittings.

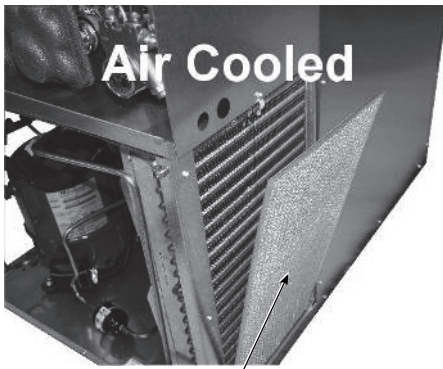

- TS air-cooled condenser comes standard with a filter.

WATER MANIFOLD TS

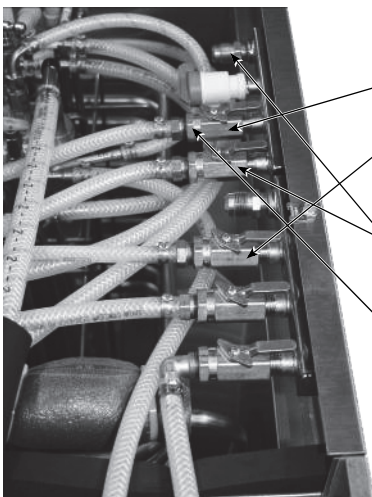

Two Stainless Steel log style manifolds

- One regulated supply for carbonator pumps.
- One unregulated supply for non-carb drinks and water bath fill.

Other Connections

- Connections are made in the water bath compartment.
- Separate plain water manifold eliminates need to plug off during installation

ELECTRICAL TS

- Electrical compartment has been moved up on the unit to eliminate water intrusion potential from the pump compartment.
- All components are now 208/230V. This eliminates the need for a neutral wire.

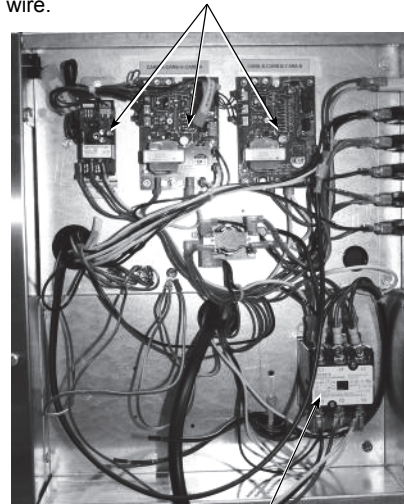

- New unit has service connections in the electrical compartment. Allows more room to work and more reliable connection.

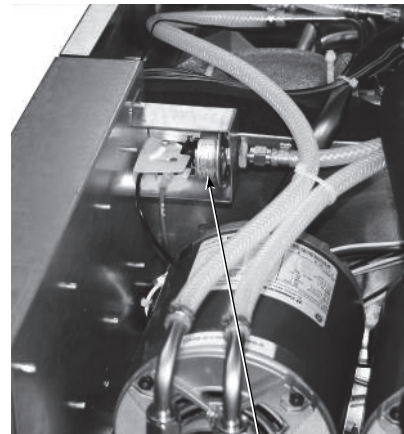

- Pump protection switch has been moved to the pump compartment to eliminate potential leak point in electrical compartment.

WATER BATH ACCESS SS

- Has a round hole in the front and back panels with no edge trim to protect lines.

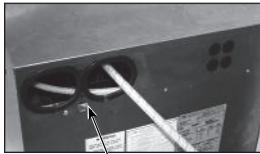
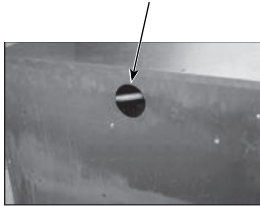

- End panel has two ovals in the rear of the panel with edge trim to help protect conduit lines.

WATER BATH ACCESS TS

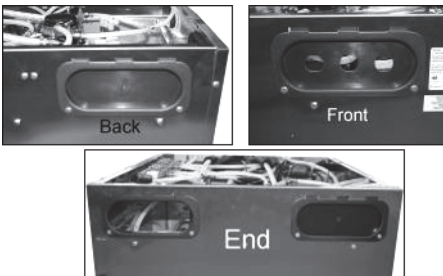

- All panels have large oval access holes with interchangeable covers.
- Front panel has 3 hole cover for water and CO₂ line routing.
- Back panel has solid cover.
- End panel has one open cover and one solid cover.
- Open cover provides wide ledge for conduit line protection.

SERVICE ACCESS SS

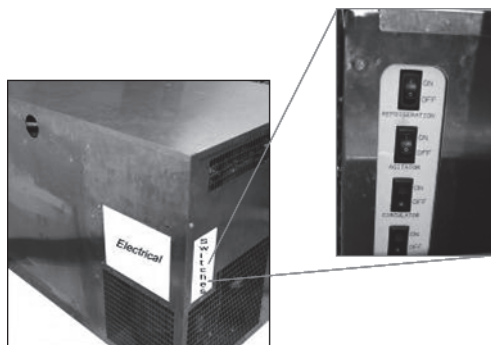

- Front panel was solid and did not allow easy access for service.
- Switch panel was mounted flush to end panel.

SERVICE ACCESS TS

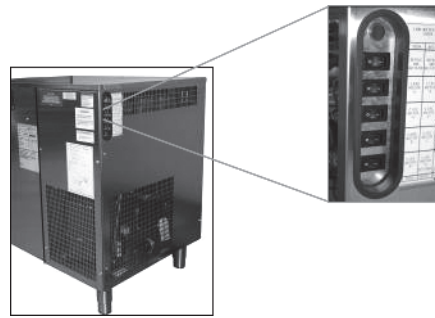

- Front panel is split to allow front access to the compressor compartment.
- Switches are recessed and the edge has trim panel to protect fingers from sheet metal edges.

Start-up (Non-ERC)

PLACING EQUIPMENT IN OPERATION

Before placing equipment in operation, verify that all requirements for roof mounted Remote Condenser Units (if applicable) have been satisfied. Refer to the instructions on installing the Remote Condenser.

1. Fill the refrigeration unit water bath tank with water to within 1/2" (1.27 cm) of the top of the overflow tube.
 2. Open the manual water shut-off valve to the water cooled condenser (if applicable).
 3. Turn ON the rocker switch labeled "Refrigeration" to begin building an ice bank.
 4. Turn ON the rocker switch labeled "Agitator".
- NOTE: On TS units 3 & 4 are combined into 1 switch.
5. Ice will begin to form on the evaporator coils in approximately 2 hours.
 6. The refrigeration unit will build an ice bank in approximately 4 to 6 hours.
 7. If optional CO₂/Water Control Panel has been installed on the refrigeration unit, refer to the installation instructions for operation and testing the circuits for leaks.
 8. The carbonation circuits "A" and "B," as well as the syrup circuits must be checked for leaks and possible cross circuits before turning ON the water supply to carbonator pumps.
 9. Turn on main water supply. Set incoming regulator to 55 psi on the CO₂ panel; 25 psi for the Model 11M root beer system's internal regulator (must be lower than CO₂ supply pressure). Once water is supplied

to the unit, air needs to be purged from the carbonator tank. Do so by lifting press relief valve tab until water comes out of relief valve.

10. Turn on main CO₂ supply. Set regulator initially to 90 – 100 psi. For the Model 11 Root Beer system, set regulator initially to 26 psi; it can be raised incrementally to 30 psi if there is excessive foaming.
11. Set bag-in-box syrup tank push pressure CO₂ regulator to 65 – 70 psi. For the Model 11 Root Beer system, set push pressure CO₂ regulator to 35 – 40 psi.

PLACING THE CARBONATION SYSTEM IN OPERATION

1. Open the CO₂ gas supply valve at CO₂ tanks or bulk tank. Adjust the CO₂ pressure to 90 psi (6.2 bar).
2. Open relief valve on top of the carbonator tank for 4 seconds to bleed off air in tank.
3. Turn ON the water supply to unit.
4. Turn ON the switch labeled “Carbonator Pump”. Allow carbonator to run and cycle OFF.
5. Activate all valves until a smooth, continuous flow or carbonated water and non-carbonated water appear at the valves.
6. Turn ON switch labeled “Circulator”.
7. Allow at least 1 hour before proceeding to calibration instructions. You may complete the sanitizing instructions during this period.

Sequence of Operation

PRE-MIX REFRIGERATION UNIT

Ice Bank Is Required

1. Check water bath for full ice bank.
2. The stabilized water bath operating temperature must be maintained at 33°F (0.6°C) to 35°F (1.7°C).

The following is a sequence of operations for the Multiplex Pre-mix Beverage equipment.

1. Once a drink is dispensed, the following will occur:
 - A. For a Syrup Tank System, the Pre-mix syrup is manually mixed at the store. Pre-mix beverage is then transferred to a holding tank for supply to the Multiplex system.

- B. For a Bag-In-Box System, pre-mix syrup is drawn from a Bag-In-Box by means of a gas driven syrup pump.
2. The brix pump mixes a 5:1 ratio pre-mixer syrup and water into a 3 gallon holding tank located in the pump box (the 3 gallon tank is vented to atmosphere).
3. The carbonator pump (stainless) pulls the 5:1 pre-mix out of the 3 gallon holding tank and injects it into the pre-mix carbonator tank where the CO₂ pressure is 35 psi (2.4 bar) on the tank.
4. The circulator pump runs continuously and circulates water bath water through the conduit to provide cooling for all drinks.

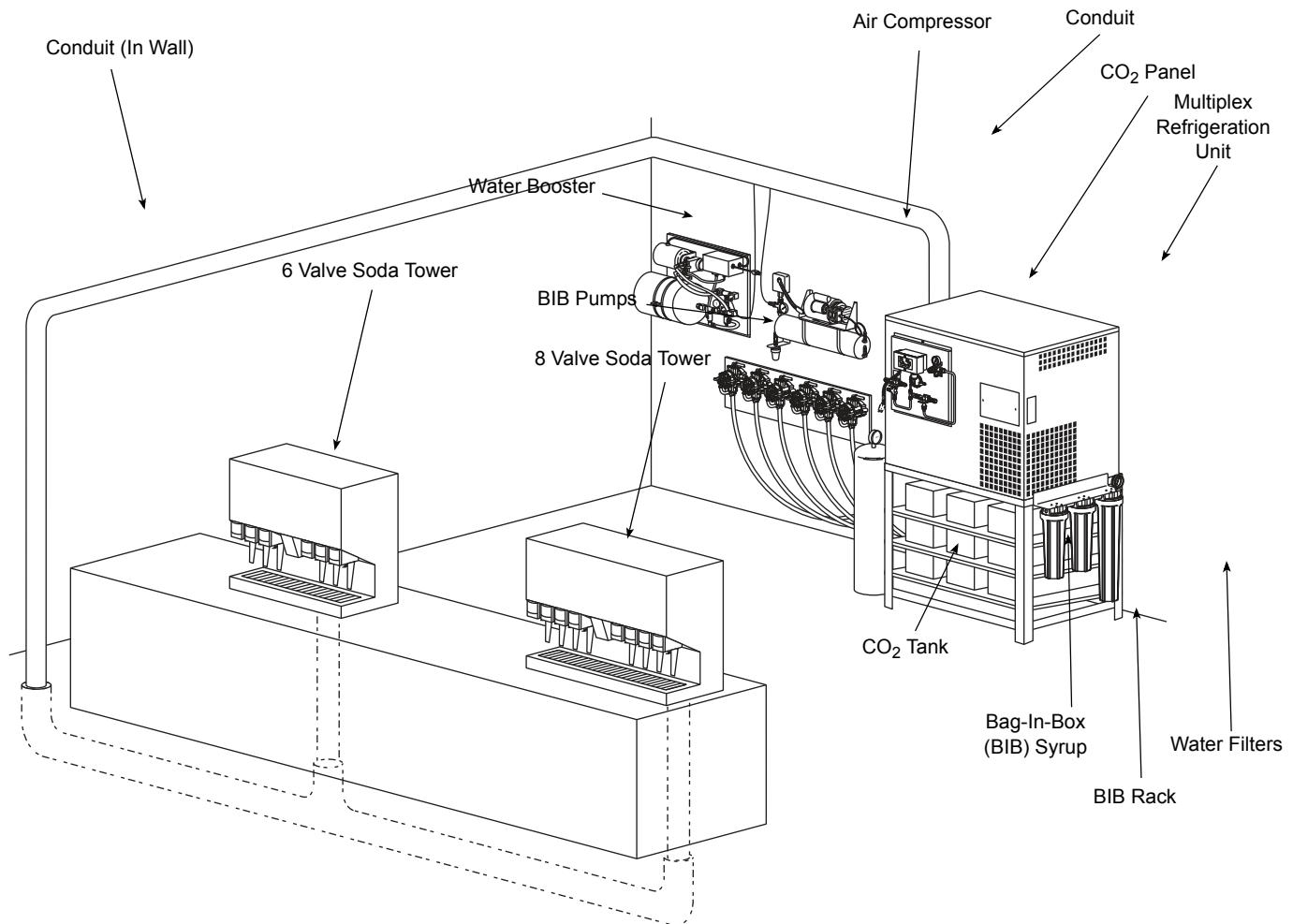

Multiplex Pre-mix Beverage System Operation and Layout

Equipment Setup and Close Procedure**EQUIPMENT SETUP PROCEDURE**

1. Ensure that all valve nozzles are attached to the valves.
2. Observe pressure of CO₂ high pressure tank of 500 psi (34 bar) or more, or bulk CO₂ tank of 150 psi or more. Primary regulator set at 90 psi (6 bar) and the secondary regulator set at 35 psi (2.4 bar).
3. Observe the control panel to verify that all pressure gauges are set at correct operating pressures.
4. Check the syrup tanks to make sure a sufficient number of tanks are connected in series to satisfy business volume.
5. Clean syrup inlet and outlet quick disconnects at the same time tanks are replaced. Rinse disconnects in clean potable water.

EQUIPMENT CLOSE PROCEDURE

1. Clean the underside of the dispensing tower around the nozzle area with a clean damp towel.
2. Pour at least 60 oz (1.8 liters) of warm water down the drain openings.

THIS PAGE INTENTIONALLY LEFT BLANK

Section 4 Maintenance

Sanitizing

BEVERAGE SYSTEM CLEANING

⚠ Warning

Flush sanitizing solution from syrup system.
Residual sanitizing solution left in system could create a health hazard.

⚠ Warning

When using cleaning fluids or chemicals, rubber gloves and eye protection must be worn.

Sanitize the beverage system at initial start-up as well as regularly scheduled cleaning. The drain pan must be in place under soda valves, to carry away detergent and sanitizing agents that will be flushed through valves.

BAG-IN-BOX SYSTEM SANITATION

The procedure below is for the sanitation of one syrup circuit at a time. Repeat to sanitize additional circuits.

You will need the following items to clean and sanitize the Bag-in-Box (BIB) beverage system:

- Three (3) clean buckets
- Plastic brush or soft cloth
- Mild detergent
- Unscented bleach (5% Na CL O) or Commercial sanitizer
- Bag-In-Box bag connector

1. Prepare the following in the buckets:

- Bucket 1 — warm to hot tap water for rinsing.
- Bucket 2 — mild detergent and warm to hot water.
- Bucket 3 — mix a solution of unscented bleach (5% Na CL O) or commercial sanitizer and warm to hot water. Mixture should supply 100 PPM available chlorine (1/4 oz. bleach to 1 gallon water).

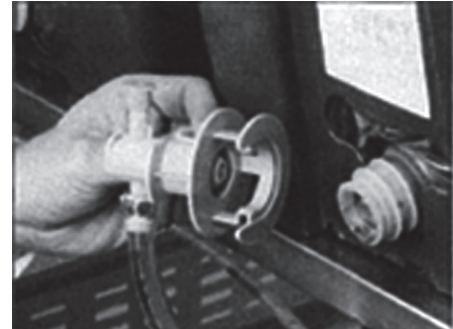

2. Disconnect the "syrup-line side" of the BIB connector.

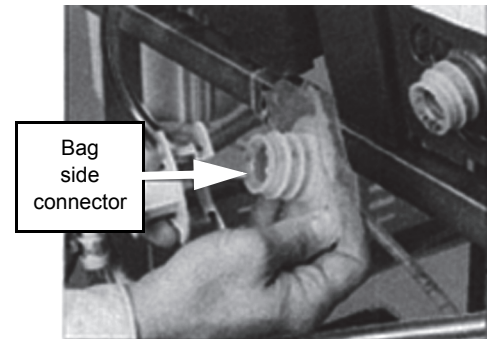

3. Rinse connector with warm tap water.

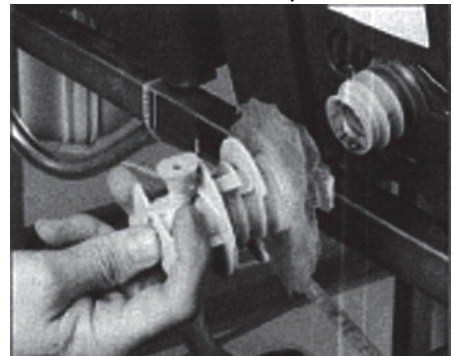

4. Connect syrup connector to BIB connector and immerse both into Bucket 1. A "bag-side" connector can be created by cutting the connector from an empty disposable syrup bag.

5. Draw rinse water through system until clean water is dispensed. Most beverage valves allow the syrup side to be manually activated by depressing the syrup pallet.
6. Connect Bucket 2 to system.
7. Draw detergent solution through system until solution is dispensed.
8. Repeat steps 2-7 until all syrup circuits contain detergent solution.
9. Allow detergent solution to remain in the system for 5 minutes.
10. Connect Bucket 3 to system.
11. Draw sanitizing solution through system until solution is dispensed.
12. Repeat step 11 until all syrup circuits contain sanitizer solution.
13. Allow sanitizer solution to remain in system for 15 minutes.
14. Remove nozzles and diffusers from beverage valves.
15. Scrub nozzles, diffusers and all removable valve parts (except electrical parts) with a plastic brush or a soft cloth and the detergent solution.
16. Soak nozzles, diffusers and removable valve parts (except electrical parts) in sanitizer for 15 minutes.
17. Replace nozzles, diffusers and valve parts.
18. Connect Bucket 1 to system.
19. Draw rinse water through system until no presence of sanitizer is detected.
20. Attach syrup connectors to BIBs.
21. Draw syrup through system until only syrup is dispensed.
22. Discard first 2 drinks.

FIGAL BEVERAGE SYSTEM

1. Prepare the following in three clean Figal tanks:
 - **Rinse tank** - fill with room temperature tap water.
 - **Detergent tank** - mix approved beverage system cleaner with warm water as directed.
 - **Sanitizing tank** - mix a solution of unscented bleach (5% Na CL O) or commercial sanitizer and warm to hot water. Mixture should supply 100 PPM available chlorine (1/4 oz. bleach to 1 gallon water).
2. Disconnect all product and water lines from product tanks and remove carbonator.
3. Locate the Figal syrup tank for the circuit to be sanitized. Remove both quick disconnects from the Figal syrup tank. Rinse quick disconnects in tap water.
4. Connect rinse tank to the syrup line. Draw clean rinse water through the valve until syrup is flushed from the system.
5. Connect detergent tank to the syrup line and draw detergent through the valve for two minutes. Then, allow remaining detergent to stay in the system for five minutes.
6. Connect rinse tank to the syrup line. Draw clean rinse water through the valve until detergent is flushed from the system.
7. Remove valve nozzle and diffuser as shown in Daily Cleaning instructions. Using a plastic brush or a soft cloth and warm water, scrub the nozzle, diffuser, bottom of the dispensing valve and cup lever, if applicable.
8. Place removable valve parts (EXCEPT solenoids) in sanitizing solution for 15 minutes.
9. Replace valve diffuser and nozzle on the beverage valve.
10. Connect sanitizer tank to the syrup line and draw sanitizer through the valve for two minutes. Allow sanitizer to remain in the system for a minimum of 15 minutes.
11. Reconnect syrup and carbonated water lines.
12. Draw syrup through the lines to rinse the system. Discard drinks until at least two cups of satisfactory tasting beverage are dispensed through the valve.

Back-flow Preventer Maintenance

The integral carbonator in this unit is equipped with a back-flow preventer designed to protect the potable water supply from CO₂ contamination.

Important

The back-flow preventer must be checked at least once every year to confirm that it is functioning properly.

1. Shut OFF power to unit.
2. Shut OFF potable water supply to unit. Do not shut OFF CO₂ supply.
3. Remove top cover panel of unit and disconnect inlet fitting from back-flow preventer.

NOTE: The carbonator tank is still pressurized.

4. Observe inlet of backflow preventer #1 check for any discharge. If there is no discharge, #1 check is OK. Proceed to step 5. If there is discharge, proceed to step 6.
5. Disconnect and carefully remove #1 check assembly. Avoid losing any internal parts.
6. Observe inlet of #2 check for any discharge. If there is no discharge, #2 check is OK. Proceed to step 7. If there is discharge, proceed to step 5.
7. Shut OFF CO₂ supply and relieve pressure from carbonator tank.
8. Remove back-flow preventer and install new backflow preventer. Turn ON CO₂ supply and check for leaks.
9. Check water supply strainer upstream of backflow preventer. Clean out and/or replace as required.
10. Reconnect water lines and turn water supply ON.
11. Turn ON power to unit.

Shipping, Storage and Relocation

Caution

Before shipping, storing, or relocating this unit, syrup systems must be sanitized. After sanitizing, all liquids (sanitizing solution and water) must be purged from the unit. A freezing environment causes residual sanitizing solution or water remaining inside the unit to freeze, resulting in damage to internal components.

THIS PAGE INTENTIONALLY LEFT BLANK

Section 5 Before Calling for Service

Checklist

If a problem arises during operation of your post mix soda refrigeration unit, follow the checklist below before calling service. Routine adjustments and maintenance procedures are not covered by the warranty.

Warning

Only trained and certified electrical and plumbing technicians must service this unit. All wiring and plumbing must conform to national and local codes.

Problem	Possible Cause	To Correct
Water only dispensing: No pressure	Regulator(s) out of adjustment	Check/adjust regulator(s).
	Out of CO ₂	Install fresh tank.
	Defective regulator(s)	Check/repair/replace regulator(s).
	CO ₂ line pinched, kinked, or obstructed	Check/repair/replace CO ₂ line.
Syrup and CO ₂ only dispensing: Carbonator	No power	Check power supply. Plug in carbonator or reset breaker.
	Water supply	Make sure water is turned ON.
		Replace water filter.
		Check/clean/replace pump strainer.
		Check/clean/repair water check valve.
Defective carbonator	Check for frozen water line. Internal Carbonator unit only.	
Syrup and plain water only dispensing: No pressure	Defective carbonator	Check/repair/replace carbonator pump, motor, electrode or liquid level control.
	Out of CO ₂	Install fresh tank.
	HP regulator out of adjustment	Adjust HP regulator to the proper setting.
	Defective HP regulator	Check/repair/replace HP regulator.
One valve will not dispense anything: Is there power to the valve?	CO ₂ line pinched, kinked, or obstructed	Check/repair/replace CO ₂ line.
	Broken wire or loose connection	Replace/repair wire or connector.
Beverage dispensed is too sweet: Is the ratio (brix) of the drink correct?	Bad microswitch	Replace microswitch.
	Flow control out of adjustment	Adjust the flow control.
	Insufficient soda flow due to low carbonator pressure	Adjust CO ₂ pressure or change the tank.
	Low CO ₂ pressure due to leaks	Repair CO ₂ leaks.
Beverage is not sweet enough: Is the ratio (brix) of the drink correct?	Obstruction in the water or soda line	Clean out the lines.
	Flow control out of adjustment	Adjust the flow control.
	Soda flow too high	Reset CO ₂ pressure or replace regulator if necessary.
Drinks are foaming: Are system pressures correct?	Obstruction in syrup line	Clean out the syrup line.
	Over carbonation	Check CO ₂ supply. Reset pressure or replace regulator is necessary.
	Dirty lines/valves	Clean sanitize entire system.

THIS PAGE INTENTIONALLY LEFT BLANK

EC DECLARATION OF CONFORMITY

We hereby declare that our products, ice machines and Multiplex refrigeration equipment comply with all the essential requirements of the listed EC - directives.

Manufacturer:

Manitowoc Ice, Inc.
2110 S. 26th Street, P.O. Box 1720
Manitowoc, Wisconsin 54221-1720 USA

European Distributor:

Representative of Manitowoc Ice, Inc.:

Engineering Manager, (Printed name)

Representative of European Distributor:

Signature

Model and Serial No.

Applied EC Directives:

Applied Standards:

EN60335-1 Safety of household and similar electrical appliances
EN60335-2-24 Particular requirements refrigerators, food freezers and ice makers

EN55014 Electrical Motor Operated Appliances (Emissions)
EN55014 Electro Magnetic Compatibility (Immunity)
EN138 -1 to -4 Refrigeration Plants

Low Voltage 73/23/EEC
EMC 89/336/EEC
Pressure Equipment 97/23/EC



8201043
08/25/03



© 2008 Manitowoc

Continuing product improvements
may necessitate change of
specifications without notice.

Part Number 000003912 2/10



Manitowoc Foodservice
2100 Future Drive
Sellersburg, IN 47172, USA
Ph: 812-246-7000 Fax: 812-246-7024
Visit us online at: www.manitowocfsg.com

