



Soda Systems & SuperChill™ Refrigeration Units

Technician's Handbook

This manual is updated as new information and models are released. Visit our website for the latest manual.
www.manitowocfsg.com

America's Quality Choice in Refrigeration
Part Number STH12 9/10



Safety Notices

As you work on Manitowoc equipment, be sure to pay close attention to the safety notices in this handbook. Disregarding the notices may lead to serious injury and/or damage to the equipment.

Throughout this handbook, you will see the following types of safety notices:



Warning

Text in a Warning box alerts you to a potential personal injury situation. Be sure to read the Warning statement before proceeding, and work carefully.



Caution

Text in a Caution box alerts you to a situation in which you could damage the equipment. Be sure to read the Caution statement before proceeding, and work carefully.

Procedural Notices

As you work on Manitowoc equipment, be sure to read the procedural notices in this handbook. These notices supply helpful information which may assist you as you work.

Throughout this handbook, you will see the following types of procedural notices:

Important

Text in an Important box provides you with information that may help you perform a procedure more efficiently. Disregarding this information will not cause damage or injury, but it may slow you down as you work.

NOTE: Text set off as a Note provides you with simple, but useful, extra information about the procedure you are performing.

Read These Before Proceeding:

Caution

Proper installation, care and maintenance are essential for maximum performance and trouble-free operation of your Manitowoc equipment. If you encounter problems not covered by this handbook, do not proceed, contact Manitowoc Foodservice Group. We will be happy to provide assistance.

Important

Routine adjustments and maintenance procedures outlined in this handbook are not covered by the warranty.

Warning

PERSONAL INJURY POTENTIAL

Do not operate equipment that has been misused, abused, neglected, damaged, or altered/modified from that of original manufactured specifications.

We reserve the right to make product improvements at any time. Specifications and design are subject to change without notice.

Table of Contents

General Information

Model Numbers	9
How to Read a Model Number	10
Accessories	10
Special Applications	11
Model/Serial Number Location	11
Warranty Information	11

Installation

Pre-installation Checklist	13
Top Mounted Ice Maker Installations	15
S250-M Dimensions	16
MII-250 Dimensions	18
MII-302 Dimensions	20
MII-250 Installation Kit	22
MII-302 Installation Kit	23
Refrigeration Units	25
Safe Installation Dos and Don'ts	28
Location Requirements	30
Electrical	34
Plumbing/Water Supply	38
Preparing Ice Bank – Non-ERC	39
Preparing Ice Bank with ERC	41

Component Identification

Typical System	43
Connections	44

Maintenance

Maintenance Schedule	49
Cleaning and Sanitizing the Dispensing Valves and Product Lines	54
Sanitizing	58
Shipping, Storage and Relocation	62

Operation

How the Multiplex Works	63
Differences Between the TS & SS Units	64
Equipment Setup Procedure (Non-ERC)	71

Start-up (Non-ERC)	72
Sequence of Operation (Non-ERC)	74
Start-up (with ERC)	76
Sequence of Operation (with ERC)	78
Equipment Setup Procedure (with ERC)	82
Equipment Close Procedure — All Units	84

Troubleshooting

Electronic Refrigeration Control (ERC) Model

Error Codes	87
Checklist	98
Problem Cross-reference Guide	100
CO ₂ Gas System	101
Carbonated Water System	104
Circulating System	111
Compressed Air System	112
Dispensing Valve and Tower	114
Electrical System	119
Refrigeration System	120
Syrup System	123
Water Booster System	125
Water Filter System	127
When the Brix is OFF	128

Component Check Procedures

Test Procedures: MPC 64A Timer/Selection Pad	131
Dual Transformers	133
New MPC84A Portion Control Board ...	134
MOVs Field Testing	140
Test Procedures: MPC84C Timer/Selection Board	141
Back-flow Preventer Maintenance	144
Head Pressure Control Valve	145
Charging Multiplex Remote Refrigeration Unit	147
Compressor & Remote Condenser	148
Agitator Condenser	149
Carbonation System A or B	150
Circulation System A or B	151
ERC Control Board, Keypad & Display .	152
Programming / Auto Set	153

ERC Component (Output) Connector Layout	154
ERC Sensor (Input) Connector Layout	. 154
Component Specifications	
Refrigeration Unit Specifications 155
S-250M Specifications 156
MII-302 Specifications 156
Charts	
Refrigerant Charge 157
Operating Pressures 161
McDonald's Models History 163
Sustained Draw Curve Charts 164
Diagrams	
Wiring Diagrams 167
Soda Wiring Diagrams 185
Super-Chil Wiring Diagrams 200
Circuit Schematics 212
Ice/Beverage Units Diagrams 231

This Page Intentionally Left Blank

General Information

Model Numbers

This manual covers the following models:

(A) Air Cooled	(W) Water Cooled	(R) Remote Cooled
2803A04	2803W04	2803R04
2803AX04	2803WX04	2803RX04
2803A04	2803W04	2803R04
11MA04	11MW04	11MR04
11MAX04	11MAW04	11MRX04
11MA04	11MW04	11MR04
42MA04	42MW04	42MR04
42MAX04T	42MWX04T	42MRX04T
44MA04	44MW04	44MR04
44MAX04T	44MWX04T	44MRX04T
44EAX04T	44EWX04T	44ERX04T
50MA04	50MW04	50MR04
50MAX04	50MWX04	50MRX04
50MA04Q/T	50MW04Q/T	50MR04Q/T
SC180A	SC180W	SC180R
SC180AX	SC180WX	SC180RX
SC340A	SC340W	SC340R
SC340AX	SC340WX	SC340RX
SC1000A	SC1000W	SC1000R
SC1000AX	SC1000WX	SC1000RX
SC2000A	SC2000W	SC2000R
SC2000AX	SC2000WX	SC2000RX

Ice/Beverage Dispensers	
MII-302	S-250M

How to Read a Model Number

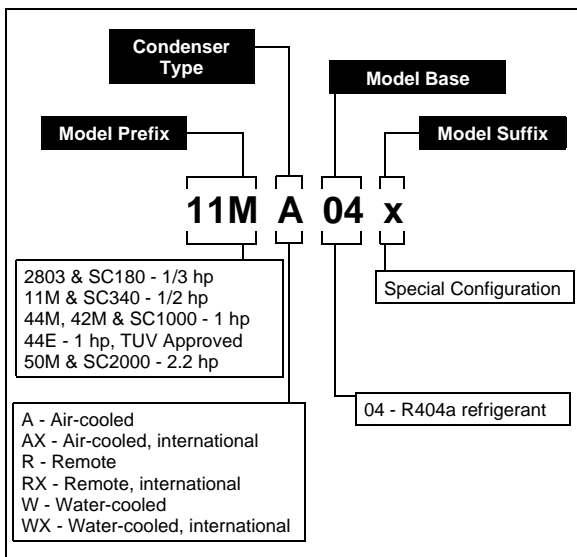

ICE/BEVERAGE MODEL NUMBERS

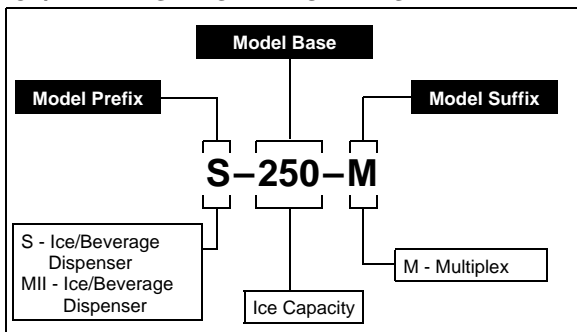

Accessories

Depending on store type and location, various optional equipment (such as CO₂ Panel, water filter kit, water booster kit, etc.) may be added to this system. Install and connect any optional equipment in the desired location according to the installation instructions provided with these kits/equipment.

Special Applications

ATTENTION: MARINE INSTALLATIONS



Warning

This unit is for use on vessels over 66 ft (20 m) in length. This unit must not be installed in the engine space of a gasoline-powered ship.

NOTE: This unit must be secured to the vessel during installation. Models with part numbers beginning with the letters TS are NOT marine listed.

OUTDOOR APPLICATIONS

TS Multiplex Beverage Recirculating units are approved and listed by Underwriters Laboratories (UL). However they are not UL approved for weather exposure applications. These units must be installed in areas where adequate protection from the elements is provided, all other models are ETL listed.



Warning

Personal Injury Potential

Do not operate equipment that has been misused, abused, neglected, damaged, or altered/modified from that of original manufactured specifications.

Model/Serial Number Location

These numbers are required when requesting information from your local Manitowoc Distributor, service representative, or Manitowoc Foodservice. The model and serial number are listed on the OWNER WARRANTY REGISTRATION CARD. They are also listed on the MODEL/SERIAL NUMBER DECAL affixed to the unit.

Warranty Information

Consult your local distributor for terms and conditions of your warranty. Your warranty specifically excludes all beverage valve brixing, general adjustments, cleaning, accessories and related servicing.

Your warranty card must be returned to activate the warranty on this equipment. If a warranty card is not returned, the warranty period can begin when the equipment leaves the factory.

No equipment may be returned without a written Return Materials Authorization (RMA). Equipment returned without an RMA will be refused at the dock and returned to the sender at the sender's expense.

Please contact your local distributor for return procedures.

Installation

Pre-installation Checklist

When installing any system, first make sure the major components are available. Generally the major components necessary for an installation are:

B-I-B System also:

- B-I-B connectors
- B-I-B regulator set
- B-I-B rack
- B-I-B syrup boxes

Bulk Syrup System also:

- Syrup connectors for Bulk tank
- Gas connectors for Bulk tank
- Bulk syrup tanks

Post Mix System:

- CO₂ regulator set
- Beverage dispenser
- Beverage tubing
- CO₂ tank
- Carbonator
- Stepless (Oetiker) clamps
- Chain for CO₂ tank

Double Check:

- Do you have enough space to install the dispenser or a dispenser and top mounted cuber?
- Does top mounted cuber (if utilized) have a minimum of 6 inches (15.3 cm) clearance on all sides?
- Is the countertop level?
- Can the countertop support the weight of the dispenser, or the dispenser/cuber combination plus the weight of the stored ice?

Also consider the location of the following items before installation:

Water line

Drain

Power outlet

Heating and air conditioning ducts

Top Mounted Ice Maker Installations

Location — Avoid placing the dispenser and/or ice machine near heat sources such as radiators, ovens, refrigeration equipment and direct sunlight.

Clearances — Six inch (15.2 cm) clearance on all sides of the icemaker is needed.

Front of icemaker to be flush with front of dispenser — The front of the icemaker must be flush with the front of the dispenser. When the icemaker is flush with the front of the dispenser, some icemakers may overhang at the back of the dispenser.

Drains — A separate drain line is required for the ice machine, in addition to a drain line for the ice/beverage dispenser.

Dispensers require an adapter kit to install some top-mounted icemakers. Contact your local distributor for the correct adapter kit.

S250-M Dimensions

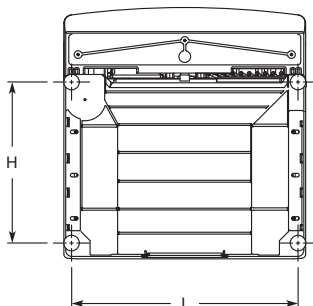
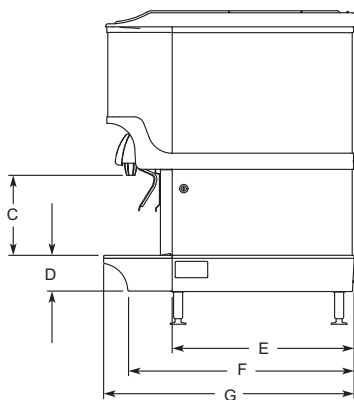
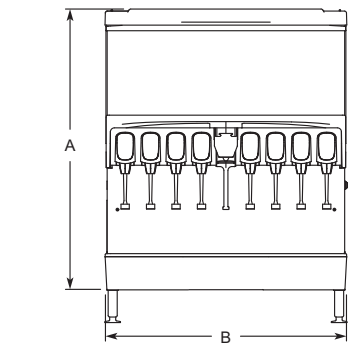

A	39.81" (101.1 cm)
B	30.00" (76.2 cm)
C	9.94" (25.2 cm)
D	4.44" (11.3 cm)
E	22.63" (57.5 cm)
F	28.00" (71.1 cm)
G	31.13" (79.1 cm)
H	20.00" (50.8 cm)
I	27.44" (69.7 cm)

S250-M FOOTPRINT

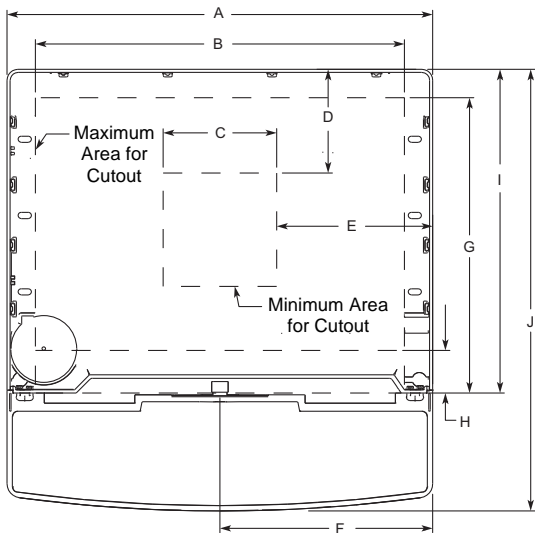

A	B	C	D	E
30.00" (76.2 cm)	26.00" (66.0 cm)	8.00" (20.3 cm)	7.30" (18.5 cm)	11.00" (27.9 cm)
F	G	H	I	J
15.00" (38.1 cm)	20.81" (52.8 cm)	3.00" (7.6 cm)	22.81" (57.9 cm)	31.13" (79.1 cm)

MII-250 Dimensions

Front View

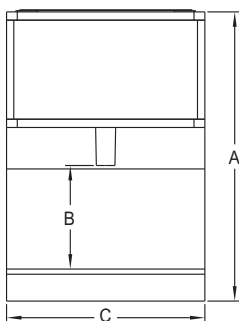

Back View

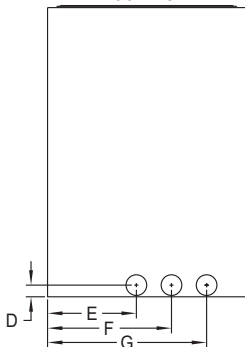

Bottom View

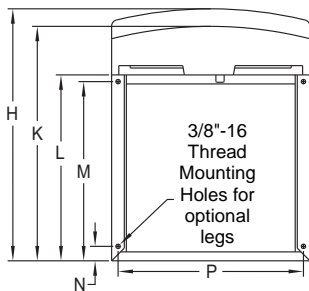

A	39.00" (99.1 cm)
B	12.50" (31.8 cm)
C	30.00" (76.2 cm)
D	1.50" (3.8 cm)
E	9.94" (25.2 cm)
F	13.50" (34.3 cm)
G	20.00" (50.8 cm)
H	30.50" (77.5 cm)
K	28.38" (72.1 cm)
L	22.50" (57.2 cm)
M	21.69" (55.1 cm)
N	1.75" (4.4 cm)
P	28.44" (72.2 cm)

MII-250 FOOTPRINT

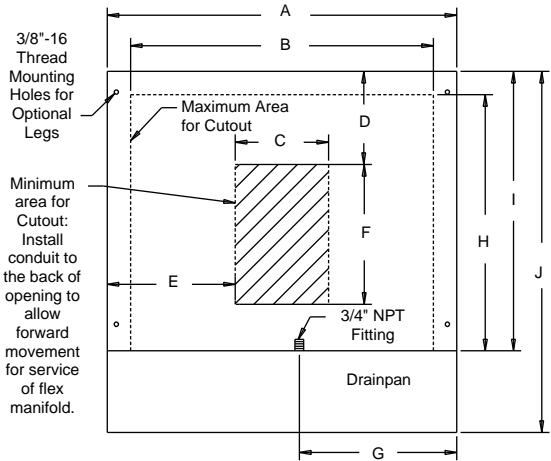

A	B	C	D	E
30.00" (76.2 cm)	26.00" (66.0 cm)	8.00" (20.3 cm)	8.00" (20.3 cm)	11.00" (27.9 cm)
F	G	H	I	J
12.00" (30.5 cm)	13.50" (34.3)	22.00" (55.9cm)	24.00" (61.0 cm)	31.00" (78.7 cm)

MII-302 Dimensions

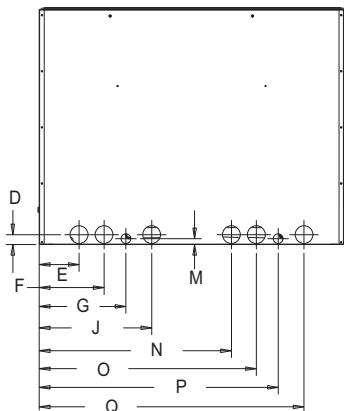
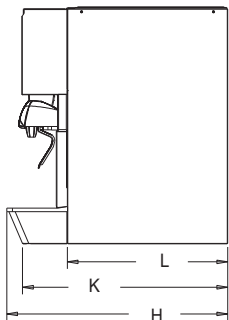
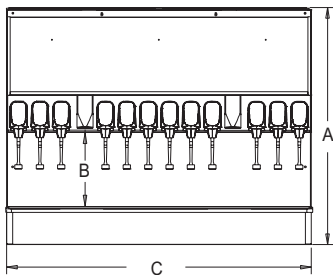

A	33.25" (84.5 cm)
B	12.50" (31.8 cm)
C	42.75" (108.6 cm)
D	1.38" (3.5 cm)
E	5.59" (14.2 cm)
F	9.10" (23.1 cm)
G	12.16" (30.9 cm)
H	31.00" (78.7)
J	15.78" (40.1 cm)
K	28.78" (73.1 cm)
L	22.50" (57.2 cm)
M	0.82" (2.1 cm)
N	26.97" (68.5 cm)
O	30.47" (77.4 cm)
P	33.75" (85.7 cm)
Q	37.16" (94.4 cm)

MII-302 FOOTPRINT

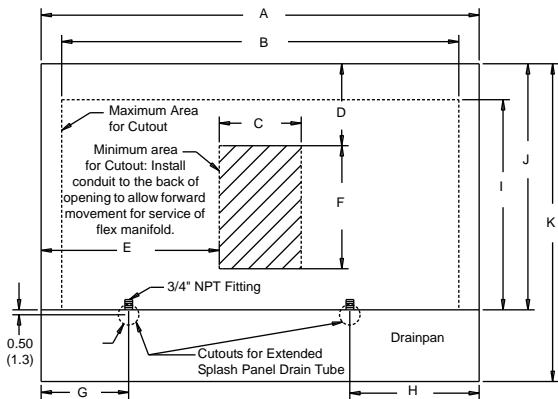

A	B	C	D
42.75" (108.6 cm)	38.75" (98.4 cm)	8.00" (20.3 cm)	8.00" (20.3 cm)
E	F	G	H
17.38" (44.1 cm)	12.00" (30.5 cm)	8.54" (21.7 cm)	12.63" (32.1 cm)
I	J	K	
20.50" (52.1 cm)	24.00" (61.0 cm)	31.00" (78.7 cm)	

MII-250 Installation Kit

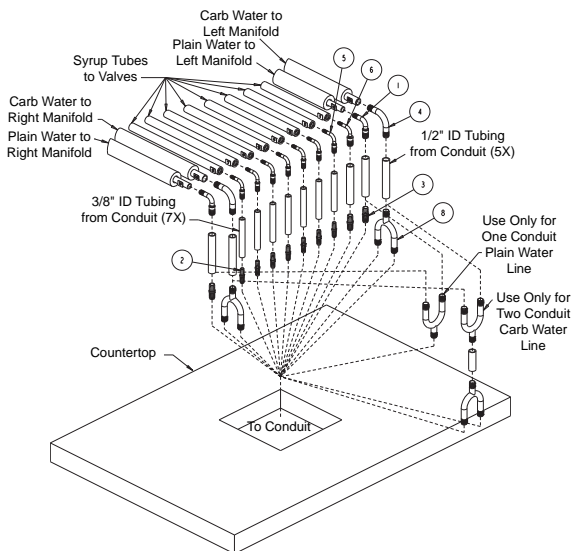

No.	Part Number	Description	Qty.
1	00854998	Ell 1/2 x 3/8 Barb SS	2
2	00861304	Splicer 3/8 x 3/8 Barb	7
3	00861306	Splicer 1/2 x 1/2 Barb	3
4	5018595	Splicer Elbow SS 1/2 x 1/2	2
5	5030996	Elbow 1/4 x 3/8 Barb SS	7
6	5030997	Elbow 1/4 x 1/2 Barb SS	1
7	5030998	U-bend 1/2 x 1/2 WI - 1/2 Stem	3

MII-302 Installation Kit

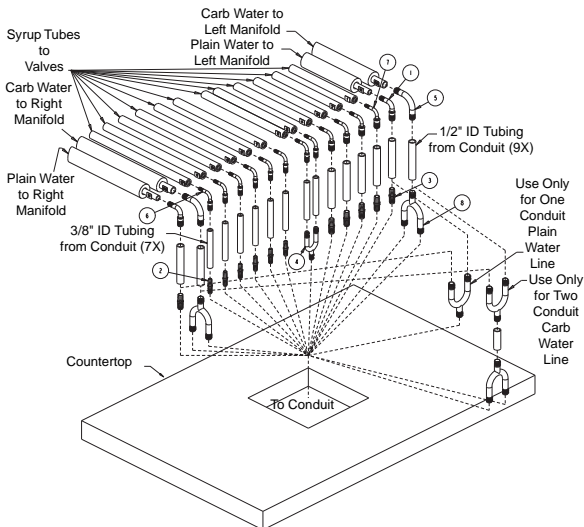

No.	Part Number	Description	Qty.
1	00854998	El 1/2 x 3/8 Barb SS	2
2	00861304	Splicer 3/8 x 3/8 Barb	6
3	00861306	Splicer 1/2 x 1/2 Barb	6
4	5011751	Fitting 3/8" Y Barb	1
5	5018595	Splicer Elbow SS 1/2 x 1/2	2
6	5030996	Elbow 1/4 x 3/8 Barb SS	8
7	5030997	Elbow 1/4 x 1/2 Barb SS	4
8	5030998	U-bend 1/2 x 1/2 WI - 1/2 Stem	3

WATER AND SYRUP LINES

This kit facilitates connecting the unit to a 12-16 line conduit, with one or two carbonated water recirculating systems, and one or two plain water supply lines, and maximum 8 syrup product lines.

The unit is shipped with connecting lines terminating under the unit. It will be necessary to make a 90° turn

down through the counter top, to connect to the conduit. It will also be necessary to fully insulate this new added section before passing through the counter top, or before hooking to main conduit.

CARB WATER LINES

- Unit has two carb water lines, one for each flex manifold.
- Use 2 @ 1/2" x 1/2" elbow and 6-12" of 1/2" conduit tubing to make connection bend from unit down through hole in counter top, to mate with conduit.
- Conduit with only two circulating carb water lines.
- Use two @ 1/2" barb U-bend adapters (invert one) to connect the two carb circulating lines from conduit to the two carb water lines from the unit. Use short 1/2" conduit line to connect the two U-bends as shown (item #8).
- Conduit with four, two sets of recirculating carb water lines.
- Use two @ 1/2" barb U-bend adapters, to connect each set of circulating conduit lines to each carb water line from unit as shown (8).

PLAIN WATER LINES

- Unit has two plain water lines, one for each flex manifold.
- Use two @ 3/8" x 1/2" elbows and 6-12" of 1/2" conduit tubing to make connection bend from unit down through hole in counter top, to mate with conduit.
- Conduit with only one plain water line.
- Use one @ 1/2" U-bend adapter, to connect the two plain water lines to one plain water line from conduit (item #3).
- Conduit has two plain water lines.
- Use two @ 1/2" straight adapters to connect each plain water line from unit to each plain water line from conduit as shown (3).

SYRUP LINES

- Unit has eight syrup lines.
- Use seven @ 1/4 x 3/8" and one @ 1/4 x 1/2" elbows and proper size conduit tubing to make connection bend from unit down through hole in counter top, to mate with conduit.
- FULLY INSULATE (no air gaps) and finish with tape wrap, all these connections from unit, through 90° bend connection and down close to straight conduit connection. Locate unit properly on counter, and secure to counter. Finish connections to conduit with 3/8" x 3/8" and 1/2" x 1/2" straight barb connectors, and U-bend adapters, as needed.
- FULLY INSULATE and finish with tape wrap all these connections to the conduit.

Refrigeration Units

- Refrigeration units require stand or 6" (15.2 cm) legs. Refrigeration unit cannot be placed directly on floor.
- Conduit can be run through floor or ceiling chase.
- Syrup supply can be located on stand or adjacent to refrigeration unit.

CLEARANCES

Control Side (Right)	18" (45.7 cm)
Tower Connection Side (Left)	12" (30.5 cm)
Back Side	6" (15.2 cm)
Ceiling	18" (45.7 cm)

REMOTE CONDENSER LINESET REQUIREMENTS

Important

If you have a MAC Multi-Pass condenser please add three (3) pounds additional charge.

Important

If you exceed the 100ft line set length add .72oz/ft of line set run (one way) for every foot over 100ft, to the UNIT charge

1. Both the discharge and liquid remote condensing lines must be kept to a minimum distance for maximum performance. All Multiplex systems are capacity rated to 100 ft (30.5 m) tubing distance between the compressor and condenser. If you have another brand condenser, please add additional charge for the condenser (example: up to three (3) pounds for a MAC condenser).
2. Any vertical rise 25 ft (7.62 m) or greater must have a manufactured or installed trap (bend), in the discharge refrigeration line from the compressor to the remote condenser. A trap is necessary for every additional 25 ft (7.62 m) vertical rise. When excessive vertical rise exists, this trap allows oil to reach the condenser and return to the compressor.

3. The easiest method to create a trap is to bend the tubing (smoothly, no kinks) into the trap form.

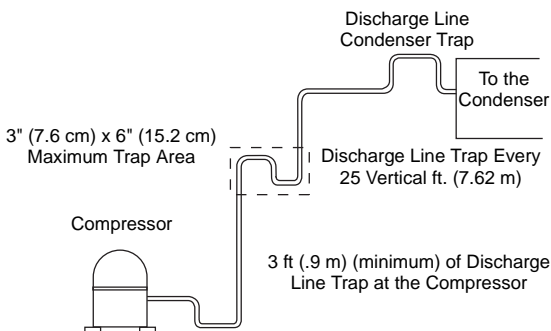

4. The trap(s) must be of minimum height of 3" (7.6 cm) and a width of 6" (15.2 cm) to minimize oil accumulation. The traps can also be bent out of the refrigeration tubing. Carefully bend the tubing down 12", and then sweep the tubing back up.
5. It is critical that the remote condensing line size specifications for the specific model be maintained. The specifications are 1/2" discharge and 3/8" liquid lines.

Safe Installation Dos and Don'ts

Warning

Read the following warnings before beginning an installation. Failure to do so may result in possible death or serious injury.

- Adhere to all National and Local Plumbing and Electrical Safety Codes.
- Turn OFF incoming electrical service switches when servicing, installing, or repairing equipment.
- **DO NOT** throw or drop a CO₂ cylinder. Secure the cylinder(s) in an upright position with a chain.
- **DO NOT** store CO₂ cylinders in temperature above 125°F (51.7°C) near furnaces, radiator or sources of heat.

Warning

DO NOT connect the CO₂ cylinder(s) directly to the product container. Doing so will result in an explosion causing possible death or injury. It is best to connect the CO₂ cylinder(s) to a regulator(s).

Warning

Carbon Dioxide (CO₂) displaces oxygen. Exposure to a high concentration of CO₂ gas causes tremors, which are followed rapidly by loss of consciousness and suffocation. If a CO₂ gas leak is suspected, particularly in a small area, immediately ventilate the area before repairing the leak. CO₂ lines and pumps must not be installed in an enclosed space. An enclosed space can be a cooler or small room or closet. This may include convenience stores with glass door self serve coolers. If you suspect CO₂ may build up in an area, venting of the BIB pumps and/or CO₂ monitors must be utilized.

- **DO** check that all flare fittings are tight. This check must be performed with a wrench to ensure a quality seal.
- **DO** inspect pressure on regulators before starting up equipment.
- **DO** protect eyes when working around refrigerants.
- **DO** use caution when handling metal surface edges of all equipment.
- **DO** handle CO₂ cylinders and gauges with care. Secure cylinders properly against abrasion.
- **DO** store CO₂ cylinder(s) in well ventilated areas.
- **DO NOT** exhaust CO₂ gas (example: syrup pump) into an enclosed area, including all types of walk-in coolers, cellars, and closets.
- **DO NOT** release CO₂ gas from old cylinder.
- **DO NOT** touch refrigeration lines inside units; some may exceed temperatures of 200°F (93.3°C).

NOTE: All utility connections and fixtures must be sized, installed, and maintained in accordance with Federal, State, and Local codes.

Location Requirements

SODA REFRIGERATION UNIT “QUICK-PICK” SELECTION CHART

Number of Dispensing Stations				
Business Level*	1	2	3	4
Up to 6 gal / 3 L of syrup/day or 280 drinks/day (2,000 gal/yr)	Model 2803 40 ft / 12 m Maximum Conduit Length	Model 11M 100 ft / 30 m Maximum Conduit Length	Model 44M 250 ft / 80 m Maximum Conduit Length	Model 44M 250 ft / 80 m Maximum Conduit Length
Up to 12 gal / 45 L of syrup/day or 560 drinks/day (4,000 gal/year)	Model 11M 100 ft / 30 m Maximum Conduit Length	Model 11M 100 ft / 30 m Maximum Conduit Length	Model 44M 250 ft / 80 m Maximum Conduit Length	Model 44M 250 ft / 80 m Maximum Conduit Length
Up to 21 gal / 79 L of syrup/day or 980 drinks/day (7,500 gal/yr)	Model 44M 250 ft / 80 m Maximum Conduit Length	Model 44M 250 ft / 80 m Maximum Conduit Length	Model 44M 250 ft / 80 m Maximum Conduit Length	Model 44M 250 ft / 80 m Maximum Conduit Length
Up to 32 gal / 121 L of syrup/day or 1400 drinks/day (11,500 gal/yr)	Model 44M 250 ft / 80 m Maximum Conduit Length	Model 44M 250 ft / 80 m Maximum Conduit Length	Model 50M 350 ft / 107 m Maximum Conduit Length	Model 50M 350 ft / 107 m Maximum Conduit Length
Up to 42 gal / 159 L of syrup/day or 2000 drinks/day (15,000 gal/yr)	Model 50M 350 ft / 107 m Maximum Conduit Length	Model 50M 350 ft / 107 m Maximum Conduit Length	Model 50M 350 ft / 107 m Maximum Conduit Length	Model 50M 350 ft / 107 m Maximum Conduit Length
* Care must be taken when selecting the proper refrigeration unit. Above selections are for 75°F (24°C) conditions, 16 ounce (470 ml) drinks, and average business cycles. Other factors such as lunch or dinner peak periods, large drinks, or high ambient conditions may require the next larger size unit. Contact your Manitowoc Company Authorized Distributor or Manitowoc Beverage Systems (MBS) for more information.				

Select a location for the refrigeration unit that meets the requirements of the building plans, local codes, and personnel. The unit must be positioned for free airflow as well as for future service. The following minimum requirements must be met:

- 100 GPH (379 LTR/hr) potable water supply Models 2803/11/38; 200 GPH (757 LTR/hr) potable water supply Models 44/50
- Beverage quality CO₂ gas (bulk or bottled supply) with a minimum 3/8" (.96 cm) line
- One Bag-In-Box (BIB) container of each post mix syrup flavor.

NOTE: Refer to nameplate on side of refrigeration unit for voltage and amperage specifications. Make all electrical connections at the junction box located at the top rear of unit. Optional equipment may require additional power supplies.

NOTE: Potable water connections to the equipment must comply with local plumbing code requirements, particularly the back-flow prevention requirements.

PLUMBING REQUIREMENTS – GENERAL

Incoming water supply must be provided before installation of the refrigeration unit and must comply with local plumbing requirements.

1. A minimum 1" (2.54 cm) water supply line with a manual shut-off valve must be plumbed at least 6 ft (183 cm) from the unit. The incoming water supply pressure must not exceed 70 psi static (4.8 bar) and be no less than 40 psi (2.8 bar) dynamic. If supply water pressure is greater than 70 psi (5 bar), a water regulator will be required.
2. Locate the drain hose, bracket, and two screws provided in the installation kit. Attach the drain hose to the water bath overflow tube located on the bottom of the refrigeration unit.

3. Connect the water manifold supply line, located on the bulkhead panel in the motor compartment to the main water supply. The main water supply shut-off valve must remain in the OFF position. If a water filter is to be installed, connect the line to the outlet fitting of the filter. Plumb according to applicable plumbing codes.

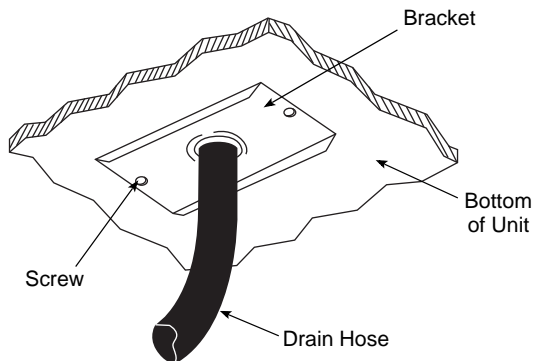

Drain Hose Connection

4. When a water cooled condenser is installed, a copper supply line (not supplied with unit) must be plumbed to the 3/8" (.965 cm) male flare fitting installed in the water shut-off assembly. The shut-off must be placed in the OFF position. A copper drain line (not supplied) is to be connected to the outlet fitting of the water cooled condenser and routed to the floor drain.

WATER SUPPLY

1. Use the built in fill valve that is already plumbed into the unit.
2. An appropriate floor drain is required within 6 ft (2 m) of the unit.
3. Potable water connections to the equipment must comply with the basic plumbing code of the Building Officials and Code Administrators International, Inc. (BOCA) and the Food Service Sanitation Manual of the Food and Drug Administration. Verify local plumbing code requirements.

Electrical

GENERAL



Warning

All wiring must conform to local, state and national codes.

MINIMUM CIRCUIT AMPACITY

The minimum circuit ampacity is used to help select the wire size of the electrical supply. (Minimum circuit ampacity is not the unit's running amp load.) The wire size (or gauge) is also dependent upon location, materials used, length of run, etc., so it must be determined by a qualified electrician.

ELECTRICAL REQUIREMENTS

Refer to unit's Model/Serial Plate for voltage/amperage specifications.

SPECIFICATIONS

Model	Volt/Cycle/Phase	Minimum Circuit Amps	Breaker	Compressor
2803 & SC180	120/60/1 230/50/1	20.3 9.0	25A 16A	1/3 hp .46 kW
11M & SC340	120/60/1 230/50/1	21.5 10.7	30A 16A	1/2 hp .97 kW
44M, 42M & SC1000	208-230/60/1 230/50/1	20.6 20.6	30A 25A	1 hp 1.9 kW
50M	120* /208-230/60/3 230/400/50/3	25.2 11.6	30A 20A	2.2 hp 2.0 kW
SC2000	208-230/60/3 230/400/50/3	25.2 11.6	20A 15A	2.2 hp 2.0 kW

* Only the model 50M with SS part numbers have 120V components, the TS does not.

GROUNDING INSTRUCTIONS

Warning

The unit must be grounded in accordance with national and local electrical codes.

This appliance must be grounded. In the event of malfunction or breakdown, grounding provides a path of least resistance for electric current to reduce the risk of electric shock.

NOTE: The refrigeration units are not equipped with a cord.

Warning

Improper connection of the equipment-grounding conductor can result in a risk of electric shock. The conductor with insulation having an outer surface that is green with or without yellow stripes is the equipment grounding conductor. If repair or replacement of the cord or plug is necessary, do not connect the equipment-grounding conductor to a live terminal. Check with a qualified electrician or serviceman if the grounding instructions are not completely understood, or if in doubt as to whether the appliance is properly grounded. Do not modify the plug provided with the appliance — if it will not fit the outlet, have a proper outlet installed by a qualified electrician.

Warning

When using electric appliances, basic precautions must always be followed, including the following:

- a. Read all the instructions before using the appliance.
- b. To reduce the risk of injury, close supervision is necessary when an appliance is used near children.
- c. Do not contact moving parts.
- d. Only use attachments recommended or sold by the manufacturer.
- e. Do not use outdoors.
- f. For a cord-connected appliance, the following shall be included:
 - Do not unplug by pulling on cord. To unplug, grasp the plug, not the cord.
 - Unplug from outlet when not in use and before servicing or cleaning.
 - Do not operate any appliance with a damaged cord or plug, or after the appliance malfunctions or is dropped or damaged in any manner. Contact the nearest authorized service facility for examination, repair, or electrical or mechanical adjustment.
- g. For a permanently connected appliance — Turn the power switch to the off position when the appliance is not in use and before servicing or cleaning.
- h. For an appliance with a replaceable lamp — Always unplug before replacing the lamp. Replace the bulb with the same type.
- i. For a grounded appliance — Connect to a properly grounded outlet only. See Grounding Instructions.

Plumbing/Water Supply

PLUMBING POTABLE WATER

Model	Required Water Pressure	Drain Connections	Water Supply
2803 & SC180	40 – 70 psig (2.8 – 4.9 bar)	3/4" ID within 6 ft (2 m)	3/8" ID EVA Line
11M & SC340	40 – 70 psig (2.8 – 4.9 bar)	3/4" ID within 6 ft (2 m)	3/8" ID EVA Line
44M, 42M & SC1000	40 – 70 psig (2.8 – 4.9 bar)	3/4" ID within 6 ft (2 m)	1/2" ID EVA Line
50M	40 – 70 psig (2.8 – 4.9 bar)	3/4" ID within 6 ft (2 m)	1/2" ID EVA Line
SC2000	40 – 70 psig (2.8 – 4.9 bar)	3/4" ID within 6 ft (2 m)	1/2" ID EVA Line

A 1" (2.54 cm) ID copper inlet water line equipped with a 3/4" (1.905 cm) FPT adapter with shut-off must be supplied by plumber at rear of equipment. Appropriate floor drains must be provided within 6 ft (183 cm) of each unit installed.

NOTE: The carbonator in this unit is provided with a dual check valve type back-flow preventer, which conforms to ASSE 1032. The Model 50M & 44M vented backflow preventer conforms to ASSE 1022.

Potable water connections to the equipment must comply with the basic plumbing code of the Building Officials and Code Administrators International, Inc. (BOCA) and the Food Service Sanitation Manual of the Food and Drug Administration. Verify local plumbing code requirements.

Preparing Ice Bank – Non-ERC

BUILDING AN ICE BANK

1. At this time, fill the unit water bath tank to the top, or within 1/2" (1.3 cm) of the top minimum, of the overflow tube. Use a garden hose or another water supply to do this.

NOTE: A manual fill valve is incorporated into the water circuit to the carbonator tank. This valve can be used to manually add water lost for any reason. Do not leave this valve ON constantly, only use it for filling and topping off. The water bath must be drained, flushed, and refilled every six months.

2. Turn ON the switch labeled "Refrigeration". Allow unit to run for about 15 minutes before proceeding to step 3.
3. Turn ON the switch labeled "Agitator".

NOTE: Turn this switch OFF to perform any operations in the water bath area.

With water bath water temperature of 65°F (18°C), ice will begin to form on the evaporator coils in approximately 2 hours. The unit will build a full ice bank in approximately 4 to 6 hours (depending on ambient water temperature).

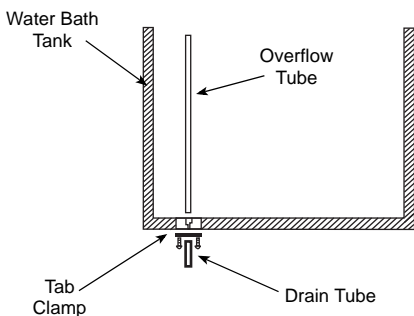

4. Before turning on the carbonator or circulator switch, verify that the pump box assembly has been mounted and connected to the unit and the appropriate syrup and water has been supplied.

5. Turn on the main water supply to the booster assembly. Verify the booster is plugged in and that the accumulator tank valve is open. (If the system has an optional “Out-of-Syrup” device, verify that it is unplugged.)
 6. Verify the pump is running. Place the valve on the right side of the pump box in the purge position until all air bubbles have passed through the line. Turn the valve back to “dispense”. Plug the Out-of-Syrup device power cord into an appropriate wall outlet at this time (if supplied).
- NOTE: Verify that the pump box holding tank is full before proceeding.
7. Turn on the circulator and carbonator switches. The carbonator must run for approximately 1 to 3 minutes and shut off. The circulator must run continuously. Verify that water is returning to the water bath through the return bulk head fitting.

Important

Wait until a thin layer of ice has begun to form on the evaporator before proceeding any further.

8. Go to the tower(s) and brix the valves. Using a syrup separator and volume cup, adjust the flow rate of the carbonated water to two fluid ounces per second. Then, using the separator and a brix cup, adjust the syrup flow rate for a ratio of carbonated water to syrup.

Preparing Ice Bank with ERC

BUILDING AN ICE BANK

1. At this time, fill the unit water bath tank to the top, or within 1/2" (1.3 cm) of the top minimum, of the overflow tube. Use a garden hose or another water supply to do this.

NOTE: A manual fill valve is incorporated into the water circuit to the carbonator tank. This valve can be used to manually add water lost for any reason. Do not leave this valve ON constantly, only use it for filling and topping off. The water bath must be drained, flushed, and refilled every six months.

2. Main power to unit must be on. Power delay of 30 seconds occurs when power applied. "Pd30"
3. Press COMP/AGIT switch on keypad display.
4. Agitator will come on immediately and compressor delay will start. "Cd99" will count from 180 to 0.

NOTE: Turn this switch OFF to perform any operations in the water bath area.

With water bath water temperature of 65°F (18°C), ice will begin to form on the evaporator coils in approximately 2 hours. The unit will build a full ice bank in approximately 4 to 6 hours (depending on ambient water temperature).

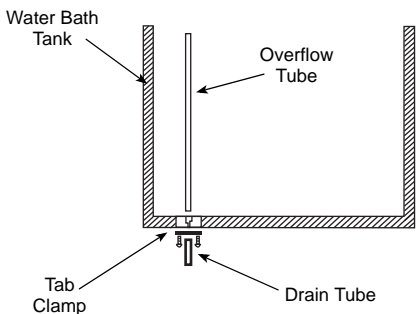

5. Turn on the main water supply to the booster assembly. Verify the booster is plugged in and that the accumulator tank valve is open. (If the system has an optional “Out-of-Syrup” device, verify that it is unplugged.)
6. Verify the pump is running. Place the valve on the right side of the pump box in the purge position until all air bubbles have passed through the line. Turn the valve back to “dispense”. Plug the Out-of-Syrup device power cord into an appropriate wall outlet at this time (if supplied).

NOTE: Verify that the pump box holding tank is full before proceeding.

7. Turn on the circulator and carbonator. The carbonator must run for approximately 1 to 3 minutes and shut off. The circulator must run continuously. Verify that water is returning to the water bath through the return bulk head fitting.

Important

Wait until a thin layer of ice has begun to form on the evaporator before proceeding any further.

8. Go to the tower(s) and brix the valves. Using a syrup separator and volume cup, adjust the flow rate of the carbonated water to two fluid ounces per second. Then, using the separator and a brix cup, adjust the syrup flow rate for a ratio of carbonated water to syrup to 5 to 1.

Component Identification

Typical System

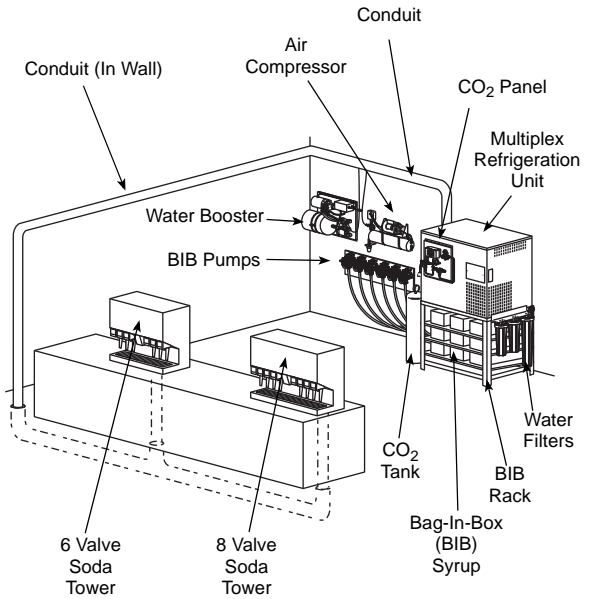

Connections

MODEL 2803 CONNECTIONS

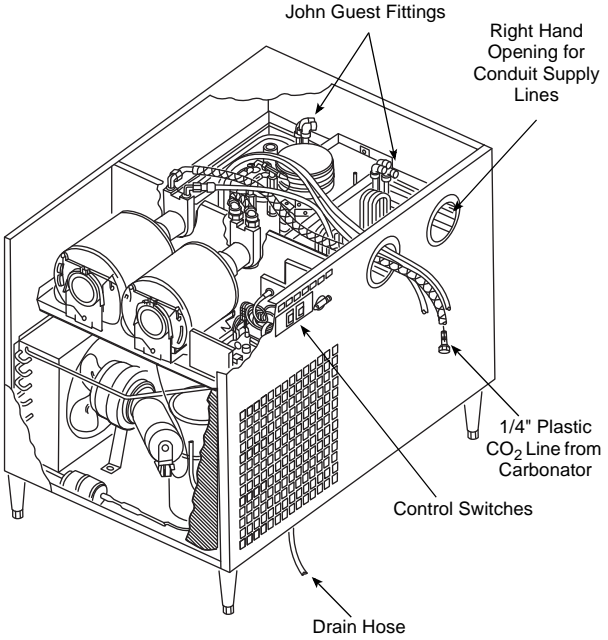

MODEL 11M CONNECTIONS

Opening for
Conduit Supply
Lines

John Guest Fittings

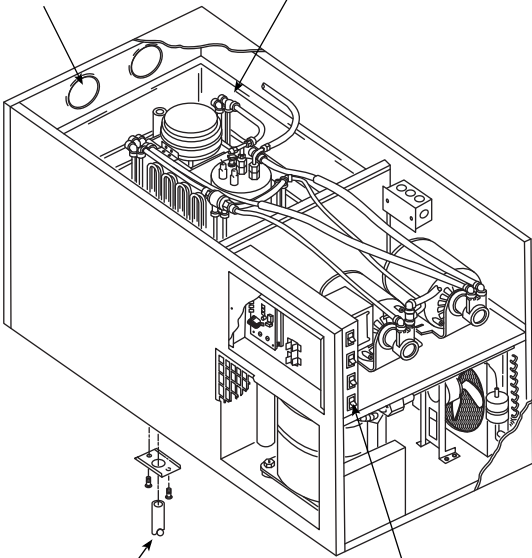

Drain Hose

Control Switches

MODEL 42, 44, & 50M CONNECTIONS

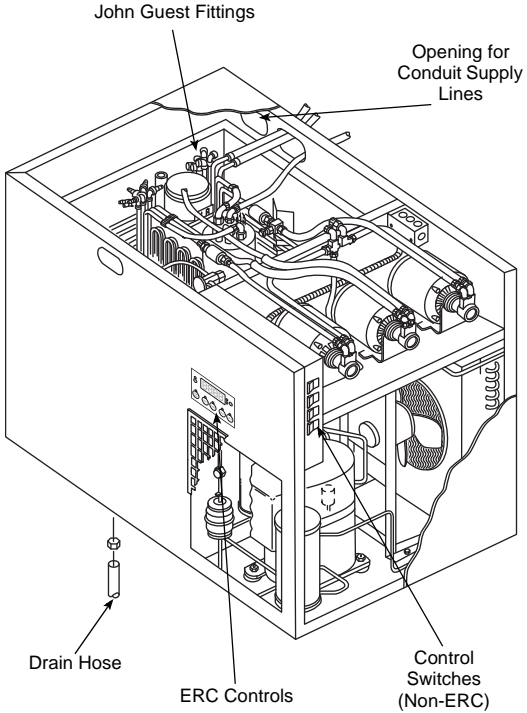

ERC CONTROL BOARD OUTPUT CONNENCTIONS

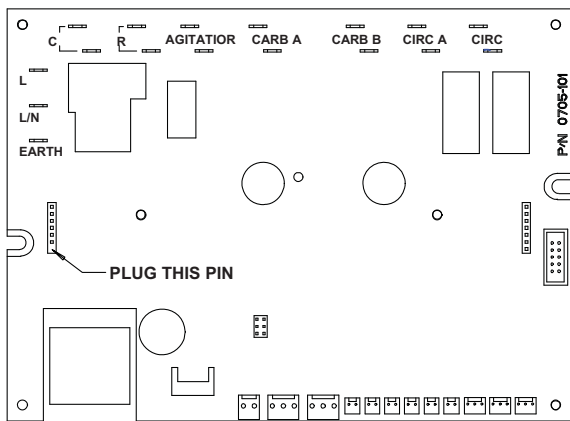

ERC CONTROL BOARD INPUT CONNENCTIONS

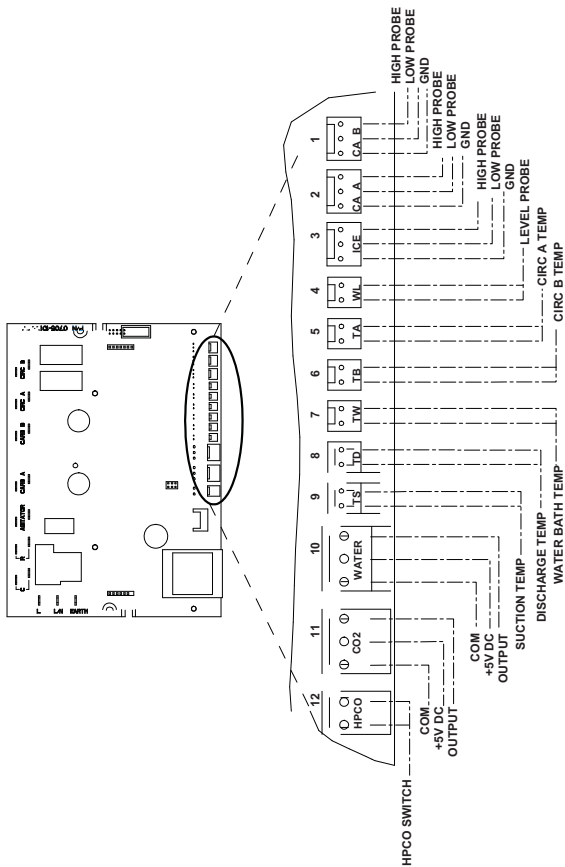

Maintenance

Maintenance Schedule

This section provides a list of periodic maintenance tasks and the scheduled frequency required to ensure the proper operation of your Multiplex dispensing equipment. To ensure quality beverages, prevent downtime, and reduce costs, these tasks must be performed as indicated.

PERIODIC MAINTENANCE FOR SOFT DRINK EQUIPMENT (LISTED BY MAJOR COMPONENTS)

Dispensing stations

Daily (365 times per year)

- Take temperature of finished drinks. Pour off the first and take the temperature of the second drink. The proper temperature of drinks must be 38°F (4°C) or less.
- Remove nozzles and diffusers from each dispensing valve. Clean with soap and warm water (not hot). Rinse with carbonated water and reinstall.
- Flush all dispenser drains. Pour hot water down drains at closing.

Beverage conduits

Every 4 months (3 times per year)

- Inspect beverage conduits for damage. Re-insulate and seal any uninsulated areas.
- Inspect floor chases and seal any open chase ends.

Air compressor

Monthly (12 times per year)

- Drain condensate water from air compressor tank.

Every 4 months (3 times per year)

- Inspect air compressor filter and replace if clogged. Air filter must be replaced every 6 months.

- Inspect air compressor to verify cut-in at 70 psi (4.8 bar) and cut-out at 90 psi (6.3 bar). Adjust pressure switch if necessary.
- Inspect system for air leaks and repair as required.

Refrigeration unit

Every 4 months (3 times per year)

- Clean the refrigeration unit air-cooled condenser using a vacuum cleaner. If equipped with water-cooled condenser, verify the water discharge temperature is at 105°F (41°C). Adjust water modulating valve if necessary.
- Inspect water bath to verify water level is at the top of stand pipe. If below, add water and repair water makeup device. If excessive amount of water is flowing over stand pipe, locate leak within bath and repair.
- Inspect ice bank within the water bath to verify proper size ice bank and clarity. Look for uniform, 2" to 4" thick ice bank.
- Drain, clean, and refill water bath.
- Inspect agitator motor and ensure proper operation.
- Inspect the circulating motor/pump assembly. Clean strainer and oil motor.
- Inspect the carbonating motor/pump assembly. Clean strainer and oil motor.
- Inspect entire system for leaks and repair as required.

Water filters

Every 4 months (3 times per year)

- Verify that incoming water pressure is not less than 40 psi (2.8 bar) or greater than 60 psi (4.1 bar). If equipped with a water regulator, verify proper setting of 55 psi (3.8 bar). Adjust if necessary.
- If pressure is low, inspect water filter cartridges to ensure they are able to supply adequate water pressure under normal system flow. Replace if unable to provide minimum 20 psi (1.4 bar) under load.

Syrup supply

Daily (365 times per year)

- Clean general area of syrup hookup with soap and warm water. Rinse off all soap.

Every 4 months (3 times per year)

- Inspect syrup lines for proper flavor identification labels. Replace labels if necessary.
- Disconnect syrup containers. Clean connector with soap and warm water. Rinse with plain water and reconnect to syrup containers.

CO₂ gas supply

Every 4 months (3 times per year)

- Inspect pressure setting at CO₂ high pressure regulator. Verify proper 90 psi (6.3 bar) pressure setting. Adjust if necessary.
- Inspect pressure setting at syrup pressure regulators. Verify proper pressure setting. Adjust if necessary.
- Inspect system for CO₂ leaks, repair as required.

PERIODIC MAINTENANCE FOR SOFT DRINK EQUIPMENT (LISTED BY SCHEDULED FREQUENCY)

Daily (365 times per year)

- Take temperature of finished drinks. Pour off the first and take the temperature of the second drink. The proper temperature of drinks must be 38°F (4°C) or less.
- Remove nozzles and diffusers from each dispensing valve. Clean with soap and warm water (not hot). Rinse with carbonated water and reinstall.
- Flush all dispenser drains. Pour hot water down drains at closing.
- Clean general area of syrup hookup with soap and warm water. Rinse off all soap.

Every 4 months (3 times per year)

- Using Brix cup and syrup separator, check for proper carbonated water flows (standard flow: 5 oz. in 4 seconds, fast flow: 10 oz. in 4 seconds)

and syrup to water ratios at each dispensing station. Adjust as required.

- Inspect beverage conduits for damage. Re-insulate and seal any uninsulated areas.
- Inspect floor chases and seal any open chase ends.
- Inspect air compressor filter and replace if clogged. Air filter must be replaced every 6 months.
- Inspect air compressor to verify cut-in at 70 psi (4.8 bar) and cut-out at 90 psi (6.3 bar). Adjust pressure switch if necessary.
- Inspect system for air leaks and repair as required.
- Clean the refrigeration unit air-cooled condenser using a vacuum cleaner. If equipped with water-cooled condenser, verify the water discharge temperature is at 105°F (41°C). Adjust water modulating valve if necessary.
- Inspect water bath to verify water level is at the top of stand pipe. If below, add water and repair water makeup device. If excessive amount of water is flowing over stand pipe, locate leak within bath and repair.
- Inspect ice bank within the water bath to verify proper size ice bank and clarity. Look for uniform, 2" to 4" thick ice bank.
- Drain, clean, and refill water bath.
- Inspect agitator motor and ensure proper operation.
- Inspect the circulating motor/pump assembly. Clean strainer and oil motor.
- Inspect the carbonating motor/pump assembly. Clean strainer and oil motor.
- Inspect entire system for leaks and repair as required.
- Verify that incoming water pressure is not less than 40 psi (2.8 bar) or greater than 60 psi (4.1 bar). If equipped with a water regulator, verify proper setting of 55 psi (3.8 bar). Adjust if necessary.

- If pressure is low, inspect water filter cartridges to ensure they are able to supply adequate water pressure under normal system flow. Replace if unable to provide minimum 40 psi (1.4 bar) under load.
- Inspect syrup lines for proper flavor identification labels. Replace labels if necessary.
- Disconnect syrup containers. Clean connector with soap and warm water. Rinse with plain water and reconnect to syrup containers.
- Inspect pressure setting at CO₂ high pressure regulator. Verify proper 90 psi (6.3 bar) pressure setting. Adjust if necessary.
- Inspect pressure setting at syrup pressure regulators. Verify proper pressure setting. Adjust if necessary.
- Inspect system for CO₂ leaks. Repair as required.

Cleaning and Sanitizing the Dispensing Valves and Product Lines

MAINTENANCE SCHEDULE

Every day	
Dispensing valves	Remove nozzles and diffusers and soak in mild detergent cleaning solution. Scrub parts with small bristle brush taking care to clean small crevices and O-ring grooves. Turn OFF power to dispensing valves. Scrub exterior surfaces, including bottom splash area and actuator lever, with cleaning solution. Reassemble diffusers and nozzles. Wipe dry exterior surfaces before turning ON power.
Drip pan and drain hose	Wash with mild detergent. Rinse with clean water.
Quick disconnects	Wash with mild detergent. Rinse with potable water.
Weekly	
Outside, dispenser cabinet	Wash with clean water and mild detergent. Wipe dry.
Every 3 months	
Syrup circuits	Sanitize each syrup circuit. See "Cleaning and Sanitizing Procedure".
Water bath	Drain, melt ice and clean using detergent and brush; rinse with potable water. Do not use water over 140°F (60°C).
Every 6 months	
Condenser	Vacuum fins or use soft bristle brush (scrub brush).
Air purifier filter (if equipped)	Replace.

CLEANING EQUIPMENT AND SUPPLIES

- **Recommended cleaner:** Any caustic-base (low sudsing, non-perfumed, easily rinsed) detergent solution which provides a minimum 2% sodium hydroxide. The solution must be prepared in accordance with the manufacturer's instructions. Solution temperature must be between 90°F (32°C) and 110°F (43°C). Temperatures in excess of this can cause internal damage to the dispensing valve components.
- **Recommended sanitizer:** Any sanitizer which provides a minimum of 120 parts per million (120 milligrams per liter) of available chlorine. Solution temperature must be between 90°F (32°C) and 110°F (43°C). Temperatures in excess of this can cause internal damage to the dispensing valve components.
- **Two five gallon (figals) syrup tanks** and fittings, cleaned and sanitized (one for cleaner; one for sanitizer)
- **Containers** for cleaner and sanitizer solutions
- **Clean, non-abrasive cloths**
- **Buckets**
- **Small Brush**
- **Extra Nozzles**
- **Extra Jumpers**

CLEANING AND SANITIZING PROCEDURE

NOTE: Cleaning and sanitizing is not required for potable water circuits. Potable water lines must remain connected and operational during the cleaning and sanitizing procedures for syrup circuits.

Caution

It is **required** that the Carbonated Water Lines remain connected and operational during cleaning and sanitizing of the syrup circuits. Sanitizing of the valve without the Carbonated Water side operation may leave bacteria in the nozzle, diffuser, and syrup tube.

Cleaning and dispensing valves

1. Disconnect each syrup container from its product line. Remove product from the lines by purging with clean warm tap water until syrup has been fully purged from the product lines and valves.
2. Clean all lines and fittings with cleaning solution and rinse with clean, room temperature water to remove all traces of residual product.

Cleaning the product lines

1. To clean each valve product line, attach the valve product lines to the pressure tank containing the cleaning solution. Make sure each line is completely filled. Pressurize the lines by pulsing the valves.

Pressurizing the product lines

- A. For 15 seconds turn dispensing valve ON, OFF, and then immediately ON again for 15 cycles.
- B. Allow the valve to remain flowing for 3 minutes.
- C. Repeat pulsing and flowing the valves again until all cleaning solution has been used.

 **Caution**

Do not allow cleaning and sanitizing solutions to remain in syrup systems longer than recommended contact time. Exceeding contact time will result in damage to valve components.

2. Flush the cleaning solution from the lines with clean water after a minimum of 3 minutes, by pulsing the valves as described above.
3. Remove the nozzles and the diffuser assemblies from the valves. Clean with cleaning solution. Agitate the assemblies to ensure assemblies are clean. Place them in a container of sanitizing solution for 15 minutes. Wearing sanitary gloves, remove the nozzles and diffuser assemblies from the sanitizing solution. Drain each until dry and reassemble to the valves.
4. Attach each valve product line to the pressure tank containing the sanitizing solution. Be sure all connections are cleaned and sanitized before connecting to each product line.
5. Pressurize and fill the lines with sanitizing solution. Make sure lines are completely filled, Allow the sanitizing solution to flow through each valve while activating the valves for 15 cycles.
 - A. Leave valves OFF and allow to stand pressurized for 30 minutes.
 - B. Activate the valves for two (2) cycles. Flush remaining sanitizer continuously through the valves.
6. Reconnect the syrup containers to their respective circuits. Prepare the unit for operation.
7. Draw drinks to refill lines and flush the sanitizing solution from the dispenser. Taste the beverage to verify that there is no off-taste (chlorine).

Sanitizing

BEVERAGE SYSTEM CLEANING

Warning

Flush sanitizing solution from syrup system.
Residual sanitizing solution left in system could create a health hazard.

Warning

When using cleaning fluids or chemicals, rubber gloves and eye protection must be worn.

Sanitize the beverage system at initial start-up as well as regularly scheduled cleaning. The drain pan must be in place under soda valves, to carry away detergent and sanitizing agents that will be flushed through valves.

BAG-IN-BOX SYSTEM SANITATION

The procedure below is for the sanitation of one syrup circuit at a time. Repeat to sanitize additional circuits.

You will need the following items to clean and sanitize the Bag-in-Box (BIB) beverage system:

- Three (3) clean buckets
- Plastic brush or soft cloth
- Mild detergent
- Unscented bleach (5% Na CL O) or Commercial sanitizer
- Bag-In-Box bag connector

1. Prepare the following in the buckets:

- Bucket 1 — warm to hot tap water for rinsing.
- Bucket 2 — mild detergent and warm to hot water.

- Bucket 3 — mix a solution of unscented bleach (5% Na CL O) or commercial sanitizer and warm to hot water. Mixture should supply 100 PPM available chlorine (1/4 oz. bleach to 1 gallon water).



2. Disconnect the “syrup-line side” of the BIB connector.

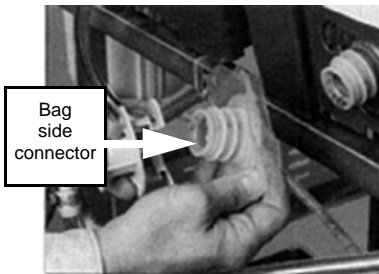

3. Rinse connector with warm tap water.

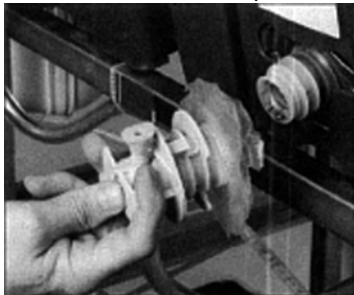

4. Connect syrup connector to BIB connector and immerse both into Bucket 1. A “bag-side” connector can be created by cutting the connector from an empty disposable syrup bag.
5. Draw rinse water through system until clean water is dispensed. Most beverage valves allow the syrup side to be manually activated by depressing the syrup pallet.
6. Connect Bucket 2 to system.
7. Draw detergent solution through system until solution is dispensed.
8. Repeat steps 2-7 until all syrup circuits contain detergent solution.
9. Allow detergent solution to remain in the system for 5 minutes.
10. Connect Bucket 3 to system.
11. Draw sanitizing solution through system until solution is dispensed.
12. Repeat step 11 until all syrup circuits contain sanitizer solution.
13. Allow sanitizer solution to remain in system for 15 minutes.
14. Remove nozzles and diffusers from beverage valves.
15. Scrub nozzles, diffusers and all removable valve parts (except electrical parts) with a plastic brush or a soft cloth and the detergent solution.
16. Soak nozzles, diffusers and removable valve parts (except electrical parts) in sanitizer for 15 minutes.
17. Replace nozzles, diffusers and valve parts.
18. Connect Bucket 1 to system.
19. Draw rinse water through system until no presence of sanitizer is detected.
20. Attach syrup connectors to BIBs.
21. Draw syrup through system until only syrup is dispensed.
22. Discard first 2 drinks.

FIGAL BEVERAGE SYSTEM

1. Prepare the following in three clean Figal tanks:
 - **Rinse tank** - fill with room temperature tap water.
 - **Detergent tank** - mix approved beverage system cleaner with warm water as directed.
 - **Sanitizing tank** - mix a solution of unscented bleach (5% Na CL O) or commercial sanitizer and warm to hot water. Mixture should supply 100 PPM available chlorine (1/4 oz. bleach to 1 gallon water).
2. Disconnect all product and water lines from product tanks and remove carbonator.
3. Locate the Figal syrup tank for the circuit to be sanitized. Remove both quick disconnects from the Figal syrup tank. Rinse quick disconnects in tap water.
4. Connect rinse tank to the syrup line. Draw clean rinse water through the valve until syrup is flushed from the system.
5. Connect detergent tank to the syrup line and draw detergent through the valve for two minutes. Then, allow remaining detergent to stay in the system for five minutes.
6. Connect rinse tank to the syrup line. Draw clean rinse water through the valve until detergent is flushed from the system.
7. Remove valve nozzle and diffuser as shown in Daily Cleaning instructions. Using a plastic brush or a soft cloth and warm water, scrub the nozzle, diffuser, bottom of the dispensing valve and cup lever, if applicable.
8. Place removable valve parts (EXCEPT solenoids) in sanitizing solution for 15 minutes.
9. Replace valve diffuser and nozzle on the beverage valve.
10. Connect sanitizer tank to the syrup line and draw sanitizer through the valve for two minutes. Allow sanitizer to remain in the system for a minimum of 15 minutes.

11. Reconnect syrup and carbonated water lines.
12. Draw syrup through the lines to rinse the system. Discard drinks until at least two cups of satisfactory tasting beverage are dispensed through the valve.

Shipping, Storage and Relocation

Caution

Before shipping, storing, or relocating this unit, syrup systems must be sanitized. After sanitizing, all liquids (sanitizing solution and water) must be purged from the unit. A freezing environment causes residual sanitizing solution or water remaining inside the unit to freeze, resulting in damage to internal components.

Operation

How the Multiplex Works

Model 2803 — a 1/3 HP refrigeration unit that will provide pre-mix carbonated beverages and chilled carbonated water for up to 6 gal (3 L) of syrup/day or 280 drinks/day (2,000 gal/yr) with a 40 ft (12 m) maximum conduit length. This is a remote refrigeration unit that derives its peak draw capacity from the reserve ice bank produced from a capillary tube refrigeration system. This system is controlled to cycle ON and OFF by the operation of the ice bank control. The sensing bulb that controls the ice bank is located on an adjustable bracket in the water bath.

Model 11M — a 1/2 HP refrigeration unit that will provide premix carbonated beverages and chilled carbonated water for up to 12 gal (45 L) of syrup/day or 560 drinks/day (4,000 gal/year) with a 100 ft (30 m) maximum conduit length. This is a remote refrigeration unit that derives its peak draw capacity from the reserve ice bank produced from a capillary tube refrigeration system. This system is controlled to cycle ON and OFF by the operation of the ice bank control. The sensing bulb that controls the ice bank is located on an adjustable bracket in the water bath.

Model 42M — a 1 HP refrigeration unit that will provide pre-mix carbonated beverages and chilled carbonated water for up to 50 gal (190 L) of syrup/day or 3,060 drinks/day (18,200 gal/yr) with a 250 ft (80 m) maximum conduit length. This refrigeration unit is a remote refrigeration unit that derives its peak capacity from the reserve ice bank produced from a TXV system. This system is controlled to cycle ON and OFF by the operation of the ice control. The sensing probe that controls the ice bank, is located on an adjustable bracket in the water bath.

Model 44M — a 1 HP refrigeration unit that will provide pre-mix carbonated beverages and chilled carbonated water for up to 50 gal (190 L) of syrup/day or 3,060 drinks/day (18,200 gal/yr) with a 250 ft (80 m) maximum conduit length. This refrigeration unit is a remote refrigeration unit that derives its peak capacity from the reserve ice bank produced from a TXV system. This system is controlled to cycle ON and OFF by the operation of the ice control. The sensing probe that controls the ice bank, is located on an adjustable bracket in the water bath.

Model 50M — a 2.2 HP Pre-mix refrigeration unit that will provide pre-mix carbonated beverages and chilled carbonated water for up to 42 gal (159 L) of syrup/day or 2,000 drinks/day (15,000 gal/yr) with a 350 ft (107 m) maximum conduit length. This refrigeration unit is a remote refrigeration unit that derives its peak capacity from the reserve ice bank produced by the operation of the compressor. This system is controlled to cycle ON and OFF by the operation of the ice bank control. The sensing bulb that controls the ice bank is located on an adjustable bracket in the water bath.

Differences Between the TS & SS Units

Multiplex soda and water chillers may have three different series numbers. Starting in 2007 some no longer begin with an “SS”; they now begin with a “TS”. Starting in 2008, units with ERC (Electronic Refrigeration Controls) end with an “E”. The following shows you how to tell the difference between the TS version and the SS.



- The TS uses common components from Manitowoc Ice makers to assist in product and parts availability.



- The TS compressor is mounted with bolts instead of studs.

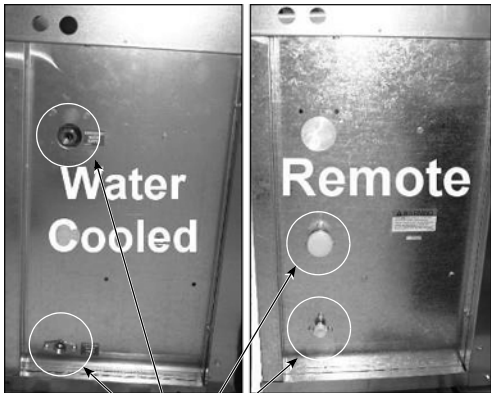

- TS remote and water-cooled back panel connections are offset to protect fittings.



- TS air-cooled condenser comes standard with a filter.

WATER MANIFOLD TS

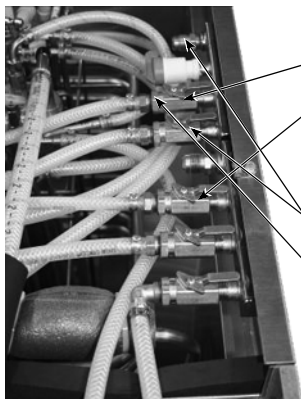

Two Stainless Steel log style manifolds

- One regulated supply for carbonator pumps.
- One unregulated supply for non-carb drinks and water bath fill.

Other Connections

- Connections are made in the water bath compartment.
- Separate plain water manifold eliminates need to plug off during installation.

ELECTRICAL TS

- Electrical compartment has been moved up on the unit to eliminate water intrusion potential from the pump compartment.
- All components are now 208/230V. This eliminates the need for a neutral wire.

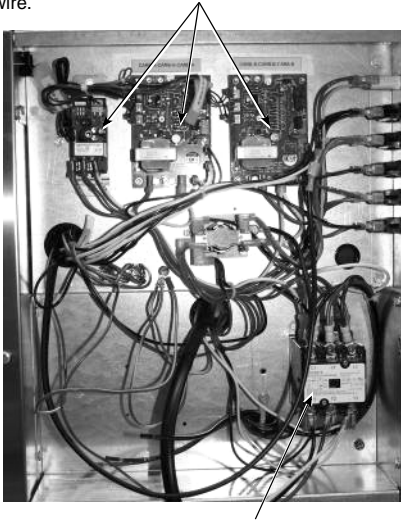

- New unit has service connections in the electrical compartment. Allows more room to work and more reliable connection.



- Pump protection switch has been moved to the pump compartment to eliminate potential leak point in electrical compartment.

WATER BATH ACCESS SS

- Has a round hole in the front and back panels with no edge trim to protect lines.

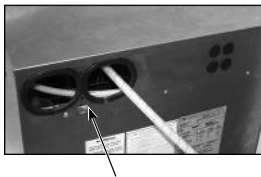
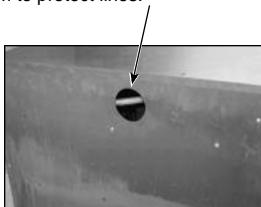

- End panel has two ovals in the rear of the panel with edge trim to help protect conduit lines.

WATER BATH ACCESS TS



- All panels have large oval access holes with interchangeable covers.
- Front panel has 3 hole cover for water and CO₂ line routing.
- Back panel has solid cover.
- End panel has one open cover and one solid cover.
- Open cover provides wide ledge for conduit line protection.

SERVICE ACCESS SS

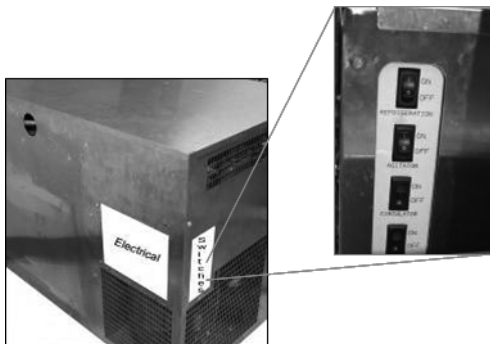

- Front panel was solid and did not allow easy access for service.
- Switch panel was mounted flush to end panel.

SERVICE ACCESS TS

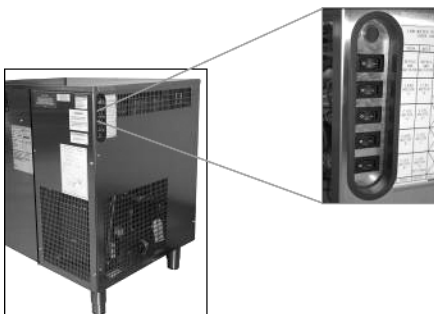

- Front panel is split to allow front access to the compressor compartment.
- Switches are recessed and the edge has trim panel to protect fingers from sheet metal edges.

SERVICE ACCESS TS WITH ERC

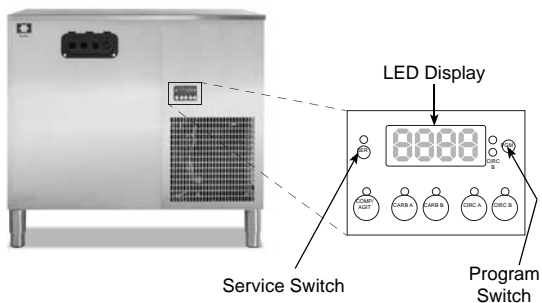

- Service Switch — (SER) switch, press to send ID on power line network.
- Wink Function — LED flashes “1on” to indicate wink function. Press program switch (PGM) to disable wink function.

Equipment Setup Procedure (Non-ERC)

1. Ensure that all valve nozzles are attached to the valves.
2. Observe pressure of CO₂ high pressure tank of 500 psi (34 bar) or more, or bulk CO₂ tank of 150 psi or more. Primary regulator set at 90 psi (6 bar) and the secondary regulator set at 35 psi (2.4 bar).
3. Observe the control panel to verify that all pressure gauges are set at correct operating pressures.
4. Check the syrup tanks to make sure a sufficient number of tanks are connected in series to satisfy business volume.
5. Clean syrup inlet and outlet quick disconnects at the same time tanks are replaced. Rinse disconnects in clean potable water.

Start-up (Non-ERC)

1. Fill the refrigeration unit water bath tank with water to within 1/2" (1.27 cm) of the top of the overflow tube.
2. Open the manual water shut-off valve to the water cooled condenser (if applicable).
3. Turn ON the rocker switch labeled "Refrigeration" to begin building an ice bank.
4. Turn ON the rocker switch labeled "Agitator".

NOTE: On TS units 3 & 4 are combined into 1 switch.

5. Ice will begin to form on the evaporator coils in approximately 2 hours.
6. The refrigeration unit will build an ice bank in approximately 4 to 6 hours.
7. If optional CO₂/Water Control Panel has been installed on the refrigeration unit, refer to the installation instructions for operation and testing the circuits for leaks.
8. The carbonation circuits "A" and "B," as well as the syrup circuits must be checked for leaks and possible cross circuits before turning ON the water supply to carbonator pumps.
9. Turn on main water supply. Set incoming regulator to 55 psi on the CO₂ panel; 25 psi for the Model 11M root beer system's internal regulator (must be lower than CO₂ supply pressure). Once water is supplied to the unit, air needs to be purged from the carbonator tank. Do so by lifting press relief valve tab until water comes out of relief valve.
10. Turn on main CO₂ supply. Set regulator initially to 90 – 100 psi. For the Model 11 Root Beer system, set regulator initially to 26 psi; it can be raised incrementally to 30 psi if there is excessive foaming.
11. Set bag-in-box syrup tank push pressure CO₂ regulator to 65 – 70 psi. For the Model 11 Root Beer system, set push pressure CO₂ regulator to 35 – 40 psi.

PLACING THE CARBONATION SYSTEM IN OPERATION

1. Open the CO₂ gas supply valve at CO₂ tanks or bulk tank. Adjust the CO₂ pressure to 90 psi (6.2 bar).
2. Open relief valve on top of the carbonator tank for 4 seconds to bleed off air in tank.
3. Turn ON the water supply to unit.
4. Turn ON the switch labeled "Carbonator Pump". Allow carbonator to run and cycle OFF.
5. Activate all valves until a smooth, continuous flow of carbonated water and non-carbonated water appear at the valves.
6. Turn ON switch labeled "Circulator".
7. Allow at least 1 hour before proceeding to calibration instructions. You may complete the sanitizing instructions during this period.

Sequence of Operation (Non-ERC)

PRE-MIX REFRIGERATION UNIT

Ice Bank Is Required

1. Check water bath for full ice bank.
2. The stabilized water bath operating temperature must be maintained at 33°F (0.6°C) to 35°F (1.7°C).

The following is a sequence of operations for the Multiplex Pre-mix Beverage equipment.

1. Once a drink is dispensed, the following will occur:
 - A. For a Syrup Tank System, the Pre-mix syrup is manually mixed at the store. Pre-mix beverage is then transferred to a holding tank for supply to the Multiplex system.
 - B. For a Bag-In-Box System, pre-mix syrup is drawn from a Bag-In-Box by means of a gas driven syrup pump.
2. The carbonator pump (stainless) pulls the 5:1 pre-mix out of the 3 gallon holding tank and injects it into the pre-mix carbonator tank where the CO₂ pressure is 35 psi (2.4 bar) on the tank.
3. The circulator pump runs continuously and circulates water bath water through the conduit to provide cooling for all drinks.

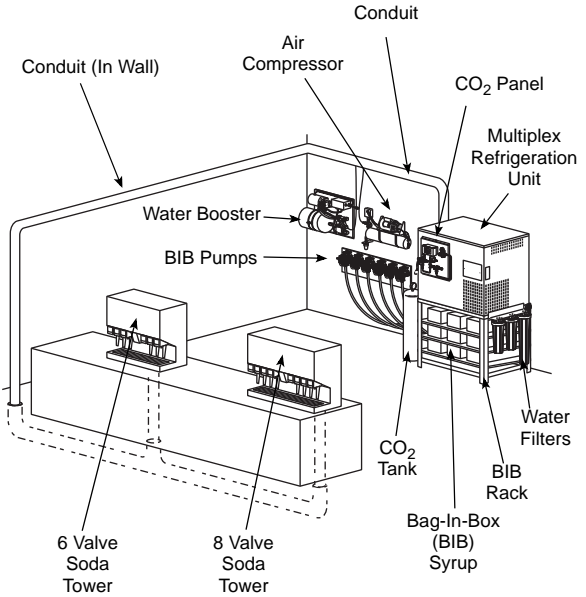

Multiplex Pre-mix Beverage System Operation and Layout

Start-up (with ERC)

PLACING EQUIPMENT IN OPERATION

Before placing equipment in operation, verify that all requirements for roof mounted Remote Condenser Units (if applicable) have been satisfied. Refer to the instructions on installing the Remote Condenser.

Verify proper supply power to unit.

1. Fill the refrigeration unit water bath tank with water to within 1/2" (1.27 cm) of the top of the overflow tube.
2. Open the manual water shut-off valve to the water cooled condenser (if applicable). Refer to "Electronic Control" for control programming sequence.
3. Press "Comp/Agit" to begin building an ice bank.
4. Ice will begin to form on the evaporator coils in approximately 2 hours.
5. The refrigeration unit will build an ice bank in approximately 4 to 6 hours.
6. If optional CO₂/Water Control Panel has been installed on the refrigeration unit, refer to the installation instructions for operation and testing the circuits for leaks.
7. The carbonation circuits "A" and "B," as well as the syrup circuits must be checked for leaks and possible cross circuits before turning ON the water supply to carbonator pumps.
8. Turn on main water supply. Set incoming regulator to 55 psi on the CO₂/Water control panel. Once water is supplied to the unit, air needs to be purged from the carbonator tank. Do so by lifting press relief valve tab until water comes out of relief valve.
9. Set bag-in-box syrup tank push pressure CO₂ regulator to 60 psi.

PLACING THE SYRUP SYSTEM IN OPERATION

1. Open the CO₂ gas supply valve at CO₂ tanks or bulk tank. Adjust the CO₂ pressure to 90 psi (6.2 bar).
2. Open relief valve on top of the carbonator tank for 4 seconds to bleed off air in tank.
3. Verify the water supply to unit is on.
4. Press the switch labeled "Carb A" (and B if applicable). Allow carbonator to run and cycle OFF.
5. Press the switch labeled "CIRC A" (and "CIRC B" if applicable).
6. Activate all vales until a smooth, continuous flow or carbonated water and non-carbonated water appear at the valves.
7. Allow at least 1 hour before proceeding to calibration instructions. You may complete the sanitizing instructions during this period.

Sequence of Operation (with ERC)

ELECTRONIC CONTROL

Prerequisites

- Potable water must be connected to the carbonator pump circuit.
- The ice bank water bath water must cover the evaporator. The compressor will not start unless the ice bank control probes are immersed in water.
- CO₂ must be supplied.

Initial Power-up

The control has a 30-second delay when power is connected, or disconnected and reconnected. The display will show Pd30 - power delay and 30 seconds left in the countdown cycle.

Normal Two Circuit Operation

Pressing the COMP/AGIT button will start the water bath agitator immediately and initiate the 180 second compressor delay. The display will show Cd99 (compressor delay & 99 seconds) and will start to count down from 99 seconds after the first 81 seconds have elapsed. After 180 seconds the compressor and condenser fan motor energize and the COMP/AGIT LED flashes. Pressing the CARB A and CARB B buttons will power the carbonator tank liquid level control. The corresponding LED flashes to indicate the pump is running. Pressing the CIRC A & CIRC B buttons will immediately energize the circulating pumps and energize the LED constantly. The display will show the circulating temperature and show the A circuit. When two circuits are used the readout will alternate between A and B circuits every 5 seconds.

The compressor and condenser fan will continue to run until ice contacts the ice bank control probe closest to the evaporator. When ice contacts the probe, the COMP/AGIT LED lights constantly and the compressor and condenser fan motor de-energize.

As the ice bank melts, the ice bank control probe will lose contact with the ice; the LED will flash and the compressor and condenser fan motor will restart. This cycle will repeat as required depending on load.

Power Interruption

During a power interruption the control will resume from the point of interruption when power is reapplied and the time delay expires. Any switches/components that were energized when power was interrupted will be energized when power is reapplied.

Error Codes

- E1 = Low Water Supply Pressure
- E2 = Low CO₂ Pressure
- E3 = Low Water Level - Water Bath
- E4 = High Water Bath Temperature
- E5 = High Water Supply Pressure
- E6 = High Refrigeration Temperature
- E7 = High Ice Bank Size (Probe Sensor 2)
- E8 = Long Carb A Run Time
- E9 = Long Carb B Run Time

NOTE: Shorted Transducer = "----"

Open Transducer = "===="

Error codes will display until corrected.

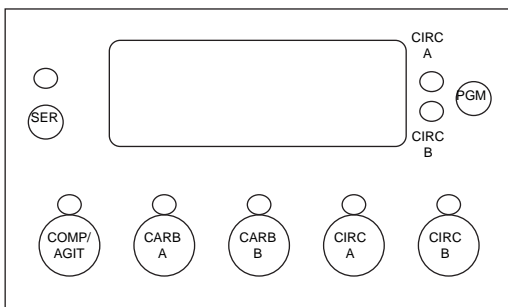

Control Programming

SER Switch

- For when optional LON communication network is connected.

PGM Switch

- Used to enter and exit programming modes.
- Press **PGM** Switch **F000** will display
 - Press and hold Carb A switch — Display will indicate **Water Bath Temperature**
 - Press and hold Circ A switch — Display will indicate **Discharge Temperature**
 - Press and hold Circ B switch — Display will indicate **Suction Temperature**
- Press **PGM** Switch **P000** will display
 - Press and hold Carb A switch — Display will indicate **Water Pressure**
 - Press and hold Carb B switch — Display will indicate **CO2 Pressure**

Press and hold PGM switch for 3 seconds to save settings and exit program mode.

Program Mode 1

To enter, press and hold switch for 3 seconds.

- **0001** will display indicating Mode 1
- Wait 3 seconds — **C000** will display
- Press and hold Carb A switch — Display will indicate one of the following:
 - **CA00** — Low and High Probes are open (carbonator motor is energized)
 - **CA11** — Low and High Probes are closed (carbonator motor is de-energized)
 - **CA01** — Low Probe closed (Motor will still be on)

- Press and hold Carb B switch — Display will indicate one of the following:
 - **Cb00** — Low and High Probes are open (carbonator motor is energized)
 - **Cb11** — Low and High Probes are closed (carbonator motor is de-energized)
 - **Cb01** — Low Probe closed (Motor will still be on)
- Press and hold COMP/AGIT switch — Display will indicate one of the following:
 - **CL 0** — Water level low
 - **CL 1** — Water level OK

Program Mode 2

Add circulation pumps C & D.

- Press PGM button for 3 seconds — Display shows **0001**.
- Press PGM button — Display shows **0002** program mode 2.
- Wait 3 seconds — Display shows **-002** = Factory default setting.
 - Pressing CIRC A button energizes/de-energizes pump A
 - Pressing CIRC B button energizes/de-energizes pump B
- Program CIRC C — Press CARB A button – Display shows **-102** = Carb A button energizes/de-energizes pump C
- Program CIRC D — Press CARB B button - Display shows **-012** = Carb B button energizes/de-energizes pump D

Press and hold PGM switch for 3 seconds to save settings and exit program mode.

Program Mode 4

Temporarily cancel display of error codes. Cancelling the error codes allows circulating glycol temperatures to be displayed until the error can be corrected.

- Press PGM button for 3 seconds — Display shows **0001**.
- Press PGM button three times — Display shows **0004** program mode 4.
- Wait 3 seconds — Display shows **-004** = All error codes will be displayed during run mode.
- Press COMP/AGIT button once — Display shows **---4** = error codes will not be displayed during run mode.

NOTE: Disconnecting and reconnecting main power will reset the control board to the factory setting **-004** = Error codes will be displayed in the run mode.

Equipment Setup Procedure (with ERC)

1. Ensure that all valve nozzles are attached to the valves.
2. Observe pressure of CO₂ high pressure tank of 500 psi (34 bar) or more, or bulk CO₂ tank of 150 psi or more. Primary regulator set at 90 psi (6 bar) and the secondary regulator set at 35 psi (2.4 bar).
3. Observe the control panel to verify that all pressure gauges are set at correct operating pressures.
4. Check the syrup tanks or BIB to make sure a sufficient number of tanks are connected in series to satisfy business volume.
5. Clean syrup inlet and outlet quick disconnects at the same time tanks are replaced. Rinse disconnects in clean potable water.

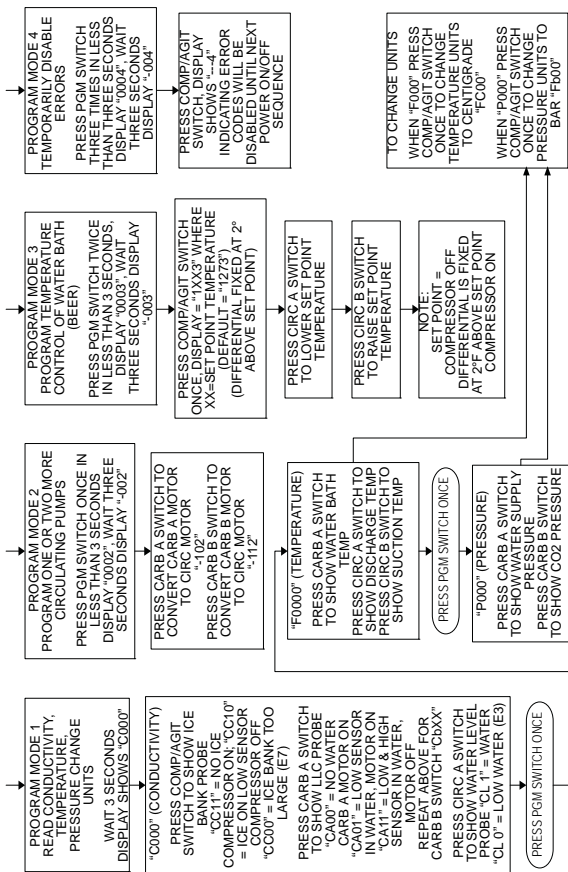

Equipment Close Procedure — All Units

1. Clean the underside of the dispensing tower around the nozzle area with a clean damp towel.
2. Pour at least 60 oz (1.8 liters) of warm water down the drain openings.

MULTIPLEX ELECTRONIC REFRIGERATION CONTROL (ERC) PROGRAMMING

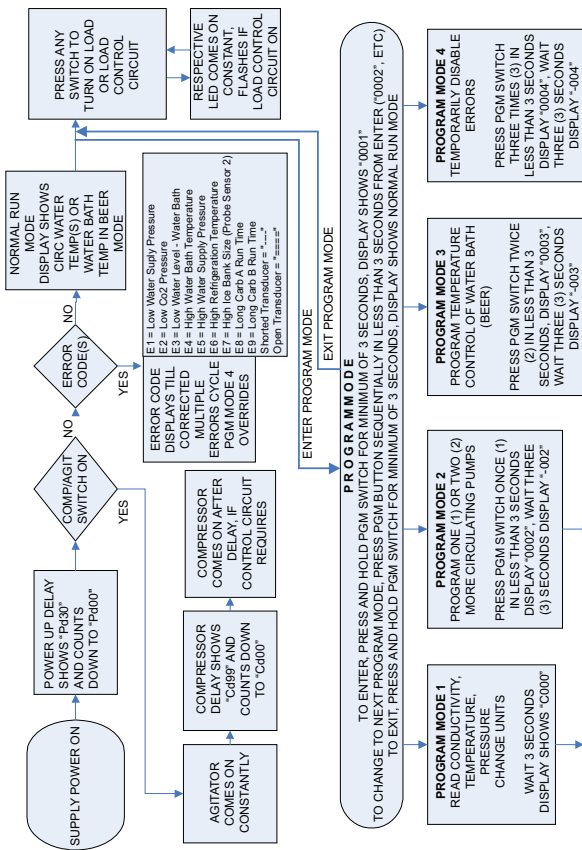

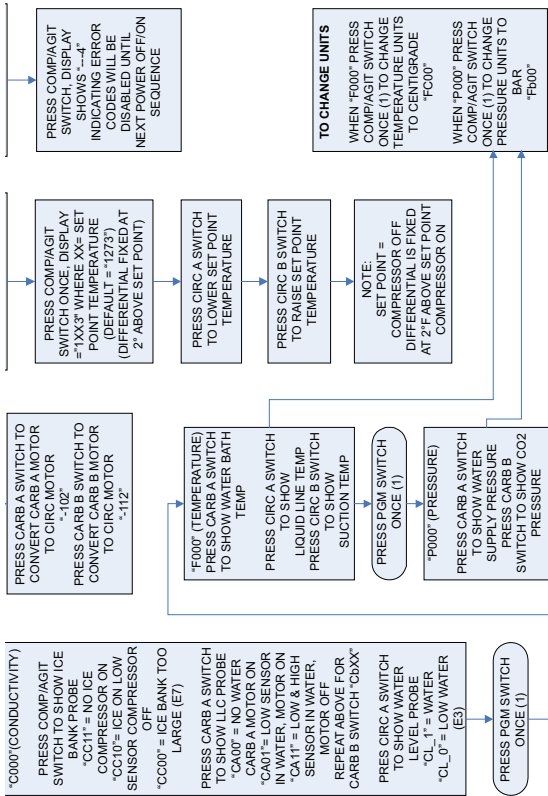

Troubleshooting

Electronic Refrigeration Control (ERC) Model Error Codes

- Error codes will interrupt the temperature display and stay active until the error is corrected.
- If multiple errors are present, the errors will rotate and display every 5 seconds.
- Resetting errors — After correcting the problem, the respective switch for the error must be cycled OFF and then ON to reset.
- Disconnecting and reconnecting power will erase all errors.

Error Code	Error	Cause
E1	Low Water Supply Pressure	Lower than 5 psi for 5 Seconds
E2	Low CO ₂ Pressure	Lower than 10 psi for 5 Seconds
E3	Low Water Level – Water Bath	Must Cover Top of Evaporator
E4	High Water Bath Temperature	Water Bath Temperature Greater Than 45°F
E5	High Water Supply Pressure	Water Pressure Greater than 75 psi
E6	High Refrigeration Temperature	Discharge Line Temperature Greater than 190°F
E7	High Ice Bank Size	Ice Contacting Center Ice Bank Probe
E8	Long Carb A Run Time	Energized for 7 Continuous Minutes
E9	Long Carb B Run Time	Energized for 7 Continuous Minutes

ERROR CODES E1, E2, & E3 FLOWCHART

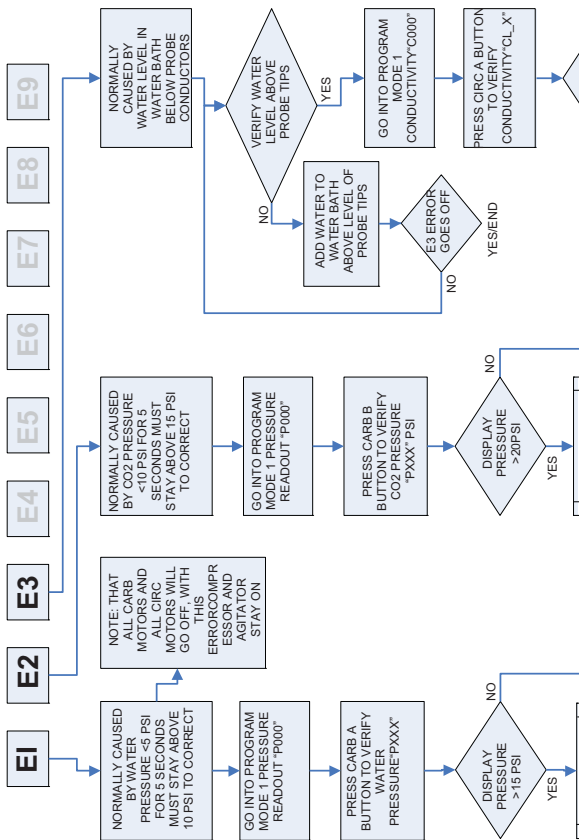

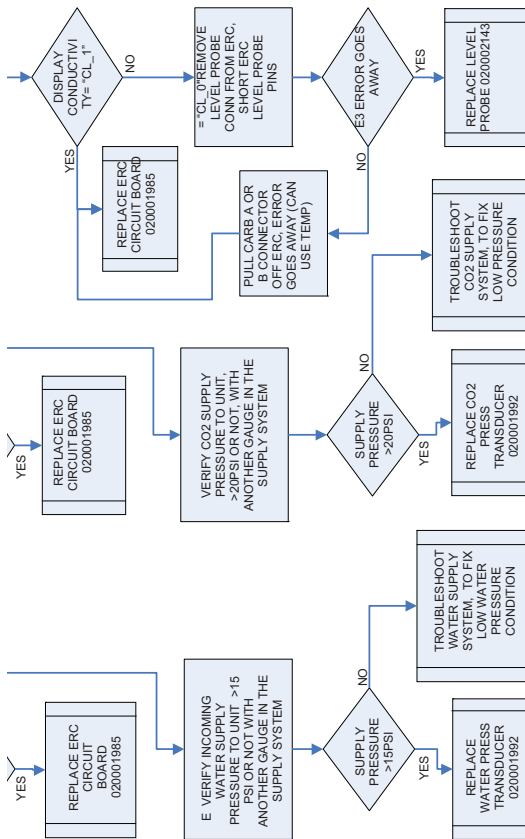

ERROR CODES E4, E5, & E6 FLOWCHART

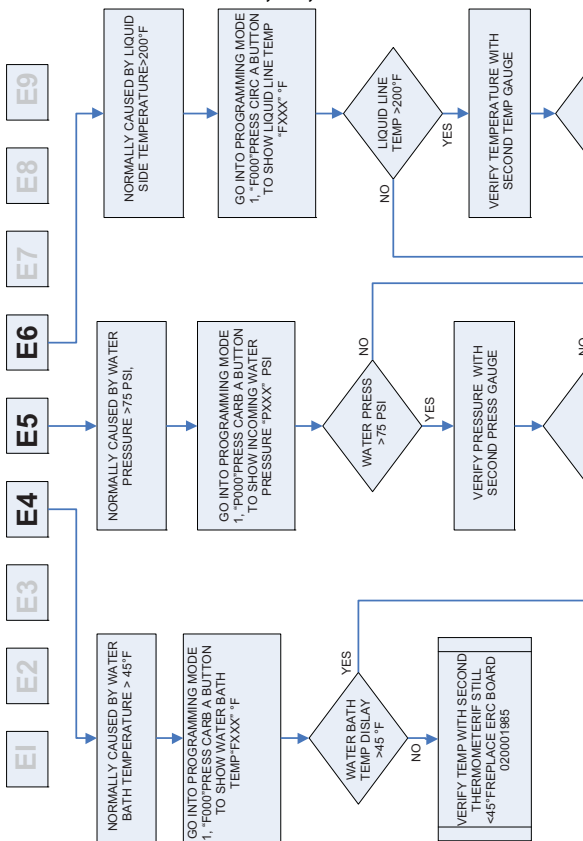

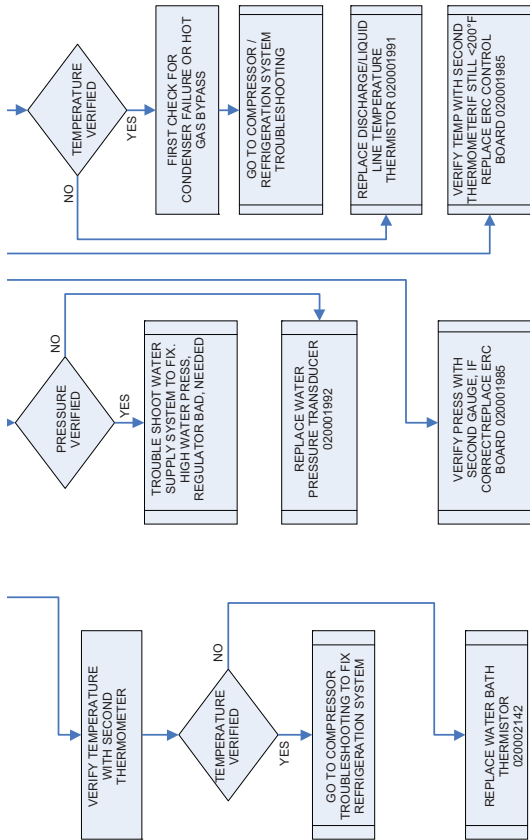

ERROR CODES E7, E8, & E9 FLOWCHART

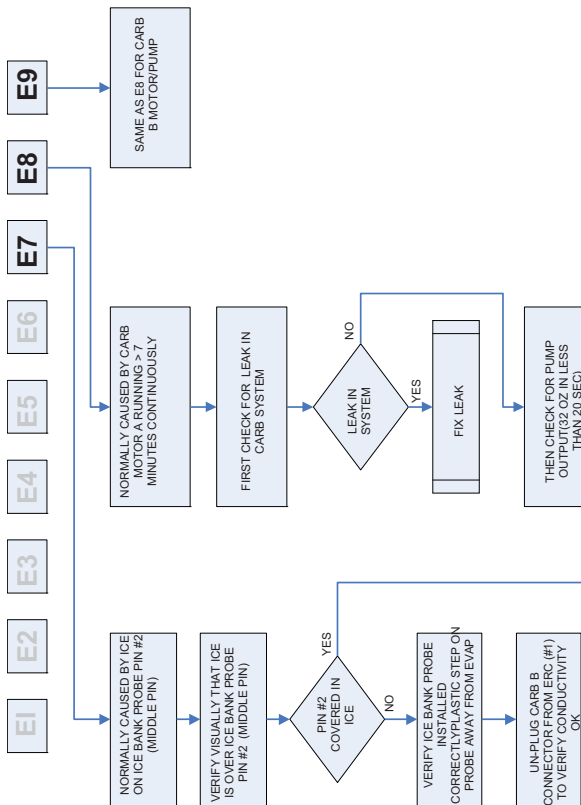

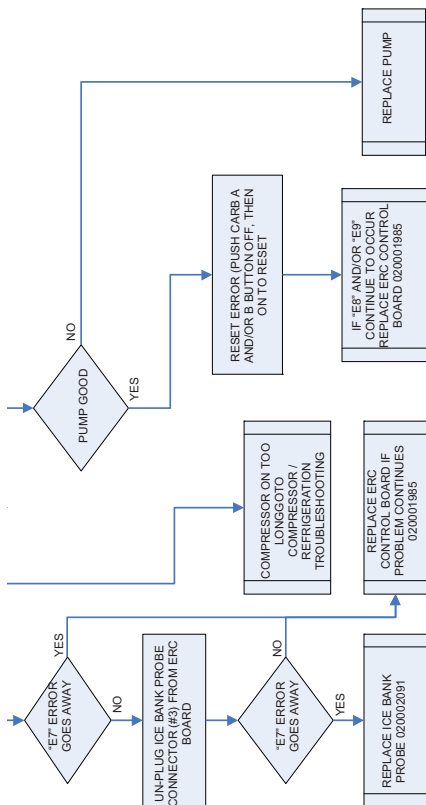

COMPONENT TROUBLESHOOTING

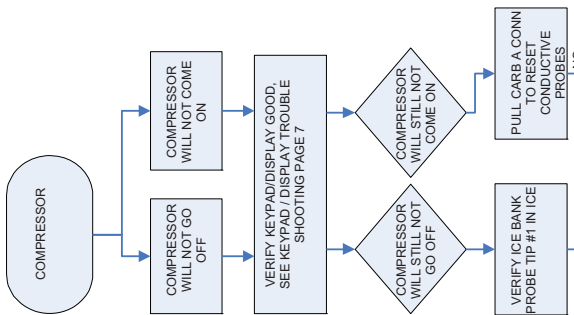
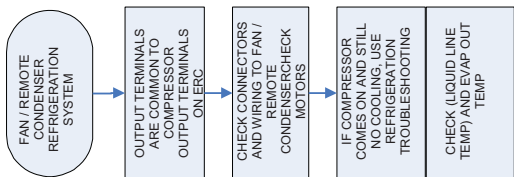
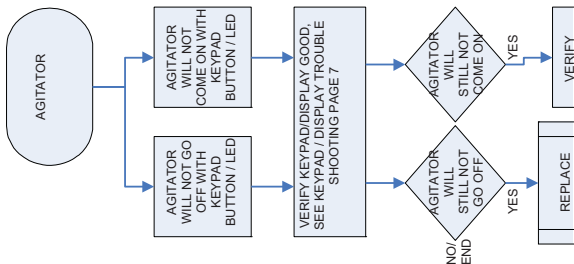

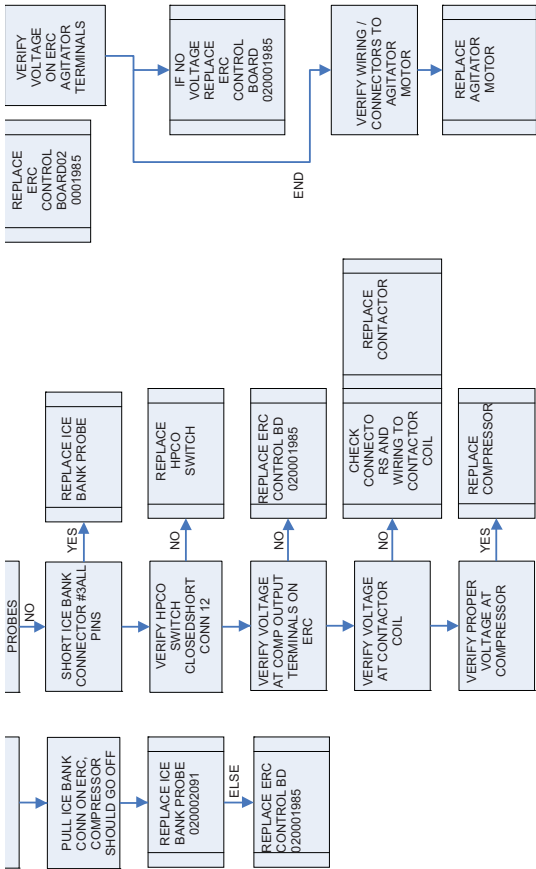

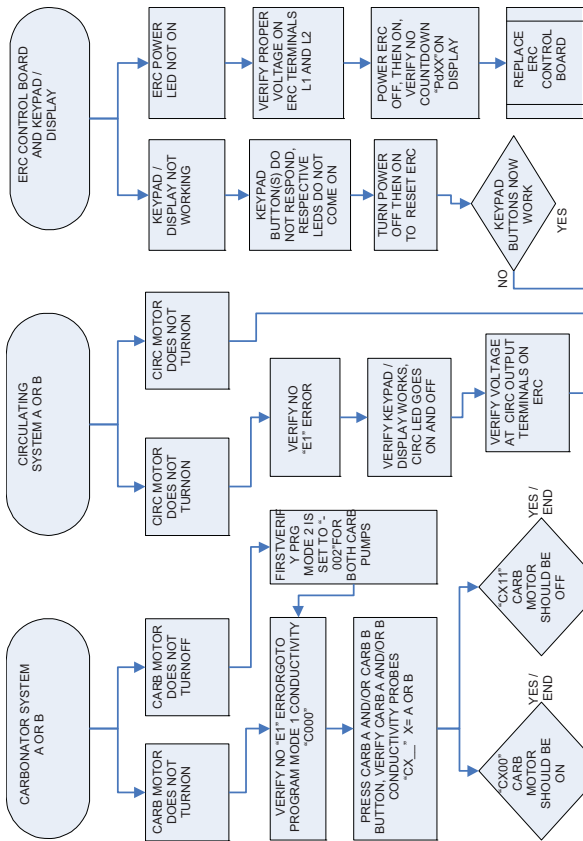

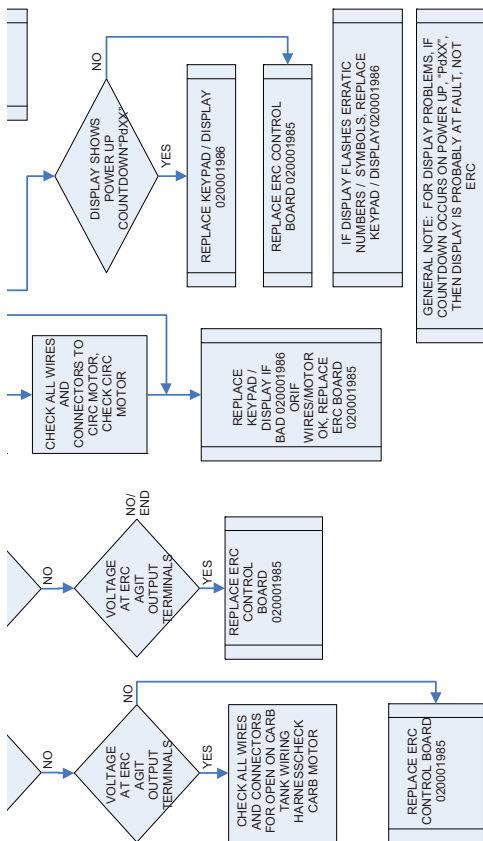

Checklist

If a problem arises during operation of your post mix soda refrigeration unit, follow the checklist below. Routine adjustments and maintenance procedures are not covered by the warranty.



Warning

Only trained and certified electrical and plumbing technicians must service this unit. All wiring and plumbing must conform to national and local codes.

Problem	Possible Cause	To Correct
Water only dispensing: No pressure	Regulator(s) out of adjustment	Check/adjust regulator(s).
	Out of CO ₂	Install fresh tank.
	Defective regulator(s)	Check/repair/replace regulator(s).
	CO ₂ line pinched, kinked, or obstructed	Check/repair/replace CO ₂ line.
Syrup and CO ₂ only dispensing: Carbonator	No power	Check power supply. Plug in carbonator or reset breaker.
	Water supply	Make sure water is turned ON.
		Replace water filter.
		Check/clean/replace pump strainer.
		Check/clean/repair water check valve.
	Check for frozen water line. Internal Carbonator unit only.	
Defective carbonator	Check/repair/replace carbonator pump, motor, electrode or liquid level control.	
Syrup and plain water only dispensing: No pressure	Out of CO ₂	Install fresh tank.
	HP regulator out of adjustment	Adjust HP regulator to the proper setting.
	Defective HP regulator	Check/repair/replace HP regulator.
	CO ₂ line pinched, kinked, or obstructed	Check/repair/replace CO ₂ line.
One valve will not dispense anything: Is there power to the valve?	Broken wire or loose connection	Replace/repair wire or connector.
	Bad microswitch	Replace microswitch.

Problem	Possible Cause	To Correct
Beverage dispensed is too sweet: Is the ratio (brix) of the drink correct?	Flow control out of adjustment	Adjust the flow control.
	Insufficient soda flow due to low carbonator pressure	Adjust CO ₂ pressure or change the tank.
	Low CO ₂ pressure due to leaks	Repair CO ₂ leaks.
	Obstruction in the water or soda line	Clean out the lines.
Beverage is not sweet enough: Is the ratio (brix) of the drink correct?	Flow control out of adjustment	Adjust the flow control.
	Soda flow too high	Reset CO ₂ pressure or replace regulator if necessary.
	Obstruction in syrup line	Clean out the syrup line.
Drinks are foaming: Are system pressures correct?	Over carbonation	Check CO ₂ supply. Reset pressure or replace regulator is necessary.
	Dirty lines/valves	Clean/sanitize entire system.

Problem Cross-reference Guide

	CO ₂	Carbonated	Circulating	Compress Air	Dispenser	Electrical	Refrigeration	Syrup	Water Booster	Water Filter
No carbonated water		X	X		X		X			
Carbon particles in drink		X	X							X
Flat drinks	X	X	R				R		X	
No or insufficient non-carbonated water					X		X		X	
Warm drinks			X							R
No or insufficient syrup				X	X		R	X		
Peculiar taste carbonated water		X								R
Peculiar taste non-carbonated water		R							X	R
Peculiar taste syrup				X				X		R
Carb and booster pump noisy		R							R	X
Air compressor operates excessively				X				R		
Loss of CO ₂ gas	X							R		
Drinks too sweet					R			X		
Too much syrup					X			R		
Too much carbonated water					X					
Too much non-carbonated water					X			R		
Foaming					X		R			
Booster pump/motor won't cycle OFF								X		
Booster pump/motor won't cycle ON								X		
Excessive Carbonation	X									
Low pressure CO ₂ alarm won't cycle ON	X									
Low pressure CO ₂ alarm won't cycle OFF	X									
Water found in primary regulator	X									
Booster pump/motor won't cycle OFF		X								
Booster pump/motor won't cycle ON		X								
Product dripping from nozzle					X					
Valves will not activate					X					
Valves will not shut OFF					X					
Unit totally inoperative						X				

X - Specific problem listed in section

R - Problem refer to from section with "X"

CO₂ Gas System

On units not equipped with Air Pump, check all **Probable Causes** listed below.

Qualifier	Probable Cause	Corrective Action
Loss of CO₂		
If leak occurs while Change-over valve is positioned on Air, follow the "Probable Causes" (for units equipped with Air Pump).	CO ₂ Tank leaking.	Use a soap solution around CO ₂ Tank valve Stem to locate leaks. If leaks are present, bubbles will appear. If valve Stem leaks at Tank, replace CO ₂ Tank.
	CO ₂ Washer damaged or missing.	Use a soap solution around Primary Regulator Coupling Nut and CO ₂ Tank Stem. If bubbles appear, remove Regulator and replace CO ₂ Washer found inside Nut. Secure Regulator to Tank and check for leaks.
	Primary Regulator Diaphragm leaking.	Use a soap solution around Primary Regulator Adjustment Screw in Bonnet. If bubbles appear, diaphragm is leading. Replace Primary Regulator.
	Ruptured Line Assembly or leaks at connections.	Use a soap solution around all connections. If bubbles appear, tighten loose connections carefully.
	A to B Change-over Valve leaking.	Use a soap solution around A and B CO ₂ Tank Change-over Valve, tighten if bubbles appear at Connections to stop leaks.
	CO ₂ Low Pressure Switch leaking.	Use a soap solution around Low Pressure CO ₂ Switch. If bubbles appear at pipe, tighten Connection. If bubbles appear at Terminal end of Switch - replace Switch.
	CO ₂ Check valve leaking.	Use a soap solution around Check valve. If bubbles appear, tighten Connection to stop leaks.
	Back Flow Preventer stuck open.	Use a soap solution around Back Flow Preventer. Tighten if bubbles appear at connection. If bubbles appear at Vent Hole on underside of Back Flow Preventer, clean out or replace Back Flow Preventer valve and corresponding Water Check valve.
	Carbonator Tank Relief valve leaking.	Use a soap solution around Relief valve. If bubbles appear, replace Relief valve.
If leak occurs only while Change-over valve is positioned on CO ₂ , refer to Troubleshooting "Syrup System".	Gas leak at the syrup system.	Refer to Troubleshooting "Syrup System" under No syrup or insufficient syrup in finished drink.

Qualifier	Probable Cause	Corrective Action
<i>Flat drinks (lack of carbonation in carbonated water)</i>		
Primary Regulator (less than 500 psi [34.5 bar]).	CO ₂ Supply exhausted (CO ₂ Tank is functionally empty if pressure reads less than 500 psi [34.5 bar]).	Verify CO ₂ Tank pressure is a minimum of 500 psi (34.5 bar) on the Primary Pressure Regulator Gauge marked 0-2000 psi. Replace tank if necessary.
	Primary Regulator out of adjustment or inoperative.	Verify CO ₂ Primary Regulators are set at 90 psi (6.3 kg/cm ²). Adjust if necessary. If Regulator will not stay in adjustment, replace Regulator.
CO ₂ Supply adequate (greater than 500 psi [34.5 bar]).	A and B CO ₂ Tank Change-over Valve incorrectly positioned.	If A and B CO ₂ Tank Change-over Valve is positioned on an empty Tank or halfway between A and B operating positions, CO ₂ is not supplied to Carbonators. Ensure valve handler is in the "operating" position.
	Malfunition of the Refrigeration System.	Refer to Troubleshooting "Refrigeration System" under Warm drinks .
	Water Filter restricted.	Refer to Troubleshooting "Water Filter System" under Peculiar taste .
	Malfunition of the Carbonated Water System.	Refer to Troubleshooting "Carbonated Water System" under Flat drinks .
Excessive carbonation (foaming).	Primary Regulators set too high.	Verify CO ₂ Primary Regulators are set at 90 psi (6.3 kg/cm ²). Adjust if necessary. If Regulator will not stay in adjustment, replace regulator. Replace.
Low Pressure CO ₂ Warning light or buzzer does not come ON .	Warning lamp or buzzer burned out. Transformer inoperative.	When CO ₂ Tank is empty and CO ₂ warning lamp(s) or buzzer fail, verify voltage across Transformer. If no voltage, replace Transformer.
	Pressure Switch defective.	If CO ₂ Warning lamps or buzzer and transformer are operative. Pressure Switch is defective and must be replaced.

Qualifier	Probable Cause	Corrective Action
<i>Flat drinks (lack of carbonation in carbonated water) (continued)</i>		
Low Pressure CO ₂ Warning light or buzzer does not go OFF .	Leaks on system.	If leaks exist on CO ₂ System, not enough pressure is maintained to allow Pressure Switch to cut OFF CO ₂ Warning light or buzzer. Use a soap solution to located possible leaks. Tighten connections carefully.
	Primary Regulator out of adjustment.	Check CO ₂ supply. The Primary Regulators must be set at 90 psi (6.3 kg/cm ²). Adjust if necessary. If regulator will not stay in adjustment, replace regulator.
	Pressure Switch inoperative.	Carefully disconnect one wire from the CO ₂ Pressure Switch, if CO ₂ Warning Lamps go out, the CO ₂ Pressure Switch is defective and should be replaced. Carefully disconnect one wire from the CO ₂ Pressure Switch, if CO ₂ Warning Lamps go out, the CO ₂ Pressure Switch is defective and should be replaced.
Water found in CO ₂ Regulator and lines.	CO ₂ Check Valve defective.	Turn CO ₂ OFF at CO ₂ Tank valve. Remove top Cover from Remote Refrigeration Unit. Locate CO ₂ Check valve on top of Carbonator Tank. Remove CO ₂ line on Inlet side of Check Valve. If CO ₂ is present, escaping from Carbonator Tank, clean out or replace Check valve.

Carbonated Water System

Qualifier	Probable Cause	Corrective Action
Flat drinks		
Malfunctioning of Refrigeration System.	Beverages at dispensing tower are above 40°F (5°C).	Refer to Troubleshooting "Refrigeration System" under Warm drinks .
Malfunctioning of Circulating System.		Refer to Troubleshooting "Circulating System" under Warm drinks .
Beverages at dispensing tower are below 40°F (5°C).	CO ₂ supply exhausted.	Verify CO ₂ Tank pressure is a minimum of 500 psi (35 kg/cm ²) on Primary Pressure Regulator Gauge marked 0-2000 psi. Switch to full tank if necessary.
		Ensure CO ₂ Shut-off Valves to Carbonators are both in the ON position. Refer to Troubleshooting "CO ₂ Gas System" under Flat drinks .
	Primary CO ₂ Regulator out of adjustment or inoperative.	Verify CO ₂ Primary Regulators are set at 90 psi (6.3 kg/cm ²). Adjust if necessary if Regulator will not stay in adjustment replace Regulator.
	Water Regulator incorrectly adjusted or inoperative.	Verify Filtered Water Pressure Gauge registers 55 psi (3.9 kg/cm ²), if higher than 55 psi, flooding of Carbonator will occur. To adjust, loosen Locknut, turn Adjustment Screw clockwise to increase, counterclockwise to decrease. If regulator will not respond to adjustments, replace regulator.
	Improper water treatment.	Verify By-pass handle is in the "filter operating" position. Ensure Filter Cartridge is still effective, if necessary replace Cartridge. Refer to Troubleshooting "Water Filter System"
	Carbonator Pump worn (Brass pump).	Dispense Carbonated Water while listening for carbonator pump and motor to cycle ON at Refrigeration Unit. Pumps should operated between 6 to 12 seconds before cycling OFF . If operating time exceeds 30 seconds carbonator pump is worn, replace Pump.
	Pressure Relief Valve is leaking.	Remove top cover from Remote Refrigeration Unit. Dispense Carbonated Water until carbonator Pumps and Motor cycle ON . Observe Pressure Relief Valves on carbonator Tank. If water is observed escaping from either, replace leaking Relief valve. Note: Do not confuse the Water Bath Make-up valve for the carbonator Tank Relief valves.

Qualifier	Probable Cause	Corrective Action
Beverages at Dispensing Tower are below 40°F (5°C). (continued)	Back Flow Preventer.	Remove top cover from Remote Refrigeration Unit. Use a soap solution around Back Flow Preventer. If bubbles appear at Vent Hole or underside of Back Flow Preventer, clean or replace Back Flow Preventer and corresponding Water Check valve carbonator Tank.
	Double Check valve (water) stuck open.	With top cover from Remote Refrigeration Unit removed and carbonator Pump Switch and Water turned OFF , loosen water supply line at inlet side of Double Check valve Assembly. If CO ₂ gas escapes from Check valve, it must be cleaned or replaced.

Qualifier	Probable Cause	Corrective Action
<i>No carbonated water at any of the dispensing valves</i>		
No CO ₂ gas or water present at dispensing valves.	Malfunction of Refrigeration System.	Refer to Troubleshooting "Refrigeration System" under No carbonated water at any of the dispensing valves (freeze up) .
	Malfunction of Circulating System.	Refer to Troubleshooting "Circulating System" under No carbonated water at any of the dispensing valves .
CO ₂ gas is present at dispensing valves but no water.	No power to carbonator.	Verify toggle switch for Carbonator is in the ON position and Main Power Supply is ON .
	Water supply restricted to carbonator pump.	Verify water to unit by observing Filtered Water Pressure Gauge. It should register 55 psi (3.9 kg/cm ²). To adjust, loosen Locknut, turn Adjustment Screw clockwise to increase, counterclockwise to decrease. If regulator will not respond to adjustments, replace regulator. Examine Water Shut-off Valve(s) to Carbonator and ensure they are in the ON position.
	Water Filter restricted.	Place Filter By-pass Valve into the Filter By-pass position. Replace Cartridge Filter. Reposition valve handle to "operating" position.
	Water Inlet strainer clogged.	Remove Filter Screen from Inlet Strainer in carbonator Pump (Brass), flush with water to clean and reassemble.
	Liquid Level Control defective.	Push Toggle Switch for carbonator and circulator to the OFF position. Shut OFF Main Power Supply unit. Remove electrical Access Panel from unit. Locate liquid level control. Using a pair of insulated needle nose pliers, carefully remove the white wire from the terminal marked "H" and the black wire from the terminal marked "L" on the Liquid Level Control Board. Position safely to side. Turn ON Main Power Supply. Push carbonator Switch to the ON position. If carbonator pump and motor do not cycle ON immediately, that Liquid Level Control is defective. Replace.
	Electrode Assembly defective.	If Liquid Level Control is operating, test the Electrode Assembly, refer to Probable Cause "Liquid Level Control Defective". Verify wire leads are dry and that they are not touching. If not, replace Electrode.

Qualifier	Probable Cause	Corrective Action
<i>No carbonated water at any of the dispensing valves (continued)</i>		
CO ₂ gas is present at Dispensing Valves but no water. (continued)	Carbonator Pump worn (Brass pump).	Dispense Carbonated Water while listening for carbonator pump and motor to cycle ON at Refrigeration Unit. Pumps should operate between 6 to 12 seconds before cycling OFF . If operating time exceeds 30 seconds, carbonator Pumps is worn, replace Pump.
	Motor defective.	If Motor will not operate, verify voltage across Motor Terminals with voltmeter. If voltage reads 110 to 120 VAC, the Motor or Pump is defective. Loosen the Coupling Clamp with a flat-blade screwdriver and disengage Pump from Motor. If Motor still will not operate with Pump disengaged, Motor is defective. Replace.
	Carbonator Pump frozen.	Loosen the Coupling Clamp with a flat-blade screwdriver and disengage Pump from Motor. By hand, turn the Coupling Key in back of Pump. If pump shaft will not spin freely, Pump is defective and must be replaced.

Qualifier	Probable Cause	Corrective Action
<i>Carbonator pump and motor will not cycle OFF (possibly noisy pump)</i>		
Little or no carbonated water at dispensing valve.	Primary CO ₂ Regulator adjusted at extremely high pressure.	Verify CO ₂ Primary Regulators are set at 90 psi (6.3 kg/cm ²). Adjust if necessary. If regulator will not star in adjustment, replace regulator.
	Water supply to Carbonator Pump shut-off or restricted.	Verify water to unit by observing Filtered Water Pressure Gauge. It should register 55 psi (3.9 kg/cm ²). Examine Water Shut-off Valves to carbonator and ensure they are in the ON position. Examine Pump Strainer for restriction. Clean if necessary.
	Water Filter restricted.	Place Filter By-pass valve into the "Filter By-pass" position. If carbonator pump and motor immediately cycle OFF , Filter Cartridge is restricted. Replace Cartridge.
	Back Flow Preventer or Double Check Valve.	Examine Filter Water Pressure Gauge. If it registers 90 psi (6.3 kg/cm ²) CO ₂ gas is passing from the carbonator tank and through the Back Flow Preventer or Double Check Valve, preventing water from entering pump. Clean or replace Back Flow Preventer/Double Check Valve.
	Carbonator Pump worn.	Remove top cover from Remote Refrigeration Unit. Locate Toggle Relief Valve on Carbonator Tank and lift lever to allow CO ₂ gas to escape from Tank for 30 seconds. If during this time Carbonator Pump cycles OFF , pump is worn and should be replaced.
	Coupling Key defective.	Loosen the Coupling Clamp with a flat-blade screwdriver and disengage Pump from Motor. Examine Coupling Key in Pump. If defective, replace.

Qualifier	Probable Cause	Corrective Action
Carbonator pump and motor will not cycle OFF (possibly noisy pump) (continued)		
Carbonated water at dispensing valve.	Liquid Level Control defective.	Shut OFF main power supply to unit and push Toggle Switch for Carbonator and Circulator to the OFF position. Remove Electrical Access Panel from Refrigeration Unit and locate Liquid Level Control. Strip a 1-1/2" (3.8 cm) piece of solid strand wire of insulation to use as a jumper. Turn main power supply unit ON to unit. With a pair of insulated pliers, jump across Terminals marked "G, H and L" on Liquid Level Control. Simultaneously, while pushing corresponding Toggle Switch to "carbonator" to the ON position. If carbonator pump and motor continue to operate after Liquid Level Control Jumper Wire is in place, Liquid Level Control is defective, replace.
	Electrode defective.	Examine wire leads to ensure no breaks in connections. Remove and clean Electrode with fine sand paper and reinstall. <i>Note: Reversing Electrode Wire Leads on either electrode or Liquid Level Control will cause erratic operation of carbonator Motor. Refer to Wiring Diagram.</i>
Peculiar taste in carbonated water only.	Water filter contaminated.	Refer to Troubleshooting "Water Filter System" under Peculiar taste .
	Back Flow Preventer Valve leaking or Double Check Valve leaking.	Push Toggle Switch for carbonator to the OFF position. Turn Water Shut-off Valve to carbonator to the OFF position. Remove top cover from Remote Refrigeration Unit. Carefully disconnect water line on the outlet side of the carbonator pump. If water or CO ₂ is observed continually escaping from line, Back Flow Preventer/Double Check Valve is leaking. Disassemble, clean, and replace if necessary. <i>Caution: Carbonated water must never be allowed to flow through materials other than plastic or stainless steel. (Copper, zinc or galvanized material is non-acceptable.)</i>
	Carbonated water flowing through materials other than plastic or stainless.	Trace carbonated water flow through system. Ensure no foreign materials are present. Replace non-acceptable material if found.

Qualifier	Probable Cause	Corrective Action
<i>Carbonator pump and motor will not cycle OFF (possibly noisy pump) (continued)</i>		
Carbon particles in furnished drink.	Malfunction of Water Filter.	Refer to Troubleshooting "Water Filter System" under Carbon particles in finished drinks.
	Defective Carbonator Pump.	Remove top cover from Refrigeration Unit. Loosen Coupling Clamp with a flat-blade screwdriver and disengage pump from motor. Turn the Coupling Key by hand, in back of pump. If pump shaft does not turn freely and/or Carbon is found in pump, carbon veins are defective. Replace pump.
Carbonator Motor cycles ON and OFF in short cycles.	Defective Circulating Pump.	Refer to Troubleshooting "Circulating System" under Carbon particles in finished drinks.
	Electrode Assembly incorrectly wired or defective.	Examine wiring diagram found on Refrigeration Unit. Verify Electrode wiring leads are on proper terminals of both Electrode and Liquid Level Control. If problem still occurs, replace electrode.

Circulating System

Qualifier	Probable Cause	Corrective Action
<i>Warm drinks</i>		
Drinks warm throughout the day, warm all the time.	Malfunction of Refrigeration System.	Refer to Troubleshooting "Refrigeration System" under Warm drinks (carbonated water temperature over 40°F [5°C]) .
Drinks warm during periods of low demand, much colder during periods of high demand.	No power to Circulating Motor.	Verify Switch to Circulating Motor is in the ON position and Main Power Supply is ON .
Carbon Particles in finished drink.	Motor defective.	Using a flat-blade screwdriver, loosen the Coupling Clamp and disengage Pump from Motor. If Motor will not operate, verify voltage across Motor Terminal with voltmeter. If voltage reads from 110 to 120 VAC, the Motor is defective and should be replaced.
	Circulating Pump defective (stainless steel).	Dispense approximately 1 gallon of carbonated water at dispensing valves. If temperature of carbonated water drops, Circulating pump is not operating. Examine Coupling Key found between Pump and Motor Shaft. If coupling key is defective, replace. If key is operational, Circulating pump is defective, replace.
No CO ₂ gas or water present at dispensing valve.	Malfunction of Water Filter.	Refer to Troubleshooting "Water Filter System" under Carbon particles in finished drinks .
	Malfunction of Carbonated Water System.	Refer to Troubleshooting "Carbonated Water System" under Carbon particles in finished drinks .
	Circulating Pump defective (Stainless Steel).	Remove top cover from Refrigeration Unit. Loosen Coupling Clamp with a flat-blade screwdriver and disengage Pump from Motor. Turn Pump shaft with screwdriver. If Pump does not turn freely and/or carbon is found in Pump, carbon veins in pump are defective. Replace Circulating Pump.
CO ₂ gas is present at dispensing valves but no carbonated water.	Malfunction of Refrigeration System.	Refer to Troubleshooting "Refrigeration System" under No carbonated water at dispensing valve (freeze up) .
	Particles obstructing flow through Circulating Circuit (In-line Strainer).	Remove top cover from Remote Refrigeration. Push toggle switch to carbonator and circulator to the OFF position. Lift lever on Toggle Relief valve at top of carbonator Tank until pressure is completely released. Remove In-line Strainer Screen. Flush with clean water and reassemble.
	Malfunction of Carbonating System.	If CO ₂ gas is present at the Dispensing Valves and there is no water, the problem is in the Carbonated Water System. Refer to Troubleshooting "Carbonated Water System".

Compressed Air System

Until repairs can be made on Compressed Air System, place Air/CO₂ Change-over Valve in the CO₂ Operating position.

Qualifier	Probable Cause	Corrective Action
No syrup		
Air Compressor will not cycle ON and Air Pressure Gauge registers 0 psi.	No power to Air Compressor.	Verify Toggle Switch to Air Compressor is in the ON position and main power supply is ON .
	Pressure Switch defective.	Remove Pressure Switch Cover and use a voltmeter across Switch to determine whether "open" or "closed". If in "open" position, replace switch.
	Motor defective.	Verify voltage across Motor with a voltmeter, if Motor/Pump assembly will not operate, it is defective and should be replaced.
	Pump frozen.	Same as above for Motor defective.
Air Compressor cycles ON and OFF and Air Pressure Gauge readings range between 70 psi (4.9 kg/cm ²) to 90 psi (6.3 kg/cm ²).	Air/CO ₂ Change-over Valve placed in incorrect position.	Place Air/CO ₂ Change-over Valve to the Air or CO ₂ "operating" position. Note: <i>If lever is positioned between Air and CO₂ the gas supply is shut OFF to syrup system.</i>
	Malfunction of Syrup System.	Refer to Troubleshooting "Syrup System", under No syrup .
	Malfunction of Refrigeration System.	Refer to Troubleshooting "Refrigeration System", under No carbonated water at dispensing valves (freeze up) .

Qualifier	Probable Cause	Corrective Action
No syrup (continued)		
Air Compressor operates excessively.	Leak at Shake Machine, Orange Juice Dispenser or other optional equipment.	Turn air supply to Shake Machine to OFF position. If Air Compressor cuts out and maintains pressure, leak is at Shake Machine or Orange Juice Dispenser. Refer to manufacturer's manual for Troubleshooting.
	Leak at Compressed Air System.	Use a soap solution around all connections starting from the Air Motor/Pump assembly to the Low and Medium Pressure Syrup Regulators. If bubbles appear, tighten loose connections carefully.
	Automatic Drain or Petcock leaking.	Place drain line for bottom of Automatic Drain or Petcock in cup of water. If air bubbles appear, Automatic Drain or Petcock is leaking. Clean and/or replace as necessary.
	Air leak in syrup system.	Refer to Troubleshooting "Syrup System" under No syrup, air leak at syrup system .
	Restricted Germicidal Filter on Air Compressor.	Replace Germicidal Filter. Note: <i>This Filter is not designed to be cleaned, but must be replaced when exhausted.</i>
	Water in Air Accumulator Tank.	Verify Automatic Drain is operating. If inoperative or defective, replace. If unit is not equipped with Automatic Drain use Petcock to remove water from tank.
	Motor/Pump Assembly inoperative.	If Motor/Pump assembly operate without building up to 90 psi (6.3 kg/cm ²) as needed to cycle OFF . Pump Assembly is defective and must be replaced.
	Pressure Switch improperly adjusted or defective.	Observe Air Pressure Gauge to ensure proper cycle ON at 70 psi (4.9 kg/cm ²) and cycle off at 90 psi (6.3 kg/cm ²) settings. Refer to instructions found under Switch cover for adjusting. If Switch will not respond to adjustment, replace switch.
	Check valve defective.	While Air Compressor is in the OFF cycle, use a soap solution around Head Gasket on Motor/Pump Assembly. If bubbles appear, replace Check valve located on the Air Accumulator Tank.
Peculiar taste in finished product.	Contaminated Germicidal Filter on Air Compressor.	Replace Germicidal Filter. Note: <i>This filter is not designed to be cleaned, but must be replaced when exhausted.</i>
	Water in Air Accumulator Tank.	Drain trapped water from tank by removing Drain Line from top of Automatic Drain. Disassemble and clean Automatic Drain. If unit is not equipped with automatic drain, use petcock to remove water from tank.
	Water Filter contaminated.	Refer to Troubleshooting "Water Filter System" under Peculiar taste .

Dispensing Valve and Tower

Qualifier	Probable Cause	Corrective Action
All corresponding valves dispensing no syrup.	Malfunction of syrup system.	Refer to Troubleshooting "Syrup System" under No syrup or insufficient syrup in finished drink.
No syrup at only one dispensing valve.	Syrup Shut-off Valve closed or partially closed.	Remove top cover from Dispensing valve or Tower. Locate Syrup Shut-off Valve on right hand side of Dispensing valve. Verify shut-off is turned fully open.
	Mounting Block restricted.	Remove Dispensing valve from Mounting Block. Place cup over Syrup outlet on Mounting Block and carefully open Syrup Shut-off Valve. If little or no syrup is present, Mounting Block is restricted. Remove and clean mounting block. Replace if necessary.
<i>No syrup or insufficient syrup in finished drink</i>		
No carbonated water at half or all dispensing valves.	Flow Control our of adjustment or inoperative.	Readjust Flow Control to proper Brix. If no response, clean Syrup Flow Control. Replace if necessary.
	Valve Port restricted.	Clean Syrup valve Port Assembly.
	Seat swollen.	Replace Syrup Seat.
	Solenoid Coil defective.	Replace Syrup Solenoid Coil.
	Malfunction of Carbonated Water System.	Refer to Troubleshooting "Carbonated Water System" under No carbonated water at any of the dispensing valves.

Qualifier	Probable Cause	Corrective Action
<i>No carbonated water or insufficient carbonated water in finished drink</i>		
No Carbonated Water only at one dispensing valve.	Carbonated water Shut-off Valve closed or partially closed.	Remove top cover from Dispensing valve or Tower. Locate Carbonated Water Shut-off Valve on left hand side of Dispensing valve. Verify Shut-off Valve is turned fully open.
	Mounting Block restricted.	Remove Dispensing valve from Mounting Block. Place cup over Carbonated Water outlet on Mounting Block and carefully open Carbonated Water Shut-off Valve. If little or no Carbonated Water is present, Mounting Block is restricted. Remove and clean mounting block. Replace if necessary.
	Flow Control our of adjustment or inoperative.	Readjust Flow Control to proper Brix (5 oz in 4 seconds Standard valve, 10 oz in 4 seconds Fast Flow valve). If no response, clean Carbonated Water Flow Control. Replace if necessary.
	Valve Port restricted.	Clean Carbonated Water valve Port Assembly.
	Seat swollen.	Replace Carbonated Water Seat.
	Solenoid Coil defective.	Replace Carbonated Water Solenoid Coil.
	Carbonated Water Switch defective (black).	Replaced Carbonated Water Switch.

Qualifier	Probable Cause	Corrective Action
<i>No water or insufficient water in finished drinks</i>		
All valves dispensing noncarbonated drinks no water.	Water Shut-off Valve closed or partially closed.	Refer to Troubleshooting "Water Booster System" under Low or No Water Pressure at Noncarbonated Beverages .
Problem occurs at only one dispensing valve.		Refer to this section on No carbonated water at only one dispensing valve in the dispensing valve .
Too much Syrup, Carbonated Water or Water in finished drink. Problem occurs at only one dispensing valve.	Syrup, carbonated water, or noncarbonated water flow control out of adjustment or inoperative.	Readjust appropriate Flow Control. If Flow Control does not respond to adjustment, clean Flow Control. Replace if necessary. Carbonated Water Flow rates: (5 oz in 4 seconds Standard valve, 10 oz in 4 seconds Fast Flow valve).
Too much syrup in finished drink. All valves dispensing same flavor-too much syrup.	Malfunction of syrup system.	Refer to Troubleshooting "Syrup System" under Drinks too sweet .
Too much water in finished drink. All valves dispensing noncarbonated drink too much water.	Malfunction of water Booster system.	Refer to Troubleshooting "Water Booster System" under Qualifier: Pump and motor cycles ON and OFF excessively .
Syrup or Carbonated Water or Water dripping from Nozzle.	Valve port scarred.	Disassemble appropriate Syrup or Water Assembly. Examine valve Port for scars or nicks. Replace if necessary.
	Armature Spring or Retaining Ring broken.	Disassemble appropriate Syrup or Water Assembly. Examine Armature, Spring and Retainer Ring. If damaged, replace.
	Seat scarred or obstructed.	Disassemble appropriate Syrup or Water Assembly. Examine Seat, if scarred, replace. If foreign material is found in Assembly, remove, reassemble.
Valves will not activate when Selection Panel pressed. Problem occurs at two (2) or three (3) consecutive Valves on one (1) tower.	Transformer inoperative.	Verify wire leads from Transformer have solid connections. Switch low voltage lead from Transformer supplying power to left and right hand side of Tower. If Valves operate and the other three do not, Transformer is defective. Replace.
	Dispensing tower's ON and OFF Toggle defective.	If after switching Leads, the three valves still do not operate, the ON and OFF Toggle Switch is defective.

Qualifier	Probable Cause	Corrective Action
<i>No water or insufficient water in finished drinks (continued)</i>		
Problem occurs at all valves on one (1) dispensing tower.	No power to transformer or transformer defective.	Verify power with a voltmeter at wall outlet. Verify power across low voltage leads on transformer. If 24 volts are present ON and OFF Toggle Switch is defective. Replace.
Problem occurs at only one (1) dispensing valve.	Dispensing tower's ON and OFF is Switch defective.	Verify Main Power Supply and power at Transformer Leads replace ON and OFF Switch if operative.
	Poor connection on valve Wire Harness.	Trace wiring on defective valve and reconnect any loose wires. Clean and reconnect any corroded connections.
	Portion Control Timer inoperative.	Replace the problem valve Portion Control Timer with a known Operative Timer. If valve then operates, Portion Control Timer was defective. Replace.
	Selection Switch inoperative.	Replace defective Portion Control Timer with operative Timer. If Valves still will not activate, Selection Panel is defective. Replace Selection Switch.
	Poor connection at Contact Clips on Selection Panel (with Portion Control Timer).	Examine Contact Clips on Selection Panel and ensure proper contact between Portion Control Timer and Contact Clips.
Valve will not shut OFF .	Moisture on Portion Control Timer or Contact Clips.	Remove top cover from Dispensing Tower. Remove all moisture from Portion Control Timer and Contacts.
	Portion Control Timer Adjustment Screw turned beyond control limit.	Turn Portion Control Adjustment Screws on defective valve counterclockwise 10 complete turns. If valve shuts off when selection is pressed, readjust for proper portions. Note: Several revolutions may be necessary to bring control back into range.
	Portion Control Timer defective.	Verify above probables are not the problem. Push ON/OFF Switch for Dispensing Tower to the OFF position. If valve ceases to dispense when pushed to ON position, Portion Control Timer is defective. Replace.
	Selection Panel defective.	Push ON/OF Switch for dispensing tower to the OFF position. If valve ceases and then continues to dispense when switch is pushed in ON position, Selection Panel is defective. Replace.

Qualifier	Probable Cause	Corrective Action
No water or insufficient water in finished drinks (continued)		
Foaming of finished products.	Nozzles, Syrup Tube Diffusers dirty.	Remove and clean Nozzle Assemblies and reassemble.
	Warm drinks.	Refer to Troubleshooting "Refrigeration System" under Warm drinks .
	Incorrect pressure on syrup.	Verify pressure supplied to sugar base products is at 60 psi (4.2 kg/cm ²). Adjust Medium Pressure Regulator if necessary. Verify pressure supplied to diet product is at 15 psi (1.1 kg/cm ²). Adjust Low Pressure Regulator if necessary. Note: Ensure the Low Pressure Supply Line has not mistakenly been switched for a Medium Pressure Supply Line on the diet tank.
	Change-over Valve Medium or Low Pressure is in the wrong position.	Verify valve Medium to Low Pressure is in the Low Pressure position for diet products.
	Air or CO ₂ gas in syrup line.	Replace empty Syrup Tank. Dispense Syrup from valve until consistent flow is achieved and product stabilizes. If evidence of air is still entering line, replace Liquid Disconnect which is allowing air to be drawn into syrup supply.
	Flake ice.	Only cube ice should be used for carbonated beverages.
	Improper adjustment of valve.	Ensure carbonated water flow is properly set (5 oz. in 4 seconds standard valve, 10 oz in 4 seconds Fast Flow valve). Ensure Brix is properly set. Adjust as necessary.
Unit totally inoperative; all electrical switches in the ON position.	Power failure, all power to system is OFF , or Fuse/Circuit Breaker is "open".	Check Circuit Breaker. Reset. Examine Time Delay, replace if necessary.

Electrical System

Qualifier	Probable Cause	Corrective Action
Fuse/Circuit Breaker is open.	Short Circuit or overload within unit.	<p>Push Toggle Switches labeled carbonator and circulator to the OFF position. Push the Toggle Switches for Booster Pump, Air Compressor, Agitator and Refrigeration to the OFF position. Replace fuse(s) and reset circuit breaker. Push the Toggle Switches ON in the following sequence as labeled below, to locate short or overload within unit, waiting momentarily between steps. *Agitator *Refrigeration *Carbonator A and/or B *Circulator A and/or B (after carbonator Motor Cycles OFF) *Booster Pump *Air Compressor.</p> <p>Push the Agitator Toggle Switch in the ON position. If the fuse/circuit breaker opens, the trouble is in the Agitator Motor Circuit. This Circuit must be checked for shorts and/or overload. If the fuse/circuit breaker does not open after running about 1 minute, the problem is not in the Agitator Motor Circuit.</p> <p>Push the Refrigeration Toggle Switch in the ON position. If the fuses/circuit breaker opens, the trouble is in the Refrigeration Circuit. Refer to wiring diagram for possible faulty components. Push the carbonator Toggle Switch A to the ON position. Draw Carbonated Water from the Dispensing valve until Pump cycles. If the fuse/circuit breaker opens, the trouble is in the carbonator Circuit. Refer to wiring diagram for possible faulty components.</p> <p>Push the carbonator Toggle Switch B to the ON position. Follow procedure above for carbonator A. Push the Circulator Toggle Switch A to the ON position. If fuse/circuit breaker opens, the trouble is in the Circulator Circuit. Refer to wiring diagram for possible faulty components. Push the Circulator Toggle Switch B to the ON position. Follow procedure above for Circulator A.</p> <p>Push the Booster Pump Toggle Switch to the ON position (allow unit to cycle). If fuse/circuit breaker opens, the trouble is in the Booster Pump Circuit. Refer to wiring diagram for possible faulty components.</p> <p>Push the Air Compressor Toggle Switch to the ON position. (Allow unit to cycle). If fuse/circuit breaker opens, the trouble is in the Air Compressor Circuit. Refer to wiring diagram for possible faulty components.</p> <p>Important Note: Worn out Circuit Breakers or low voltage are frequently responsible for shorts and overloads. Contact service agent to examine possible defective Circuit Breakers or low voltage.</p>

Refrigeration System

Until repairs can be made on unit with no Ice Bank, push Refrigeration and Agitator Switch to the **OFF** position and ice down Bath using ice from Ice Maker.

Qualifier	Probable Cause	Corrective Action
Warm drinks (carbonated water temperature over 40°F [5°C])		
Compressor operates but no ice present at water bath.	Water Bath Feeder Valve inoperative (not enough water in bath).	Remove tope cover from Remote Refrigeration Unit. Verify if water level is considerably below Stand Pipe. If so, Water Make-Up valve is inoperative. Remove, disassemble and clean out valve. Replace, refill Bath and allow carbonator to cycle while inspecting valve to ensure proper operation. Replace if necessary.
	Water leak inside bath.	Remove top cover from Remote Refrigeration Unit. Inspect Water Bath at Stand Pipe. If considerable water is observed running over and out the drain, there is a water leak inside Bath. The leak causes the Ice Bank to melt as fast as it's formed. Drain Bath to located the leak, repair and refill bath.
	Fan or Motor inoperative (air cooled units).	Examine Fan and Motor on Air Cooled Units at Condenser. If either are found to be inoperative while compressor is running, replace inoperative fan or motor. Caution: <i>Inoperative Fan and Motor can cause short cycling of compressor.</i>
Compressor operates but no ice present at water bath.	Condenser restricted.	For Air Cooled Units, clean the Condenser removing all dust and lint. On Water Cooled Units: Using a thermometer verify temperature at water discharge line. If operating outside of the 95°F (35°C) to 105°F (41°C) range, adjust Water Modulating valve, replace. Caution: <i>Restricted Condenser can cause short cycling of compressor.</i>
	Excessively warm room.	Verify the Refrigeration Unit is operating in a well ventilated area and that there are no obstructions blocking Condenser. If so, remove obstructions if inoperative.
	Lack of Refrigerant Charge.	Examine Sight Glass. If bubbles appear while compressor is operating system is low on charge. Refer to Serial Plate for proper refrigeration charge.
	Defective Expansion valve.	If no bubbles appear in Sight Glass then examine suction line, frost on the suction line is a sign of defective Expansion valve. Replace if inoperative.

Qualifier	Probable Cause	Corrective Action
Warm drinks (carbonated water temperature over 40°F [5°C]) (continued)		
Compressor operates with Ice present at water bath.	Defective Agitator Motor Assembly.	Remove top cover from Remote Refrigeration Unit. Examine the Agitator Motor Assembly, ensure propeller is secured to Agitator and that the Agitator Switch is in the ON position, allowing the water in Bath to be agitated across the cooling coils. If Motor or Propeller is inoperative, replace.
	Malfunctioning of Circulating System.	If ice is present on Evaporator Coil and Agitator Motor Assembly is operating the Refrigeration System is functioning. However, the Circulating System may not be functioning. Refer to Troubleshooting "Circulating System". Caution: Always make certain that proper line voltage is present.
Compressor won't operate and no ice at water bath.	Defective Switch.	Check to ensure Refrigeration Switch is in the ON position.
	Fuse/Circuit Breaker open.	Locate Circuit Breaker box and identify proper breaker for Remote Refrigeration Unit. Ensure it is in the ON position by switching OFF and then ON again. If breaker will not reset, refer to Troubleshooting "Electrical System".
	Time Delay Fuse burned out.	Inspect Time Delay Fuses at the wall quick shut-off panel. One of the fuses may be burned out causing half the unit to shut down. If this is suspected replace all of the fuses.
	Defective High Pressure Control.	Examine High Pressure Control to ensure wire leads are securely attached to terminals. If trouble is suspected with control, replace.
	Defective Ice Bank Control.	Remove Electrical Access Panel and using a voltmeter across the Ice Bank Control, verify control is in the "closed" position. If control is found to be in the "open" position, that Control should be replaced.
	Defective Contactor.	Remove Electrical Access Panel. Use a voltmeter across Contactor Coil. If current exists across Coil, and Contactor remains "open", Contactor is defective. Replace.
	Defective Relay or Defective Capacitor or Defective Overload.	Examine Relay/Capacitor/Overload to ensure wire leads are securely attached to terminals. Replace any faulty components.
	Defective compressor.	If after checking each of the above items, you still experience problems, test compressor for possible defects or grounding.

Qualifier	Probable Cause	Corrective Action
<i>No carbonated water at any of the dispensing valves</i>		
CO ₂ gas is present at dispensing valves but no Carbonated Water.	Malfunctioning of Carbonating System.	If CO ₂ gas is present at the Dispensing Valves and there is no water, the problem is in the Carbonated Water System. Refer to Troubleshooting "Carbonated Water System".
No CO ₂ Gas or water present at dispensing valve.		In a "freeze up" situation, push Refrigeration and Agitator Toggle Switches to the OFF position. Drain water from Bath. Pour lukewarm (never hot) water over the Product Coils until thawed. Ice down Water Bath using ice from Ice Maker until further repairs can be made.
	Defective Agitator.	Examine the Agitator Motor Assembly. Ensure Propeller is operating and secured to Agitator and that the Agitator Toggle Switch is in the ON position. If Motor is inoperative, replace.
	Defective Ice Bank Control.	Remove Electrical Access Panel. Use a voltmeter across the Ice Bank Control. Verify Control is in the "open" position. If Control is stuck in the "closed" position, the unit will "freeze up". Replace Control if necessary. If unit builds and Ice Bank to the point of extending into stainless steel coils, the Ice Bank Control must be replaced.
On units equipped with the "Red" Refrigeration Warning Light.	Defective Contactor.	Use a voltmeter across Contactor Coil. If no current is present across Coil, but Contactor remains "closed", Contactor is defective. Replace defective Contactor.
	Defective Primary Ice Bank Control.	When the Refrigeration Warning Light illuminates, the Primary Ice Bank Control is defective and should be replaced. The Secondary Control operates the Compressor until the Primary Control is replaced.
Refrigeration Warning Light cycles ON and OFF with Compressor.		Note: When the Refrigeration Compressor cycles ON , Warning Light will turn OFF . When the Compressor cycles OFF the light will illuminate.

Syrup System

Qualifier	Probable Cause	Corrective Action
No syrup or insufficient syrup in finished drink.	Syrup Tank is empty.	Replace Syrup tank and purge air out of Dispensing Valves affected, until steady syrup supply is dispensed.
	Kinked Syrup lines.	Examine all exposed Syrup Lines and relieve any sharp bends or kinks. Note: <i>Observe all independent lines from Syrup Tank to Filters for kinks or bends. Correct as needed.</i>
	Low Pressure Regulator inoperative.	Low Pressure Regulator controls the pressure to diet beverages. Verify pressure is set at 15 psi (1.1 kg/cm ²). To increase, adjust clockwise, to decrease, adjust counterclockwise. If regulator does not respond, repair or replace regulator.
	Medium Pressure Regulator inoperative.	Medium Regulator controls the pressure applied to the sugar based beverages. Verify pressure is set at 60 psi (4.2 kg/cm ²). To increase, adjust clockwise. To decrease, adjust counterclockwise. If regulator does not respond, repair or replace regulator.
	Check Relief valve restricted.	Disengage Gas Quick Disconnect on suspected restricted flavor at Syrup Tank. Depress Poppet valve on bottom side of Gas Disconnect. If a low or poor pressure supply is apparent, replace Check Relief valve.
	Gas/Syrup Tank Plug Valves inoperative.	Replace Syrup Tank. If this solves the problem, tag defective tank so bottler can make necessary repairs. (It is extremely rare to have inoperative Tank Plug Valves.)
	Quick Disconnects (Gas or Syrup) not fully engaged on Syrup Tank.	Disengage Quick Disconnects on one Tank at a time. Rinse and clean with warm water. Lubricate the O-ring on the Syrup Tank Plug with water. Reattach the Quick Disconnects to the appropriate Syrup Tank Plug. Gas Quick Disconnects are gray or have two key slots. Syrup Quick Disconnects are black or have three key slots.
	Quick Disconnect Valves or Tank Jumper inoperative.	Gas Quick Disconnects: Open the Relief valve on the top of the syrup tank lid. If the Gas Quick Disconnect is opening properly, pressure should continue to bleed from the Gas Relief valve. If not, replace Gas Quick Disconnect. Syrup Quick Disconnects: Open the Dispensing valve (Syrup Side only) for appropriate flavor. Dispensing syrup for at least 10 seconds. If CO ₂ /Air pockets appear in syrup, replace Syrup Quick Disconnect. If syrup flow is inadequate or fluctuates during 10 seconds of flow, replace Syrup Quick Disconnects.

Qualifier	Probable Cause	Corrective Action
No syrup of insufficient Syrup in finished drink. (continued)	Gas leak at Syrup System.	Use a soap solution around all connections, starting from the Low and Medium Pressure Regulators to the base of the Syrup Tank Plugs, observe Quick Disconnects, Tank Cap and Gasket, Tank Plugs and Syrup Tank O-rings for leaks. Repair and replace if necessary.
	Syrup Filter restricted.	Disengage Syrup Quick Disconnect from the appropriate Syrup Tank. Relieve pressure at the corresponding Dispensing valve. Remove the Screw clamp and the Filter Screen. Wash the Filter Screen with warm water and reassemble.
	Frozen Syrup Coil.	Refer to Troubleshooting "Refrigeration System" under No carbonated water at any of the dispensing valves (Freeze up).
	Dispensing valve inoperative.	Refer to Troubleshooting "Dispensing Valve and Tower" under No syrup or insufficient syrup.
Drinks too sweet.	Low Pressure Regulator inoperative.	Verify Low Pressure Regulator set at 15 psi (1.1 kg/cm ²). Adjust Regulator if necessary. If Regulator will not respond, repair or replace Regulator.
	Medium Pressure Regulator inoperative.	Verify Medium Pressure Regulator set at 60 psi (4.2 kg/cm ²). Adjust Regulator if necessary. If Regulator will not respond, repair or replace Regulator.
	Dispensing valve inoperative.	Refer to Troubleshooting "Dispensing Valve and Tower" under Too much syrup in finished drink.
Peculiar taste.	Contaminated Syrup.	Replace tank and sanitize the system.

Water Booster System

Qualifier	Probable Cause	Corrective Action
Low or no water pressure at noncarbonated beverages		
Water Booster will not cycle ON . Both the pressurized filter water and filtered water pressure register 55 psi (3.8 bar).	No power to Water Booster Pump.	Verify Toggle Switch for "Booster Pump" is in the ON position and main power supply is ON .
	Pressure Switch defective.	Remove Pressure Switch Cover and use a voltmeter across terminals to determine whether "open" or "closed". If in the "open" position, replace Switch.
	Motor defective.	If Motor will not operate, verify voltage across Motor Terminals with a voltmeter. If voltage reads from 110 to 120 VAC, the Motor is defective and should be replaced.
	Pump frozen.	Loosen the Coupling Clamp with a flat-blade screwdriver and disengage pump from Motor. Turn the Coupling key by hand, in back of pump. If pump shaft will not spin freely, Pump is defective and must be replaced.
Water Booster cycles ON and OFF and pressurized Filtered Water Gauged readings range between 65 psi (4.6 kg/cm ²) to 85 psi (6.0 kg/cm ²).	Water supply shut-off after Booster System.	Examine Shut-off Valve to "Plain Water to Unit" and "Water to Coffee Machine" and ensure both are in the ON position.
	Frozen Water Coil.	Refer to Troubleshooting "Refrigeration System" under No carbonated water at any of the dispensing valves (freeze up) .
Pump and Motor will not cycle OFF .	Water supply to Booster Pump shut OFF .	Examine the Shut-off Valve to Booster Pump and ensure valve is in the ON position.
	Restricted Water Filter.	Observe Filter Water Pressure Gauge. If pressure drops total of 40 psi (2.8 bar) or more when pump cycles ON . Replace filter.
	Leak on Booster System Pump Strainer obstructed.	Locate water leaks on system and repair. Remove Pump Strainer at Brass Booster Pump, flush screen with water to clean. Reassemble and position in place. Replace screen if necessary.
	Pump Coupling Key defective.	Using a flat-blade screwdriver, loosen Coupling Clamp and disengage Pump from Motor. Examine Coupling Key, if rounded off on either end, replace.
	Pump defective.	Examine Pressurized Filter Water Pressure Gauge. If Pump and Motor continue to operate but fail to build up to 85 psi (6.0 kg/cm ²) in order to cut off, pump is defective. Replace Pump.
	Pressure Switch improperly adjusted or defective.	Observe Pressurized Filtered Water Pressure Gauge to ensure proper cycle ON at 65 psi (4.6 kg/cm ²) and cycle OFF at 85 psi (6.0 kg/cm ²). Refer to instructions found under Switch Cover for adjusting. If Switch does not respond to adjustment, replace switch.

Qualifier	Probable Cause	Corrective Action
Low or no water pressure at noncarbonated beverages (continued)		
Pump and Motor cycles ON and OFF excessively.	Leak on Booster System.	Locate water leaks on system and repair.
	Check valve defective.	Observe Filtered Water Pressure Gauge. If pressure rises and drops with Pressurized Filtered Water Gauge, the Water Inlet Check valve on Pump is defective. Replace Check valve.
	Pressure Switch improperly adjusted or defective.	Observe Pressurized Filtered Water Pressure Gauge to ensure proper cycle ON at 65 psi (4.6 kg/cm ²) and cycle OFF at 85 psi (6.0 kg/cm ²). Refer to instructions found under Switch Cover for adjusting. If Switch will not respond to adjustment, replace switch.
	Accumulator Tank pressure set improperly.	Push Toggle Switch and Water Shut-off Valve to Booster Pump to the OFF position. Activate Plain Water button until water flow ceases. Using a tire gauge verify a 60 psi (4.2 kg/cm ²) charge on Tank. Recharge if necessary. Note: When charging Accumulator Tank, only AIR should be used.
	Accumulator Tank bladder ruptured.	Repeat procedures above. If water is found inside Air Chamber when verifying pressure charge, bladder is ruptured. Replace Accumulator Tank.
	Motor overheating.	Using a flat-blade screwdriver, loosen Coupling Clamp and disengage Pump from Motor. Turn Coupling Key by hand, in back of Pump. If Coupling Key is difficult to turn, it may cause defective Motor to overheat. Replace Motor if necessary.
Peculiar taste in Non-carbonated beverages.	Water Filter contaminated.	Replace Filter. Refer to Troubleshooting "Water Filter System" under Peculiar taste .
	Accumulator Tank bladder ruptured.	Replace Accumulator Tank. Refer to "Pump and Motor Cycle ON and OFF excessively" Accumulator Tank bladder ruptured.
	Malfunction of Carbonated Water System.	Refer to Troubleshooting "Carbonated Water System" under Peculiar taste , Probable Cause: Back Flow Preventer leaking.

Water Filter System

Until repairs can be made on the Water Filter, place valve handle into “filter By-pass” position.

Qualifier	Probable Cause	Corrective Action
Carbon particles in finished drink.	Water By-pass valve is not in the “filtering” position.	Verify By-pass valve handle is in the Filter “operating” position. If particles continue to appear, filter must be serviced.
	Defective or damaged seal on Filter Cartridge.	Verify O-rings are not twisted or nicked. Verify Cartridge is solid and free of cracks. Replace if necessary.
	Filter Cartridge installed without Inlet Seal.	Remove Cartridge from Canister. Clean Canister Lid and Shell assembly. Replace with new Filter Cartridge, making sure to remove Water Inlet Seal.
	Defective carbonator Pump.	Refer to Troubleshooting “Carbonated Water System”.
	Defective Circulating Pump.	Refer to Troubleshooting “Circulating System”.
Carbonator and Water Booster Pump extremely noisy.	Restricted Water Filter.	Observe Filter Water Pressure Gauge. If pressure drops at total of 40 psi (2.8 bar) or more when pump cycles ON , replace filter.
	Filter Cartridge installed without removing Water Inlet Seal.	Removed Cartridge from Canister. Clean Canister Lid and Shell Assembly. Install new Filter Cartridge, making sure to remove Cartridge Inlet Seal.
	Water supply to Filer restricted.	Verify water supply is turned ON to unit. Refer to Troubleshooting “Carbonated Water System” and “Water Booster System” for additional solutions.
Peculiar taste.	Water Filter contaminated.	Place Filter valve into “Filter By-pass” position. Replace Filter and reposition valve handle to “filter operating” position.

When the Brix is OFF

Air Compressor

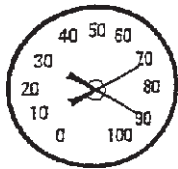
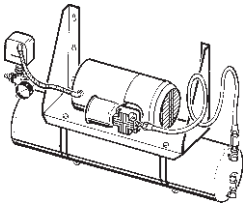

70 psi (4.8 bar) ON
90 psi (6.2 bar) OFF

Filtered Water Pressure

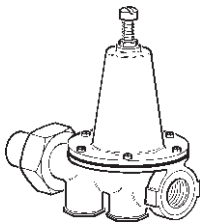

Service
Filters

Maximum Efficiency
55 psi (3.8 bar)

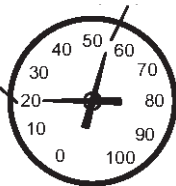

CO₂ High Pressure

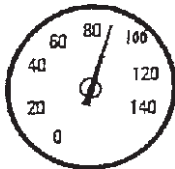
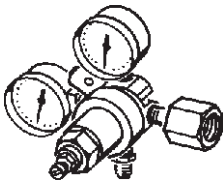

90 psi (6.2 bar)

Drink Temperature

Below 39°F (3.9°C)

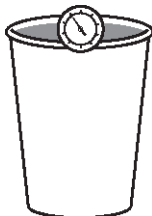

Bag-In-Box Usage

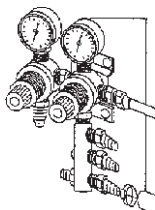

Medium Syrup Pressure

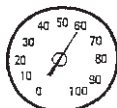

60 psi (4.1 bar)

Syrup Tank Usage

Low Syrup Pressure



15 psi (1.0 bar)

Medium Syrup Pressure

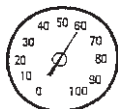

60 psi (4.1 bar)

Pressurized Filtered Water Pressure (Water Booster)

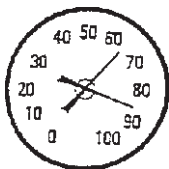
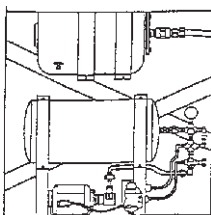

65 psi (4.5 bar) ON
85 psi (5.9 bar) OFF

Problem	Probable Cause	Solution
Drink too warm.	Refrigeration switch OFF .	Turn ON refrigeration switch.
	Condenser dirty.	Have condenser cleaned.
	Condenser obstructed.	Remove any objects blocking the air flow in or out of the unit.
	Circulator switch OFF .	Turn ON circulator switch and allow time for drinks to cool.
		<p>Note: <i>If service is required, you can continue to dispense cold drinks by completing following this procedure.</i></p> <ol style="list-style-type: none"> 1. Turn OFF the compressor switch and agitator switch. 2. Drain the water from the water bath. Reinstall the grey plastic over-flow pipe. 3. Fill water bath with ice from the ice machine. 4. Monitor frequently. Refill as needed.
Not enough carbonation.	CO ₂ Shut-off Valve OFF .	Open Shut-off Valve.
	CO ₂ cylinder empty.	Switch over to a new cylinder and dispense carbonated water until carbonation returns.
Product foaming.	Dirty or sanitizer soaked.	Clean or replace nozzles.
	Warm drinks.	See "Drink too warm" under Problem above.
No syrup dispensed.	Empty syrup container.	Replace syrup container.
	Air Compressor is OFF .	Turn ON and plug-in the Air Compressor.
	Change-over valve centered.	Position switch totally on either air or CO ₂ .
No carbonated water dispensed.	Carbonator turned OFF .	Turn ON carbonator switch.
	Water supply turned OFF .	Turn ON water to the system.
Product has an off taste.	Dirty nozzles.	Clean or replace nozzles.
	Out of date syrup.	Replace with fresh syrup.
	Saturated water filters.	Replace water filters.

Component Check Procedures

Test Procedures: MPC 64A Timer/ Selection Pad

MPC 64 A Timers can be placed in the test mode as follows:

1. Flip power switch off.
2. While depressing "CAL" button on selection pad, flip power switch back on.
3. Release "CAL" button when red LED comes on.

Faucets will energize for 2 seconds, each in sequence, starting with faucet #1 (far left).

Timer is now in the Test Mode. To stop faucets use one of two procedures:

- A. Turn power switch off. This will save the programmed times, Use this procedure for testing or sanitizing.
- B. Push "CAL" button. All programmed times for all stations will go to factory default times.
Default times are:
Size #1 1 - 1.5 seconds
Size #2 4 - 4.5 seconds
Size #3 6 - 6.5 seconds
Size #4 8 - 8.5 seconds

PIN IDENTIFICATION

J-7 = Valve 1 **J-10** = Valve 4

J-8 = Valve 2 **J-11** = Valve 5

J-9 = Valve 3 **J-12** = Valve 6

Check for 24 Volts at each solenoid cable connector, **J-7** through **J-12**, with cables removed.

With cables on, check for 24 VAC across solenoids at dispensing valve while dispensing respective valve.

J-15 Power to Valves 1,2,3.

J-20 Power to Valves 4,5,6 and microprocessor.

Loss of power at **J-15** results on loss of power to valves 1,2,3.

Loss of power at **J-20** results on loss of power to microprocessor — no valves will work.

J-16 Station & Sizes

Revision May 28, 2003

- #1 Stop/Fill
- #2 Large
- #3 Medium
- #4 Small
- #5 Valve 6 (or nothing on a 5 Valve tower)
- #6 Valve 5
- #7 Valve 4
- #8 Valve 3
- #9 Valve 2
- #10 Valve 1
- #11 Blank
- #12 Extra Large

Use a jumper wire to make these connections to determine if timer is functioning properly.

- A. Jump pin 1 to pin 5,6,7,8,9,10. Appropriate Valve should energize as long as pins are jumped.
- B. Jump pin 12 to pin 5,6,7,8,9,10. Valves should pour EXTRA LARGE.
- C. Jump pin 2 to pin 5,6,7,8,9,10. Valves should pour LARGE.
- D. Jump pin 3 to pin 5,6,7,8,9,10. Valve should pour MEDIUM.
- E. Jump pin 4 to pin 5,6,7,8,9,10. Valves should pour SMALL.

J-17 CALIBRATION BUTTON & LIGHT

If microprocessor does not go into calibration, remove connector at J-17. With jumper wire, jump 1st and 2nd pins on left 3 times in less than 3 seconds. Replace connector. Calibration light should be on (microprocessor will be in the calibration mode). White & White = calibration button. Red & Black = calibration light. If CAL light does not come on LED is burned out — replace keyboard.

Dual Transformers

DUAL TRANSFORMERS MUST BE WIRED IN PHASE

To determine whether transformers are wired in phase: With power on, take voltage reading at HOT wire of each transformer. Reading should be **0 VOLTS***. If you read voltage, transformers are out of phase. The positions of the wires on one transformer must be switched.

*Black to White = 24V AC +/-10%
Black to Black = 0 V AC

New MPC84A Portion Control Board

A new portion control board, the MPC84A, has been developed to improve the performance and maintain the functions and features of the previous MPC64A. In addition this PC board has passed the very demanding EMC testing (radio frequency emissions and interference) for European CE approval, at the UL labs. The MPC64A has been phased out as of 6/96 and only the MPC84A will be used on new production and service.

The new board is the same size, same mounting locations, and uses the same connectors as the previous board. This article is to explain some minor differences and features which can be used to your advantage.

The major difference is with the same size board, the MPC84A can control up to eight stations (dispensing valves), with up to four sizes per station. The MPC64A could only control up to six stations.

The first drawing depicts the connectors on the MPC64A.

The second drawing depicts the connectors on the MPC84A.

The Power connectors J15 and J20 (24VAC) are the same. The Keyboard connectors J16 for touchpad sizes and J17 for calibration touchpad and light, are the same.

The MPC 84A adds one more two pin keyboard connector J1. For an eight station tower, this connector, along with a separate two wire cable to the proper Keyboard, provides the two extra stations.

The five pin valve connectors, J7 to J12 on the MPC64A are changed to two pin connectors, J7 to J14 on the MPC84A. These valve connectors are not polarized (does not matter how you connect the two pins) except when the valve has a WATER or SODA harness.

The calibrating functions of the new portion control board are the same as the old board.

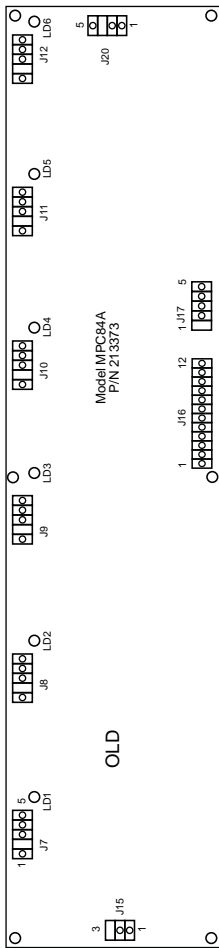

MPC64A Connectors

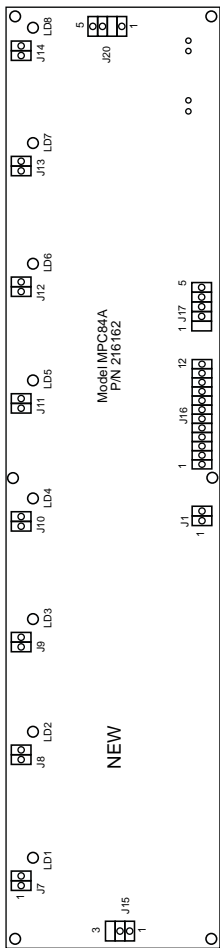

MPC84A Connectors

FEATURES OF THE NEW MPC84A

- Can control up to 8 stations (valves).
- Hardware isolation and zero switching to minimize electrical problems.
- Software improvements to noise.

CALIBRATION INSTRUCTIONS

(same as MPC64A)

1. To enter calibrate mode, press calibrate switch three times in less than three seconds, and red calibrate light will illuminate.
2. Place volume cup under nozzle of the valve to be calibrated.
3. Press appropriate size switch and fill volume cup to a point just short of the calibration mark on the volume cup.
4. Let foam settle, jog size switch until liquid reaches the appropriate calibration mark on the volume cup.
5. To calibrate additional sizes, repeat steps 2 thru 4.

Special Features when in the Calibrate Mode

- To obtain an accurate 4.0 seconds pour from any valve, press its associated STOP-FILL switch once.
- To adjust all stations for the same size times, press any station STOP-FILL switch twice in less than two seconds, then repeat steps 2 thru 4 at this station. The resulting times will be copied to all stations when calibrate mode is exited.

Important

Use this mode, one size adjusts all, only for an emergency (no time to adjust at all) and temporarily. Each valve flow rate, ratio, and flow regulators would have to be perfectly identical for each valve to duplicate the same volume in the same portion time.

6. To exit the calibrate mode, press calibrate switch once and red calibrate light will go out.

NOTE: The new MPC84A does not have factory default set times, like the MPC64A does. If a portion size or station loses its calibration, the time(s) will go back to minimum (.5 seconds). This means you can check the total operation of the MPC84A by initiating the TEST/CYCLING option, without changing the calibration times, which could happen with the old MPC64A.

TEST / CYCLING OPTION

1. Turn the power OFF to the tower/portion control.
2. Hold the calibrate switch ON and turn the power ON at the same time.
3. The calibrate LED will illuminate, let OFF the calibrate switch.
4. The dispensing valves will sequence from left to right, valve #1 ON 4 seconds, then valve #2 ON 4 seconds etc., continuously repeating, until you turn the power OFF, or press the calibrate button once. This allows you to see that all valves work. The keyboard or valve harness would have to be at fault, if all the circuit board LEDs (LD1-LD8) illuminate properly, and a valve or valves do not dispense.

Secondly, this sequencing can be used to purge or sanitize the system automatically. If you want more than one valve at a time to dispense automatically for 4.0 seconds, just press station number for number of valves simultaneously. That is, when in the cycling sequence press station #2 (counting left to right) for two valves simultaneous, meaning valve #1 and #2 will dispense for 4 seconds, then #3 and #4, etc., continuously repeating until you turn the power OFF or press the calibrate button once. If you press the station #3, then 1 and 2 and 3 stations will dispense simultaneously, then 4 and 5 and 6, etc. This allows you to have as many valves purging/sanitizing, as the drain will allow without overflowing.

RETROFITTING

When using the MPC84A as a service replacement part, only the valve connectors have to be watched. The power connectors and the keyboard connectors

are the same and go in the same places. The older 5 pin valve connectors will fit on the new board, as long as you observe that the 5 pin connector goes on with the two wires aligned to the two pins on the new board. In case of the WATER and SODA switch harness, it must be polarized, so reverse (connector moved 180°) if WATER or SODA does not pour.

MOVs Field Testing

Metal Oxide Varistors installed on the water and carbonated water buttons on, McDonalds style dispensing towers, are designed to completely absorb electrical spikes keeping them out of the microprocessor circuit eliminating complaints of:

- Not holding calibration
- Valves flowing by themselves
- Two valves coming on at the same time, etc.

Multiplex has designed a field test procedure that will expose a faulty MOV. This procedure will also work on the older style capacitors.

The field test procedure:

Depress **separately** both the water and soda water button rapidly 5 - 6 times. While doing this, watch all other valves. If you notice any dripping or any other valve trying to energize, the MOVs need to be replaced.

NOTE: Factory installed MOVs have heat shrink tubes on each terminal leg. Always check to make sure that heat shrink has not slipped down and is insulating the MOV leg inside the terminal connector.

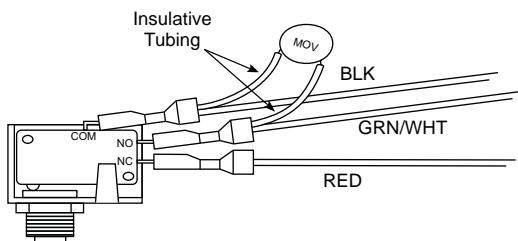

Test Procedures: MPC84C Timer/ Selection Board

MPC 84B timers can be placed in the test mode as follows:

1. Flip power switch OFF.
2. While depressing CAL button on selection pad, flip power switch ON.
3. Release CAL button when red LED comes on.

Faucets will energize for 4 seconds, each in sequence, starting with faucet #1 (far left). Timer is now in the Test Mode. To stop faucets, use one of two procedures.

- Turn power switch off. This will save the programmed times. Use this procedure for testing or sanitizing.
- Push CAL. All programmed times will be saved.

PIN IDENTIFICATION

J-1 = Valve 1 J-6 = Valve 6

J-2 = Valve 2 J-7 = Valve 7

J-3 = Valve 3 J-8 = Valve 8

J-4 = Valve 4 J-9 = Soda

J-5 = Valve 5 J-10 = Water

Check for 24 Volts at each solenoid cable connector, J-1 through J-8, with cables removed.

With cables on, check for 24VAC across solenoids at dispensing valve while dispensing respective valve.

J-15 Power to valves 1, 2, 3, 4 and microprocessor

J-20 Power to valves 5, 6, 7, 8 and microprocessor

Loss of power at J-15 results in loss of power to valves 1, 2, 3, and 4.

Loss of power at J-20 results in loss of power to valves 5, 6, 7, and 8.

J-16 Station and Sizes:

#1	Stop/Fill
#2	Large
#3	Medium
#4	Small
#5	Valve 6
#6	Valve 5
#7	Valve 4
#8	Valve 3
#9	Valve 2
#10	Valve 1
#11	Blank
#12	Extra Large

J-18 Stations

#1	Valve 7
#2	Valve 8

J-19 Stations and Sizes:

#1	Blank
#2	Valve 2 or 4 Flavor 1
#3	Valve 2 or 4 Flavor 2
#4	No wire
#5	Kid Size (Smallest)

Use a jumper wire to make these connections to determine if timer is functioning properly.

1. Jump pin 1 on J-16 to pin 5, 6, 7, 8, 9, 10, and pins 1 and 2 on J-18. Appropriate valve should energize as long as pins are jumped.
2. Jump pin 12 on J-16 to 5, 6, 7, 8, 9, 10, and pins 1 and 2 on J-18. Valves should pour Extra Large.
3. Jump pin 2 on J-16 to 5, 6, 7, 8, 9, 10, and pins 1 and 2 on J-18. Valves should pour Large.
4. Jump pin 3 on J-16 to 5, 6, 7, 8, 9, 10, and pins 1 and 2 on J-18. Valves should pour Medium.
5. Jump pin 4 on J-16 to 5, 6, 7, 8, 9, 10, and pins 1 and 2 on J-18. Valves should pour Small.
6. Jump pin 5 on J-19 to J-16 pins 5, 6, 7, 8, 9, 10, and pins 1 and 2 on J-18. Valves should pour Kid Size.

J-17 CALIBRATION BUTTON AND LIGHT

If microprocessor does not go into calibration, remove connector at J-17. With jumper wire, jump 1st and 2nd pins on left 3 times in less than 3 seconds. Replace connector. Calibration light should be on (microprocessor will be in the calibration mode). White & white = calibration button. Red & black = calibration light. If CAL light does not come on, LED is burned out — replace keyboard.

SECONDARY BOARD PIN IDENTIFICATION

J-1 = Valve 2 Flavor 1

J-2 = Valve 2 Flavor 2

J-3 = Valve 4 Flavor 1

J-4 = Valve 4 Flavor 2

Use a jumper wire to make these connections to determine if timer is functioning properly.

1. Jump pin 2 or 3 on J-19 and pin 7 or 9 on J-16.
Then jump pin 1 on J-16 to pin 7 or 9 on J-16.
Appropriate valve should energize as long as pins are jumped.
2. Jump pin 2 or 3 on J-19 and pin 7 or 9 on J-16.
Then jump pin 12 on J-16 to pin 7 or 9 on J-16.
Appropriate valve should pour Extra Large.
3. Jump pin 2 or 3 on J-19 and pin 7 or 9 on J-16.
Then jump pin 2 on J-16 to pin 7 or 9 on J-16.
Appropriate valve should pour Large.
4. Jump pin 2 or 3 on J-19 to pin 7 or 9 on J-16.
Then jump pin 3 on J-16 to pin 7 or 9 on J-16.
Appropriate valve should pour Medium.
5. Jump pin 2 or 3 on J-19 to pin 7 or 9 on J-16.
Then jump pin 4 on J-16 to pin 7 or 9 on J-16.
Appropriate valve should pour Small.
6. Jump pin 2 or 3 on J-19 to pin 5 on J-19. Then
jump pin 5 on J-19 to pin 7 or 9 on J-16.
Appropriate valve should pour Kid Size.

Back-flow Preventer Maintenance

The integral carbonator in this unit is equipped with a back-flow preventer designed to protect the potable water supply from CO₂ contamination.

Important

The back-flow preventer must be checked at least once every year to confirm that it is functioning properly.

1. Shut OFF power to unit.
2. Shut OFF potable water supply to unit. Do not shut OFF CO₂ supply.
3. Remove top cover panel of unit and disconnect inlet fitting from back-flow preventer.

NOTE: The carbonator tank is still pressurized.

4. Observe inlet of backflow preventer #1 check for any discharge. If there is no discharge, #1 check is OK. Proceed to step 5. If there is discharge, proceed to step 6.
5. Disconnect and carefully remove #1 check assembly. Avoid losing any internal parts.
6. Observe inlet of #2 check for any discharge. If there is no discharge, #2 check is OK. Proceed to step 7. If there is discharge, proceed to step 5.
7. Shut OFF CO₂ supply and relieve pressure from carbonator tank.
8. Remove back-flow preventer and install new backflow preventer. Turn ON CO₂ supply and check for leaks.
9. Check water supply strainer upstream of backflow preventer. Clean out and/or replace as required.
10. Reconnect water lines and turn water supply ON.
11. Turn ON power to unit.

Head Pressure Control Valve

Multiplex remote systems require head pressure control valves with special settings. Replace defective head pressure control valves only with “original” Multiplex replacement parts.

OPERATION

The R404A head pressure control valve is non adjustable.

At ambient temperatures of approximately 70°F (21°C) or above, refrigerant flows through the valve from the condenser to the receiver inlet. At temperatures below this (or at higher temperatures if it is raining), the head pressure control dome’s nitrogen charge closes the condenser port and opens the bypass port from the compressor discharge line.

In this modulating mode, the valve maintains minimum head pressure by building up liquid in the condenser and bypassing discharge gas directly to the receiver.

DIAGNOSING

1. Determine if the coil is clean. Air passes through the condenser from the bottom up. Verify the coil is clean by looking from the bottom up. Do not look down through the fan.
2. Determine the air temperature entering the remote condenser.
3. Determine if the head pressure is high or low in relationship to the outside temperature. (Refer to the proper “Normal Operating Pressures of Refrigeration Units” in the Charts section.)
4. Determine the temperature of the liquid line entering the receiver by feeling it. This line is normally warm; “body temperature.”
5. Using the information gathered, refer to the chart below.

NOTE: A head pressure control valve that will not bypass, will function properly with condenser air temperatures of approximately 70°F (21°C) or above. When the temperature drops below 70°F (21°C), the head pressure control valve fails to bypass and the ice machine malfunctions. Lower ambient conditions can

be simulated by rinsing the condenser with cool water during the freeze cycle.

Condition	Probable Cause	Corrective Measure
Discharge Pressure - High Liquid Line Temperature - Hot	Valve stuck in bypass	Replace valve
Discharge Pressure - Low Liquid Line Temperature - Cold	Valve not bypassing	Replace valve
Discharge Pressure - Low Liquid Line Temperature - Hot	Ice Machine Low on Charge	Low on Charge Verification

FAN CYCLE CONTROL VS. HEAD PRESSURE CONTROL VALVE

A fan cycle control cannot be used in place of a head pressure control valve. The fan cycle control is not capable of bypassing the condenser coil and keeping the liquid line temperature and pressure up.

This is very apparent when it rains or the outside temperature drops. When it rains or the outside temperature drops, the fan begins to cycle on and off. At first, everything appears normal. But, as it continues raining or getting colder, the fan cycle control can only turn the fan off. All the refrigerant must continue to flow through the condenser coil, being cooled by the rain or low outside temperature.

This causes excessive sub-cooling of the refrigerant. As a result, the liquid line temperature and pressure are not maintained for proper operation.

Charging Multiplex Remote Refrigeration Unit

NOTE: System would have been opened for repairs. Once completed, a vacuum of 500 microns would have been maintained for 1/2 hour. The proper procedure for charging the system includes the reintroduction of all refrigerant that had been recovered before making the repair.

1. Attach charging hose of gauge manifold to liquid valve of the recovery cylinder (if no refrigerant was in the system, and thus, no refrigerant was recovered, attach charging hose to Refrigerant cylinder). Open cylinder valve.
2. Place cylinder on charging scale-zero scale.
3. Open high side valve wheel of gauge manifold.
DO NOT ATTEMPT TO CHARGE SYSTEM ON LOW SIDE—CHARGE IN A LIQUID STATE ONLY WITH REFRIGERATION SYSTEM OFF.
4. Allow sufficient time for all refrigerant to transfer from cylinder to refrigeration unit. If necessary, put cylinder into bucket of hot water to increase the internal pressure of the cylinder.
5. System total charge is the net result of:
 - A. Refrigeration Unit charge on nameplate
 - B. Remote line set length X .72 oz./ft.
 - C. 90% of condenser volume (cu. ft.) x Refrigerant (wt./cu ft)

NOTE: Refrigerant weight varies with temperature. R-404A weighs 72 lb/cu. ft. @ 32°; 62 lb/cu. ft. @ 95°

6. When all refrigerant has been transferred, close valve wheel of the manifold.
7. Turn refrigeration unit on.

Compressor & Remote Condenser

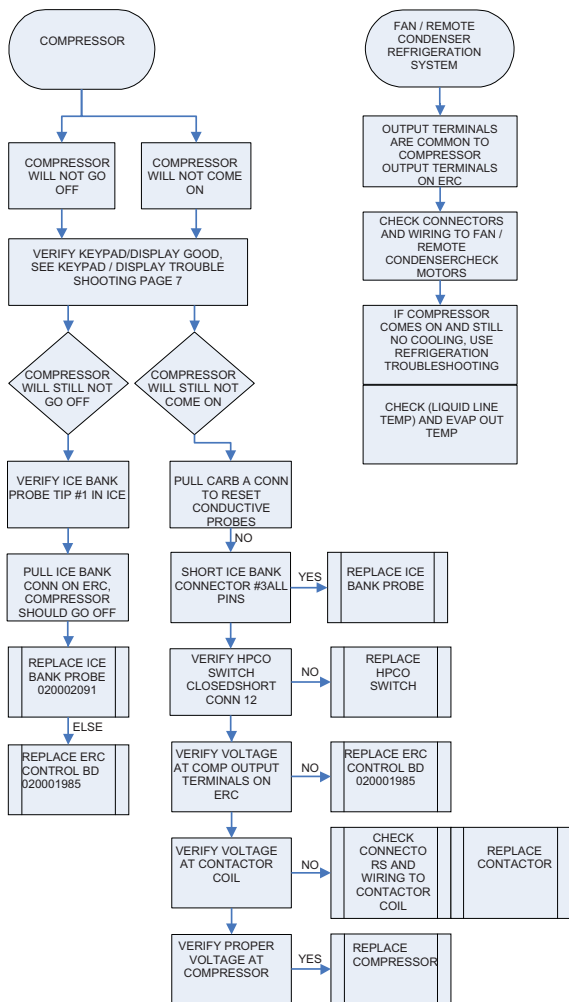

Agitator Condenser

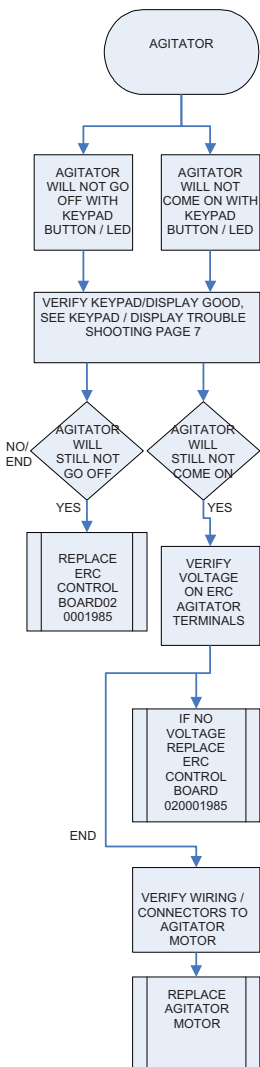

Carbonation System A or B

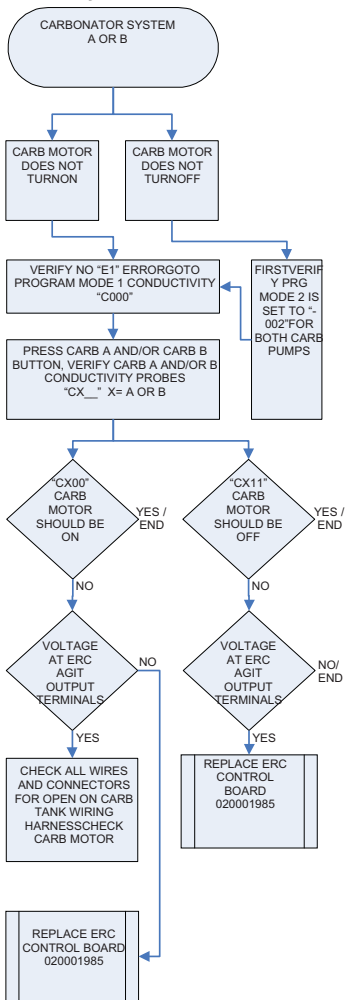

Circulation System A or B

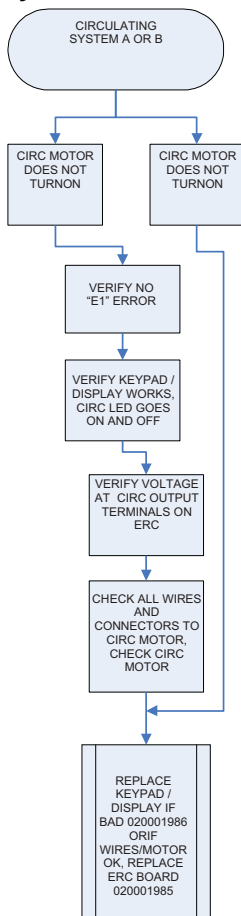

ERC Control Board, Keypad & Display

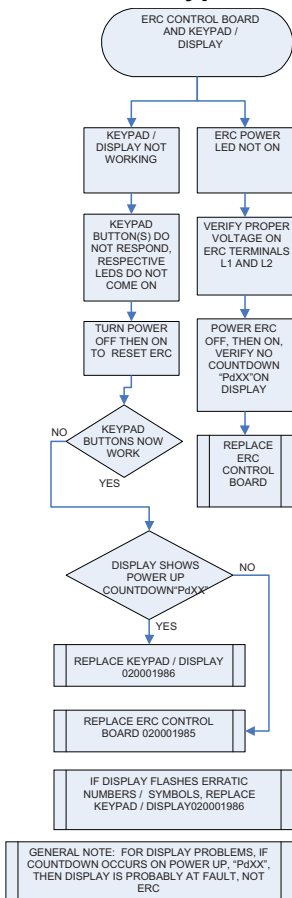

Programming / Auto Set

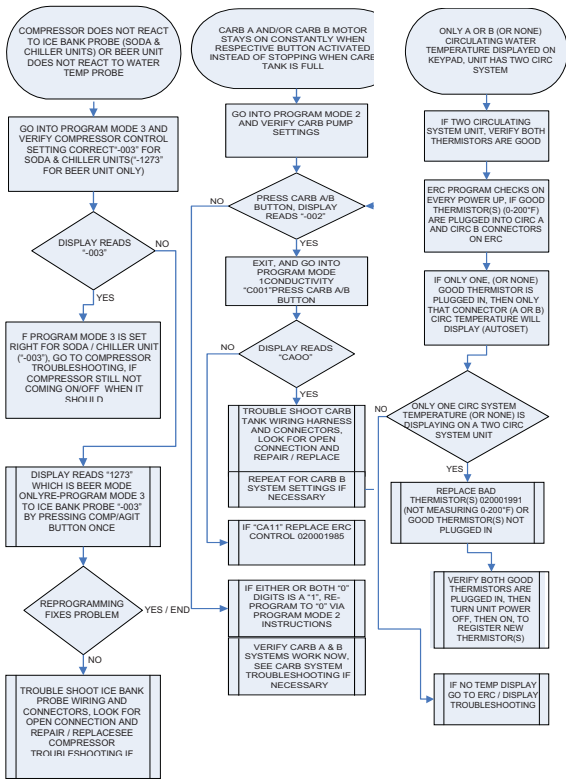

ERC Component (Output) Connector Layout

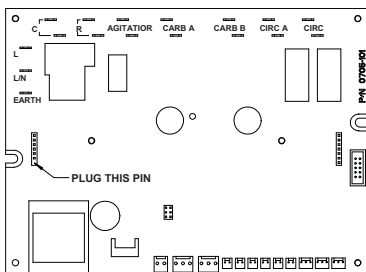

ERC Sensor (Input) Connector Layout

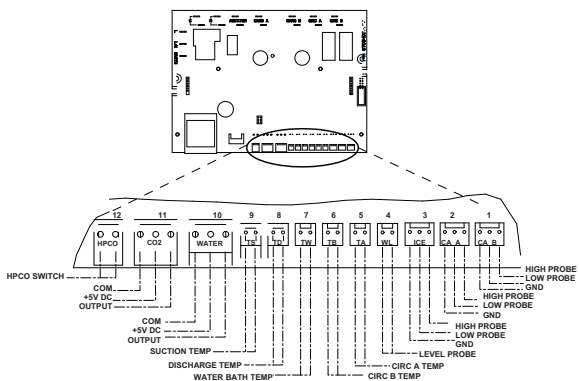

Component Specifications

Refrigeration Unit Specifications

Model	Number of Dispensing Heads	Type of Container
2803	One 6-valve soda tower	Bag-in-Box
11M	One 6-valve soda tower or up to three 2-valve root beer towers	Bag-in-Box
44M & 42M	Up to two 8-valve soda towers	Bag-in-Box
50M	Up to two 8-valve soda towers	Bag-in-Box

Super-Chill units do not apply to the above table, they are only used to chill large amounts of water.

RATINGS

Model	Evaporator Rating at 20°F (-6.5°C)	Heat Rejection (Max.)
Model 2803	2,500 BTUH 490 kcal/hr	4,500 BTUH 885 kcal/hr
Model 11M	5,150 BTUH 1,159 kcal/hr	8,638 BTUH 1,949 kcal/hr
Models 44M & 42M	9,700 BTUH 2,340 kcal/hr	13,576 BTUH 3,685 kcal/hr
Model 50M	14,900 BTUH 3,310 kcal/hr	20,400 BTUH 4,285 kcal/hr

S-250M Specifications

Countertop Weights	175 lbs./79.5 kgs
Ice Storage Capacity	up to 250 lbs./ 114 kgs of ice.
Electrical Requirements	Dispenses: 120V/60Hz/2.8 FLA
Drain	Two 3/4" (1.96 cm) PVC (N.P.T.) drain fittings. One pre-installed 3/4" (1.96 cm) PVC fitting extends from drain pan. A second fitting extends from bin.
Machine Compatibility	Manual fill or top-mount with compatible 22" and 30" wide ice machines. Contact factory for baffle and ice wide ice machines.
Service	Motor, drain and electrical connections are front serviceable.

MII-302 Specifications

Countertop Weights	402 lbs. / 182 kgs
Ice Storage Capacity	300 lbs. / 136 kgs
Electrical Requirements	Dispenser: 120V/60Hz/3.5 FLA
Drain	Two pre-installed 3/4" (1.9 cm) PVC (N.P.T.) drain fittings extend from drain pan. Ice bin drains directly into drain pan for front clean out, no hook up necessary.
Machine Compatibility	Manual fill or top-mount with compatible 30" wide ice machine. Certain top-mounted machines may reduce storage capacity. Contact distributor or Manitowoc Foodservice for baffle and ice maker lid requirements for top-mounted ice machine applications.
Service	Motor, drain and electrical connections are front serviceable.

Charts

Refrigerant Charge

R-12		
MODEL	P/N	R-12 OZS/GRAMS
16 EUTECTIC	200847	10/1304.1
37A	903750	73.6/2086.5
37W	903751	80/2267.9
37R	903753	194/5499.8
37TA	903770	74/2097.8
37TR	903771	172/4876.1
37TW	903772	80/2267.9
38HA	903801	18/510.3
38HW	903803	23/652.1
38HR	903804	98/27782
72AL	904666	49-1389.1
72WR	904667	57/1615.9
72WL	904668	57/1615.9
72LR	904682	151/4280.7
72RR	904683	151/4280.7
37AF	904707	74/2097.8
37RF	904708	172/4876.1
37WF	904709	80/2267.9
50A	905008	46/1304
50RC	905009	134/3798.8
50W	905010	57/1615.9
50HA	905011	36/1020.6
50HW	905012	44/1247.4
50HR	905013	150/4252.4
38A	905210	26/737.1
38R	905211	31/878.8
38W	905223	64/1814.3
51AEUTECTIC	905224	46/1304.1
2803A	902801	8/226.8
2803W	902803	6/170.1
1200A		32/907.2
1200W		36/1020.6

R-12 (Continued)		
MODEL	P/N	R-12 OZS/GRAMS
2803W	902805	6/170.1
11AS	903722	12/340.2
37KA	903730	74/2097.8
37KR	903731	172/4876.1
37KW	903732	80/2267.9
38HAC	903806	18/510.3
38HAC	903807	18/510.3
38HAC	903808	18/510.3
39	903939	98/2778.2
39SC	903940	98/2778.2
D4610	904601	67.5/1913.6
37RF-1	904701	172/4876.1
371A	904710	74/2097.8
371R	904711	172/4876.1
371W	904712	80/2267.9
50HA-1	905017/20	36/1020.6
50FW-1	905018/24	44/1247.4
50HR-1	905019/22	150/4252.4
75A	907501	8/226.8
125A	912501	6/170.1
150A	915001	12/340
D4205A	942050/51	16/453.6
2000A		26/737.1
2000W		31/878.8
44KA	904419	25/708.7
44KR	904420	128/3628.7
44KW	904421	22/623.7 R502
44A	904400	25/708.7
44R	904401	128/3628.7
44R	904405	98/2778.2
44W	904406	22/623.7 R502

R-22		
MODEL	P/N	R-22 OZS/GRAMS
11MA	901106	11/312
11MA2C	901108	11/312
150MA-1	915011	11/312
37KA22	903790	64/1814
37KR22	903791	151/4281
37KW22	903792	70/1984
37MA-P	904725	64/1814
37MR-P	904726	151/4281
37MW-P	904727	70/1984
44KA22	904440	47/1332
44KR22	904441	116/3289
44MR-G	904431	116-3289
44MR-P	904500	47/1332
44MW-G	904432	35/992
50MA	905030	42/1191
50MR	905031	140/3969
50MR	905036	140/3969
50MW	905032	52/1474
75A	907511	7/198
HC180	902809	7/198
HC340	901109	11/312
HC340S	901111	11/312
R2803A	902821	7/198
R2803W	902822	7/198

R-404A		
MODEL	P/N	R-404A OZS/GRAMS
11M042C	901125	13.5/383
11MA04	901120	13.5/383
150A04	905121	13.5/383
2803A04	902830	10.5/298
2803A04B	902838	10.5/298
300MA04	930021	57/1616
3610R404C	936116	240/6804
38MA04	903850	39/1106
38MA04B	903859	39/1106
38MW04B	903855	29.5/836
38MW04	903852	26/737
44KA04	904490	57/1616
44KR04	904491	125/3544
44KW04	904492	57/1616
44MA04	904480	57/1616
44MA04E	904416	57/1616
44MR04	904481	125/3544
44MR04E	904417	125/3544
44MW04	904482	57/1616
44MW04E	904418	57/1616
450MA04	945013	113/3203
50MA04	905040	113/3203
50MR04	905041	145/4111
50MR04	905046	145/4111
50MW04	905042	113/3203
75A04	907521	10.5/298
D3610-04	936113	240/6804
D4810R04	948102	240/6804
HC900-04	903856	29/822
HC900S04	903858	29/822

Operating Pressures

NORMAL OPERATING PRESSURES OF REFRIGERATION UNITS

	R-12	R-502	R-22	R-134A	R-404A
Head Pressure	psig	psig	psig	psig	psig
75°F Condenser Ambient 10-100% Ice on Evaporator	100-140	200-260	180-240	110-160	210-280
90°F Condenser Ambient 10-100% Ice on Evaporator	120-170	230-300	210-280	130-180	240-320
	R-12	R-502	R-22	R-134A	R-404A
Evaporator Pressure	psig	psig	psig	psig	psig
75°F Evaporator, or 80°F Water	75	140	130	75	150
10-100% Ice on Evaporator	9-20	30-50	24-44	9-20	33-55

1. On system with expansion valve (pressure limiting) evaporator gets no higher than:
50 psig on R-12
53 psig on R-502
85 psig on R-22
2. Water system head pressure should be manually set (adjustable water control valve) to maintain 105°F water condenser out temperature.
3. Remote Condenser system head pressure will be controlled by Low Ambient Control
75 psig on R-12, R-134A
150 psig on R-502, R-22, R-404A

NORMAL OPERATING PRESSURES OF REFRIGERATION UNITS

	R-12	R-502	R-22	R-134A	R-404A
Head Pressure	bar	bar	bar	bar	bar
24°C Condenser Ambient 10-100% Ice on Evaporator	6.9-9.7	13.8-17.9	12.4-16.5	7.6-11.0	14.5-19.3
90°F Condenser Ambient 10-100% Ice on Evaporator	8.3-11.7	15.9-20.6	14.5-19.3	8.9-12.4	16.5-22.1
	R-12	R-502	R-22	R-134A	R-404A
Evaporator Pressure	bar	bar	bar	bar	bar
24°C Evaporator, or 27°C Water		9.7	9		10.3
10-100% Ice on Evaporator	0.6-1.4	2.1-3.4	1.7-3.0	0.4-1.2	2.3-3.8

1. On system with expansion valve (pressure limiting) evaporator gets no higher than
3.4 bars on R-12
3.7 bars on R-502
5.9 bars on R-22
2. Water system head pressure should be manually set (adjustable water control valve) to maintain 40.5°C water condenser out temperature.
3. Remote Condenser system head pressure will be controlled by Low Ambient Control
5.2 bars on R-12, R-134A
10.3 bars on R-502, R-22, R-404A

McDonald's Models History

	Model	Baths	Circulating Pump GPH	Carb. Water Line Size	Flow
1969	1200	Twin	Two 50 GPH	3/8" ID	Slow
1973 (late)	1200	Twin	Two 50 GPH	3/8" ID	Slow
1978 (late)	72	Twin	Two 100 GPH	1/2" ID	Slow/Fast
1979 (early)	36*	Single	Two 100 GPH	1/2" ID	Slow/Fast
1981 (late)	37	Single	Two 100 GPH	1/2" ID	Slow/Fast
1982 (late)	37F (Fast Flow)	Single	Two 100 GPH	1/2" ID	Fast
1987 (mid)	37T (Total PSI)	Single	Two 100 GPH	1/2" ID	Fast
1990 (late)	37K (Kit)	Single	Two 100 GPH	1/2" ID	Fast
1990 (late)	44K (Kit)	Single	One 100 GPH	1/2" ID	Fast
1992 (mid)	37K-22 (R-22)	Single	Two 100 GPH	1/2" ID	Fast
1992 (mid)	Cold Plate	N.A.	N.A.	1/2" ID	Fast
1992 (mid)	44K-22 (R-22)	Single	One 100 GPH	1/2" ID	Fast
1995 (mid)	44K-404 (R-404A)	Single	One 100 GPH	1/2" ID	Fast
1995 (late)	50M-04 (R404A)	Single	Two 100 GPH	1/2" ID	Fast

*Only 100 units manufactured.

	Finished Drink @ 5:1 Brix	Soda Only
Slow Flow	6 oz. / 4 sec.	5 oz. / 4 sec.
Fast Flow	12 oz. / 4 sec.	10 oz. / 4 sec.

Sustained Draw Curve Charts

SC180 SUSTAINED DRAW CURVE

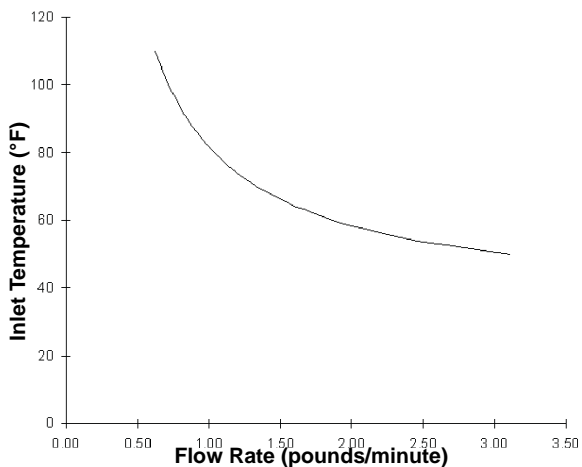

SC340 SUSTAINED DRAW CURVE

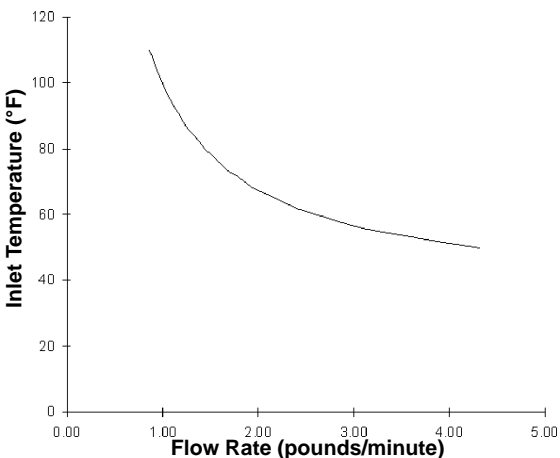

SC1000 SUSTAINED DRAW CURVE

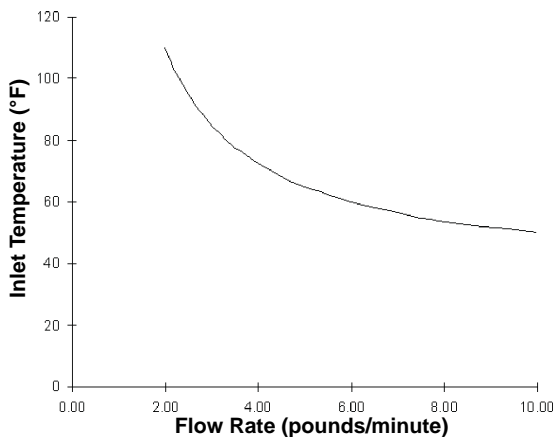

SC2000 SUSTAINED DRAW CURVE

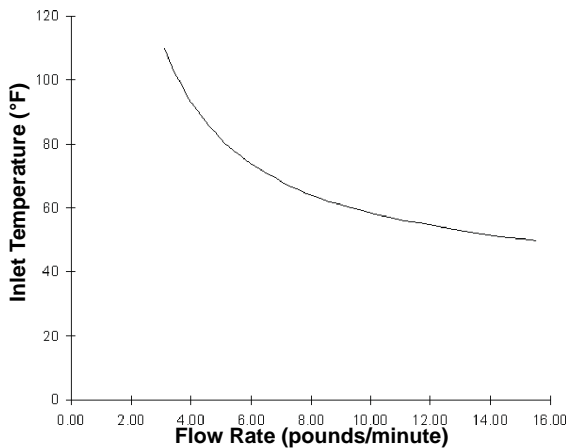

This Page Intentionally Left Blank

MODEL 72/72B AIR COOLED 1 PHASE

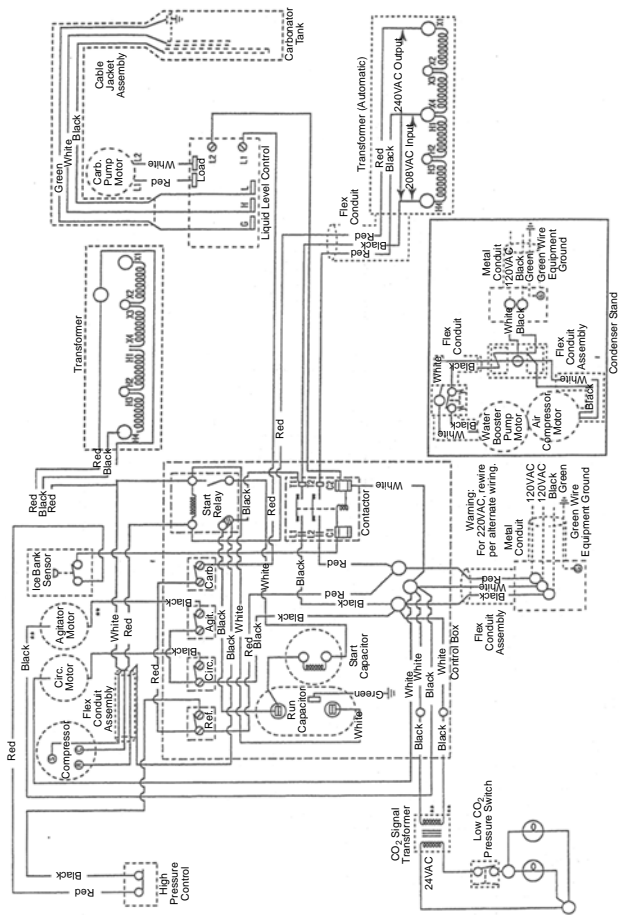

Symbols

- Wire Nut, Small Yellow
- Wire Nut, Large Black
- Wire Attached to Component
- Identified Terminal
- Toggle Switch

Alternate Wiring

When the supply voltage is 230/115 VAC, disconnect autotransformer (0021035) from the circuit.

1. Disconnect incoming power.
2. Remove transformer box cover.
3. Remove wire nut from black lead to H4.
4. Replace wire nut on exposed end of black lead.
5. Remove both red leads from (H1 and X1).
6. Connect red leads together with a wire nut.
7. Replace cover.

MODEL 37T

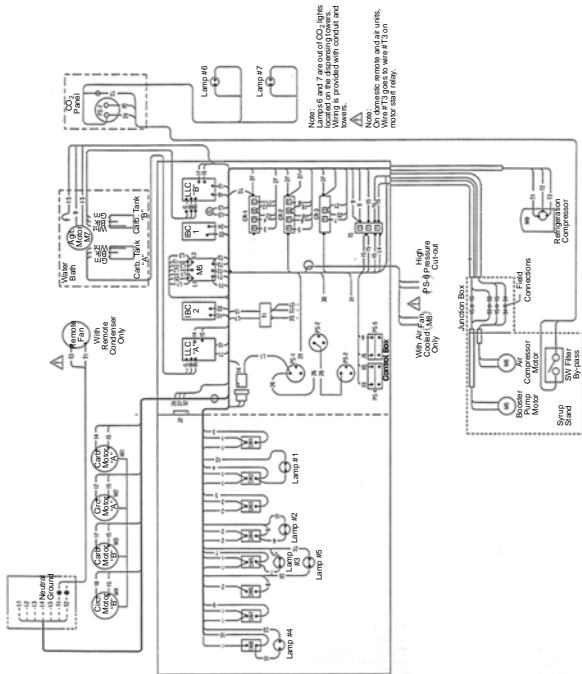

Note:	
MS	Relay Motor Start
SW	Switch
PS	Pressure Switch
CR	Control Relay
LLC	Liquid Level Control
IBC	Ice Bank Control
M	Motor
T	Transformer
J	Connection Receptacle
P	Connector Plug
TS	Terminal Strip

Conductor Color Codes			
Domestic		Export	
L1	Black	L1	Black
L2	Red	L2	Brown
L3	Brown	L3	Brown
L4	White	L4	Lt Blue
L5	Grn/Yel	L5	Grn/Yel

Incoming Power – 3 Phase, 4 wire wiring supplied by installer from junction box to fan.

Note: all switches shown in their normal positions.

MODEL 37T SCHEMATIC DIAGRAM

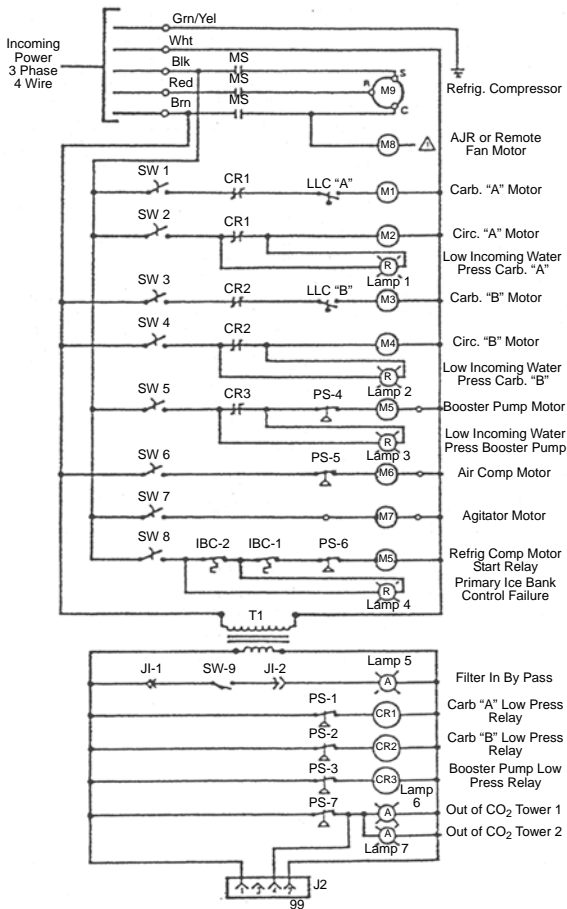

MODEL 37K

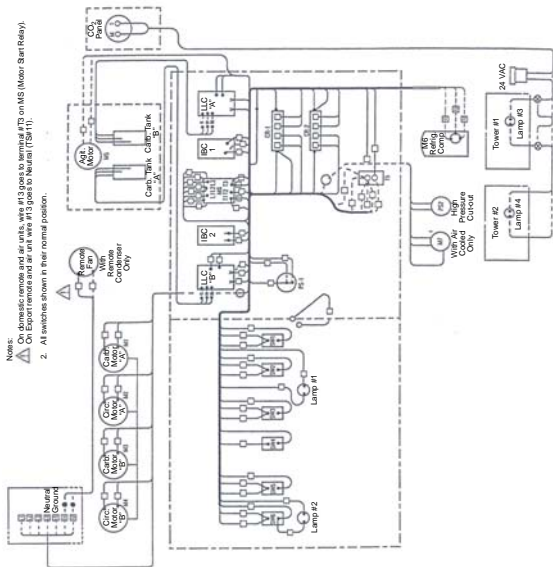

Component Legend	
MS	Relay Motor Start
SW	Switch
PS	Pressure Switch
CR	Control Relay
LLC	Liquid Level Control
IBC	Ice Bank Control
M	Motor
TS	Terminal Strip

Conductor Color Codes			
Domestic		Export	
L1	Black	L1	Black
L2	Red	L2	Brown
L3	Brown	L3	Brown
L4	White	L4	Lt Blue
L5	Grn/Yel	L5	Grm/Yel

Note: Out of CO₂ (24 Y) lamps #3 and #4 located on dispensing towers wiring supplied with conduit and towers. For Schematic wiring see tower wiring diagram.

Incoming Power – 3 Phase, 4 wire wiring supplied by installer from junction box to fan.

MODEL 37K SCHEMATIC DIAGRAM

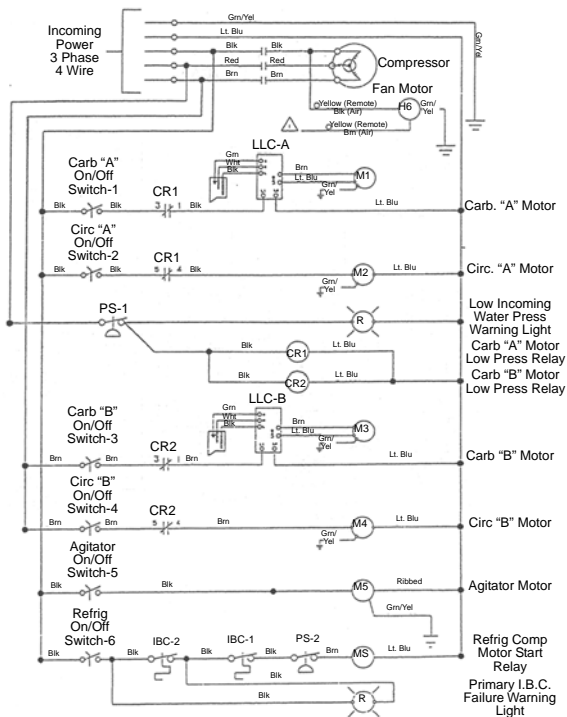

MODEL 44A & R WIRING DIAGRAM

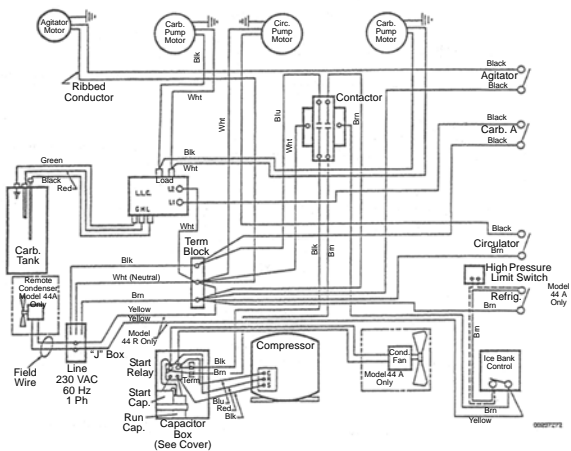

MODEL 44K WIRING DIAGRAM

208-230/60Hz 1 Phase

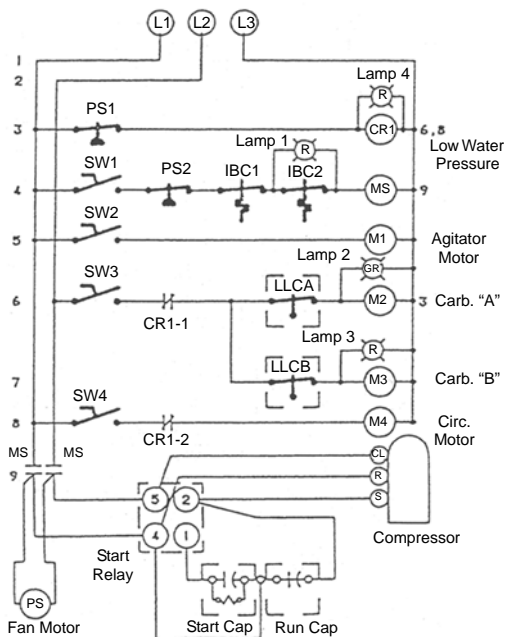

Component Legend

MS	Relay Motor Start
SW	Switch ON/OFF
PS	Pressure Switch
CR	Control Relay
LLC	Liquid Level Control
IBC	Ice Bank Control
M	Motor
TS	Terminal Switch

MODEL 44K22



MODEL 44M04 SCHEMATIC DIAGRAM

208-230 1 Phase

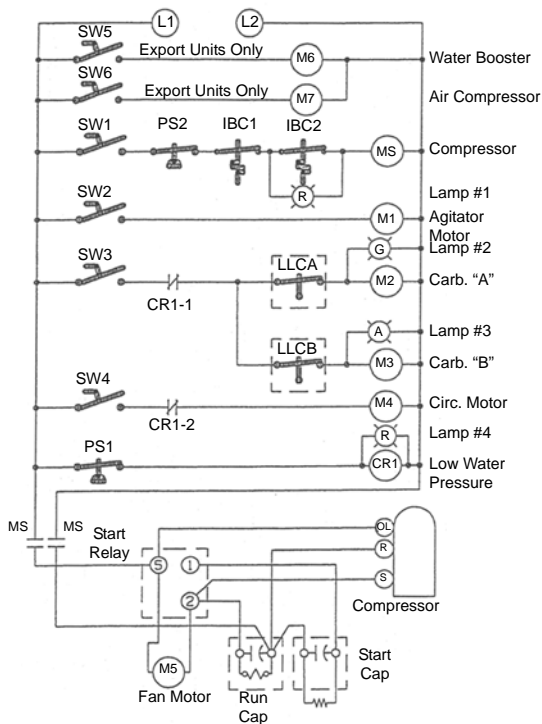

Component Legend

MS	Relay Motor Start
SW	Switch ON/OFF
PS	Pressure Switch
CR	Control Relay
LLC	Liquid Level Control
IBC	Ice Bank Control
M	Motor
TS	Terminal Switch

MODEL 50H

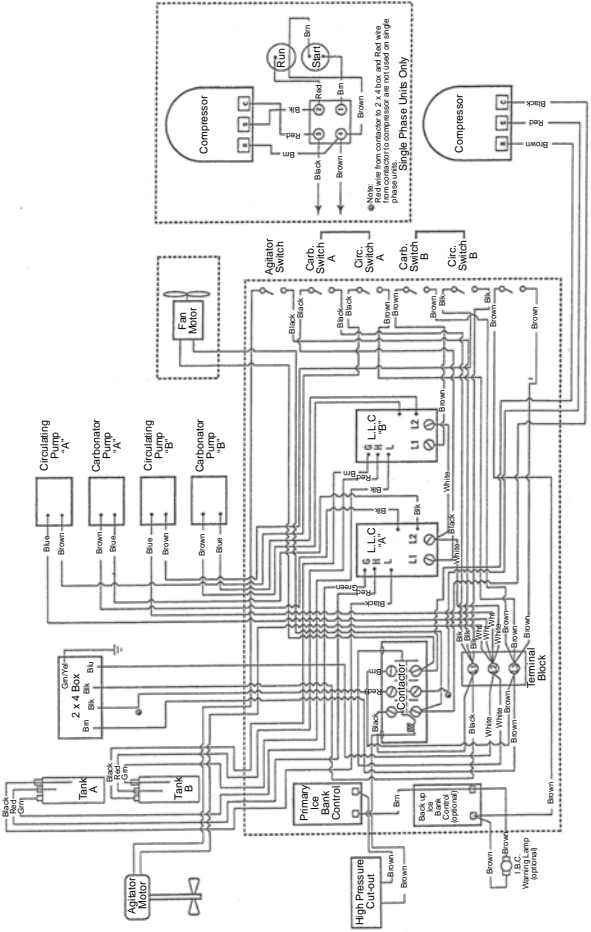

MODEL 50M04

120-208/240 60Hz 3 Phase

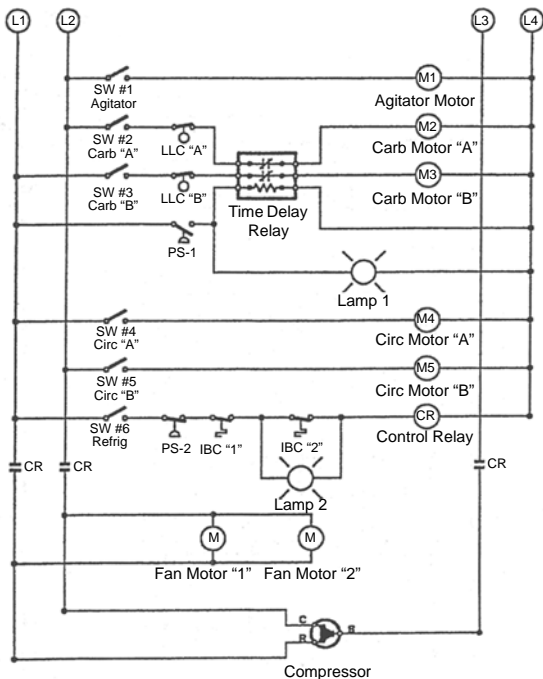

Component Legend

MS	Relay Motor Start
SW	Switch ON/OFF
PS	Pressure Switch
CR	Control Relay
LLC	Liquid Level Control
IBC	Ice Bank Control
M	Motor
TS	Terminal Switch

FRONT DRAW TOWER WIRING DIAGRAM

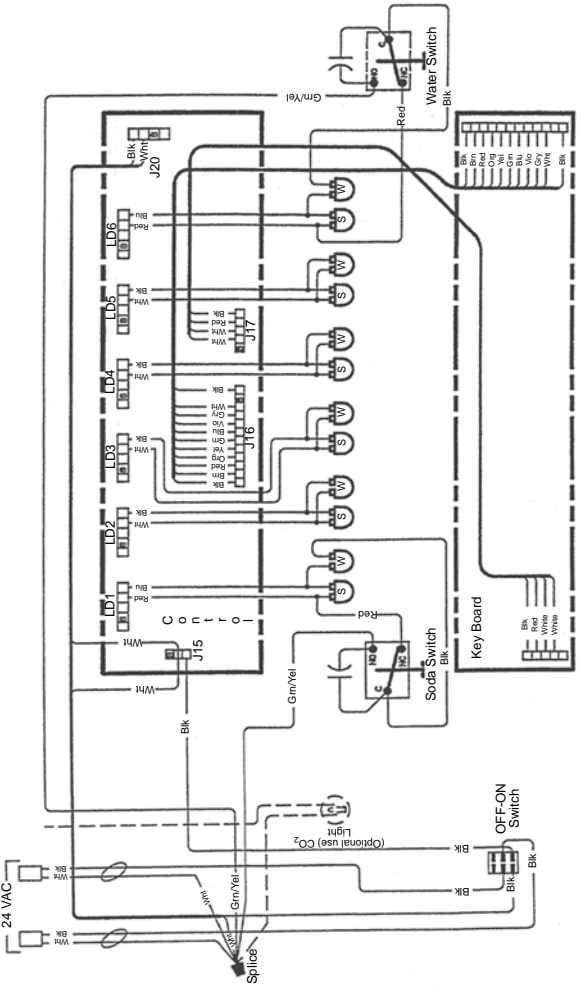

PASS-THROUGH TOWER WIRING DIAGRAM

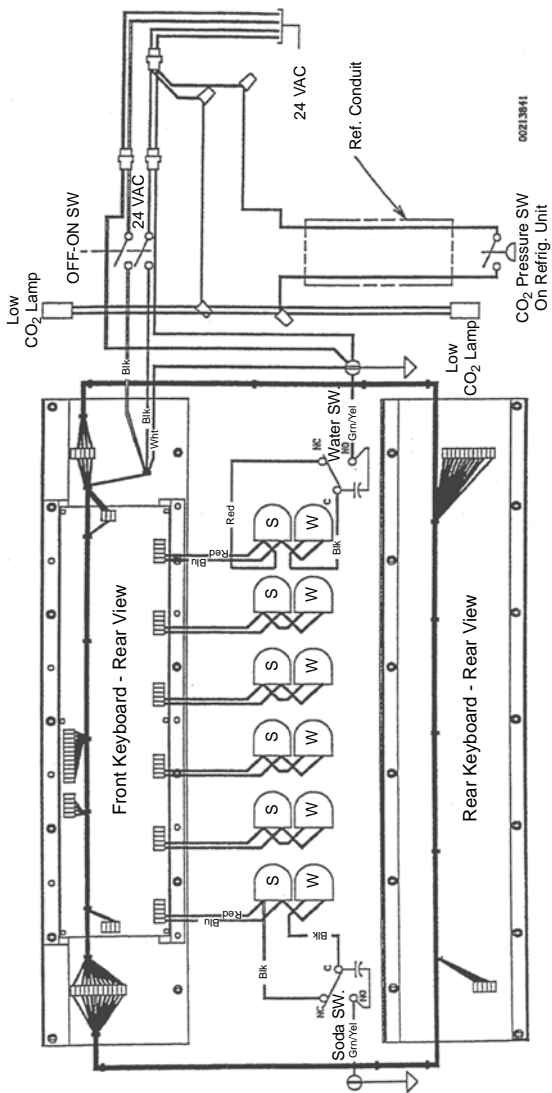

MODEL 2803 (230V 60 HZ)

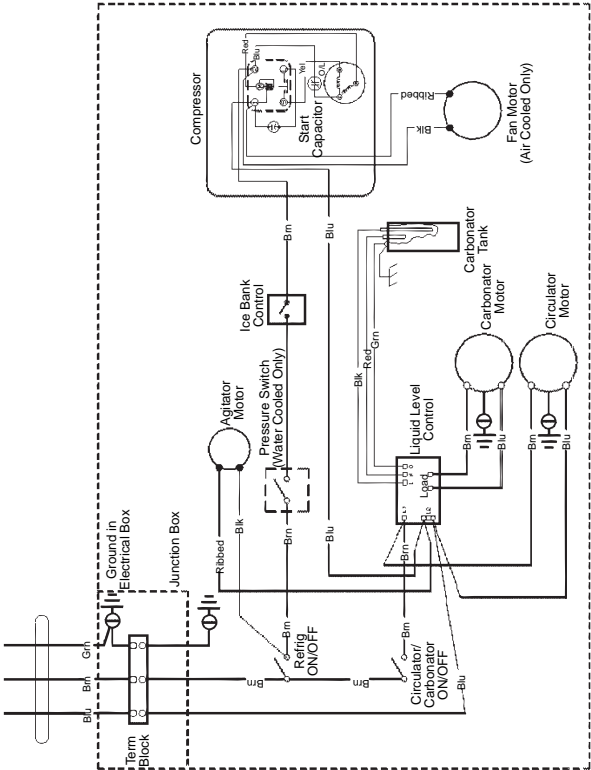

MODEL 2803 INTERNATIONAL (230V 50 HZ)

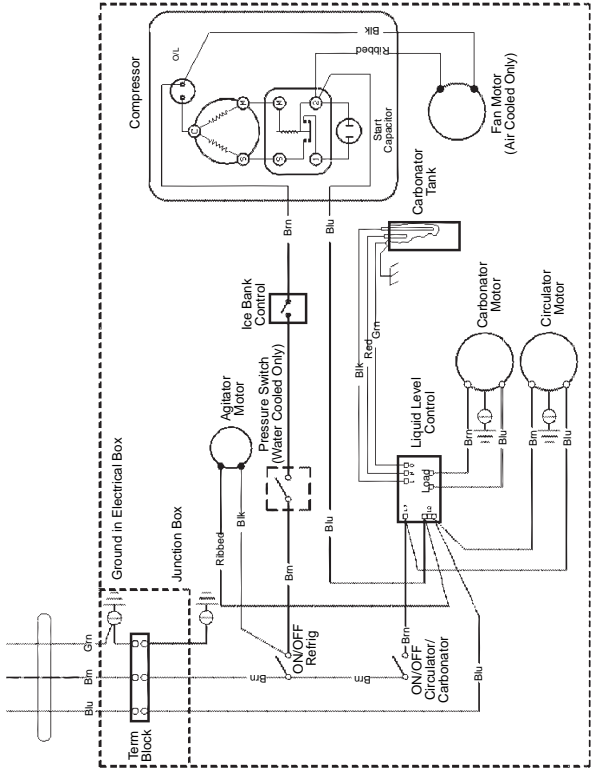

MODEL 2803 ELECTRONIC IBC

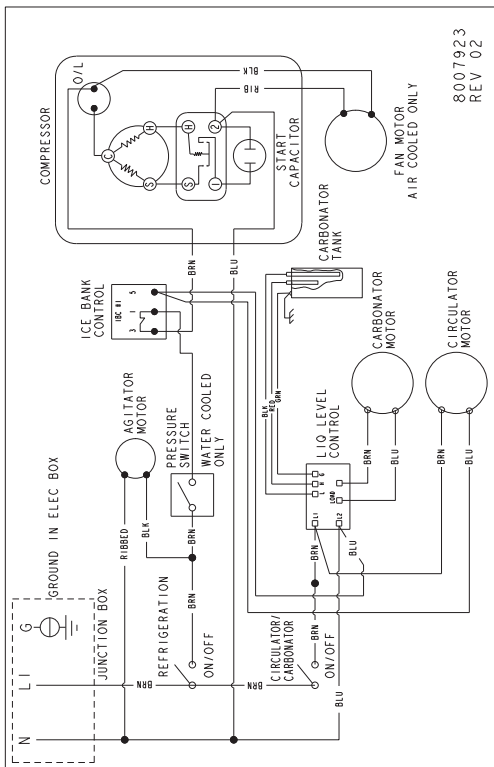

8007923
REV 02

MODEL 11

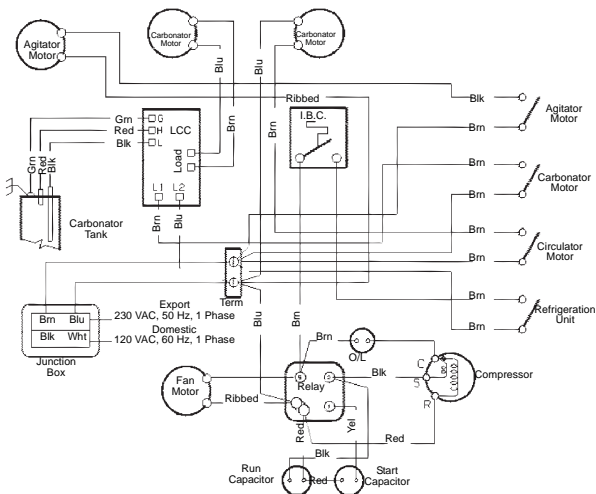

MODEL 11 ELECTRONIC IBC

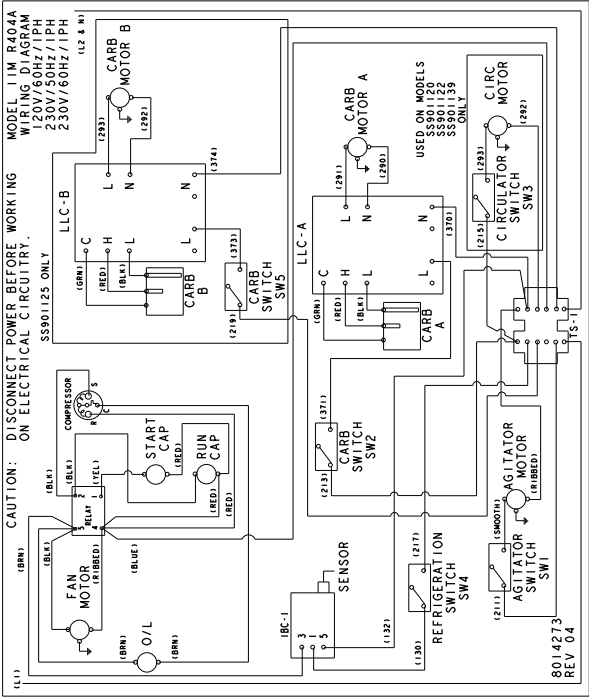

MODEL 42 & 44 ELECTRONIC IBC

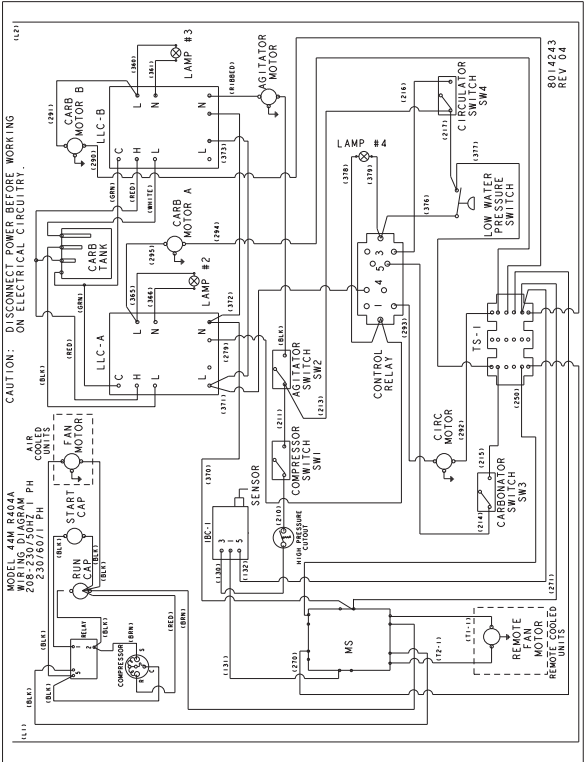

8014243
REV 04

MODEL 42 & 44 (WITH ERC 50 HZ)

50HZ

50HZ

CAUTION: DISCONNECT POWER BEFORE WORKING ON ELECTRICAL CIRCUITRY.

SEE SERIAL PLATE FOR VOLTAGE

SHOWN IN THE OFF POSITION

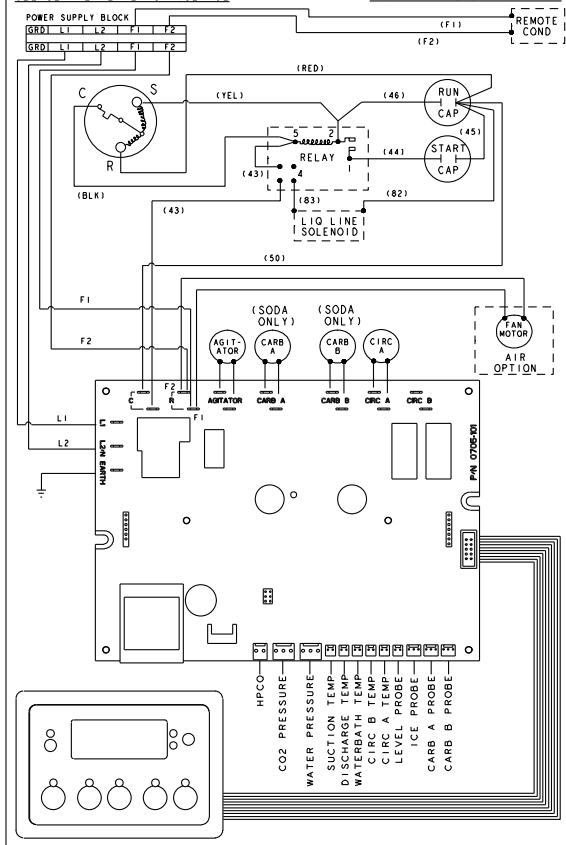

MODEL 42 & 44 (WITH ERC 60 HZ)

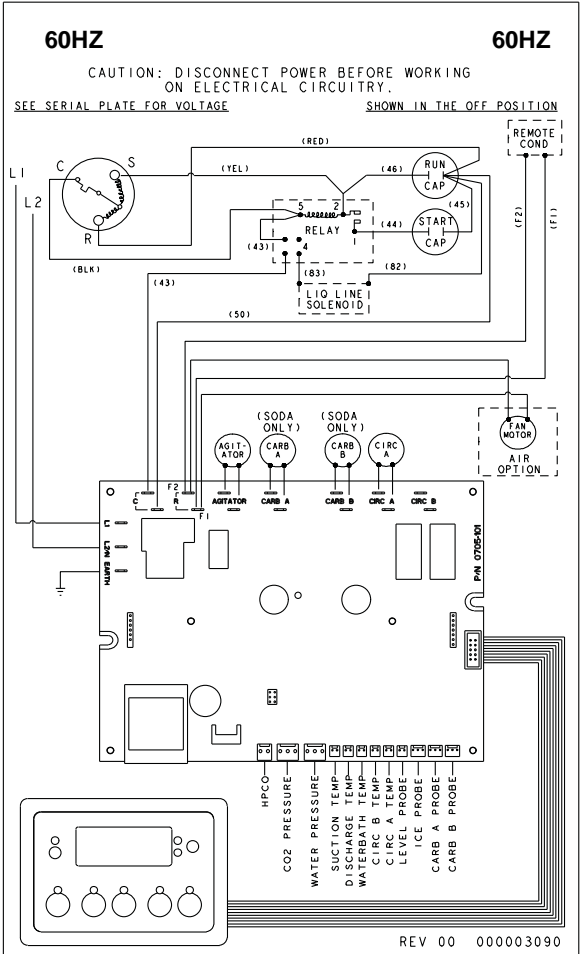

MODEL 44 (120V 60 HZ)

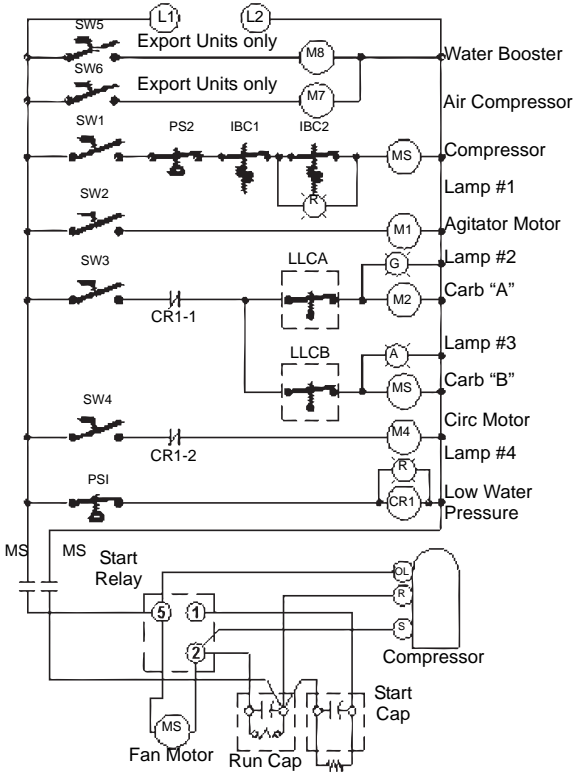

Component Legend	
MS	Relay Motor Start
SW	Switch ON/OFF
PS	Pressure Switch
CR	Control Relay
LLC	Liquid Level Control
IBC	Ice Bank Control
M	Motor
TS	Terminal Switch

MODEL 44 (230V 60 HZ)

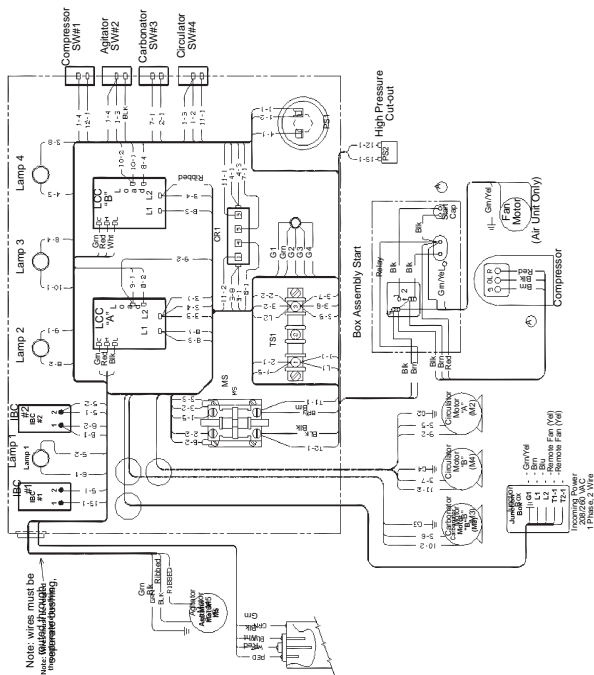

MODEL 50 (50 HZ)

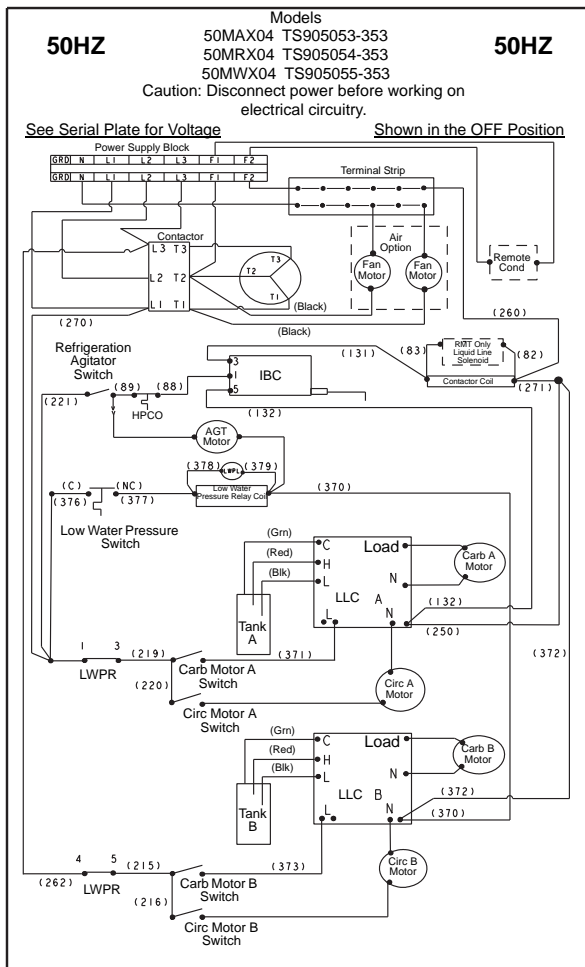

MODEL 50 (60 HZ)

60HZ

Models

- 50MA04 TS905050-363
- 50MR04 TS905051-363
- 50MW04 TS905052-363
- 50MR04Q/T TS905046-263

60HZ

Caution: Disconnect power before working on electrical circuitry.

See Serial Plate for Voltage

Shown in the OFF Position

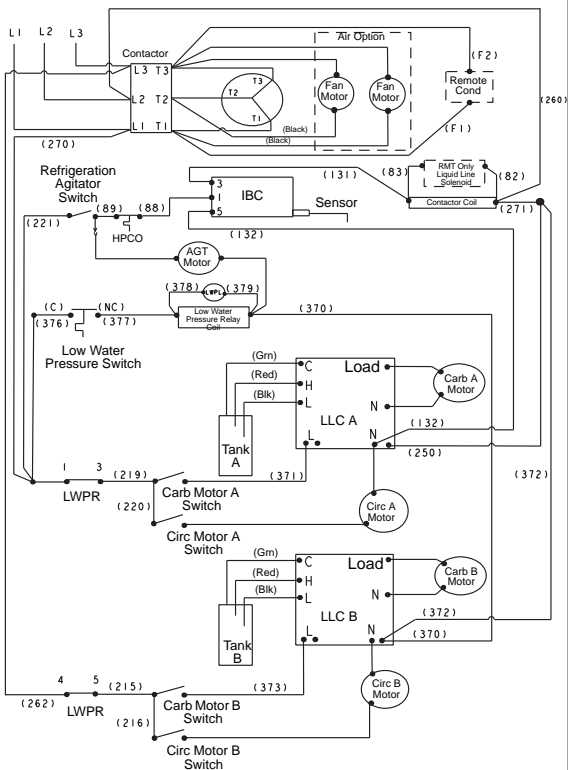

00000229.00

MODEL 50 (WITH ERC 50 HZ)

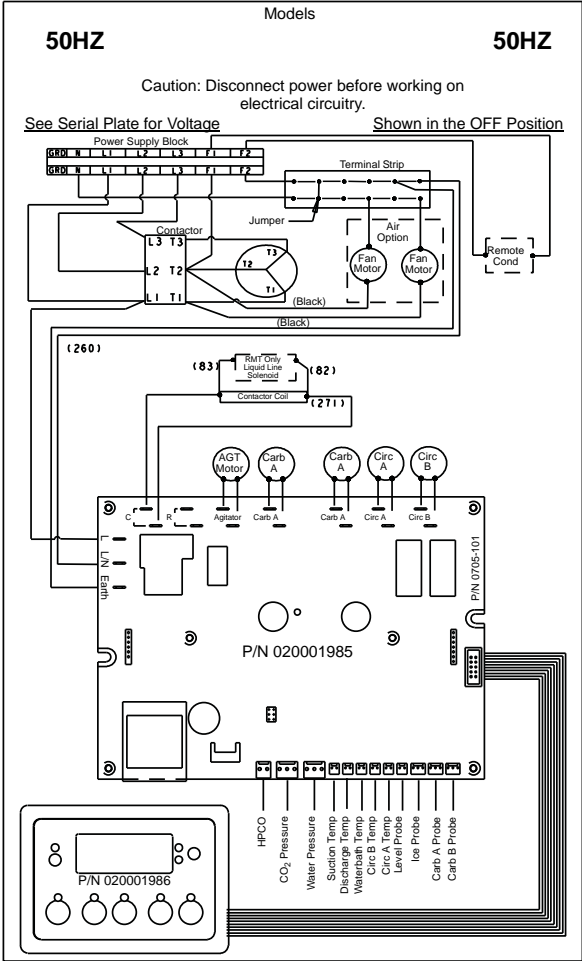

MODEL 50 (WITH ERC 60 HZ)

Models

60HZ

60HZ

Caution: Disconnect power before working on electrical circuitry.

See Serial Plate for Voltage

Shown in the OFF Position

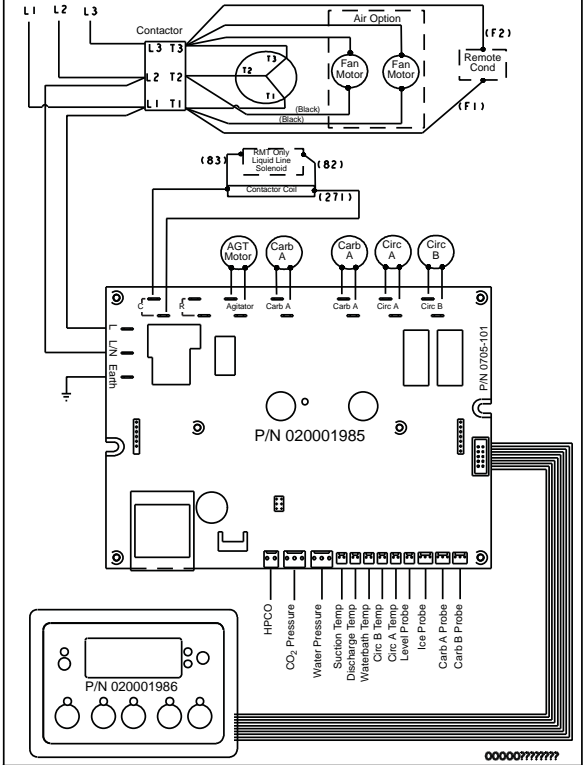

MODEL SC180 ELECTRONIC IBC

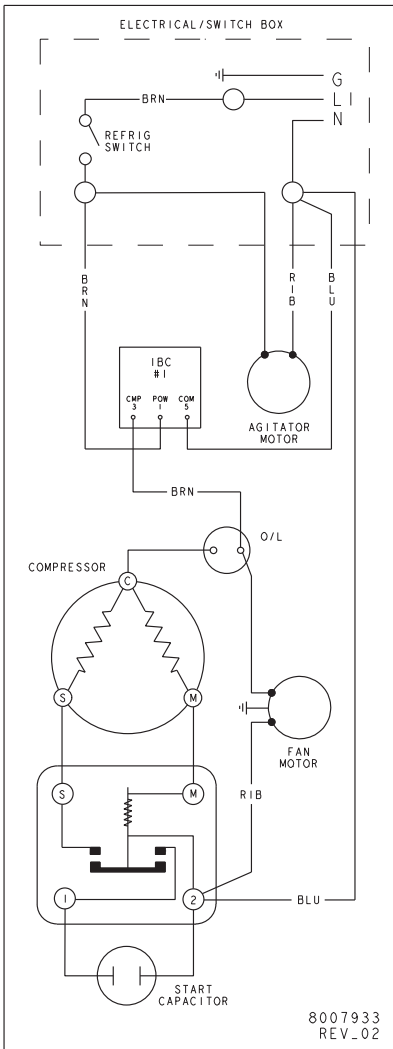

MODEL SC340 (120 VAC)

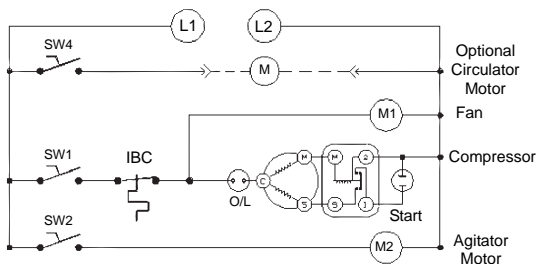

Component Legend

L1	Line 1
L2	Neutral
M	Motor
MS	Contactor
PS	Pressure Switch
IBC	Ice Bank Control

MODEL SC340 (120 VAC)

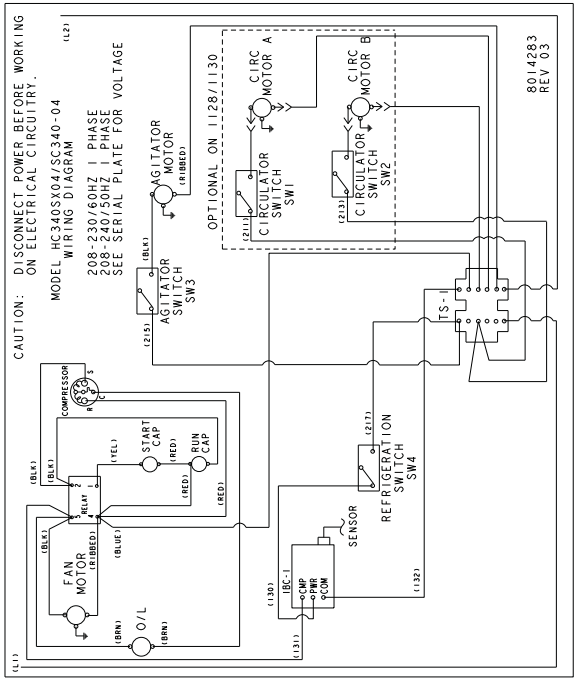

MODEL SC900 & SC1000

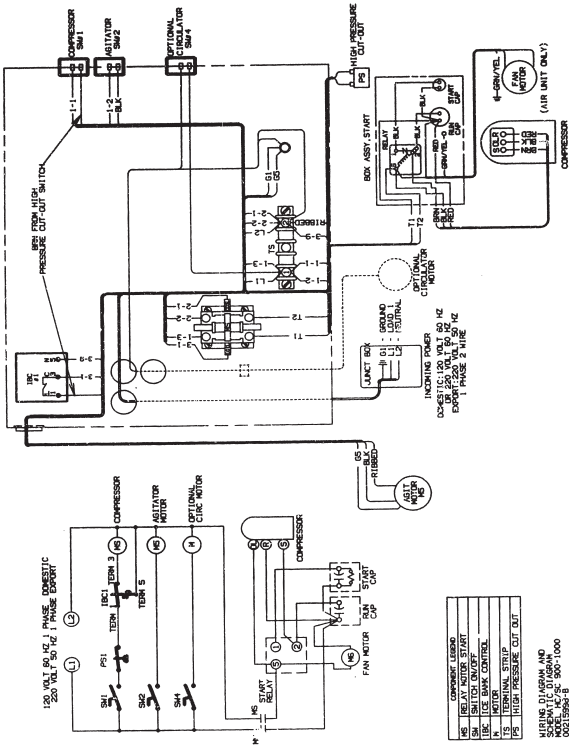

MODEL SC1000 (230 VAC)

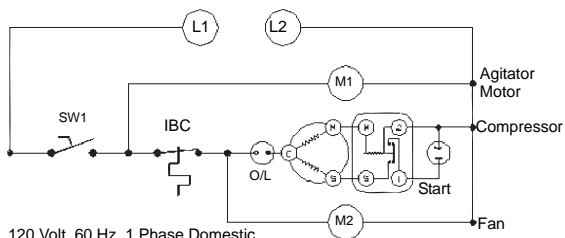

Component Legend

L1	Line 1
L2	Neutral
M	Motor
MS	Contactors
PS	Pressure Switch
IBC	Ice Bank Control

MODEL SC1000 ELECTRONIC IBC

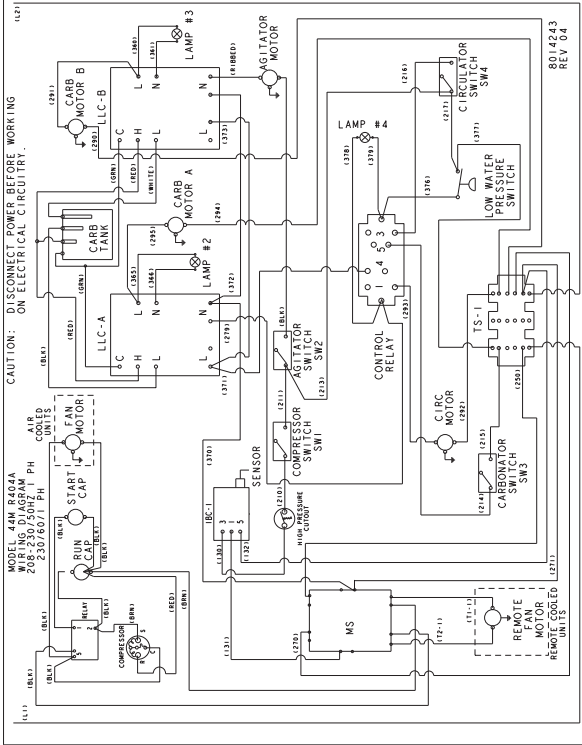

MODEL SC1000 (WITH ERC 60 HZ)

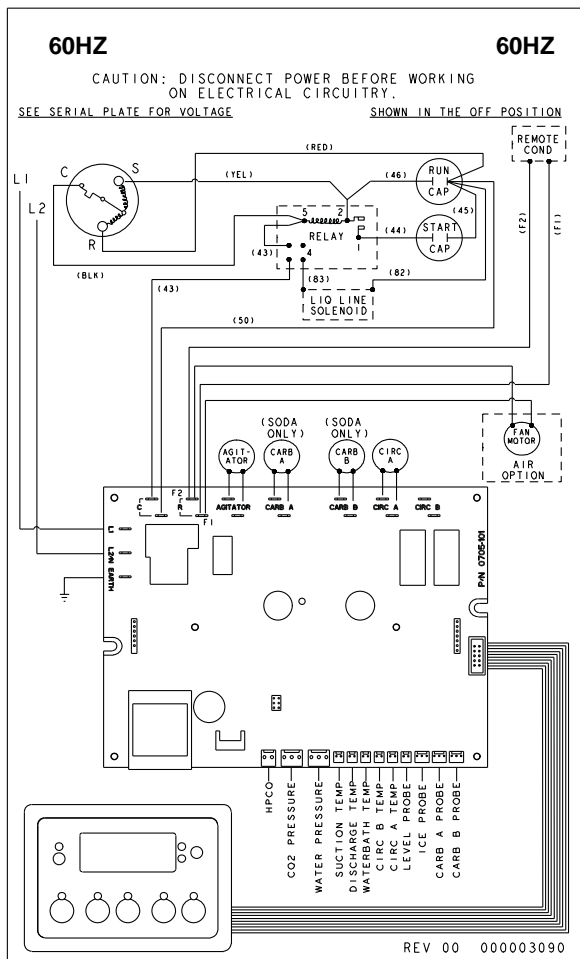

MODEL SC2000 (50 HZ)

50HZ

Models
 SC2000AX TS905063-353
 SC2000RX TS905064-353
 SC2000WX TS905065-353

50HZ

Caution: Disconnect power before working on electrical circuitry.

See Serial Plate for Voltage

Shown in the OFF Position

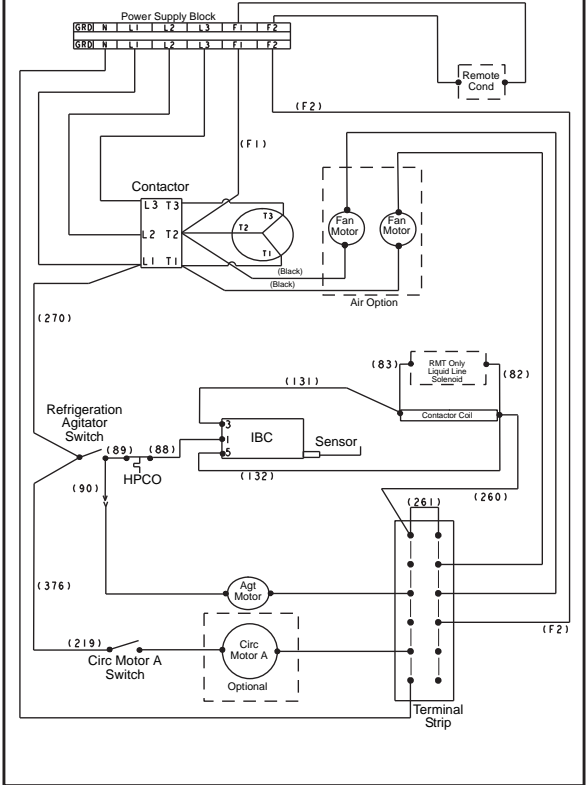

MODEL SC2000 (60 HZ)

60HZ

Models
 SC2000A TS905060-363
 SC2000R TS905061-363
 SC2000W TS905062-363

60HZ

Caution: Disconnect power before working on electrical circuitry.

See Serial Plate for Voltage

Shown in the OFF Position

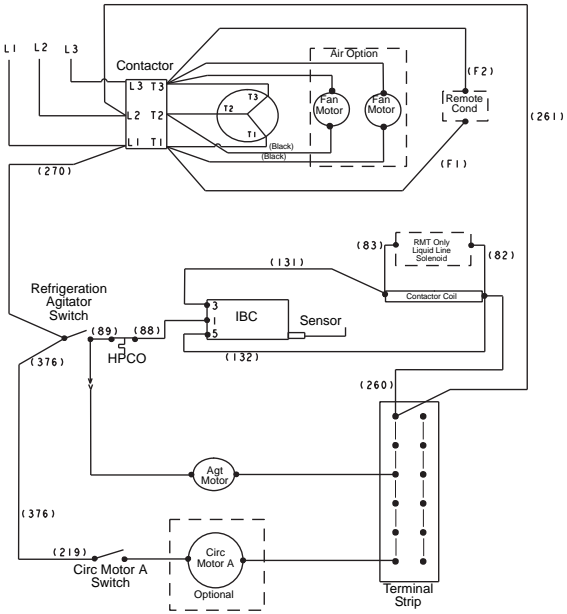

00000228.00

WIRING DIAGRAM FRONT DRAW TOWER

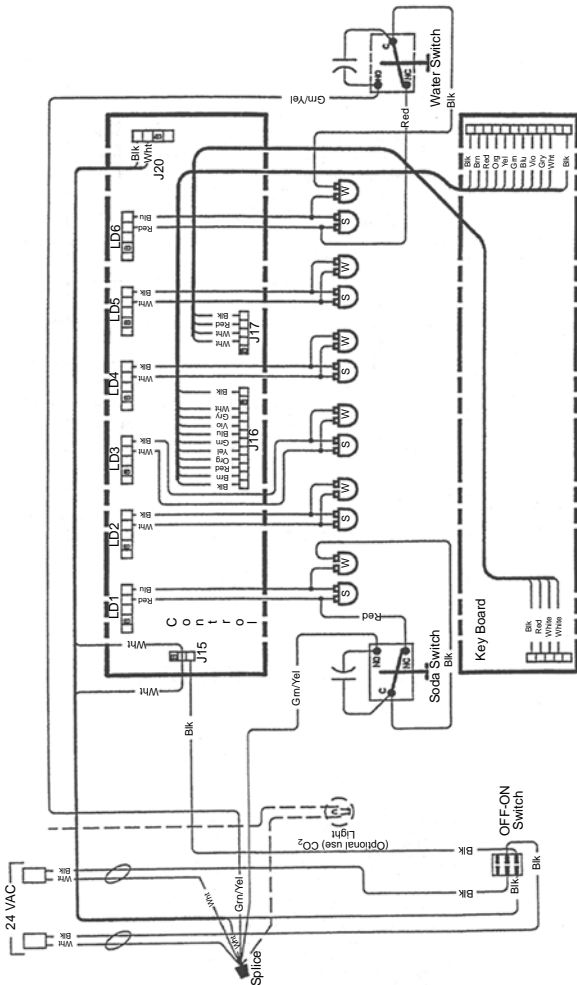

Circuit Schematics

PLUMBING CIRCUIT DIAGRAMS — MODEL 2803

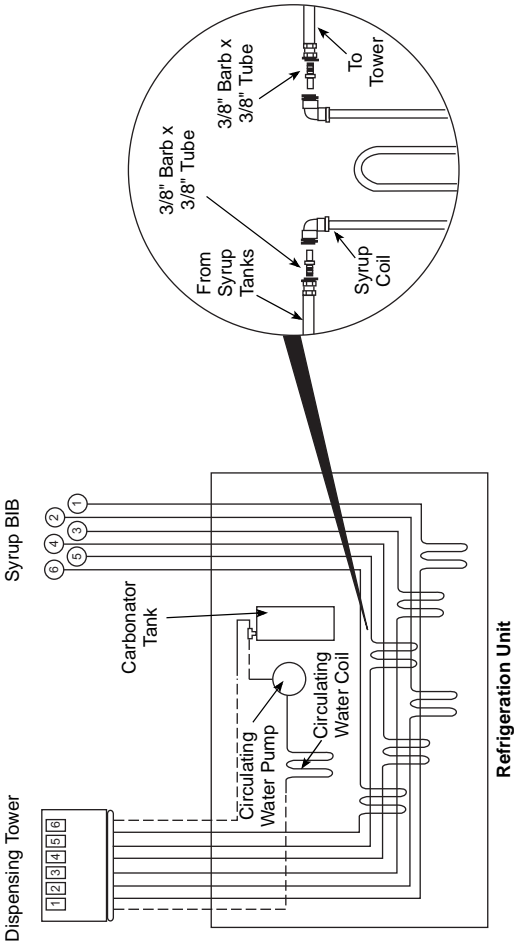

PLUMBING CIRCUIT DIAGRAMS — MODEL 11M ROOT BEER

Single Tower Plumbing

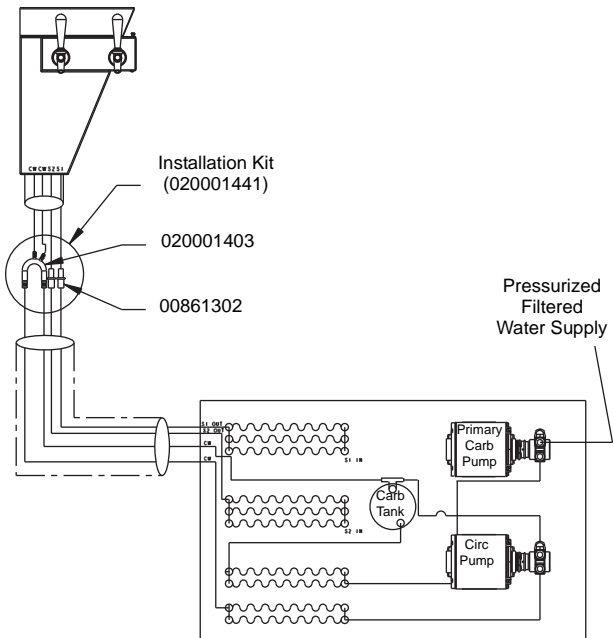

Model 11M Root Beer Dual Tower Plumbing

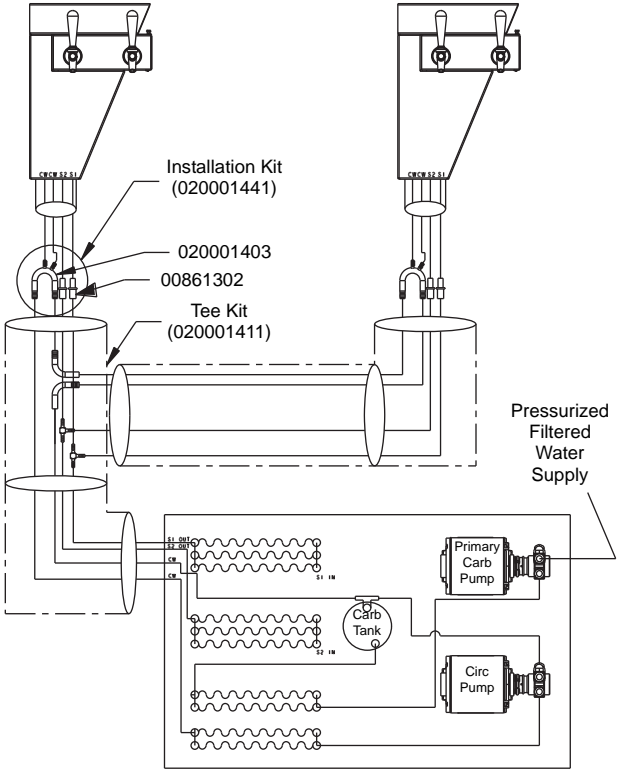

Model 11M Root Beer Three Tower Plumbing

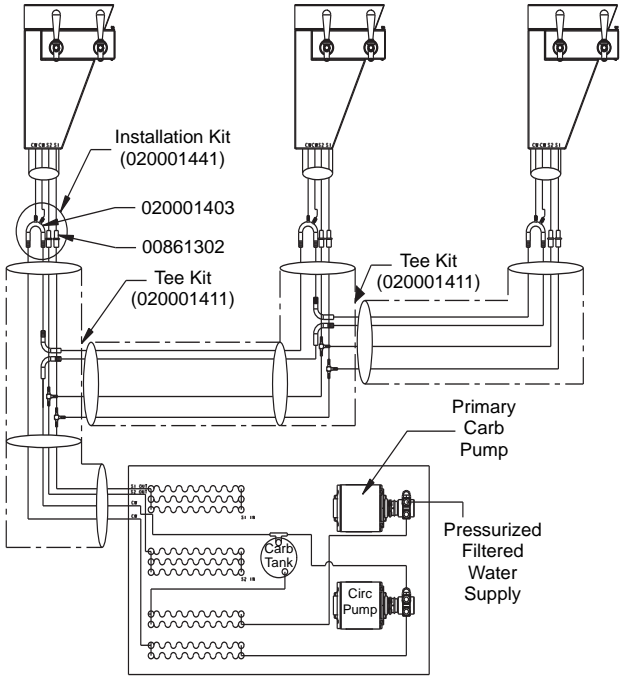

PLUMBING CIRCUIT DIAGRAMS — MODEL 44M

Pressurized Water Circuit Diagram

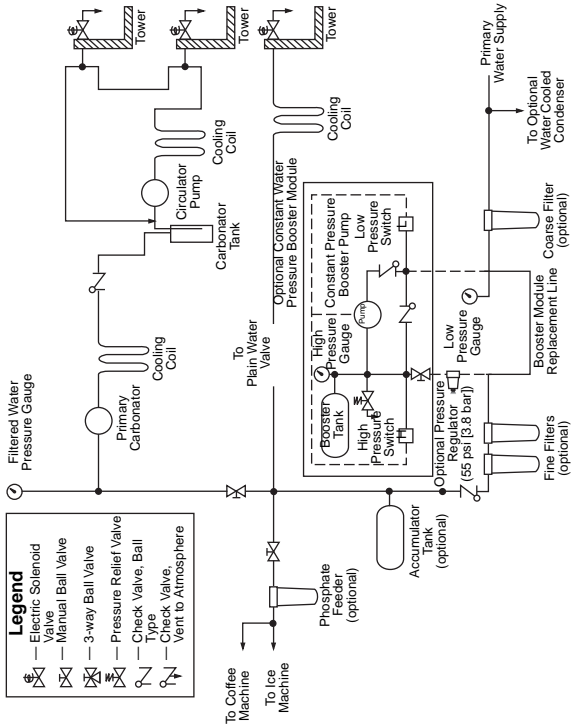

Pre-mix Plumbing — Six Valve Towers with Connection at Center Island

NOTE: Other plumbing configurations are possible. Check tower installation manual before making connections.

Single Tower System

Drive-thru or
Center Island Tower

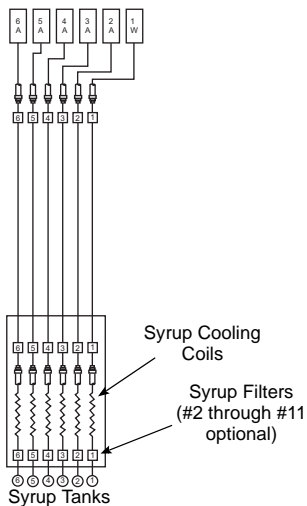

Two Tower System with Connection at Center Island

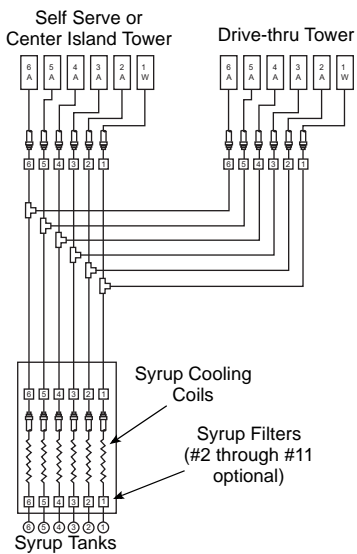

Three Tower System with Connection at Center Island

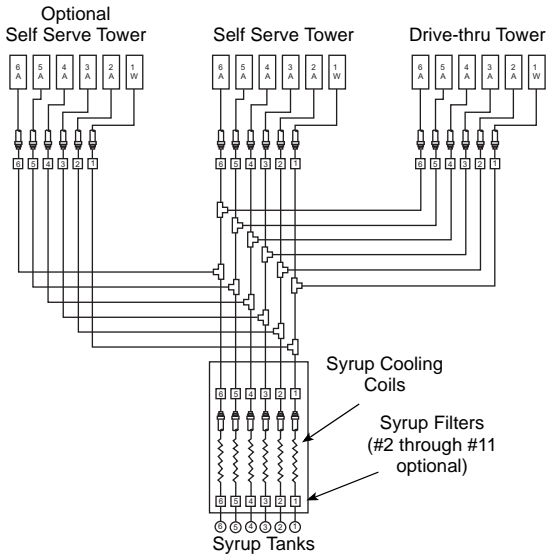

Pre-mix Plumbing — Eight Valve Towers with Connection at Center Island

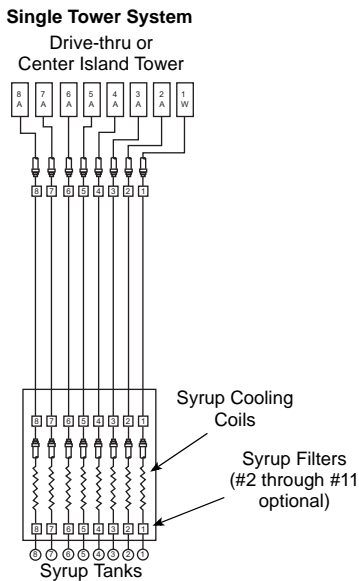

Two Tower System with Connection at Center Island

Self Serve or

Center Island Tower

Drive-thru Tower

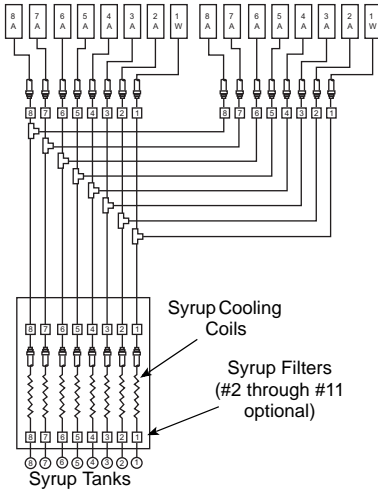

Three Tower System with Connection at Center Island

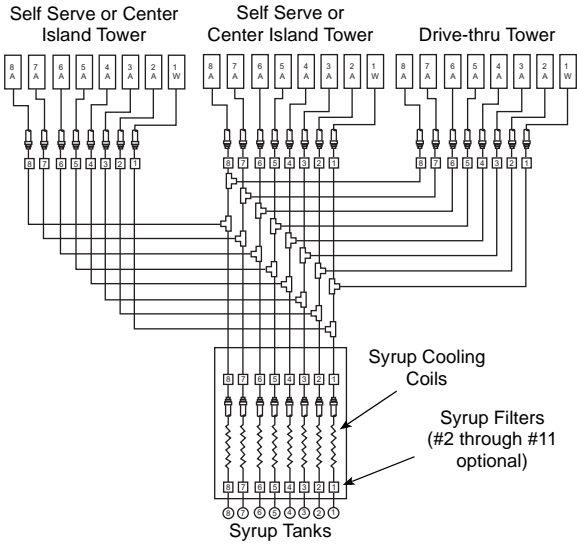

Carbonated Water Plumbing — Six Valve Towers with Connection at Unit

Supplies Carbonated Water to Diet Drink and Provides Conduit Cooling for Products

Single Tower System with Connection at Unit

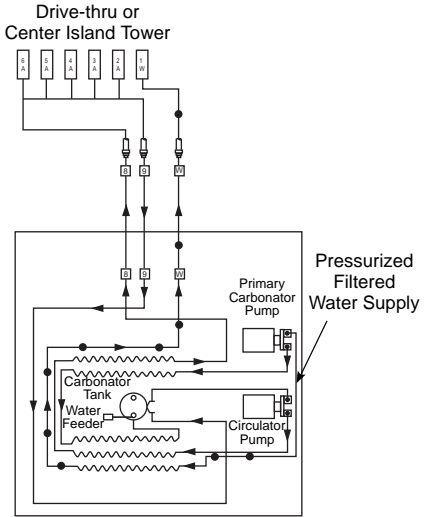

Two Tower System with Connection at Unit

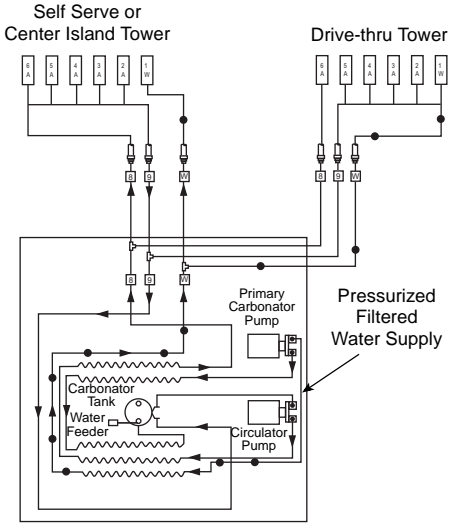

Three Tower System with Connection at Unit

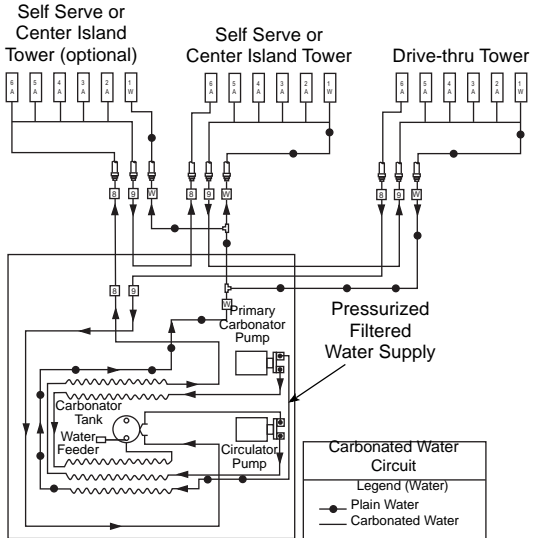

Carbonated Water Plumbing — Eight Valve Towers with Connection at Unit

Single Tower System with Connection at Unit

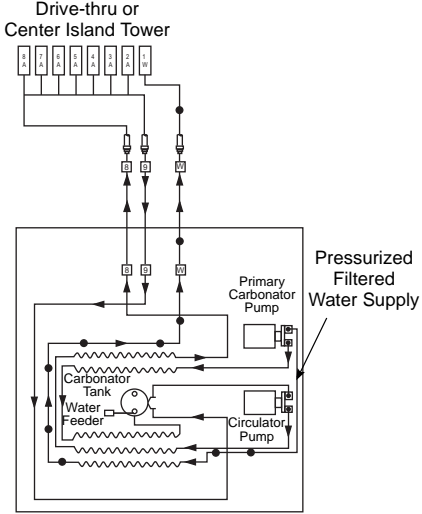

Two Tower System with Connection at Unit

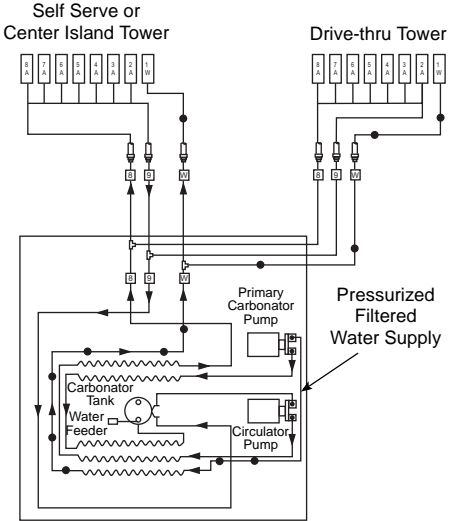

Three Tower System with Connection at Unit

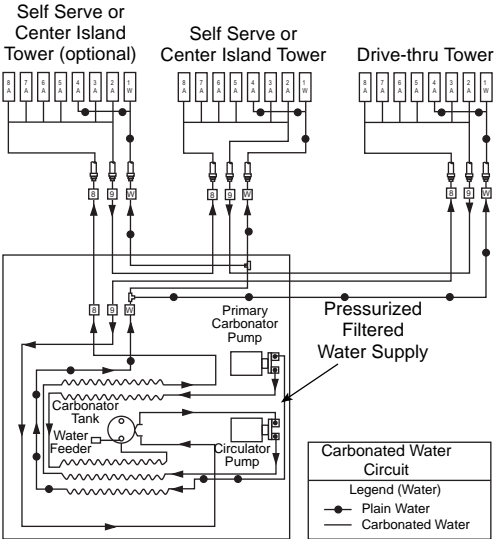

PLUMBING CIRCUIT DIAGRAMS — MODEL 50M

Pressurized Water Circuit Diagram

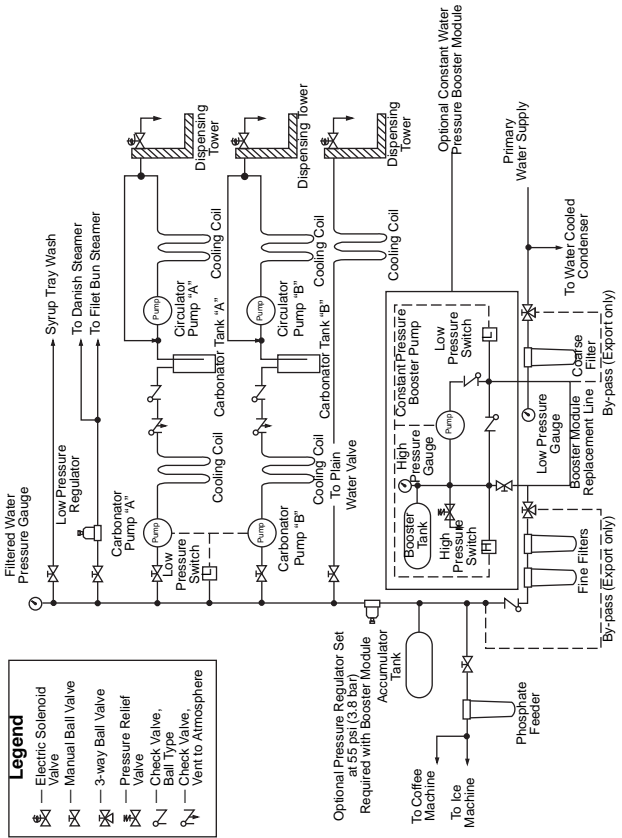

Ice/Beverage Units Diagrams

SERVEND RECOMMENDED PLUMBING

S-250M Plumbing Diagram

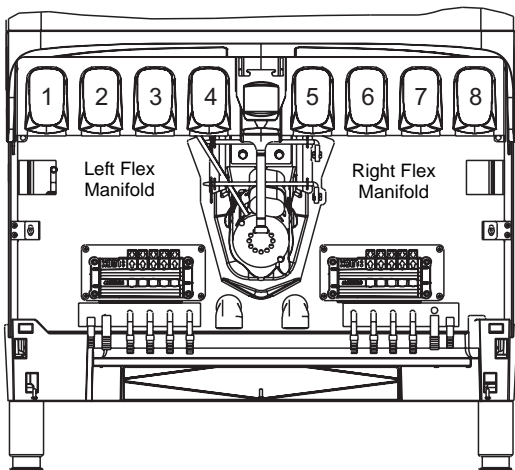

Manifold: Change to carbonated or non-carbonated water.

1. Rotate plunger 180° using a 5/32" Allen wrench.
2. Pull plunger out to get non-carbonated water.
3. Push plunger in to get carbonated water.
4. Turn plunger back 180° to lock.

MII-250 Plumbing Diagram

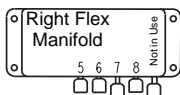
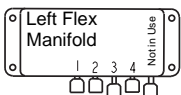
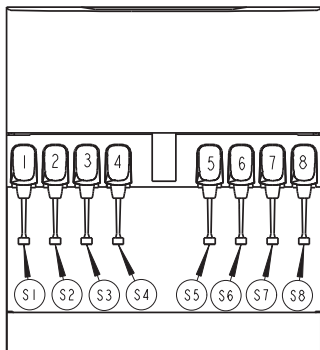

Manifold: Change to carbonated or non-carbonated water.

1. Rotate plunger 180° using a 5/32" Allen wrench.
2. Pull plunger out to get non-carbonated water.
3. Push plunger in to get carbonated water.
4. Turn plunger back 180° to lock.

MI-302 Plumbing Diagram

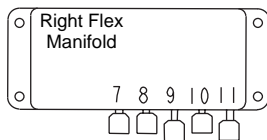
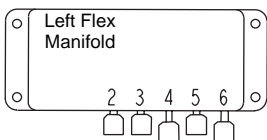
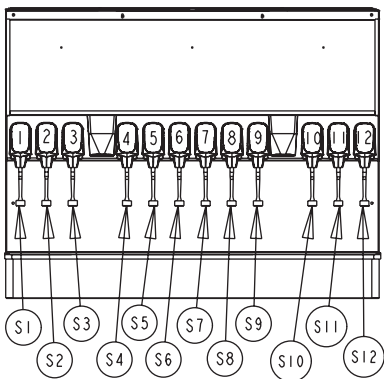

Manifold: Change to carbonated or non-carbonated water (S2-S11 only).

1. Rotate plunger 180° using a 5/32" Allen wrench.
2. Pull plunger out to get non-carbonated water.
3. Push plunger in to get carbonated water.
4. Turn plunger back 180° to lock.

For assistance call (812) 246-7000

This Page Intentionally Left Blank



Manitowoc Foodservice
2100 Future Drive
Sellersburg, IN 47172, USA
Ph: 812-246-7000 Fax: 812-246-7024
Visit us online at: www.manitowocfsg.com

© 2010 Maniowoc
Part Number STH12 9/10

