

MB MASTER-BILT[®]

Refrigeration Solutions



Installation & Operations Manual for

MB MASTER-BILT[®]

COLDIN-3™ SERIES

MSC-A & MSF-A Model
Display Freezers

PLEASE READ HANDBOOK BEFORE USING EQUIPMENT

TRANSPORTATION AND INSTALLATION

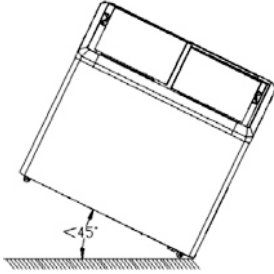

1. When transporting the freezer the angle between the compartment body and the ground should be no more than 45° and you should never place the freezer upside down.
2. Do not use any of the external parts as loading points, for example, the condenser on the back, the lids or the hinge.
3. When the freezer is installed or used, all the packaging (including carton and plastic wrap) should be removed.
4. Keep the freezer stable to avoid vibration and noise.
5. The freezer should be installed in a place with good ventilation and a space of at least 4" should be allowed between the surrounding walls and the cabinet wall for air circulation.
6. Unit should be placed far from any heating source and not in direct sunshine to avoid decrease of the efficiency of refrigeration.
7. Install the freezer in a dry place to prevent rust from forming on the compartment body, which may affect the electrical insulation.

CAUTION

1. The freezer must be grounded correctly, never with a heating pipe and coal gas pipe.
2. In case of damage on the electrical cord and plug, please contact after-sale service and never do it yourself. When pulling the plug out, please grasp by the plug, not the cord.
3. If the voltage is unstable, please select a suitable automatic voltage regulator.
4. Connect to the power to check the freezer before using, the freezer can be used until the temperature decreases obviously after 30 minutes.
5. You should adjust the temperature control according to the desired temperature, quantity of stored product and the ambient temperature.
6. Before loading product into the freezer please adjust the temperature control to the lowest point and allow unit to run until the temperature decreases to -18° . Then load product and after 12 hours adjust the temperature control to the normal point.
7. Never put hot food into the freezer directly, only after it has been cooled to room temperature.
8. Product should be loaded into the freezer in small quantities. Do not overfill the freezer or crowd it with product. Large packages of meat should be divided into several smaller packages. There should be reasonable space between the packages of product for better freezing.
9. If the power cuts off, you should wait for at least 5 minutes before turning on the unit again to avoid damage to the compressor.
10. Never store any flammable, explosive or corrosive liquid or gas in the freezer and keep the unit away from them.
11. Beer, beverage, fresh flowers, medications or injections must never be put into the freezer.
12. Please turn the temperature control to the lowest point if you want to store ice cream or similar frozen product.

STORAGE

The appliance is suitable for storing ice cream and ready-frozen foods.
It must not be filled higher than the stacking mark on the inside of the freezer.

LOAD LINE



LED Light



DEFROSTING

1. Defrost when the frost thickness on the cabinet wall reaches $\frac{1}{4}$ " to optimize the freezing capacity.
2. Turn the temperature control to the lowest point for 5-6 hours before defrosting.
3. Cut off the power and remove product, use the defrost removal tool that comes with the freezer, never use sharp tools.
4. After defrosting, clean the wall with dry cloth, and then power back on.

THE FOLLOWING CONDITIONS ARE NORMAL

1. There is a sound of flowing water when the refrigerant is running.
2. Frozen food will not melt even the power is off for a few hours.
3. When the ambient humidity is high, moisture can condense on the surface of the freezer.
4. When the unit is running the condenser and compressor will be hot.

COMPONENTS_MODELS MSC-31AN/MSC-41AN/MSC-49AN/MSC-66AN

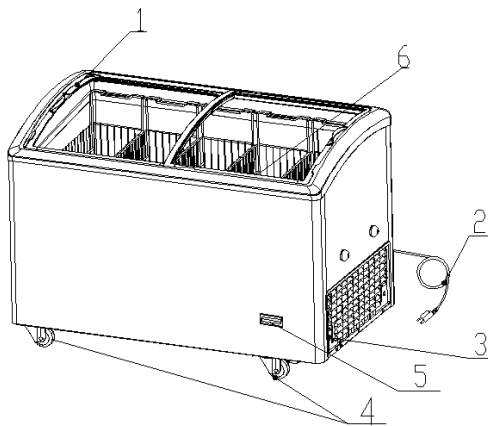

1. Sliding Upper Lid
2. Electrical Cord
3. Control Panel
4. Castors
5. Thermometer
6. LED Light

COMPONENTS_MODELS MSF-31AN/MSF-43AN/MSF-52AN/MSF-71AN

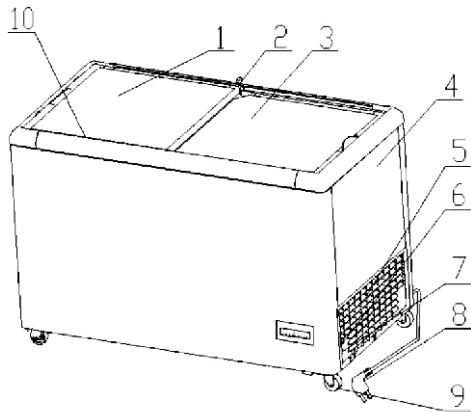

1. Upper Lid
2. Lock and keys
3. Lower Lid
4. Cabinet Exterior
5. Compressor Grill
6. Power Indicator Light
7. Thermostat
8. Cord
9. Castors
10. LED Light

CONTROL PANEL FUNCTIONS

1. The figure on the temperature control 1~7 only means the temperature level from high to low, not means the specific temperature.
2. The green light is a power indicator, when it is on , the power is connected.
3. We need to use a special tool (for example, a flat-blade screwdriver) to turn the axle till the nick pointing to a specific figure (1~7).
4. Turn the axle clockwise, the temperature inside will get cooler, turn the axle in the other direction, the temperature will get warmer.
5. When you turn the axle anticlockwise to "off" or "0",the compressor will stop working.
6. When the switch play to "-", it means the LED-Light is on.
7. We recommend the nick pointing to the 6 or 5,to ensure the food inside the cabinet is frozen effectively.

Do not turn the axle from "7" to "0" !

Do not turn the axle from "7" to "off" !

TROUBLE SHOOTING

TROUBLE	REASON	SOLUTION
Thawing	Temperature control is on the highest point	Adjust the temperature
	Plug and outlet not connected well	Make the two connect well
	Fuse broken off	Change the fuse
Compressor won't stop working	Temperature control is on the lowest point	Adjust temperature control
	Too much product stored at a time	Reduce the quantity being stored
	Thick frost	Defrost
	Lids opening too often	Reduce the times the lids are opened
	Too near the wall	Push away from the wall
Loud noise	Near heat source or sun	Change the location
	Ground is not flat	Change the location
	Refrigerating tubes connected	Separate them

NOTE If you can not solve the trouble according to the above mentioned ways, please contact after sale service, do not handle it yourself.

MAINTENANCE AND CLEANING

1. Do not open the door frequently and too long to save energy.
2. Never leave heavy or hot product on top of freezer to avoid warping.
3. Cut off the power before cleaning.
4. To clean the freezer please use soft cloth dampened in some moderate detergent and hot water.
5. Use warm water to clean oil or fruit juice stain on the magnetic gasket in order to keep its elasticity. Apply some talcum powder to it to prolong its service life.
6. The freezer should not be left unused for a long period of time. To discontinue freezer use, disconnect the main power first, then clean the inside and leave the door open for 2-3 days to dry completely.

ATTENTION

- The unit is not intended for use by children or the infirm without supervision.
- Young children should be supervised to ensure that they don't play with the freezer.
- We have a policy of continuous improvement on our products and reserve the right to change materials and specifications without notice. To confirm the specific parameters, please refer to the rated label on the product.

GLASS LID LOCKING INSTRUCTIONS FOR MODELS MSC-31AN/MSC-41AN/MSC-49AN/MSC-66AN & MSF-31AN/MSF-43AN/MSF-52AN/MSF-71AN

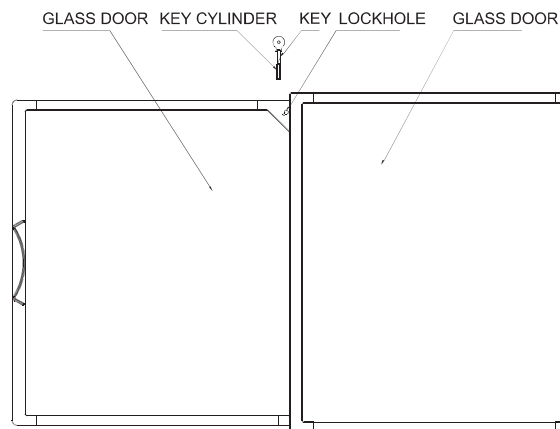

1. Unlocking the freezer: Insert key into the lockhole of the key cylinder. Then rotate the key 90°clockwise and remove the key and key cylinder. Sliding doors are unlocked.
2. Locking the freezer: Insert key and key cylinder into lockhole and rotate 90°counter-clockwise. Then remove the key while leaving the key cylinder in the lockhole. This prevents the sliding doors from moving and the lids are locked into place.

DIRECTIONS FOR WATER COLLECTION TRAY

1. Before using the unit, open the plastic accessory bag inside the freezer and remove the white plastic water collection tray.
2. Hold the tray by its handle and insert it into the guide rails on the outer bottom of the freezer from the front surface of the freezer.
3. Slide out to empty the accumulated water and re-insert by repeating the above two steps.

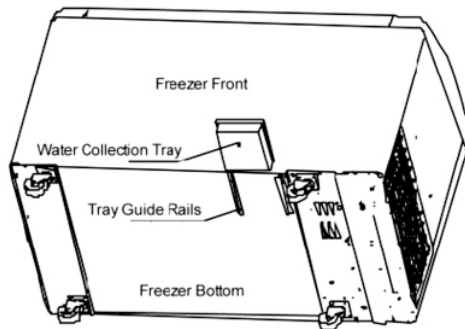



Customer Service/Warranty Parts

Phone: 800-684-8988

Fax: 866-882-7629

Email: rsgservice@refsg.com