

Model C602

Combination Shake / Soft Serve Freezer

Service Manual

057888-S



4/6/04

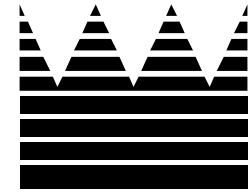

Table of Contents

Section 1: Introduction	1
Safety	2
Refrigerant	2
Model C602 Specifications	4
Installation Instructions	5
Section 2: Systems, Controls and Operations	7
Running Specifications	8
Refrigeration System Schematic	9
Control Panel Functions	10
Freezer Lock-Out	14
Heat Treatment Cycle	33
Heat Treatment Graph	34
Timers	35
Glycol System	37
Glycol Path	39
Setting Viscosity	40
Portion Control (Shake)	41
Adjustable Draw Handle	42
Control Overview	43
Universal Control (UVC3)	44
Electrical System Modes of Operation Chart	47
Electrical System - L1 Power Path	48
Shake Draw Sequence Chart	50
Syrup Delivery	51
Syrup Calibration	52
Shake Dispensing Alignment Procedure	54

Section 3: Troubleshooting	57
General Troubleshooting Guide	58
Air Mix Pump System Troubleshooting	63
Peristaltic Syrup System Troubleshooting Guide	64
Shake Dispensing Mechanism Troubleshooting	67
Shake Portion Control Troubleshooting	69
Bacteria Troubleshooting	70
Section 4: Parts	73
Warranty Explanation	74
Main Exploded View	76
Syrup Cabinet View	79
Mix Pump & Tubes	80
Pump A. - Mix Simplified Shake - X57028-XX	81
Pump A. - Mix Simplified Soft Serve - X57029-XX	82
Brush Identification	83
Control Assembly - X55966-33	84
Dec Plate Assembly - X55963	86
Torque Coupling Assembly - X54722	87
Glycol Heater Assembly - X55965-27	88
Sensor Holder Assembly - X55980	89
Parts List	90
Wiring Diagrams	110

CAUTION: Information in this manual is intended to be used by Taylor Authorized Service Technicians only.

Note: Continuing research results in steady improvements; therefore, information in this manual is subject to change without notice.

© April, 2004 Taylor
All rights reserved.
057888-S

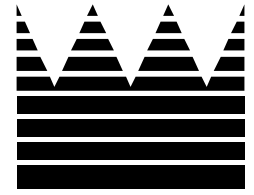

Section 1: Introduction

- **Safety**
- **Refrigerant**
- **Specifications**
- **Installation Instructions**

Safety

We at Taylor Company, are committed to manufacturing safe operating and serviceable equipment. The many built-in safety features that are part of all Taylor equipment are aimed at protecting operators and trained service technicians alike.

This manual is intended exclusively for Taylor Company authorized service personnel.



Stationary appliances which are not equipped with a power cord and a plug or other device to disconnect the appliance from the power source must have an all-pole disconnecting device with a contact gap of at least 3 mm installed in the external installation.



This machine must be placed on a level surface. Failure to comply may result in personal injury or equipment damage.



DO NOT install the machine in an area where a water jet could be used to clean or rinse the freezer. Failure to follow this instruction may result in serious electrical shock.



DO NOT remove the door, beater, scraper blades, drive shaft or air/mix pump unless all control switches are in the OFF position. Failure to follow this instruction may result in severe personal injury from hazardous moving parts.

This machine is designed to operate indoors, under normal ambient temperatures of 70°-75°F (21°-24°C). The machine has successfully performed in high ambient temperatures of 104°F (40°C) at reduced capacities.

NOISE LEVEL: Airborne noise emission does not exceed 78 dB(A) when measured at a distance of 1.0 meter from the surface of the machine and at a height of 1.6 meters from the floor.

Refrigerant

Taylor Company uses R404A refrigerant. This refrigerant is generally considered non-toxic and non-flammable; however, any gas under pressure is potentially hazardous.



NEVER fill any refrigerant cylinder completely with liquid. Filling the cylinder to approximately 80% will allow for normal expansion.



Refrigerant liquid sprayed onto the skin may cause serious damage to tissue. Keep eyes and skin protected. If refrigerant burns should occur, flush immediately with cold water. If burns are severe, apply ice packs and contact a physician immediately.

The Taylor Company reminds technicians to be cautious of government laws regarding refrigerant recovery, recycling, and reclaiming systems. If you have any questions regarding these laws, please contact the factory Service Department.

WARNING: R404A refrigerant used in conjunction with polyolester oils is extremely moisture absorbent. When opening a refrigeration system, the maximum time the system is open must not exceed 15 minutes. Cap all open tubing to prevent humid air or water from being absorbed by the oil.

Compressor Warranty Disclaimer

The refrigeration compressor(s) on this machine are warranted for the term indicated on the warranty card accompanying this machine. However, due to the Montreal Protocol and the U.S. Clean Air Act Amendments of 1990, many new refrigerants are being tested and developed; thus seeking their way into the service industry. Some of these new refrigerants are being advertised as drop-in replacements for numerous applications. It should be noted that, in the event of ordinary service to this machine's refrigeration system, only the refrigerant specified on the affixed data label should be used. The unauthorized use of alternate refrigerants will void your compressor warranty. It will be the owners' responsibility to make this fact known to any technicians they employ.

It should be noted, that Taylor does not warrant the refrigerant used in its equipment. For example, if the refrigerant is lost during the course of ordinary service to this machine, Taylor has no obligation to either supply or provide its replacement either at billable or unbillable terms. Taylor does have the obligation to recommend a suitable replacement if the original refrigerant is banned, obsoleted, or no longer available during the five year warranty of the compressor.

The Taylor Company will continue to monitor the industry and test new alternates as they are being developed. Should a new alternate prove, through our testing, that it would be accepted as a drop-in replacement, then the above disclaimer would become null and void. To find out the current status of an alternate refrigerant as it relates to your compressor, call the local Taylor Distributor or the Taylor Factory. Be prepared to provide the model/serial number of the unit in question.

Model C602 Specifications

Freezing Cylinders

Shake Side: One, 7 quart (6.6 liter)
 Soft Serve: One, 3.4 quart (3.2 liter)

Mix Hopper

Two, 20 quart (18.9 liter). Refrigerated to maintain mix below 41°F (5°C).

Beater Motor

Shake: 1.0 HP
 Soft Serve: 1.5 HP

Refrigeration System

Shake: 11,000 BTU/hr
 Soft Serve: 9,500 BTU/hr
 Refrigerant: R404A (BTU's may vary depending on compressor used.)

Main Compressor:

Air Cooled Units:
 Shake: 54 oz (1,531 g) of R404A
 Soft Serve: 46 oz (1,304 g) of R404A

Water Cooled Units:
 Shake: 48 oz (1,361 g) of R404A
 Soft Serve: 32 oz (907 g) of R404A

Note: Specifications are subject to change. Check the data label for proper charging specifications.

Electrical

Standard is 208/230-60-3; however, other electrical characteristics are available. Each unit requires electrical service - Three Phase Maximum Fuse Size: 40 A, Minimum Wire Ampacity: 36 A

Note: McDonald's specifies Hubbell A460P9 plug for 208-230/60-3 equipment.

Air Cooled

Clearance: A minimum of 3" (76 mm) is required around all sides. Install the deflector provided to prevent recirculation of warm air. Minimum air clearances must be met to assure adequate air flow for optimum performance.

Dimensions

Width: 25-1/4" (641 mm) including cup/cone dispenser: 32-3/8" (822 mm)
 Height: 60-7/16" (1535 mm)
 Depth: 38-7/8" (987 mm)
 Floor Clearance: 4-3/4" (121 mm)

Approximate Weights

Net: 815 lbs. (369.7 kgs)
 Crated: 1046 lbs. (474.5 kgs)
 Volume: 66.5 cu ft (1.88 cu m)

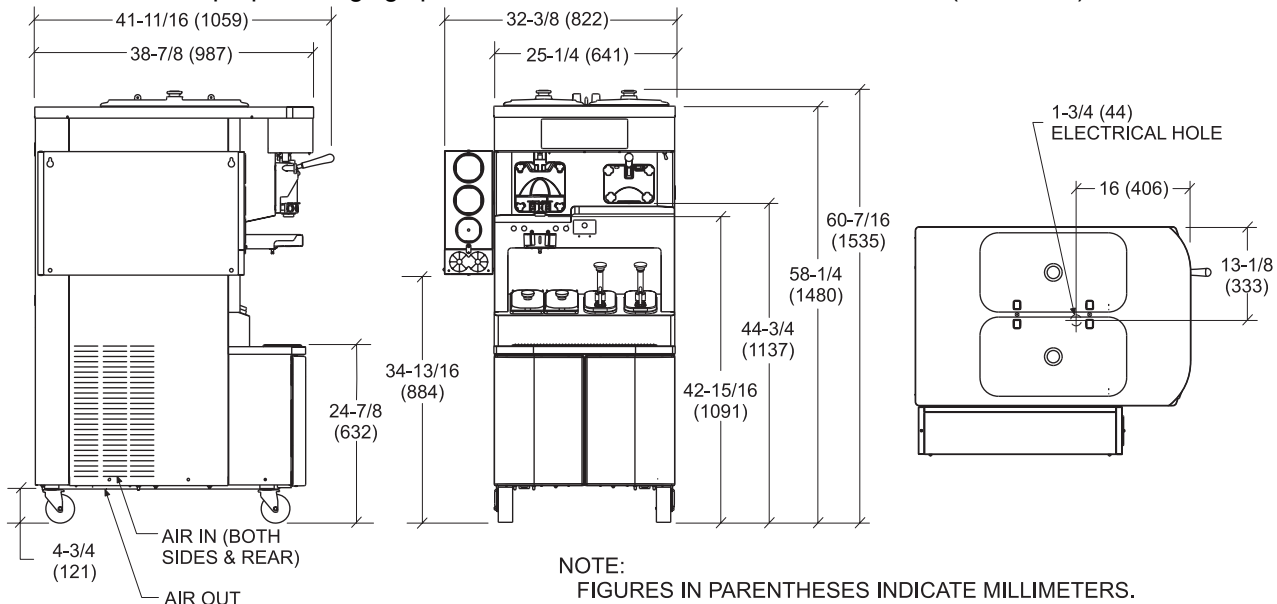

TOP VIEW - OPERATOR END
 ALL CONNECTIONS LOCATED UNDERSIDE OF BASE

Figure 1

Installation Instructions



This machine must be placed on a level surface. Failure to comply may result in personal injury or equipment damage.



DO NOT install the machine in an area where a water jet could be used to clean or rinse the freezer. Failure to follow this instruction may result in serious electrical shock.

Disconnect Switch



Stationary appliances which are not equipped with a power cord and a plug or other device to disconnect the appliance from the power source must have an all-pole disconnecting device with a contact gap of at least 3 mm installed in the external installation.

Air Cooled Units

These units require a minimum of 3" (76 mm) of air clearance around all sides. Install the deflector provided to prevent recirculation of warm air. Minimum air clearances must be met to assure adequate air flow for optimum performance.

Gear Alignment and Rear Shell Bearing

1. Make certain the drive shaft can easily slide in and out of the female socket on the gear unit.
2. If a drive shaft is binding, the gear unit could be out of alignment (loose). Check the bolts on the gear unit to be sure they are tight.
3. Inspect the rear shell bearing for tightness. Be sure the locking tab has been folded over to prevent the nut from loosening.

Note: If the gear unit is out of alignment, refer to the General Service Manual.

Beater Rotation



REMEMBER TO DISCONNECT ALL POWER TO THE FREEZER! Failure to follow this instruction may result in electrocution.

Beater rotation = CLOCKWISE (when viewed from the front of the machine).

Note: This machine is equipped with an interlock circuit that prevents beater motor operation when the freezer door is not installed.

1. Remove the side panels.
2. Place the power switch in the ON position.
3. Select the WASH key on the control panel. This activates the beater motor only.



CAUTION: Hazardous moving components! Keep your hands clear when operating the machine with the panels removed. Failure to follow this instruction may result in severe personal injury from hazardous moving parts.

4. Check the rotation of the drive coupling located on the output shaft of the gear reducer. The coupling should be turning CLOCKWISE as viewed from the front of the machine.
5. Press the WASH key again to stop the beater motor.

If rotation is not correct, exchange any two incoming power lines at the freezer main terminal box only (splice box).



REMEMBER TO DISCONNECT ALL POWER TO THE FREEZER! Failure to follow this instruction may result in electrocution.

Pump Motor Rotation

1. Remove the air/mix pump assembly.
2. Connect power to the freezer and place the power switch in the ON position.
3. Press the PUMP key on the control panel. This will activate the pump motor only.
4. Observe the pump ball crank. It should be rotating counterclockwise.

If rotation is not correct, refer to the wiring diagram on the pump motor and re-wire accordingly.



REMEMBER TO DISCONNECT ALL POWER TO THE FREEZER! Failure to follow this instruction may result in electrocution.

Electrical Connections

Each freezer requires one power supply. Check the data label on the freezer for fuse, circuit ampacity and electrical specifications. Refer to the wiring diagram, provided inside the control box, for proper power connections.

In the United States, this equipment is intended to be installed in accordance with the National Electrical Code (NEC), ANSI/NFPA 70-1987. The purpose of the NEC code is the practical safeguarding of persons and property from hazards arising from the use of electricity. This code contains provisions considered necessary for safety. Compliance therewith and proper maintenance will result in an installation essentially free from hazard!

In all other areas of the world, equipment should be installed in accordance with the existing local codes. Please contact your local authorities.

Stationary appliances which are not equipped with a power cord and a plug or other device to disconnect the appliance from the power source must have an all-pole disconnecting device with a contact gap of at least 3 mm installed in the external installation.

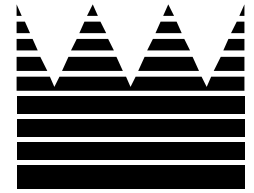

Section 2:

Systems, Controls and Operations

- **Running Specifications**
- **Refrigeration System Schematic**
- **Control Panel Functions**
- **Freezer Lock-Out**
- **Heat Treatment Cycle**
- **Heat Treatment Graph**
- **Timers**
- **Adjustable Draw Handle**
- **Beater Stir Cycles**
- **Glycol System**
- **Glycol Path**
- **Setting Viscosity**
- **Portion Control (Shake)**
- **Control Overview**
- **Electrical System Modes of Operation Chart**
- **Electrical System - L1 Power Path**
- **Shake Draw Sequence Chart**
- **Syrup Delivery**
- **Syrup Calibration**
- **Shake Draw Mechanism Alignment**

Running Specifications

Pressures/Temperatures

The following are the Taylor Company recommended settings for various components in the Model C602. (See page 9 for the Refrigeration System Schematic.)

Expansion Valve

Soft Serve

Air Cooled: 20 - 22 psi. (138 - 152 kPa)
 Water Cooled: 20 - 22 psi. (138 - 152 kPa)
 for a normal product of 16° - 18°F. (-8.8° to -7.7°C).

Shake

Air Cooled: 38 - 39 psi. (262 - 269 kPa)
 Water Cooled: 38 - 39 psi. (262 - 269 kPa)
 for a normal product of 24° - 26°F. (-4°C).

Note: Triple Thick Shake product temperature is 22° - 24°F. (-5°C).

Expansion Valve Adjustment

Connect your refrigerant gauge to the low side access valve. Turn the access valve counter-clockwise to open the valve.

Adjust the pressure higher or lower by turning the expansion valve adjustment screw. Clockwise turns will raise the pressure and counterclockwise will lower the pressure.

Note: Make expansion valve adjustments with mix in the freezing cylinder and the freezer in the AUTO mode. Be sure to allow adequate time for the pressure to stabilize.

Turn the access valve clockwise to close the valve. Install and securely tighten the access valve caps and the expansion valve cap.

Low Side (Suction)

Suction pressure equals expansion valve setting.

High Side (Discharge)

High side pressure varies for air cooled units, depending on the ambient temperature.

Ambient Temperature		Normal Operating Head Pressures
F	C	PSI
70°	21.1°	240 - 270 (1,655 - 1,862 kPa)
80°	26.7°	270 - 300 (1,862 - 2,069 kPa)
90°	32.2°	300 - 340 (2,069 - 2,344 kPa)
100°	37.8°	340 - 380 (2,344 - 2,620 kPa)

Water Valve

On a water cooled unit, the water valve should be set to maintain a compressor head pressure of 255 psi. (1,758 kPa).

Water Valve Adjustment

Note: Make this adjustment with mix in the cylinder and the freezer in the AUTO mode. Be sure to allow adequate time for pressure to stabilize.

Connect your refrigerant gauge to the high side access valve. Turn the access valve counter-clockwise to open the valve. Turning the adjustment stem on the water valve clockwise will lower the pressure.

Turn the access valve clockwise to close the valve. Install and securely tighten the access valve caps.

Refrigeration System Schematic

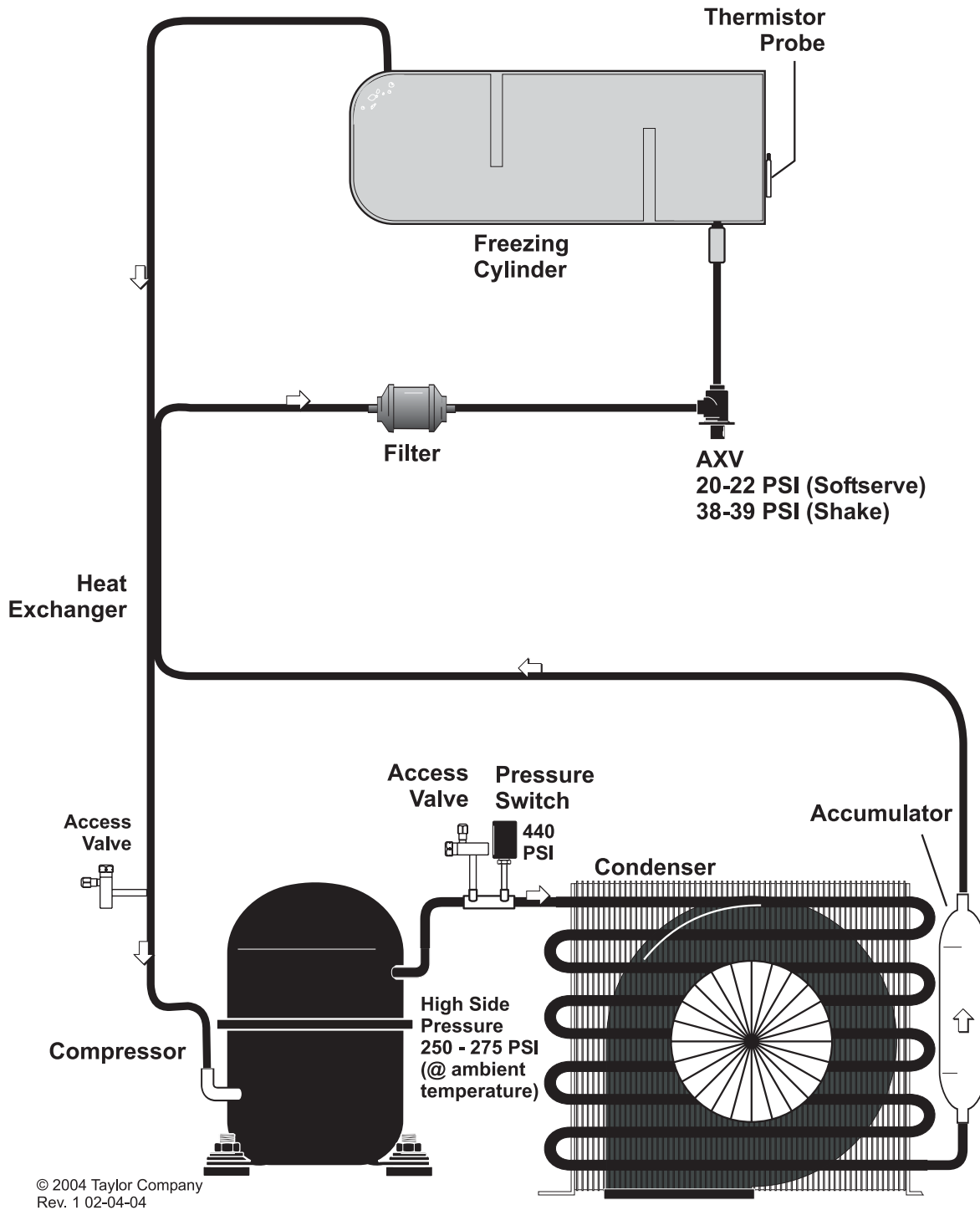

Figure 2

Control Panel Functions

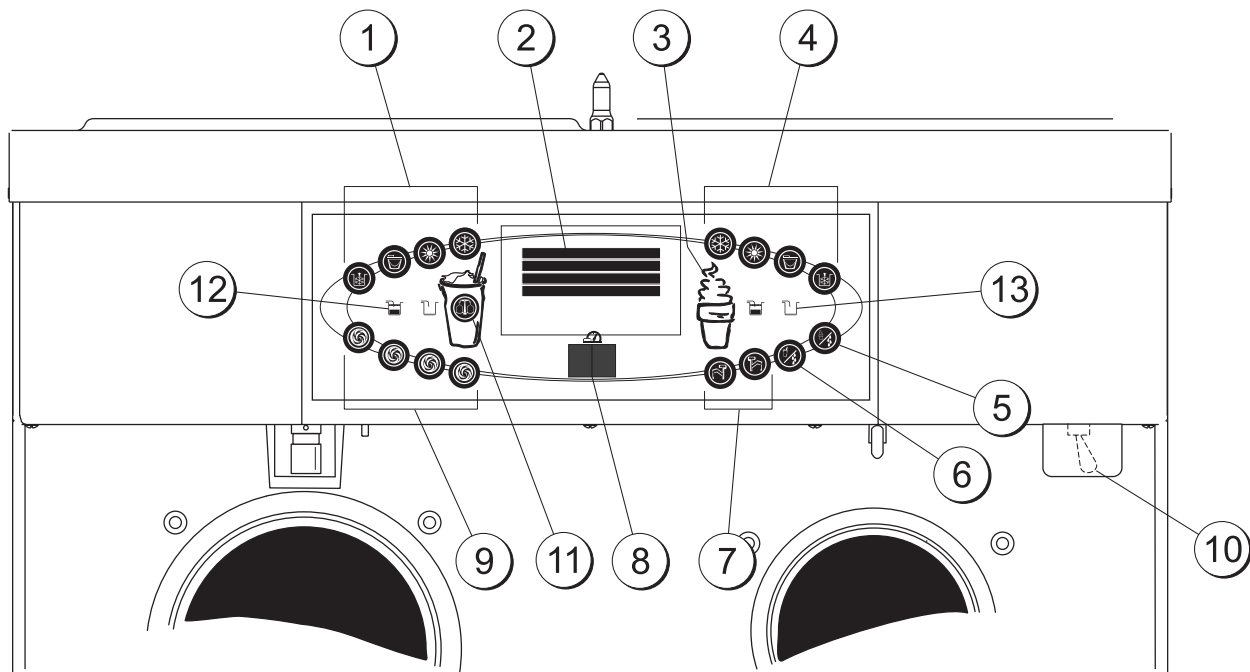

Figure 3

ITEM	DESCRIPTION	FUNCTION
1	Keypad-Shake	Used for selecting operating functions on the shake side of the machine.
2	Display-Vacuum Fluorescent Menu (VFD)	Screen which displays menu options and notifies operator if a fault is detected.
3	Keypad-Menu (Entry/Exit)	Used to select the Manager or Service Menu or to exit the Menu Display.
4	Keypad-Soft Serve	Used for selecting operating functions on the soft serve side of the machine.
5	Standby-Soft Serve	Indicates when the soft serve side is in the Standby mode.
6	Standby-Shake	Indicates when the shake side is in the Standby mode.
7	Keypad-Topping Heater	Used to activate the topping rail heaters.
8	Display-LED Dual (Brush Clean Countdown)	Displays the number of days before brush cleaning is required.
9	Keypad-Flavor Select	Used for selecting the desired shake flavor to be dispensed. Also used for opening and closing the draw valve when cleaning, sanitizing, and priming the shake side.
10	Switch-Power	When placed in the ON position, allows control panel operation.
11	Keypad-Calibrate Menu	Used to access the Calibrate Menu containing options for calibrating the syrup dispensing rate or priming and flushing the syrup lines.
12	Indicator Light-Mix Low	Illuminates when the mix hopper has a low supply of mix and should be refilled as soon as possible.
13	Indicator Light-Mix Out	Illuminates when the mix hopper has an insufficient supply of mix to operate the freezer. The Auto mode will be locked out and the machine will be placed in the Standby mode.

Symbol Definitions

To better communicate in the International arena, the words on many of our operator keys have been replaced by symbols to indicate their functions. Your Taylor equipment is designed with these International symbols.

The following chart identifies the symbol definitions.

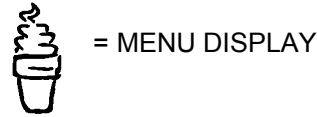
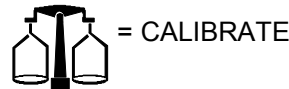
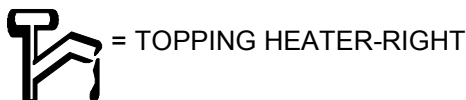
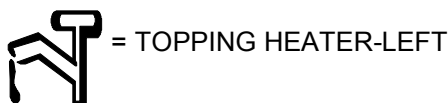
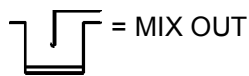
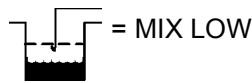
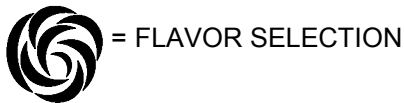
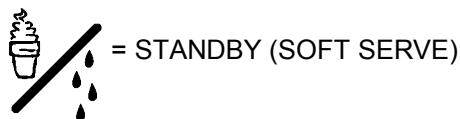
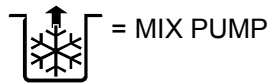
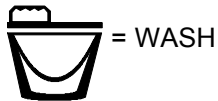
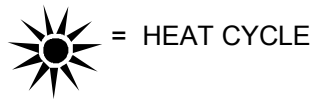
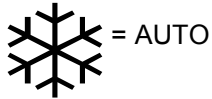

Power Switch



When placed in the ON position, the power switch allows control panel operation.

Vacuum Fluorescent Display

The vacuum fluorescent display (VFD) is located on the front control panel. During normal operation the display is blank. The display is used to show menu options and notifies the operator if a fault is detected. On International models, the display will indicate the temperature of the mix in each hopper.

Indicator Lights

MIX LOW - When the MIX LOW symbol  is illuminated, the mix hopper has a low supply of mix and should be refilled as soon as possible.

MIX OUT - When the MIX OUT  symbol is illuminated, the mix hopper has been almost completely exhausted and has an insufficient supply of mix to operate the freezer. At this time, the AUTO mode is locked out and the freezer will be placed in the STANDBY mode. To initiate the refrigeration system, add mix to the mix hopper and touch the AUTO symbol . The freezer will automatically begin operation.

Heat Mode Symbol

When the HEAT MODE symbol  is illuminated, the freezer is in the process of a heat cycle. The heat mode symbol may be selected to start a heat cycle following a freezer soft lock condition.

For some International models, the heat symbol can be selected to manually start a heat cycle at any time.

Brush Clean Countdown - Displays the number of days before the next brush cleaning is required. When the display has counted down to “1”, the machine must be disassembled and brush cleaned within 24 hours.

Power Up

When the machine is powered the control system will initialize to perform a system check. The screen will display “INITIALIZING”. There will be four types of data the system will check: LANGUAGE, SYSTEM DATA, CONFIG DATA, and LOCKOUT DATA.

During the INITIALIZING... LANGUAGE screen, the alarm will be on. If the system detects corrupt data during INITIALIZING, the following display will alert the operator that the control settings may have been changed (See Figure 4.)

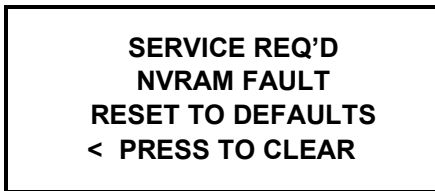

Figure 4

Once the system has initialized, the number of days remaining before the next required brush cleaning is indicated on the control panel and the SAFETY TIMEOUT screen is displayed with the alarm turned on. (See Figure 5.)



Figure 5

The SAFETY TIMEOUT screen will be displayed with the alarm on, for 60 seconds or until any control symbol is selected.

After the safety timeout has been completed and the power switch is OFF, the following screen is displayed. (See Figure 6.)

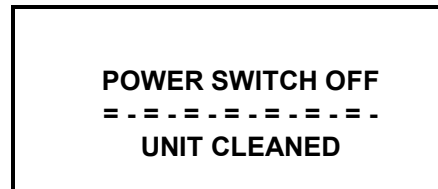

Figure 6

Power Switch ON

When the power switch is placed in the ON position, the control panel touch keys become operative. The VFD will be either blank or indicate that the unit has been cleaned. (See Figure 7.)

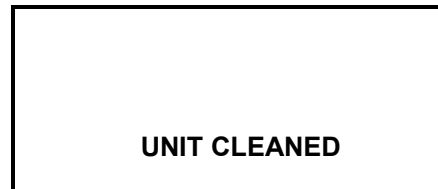

Figure 7

Display for International Models Only:

Some International models will continuously display the temperature of each mix hopper when the power switch is in the ON position. (See Figure 8.)

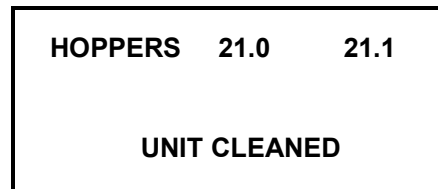

Figure 8

Heat Cycle

The HEAT symbols  on the control panel are illuminated throughout the heat treatment cycle. Two warning messages will be displayed on the screen. "DO NOT DRAW" will be displayed when the mix temperature is below 130°F (54.4°C). (See Figure 9.)



Figure 9

When the temperature of the mix is above 130°F (54.4°C) the screen will display a message indicating that HOT PRODUCT is in the machine. (See Figure 10.)



Figure 10





DO NOT attempt to draw product or disassemble the unit during the HEAT cycle. The product is hot and under extreme pressure.

In the HEAT cycle, the mix temperature in the hoppers and freezing cylinders must be raised to 151°F (66.1°C) within 90 minutes.

When the heating phase is complete, the freezer goes into the holding phase of the cycle. The holding phase will keep the temperature above 151°F (66.1°C) for a minimum of 30 minutes.

The final phase of the heat treatment cycle is the cooling phase. The freezer must cool the mix below 41°F (5°C) within two hours.

When the entire heat cycle has been completed, the HEAT symbols  will no longer be illuminated. The machine will enter the STANDBY mode (STANDBY symbols  and  illuminate). The machine can be placed in AUTO or left in STANDBY.

Freezer Lock-Out

Heat Cycle Failure Messages

To comply with health codes, heat treatment system freezers **must** complete a heat treatment cycle daily, and **must** be disassembled and brush cleaned a minimum of every 14 days. Brush cleaning is the normal disassembly and cleaning procedure found in the Operator Manual. Failure to follow these guidelines will cause the control to lock the freezer out of the AUTO mode.

Always comply with local guidelines for the maximum number of days allowed between brush clean cycles. (See the Manager/Service Menu for setting the Brush Clean interval, on page 21.)

If the Heat Treatment Cycle fails, the VFD will display a failure message and return the freezer to the STANDBY mode. A “lock” is defined as a special STANDBY mode of operation which does not allow the machine to operate in the AUTO mode.

There are two types of freezer lock conditions that can occur: Hard Lock or Soft Lock. A Hard Lock requires the machine be disassembled and brush cleaned. A Soft Lock can be corrected by either disassembling and brush cleaning the machine, or by starting another heat treatment cycle.

Hard Lock: There are two causes of a hard lock failure:

1. The brush clean timer has elapsed (maximum setting of 14 days). (See Figure 11.)

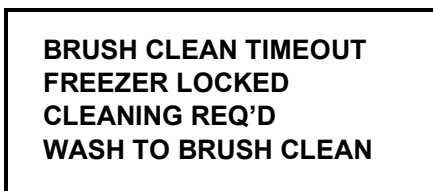

Figure 11

Selecting the WASH symbol  will display the following screen. (See Figure 12.)



Figure 12

2. There has been a thermistor failure (freezing cylinder, hopper, or glycol) during the heat treatment process. (See Figure 13.)

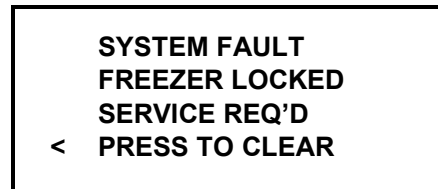

Figure 13

Selecting the CALIBRATE symbol  will indicate which thermistor caused the Hard Lock. (See Figure 14.)



Figure 14

If the machine has hard locked and an attempt is made to enter AUTO, the machine will enter the STANDBY mode and display the following message. (See Figure 15.)



Figure 15

To restore the message that identified the reason for the hard lock, turn the power switch OFF for five seconds and then return the power switch to the ON position. The original message with the reason for the Hard Lock will be displayed. The FAULT DESCRIPTION can also be found in the Manager or Service Menu (See page 22.)

The FREEZER LOCKED message will remain on the display until the brush clean requirements are fulfilled. The freezer must be disassembled in order to activate the five minute timer on the display screen. Once the timer counts down to zero, the lockout is cleared.

Soft Lock: If a heat treatment cycle has not been initiated within the last 24 hours, a soft lock failure will occur. A soft lock allows the operator to correct the cause of the soft lock. The operator has the option of either starting another heat cycle or brush cleaning the machine. When a soft lock occurs, the machine will go into the STANDBY mode. The following message is displayed on the screen. The reason for the soft lock is indicated on the second line. (See Figure 16.)

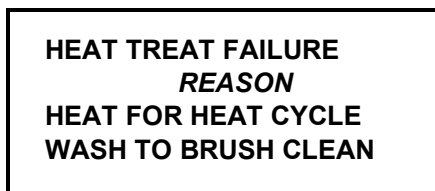



Figure 16

If the reason for the soft lock has been corrected, selecting the HEAT symbol  initiates a Heat Cycle immediately. Selecting the WASH symbol  when the above message is displayed will hard lock the machine and brush cleaning will be necessary.

Reasons For Soft Lock

Following are the variable messages for soft lock failures that appear on the second line of the screen.

Power Switch Off

This soft lock will occur if the power switch is in the OFF position and greater than 24 hours have passed since the start of the 14 day timer, or the start of the last successful Heat Treatment Cycle.

Mix Out

This soft lock will occur if one or both sides has a mix out condition and greater than 24 hours have passed since the start of the 14 day timer or the start of the last successful Heat Treatment Cycle.

Auto or Standby Off

This soft lock will occur if one or both sides is in the OFF mode and greater than 24 hours have passed since the start of the 14 day timer or the start of the last successful Heat Treatment Cycle.

No Heat Cycle Tried

No Heat Treatment Cycle was performed in the 24 hours after the start of the 14 day timer, or the start of the last successful Heat Treatment Cycle. (AUTO HEAT TIME was advanced, a power loss was experienced at the time the cycle was to occur, or a heat cycle failure not due to a thermistor failure.)

If the following screen appears, a soft lock has occurred during the heat treatment cycle. (See Figure 17.)

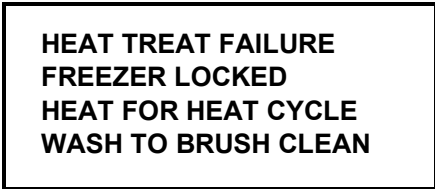

Figure 17

A soft lock can also occur any time during operation when the hopper or freezing cylinder temperature rises above 59°F (15°C), or the temperature rises and remains above 41°F(5°C) for more than four hours. If a PRODUCT OVER TEMPERATURE condition occurs during operation, the following screen will appear. (See Figure 18.)

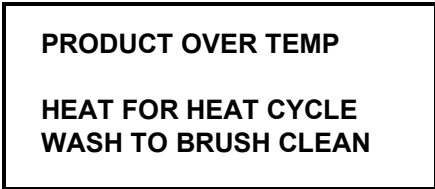



Figure 18

When one of these messages appears, automatic freezer operation cannot take place until the freezer is disassembled and brush cleaned, or has completed a heat treatment cycle. Select the HEAT symbol  to start a heat cycle, or select the WASH symbol  to disassemble and brush clean the machine.

Once the freezer is unlocked by starting a heat treatment cycle the HEAT symbol  will illuminate and the following message will be displayed on the screen. (See Figure 19.)



Figure 19

If the WASH symbol  is selected to clear the lockout by brush cleaning the machine, the FREEZER LOCKED message will remain on the display until the brush clean requirements are fulfilled. The freezer must be disassembled in order to activate the five minute timer on the display screen. Once the timer counts down to zero, the lockout is cleared. (See Figure 20.)



Figure 20

To restore the message that identified the reason for the soft lock, turn the power switch OFF for five seconds, and then return the power switch to the ON position. The original message with the reason for the soft lock will be displayed. (See Figure 21.)

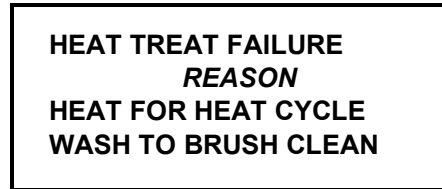

Figure 21

The FAULT DESCRIPTION can also be found in the Manager and Service Menus. (See page 22.)

Note: A record of Heat Cycle Data and Lock Out History can be found in the Manager and Service Menus. (See page 23.)

Service Menu

The Service Menu option allows a trained service technician to access and modify critical operating parameters for the machine. All the menu screens found in the Manager's Menu are also included in the Service Menu. To access the menu, touch the center of the CONE symbol.

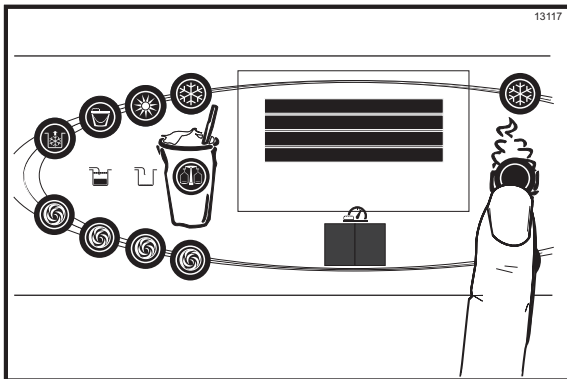











Figure 22

The shake AUTO symbol , the OPTIONAL FLAVOR symbol  and the CONE symbol  will be illuminated when the ACCESS CODE screen is displayed.

In the Menu program, the shake side AUTO symbol , OPTIONAL FLAVOR symbol , and CALIBRATION symbol  will function as menu keys.

AUTO  - increases the value above the cursor and used to scroll upward in text displays

OPTIONAL FLAVOR  - decreases the value above the cursor and used to scroll downward in text displays.



CALIBRATION  - advances the cursor position to the right and is used to select menu options.

Note: You will not be able to dispense shakes while accessing the Service Menu options, except when the CURRENT CONDITIONS screen is displayed.

The soft serve side will continue operation in the mode it was in when the Menu was selected. However, the soft serve side control keys will not be

illuminated and are non-functional when a menu screen is displayed. The control keys for both sides are only functional when the CURRENT CONDITIONS screen is displayed.

Entering Access Code

With the ACCESS CODE screen on the display use the AUTO  or OPTIONAL FLAVOR  symbols to set the first code number in the cursor position. When the correct number is selected, touch the CALIBRATION symbol  to move the cursor to the next number position.

The access code for the Service Menu is 5231. The access code for the Operator Menu is 8309. (See Figure 23.)

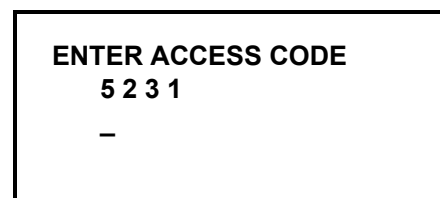



Figure 23

Continue to enter the proper access code numbers until all four numbers are displayed, and then touch the CALIBRATION symbol . The Service Menu list will display on the screen, provided the correct access code is entered.

If an incorrect number is entered for the access code, the display will exit the Menu program when the CALIBRATION symbol  is selected. (See Figure 24.)

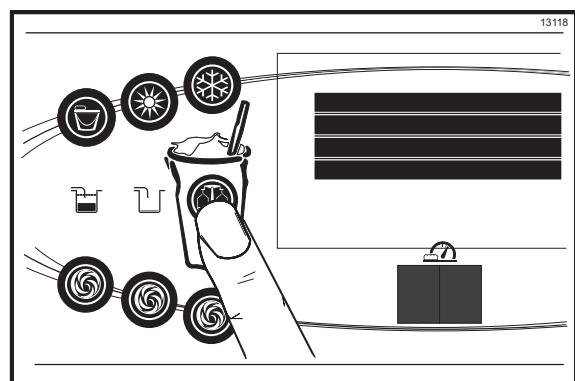





Figure 24

Service Menu Options

Touch the AUTO symbol  or OPTIONAL FLAVOR symbol  to move up or down through the Menu. Select a Menu option by aligning the option with the arrow on the left side of the screen, and then touch the CALIBRATION symbol . Exit the Menu program by selecting EXIT FROM MENU or touch the CONE symbol .

The following menu options are listed in the Service Menu:

Note: Options “EXIT FROM MENU” through “CURRENT CONDITIONS” can also be accessed through the Manager’s Menu.

EXIT FROM MENU
VERIFY CALIBRATION
RESET DRAW COUNTER
SET CLOCK
AUTO HEAT TIME
AUTO START TIME
STANDBY MODE
BRUSH CLEAN CYCLE
MIX LEVEL AUDIBLE
FAULT DESCRIPTION
LOCKOUT HISTORY
HEAT CYCLE SUMMARY
HEAT CYCLE DATA
SYSTEM INFORMATION
CURRENT CONDITIONS
TEMPERATURE SCALE
STANDBY TEMPERATURE
HOPPER TEMPERATURE
GLYCOL TEMPERATURE
VISCOSITY SETTING
COMPRESSOR CYCLE TIME
COMPRESSOR ON DELAY
BEATER OFF DELAY
MIX PUMP OFF DELAY
WHITESPOT ADJUST
CAL SYRUP TIME
DRAW SAFETY TIME
EDIT UNIT ID
CALIBRATE PROXIMITY SWITCH
SELECT LANGUAGE
ABORT HEAT CYCLE
SYRUP MOTOR SETUP

EXIT FROM MENU

Selecting “EXIT FROM MENU” will exit the Menu and the return the control panel symbols to normal operation.

VERIFY CALIBRATION

The VERIFY CALIBRATION option is used to verify that the amount of syrup dispensed is within the proper specification. (See Figure 25.)

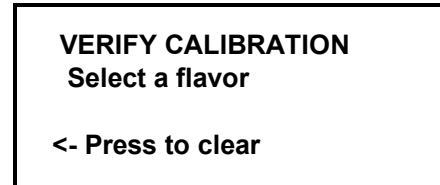



Figure 25

Remove the syrup valve from the dispensing door. With the line fully primed with syrup, position the syrup valve over the small chamber side of the divided syrup cup, and then select the corresponding favor selection. Syrup will flow into the cup for 5 seconds (7 seconds for Triple Thick Shake Syrup) and then automatically stop flowing. Place the cup on a flat surface and check the amount of syrup dispensed. If the level is not within the correct specification, the flavor will need to be recalibrated.

It is recommended to verify the calibration of each syrup flavor and note any flavors that need to be recalibrated before exiting the Menu to access the CALIBRATION Menu.

Select the CALIBRATION symbol  to exit the VERIFY CALIBRATION screen and return to the Menu list.

RESET DRAW COUNTER

The SERVING COUNTER screen is used to check or reset the number of servings dispensed from the machine. The SERVING COUNTER will automatically reset to zero when the machine is brush cleaned. (See Figure 26.)

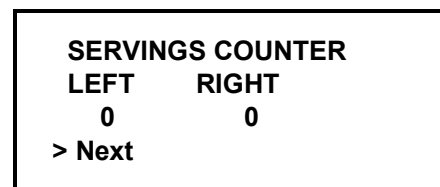





Figure 26

Reset the SERVING COUNTER by selecting the CALIBRATION symbol  to advance to the next screen. Select the AUTO symbol  to move the arrow (>) to YES and select the CALIBRATION symbol . The servings counter will reset to zero and exit back to the Menu. (See Figure 27.)

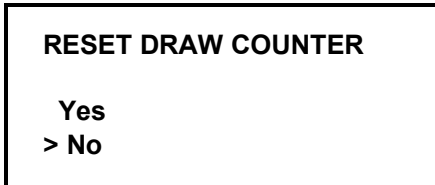

Figure 27

SET CLOCK

The SET CLOCK option allows the manager or service technician to adjust the control clock date and time. The date and time may only be changed after the freezer has been manually cleaned but before it has been placed in the AUTO or STANDBY mode. The following message will be displayed if the SET CLOCK option is selected when the machine is not in a brush clean state. (See Figure 28.)

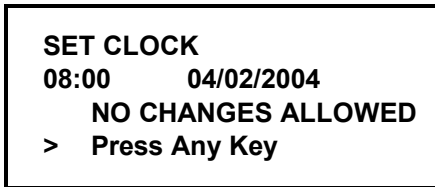



Figure 28

To change the date or time, select the SET CLOCK option in the menu. Touch the AUTO symbol  to advance the arrow from Exit to Change, and then touch the CALIBRATION symbol  to select the Change option. (See Figure 29.)

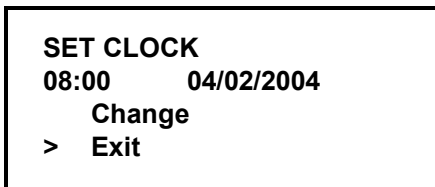





Figure 29

Change the time by touching the AUTO  or OPTIONAL FLAVOR symbol  with the cursor under the hour position. Move the cursor to the minutes by selecting the CALIBRATION symbol . Once the correct minutes are entered, select the CALIBRATION symbol  to advance the cursor to the month. (See Figure 30.)

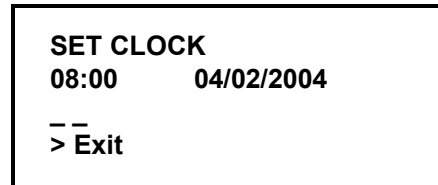



Figure 30

Enter the correct month, day, and year. Then select the CALIBRATION symbol  to advance to the DAYLIGHT SAVING TIME screen. (See Figure 31.)

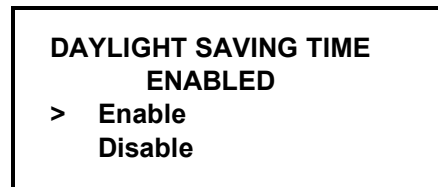



Figure 31

The Daylight Saving Time feature, when enabled, will automatically adjust the control clock for daylight saving time. To Disable the Daylight Saving Time feature, select the AUTO symbol  to move the arrow to Disable. Then touch the CALIBRATION symbol  to save the new setting.

AUTO HEAT TIME

The AUTO HEAT TIME screen allows the manager or service technician to set the time of day in which the heat treatment cycle will start. (See Figure 32.)



Figure 32

Note: Do not advance the Auto Heat Time setting except on the day the unit is brush cleaned. Increasing the time between heat cycles will cause the machine to soft lock if the start of the cycle does

not begin within 24 hours from the start of the previous heat treatment cycle.







To set the AUTO HEAT TIME select the AUTO symbol  to move the arrow to Change. Then select the CALIBRATION symbol . The screen will display the time with the cursor under the hour position. (See Figure 33.)



Figure 33

Select the AUTO symbol  or the OPTIONAL FLAVOR symbol  to increase or decrease the hour to the desired setting. Then move the cursor to the minutes position by selecting the CALIBRATION symbol . Adjust the setting for minutes, then select the CALIBRATION symbol  to save the setting and return to the AUTO HEAT TIME screen. Select the CALIBRATION symbol  to exit the screen and return to the Menu.

AUTO START TIME

The AUTO START TIME option allows the manager or service technician to set the time of day at which the machine automatically enters the AUTO mode from the STANDBY mode. The machine must be in the STANDBY mode without a freezer lock condition in order to AUTO start at the programmable time. The AUTO START TIME can be disabled and will require starting the AUTO mode manually. (See Figure 34.)

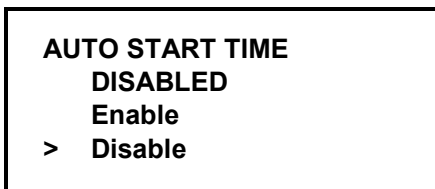



Figure 34

Enable the AUTO START TIME by selecting the AUTO symbol  to move the arrow up to Enable. Select the CALIBRATION symbol  to advance to the next screen. (See Figure 35.)

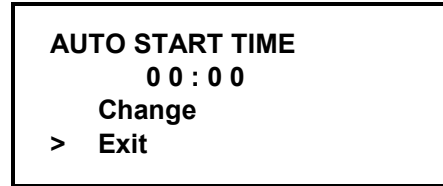



Figure 35

Program the AUTO START TIME by selecting the AUTO symbol  to move the arrow to Change. Select the CALIBRATION symbol  to advance to the next screen. (See Figure 36.)

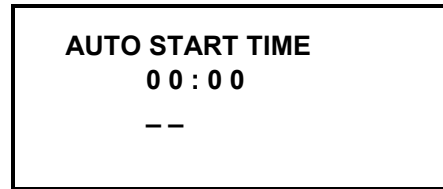









Figure 36

Program the AUTO START TIME by increasing (AUTO symbol ) or decreasing (OPTIONAL FLAVOR symbol ) the hour setting above the cursor. Select the CALIBRATION symbol  to advance the cursor and program the minutes setting.

Select the CALIBRATION symbol  to return to the previous screen with the new time setting displayed. Select the CALIBRATION symbol  to exit the screen and return to the Menu.

STANDBY MODE

The Standby option is used only on models which have the control panel Standby keys disabled.

The STANDBY option is used to manually place the left or right side in the standby mode during long, no draw periods. Select the STANDBY screen from the Menu. Select the AUTO symbol  to move the arrow up to the left (shake) or right (soft serve) side. Select the CALIBRATION symbol  to activate Standby for the selected side.

Repeat the steps to activate Standby on the remaining side. (See Figure 37.)

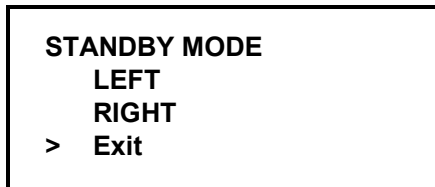

Figure 37

Discontinue Standby operation for either side by exiting the Menu and select the AUTO mode.

BRUSH CLEAN CYCLE

The BRUSH CLEAN CYCLE option allows the manager or service technician to select the maximum number of days between brush cleaning the machine. The brush clean cycle may only be changed after the freezer has been manually cleaned but before it has been placed in the AUTO or STANDBY mode.

The following message will be displayed if the BRUSH CLEAN CYCLE option is selected when the machine is not in a brush clean state. (See Figure 38.)

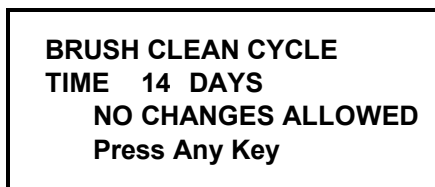



Figure 38

Change the number of days between brush clean intervals by selecting the AUTO symbol  to decrease the days or the OPTIONAL FLAVOR



symbol  to increase the number of days. Select the CALIBRATION symbol  to save the setting and exit back to the Menu. The number of days displayed on the brush clean counter will change to the new setting. (See Figure 39.)



Figure 39

Always comply with local guidelines on the number of days allowed between brush clean cycles.

MIX LEVEL AUDIBLE

The MIX LEVEL AUDIBLE option, when enabled, will alert the operator with an audible tone when there is mix low or mix out condition. The following screen is displayed upon selecting this option. (See Figure 40.)

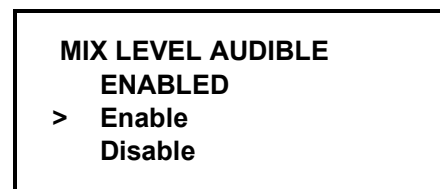



Figure 40



Disable the audible tone feature by selecting the OPTIONAL FLAVOR symbol  to move the arrow to DISABLE. Select the CALIBRATION symbol  to save the new setting and return to the Menu. The control panel icons for Mix Low and Mix Out will illuminate as the mix level drops in the hopper but the audible tone will be disabled.

FAULT DESCRIPTION

The FAULT DESCRIPTION display will indicate if there is a fault with the freezer and the side of the freezer where the fault occurred. When no faults are detected the following screen will be displayed. (See Figure 41.)



Figure 41

Select the CALIBRATION symbol  to display the next fault found or return to the Menu if no other faults exist. Selecting the CALIBRATION symbol  any time faults are displayed will clear the faults if corrected, upon returning to the Menu screen.

Listed below are the variable messages which will appear, along with an explanation for the corrective action.

NO FAULT FOUND - There was no fault found in the freezer. Nothing will appear on the screen after this variable message appears.

BEATER OVERLOAD - Press the beater reset button firmly for the side of the freezer with the fault.

HPCO COMPRESSOR - Place the power switch in the OFF position. Wait 5 minutes for the machine to cool. Place the power switch in the ON position and restart each side in AUTO.

HOPPER THERMISTOR BAD - Place the power switch in the OFF position. Replace the bad probe.

BARREL THERMISTOR BAD - Place the power switch in the OFF position. Replace the bad probe.

GLYCOL THERMISTOR BAD - Place the power switch in the OFF position. Replace the bad probe.

LOCKOUT HISTORY

The LOCKOUT HISTORY screen displays a history of the last 40 soft locks, hard locks, brush clean dates, or aborted heat cycles. Page numbers are indicated in the upper right hand corner. Page 1 always contains the most recent failure. (See Figure 42.)

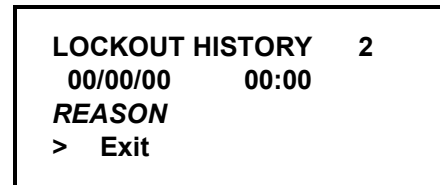



Figure 42

The second line of the screen displays the date and time a failure occurs. The third line indicates the reason for a failure, or will indicate if a successful brush cleaning has occurred. Some failures occur with multiple reasons. When this occurs, a page will be generated for each reason.

Select the AUTO symbol  or OPTIONAL FLAVOR symbol  to advance forward or backward to view each screen. Listed below are the variable messages that may appear.

Faults Occurring While Entering a Heat Treatment Cycle

POWER SWITCH OFF - The power switch is OFF.

AUTO OR STBY OFF - The control was not in AUTO or STANDBY.

MIX OUT FAILURE - A mix out condition was present.

NO HEAT CYCLE TRIED - The Auto Heat Time was set to attempt a heat cycle more than 24 hours after the last successful heat cycle.

Faults Occurring While in Heat Mode

HEAT MODE FAILURE - The maximum allowable heat mode time exceeded 90 minutes.

COOL MODE FAILURE - The maximum allowable cool mode time exceeded 120 minutes.

TOTAL TIME FAILURE - The maximum allowable total heat treatment time exceeded 4 hours.

BRUSH CLEAN TIMEOUT - The total days in operation exceeded the brush clean cycle setting.

POWER SWITCH OFF - The power switch was turned OFF during the heat cycle.

POWER FAIL IN H/C - A power failure occurred during the heat treatment cycle.

(L/R) MIX LOW FAILURE - The mix level in the (left/right) Hopper is too low for a successful heat cycle.

(L/R) BEATER OVLD H/C - The overload tripped for the (left/right) side beater motor.

(L/R) BRL THERM FAIL - The thermistor sensor for the (left/right) side barrel failed.

(L/R) HOPPER THERM FAIL - The thermistor sensor for the (left/right) side hopper failed.

(L/R) HPCO H/C - The (left/right) side high pressure switch opened during the heat treatment cycle.

Faults Occurring While in AUTO Mode

(L/R) HPR>41F (5C) AFTER 4 HR - The mix temperature in the left or right hopper was above 41°F (5°C) more than four hours.

(L/R) BRL>41F (5C) AFTER 4 HR - The mix temperature in the left or right barrel was above 41°F (5°C) more than four hours.

(L/R) HPR>41F (5C) AFTER PF - The mix temperature in the left or right hopper was above 41°F (5°C) more than four hours following a power failure.

(L/R) BRL>41F (5C) AFTER PF - The mix temperature in the left or right barrel was above 41°F (5°C) more than four hours following a power failure.

(L/R) HPR>59F (15C) - The mix temperature in the left or right hopper exceeded 59°F (15°C).

(L/R) BRL>59F (15C) - The mix temperature in the left or right barrel exceeded 59°F (15°C).

HEAT CYCLE SUMMARY



The HEAT CYCLE SUMMARY screen displays the hours since the last heat cycle, the hours since the product temperature was above 150°F (65.6°C), and the number of heat cycles completed since the last brush clean date. (See Figure 43.)

HEAT CYCLE SUMMARY	
HRS SINCE HC	0
HRS SINCE 150.0	0
HRS SINCE BC	0

Figure 43

HEAT CYCLE DATA



The HEAT CYCLE DATA screen contains a record of up to 366 heat treatment cycles. The most recent heat cycle data will be shown first. Each heat cycle record or page has two screens. The first screen displays the month and day of the heat cycle, the start time and end time, and which side of the machine underwent the heat treatment cycle; L for Left side, R for Right side, and B for both sides. Line 3 displays the total time in each heat cycle phase. Line 4 displays the glycol temperature at the completion of the heat cycle and the page number.

Select the AUTO symbol  to advance forward through the data pages. Select the OPTIONAL FLAVOR symbol  to reverse the page direction. (See Figure 44.)

00/00	00:00	00:00	B
HEAT	OVER	COOL	RC
00:00	00:00	00:00	*
TEMP AT END	0.0		1

Figure 44

The second screen will have the same page number and display the temperature recorded in each hopper, barrel, and the temperature of the glycol when the heat cycle was terminated. The left hopper and barrel temperature is displayed on line 2 and the right side temperatures on are line 3. The time in the last phase of heat cycle, whether successful or failed, is displayed on line 4.

Select the AUTO symbol  to advance to the next page or the OPTIONAL FLAVOR symbol  to view the previous page. (See Figure 45.)

HOPPER	BARREL	GLYCOL	
000.0	000.0	000.0	
000.0	000.0		
PHASE TIME:	00:00		1

Figure 45

Heat Cycle Failure codes will display on the first screen on line 2 if a failure occurred. (See Figure 46.)

HOPPER	BARREL	GLYCOL	
000.0	000.0	000.0	HT
000.0	000.0		
PHASE TIME:	00:00		1

Figure 46

Listed below are variable failure code messages which could appear on line 2.

- HT Heat Time Too Long
Mix temperature did not rise above 151°F (66.1°C) in less than 90 minutes.
- CL Cool Time Too Long
Mix temperature in the hopper and freezing cylinder did not fall below 41°F (5°C) in less than 120 minutes.
- TT Total Time Too Long
The heat treatment cycle must be completed in no more than 4 hours.
- MO Mix Out Condition
A mix out condition was detected at the start or during the heat cycle.
- ML Mix Low Condition
The Heat Phase or Cool Phase time was exceeded and a mix low condition was present.
- BO Beater Overload Condition
A beater overload occurred during the heat cycle.
- HO High Pressure Cut-Out Condition
A high pressure cut-out condition occurred during the heat cycle.
- PF Power Failure
A power failure caused the Heat Phase, Cool Phase, or Total Cycle Time to exceed the maximum allowed time. If a power failure occurs, but the heat treatment cycle does not fail, an asterisk(*) will appear on the third line of the display.
- PS Power Switch OFF
The power switch was placed into the OFF position during the heat cycle.
- TH Thermistor Switch OFF
A thermistor probe has failed.
- RC Record Cleared
Data has not been written to the page or cleared due to corrupt data.
- OP Operator Abort
Indicates the heat cycle was aborted in the OPERATOR ABORT option in the service menu.
- PD Product Door Not in Place
A product door is not in place or is loose.

SYSTEM INFORMATION

The SYSTEM INFORMATION is displayed on three separate screens. The first screen contains the control and software version installed in the machine. (See Figure 47.)

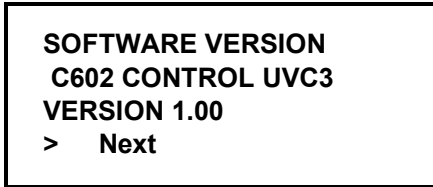



Figure 47

Select the CALIBRATION symbol  to advance to the next system information screen containing the software language version. (See Figure 27.)

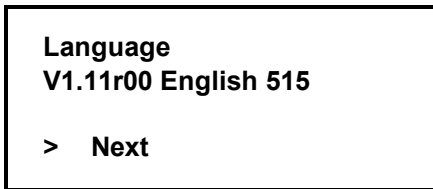



Figure 48

Select the CALIBRATION symbol  to advance to the third system information screen containing the model bill of material and machine serial number. Selecting the CALIBRATION symbol  again will return to the Menu list. (See Figure 49)

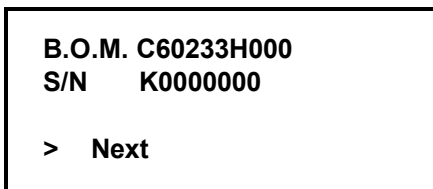



Figure 49

CURRENT CONDITIONS

The CURRENT CONDITIONS screen provides the viscosity readings for the product when the side is running and hopper and barrel temperatures for both sides of the machine. The left column displays the readings for the shake side and the right column displays the soft serve side readings. The bottom line in the display indicates the current glycol temperature. (See Figure 50.)

VISC	0	0.0
HOPPER	41.0	41.0
BARREL	41.0	41.0
GLYCOL		41.0

Figure 50

CURRENT CONDITIONS is the only Menu screen that will return the left and right side control panel keys to normal operation. The Menu keys will not be illuminated when this option is selected so shakes can be dispensed and all panel touch keys are fully functional. Use this screen when you wish to remain in the Menu and dispense a shake. Exit the CURRENT CONDITIONS screen and return to the Menu by selecting the CALIBRATION symbol .



Note: All screens from this point forward can only be accessed through the service menu.

TEMPERATURE SCALE

The TEMPERATURE SCALE option allows the service technician to choose the scale in which the machine will display all temperatures. (See Figure 51.)



Figure 51

To change the scale setting, use the AUTO symbol  or OPTIONAL FLAVOR symbol  to move the cursor along side of the desired temperature scale then touch the CALIBRATION symbol  to save the selection and return to the service menu.

STANDBY TEMPERATURE

The STANDBY TEMPERATURE option allows the service technician to adjust the freezing cylinder temperature in the Standby mode. In Standby, the machine will cycle the compressor (and beater) on if the temperature of the product in the freezing cylinder rises above the setpoint. The compressor will cycle off when the temperature of the product in the freezing cylinder drops 4°F (2.2°C) or more below the set point. (See Figure 52.)

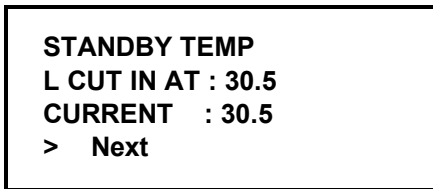

Figure 52

Adjust the temperature setting using the AUTO symbol ❄️ to increase the temperature or OPTIONAL FLAVOR symbol 🌀 to decrease the temperature. Save the setting by selecting the CALIBRATION symbol ⚖️ to advance to the next screen for the right side freezing cylinder Standby temperature setting. (See Figure 53.)

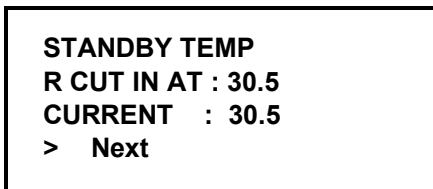

Figure 53

Select the CALIBRATION symbol ⚖️ to save the setting and return to the Service Menu.

HOPPER TEMPERATURE

The HOPPER TEMPERATURE menu allows the service technician to adjust the hopper temperature by which the glycol pump and the left and right glycol solenoids are controlled when the machine is operating in AUTO or STANDBY modes.

Hopper cooling is activated when the mix temperature rises above the set point temperature. When the temperature drops 2°F (1°C) below the set point the hopper cooling is discontinued. (See Figure 54.)

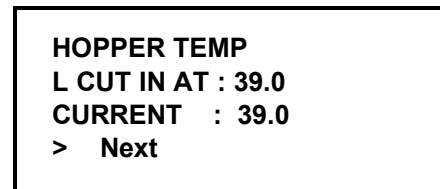

Figure 54

Adjust the temperature setting using the AUTO symbol ❄️ to increase the temperature or OPTIONAL FLAVOR symbol 🌀 to decrease the temperature. Save the setting by selecting the CALIBRATION symbol ⚖️ to advance to the next screen for the right side Hopper temperature setting. (See Figure 55.)

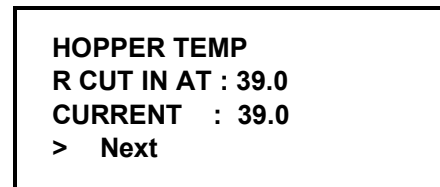

Figure 55

Select the CALIBRATION symbol ⚖️ to save the setting and return to the Service Menu.

GLYCOL TEMPERATURE

The GLYCOL TEMPERATURE allows the Service Technician to adjust the glycol temperature used to control the glycol heater in the HEAT and HOLD phases of the Heat Treatment Cycle.

When the glycol temperature falls 6°F (3.3°C) or more below the set point, the glycol heater is activated. When the glycol temperature rises above the set point, the heater is de-activated. The factory glycol temperature setting is 178°F (81°C). (See Figure 56.)

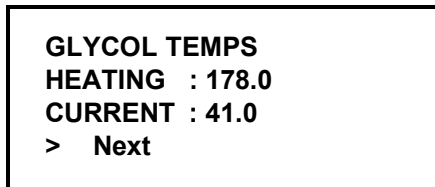

Figure 56

Adjust the temperature setting using the AUTO symbol ❄️ to increase the temperature or OPTIONAL FLAVOR symbol 🌀 to decrease the temperature. Save the setting by selecting the CALIBRATION symbol 🛠️ to advance to the next screen for the right Glycol temperature setting in the HOLDING phase. (See Figure 57.)

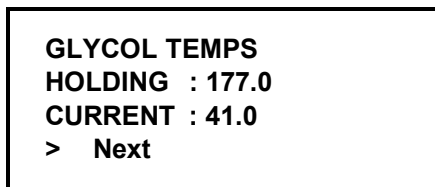

Figure 57

The GLYCOL HOLDING TEMPERATURE set point controls the glycol heater in the HOLDING phase of the Heat Treatment Cycle. When the glycol temperature is 6°F (3.3°C) or more below the set point, the glycol heater is activated. When the glycol temperature rises above the set point, the heater is de-activated. The factory setting for the glycol holding temperature is 177°F (81°C).

Adjust the temperature setting using the AUTO symbol ❄️ to increase the temperature or OPTIONAL FLAVOR symbol 🌀 to decrease the temperature. Select the CALIBRATION symbol 🛠️ to save the setting and return to the Service Menu.

VISCOSITY SETTING

The viscosity setting option allows the service technician to adjust the viscosity at which the compressor cycles off during the AUTO mode of operation.

Select the AUTO symbol ❄️ to move the cursor up to the left or right side viscosity setting. (See Figure 58.)

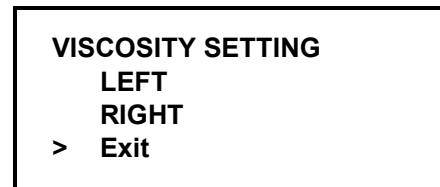

Figure 58

Shake Viscosity Setting (Left):

Select the AUTO symbol ❄️ to increase the viscosity setting or the OPTIONAL FLAVOR symbol 🌀 to decrease the setting. (See Figure 59.)

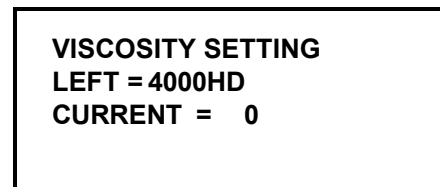



Figure 59

Note: A Hedlund (HD) is a Taylor factory defined unit of measure representing the relative product viscosity (thickness). Product in the shake machines is normally set at a viscosity ranging from 4,000 to 7,500 HD's to accomplish a neutral frozen product temperature around 23° - 26°F (-5 to -3.3°C).

While the beater motor is on, the current viscosity indicated on the display is updated continually. When the beater motor is off, this value is zero.

Select the CALIBRATION symbol 🛠️ to save the setting and return the Service Menu.

Soft Serve Viscosity Setting (Right):

Enter the Viscosity option and select the AUTO symbol  to move the cursor up to the right side viscosity setting and select the CALIBRATION symbol . (See Figure 60.)

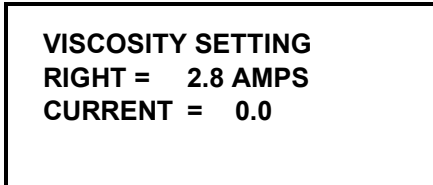







Figure 60

Select the AUTO symbol  to increase the viscosity setting or the OPTIONAL FLAVOR symbol  to decrease the setting. Select the CALIBRATION symbol  to save the setting and return to the screen to the Viscosity Setting menu.

Soft serve viscosity is measured by monitoring the amperage load of the beater motor. While the beater motor is on, the viscosity or amperage is indicated on the display. When the beater motor is off, this value is zero.

COMPRESSOR CYCLE TIME

The COMPRESSOR CYCLE TIME option allows the service technician to set the time that the compressor will cycle on in the AUTO mode when product is not dispensed from the machine. Compressor Cycle Times range from 5 – 15 minutes for shake and soft serve applications and is adjustable in one-minute intervals. Use the AUTO symbol  or the OPTIONAL FLAVOR symbol  to adjust the setting. The recommended cycle times are 5 minutes for shake and 10 minutes for soft serve.

The Left Compressor Cycle Time is displayed first. (See Figure 61.)

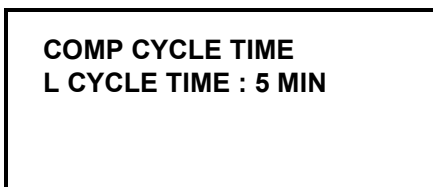



Figure 61

Advance to the next screen for the right side setting or return to the service menu by selecting the CALIBRATION symbol . (See Figure 62.)

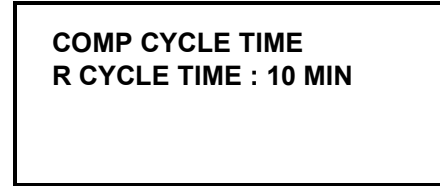



Figure 62

COMPRESSOR ON DELAY

The COMPRESSOR ON DELAY allows the service technician to adjust the time the compressor will delay starting when the unit is in the AUTO mode. The range for the delay time is 2 seconds to 10 seconds and is adjustable in one-second intervals.

Use the AUTO symbol  or the OPTIONAL FLAVOR symbol  to adjust the setting. The recommended setting is 5 seconds for shake and 2 seconds for soft serve applications.

The Left Compressor On delay screen is displayed first (See Figure 63.)



Figure 63



Advance to the next screen for the right side setting or return to the service menu by selecting the CALIBRATION symbol . (See Figure 64.)



Figure 64

BEATER OFF DELAY

The BEATER OFF DELAY allows the service technician to set the time the beater motor continues to run after the compressor has cycled off. The range for the delay time is 0 seconds to 10 seconds and is adjustable in one-second intervals. Use the AUTO symbol  or the OPTIONAL FLAVOR symbol  to adjust the setting. The recommended setting is 0 seconds for shake and soft serve applications.

The Left Beater Off Delay screen is displayed first (See Figure 65.)

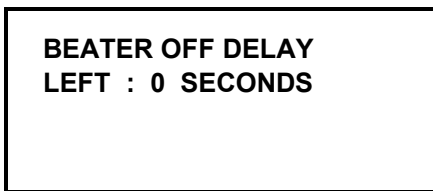



Figure 65

Advance to the next screen for the right side setting or return to the service menu by selecting the CALIBRATION symbol . See Figure 66.)

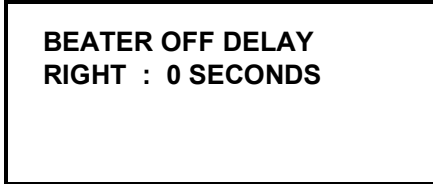



Figure 66

MIX PUMP OFF DELAY

The MIX PUMP OFF DELAY allows the service technician to set the amount of time the mix pump runs after the draw valve has closed (switch open). This adjustment is for the soft serve mix pump only.

The range is for the Pump Off Delay is 0 – 30 seconds and is adjustable in 1- second intervals.

Use the AUTO symbol  or the OPTIONAL FLAVOR symbol  to adjust the setting. The recommended setting is 10 seconds. (See Figure 67.)

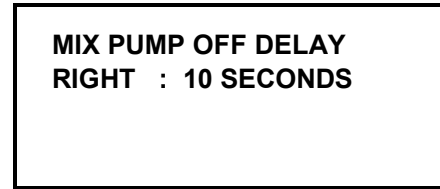



Figure 67

Select the CALIBRATION symbol  to return to the Service Menu.

WHITE SPOT ADJUST

This option allows the service technician to set the White Spot Adjustment for each syrup flavor. (See Figure 68.)

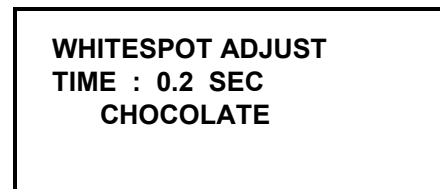





Figure 68

Select the AUTO symbol  to increase the whitespot setting or the OPTIONAL FLAVOR symbol  to decrease the setting.

The recommended White Spot Setting for standard shakes is 0.2 seconds. The recommended setting for Triple Thick Shakes is 0.4 seconds.

Select the CALIBRATION symbol  to save the setting and advance to the Whitespot Setting for the next flavor.

CAL SYRUP TIME

This option allows the service technician to adjust the Calibrate Syrup Time which determines the flow rate of the syrup.

Example: 1 oz.(28 g) syrup dispensed in 5 seconds.

The recommended Cal Syrup Time for standard shakes is 5.0 seconds and is 7.0 seconds for Triple Thick Shakes.

The following screen is displayed by selecting this option: (See Figure 69.)

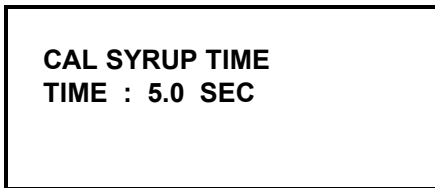





Figure 69

Select the AUTO symbol  to increase the time setting or the OPTIONAL FLAVOR symbol  to decrease the setting. Select the CALIBRATION symbol  to save the setting and return to the Service Menu.



DRAW SAFETY TIME

This option allows the service technician to adjust the Draw Safety Time used for closing the shake draw valve in the AUTO Mode if the fill level is not detected by the portion control sensor. The Draw Safety Time should be set approximately 5 seconds longer than the amount of time it takes to fill the largest serving size.

The following screen is displayed by selecting this option. (See Figure 70.)



Figure 70

Press the AUTO symbol  to increase the Draw Safety Time setting or the OPTIONAL FLAVOR symbol  to decrease the setting. Select the

CALIBRATION symbol  to save the setting and return to the Service Menu.

EDIT UNIT ID

This option allows the service technician to enter the factory Bill of Material (B.O.M.) code used to assemble the machine, the freezer Serial Number and the Store Identification Number. This information must be programmed in the service menu in order to view the information in the SYSTEM INFORMATION screens. (See Figures 71, 72 & 73.)

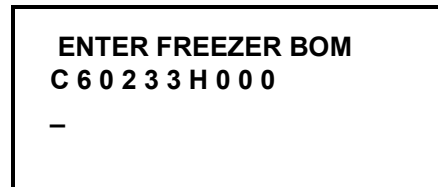





Figure 71

Select the AUTO symbol  to increase the value or OPTIONAL FLAVOR symbol  to decrease the value. Select the CALIBRATION symbol  to move the cursor to the right and advance to the serial number screen.

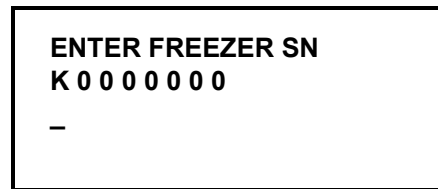



Figure 72

Enter the serial number from the unit's data label in the same manner as the BOM, then select the CALIBRATION symbol  to save the setting and advance to the store identification screen.

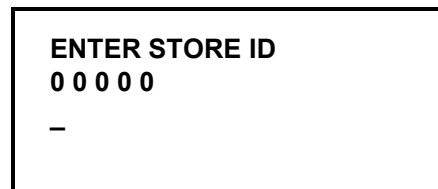



Figure 73

Enter the store number, then select the CALIBRATION symbol  to save the setting and return to the Service Menu.

CALIBRATE PROXIMITY SWITCH

This option allows the service technicians to adjust the mounting of the proximity switch. This procedure must be performed while the machine is fully assembled and properly primed. In addition, the product temperature must be above 32°F (0°C). If the temperature is below 32°F (0°C), the Temp. Error screen will be displayed. (See Figure 74.)

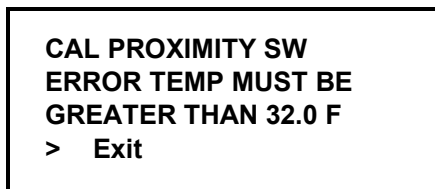

Figure 74

When the barrel temperature is above 32°F (0°C) the Cal Proximity screen will be displayed and the shake side beater motor will be activated. (See Figure 75.)

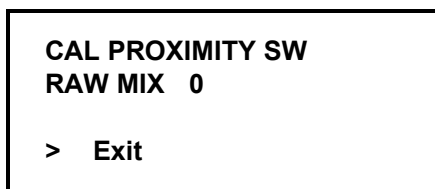





Figure 75

When the "CAL PROXIMITY SW" message is displayed, adjusting the distance between the proximity probe and the torque coupling will increase or decrease the raw viscosity displayed. When the raw viscosity is between 1000–1500, an audible tone will sound at regular intervals. The target setting is the middle of the audible tone range. Upon completion of the calibrating procedures, lock the switch down. Verify that the viscosity setting is correct after the switch is locked. Selecting the CALIBRATION symbol  will return to the Service Menu screen and discontinue beater motor operation.

SELECT LANGUAGE

The SELECT LANGUAGE option allows the service technician to select the language that will display on the fluorescent display. Several language options are available.

Use the OPTIONAL FLAVOR symbol  or AUTO symbol  to move the arrow to the desired language then touch the CALIBRATION symbol  to save the selection. (See Figure 76.)

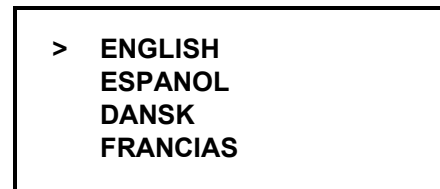



Figure 76

ABORT HEAT CYCLE

This option allows the service technician to abort the Heat Treatment Cycle if the machine is operating in a heat cycle. The screen below will be displayed upon selecting this option. Select the AUTO symbol  to move the arrow to "YES", and then select the CALIBRATION symbol  to abort the heat cycle and to return to the Service Menu. (See Figure 77.)

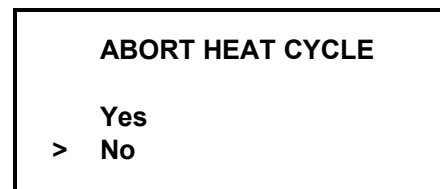

Figure 77

SYRUP MOTOR SETUP

The Syrup Motor Setup option allows the service technician to adjust the running speed for each syrup pump motor in the calibration mode and the reverse time for the pump motor.

The proper syrup motor setting should be set to gradually fill the calibration cup. If the syrup motor setting is too fast the syrup will fill the cup too fast to accurately stop the flow at the proper level.

The recommended setting for the syrup motor is 85 for thin viscosity shake syrup. For thick viscosity syrup, the syrup motor setting may need to be set higher (100 - 160) if the flow rate is too slow or the amount of syrup measured in the Verification Mode is not within the specified range.

The following screen appears when the Syrup Motor Setup option is selected. (See Figure 78.)

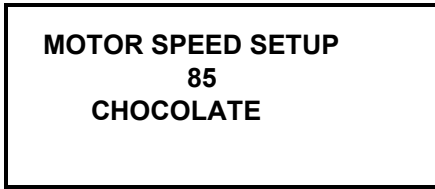





Figure 78

Select the AUTO symbol  to increase the syrup motor setting or the OPTIONAL FLAVOR symbol  to decrease the setting. Select the CALIBRATION symbol  to advance to the next screen.

The second screen in the Syrup Motor Setup option allows the service technician to adjust the reverse time for the syrup pump motor. (See Figure 79.)

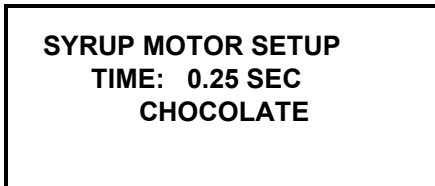

Figure 79



Each peristaltic pump motor must reverse the syrup flow momentarily when the flow is stopped in order to eliminate the pressure in the line and close the duckbill syrup valve. The reverse time setting for most thin viscosity syrups is 0.25 seconds. Thick viscosity syrup may require a slightly longer reverse time setting (0.26 – 0.32).

Examples: (Triple Thick Shake Settings)

FLAVOR	SPEED	REVERSE TIME
Chocolate	160	0.28 - 0.32
Strawberry	140	0.26 - 0.30
Vanilla	85	0.25 - 0.28
Optional	100	0.25 - 0.28

If the reverse time setting is too short, pressure remaining in the line may cause syrup to seep past the duckbill valve after the shake is dispensed. When this occurs, the flavoring will carry-over to the next serving.

If the reverse time setting is too long an air pocket may form in the syrup line connected to the freezer door. An air pocket in the line will delay syrup blending with the frozen mix causing unflavored product to be dispensed in the bottom of the cup.

Select the AUTO symbol  to increase the reverse time setting or the OPTIONAL FLAVOR symbol  to decrease the setting. Select the CALIBRATION symbol  to advance to the motor speed setting screen for the next flavor.

Enter the settings for the remaining flavors in the same manner, then select the CALIBRATION symbol  to return to the Service Menu.

Note: To save the Syrup Motor Setup settings you must advance through the screens for each flavor by selecting the CALIBRATION symbol . Exiting the menu option by any other manner will not save the new settings.

Heat Treatment Cycle

The function of the Heat Treatment Cycle is to raise the temperature of the mix in the freezing cylinder(s) and hopper(s) high enough and quickly enough to destroy bacteria. When this has been accomplished, the temperatures must then be returned to a temperature low enough and quickly enough to retard spoilage.

The Heat Treatment Cycle must be successfully completed at least once every 24 hours or the freezer will automatically lock itself in the STANDBY mode.

Single freezing cylinder operation is now available. The software keeps track of the freezing cylinder(s) "in use". Therefore, the Heat Treatment Cycle can now be performed on only one side, if the other side has not been placed in AUTO or STANDBY since the unit was last brush cleaned.

The Heat Treatment Cycle may be started automatically according to the AUTO HEAT CYCLE TIME.

IMPORTANT: The freezer must be operating in either the STANDBY or AUTO mode before a Heat Treatment Cycle can be started.

There are three phases in a Heat Treatment Cycle: Heat, Hold and Cool.

The Heat Phase

During this phase, the temperatures of the product in the freezing cylinder and hopper are raised over 151.5°F (66°C) in 90 minutes or less.

The Heat Phase Timer "times out" the maximum allowable amount of time the unit can remain in the HEAT phase of the Heat Treatment Cycle. If the timer exceeds 90 minutes, the unit will lock-out.

The Hold Phase

During the HOLD phase, the temperature of the product is "held" over 151.5°F (66°C) for a minimum of 30 minutes to ensure the destruction of all harmful bacteria in the product.

The Hold Phase Timer "times out" 30 minutes as long as all freezing cylinder and hopper temperatures remain above 151.5°F (66°C) for the duration of the HOLD phase.

The Heat Soak Timer prevents the HOLD phase from entering the next COOL phase of the cycle until the 30 minutes is satisfied and until the total time of the HEAT and HOLD cycles combined is greater than 115 minutes.

The Cool Phase

During the COOL phase, the product in the freezing cylinder and the hopper are lowered to 41°F (5°C) or less. The unit must complete this phase in less than 120 minutes.

The COOL Phase Timer measures the maximum allowable time the unit can remain in the COOL phase. If the timer exceeds 120 minutes, the unit will lock-out.

The Heat Cycle TT (Total Time) Timer "times out" the maximum allowable time the unit can remain in the Heat Treatment Cycle (4 hours). If the timer exceeds four hours, the unit will lock-out. This timer is a combination of the HEAT, HOLD, and COOL Phase Times.

When the entire Heat Treatment Cycle has been completed, the normal display will appear, indicating that the machine is operating in the STANDBY mode.

Heat Treatment Graph

During the HEAT and HOLD phases, the glycol is heated by the use of a glycol heater. During the COOL phase, the glycol and freezing cylinder product are refrigerated by the use of the machine's main refrigeration system.

At the start of the HEAT phase the glycol heater begins to overcome the cold freezing cylinder temperature and the glycol temperature raises slowly to 178°F (81°C).

The purpose of the HEAT phase is to raise the product temperature above 150°F (65°C) within 90 minutes. To satisfy the control system, the product must actually reach 151.5°F (66°C). This requirement ensures that the 150°F (65°C) requirement has been met. Health laws require these parameters to be 150°F (65°C) in 90 minutes; however, the actual amount of time the freezer takes to accomplish this requirement is closer to 60 minutes.

Once the HEAT Phase is complete, it is necessary to complete the Heat Soak Timer. From the time the Heat Phase is started, 115 minutes must transpire before the cool phase may enter. Due to the implementation of the Heat Soak Timer, the Heat Cycle Data Screen will now refer to the HOLD phase as the "OVER" phase.

While in the COOL phase, the beater motor and the main refrigeration system operate continuously until the machine first cycles off. For the remainder of the COOL phase, the beater motor and compressor operate from a timed cycle. The timed cycle allows the beater motor to stop for two minutes and then run for six seconds. During the six seconds that the beater motor is on, if the viscosity is below setpoint, the compressor is turned on. When viscosity is satisfied, the compressor and the beater are turned off. The timed cycle continues in this manner until the COOL phase is complete.

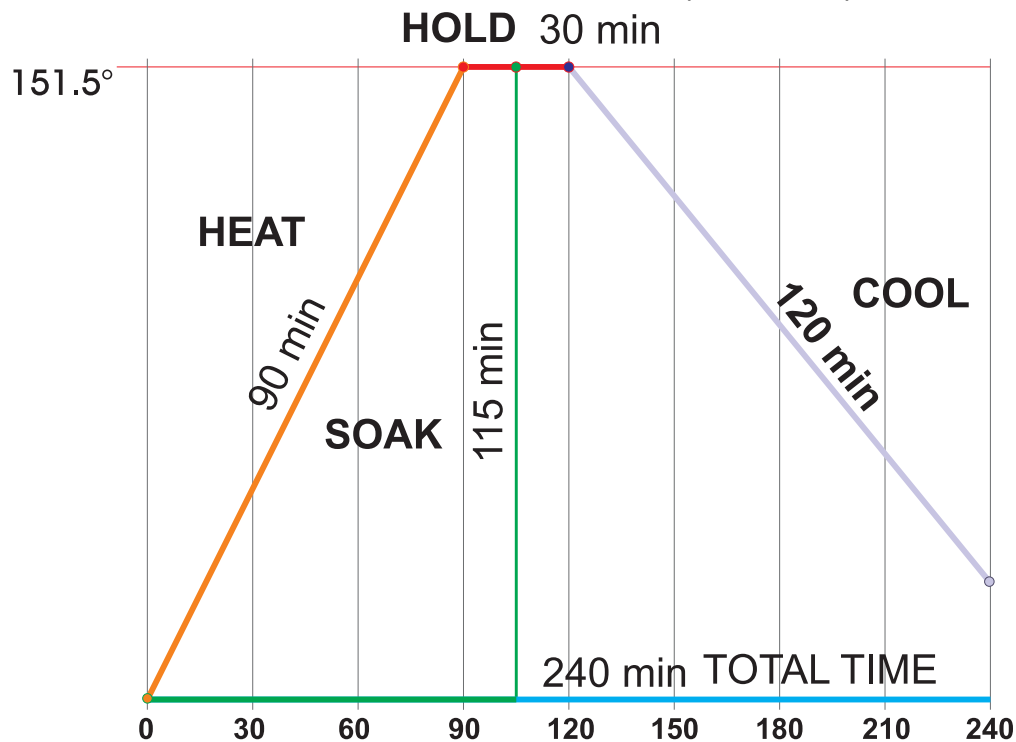

Figure 80

Timers

Two Minute Stir Cycle

If either side of the machine is in the STANDBY mode, the beater motor for that side will turn on for six seconds every two minutes.

If any hopper is above the cut-in temperature, the beater stir cycle timer is activated.

Soft Serve - If the machine is in the HEAT mode, this two minute stir cycle will continue until the freezing cylinder temperature rises above 135°F (57°C). If the machine is in the AUTO mode or the COOL phase of the Heat Treatment Cycle, and the hopper is calling for refrigeration, the beater motor and compressor will continue to run until the viscosity setpoint has been reached.

Shake - If the machine is in the AUTO mode and the hopper is calling for refrigeration, the beater motor will run once every two minutes. If the freezing cylinder product viscosity has been satisfied during this beater run time, the beater motor will turn off. Otherwise, the compressor will also turn on and run until the freezing cylinder product viscosity has been satisfied. During the Heat Treatment Cycle the beater motor runs continuously until viscosity is satisfied in the Cool Phase after which the beater motor will run as in the AUTO mode to cool the hopper.

Glycol Pump Timer

If either side of the machine is operating in the AUTO mode, and the hopper requires refrigeration, the glycol pump will operate one minute, discontinue for two minutes, then operate again for one minute. This pattern continues until hopper refrigeration is no longer required.

Mix Pump Timer

Shake - The mix pump will run for 10 seconds anytime the unit is placed in the AUTO mode, but not from STANDBY.

Soft Serve - The mix pump will run for 30 seconds anytime the unit is placed in the AUTO mode.

Mix Draw Timer (Soft Serve Application Only)

During the AUTO mode, the mix pump will run for 5 - 30 seconds every time product is drawn from the machine. The factory setting is 10 seconds.

Draw Safety Timer (Shake Application Only)

During the AUTO mode, if the pyroelectric sensor has not detected the product level, the safety timer will terminate the draw. The draw safety timer is adjustable from 3 - 60 seconds. The recommended setting is five seconds longer than the time required to dispense the largest serving size (International = 11 seconds, Triple Thick Shake = 24 seconds).

Brush Clean Countdown

The Brush Clean Countdown displays on the control panel. It counts the number of days before the next brush cleaning is required. When the display has counted down to "1", the following message will appear on the VFD screen. (See Figure 81.) The machine must be disassembled and brush cleaned within 24 hours.

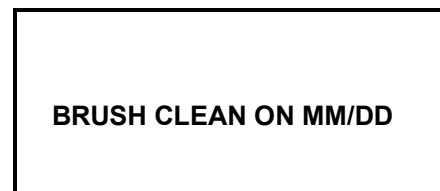

Figure 81

24 Hour Last Heat Cycle Event

If the machine runs longer than 24 hours without a successful Heat Treatment Cycle, the machine will soft lock.

14 Day Timer

If the machine runs longer than 14 days without a successful brush cleaning, the machine will hard lock.

Note: This timer is adjustable from 2 to 14 days.

Heat Phase Timer

The Heat Phase Timer times out the maximum allowable time the unit can be in the Heat Phase of the Heat Treatment Cycle (90 minutes). If the timer exceeds 90 minutes, the unit will lock-out.

Hold Phase Timer

This timer assures that product in the freezing cylinder and the hopper are held above 150°F (65°C) for a minimum of 30 continuous minutes.

Heat Soak Timer

The Heat Soak Timer prevents the HOLD phase from entering the COOL phase until the HOLD phase requirements are met and the total time of the HEAT and HOLD phases is greater than 115 minutes.

Cool Phase Timer

The Cool Phase Timer times out the maximum allowable time the unit can remain in the COOL phase of the Heat Treatment Cycle (120 minutes). If the timer exceeds 120 minutes, the unit will lock out.

Safety Timeout

Once power is applied to the unit, a 60 second timer places the unit in an "IDLE" state. The tone is turned on in 0.5 second intervals, and a "Safety Timeout" message appears on the LCD. This timer can be aborted by pressing any key.

Brush Clean Timer

This timer times out 5 minutes when all conditions for a successful brush cleaning are met.

- a. Mix Low/Mix Out condition
- b. Hopper and barrel temperatures are above 60°F (15.6°C).
- c. Both freezer doors were removed concurrently.

Glycol System

The following information describes the glycol system. For further understanding, see the Glycol Path diagram at the end of this chapter.

The glycol system serves two purposes. During the STANDBY and AUTO modes, the glycol is used to cool the mix hoppers. During the HEAT mode, the glycol is used to heat the mix in the hopper(s) and freezing cylinder(s).

Glycol is a heat transfer medium made up of 50% ethylene glycol and 50% distilled water.

Note: It is factory recommended to drain, flush and re-supply a fresh glycol mixture on a two-year maintenance schedule.

Standby and Auto

During a **refrigeration** mode, the freezing cylinders are cooled using refrigerant, and the product is controlled by viscosity during the AUTO mode and by temperature during the STANDBY mode.

The hoppers are cooled in the following manner:

When a hopper temperature reaches the cut-in point, the glycol pump, solenoid valve, and beater stir cycle are all activated.

The glycol lines go (in order) through the heater, through the solenoid valve, around the freezing cylinder, and then to the hopper. In other words, the glycol is cooled directly by the freezing cylinder walls and is then pumped to the hoppers to cool the mix. Each hopper has one thermistor probe and can function independently.

Note: The heater is OFF during refrigeration modes.

In each hopper, there is an agitator paddle which is used to distribute the heat or cold evenly throughout the mix so the mix does not freeze or burn on the sides of the hopper. It runs continuously when the freezer is in the AUTO, STANDBY or HEAT mode. The agitator is driven by a motor and belt(s).

The Heat Treatment Cycle

During the heating phase the heater is activated. For shake application, beater agitation will continue until the compressor cycles off. For soft serve application, the beater will agitate for six seconds every two minutes until the freezing cylinder product rises above 135°F (57°C).

During the HEAT phase, all refrigeration is cancelled, and the glycol will heat the freezing cylinder(s) and the hopper(s) to the set temperatures.



WARNING: Ethylene glycol is very harmful to your health. Swallowing glycol is fatal. Refer to M.S.D.S. Guidelines.

Note: If the glycol is purchased from the factory, it is pre-mixed and ready to use. Otherwise, glycol should be mixed with distilled water in a ratio of 50% glycol and 50% distilled water.

Installing the Glycol Mixture

Step 1

Attach a hose (capable of depressing the schrader valve) to the 1/4" flare fitting located beneath the accumulator tank. Remove the cap from the accumulator and place the opposite end of the hose into the accumulator tank.

Step 2

Using a pair of pliers, squeeze the tube located between the access fitting and the tube that leads to the bottom of the glycol accumulator tank.

Step 3

Fill the accumulator tank 2/3 full.

Step 4

Remove the necessary panels to expose the shake interface board. Locate the test pins marked, "W2, W3, W4, and W5". Place a two pin jumper on the test pins marked "W4". The jumper will activate the glycol pump and open the glycol solenoids (if applicable). The glycol existing in the accumulator will be pumped through the glycol system.

Step 5

Monitor the level of glycol mixture in the tank and to be sure all air pockets are removed, continue to add more as necessary to maintain a 2/3 full level. Allow the unit to operate for a short period of time. Once the service hose starts to empty glycol back into the accumulator tank, the system is properly filled. Remove the jumper from the pins marked, "W4". Release the pliers.

Step 6

Remove the service hose and replace the cap on the 1/4" flare fitting. Replace the accumulator tank cap.

Step 7

Check for glycol mixture leaks.

Replenishing the Glycol Mixture

Note: If the accumulator tank is empty, follow the steps outlined in "Installing the Glycol Mixture". If the unit needs replenishing, complete the following steps:

Step 1

Remove the cap from the glycol accumulator tank.

Step 2

Replenish the glycol mixture until the tank is 2/3 full.

Step 3

Replace the cap on the accumulator.

Step 4

Check for glycol mixture leaks.

Draining the Glycol Mixture

Step 1

Attach a service hose (capable of depressing the shraeder valve) to the 1/4" access fitting. Allow the opposite end of the hose to rest in an empty bucket.

Step 2

Using a pair of pliers, squeeze the tube located between the access fitting and the tube leading to the bottom of the glycol accumulator tank.

Step 3

Remove the cap from the top of the accumulator tank. The glycol will begin to flow into the bucket.

Step 4

Remove the necessary panels to expose the shake interface board. Locate the test pins marked, "W2, W3, W4, and W5". Place a two pin jumper on the test pins marked, "W4".

Step 5

Once the glycol mixture stops flowing into the bucket, replace the cap on the glycol accumulator tank.

Step 6

Disconnect the outlet line from the glycol pump. Blow air or nitrogen through the outlet line from the glycol pump. This procedure will fully drain the system.

Step 7

Once the system is fully drained, remove the service hose and replace the access cap. Replace the outlet line of the glycol pump to proper position. Remove the pliers.

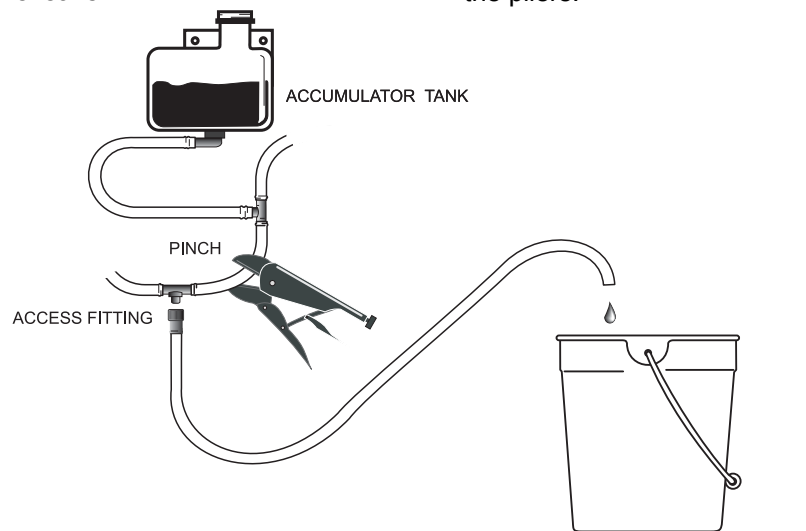

Figure 82

Glycol Path

(Rear View)

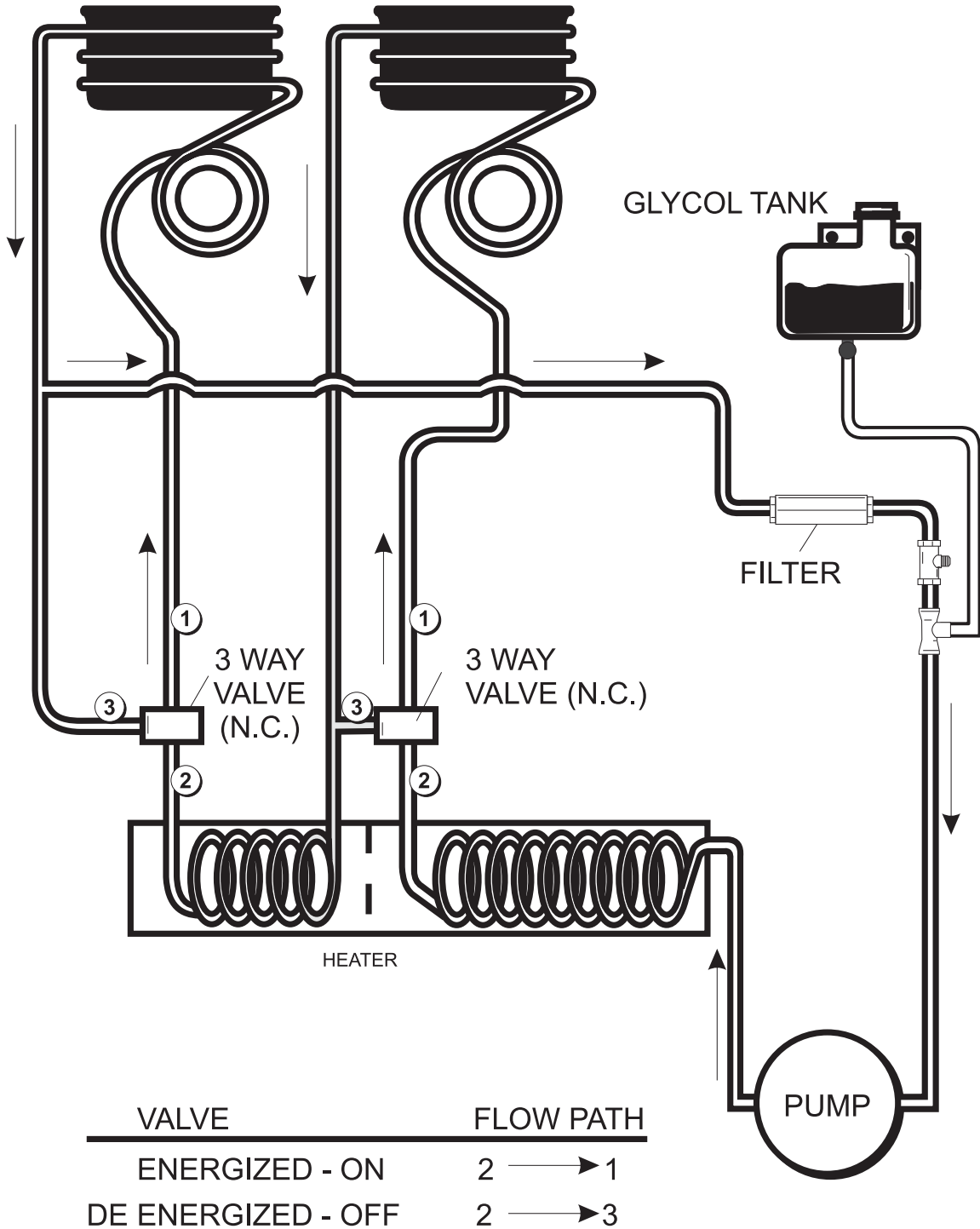

Figure 83

Setting Viscosity

Viscosity

Viscosity is the term used when referring to product appearance, temperature, thickness and firmness.

Note: See page 27 to adjust viscosity settings.

Shake

The shake viscosity is measured by monitoring the gap opening of the beater drive coupling which is mounted on the output shaft of the gear unit. The gear unit turns the spring loaded drive coupling. As the product in the freezing cylinder becomes thicker, the springs collapse, and the size of the gaps change.

As the gaps narrow, the Hedlunds (HD's) increase. As the product thickens (becomes colder) the HD's increase. After achieving a pre-adjusted HD setting, the refrigeration cycle discontinues.

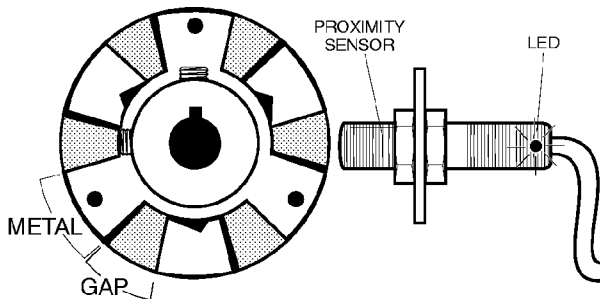

Figure 84

The factory default setting for cycle off viscosity is 4000 HD's. To adjust the serving viscosity, it may be necessary to raise or lower the HD setting. Adjust in increases of 100 HD's at a time. Note: Be sure that the syrups are correctly calibrated before determining the proper serving viscosity.

For standard units, the serving temperature of a flavored shake may range from 24°F to 26°F (-4.4°C to -3.3°C).

For Triple Thick Shake units, the serving temperature may range from 22°F to 24°F (-5.6°C to -4.4°C)

Soft Serve

The soft serve viscosity is measured by monitoring the amperage load of the beater motor. The amperage load of the beater motor is low when the product in the freezing cylinder is liquid. As the product freezes (thickens), the amperage load increases. When the amperage load reaches the setpoint, the refrigeration cycle discontinues.

The factory default setting (setpoint) for soft serve viscosity is 2.8 A. The amperage measurement is determined by monitoring the L1 leg of power being delivered to the beater motor. To adjust the serving viscosity, it may be necessary to raise or lower the amperage setpoint. Adjust in increases of 0.1 amp.

The serving temperature of soft serve product may vary throughout the day. The serving temperature may range from 16°F to 19°F (-8.8°C to -7.2°C).

Portion Control (Shake)

The portion control sensor, located in the cup bracket, is a pyro-electric sensor which responds to temperature changes of any kind. When the draw valve is opened (during the AUTO mode) and the product level in the cup reaches the sensor, it will recognize a temperature change. The control board then automatically closes the draw valve.

Portion Control Operation

The interface board receives 16 VAC from the transformer and converts it to 12 VDC for the personality board.

Auto Mode

If the sensor does not detect the product filling the cup, the control board will automatically close the draw valve after the Draw Safety Time has elapsed. (See Draw Safety Time, page 30.)

Heat Mode

During the heat mode, the flavor keys will not open the draw valve.

Portion Control Troubleshooting

At Personality Board:

Step 1

Verify that the shake personality board is properly connected to the interface board.

Step 2

Verify J3 (RED header) connections:

Pin 3 = WHITE: This is the cup-full signal that goes to the UVC through the interface board. It is normally less than .2 VDC when a cup-full is not sensed, and makes a momentary 5 VDC pulse when a cup-full is sensed.

Pin 2 = BLACK: This is the DC GROUND connection.

Pin 4 = RED: This is the +12 VDC power supply from the interface board.

At Pyro Sensor Board:

Step 1

Verify that the shake personality board is properly connected to the J3 (RED header):

Pin 1 - WHITE: This is the “sense” output of the sensor.

Pin 2 - BLACK: This is the DC GROUND connection.

Pin 3 = GREEN: This is the 2.5 VDC reference output of the sensor.

Pin 4 = RED: This is the +12 VDC power supply for the sensor.

Step 2

Verify that the wiring harness is properly connected on J2:

Pin 1 = 12 VDC

Pin 2 = This is the cup-full signal. It is normally less than .2 VDC when a cup-full is not sensed, and makes a momentary 5 VDC pulse when a cup-full is sensed.

Pin 5 = GROUND

Adjustable Draw Handle

This unit features an adjustable draw handle to provide the best portion control, giving a better, consistent quality to your product and controlling costs. The draw handle should be adjusted to provide a flow rate of 5 to 7-1/2 oz. (142 to 213 g.) of product by weight per 10 seconds. To INCREASE the flow rate, turn the screw CLOCKWISE, and COUNTER- CLOCKWISE to DECREASE the flow rate. (See Figure 85.)

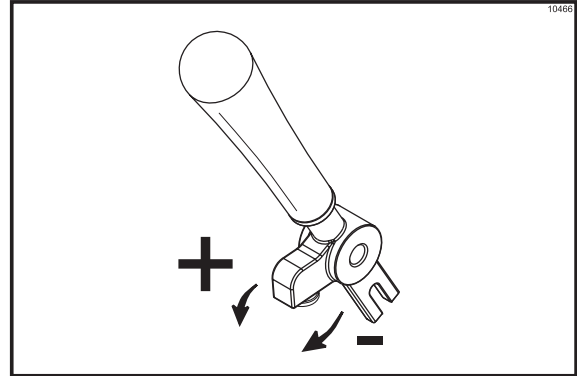

Figure 85

Control Overview

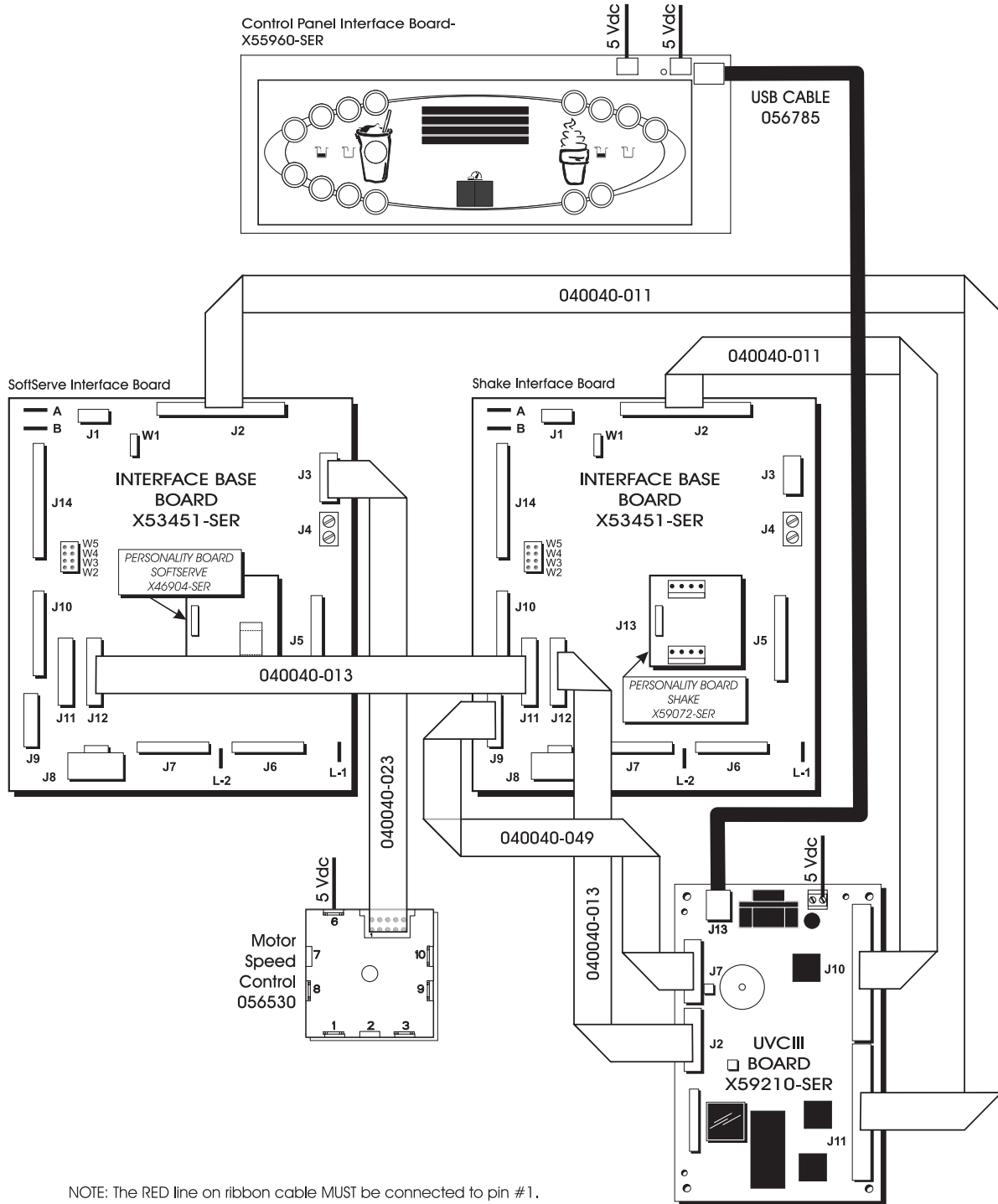
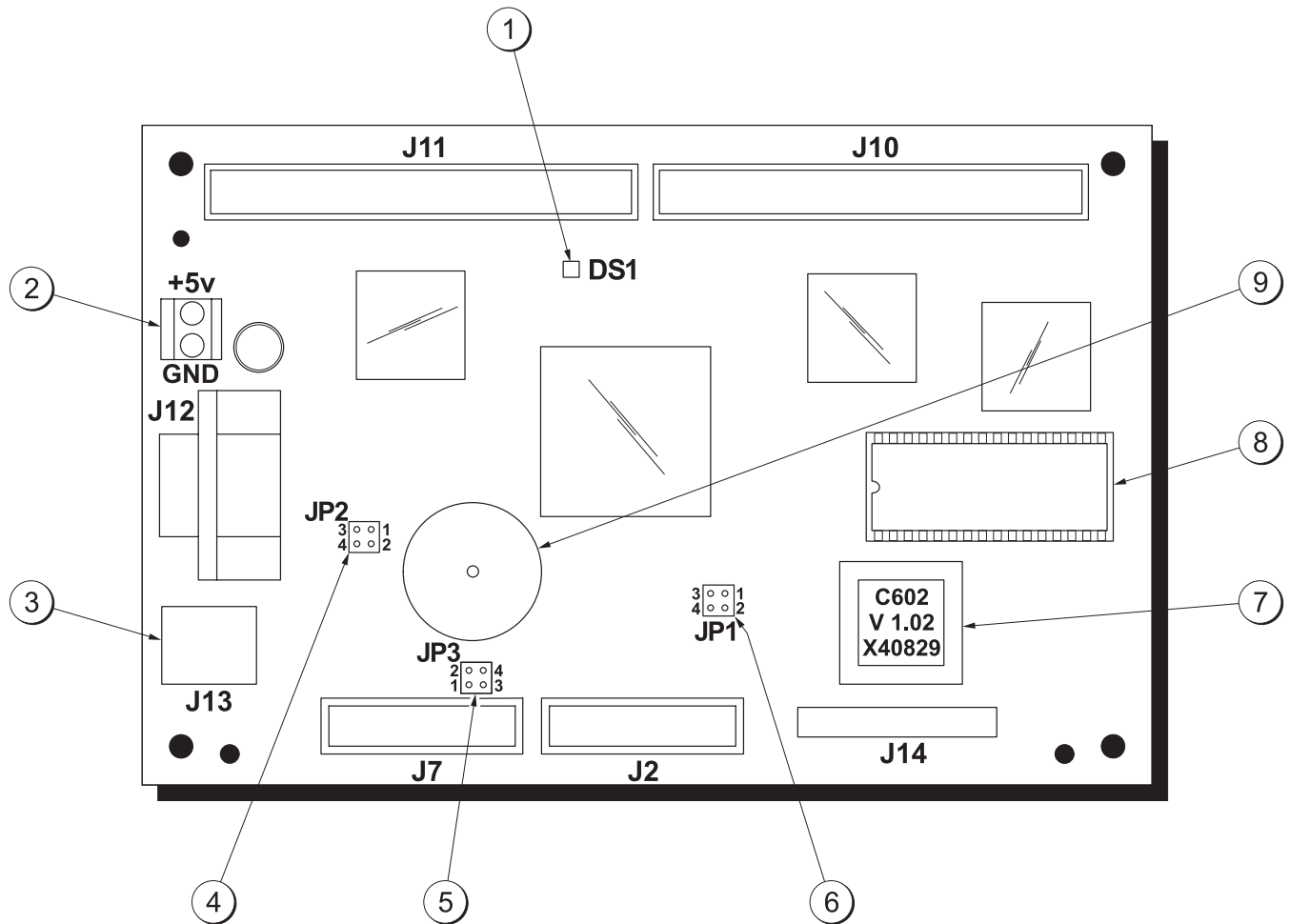

Figure 86

Universal Control (UVC3)



ITEM	DESCRIPTION	FUNCTION
1	LED	When board is powered, LED flashes ON (0.5 sec.) and OFF (0.5 sec.).
2	5 VDC Power Supply	Supplies power to UVC3 Board (Range: 4.75 - 5.25 VDC)
3	USB Cable Connection	Communication to Control Panel Interface Board.
4	JP2 Pins	See table on page 45.
5	JP3 Pins	See table on page 45.
6	JP1 Pins	See table on page 45.
7	EPROM Chip	PLCC Chip-C602 Software Version Number.
8	RAM Chip	Stores program settings from menu in memory.
9	Audible Tone Device	Not activated on Model C602 (See table on page 45.)

Universal Control (UVC3)

The Universal control is the command center for the machine. The software program, including multiple language selections, resides in the EPROM chip. The EPROM is inserted into a socket on the control board. The angled corner on the chip identifies the correct position for installation. A PLCC type extraction tool is needed to remove the chip from the socket.

The settings in the menus are saved in the RAM chip. Removing and reinstalling the RAM chip will restore the factory default settings in the menus. The RAM chip must be inserted with the notch towards the side of the socket with the notch.

Power is supplied to the 5 VDC terminal on the UVC3 board from the interface board. The operating voltage range for the control is 4.75 – 5.25 VDC.

Note: For installations with low voltage supply (210V or less) it may be necessary to wire the 16 VAC transformer on the low voltage tap. Low voltage supplied to the interface board, in turn reduces the voltage supplied to the UVC3 board and may cause intermittent power failure tripping or the control panel keys do not function when the machine is powered.

The UVC3 communicates with the control panel interface board through a USB Cable.

There are three sets of pins on the UVC3 board. Refer to the following chart to identify their function.

Note: Use Part No. 040084-001 CONNECTOR-PROGRAMING SHUNT to jumper pins.

Interface Boards

Both interface boards are the same for the shake and soft serve side. Ribbon cables provide the communication path between the UVC3 and the interface boards.

A 16 VAC transformer supplies the power for the interface boards at Terminals A and B. Each board has a 5 VDC output terminal block. Line voltage is connected to the interface boards (L1 and L2) to operate components in the machine on command.

There are four sets of pins (W2,W3,W4,W5) on each interface board. The pins on the soft serve board are inactive in the Model C602. The pins on the shake interface board function as follows:

- W2 Installing a jumper resets the Brush Clean date when both sides are in the OFF mode.
- W3 If the machine is in the AUTO mode, installing a jumper will simulate the viscosity setpoint.
- W4 Installing a jumper forces the start of the glycol pump and both left and right glycol solenoid are energized.
- W5 If a jumper is present the real time clock can be changed in any mode.

JUMPER	UVC3 PINS	FUNCTION
JP1	Pins 1 & 2	Jumper installed - normal applications using refrigerated mix.
		No jumper installed - general market configuration using non-refrigerated mix. Ignores hopper temperature lockout parameters to allow adding non-refrigerated mix into the hopper.
	Pins 3 & 4	No jumper - Not used (<i>for future development</i>)
JP2	Pins 1 & 2	Domestic configuration - jumper installed. Hopper temperature not displayed on screen. Heat symbol keys are only active when a lockout condition has occurred. Standby keys are disabled.
		International configuration - no jumper. Hopper temperature is displayed on screen. Manual heat cycle starts by selecting HEAT symbol. Standby keys are functional.
	Pins 3 & 4	No jumper - Not used (<i>for future development</i>)
JP3	Pins 1 & 2	Jumper installed - enables audible device located on UVC3 control. Disabled (no jumper) in models that have an audible device on the control panel board.
	Pins 3 & 4	No jumper - Not used (<i>for future development</i>)

Personality Boards

A Personality Board plugs into the interface board. The shake proximity sensor (torque coupling sensor) and the portion control pyro-electric board harness are connected to the shake personality board. The soft serve personality board monitors the amperage in one leg of power supplied to the beater motor.

Control Panel Interface Board

The Control Panel Interface Board (Dec Plate PCB) is fastened to the back of the tempered glass panel and communicates with the UVC3 through a USB cable.

The control panel has two 5 VDC power leads supplied to the board. One connection supplies power to operate the touch sensors and LED's and the other 5 VDC connection provides power to communicate with the UVC3 control.

The Vacuum Fluorescent Display (VFD) plugs into a socket on the interface board. The potentiometer dial at the top of the board is non-functional. The VFD does not require a contrast adjustment.

Pins labeled W1 on the face of the Control Panel Interface Board must have a jumper installed to enable the audible tone when a key is selected. (W1 is located next to the audible tone device, below the 5 VDC connectors.)

The interface board must have the insulator installed to shield the circuitry on the back of the board.

Motor Speed Control

The motor speed control is powered by 5 VDC and receives data bit information through a 10 pin ribbon cable. The speed control transmits a modulated signal to the syrup motor, therefore the voltage cannot be accurately measured with a meter.

The syrup pump motors run at maximum speed in the prime mode.

The UVC3 Control calculates the motor speed setting in the syrup calibration mode and sends the information to the speed control.

Electrical System Modes of Operation Chart

COMPONENT	HEAT			STANDBY	WASH	AUTO	PUMP	PRIME
	Heat	Hold	Cool					
Compressor			X	X		X		
Beater Motor	X	X	X	X	X	X		
Fan			X	X		X		
Spinner Motor (Shake Only)						X		
Air/Mix Pump Motor						X	X	
Syrup Pump						X		
Glycol Heater	X	X						
Agitator	X	X	X	X		X		
Left Glycol Solenoid	X	X	X	X		X		
Right Glycol Solenoid	X	X	X	X		X		
Glycol Pump	X	X	X	X		X		
Shake Draw Solenoid					X	X	X	X

Electrical System - L1 Power Path

Power Cord Plugged In / Power Switch in the OFF Position

L1 power from the power cord connection travels through the EMI filter to the 16 volt transformer. The transformer supplies 16 vac to terminals A and B on the left interface board and right interface board.

The interface boards supply 5 VDC to the Universal Control, Personality Boards, Control Panel Interface Board, and the motor speed control.

Power Switch in the ON Position

L1 power from the power cord connection is supplied to terminal L1 on both interface boards. L1 must travel through the following switches to activate the interface board:

Power switch, beater overload switch, compressor high pressure limit switch, 15A fuse.

Power Switch On / Mode Select: WASH

With L1 power supplied to the L1 terminal on the interface board, the power is then given to terminal J6, pin 7 to supply power through the interlock relay to the beater motor contactor coil.

Power Switch On / Mode Select: PUMP

With L1 power supplied to the L1 terminal on the interface board, power is then given to terminal J6, pin 5 to supply power to the air/mix pump overload and then to the air/mix pump motor.

Power Switch On / Mode Select: AUTO

With L1 power supplied to the L1 terminal on the interface board, power is then given to terminal J6 and directed through the following pins:

Shake Side

7 for the beater motor contactor coil (passes through the beater interlock relay)
5 for the air/mix pump motor (10 seconds only)
4 for the glycol solenoid
2 for the glycol pump motor
1 for the compressor contactor coil.

Soft Serve Side

7 for the beater motor contactor coil (passes through the beater interlock relay)
6 for the agitator motor
5 for the air/mix pump motor (30 seconds only)
4 for the glycol solenoid
3 for the Right Syrup Heater (Heater Mode ON)
2 for the Left Syrup Heater (Heater Mode ON)
1 for the compressor contactor coil.

Until the hopper thermistor probe is satisfied, the glycol pump will operate on a timed cycle.

Power Switch On / Mode Select: AUTO/Draw Initiated

With L1 power supplied to the L1 terminal on the interface board, power is then given to terminal J6 and directed through the following pins:

Both interface boards

7 for the beater motor contactor coil (passes through the beater interlock relay)
6 for the spinner motor (shake side only)
5 for the air/mix pump (The pump runs for 10 seconds after the the draw handle is closed – soft serve only.)
1 for the compressor contactor coil. (Compressor delay start based on COMP ON DELAY setting in the Service Menu.)

Power Switch On / Mode Select: AUTO Heat Cycle Activated

From the terminal marked L1 on the interface board, L1 power is sent to terminal J6 and directed through the following pins:

Shake Side

7 for the beater motor contactor coil (passes through the beater interlock relay)

4 for the left glycol solenoid.

(Operation of the solenoid is controlled by the shake product thermistor probes which are connected to terminal J10.)

3 for the glycol heater relay coil

2 for the glycol pump.

Soft Serve Side

7 for the beater motor contactor coil (after the freezing cylinder has reached 135°F / 57°C).

(Note: Power must go through the beater interlock before reaching the coil.)

6 for the agitator motor

4 for the glycol solenoid

(Operation of this solenoid is controlled by the soft serve glycol thermistor probe which is connected to terminal J10.)

Operation of the glycol heater is controlled by the glycol thermistor probe which is connected to terminal J10 of the shake interface board.

At the completion of the Heat and Hold phases of the Heat Treatment cycle, the glycol heater stops, and the main compressors are activated from terminal J6 pin 1 on the interface boards.

Once the freezing cylinder and hopper thermistor probes (connected to terminal J10 on the interface board) have been satisfied, the Heat Treatment cycle will end.

Shake Draw Sequence Chart

Refer to the following chart for the normal operating sequence when a shake is dispensed in the AUTO Mode.

Sequence	Component		Shake Interface Board	Soft Serve Interface Board
Flavor Symbol Selected in AUTO Mode	Activate	Flavor Selection LED	-	-
	Start	Beater Motor	J6-T7 / J7-T1	-
	Start	Pump Motor	J6-T5 / J7-T2	-
	Start	Spinner Motor	J6-T6 / J7-T1	-
	Start	Syrup Motor	J5-T1 / J5-T2, 4, 5, 6	-
	Energize	Draw Solenoid Pull Relay	-	J5-T7 / J5-T8
	Energize	Draw Solenoid Hold Relay	J5-T7 / J5-T8	-
Dispensing	0.25 Seconds From Start of Draw			
	De-energized	Draw Solenoid Pull Relay	-	J5-T7 / J5-T8
	*2.0 Seconds From Start of Draw			
	Energized	Compressor Contactor Coil	J6-T1 / J7-T7	-
	Activate	Control Monitors Pyro-sensor Voltage (0.1 VDC)		-
Fill Level Detected by Pyro-sensor / or Flavor Symbol Selected	Fill Detected	5 VDC Detected at Personality Board		-
	Start	White Spot Timer	-	-
	Stop	Syrup Pump Motor	J5-T1 / J5-T2, 4, 5, 6	-
	*White Spot Timer Countdown (0.2 - 0.4 Seconds)			
Close Draw Valve & Reverse Syrup Flow	Turn OFF	Flavor Selection LED		
	Stop	Mix Pump Motor	J6-T7 / J7-T2	-
	Stop	Spinner Motor	J6-T6 / J7-T1	-
	De-energized	Draw Solenoid Hold Relay	J5-T7 / J5-T8	-
	Start	Reverse Syrup Motor	-	J5-T1 / J5-T2
	*Syrup Motor Reverse Timer (0.25 - 0.35)			
Viscosity Setting Achieved - Cycle OFF	Stop	Compressor	J6-T1 / J7-T7	-
	Stop	Beater Motor	J6-T7 / J7-T1	-
	Start	Off Cycle Stir Timer	-	-

*Adjustable setting in Service Menu

Syrup Delivery

Shake syrup is stored in the lower front compartment. Each syrup flavor is delivered to the dispensing door by a peristaltic pump. Syrup can be pumped directly from disposable plastic jugs, stainless steel tanks, or adapted to syrup-in-bag dispensing. The proper syrup delivery rate is achieved by calibrating each syrup flavor.

A 24 VDC motor drives each peristaltic pump. In the AUTO mode, the UVC3 control regulates the motor speed necessary to dispense syrup at the calibrated

rate. The pump motors run at maximum speed in the SYRUP PRIME mode.

A relay is used to reverse the rotation of the syrup pump motor each time the pump operation is discontinued. The syrup flow must be momentarily reversed in order to drop the pressure in the line and close the duckbill syrup valve.

Refer to the Motor Setup section in the Service Menu, page 31 for motor and reverse time settings.

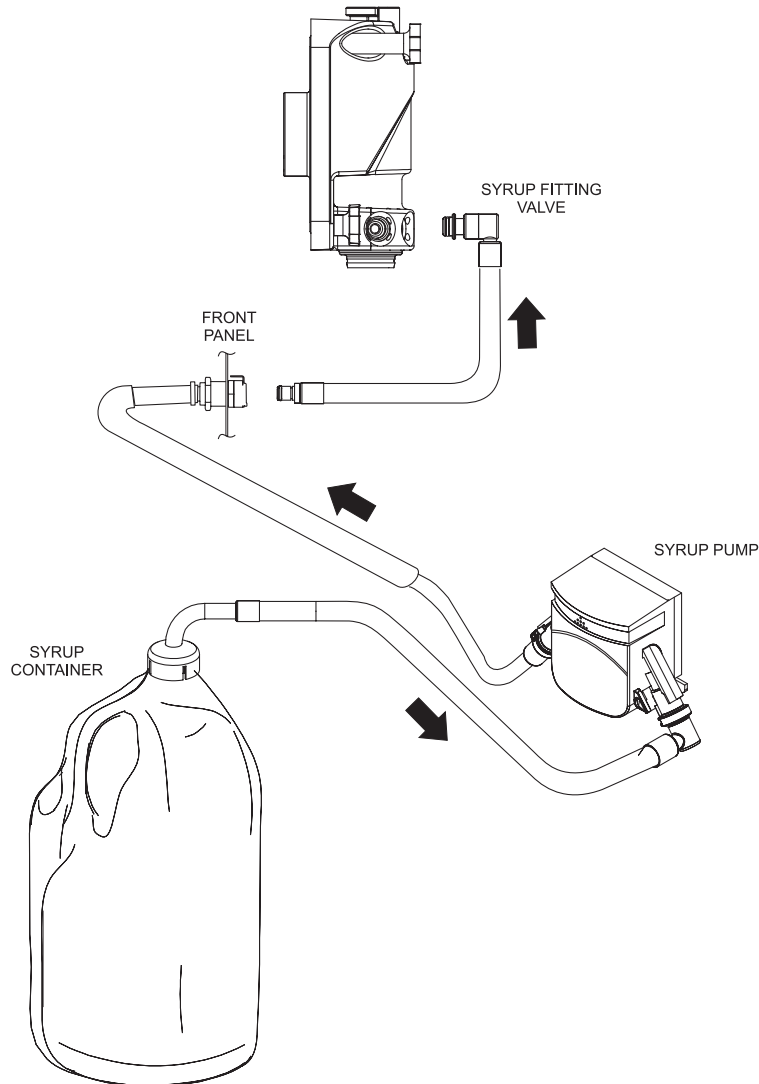

Figure 87

Syrup Calibration





Calibrating the syrup flow should be performed weekly when the syrup system is cleaned. It is vital that the correct amount of syrup be incorporated into the frozen mix to obtain a quality shake.

To determine the rate of syrup flow, you will need a calibration cup indicating fluid ounces. The proper rate of syrup flow is 1 fl. oz. (30 ml) of syrup in 5 seconds. For Triple Thick Shake syrups, the proper syrup flow rate is 1 fl. oz. +/- 1/8 fl. oz. (30 ml +/- 4 ml) in 7 seconds. Once this rate is set, the correct amount of syrup will be blended with the shake base regardless of the size of shake served. Please note that syrup calibration is critical when changing the promotional 4th flavor syrup.

Calibration Procedure

Syrup lines must be properly primed with syrup to eliminate air in the line before the calibration procedure is performed.

Step 1

Touch the CALIBRATION symbol  to display the menu options. The CALIBRATION symbol , the AUTO symbol  on the Shake side, and the OPTIONAL FLAVOR symbol  will be illuminated. (See Figure 88.)

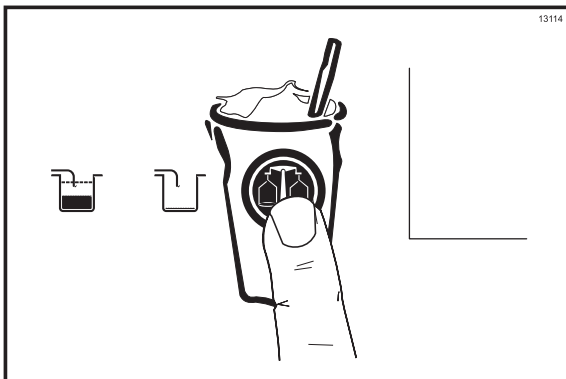

Figure 88

The screen will display the calibration menu options. (See Figure 89.)

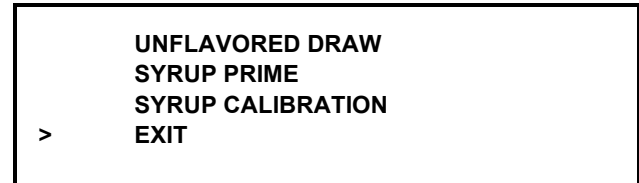





Figure 89

Note: When the CALIBRATION screen is displayed, the flavor selection symbols  will not raise the draw valve to dispense shake product.

Step 2

Touch the AUTO symbol  or the OPTIONAL FLAVOR symbol  to scroll the arrow to SYRUP CALIBRATION. (See Figure 90.)

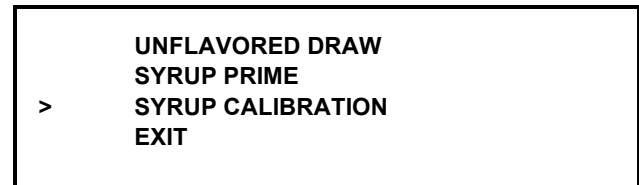



Figure 90

Step 3

Touch the CALIBRATION symbol  to enter the syrup calibration mode. (See Figure 91.)

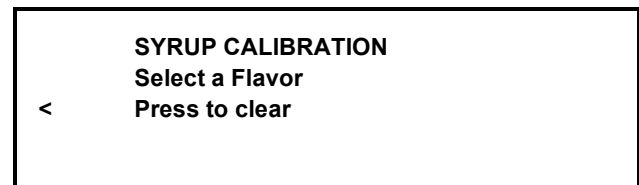

Figure 91

Step 4

Disconnect the syrup valve from the freezer door. Raise the syrup valve retainer and pull the valve straight out. (See Figure 92.)

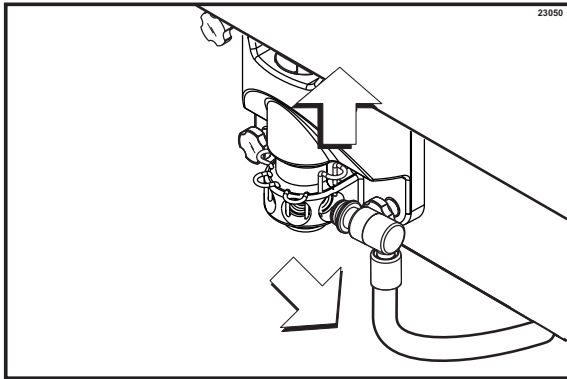



Figure 92

Step 5

To calibrate the syrup dispensing rate, hold the small portion of the calibration cup under the valve for the flavor to be calibrated. Touch the corresponding FLAVOR SELECT symbol  to activate the syrup pump and start the flow of syrup. When the syrup level measures one ounce, touch the same FLAVOR SELECT symbol  to stop the syrup flow.

Verify the level of syrup in the cup. If the measurement is not within the specification, repeat step 4 for the same flavor until the correct syrup calibration is achieved. (See Figure 93.)

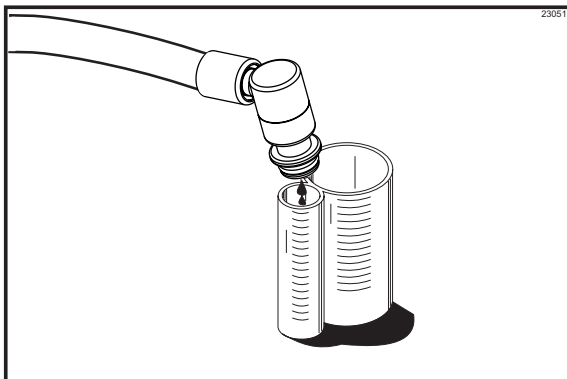

Figure 93

Note: You can verify the syrup dispensing rate in the Manager's Menu or the Service Menu.



Repeat steps 4 and 5 for the remaining syrup flavors.

If the calibration time exceeds the maximum motor speed the "CAN'T CALIBRATE" message will appear on the screen. (See Figure 94.) For additional information see "Peristaltic Syrup System Troubleshooting" on page 64.



Figure 94

Step 6

Exit the CALIBRATION mode by touching the CALIBRATION symbol . A blank screen will appear and the AUTO symbol  and the OPTIONAL FLAVOR symbol  will return to their normal function.

Note: Whenever a particular syrup line is not used, the syrup hole plug found in the spare parts kit must be installed. Place the syrup hole plug o-ring into the groove of the syrup hole plug, and lubricate. Install the hole plug in the door. Lower the retaining pin to secure the plug in place.

Shake Dispensing Alignment Procedure

There are five areas that must be properly aligned in the shake draw mechanism.

- Actuator Plate
- Spinner Motor Bracket
- Solenoid Valve
- Spinner Motor
- Spinner Coupling

All adjustments must be performed with the freezer door assembled and installed, with the hand screws secure. Tighten the hand screws in a criss-cross pattern so the door is drawn up flush on the cylinder face. (See Figure 95.)

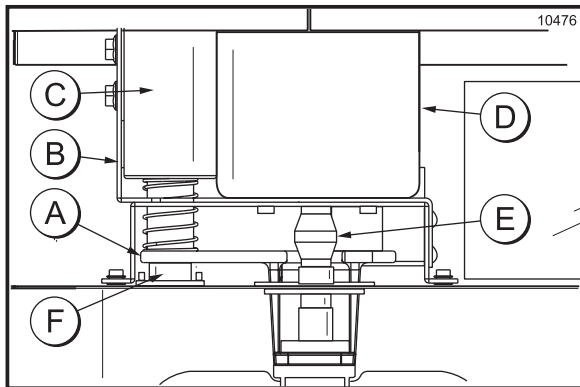

Figure 95

ITEM	DESCRIPTION
A	ACTUATOR PLATE
B	SPINNER MOTOR BRACKET
C	SOLENOID VALVE
D	SPINNER MOTOR
E	SPINNER COUPLING
F	BUMPER

Actuator Plate

The actuator plate (lifter) should be centered to fit in the draw valve slot. (See Figure 96.)

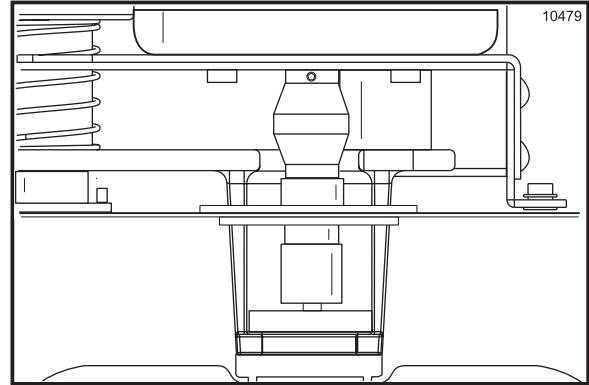

Figure 96

To adjust the alignment, perform the following steps:

Step 1

With the bumper access plate removed and the bumper screw loose, align the actuator with the slot in the draw valve (side to side alignment).

Step 2

Secure the bumper screw. Check to make sure the bottom of the solenoid plunger is secured to the actuator plate.

The actuator should slide easily into the draw valve slot when the freezer door assembly is installed. (See Figure 97.)

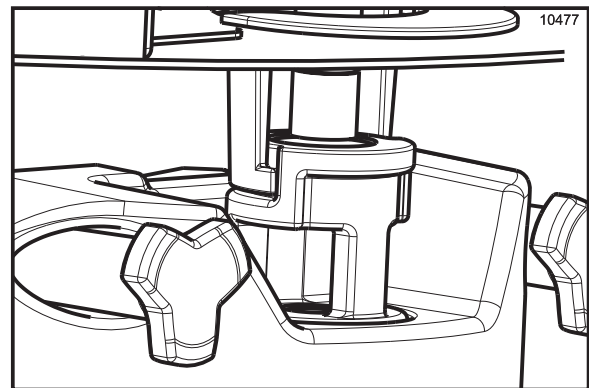

Figure 97

Spinner Motor Bracket

The actuator plate should ride gently against the rear guide post.

The guide post is mounted underneath the spinner motor bracket. (See Figure 98.) Moving the bracket forward brings the guide post forward. When properly aligned, the actuator should move freely without any tension on the guide post.

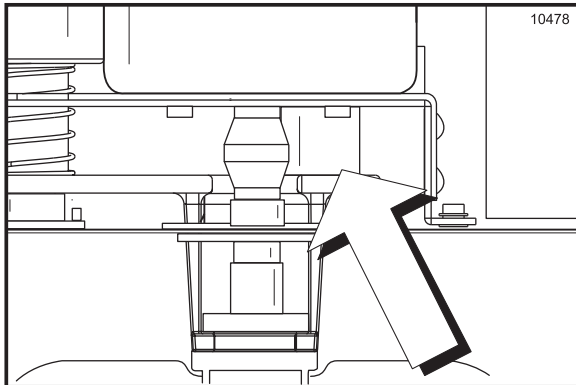

Figure 98

To adjust the alignment, perform the following steps:

Step 1

Loosen the four hex head screws that secure the spinner motor bracket to the control channel bracket.

Step 2

Slide the bracket forward or backward to the correct position and secure the four screws.

Solenoid Valve

The solenoid valve should be vertically aligned so the plunger moves freely in the coil without side load. The height of the solenoid should be adjusted to raise the draw valve to the top of the product port in the freezer door.

With the spinner blade and the driven spinner removed, and the draw valve in the raised position, look inside the freezer door. The bottom of the draw valve should be located at the top of the product entry port.

If the valve is too high or too low, the height of the solenoid will need adjustment.

To adjust the solenoid height, use the Solenoid Adjust Tool Kit Assembly (X59702) and perform the following steps:

Step 1

Place the power switch to the OFF position and disconnect power to the machine.



Make sure the power switch is in the OFF position. Failure to follow this instruction may result in severe personal injury from hazardous moving parts.

Step 2

Remove the front control panel.

Step 3

Loosen the two 7/16" nuts that secure the draw solenoid to the mounting bracket. The solenoid spring tension will push the coil to the top of the adjustment slots in the bracket.

Step 4

Remove the restrictor cap, spinner blade, and the driven spinner from the shake door.

Step 5

Rinse the area below the draw valve.

Step 6

Lubricate the two o-rings and install the Solenoid Adjust Tool into the door spout. Lift the draw valve to insert the tool into the door. Install the restrictor cap to retain the tool with the draw valve in the raised position. (See Figure 99.)

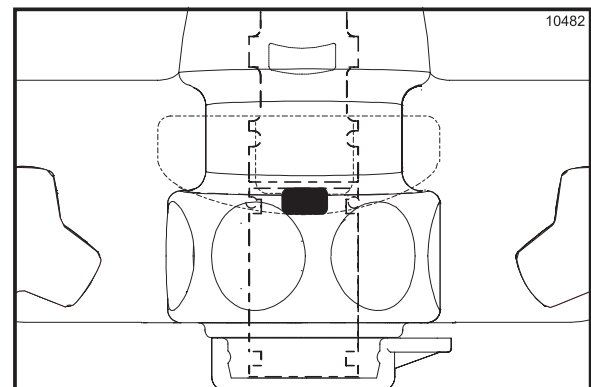

Figure 99

Step 7

Lower the solenoid until the top of the plunger contacts the top surface (stopping point) inside the coil body. (See Figure 100.) Make sure the solenoid is aligned vertically and then retighten the two 7/16" nuts to secure the solenoid.

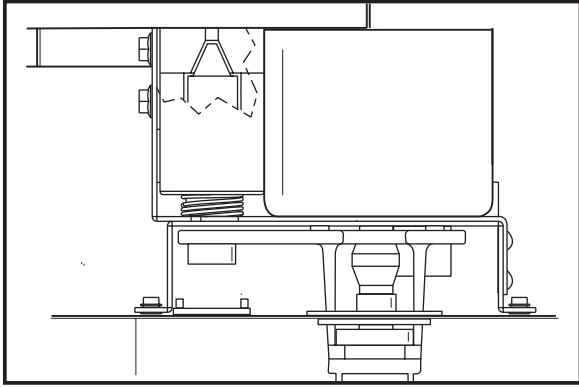

Figure 100

Step 8

Remove the restrictor cap and tool.

Step 9

Sanitize, lubricate, and reinstall the driven spinner and spinner blade. Install the restrictor cap.

Step 10

Install the front control panel and restore power to the machine.

Step 11

Dispense several shakes to check for proper draw valve performance.

Spinner Motor

The spinner motor shaft must be centered in the draw valve. The spinner blade shaft must insert into the center of the spinner coupling. (See Figure 101.)

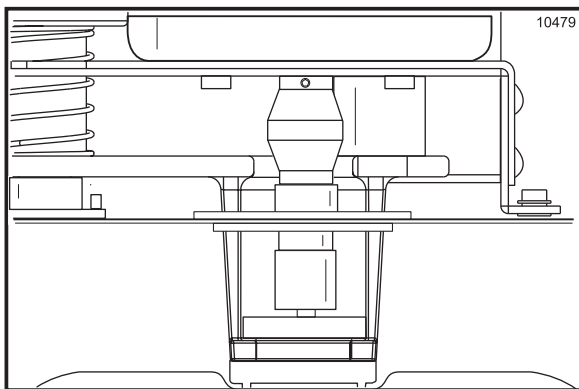

Figure 101

To adjust the alignment, perform the following steps:

Step 1

Loosen the four screws that secure the spinner motor to the bracket. With the freezer door assembly installed, insert the spinner blade into the coupling.

Step 2

Position the motor so the spinner shaft is centered with the coupling.

Step 3

Tighten the two front screws.

Step 4

Remove the door to tighten the rear screws.

Spinner Coupling

The coupling must be adjusted so the spinner blade is recessed 1/32" (0.8 mm) or less in the bottom of the door spout.

To adjust the alignment, perform the following steps:

Step 1

Assemble the freezer door.

Step 2

Loosen the top screw that secures the coupling to the spinner motor shaft.

Step 3

Position the coupling so the bottom of the spinner is recessed 1/32" (0.8 mm) or less in the bottom of the door spout.

Step 4

Retighten the coupling screw.

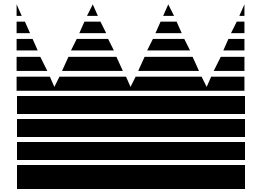

Section 3: Troubleshooting

- **General Troubleshooting**
- **Air/Mix Pump System Troubleshooting**
- **Peristaltic Syrup System Troubleshooting**
- **Shake Dispensing Mechanism Troubleshooting**
- **Shake Portion Control Troubleshooting**
- **Bacteria Troubleshooting**

General Troubleshooting Guide

PROBLEM	CAUSE	REMEDY
1. Compressor will not run.	<ul style="list-style-type: none"> d. The power switch is in the OFF position. e. An incorrect key was pressed. f. The contactor is faulty. g. The compressor has burned out. h. The fuse or circuit breaker has blown. i. Tripped overload (compressor). j. Off on reset (beater motor). 	<ul style="list-style-type: none"> a. Place the switch in the ON position. b. Press the correct key for AUTO operation. c. Replace the contactor. d. Replace the compressor. e. Replace the fuse, or turn on the breaker. f. Place the power switch in the OFF position, and allow the compressor to cool and the overload to close before returning the power switch to the ON position. g. Press the reset button.
2. Unit operates long (cycles off on the 11 minute safety timer).	<ul style="list-style-type: none"> a. Condenser is dirty. b. Air filter is dirty. c. Shortage of refrigerant. d. Air in the system. e. High overrun product. 	<ul style="list-style-type: none"> a. Clean the condenser. b. Replace the air filter. c. Repair the leak and recharge unit. d. Purge and recharge the system. e. Check pump operation for correct air/mix ratio.
3. Head pressure is too high.	<ul style="list-style-type: none"> a. Condenser is dirty. b. Air filter is dirty. c. Water valve is out of adjustment or is restricted. d. Insufficient air space around unit. e. Refrigerant overcharge. f. Blower is faulty. g. The air deflector is not properly installed, recirculating warm air into the condenser. 	<ul style="list-style-type: none"> a. Clean the condenser. b. Replace the air filter. c. Check the adjustment and the water supply. d. Make sure there is sufficient air space surrounding the unit (see "Specifications"). e. Correct the refrigerant charge. f. Replace the blower. g. Properly install the air deflector.
4. Head pressure is too low.	<ul style="list-style-type: none"> a. Refrigerant shortage. 	<ul style="list-style-type: none"> a. Repair leak and recharge.
5. Liquid line is hot.	<ul style="list-style-type: none"> a. Shortage of refrigerant. 	<ul style="list-style-type: none"> a. Repair leak and recharge.
6. Leaking door spout.	<ul style="list-style-type: none"> a. Improper lubrication. b. Worn or nicked o-ring. 	<ul style="list-style-type: none"> a. Lubricate according to instructions in the operator's manual. b. Replace the o-ring.

General Troubleshooting (Cont'd.)

PROBLEM	CAUSE	REMEDY
7. Excessive mix leakage through the rear of the unit into the drip pan.	<ul style="list-style-type: none"> a. Worn or missing drive shaft seal. b. Inadequate lubrication. c. Drive shaft rotates forward. 	<ul style="list-style-type: none"> a. If worn, nicked or missing, replace the drive shaft seal. b. Lubricate properly. c. Check gear alignment.
8. Low overrun.	<ul style="list-style-type: none"> a. Bad scraper blades. b. Faulty air/mix pump components. c. Restricted air intake (air/mix pump). d. Incorrect syrup calibration (shake). e. Long ON cycles. f. Product flow is restricted in shake door. 	<ul style="list-style-type: none"> a. Replace scraper blades. b. Inspect air/mix pump components and replace those found faulty. c. Clear restriction. d. Calibrate syrup delivery for one ounce every 5 seconds. e. See problem #2. f. See Shake Dispensing Mechanism Troubleshooting on page 67.
9. Draw valve leaking.	<ul style="list-style-type: none"> a. Worn or missing draw valve o-rings. b. Inadequate lube on draw valve o-rings. c. Wrong type of lubricate being used. 	<ul style="list-style-type: none"> a. Replace regularly. b. Lubricate properly. c. Use proper lubricant. Example: Taylor Lube High Performance.
10. Product is not being fed into the freezing cylinder.	<ul style="list-style-type: none"> a. Inadequate mix in the hopper (Mix Out light is illuminated). b. Mix pump motor tripped reset. c. Air/mix pump incorrectly assembled. d. Mix feed tube not installed or incorrectly assembled. 	<ul style="list-style-type: none"> a. Fill hopper with mix. b. Press the reset button. c. Assemble pump according to instructions in the Operator's Manual. d. Assemble and install the feed tube according to the instructions in the Operator Manual.
11. No product being dispensed with draw valve open and machine in the AUTO mode.	<ul style="list-style-type: none"> a. Plugged door spout. b. Beater rotating counterclockwise. c. Inadequate mix in the hopper (Mix Out light is illuminated). d. Pump motor tripped reset. e. Draw valve does not raise high enough to open the product port in the freezer door. 	<ul style="list-style-type: none"> a. Break down the machine and dislodge the door spout clog. b. Correct beater rotation to clockwise. c. Fill hopper with mix. d. Press the reset button. e. See Shake Dispensing Mechanism Troubleshooting on page 67.

General Troubleshooting (Cont'd.)

PROBLEM	CAUSE	REMEDY
12. Product viscosity is too soft or thin.	<ul style="list-style-type: none"> a. Not enough air space surrounding unit. b. Bad scraper blades. c. Dirty air-cooled condenser or air filter. d. Outdated mix. e. Refrigerant shortage. f. Product viscosity set too warm. g. Broken springs in the drive coupling (shake only). 	<ul style="list-style-type: none"> a. Allow 3" (76 mm) minimum clearance around unit. Allow 7-1/2" floor clearance. b. Replace scraper blades. c. Clean condenser, replace air filter. d. Use fresh mix. e. Locate leak and repair. f. Adjust product viscosity. g. Replace broken springs.
13. Plugged door spout.	<ul style="list-style-type: none"> a. Poor scraping. b. Damaged draw valve o-rings. c. Damaged beater assembly. d. Worn rear shell bearing. 	<ul style="list-style-type: none"> a. Replace scraper blades. b. Replace o-rings. c. Inspect and replace if necessary. d. Inspect and replace if necessary.
14. No freezer operation when placing unit in any mode of operation.	<ul style="list-style-type: none"> a. Unit unplugged. b. Circuit breaker is turned off or fuse is blown. c. Power switch is in the OFF position. 	<ul style="list-style-type: none"> a. Plug in unit. b. Turn on circuit breaker or replace fuse. c. Place power switch in the ON position.
15. Product too stiff.	<ul style="list-style-type: none"> a. Product viscosity set too cold. b. Incorrectly assembled or malfunctioning air/mix pump. c. Improperly primed freezing cylinder. 	<ul style="list-style-type: none"> a. Adjust product viscosity. b. Re-assemble pump or replace faulty components. c. Follow priming procedures according to the Operator's Manual.
16. Mix in the hopper is too cold.	<ul style="list-style-type: none"> a. Temperature is out of adjustment. 	<ul style="list-style-type: none"> a. Adjust hopper temperature.
17. Mix in the hopper is too warm.	<ul style="list-style-type: none"> a. Temperature is out of adjustment. b. Agitator not installed. c. Low glycol level. d. Mixture of glycol. 	<ul style="list-style-type: none"> a. Adjust hopper temperature. b. Install the agitator. c. Replenish the glycol. d. Replenish the glycol (50% glycol, 50% distilled water).
18. Drive shaft is stuck in the gear box coupling.	<ul style="list-style-type: none"> a. Corners of the drive shaft, coupling, or both are rounded. b. Mix and lubricant are collected in the drive coupling. 	<ul style="list-style-type: none"> a. Replace the necessary component(s). Do not lubricate the end of the drive shaft. b. Brush clean the rear shell bearing area regularly.

General Troubleshooting (Cont'd.)

PROBLEM	CAUSE	REMEDY
19. Freezing cylinder walls are scored.	<ul style="list-style-type: none"> a. Bent beater assembly. b. Missing or worn front bearing. c. Scraper blades incorrectly installed. 	<ul style="list-style-type: none"> a. Replace beater. b. Install or replace front bearing. c. Install scraper blades over the appropriate securing pin on the beater assembly.
20. Although freezer was brush cleaned, all four LED's are flashing.	<ul style="list-style-type: none"> a. Power switch was not in the OFF position for a minimum of five minutes. 	<ul style="list-style-type: none"> a. When the "Clean Manual" and "H.T. Cycle" LED's stop flashing, the freezer will be unlocked.
21. Product is "popping" when drawn.	<ul style="list-style-type: none"> a. Draw rate set too fast. b. Pump is assembled/lubed incorrectly. c. Faulty component in mix pump. d. Freezer has been turned on and off several times. 	<ul style="list-style-type: none"> a. Set the draw rate at 5 - 7-1/2 oz. (142 - 213 g) of product per 10 seconds. b. Assemble pump according to instructions in the Operator's Manual. c. Inspect/replace faulty pump components. d. Place the unit in the OFF position only when necessary.
22. Freezer shuts off and produces a fault tone.	<ul style="list-style-type: none"> a. Fault alert. b. Insufficient air space. 	<ul style="list-style-type: none"> a. Check the fault screen in the Manager's menu. b. Provide 3" (76 mm) air space around sides.
23. Syrup flows constantly or not at all (difficult calibration).	<ul style="list-style-type: none"> a. Clogged syrup lines. 	<ul style="list-style-type: none"> a. Flush syrup lines with warm water weekly.
24. Mix entering the syrup line.	<ul style="list-style-type: none"> a. Defective duckbill valve in the syrup fitting. b. An empty syrup line is attached to the freezer door. 	<ul style="list-style-type: none"> a. Replace the duckbill valve. b. Remove the syrup line from the door when the line is not in use. Install a hole plug in the freezer door.
25. Soft lock.	<ul style="list-style-type: none"> a. No heat cycle tried. 	<ul style="list-style-type: none"> a. Press the HEAT symbol to place the freezer in the heat treatment cycle, or select the WASH symbol and brush clean the freezer.
26. When the AUTO key is selected the freezer goes into STANDBY.	<ul style="list-style-type: none"> a. Mix-out condition. b. Freezer lock condition. 	<ul style="list-style-type: none"> a. Add mix. b. Check display screen for instructions.
27. Unit changes modes or shuts itself off.	<ul style="list-style-type: none"> a. Faulty connections or components. b. Inadequate voltage supply to the Universal Control. 	<ul style="list-style-type: none"> a. Replace faulty components. b. Check/correct voltage supply to the control (4.75 - 5.75 VDC).

General Troubleshooting (Cont'd.)

PROBLEM	CAUSE	REMEDY
28. "Compressor on too long" fault message.	<ul style="list-style-type: none"> a. Inadequate pump operation. b. Draw rate set too fast. c. Inadequate air flow. d. Faulty blower baffle. e. Inadequate AXV settings. 	<ul style="list-style-type: none"> a. Check pump operation. Assemble pump according to instructions in the operator's manual. b. Set the draw rate at 5 - 7-1/2 oz. (142 213 g) of product per 10 seconds. c. Provide 3" (76 mm) air space around sides. d. Repair or replace blower baffle. e. Set AXV at proper setting. (See "Running Specifications".)
29. Symbol selection is delayed.	a. Defective dec plate.	a. Replace dec plate.

Air Mix Pump System Troubleshooting

PROBLEM	PROBABLE CAUSE	REMEDY
1. Air/mix pump will not operate in the AUTO mode when the draw valve is opened.	<ul style="list-style-type: none"> a. Pump drive is out on reset. b. Malfunctioning interface board. c. Faulty pump motor. d. Faulty connection or draw switch. 	<ul style="list-style-type: none"> a. Allow the unit to cool and press the reset button. b. Replace interface board. c. Replace motor. d. Check connections or replace switch.
2. Piston travels back and forth, but the product is not being pumped.	<ul style="list-style-type: none"> a. Gasket was installed incorrectly, fits loosely, has holes, or was lubricated. b. O-rings are worn, torn or fit too loosely. c. Piston and valve body cap must be assembled correctly and fit snugly in the pump cylinder. d. Missing or defective check ring. 	<ul style="list-style-type: none"> a. Inspect gasket. b. Inspect o-rings. c. Check the pump cylinder for proper assembly and position. d. Replace the check ring.
3. Excessive pump cylinder wear.	<ul style="list-style-type: none"> a. Inadequate or incorrect lubrication of the pump cylinder. b. Ball crank rotates clockwise. 	<ul style="list-style-type: none"> a. Lubricate properly. b. Rewire the ball crank rotation to rotate counterclockwise.
4. Too much pressure in the freezing cylinder.	<ul style="list-style-type: none"> a. Plugged relief hole in the feed tube. 	<ul style="list-style-type: none"> a. Clean the relief hole in the feed tube.
5. Not enough pressure in the freezing cylinder.	<ul style="list-style-type: none"> a. Weak, damaged or missing check ring. b. Malfunctioning draw switch. 	<ul style="list-style-type: none"> a. Replace or install the check ring. b. Reposition or replace the microswitch.
6. One pump cannot be assembled.	<ul style="list-style-type: none"> a. Soft serve and shake pump parts are mixed up. 	<ul style="list-style-type: none"> a. Consult the operator's manual for correct pump assembly combinations.

Peristaltic Syrup System Troubleshooting Guide

PROBLEM	CAUSE	REMEDY
1. No syrup dispensed.	<ul style="list-style-type: none"> a. Air in the syrup line. b. The syrup dispensing rate is not properly calibrated. c. The syrup pump motor is not running. d. A peristaltic pump component is defective. e. Obstruction in the syrup line. f. Obstruction in syrup nose fitting. g. A valve was left in the door during the heat cycle. h. The pump motor is running in the wrong direction. i. Defective motor speed control. j. Loose wire connection. 	<ul style="list-style-type: none"> a. Prime the syrup line. b. Calibrate the syrup. c. Check for faulty connections or a defective motor. d. Inspect/replace defective peristaltic pump component. e. Clean or replace the syrup line. f. Clear the obstruction. g. Clean the syrup valve. h. Check/correct the pump motor wiring. i. Replace the motor speed control. j. Inspect/repair loose connection.
2. Syrup leaking at the valve.	<ul style="list-style-type: none"> a. Air in the syrup line. b. The duckbill valve is defective. c. The pump motor reverse time is set too low. d. The reverse relay does not reverse the pump motor rotation when the syrup flow is stopped. 	<ul style="list-style-type: none"> a. Prime the syrup line. b. Replace the duckbill valve. c. Adjust the pump motor reverse time in the Syrup Motor Setup menu. d. Check the syrup reverse relay voltage supply. (Relay is energized to reverse the pump motor rotation.)
3. Air is in the syrup line.	<ul style="list-style-type: none"> a. The syrup line is improperly primed. b. The pump tube fitting o-rings are defective or not lubricated. c. The pump motor reverse time is set too long. d. Air leak on the intake side of the syrup line/pick up tube. 	<ul style="list-style-type: none"> a. Re-prime the syrup line. b. Replace/lubricate pump tube o-rings. c. Adjust the pump motor reverse time in the Syrup Motor Setup menu. d. Check the line for air leaks and repair it.

Peristaltic Syrup System Troubleshooting (Cont'd.)

PROBLEM	CAUSE	REMEDY
4. Flavor carry-over.	<ul style="list-style-type: none"> a. There is air in the syrup line. b. The Whitespot Setting is incorrect. c. The pump motor reverse time is set too low. d. The reverse relay does not reverse the pump motor rotation when the syrup flow is stopped. e. The duckbill valve is defective. f. The draw solenoid does not keep the draw valve raised. 	<ul style="list-style-type: none"> a. Prime the syrup line. b. Adjust the Whitespot Setting in the Service Menu. Recommended setting: 0.1 - 0.2 for standard shakes and 0.4 for Triple Thick Shakes. c. Adjust the pump motor reverse time in the Syrup Motor Setup menu. d. Check the syrup reverse relay voltage supply. (The relay is energized to reverse the pump motor rotation.) e. Replace the duckbill valve. f. See Shake Dispensing Mechanism Troubleshooting on page 67.
5. Shake is not blended correctly.	<ul style="list-style-type: none"> a. The spinner height is set too low. b. Shake temperature is set too cold / is too thick. c. Syrup calibration is not in specification. 	<ul style="list-style-type: none"> a. Adjust to 1/32" inside the door spout. b. Correct the temperature of a finished chocolate shake: Standard shake = 24-26°F (4.4 - 3.3°C). Triple Thick Shake = 22.5°F (-5.8°C). c. Calibrate the syrup.
6. Unable to calibrate the syrup within specification.	<ul style="list-style-type: none"> a. The weekly syrup line cleaning was not performed. b. The pump tube is worn. c. There's an obstruction in the syrup line. d. The syrup is too cold. e. There is an air leak on the intake side of the syrup line/pick up tube. f. Incorrect Syrup Calibration Setting. g. The syrup fills the cup too fast to accurately calibrate. 	<ul style="list-style-type: none"> a. Clean and sanitize the syrup lines. b. Replace the tube. c. Clean out and replace the line if necessary. d. Stage the syrups near the machine. e. Find the leak and repair/replace. f. Adjust the Syrup Cal setting in the Service menu: 5.0 seconds for standard shakes and 7.0 seconds for Triple Thick Shakes. g. Adjust the motor speed setting slower in the Syrup Motor Setup menu.

Peristaltic Syrup System Troubleshooting (Cont'd.)

PROBLEM	CAUSE	REMEDY
8. Mix backs up in the syrup line.	<ul style="list-style-type: none"> a. Syrup line and/or syrup container is empty. b. The duckbill valve in the syrup fitting is defective. c. An empty syrup line is attached to the freezer door. d. The shake temperature is too cold. 	<ul style="list-style-type: none"> a. Replace the syrup container and prime the syrup line. b. Replace the duckbill valve. c. Remove the syrup line from the door when the line is not in use. Install a hole plug in the freezer door. d. The correct temperature of a finished chocolate shake is 22.5°F (-5.8°C).

Shake Dispensing Mechanism Troubleshooting

PROBLEM	CAUSE	REMEDY
1. Draw valve will not open.	<ul style="list-style-type: none"> a. Power switch is off. b. The solenoid bumper screw is disengaged. c. The draw valve is binding in the freezer door. d. The draw solenoid is adjusted too high. e. The solenoid fuse has blown. f. Loose wire connection. g. Defective rectifier board. h. Defective pull or hold relay. i. Defective solenoid. j. Defective interface board. k. Defective touch key on the dec plate. 	<ul style="list-style-type: none"> a. Place the power switch in the ON position. b. Align the actuator plate and secure the bumper screw to the solenoid plunger. c. Replace defective component. d. Adjust the draw solenoid to the proper height. (See page 55.) e. Inspect/replace the 15A fuse located in the front control channel. f. Check the circuit for power interruption and repair it. g. Replace the rectifier board. h. Replace defective relay. i. Replace the solenoid. j. Replace the interface board. k. Replace the dec plate.
2. Occasionally the draw valve does not open.	<ul style="list-style-type: none"> a. The dispensing mechanism is out of alignment. b. Improper lubrication of the draw valve. c. Incorrect o-rings installed on the draw valve. d. The draw valve is binding in the freezer door. 	<ul style="list-style-type: none"> a. Realign the dispensing mechanism. (See page 54.) b. Lubricate according to instructions in the Operator's Manual. c. Install correct o-rings - part no. 020571-1 (F treated). d. Replace defective component.
3. Draw valve opens momentarily.	<ul style="list-style-type: none"> a. The draw valve solenoid is adjusted too high. b. The portion control system is terminating the draw after two seconds. c. The draw safety time is set too low. d. Defective hold relay. e. Loose wire connection in the draw solenoid circuit. 	<ul style="list-style-type: none"> a. Adjust the draw solenoid to the proper height. (See page 55.) b. See Portion Control Troubleshooting on page 69. c. Adjust the draw safety time in the Service Menu. d. Replace the relay. e. Check the circuit for power interruption and repair it.

Shake Dispensing Mechanism Troubleshooting (Cont'd.)

PROBLEM	CAUSE	REMEDY
4. Draw valve does not fully open (long draw time).	<ul style="list-style-type: none"> a. The solenoid bumper screw is loose. b. The draw solenoid is adjusted too high. 	<ul style="list-style-type: none"> a. Align the actuator plate and secure the bumper screw to the solenoid plunger. b. Adjust the draw solenoid to the proper height. (See page 55.)
5. Draw valve will not close.	<ul style="list-style-type: none"> a. The freezer door is improperly installed. b. Improper lubrication of draw valve. c. Improper o-rings installed on the draw valve. d. The dispensing mechanism is out of alignment. e. The draw valve is binding in the freezer door. f. The solenoid plunger is binding in the coil body. 	<ul style="list-style-type: none"> a. Re-install the freezer door. Tighten the hand screws in a criss-cross pattern. b. Lubricate according to instructions in the Operator's Manual. c. Install the correct o-rings - part no. 020571-1 (F treated) d. Re-align the dispensing mechanism. (See page 54.) e. Replace the defective component. f. Replace the solenoid.

Shake Portion Control Troubleshooting

PROBLEM	CAUSE	REMEDY
1. Under-fills the shake cup.	<ul style="list-style-type: none"> a. The fill level adjustment screw is set too low. b. The portion control sensor lens is dirty. c. The cup holder is not properly positioned to fill the center of the cup. d. The shake cup is moving downward as the cup fills with product. e. The syrup calibration is set too high. f. Loose wire connection. g. Defective pyrosensor. h. Defective pyrosensor board. i. Defective shake personality board. 	<ul style="list-style-type: none"> a. Adjust the fill level screw. b. Clean the lens. c. Position the cup holder properly on the sensor box. d. Place the cup with the cup lip resting on the holder clips. e. Calibrate the syrup. f. Check/repair loose connection in circuit. g. Replace the pyrosensor. h. Replace the pyrosensor board. i. Replace the shake personality board.
2. Over-fills the shake cup.	<ul style="list-style-type: none"> a. The fill level adjustment screw is set too high. b. The viscosity of the shake is too thick, causing the product to stack in the center of the cup. c. The syrup calibration is set too low. d. The portion control sensor lens is dirty. 	<ul style="list-style-type: none"> a. Adjust the fill level screw. b. Check that the product temperature and overrun are within specification. c. Calibrate the syrup. d. Clean the lens.

Bacteria Troubleshooting

Periodic product sampling is taken by a sanitarian. Bacteria counts should not exceed the following figures:

Standard Plate Count (SPC) . . . 50,000
 Coliform 10

If the counts exceed the numbers listed, steps should be taken to locate the cause. Failure to solve the high counts will result in an unsafe product for

consumption. Educate the operator about how to prevent high bacteria counts.

Note: High bacteria counts in soft serve *yogurt* is normal and necessary. Coliform, however, cannot be accepted in any product. The following information will help solve high coliform count problems.

If sample results indicate a problem, one of these areas may be a source of contamination.

CAUSE OF CONTAMINATION	PREVENTION
1. Human contamination.	a. Wash hands and arms past elbows. b. Wear rubber gloves if cuts or skin conditions exist. c. Wash hands periodically throughout the day.
2. Residue product deposits on mix contact surfaces (milkstone build-up).	a. Provide the proper brushes. b. Brush clean all parts and components thoroughly. Ignoring this will allow formation of milkstone, a porous substance which will house bacteria and can lead to contamination of fresh mix.
3. Worn, damaged, or cracked parts.	a. Provide a food grade lubricant (Example: Taylor Lube). b. Inspect o-rings for holes or tears. O-rings, seals and other wear items must be supplied by the freezer company to meet food industry standards. c. During the operating hours, periodically inspect the rear drip pan for excessive leakage.

Bacteria Troubleshooting (Cont'd.)

CAUSE OF CONTAMINATION	PREVENTION
<p>4. Improper cleaning and sanitation procedures.</p>	<ul style="list-style-type: none"> a. For cleaning procedures, scrub the sink and strainers thoroughly before each use. The level of solution in each basin must allow the largest component to be submerged. Sanitize and prime the freezer prior to freezing the product. After sanitizing a freezer, use fresh mix to flush remaining sanitizer from the freezing cylinder. b. Provide the proper brushes, lubricants, and single service towels. c. Store sanitizer in a cool, dry place. Use chemicals according to their labels. d. Use a few good employees to follow the cleaning procedure correctly and consistently. Allow the employee uninterrupted time to complete the cleaning procedure. e. Hold sanitizing solution in the hopper and the freezing cylinder for five minutes. f. Wash and sanitize the tube of lubricant; after each use, always recap the tube. g. Parts, components, and brushes should be air-dried overnight. Never store the equipment in the storage cooler. h. Do not neglect daily cleaning practices: wipe the external areas of the freezer periodically throughout the day, remove the design caps and sanitize the area, check the drip trays and splash shield.
<p>5. Mix stored improperly.</p>	<ul style="list-style-type: none"> a. Rotate stock to use older date code mix first. Shelf life of mix is normally 10 days. b. Mix must never be stacked outside or under direct sunlight while waiting to be placed in the cooler. c. Place the mix directly in the cooler. Always leave one inch between the mix and other products to allow air to circulate around the product. d. Mix must not remain at room temperature for long periods of time. e. Hopper storage must maintain a temperature of 40°F (4.4°C). Storage temperatures above 45°F will allow cell division in as little as one hour. f. Once the mix is placed in the hopper, covers must be properly installed to maintain adequate refrigeration and to prevent airborne contaminants from entering the mix.

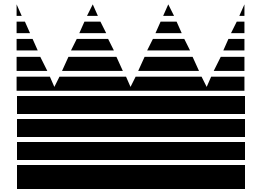

Section 4: Parts

- **Warranty Explanation**
- **Parts Identification**
- **Parts List**
- **Wiring Diagrams**

Warranty Explanation

- Class 103 Parts:** The warranty for new equipment parts is one year from the original date of unit installation, with a replacement parts warranty of three months.
- Class 212 Parts:** The warranty for new equipment parts is two years from the original date of unit installation, with a replacement parts warranty of twelve months.
- Class 512 Parts:** The warranty for new equipment parts is five years from the original date of unit installation, with a replacement parts warranty of twelve months.
- Class 000 Parts:** Wear Items - no warranty.

CAUTION: Warranty is valid only if required service work is provided by an Authorized Taylor Service Technician.

NOTE: Taylor reserves the right to deny warranty claims on equipment or parts if a non-approved refrigerant was installed in the machine, system modifications were performed beyond factory recommendations, or it is determined that the failure was caused by neglect or abuse.

Main Exploded View

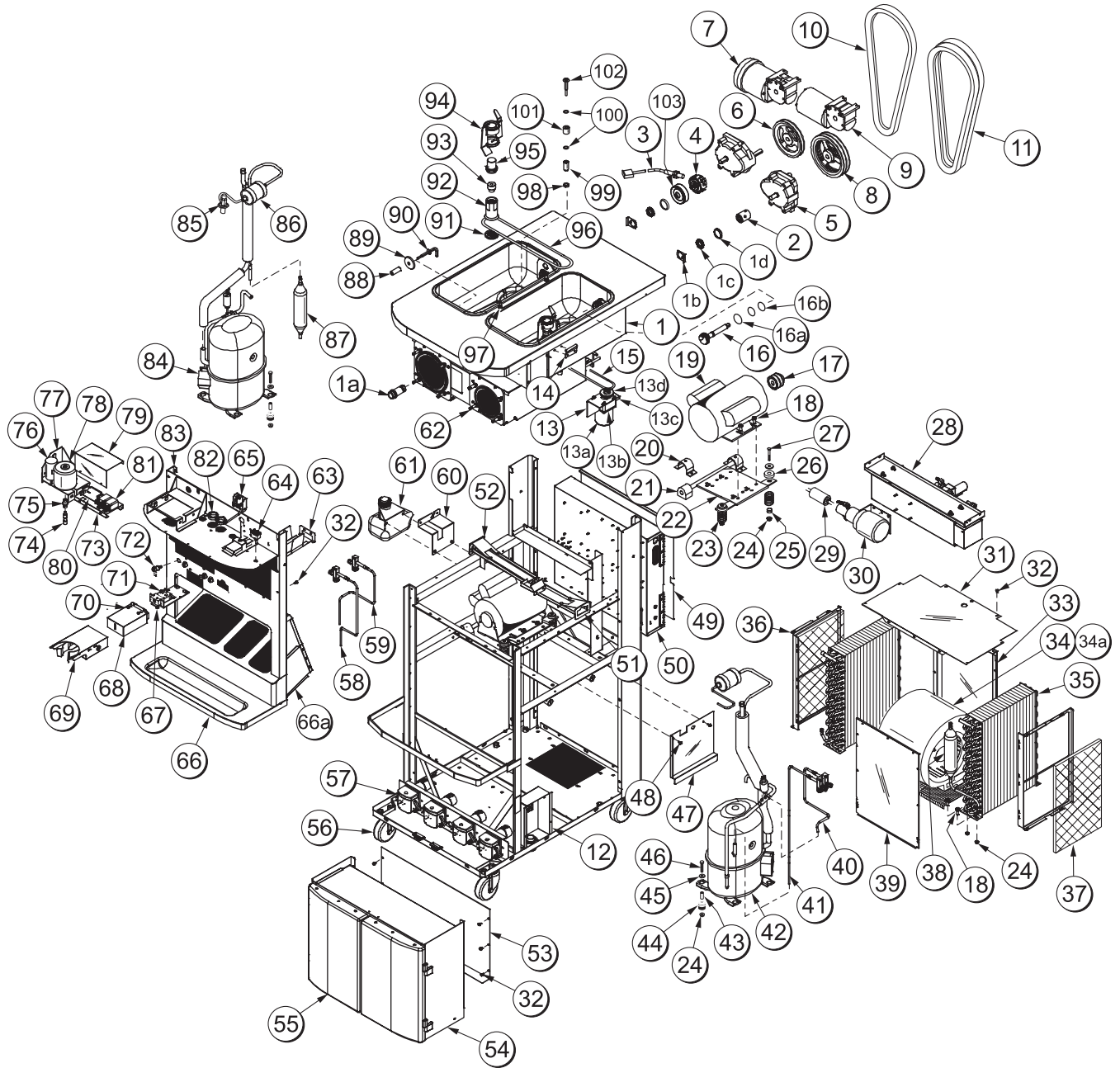

Figure 102

Main Exploded View Parts List

ITEM	DESCRIPTION	PART NO.
1	SHELL A.-INSULATED	X55976
1a	BEARING-REAR SHELL	031324
1b	WASHER-BEARING LOCK	012864
1c	NUT-BRASS BEARING	028991
1d	GUIDE-DRIP SEAL	028992
2	COUPLING-DRIVE 3/4 HEX	012721
3	SENSOR A.-EVC	X44951
4	COUPLING A.-TORQUE-SHAK	X54722
5	GEAR A.*REDUCER 4.21:1	021286-SER
6	PULLEY-AK64-5/8	007538
7	MOTOR-REDUCER 108RPM	044723-27S
8	PULLEY-2AK74-5/8	027822
9	MOTOR-REDUCER 32 RPM	036955-34S
10	BELT-AX31	041575
11	BELT-AX33	024396
12	BOX-SPLICE	056677
*	COVER-SPLICE BOX	056678
13	MOTOR A.-AGITATOR	X55971-27
13a	MOTOR-AGITATOR	047987-27
13b	GEAR A.-REDUCER-AGITATOR	047988
13c	BRACKET-MOTOR-AGITATOR	056184
13d	PULLEY-AGT MTR-1.910 PD	042063
14	CLIP-PANEL*RIGHT	056424
15	BELT-AGITATOR 3/16	055933
16	SHAFT A.-DRIVE-MIX PUMP	X41947
16a	O-RING-1-3/4 OD X .139W	008904
16b	O-RING 1/2 ID X .139W	048632
17	PULLEY-2AK22 x .625*LEFT	016403
	PULLEY-AK25-5/8*RIGHT	019153
18	SCREW-5/16-18 X 7/8 HEX CAP	017973
19	MOTOR-1.0 HP*LEFT	013102-33
	MOTOR-1.5 HP*RIGHT	021522-33
20	CLAMP-MOUNTING	012257
21	BUSHING-RUBBER MOUNT	012258
22	HINGE A.-MOTOR*RIGHT	X25731
	HINGE A.-MOTOR*LEFT	X25736
23	SPRING-COMP .970 X .115	025707
24	NUT-5/16-18 MF LOCK	017327
25	GROMMET-7/16 X 5/16 SHOCK	016212
26	CAP-RUBBER MOUNT	011844

ITEM	DESCRIPTION	PART NO.
27	SCREW-5/16-18 X 3-1/4 STL	022678
	SCREW-5/16-18 X 2-1/2 HEX	002498
28	HEATER A.-GLYCOL 4500	X55965-27
29	FILTER A.-GLYCOL	X47323
30	PUMP A.-GLYCOL	X56162-27G
31	SHROUD-TOP	056504
32	SCREW-10X3/8TYPEB-HWH	015582
33	SHROUD-REAR	055943
34	BLOWER A.	X53725-27
34a	SCREEN-BLOWER	053729
35	CONDENSER-AC 12LX18HX3.12T-5*LEFT	055813-1
	CONDENSER-AC 12LX18HX3.12T-5*RIGHT	055813-2
36	GUIDE-FILTER	053784
37	FILTER-AIR-18.00LX13.50HX.70	052779-3
38	RECEIVER A.-REFRIG-R	X56125
39	SHROUD-FRONT	055944
40	LINE A.-ACCESS-HIGH-LEFT	X56130
41	LINE A.-ACCESS-LOW-RIGHT	X56159
42	COMPRESSOR AHA2490ZXF-AH556R	047519-33F
43	SLEEVE-MOUNTING-COMP.	039924
44	GROMMET-COMPRESSOR MT	039923
45	WASHER-5/16-FLAT ZP STEEL	000651
46	SCREW-5/16-18X1-3/4 HEX	019691
47	GUARD-CORD	056792
48	SCREW-10-24X1/2 TAPTITE	002077
49	COVER-CONTROL BOX	056532
50	CONTROL A.	X55966-33
51	GUIDE A.-DRIP PAN*RIGHT	X55982
52	GUIDE A.-DRIP PAN*LEFT	X55983
53	PANEL-SYRUP PANEL-BACK	056387
54	CABINET A.-ULT SYRUP	X55984
55	DOOR A.-CABINET	X58607
56	CASTER-4" SWV 3/4-10 STM	044106
57	PUMP A.-ULTIMATE SYRUP	X56015
58	LINE A.-ACCESS-LOW-LEFT	X56160
59	LINE A.-ACCESS-HIGH-LEFT	X56130
60	BRACKET-TANK-GLYCOL	047585
61	TANK-GLYCOL 1.5QT-PLASTIC	047314

*NOT SHOWN

Main Exploded View Parts List (Cont'd.)

ITEM	DESCRIPTION	PART NO.
62	STUD-NOSE CONE	055987
63	GUIDE A.-DRIP PAN CENTER	X55972
64	SWITCH-TOGGLE-DPDT	024295
65	SWITCH A.-DRAW	X33322
66	PANEL A.-FRONT	X55981
66a	RAIL A.-SYRUP	X56287
67	HOLDER A.-SENSOR-ADJ	X55980
68	PLATE A.-MOUNT-PORT.	X55978
69	HOLDER-CUP-SHAKE-3.906	056008
70	SCREW-10-32 X 1/2 TRUSS HD	037734
71	PCB A.-PYRO	X59073-SER
72	FITTING-PANEL MT QD .250 ID	056674
73	BRACKET-RECTIFIER	059481
74	COUPLING A.-DRIVE-SPINNER	X20329
75	COUPLING-FLEXIBLE W/SCR	020108
76	SOLENOID-DRAW VALVE-SH	059462
77	MOUNT A.-SPINNER	X57905
78	MOTOR A.-SPINNER W/PLUG	X35584-27
79	GUARD-RECTIFIER	059482
80	PCB A.-DUAL BRIDGE RECTIF	X59290-SER
81	RELAY-DPDT 20A-12VDC	077164-02
82	BUSHING-SNAP 1-5/16 ID	017008
83	CHANNEL A.-CONTROL	X55975
84	COMPRESSOR AHA7513ZXF-AH245R	047520-33F

ITEM	DESCRIPTION	PART NO.
85	VALVE-EXP-AUTO-1/4S X 1/4	046365
86	DRYER-FILTER-HP62-3/8 X 1/4	048901
87	RECEIVER A.-REFRIG-L-AC	X56124
88	SPACER-PROBE *SQ HOLE*	030966
89	DISC-PROBE *SQ HOLE*	030965
90	PROBE A.-MIX LOW-HT	X42077
91	PULLEY-AGT DR-1.910PDX5/16	036210
92	HOUSING A.-AGITATOR *LONG	X51661
	HOUSING A.-AGITATOR *SHORT	X51664
93	MAGNET A.-AGITATOR-INNER	X41733
94	AGITATOR	036059
95	CAP-MAGNET	044796
96	BELT-AGITATOR	056017
97	PIN-RETAINING-HOPPER CVR	043934
98	NUT-10-32 HEX	005598
99	SPACER-PROBE-SQ HOLE-7/8	041346
100	O-RING-1/2 OD X .070W	024278
101	SPACER-PROBE-ROUND	041347
102	PROBE A.-MIX OUT-SQ HOLE	X41348
103	DEFLECTOR-TORQUE CPLG	054698

*NOT SHOWN

Syrup Cabinet View

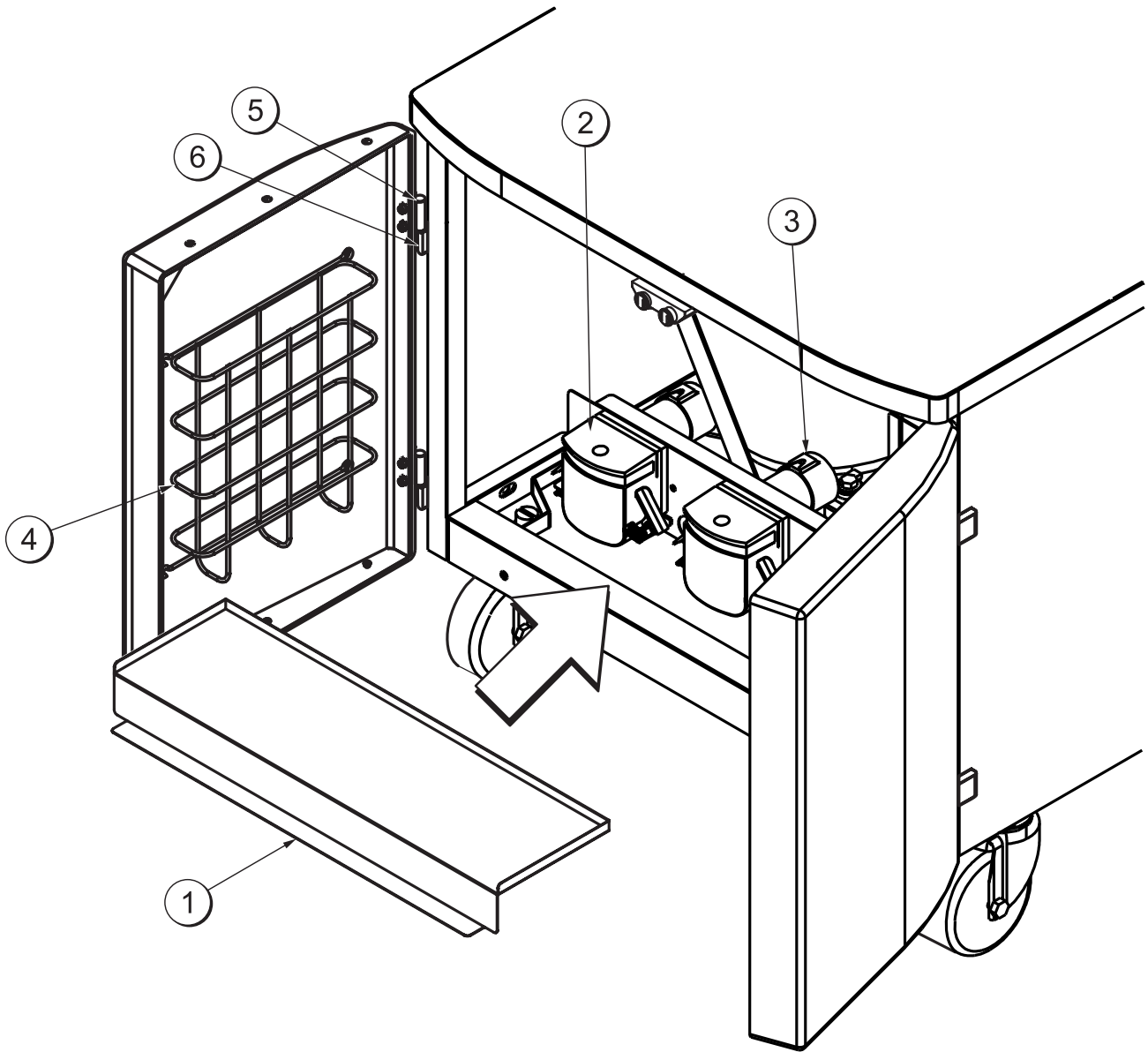

Figure 103

ITEM	DESCRIPTION	PART NO.
1	SHELF-SYRUP	056016
2	PUMP-PERISTALTIC	052916
3	MOTOR-GEAR 161 RPM	058725
4	RACK-SYRUP CABINET DOOR	059144

ITEM	DESCRIPTION	PART NO.
5	BLOCK-HINGE	058613
6	BLOCK-HINGE	058614
*	PIN-HINGE	058615

*NOT SHOWN

Mix Pump & Tubes

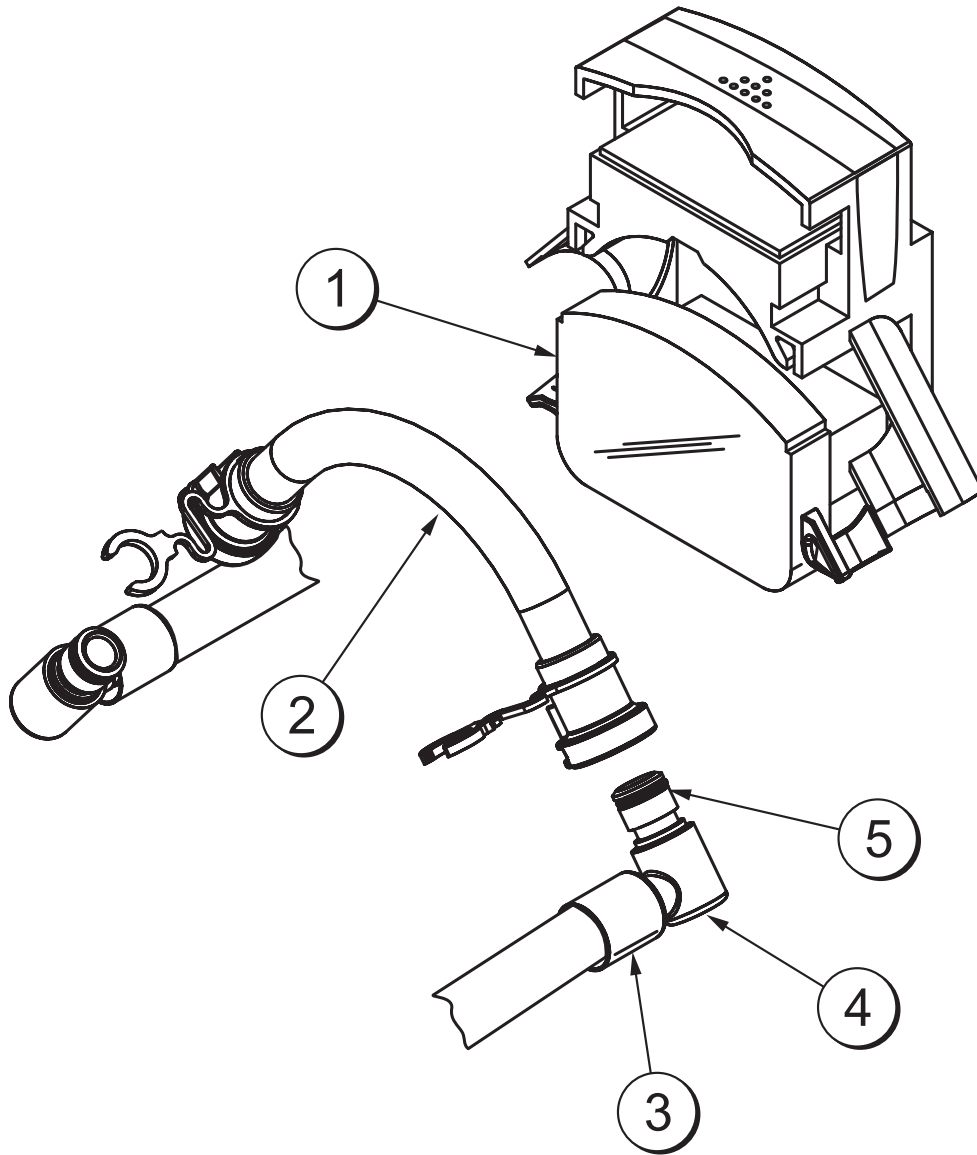

Figure 104

ITEM	DESCRIPTION	PART NO.
1	PUMP-PERISTALTIC	052916
2	KIT A.-PERISTALTIC PUMP TUBE	X54978
3	FERRULE-.625 ID	053036

ITEM	DESCRIPTION	PART NO.
4	FITTING-PERISTALTIC PUMP	054526
5	O-RING 1/2 OD x .070	024278

Pump A. - Mix Simplified Shake - X57028-XX

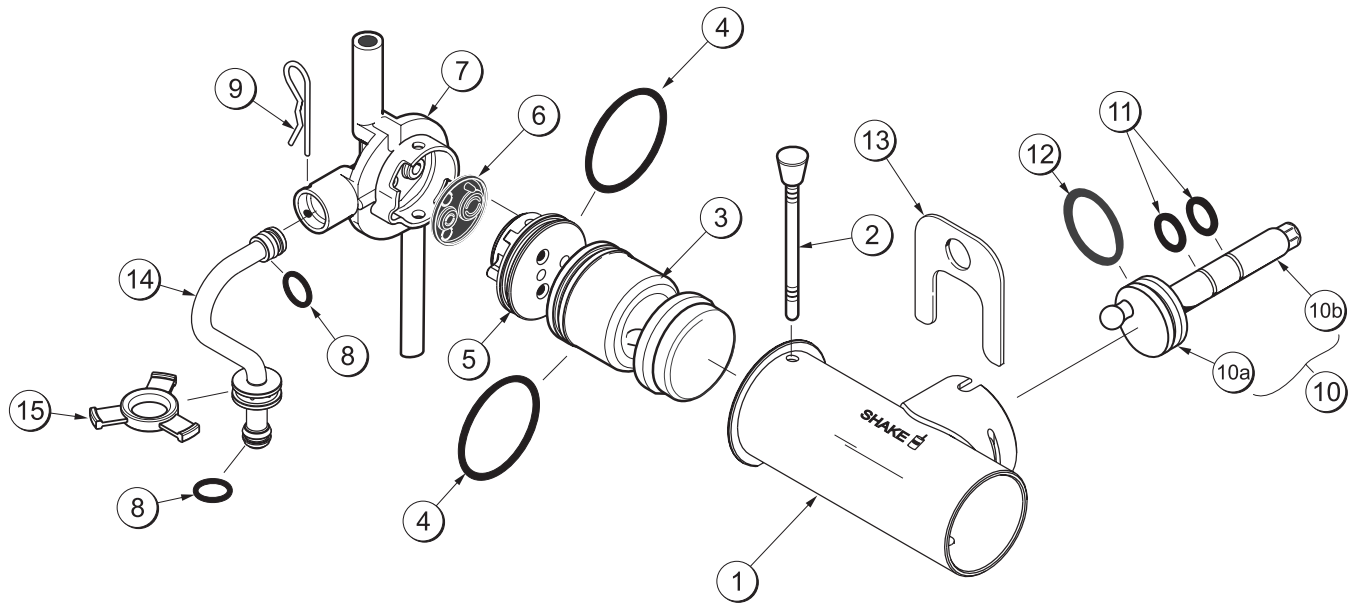

Figure 105

ITEM	DESCRIPTION	PART NO.
1 - 7	Pump A.-Mix Simplified Shake	X57028-XX
1	Cylinder-Pump-Hopper-Shake	057944
2	Pin A.-Retaining	X55450
3	Piston	053526
4	O-Ring 2-1/8" OD- Red	020051
5	Cap-Valve	056873-XX
6	Gasket-Simplified Pump	053527
7	Adaptor-Mix Inlet Shake-Blue	054944
8	O-Ring-11/16 OD - Red	016132

ITEM	DESCRIPTION	PART NO.
9	Pin-Cotter	044731
10	Shaft A.-Drive Mix Pump	X41947
10a	Crank-Drive	039235
10b	Shaft-Drive	041948
11	O-Ring-Drive Shaft	048632
12	O-Ring 1-3/4	008904
13	Clip-Mix Pump Retainer	044641
14	Tube A.-Feed-Hopper Shake	X55973
15	Ring-Check .120 OD	056524

Pump A. - Mix Simplified Soft Serve - X57029-XX

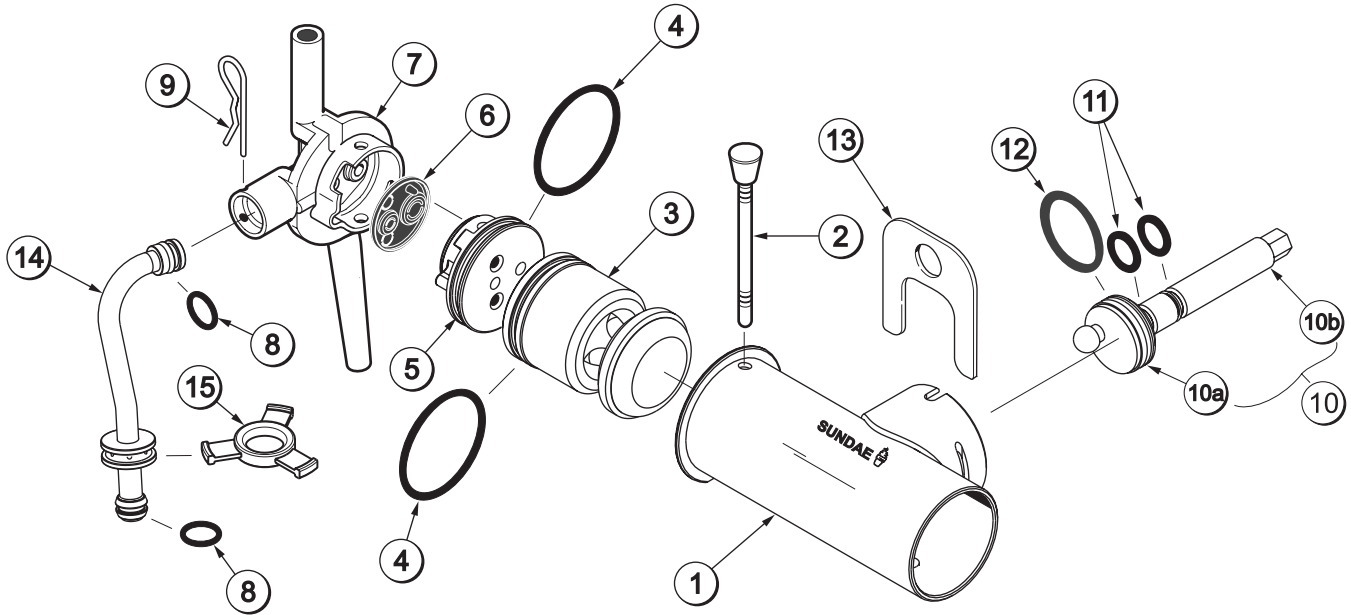

Figure 106

ITEM	DESCRIPTION	PART NO.
1	Cylinder-Pump-Hopper-Soft Srv	057943
2	Pin A.-Retaining	X55450
3	Piston	053526
4	O-Ring 2-1/8" OD - Red	020051
5	Cap-Valve	056874-XX
6	Gasket-Simplified Pump Valve	053527
7	Adaptor-Mix Inlet Soft Srv-Red	054825
8	O-Ring - 11/16 OD - Red	016132
9	Pin-Cotter	044731

ITEM	DESCRIPTION	PART NO.
10	Shaft A.-Drive-Mix Pump - Hopper	X41947
10a	Crank-Drive	039235
10b	Shaft-Drive	041948
11	O-Ring - Drive Shaft	048632
12	O-Ring 1-3/4	008904
13	Clip-Mix Pump Retainer	044641
14	Tube A.-Feed Hopper - Soft Srv	X55974
15	Ring-Check .120 OD	056524

Brush Identification

Note: For proper brush cleaning of the adapter, cap, feed tube, and orifice, refer to the following illustration which indicates proper brush usage.

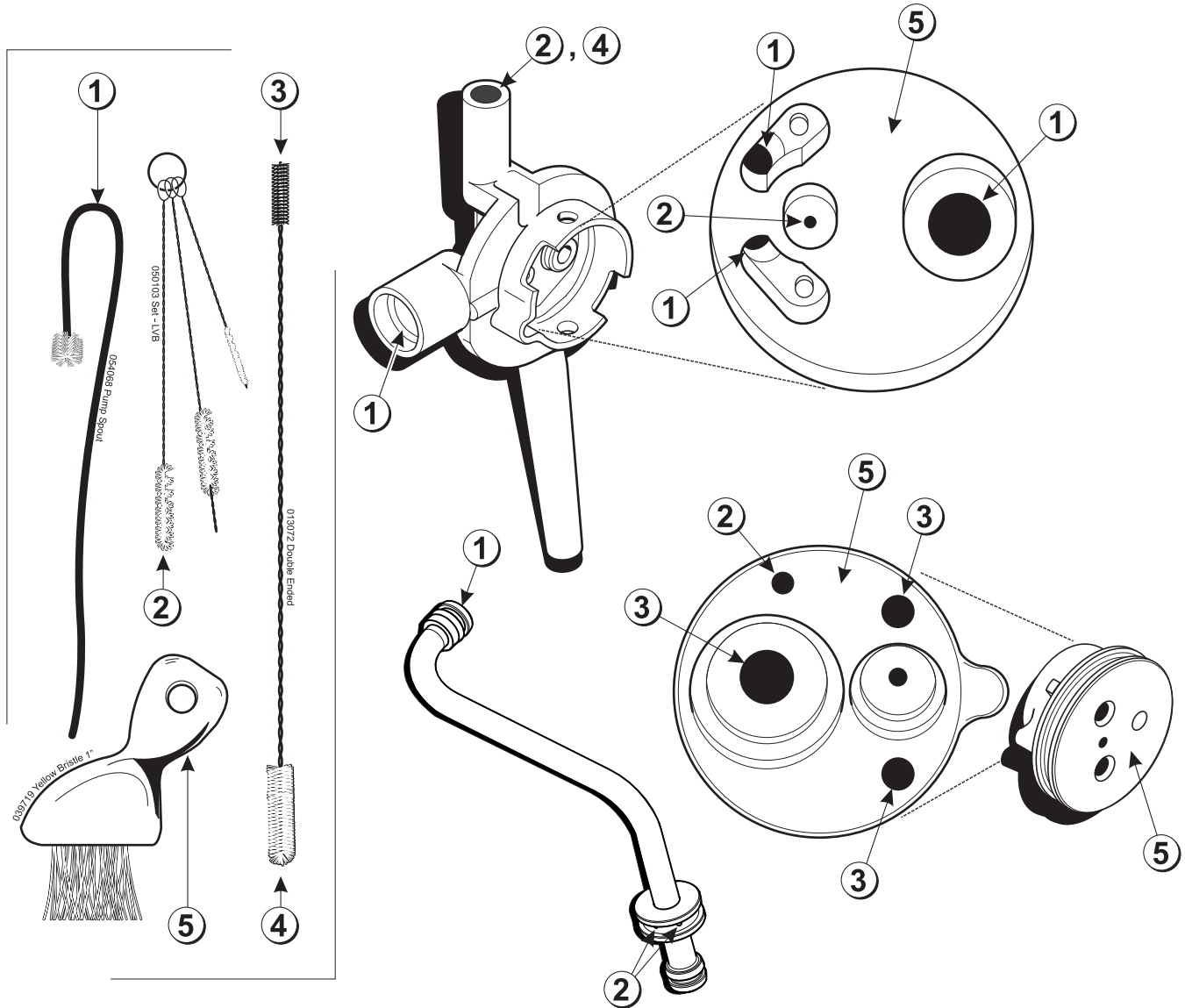

Figure 107

ITEM	DESCRIPTION
1	WHITE BRISTLE - 1/2" x 1/2"
2	WHITE BRISTLE - 3/16" x 1"
3	BLACK BRISTLE - 1/4" x 1-1/4"
4	WHITE BRISTLE - 1/2" x 1"
5	WHITE BRISTLE - 3" x 1/2"

Control Assembly - X55966-33

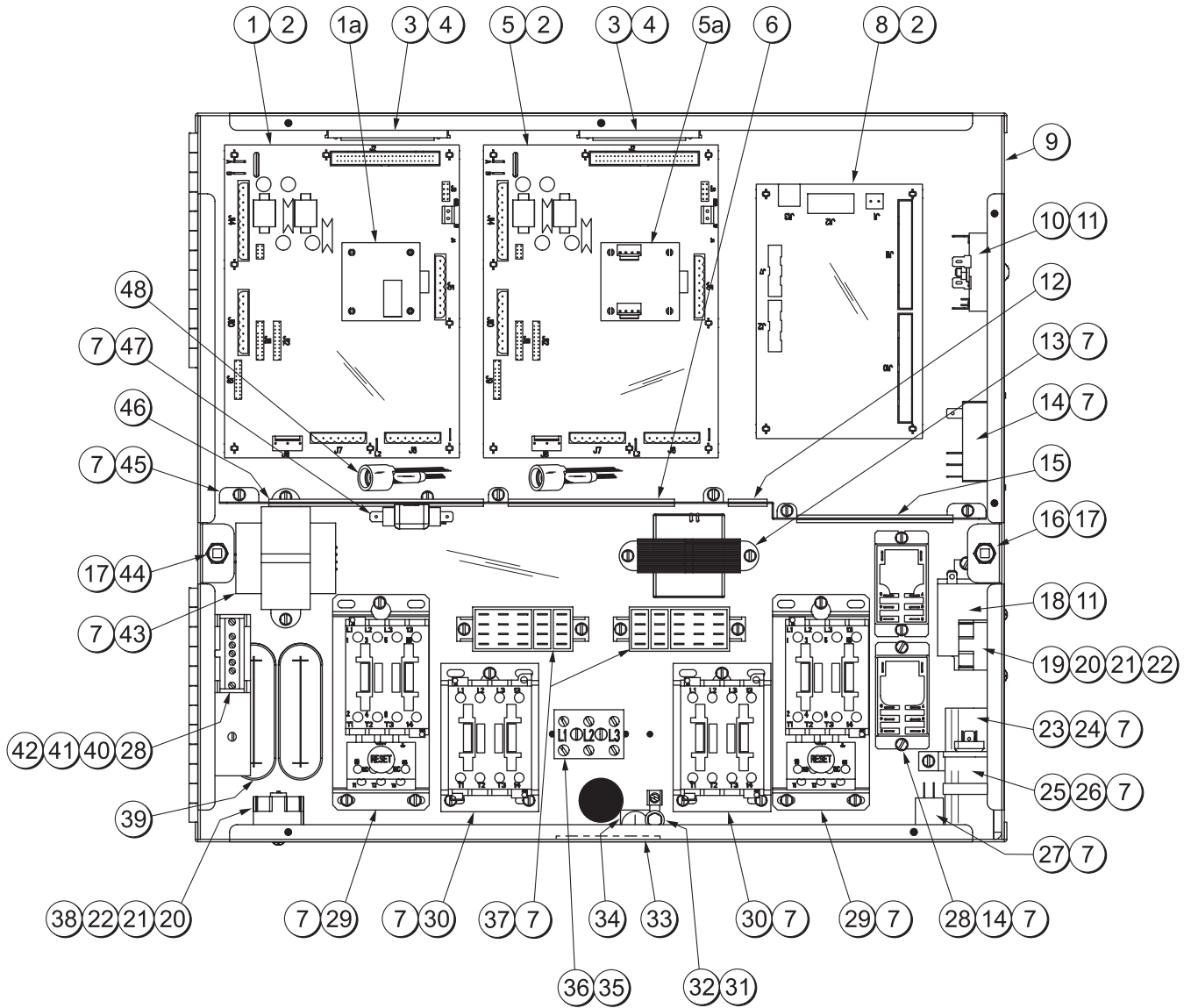

Figure 108

Control Assembly - X55966-33

ITEM	DESCRIPTION	PART NO.
1	PCB A.-INTERFACE-HT-SS-UK	X53453-SER
1a	PCB A.-PERSONALITY HT SS	X46904-SER
2	STANDOFF-NYLON-SNAP-1/2L	053413
3	COVER-CLAMP-RIBBON CABLE	045115
4	CLAMP-CABLE-RIBBON	045114
5	PCB A.-INTERFACE-HT-SH	X59076-SER
5a	PCB A.-PERSONALITY	X59072-SER
6	BEAD-RUBBER	010613-5
7	SCREW-8X1/4 SL HEX HD B	009894
8	PCB A.-CONTROL UVC3SM	X59210
9	BOX A.-CONTROL	X56423
10	CONTROL-SPEED-MOTOR	056530
11	SCREW-10-32X1-1/4 TRUSS	032936
12	BEAD-RUBBER	010613-1
13	TRANS.-CONT.-40VA 208/240V	053072
14	RELAY-DPDT-24VAC-30A@ 277	054703-03
15	BEAD-RUBBER	010613-4
16	OVERLOAD-TI#2BM-28B0R- KG1	042005-34
17	NUT-OVERLOAD RESET	045026
18	RELAY-SPST-30 A-240 V	032607-27
19	RELAY-MTR START TI#4CR-2-645	042007-34
20	WASHER-#6 SHAKEPROOF	024541
21	SCREW-6-32X3/8 BIN HD	002201
22	NUT-6-32 HEX	000927
23	CAPACITOR-START 47-56UF/220T	037251-34

ITEM	DESCRIPTION	PART NO.
24	STRAP-CAPACITOR 2-5/8"	056527
25	CAPACITOR-RUN 3UF/550V	035342-27
26	BRACKET-CAPACITOR 1-1/4 X 2	031205
27	CAPACITOR-RUN .8UF/400V	039482
28	SCREW-10-32X3/8 TAPTITE	039381
29	STARTER-3 PHASE-3 TO 5A	041950-33J
30	RELAY-3 POLE-20A-208/240	012725-33
31	BRACKET-RELAY A/C NO	057876
31	LUG-GROUNDING 260 W/GR.	020928
32	NUT-10-32 MF LOCK	020983
33	LABEL-COPPER COND ONLY	025948
34	LABEL-GROUNDING SYMBOL	017669
35	SCREW-8X1-1/4 RD HD TYP B	039420
36	BLOCK-TERMINAL 3P-L1,L2,L3	039423
37	BLOCK-TERMINAL 3P .25 SP	057201
38	RELAY-MTR START TI#4CR-1-625	039725-27
39	GROMMET-RIBBON CABLE	044999
40	BLOCK-TERMINAL 7P GREEN	024156
41	SCREW-8X1/2PAN HD TYP-A	017986
42	BRACKET-GROUND MOUNT	056801
43	TRANS.-CONT.-32VA 120/200/	054834
44	OVERLOAD-TI #2BM-20V9R-KK20	044464
45	SHIELD-NOISE ELECTRIC	056031
46	BEAD-RUBBER	010613-5.5
47	FILTER-CORCOM 6EH1	040140-001
48	HARNESS-WIRE	056425-

Dec Plate Assembly - X55963

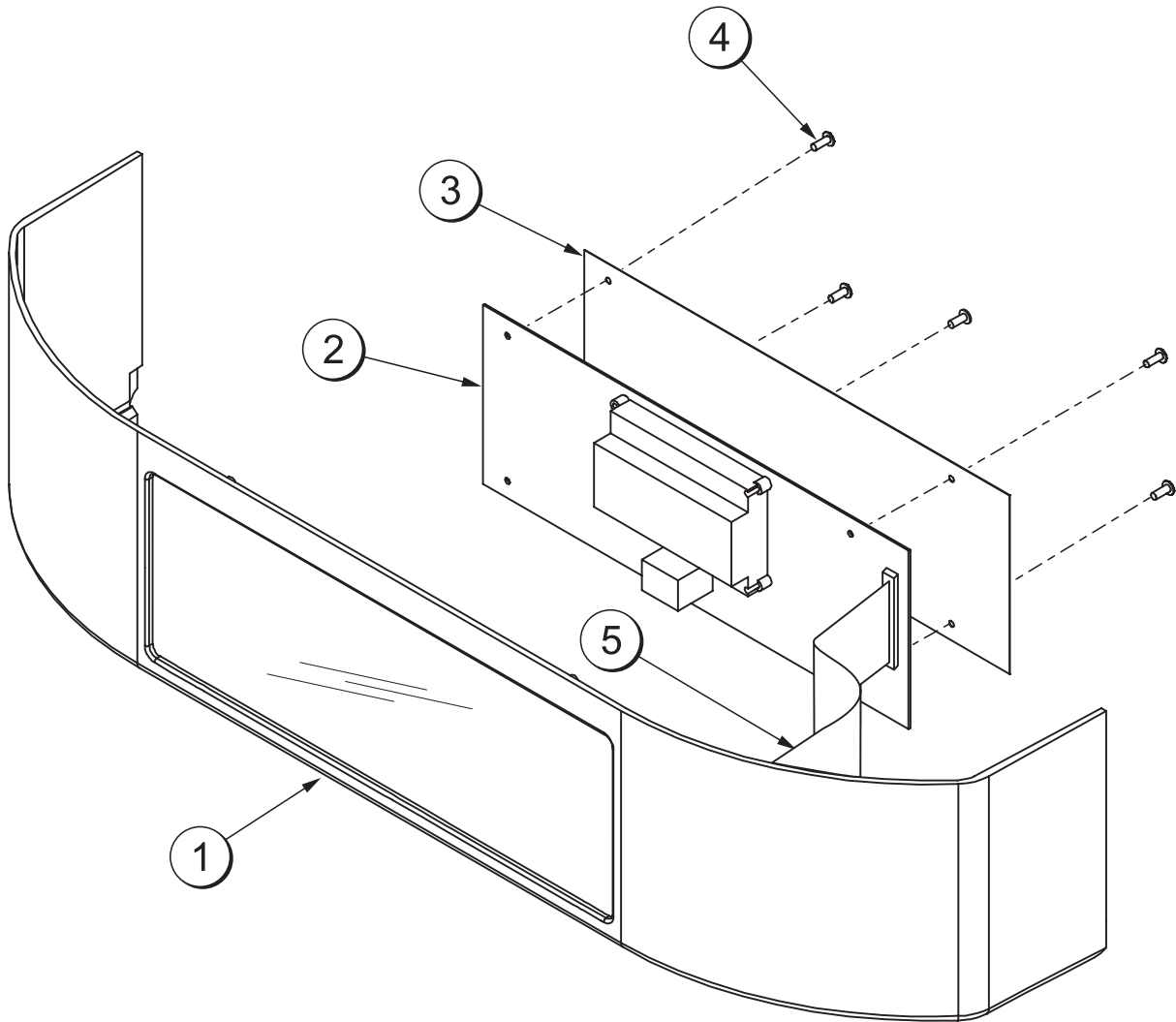

Figure 109

ITEM	DESCRIPTION	PART NO.
1	PLATE-DEC	056131
2	PCB A.-INTERFACE	X55960-SER
3	INSULATOR-PCB-INTERFACE	057168

ITEM	DESCRIPTION	PART NO.
4	SCREW-6-32 X 3/8 BIN. HD	002201
5	CABLE-RIBBON-14C-3"L	056864

Torque Coupling Ass

547

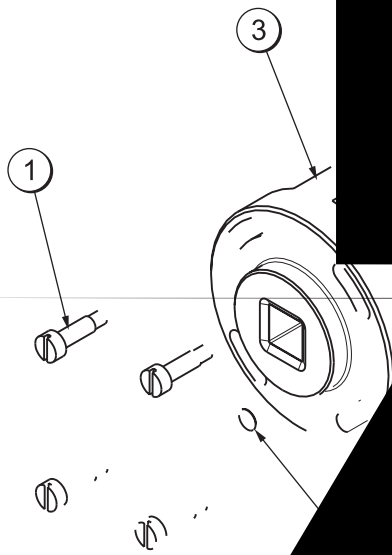

Glycol Heater Assembly - X55965-27

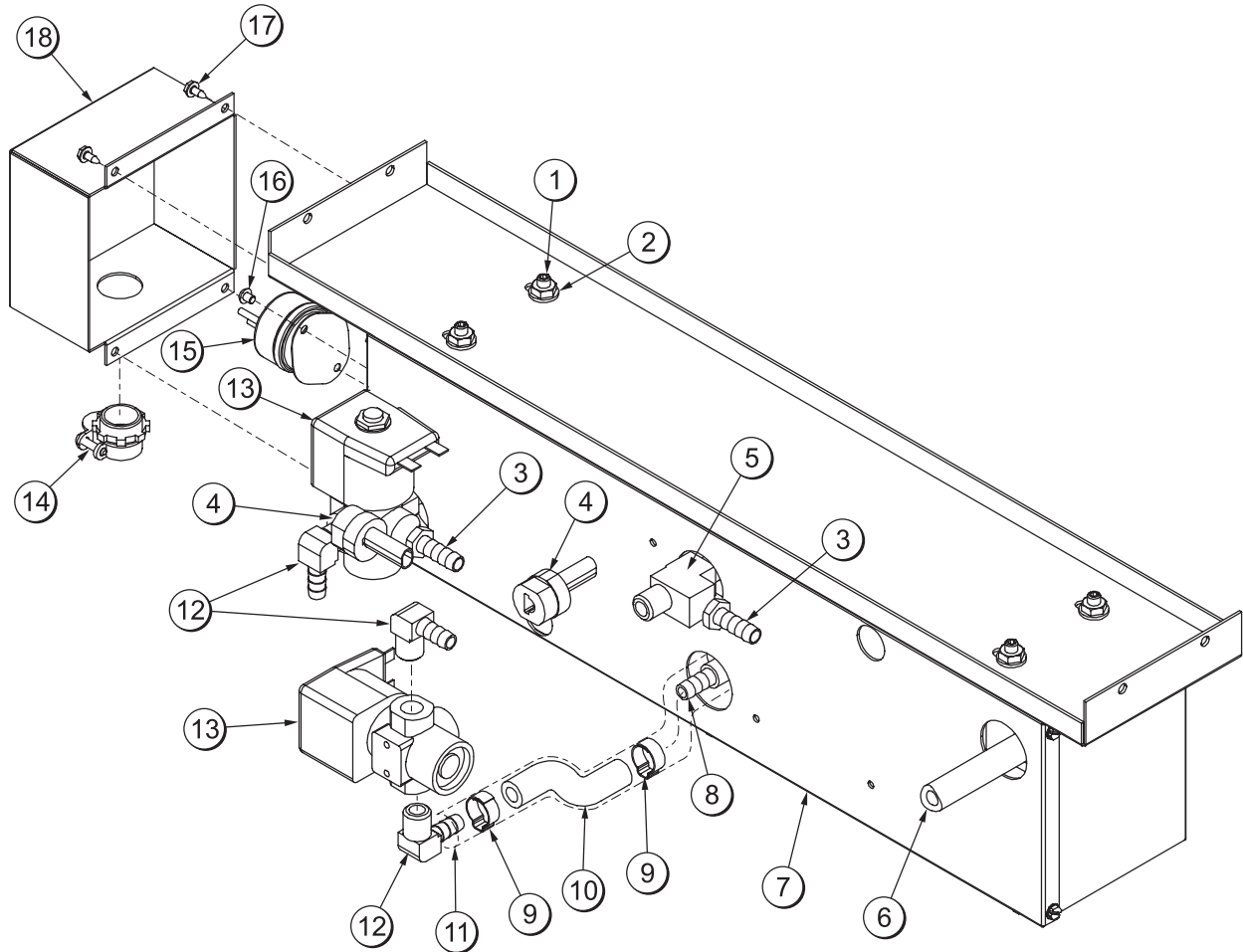

Figure 111

ITEM	DESCRIPTION	PART NO.
1	SCREW-1/4-20 X 1-1/4 SOCKT	015350
2	NUT-1/4-20 MF LOCK	017523
3	ADAPTOR-1/4 MP X 5/16 BARB	047326
4	RELIEF-STRAIN 7/8" HOLE	006968
5	TEE-1/4 FPT X 1/4 MPT	021277
6	HOSE-RUBBER 5/16 ID X 9/16	047340-16
7	HEATER A.-GLYCOL-4500	X47395-SER
8	ADAPTOR-5/16 FS X 5/16 BARB	047958
9	CLAMP-HOSE 35/64 STEPLES	047344

ITEM	DESCRIPTION	PART NO.
10	HOSE-RUBBER 5/16 X 9/16	047340-4
11	ARMAFLEX 1/2 ID X 3/8 WALL	020897-4
12	ELBOW-1/4 MP X 5/16 BARB	047327
13	VALVE-SOLENOID 3-W 1/4 FPT	037954-27
14	CONNECTOR-BX 3/8 STR2	014569
15	THERMOSTAT-HI LIMIT OPEN	035786
16	SCREW-8-32 X 3/16 SS RHM	017551
17	SCREW-6X3/8 SL HEX W HD	001825
18	COVER-TERMINAL HEATER	032864

Sensor Holder Assembly - X55980

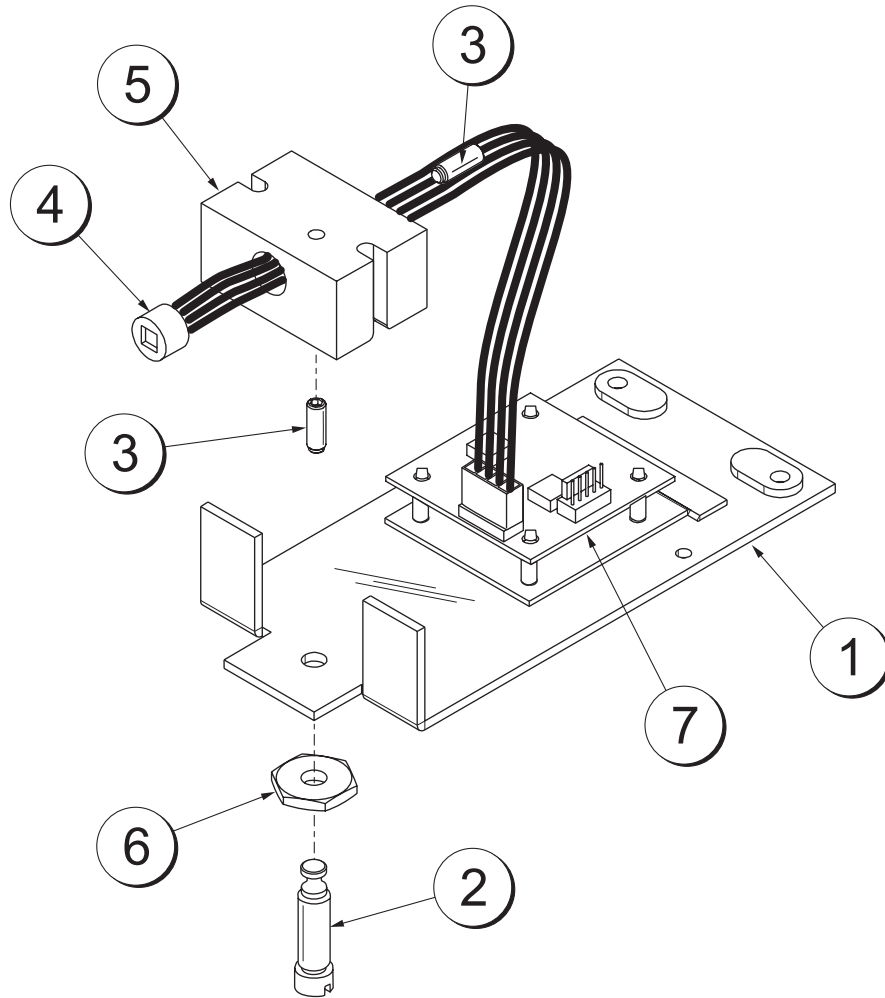

Figure 112

ITEM	DESCRIPTION	PART NO.
1	BRACKET A.-SENSOR	X56341
2	SCREW-ADJUSTMENT 5/16-18	051574
3	SCREW-10-32 X 9/16 DOG	038981
4	SLEEVE-SENSOR-PYROELEC	038982

ITEM	DESCRIPTION	PART NO.
5	HOLDER-MTG-SENSOR PROBE	056503
6	NUT-5/16-18 LOCK SS	043072
*7	PCB A.-PYRO	X59073-SER

*NOT INCLUDED W/X55980 SENSOR HOLDER ASSY.

Parts List

DESCRIPTION	PART NUMBER	QTY.	WARR. CLASS	REMARKS	PARTS UPDATE
ACCUMULATOR-COPPER 2"DIA 10"LG	047062	2	103		
AGITATOR A.-MIX HOPPER-20QT-HT	X44797	2	103		
+CAP-MAGNET *HT*	044796	2	103		
BEARING-DOOR-FRONT 1.390 OD	055605	1	000		
BEARING-FRONT-SHOE	050348	1	000	SOFT SERVE	
+SHOE-FRONT HELIX *REAR*	050346	1	000		
+SHOE-FRONT HELIX *FRONT*	050347	1	000		
BEARING-REAR SHELL-NICKEL	031324	2	000		
+GUIDE-DRIP SEAL	028992	2	000		
+NUT-BRASS BEARING	028991	2	000		
+O-RING-1/20D X .070W	024278	4	000		
+WASHER-BEARING LOCK	012864	2	000		
BEATER A.-3.4QT-1 PIN-SUPPORT	X46231	1	103	SOFT SERVE	
+BLADE-SCRAPER-PLASTIC 8-1/8L	046235	2	000		
+CLIP-SCRAPER BLADE 7.00 INCH	046236	2	103		
PIN-SCRAPER BLADE	009839	2	000		
BEATER A.-7QT-FLUTED BLADE	X50958	1	103	SHAKE	
+BLADE-SCRAPER-FCB 16L	041103	2	000		
BELT-AGITATOR *C602*	056017	1	000	9.5"	
BELT-AGITATOR 3/16	055933	1	000	5.7"	
BELT-AX31	041575	1	000	SHAKE SIDE	
BELT-AX33	024396	2	000	SOFT SERVE	
BLADE A.-SPINNER-ALUMINUM-HT	X59331	1	103		
BLOCK-HINGE	058614	4	103		
+PIN-HINGE	058615	4	103		
BLOCK-TERMINAL 3P .25 SPADE	057201	2	103		

+ Available Separately

DESCRIPTION	PART NUMBER	QTY.	WARR. CLASS	REMARKS	PARTS UPDATE
BLOCK-TERMINAL 3P-L1,L2,L3	039423	2	103		
BLOCK-TERMINAL 7P GREEN	024156	1	103		
BLOWER A.	X53725-27	1	103		
+CLIP-SCREEN-BLOWER	053730	4	103		
HOUSING-BLOWER-6 POLE	053728	1	103		
+MOTOR-FAN 208-230V 50/60 HZ	053481-27	1	103		
+SCREEN-BLOWER	053729	1	103		
+WHEEL-BLOWER	053726	1	103		
CABINET A.-ULT SYRUP *C602*	X55984	1	103		
CABLE A.-LOW VOLTAGE *C602*	056750	1	103		
CABLE-4 COND #22 SHIELDED	039309-50	1	103	POWER CABLE IF-UC (BULK P/N R600309)	
CABLE-RIBBON-10C-34"L-DIL/DIL	040040-023	1	103	J3 IF SS to SPEED CONTROL	
CABLE-RIBBON-14C-3"L-SIL/SIL	056864	1	103	DEC PLATE INTERFACE	
CABLE-RIBBON-20C-16"L-DIL/DIL	040040-049	1	103	J9 IF Shake to J7 UVC	
CABLE-RIBBON-20C-17"L-DIL/DILR	040040-013	2	103	J12 IF Ss TO J11 IF Shake, J12 IF Shake to J2 UVC	
CABLE-RIBBON-50C-20"L-DIL/DIL	040040-011	2	103	J2 IF Ss to J11 UVC, J2 IF Shake to J10 UVC	
CABLE-USB	056785	1	103	UVC TO DEC PLATE INTERFACE	
CASTER-4" SWV 3/4-10 STM	044106	4	103		
CONTROL-TOUCHPAD				SEE PLATE-DEC	
COMPRESSOR AHA2490ZXF-AH556RF	047519-33F	1	512	SOFT SERVE	
COMPRESSOR AHA7513ZXF-AH245RF	047520-33F	1	512	SHAKE	
CONDENSER-AC 12LX18HX3.12T-5RW	055813-1	1	103	LEFT-SHAKE SIDE	
CONDENSER-AC 12LX18HX3.12T-5RW	055813-2	1	103	RIGHT-SOFT SERV	
CONTROL-SPEED-MOTOR	056530	1	103		
CORD A.-POWER-250V-60A	X42136	1	103		

+ Available Separately

DESCRIPTION	PART NUMBER	QTY.	WARR. CLASS	REMARKS	PARTS UPDATE
COVER-HOPPER *BLACK*	053809-1	2	103		
+PIN-RETAINING-HOPPER COVER	043934	2	103		
COVER A.-SENSOR *C602*	X56882	1	103	PORTION CONTROL	
COUPLING A.-DRIVE-SPINNER	X20329	1	103		
COUPLING A.-TORQUE-SHAKE*4SPR*	X54722	1	103		
+COUPLING-TORQUE-DRIVE TTS	054723	1	103		
COUPLING-TORQUE-LOAD-SQ *TTS*	054724	1	103		
LABEL-IDENTIFICATION-GREEN	049285-GRN	1	000		
+PIN-COUPLING-TORQUE	039453	4	103		
+PIN-STOP-TORQUE COUPLING .792	054725	4	103		
+SCREW-5/16-18X3/8 ALLEN SET	025376	2	000		
+SCREW-SHOULDER 3/16DX1/2L-SS	039455	4	000		
+SPRING-3/8 ODX3/16 IDX1L-GREEN	039454	4	103		
COUPLING-DRIVE 3/4 HEX X 1-7/8	012721	1	103		
COUPLING-FLEXIBLE W/SCREWS	020108	1	103		
DECAL-INST-CLN-DAY-HT-C602	057064	1	000		
DECAL-INST-CLN-MAN-HT-C602	057065	1	000		
DECAL-SET OF 4 COLORED FLAVORS	022105	1	000		
DECAL-SYR COMPART-ROMANCE COMB	021571	1	000		
DECAL-TROUBLESHOOT	038374	1	000		
DEFLECTOR-BLOWER EXHAUST	047912	1	103		
DEFLECTOR-TORQUE COUPLING	054698	1	000		
DIAGRAM-WIRING *C602*	056007-33	1	000		
DISPENSER A.-CONE *C602*	X56121	1	103		
BOX A.-CUP-2 CONE DISPENSER	X56256	1	103		
BRACKET-DISPENSER *C602*	056260	1	103		
COVER-BACK DISPENSER BOX*C602*	056719	1	103		

+ Available Separately

DESCRIPTION	PART NUMBER	QTY.	WARR. CLASS	REMARKS	PARTS UPDATE
+COVER-CUP-2 CONE DISPENSER	044347	1	103		
DISPENSER A.-CONE-DRAWER-DBL	X56265	1	103		
+BAFFLE-RUBBER CONE-2 HOLE-SP	052193	2	000		
COVER A.-FRONT CONE DISPENSER	X52265	1	103		
+NUT-10-32 MF LOCK	020983	3	000		
PLUG-CONE DISPENSER SIMPLE	052263	2	000		
+RIVET-1/8D .188-.250 GR. STNL	024034	4	000		
+SPRING-CONSTANT FORCE .375W	028735	4	103		
TRAY A.-CONE *C602*	X56264	1	103		
+DISPENSER-CUP *NO RING*	019477-NR	2	103		
+DISPENSER-CUP-SUNDAE	039988	1	103		
+LATCH-SHELF	039783	1	103		
+NUT-10-32 MF LOCK	020983	4	000		
+POPPET-RUBBER-BLACK	022473	4	000		
+SCREW-10-32X3/8 TRUSS HD-SS	024298	4	000		
+SCREW-6X1/2 TYPE A-SS-TRUSS HD	022427	2	000		
+SCREW-SHOULDER 10-32X7/8	034965	1	000		
+SPACER-3/8OD X 5/32L NYLON	034964	1	000		
DOOR A.-CABINET *C602*	X58607	2	103		
DOOR A.-W/BAFFLE *C602*SERVICE	X57332-SER	1	103	SOFT SERVE	
+GASKET-DOOR HT 4"-DOUBLE	048926	1	000	SOFT SERVE	
HANDLE A.-DRAW-WELDED *C602*	X56421-1	1	103		
+PIN-HANDLE-SS *C602*	055819	1	103		
+SCREW-ADJUSTMENT-5/16-24 *602*	056332	1	103		
+O-RING-1/4 OD X .070W 50 DURO	015872	1	000		
+VALVE A.-DRAW *C602*	X55820	1	103		
+O-RING-7/8 OD X .103W	014402	3	000		

+ Available Separately

DESCRIPTION	PART NUMBER	QTY.	WARR. CLASS	REMARKS	PARTS UPDATE
DOOR-MACHINED-TTS SHAKE*BLACK*	X55825SER2	1	103	SHAKE	
+O-RING-6 IN ODX5 3/4 IDX 1/8	033493	1	000	DOOR GASKET	
+RETAINER-SYRUP VALVE *TTS*	054554	4	000		
+VALVE A.-DRAW *C602*	X57169	1	103		
+O-RING-DRAW VALVE-SHAKE	020571-1	2	000		
+SEAL-SPINNER SHAFT	036053	1	000		
DRYER-FILTER-HP62-3/8 X 1/4S	048901	2	000		
FASTENER-CLIP 1/4-20 U-TYPE	045865	16	000	PANELS	
FILTER-AIR-18.00LX13.50HX.70W	052779-3	2	000		
FILTER-CORCOM 6EH1	040140-001	1	103		
FITTING A.-SYRUP JUG TTS 36"	X53353-BLU	1	103		
+TUBE A.-SYRUP PICK UP	X53175	1	103		
+O-RING-1/2OD X .070W	024278	1	000		
+FERRULE-.625 ID NP BRASS	053036	2	000		
+CAP-ULTIMATE SYRUP	053040-BLU	1	000		
+HOSE-BEVERAGE 3/8"ID X 5/8"OD	053052-36	1	000		
+FITTING-PERISTALTIC PUMP	054526	1	103		
FITTING A.-SYRUP JUG TTS 36"	X53353-BRN	1	103		
+TUBE A.-SYRUP PICK UP	X53175	1	103		
+O-RING-1/2OD X .070W	024278	1	000		
+FERRULE-.625 ID NP BRASS	053036	2	000		
+CAP-ULTIMATE SYRUP	053040-BRN	1	000		
+HOSE-BEVERAGE 3/8"ID X 5/8"OD	053052-36	1	000		
+FITTING-PERISTALTIC PUMP	054526	1	103		
FITTING A.-SYRUP JUG TTS 36"	X53353-RED	1	103		
+TUBE A.-SYRUP PICK UP	X53175	1	103		
+O-RING-1/2OD X .070W	024278	1	000		

+ Available Separately

DESCRIPTION	PART NUMBER	QTY.	WARR. CLASS	REMARKS	PARTS UPDATE
+FERRULE-.625 ID NP BRASS	053036	2	000		
+CAP-ULTIMATE SYRUP	053040-RED	1	000		
+HOSE-BEVERAGE 3/8"ID X 5/8"OD	053052-36	1	000		
+FITTING-PERISTALTIC PUMP	054526	1	103		
FITTING A.-SYRUP JUG TTS 36"	X53353-WHT	1	103		
+TUBE A.-SYRUP PICK UP	X53175	1	103		
+O-RING-1/20D X .070W	024278	1	000		
+FERRULE-.625 ID NP BRASS	053036	2	000		
+CAP-ULTIMATE SYRUP	053040-WHT	1	000		
+HOSE-BEVERAGE 3/8"ID X 5/8"OD	053052-36	1	000		
+FITTING-PERISTALTIC PUMP	054526	1	103		
FITTING-PANEL MOUNT QD .250ID	056674	4	103		
FUSE-15 AMP-IN LINE-NON DELAY	045293	3	000		
+HOLDER-FUSE-IN LINE-TYPE HLR	045606	3	103		
GEAR A.*REDUCER 4.21:1	021286-SER	2	212		
GEAR A.*REDUCER-AGITATOR	047988	1	103		
GROMMET-VALVE-SPINNER *C602*	066704	1	000		
GUIDE A.-DRIP PAN CENTER*C602*	X55972	1	103	FRONT PANEL	
GUIDE A.-DRIP PAN-MIX PUMP	X48228	2	103	MIX PUMPS	
GUIDE A.-DRIP PAN-RIGHT *C602*	X55982	1	103	SOFT SERVE	
GUIDE A.-DRIP PAN-LEFT *C602*	X55983	1	103	SHAKE	
GUIDE-FILTER*444*632S*(8)754AC	053784	2	103		
HEATER A.-GLYCOL-4500 W-PRTL	X47395-SER	1	103		
+THERMOSTAT-HI LIMIT OPEN 200 F	035786	1	103		
HOLDER A.-SENSOR-ADJUSTABLE	X55980	1	103		
BRACKET A.-SENSOR *C602*	X56341	1	103		
HOLDER-MOUNTING-SENSOR PYROELE	056503	1	103		

+ Available Separately

DESCRIPTION	PART NUMBER	QTY.	WARR. CLASS	REMARKS	PARTS UPDATE
+NUT-5/16-18 LOCK SS	043072	1	000		
+SCREW-10-32X9/16 DOG PT SET	038981	2	000		
+SCREW-ADJUSTMENT-5/16-18	051574	1	103		
+SLEEVE-SENSOR-PYROELECTRIC	038982	1	000		
HOLDER-CUP-SHAKE-3.906 DIA	056008	1	103		
+CLIP-SPRING-CUP HOLDER	055192	2	103		
HOUSING A.-AGITATOR *LONG*	X51661	1	103		
+MAGNET A.-AGITATOR-INNER	X41733	1	103		
+SEAL-OIL	046124	2	000		
+SCREW-8-32X3/16 ALLEN SET	006812	2	000		
HOUSING A.-AGITATOR *SHORT*	X51664	1	103		
+MAGNET A.-AGITATOR-INNER	X41733	1	103		
+SEAL-OIL	046124	2	000		
+SCREW-8-32X3/16 ALLEN SET	006812	2	000		
JAR-SYRUP*PLASTIC*SHALLOW	036573	2	103		
JAR-SYRUP*STAINLESS*SHALLOW	036574	2	103		
KIT A.-PERISTALTIC PUMP TUBE	X54979	1	000		
LABEL-1/4 X 1-1/2 LONG-BROWN	022710	4	000		
LABEL-1/4 X 1-1/2 LONG-DK BLUE	022708	4	000		
LABEL-1/4 X 1-1/2 LONG-RED	022707	4	000		
LABEL-1/4 X 1-1/2 LONG-WHITE	022709	4	000		
LABEL-CAUTION-AGITATOR	045191	2	000		
LABEL-CAUTION-BTR STRT G3	039897	1	000		
LABEL-CAUTION-GRD-PERM-ENG/SP	032164	1	000		
LABEL-CAUTION-OVERHEAT-ROMANCE	030995	1	000		
LABEL-DOOR-MOVE PART	032749	1	000		
LABEL-OVERLOAD SETTING	045384	1	000		

+ Available Separately

DESCRIPTION	PART NUMBER	QTY.	WARR. CLASS	REMARKS	PARTS UPDATE
LABEL-RESET-MIX PMP	022723	2	000		
LABEL-RESET-MIX PMP	044452	2	000		
LABEL-SW-POWER-OFF/ON-SYMBOLS	052632	1	000		
LABEL-WARN-COVER	051433	5	000		
LABEL-WARN-LOCK-SHK-ENG/SPN	053760	1	000		
LID-SYRUP JAR	042706	2	103		
LINE A.-SYRUP DOOR *C602*	X56652	4	103	TO SHAKE DOOR/ WIDE SLOT SYRUP NOSE	
+FERRULE-.625 ID NP BRASS	053036	8	000		
+FITTING-BARB Q.D. .250 ID	056675	4	103		
+FITTING-SYRUP ELBOW	056651	4	103		
+FITTING-SYRUP NOSE .125 SLOT	056650	4	103		
+O-RING-11MM ID X 2MM W GREEN	053890	4	000		
+TUBE-NYLOBRADE 3/8IDX5/80D	500038-9	4	000		
+VALVE-CHECK-DUCKBILL	500598	4	000		
LINE A.-SYRUP BLUE *C602*	X56687	1	103	STAINLESS	
LINE A.-SYRUP BROWN *C602*	X56684	1	103	STAINLESS	
LINE A.-SYRUP RED *C602*	X56685	1	103	STAINLESS	
LINE A.-SYRUP WHITE *C602*	X56686	1	103	STAINLESS	
MAN-OPER C602	057888-M	1	000		176
MOTOR A.-SPINNER W/PLUG	X35584-27	1	103		
MOTOR-SPINNER-1/8 HP-3250 RPM	035341-27	1	103		
+CAPACITOR-RUN 3UF/550V	035342-27	1	103		
MOTOR-1.0 HP	013102-33	1	212	SHAKE	
MOTOR-1.5 HP	021522-33	1	212	SOFT SERVE	
MOTOR-AGITATOR	047987-27	1	103		
+CAPACITOR-RUN .8UF/400V	039482	1	103		

+ Available Separately

DESCRIPTION	PART NUMBER	QTY.	WARR. CLASS	REMARKS	PARTS UPDATE
MOTOR-GEAR ULTIMATE SYRUP	058725	4	103		
MOTOR-REDUCER 108RPM-SHK-HT	044723-27	1	212	SHAKE	
+OVERLOAD-TI#2BM-28B0R-KG16-68	042005-34	1	103		
+RELAY-MTR START TI#4CR-2-645	042007-34	1	103		
+NUT-OVERLOAD RESET	045026	1	000		
MOTOR-REDUCER 32 RPM-HPR PUMPM	036955-34	1	212	SOFT SERVE	
+CAPACITOR-START 47-56UF/220TO	037251-34	1	103		
+OVERLOAD-TI #2BM-20V9R-KK20-71	044464	1	103		
+RELAY-MTR START TI#4CR-1-625	039725-27	1	103		
+NUT-OVERLOAD RESET	045026	1	000		
NUT-STUD-BLACK 2.563 LONG	058764	6	103	LONG	
NUT-STUD-BLACK-1.00	055989	2	103	SHORT	
PAIL-MIX 10 QT.	013163	1	000		
PAN-DRIP 19-1/2 LONG	035034	1	103	FRONT PANEL	
PAN-DRIP-REAR *C602*	X56003	2	103	MIX PUMPS	
PAN-DRIP-SIDE *C602*	X56005	2	103	SIDE PANEL	
PANEL-REAR-LOWER *C602*	055959	1	103		
PANEL-REAR-UPPER *C602*	055958	1	103		
PANEL-SIDE LEFT *C602*	055957	1	103		
PANEL-SIDE RIGHT *C602*	055950	1	103		
PANEL-SYRUP CABINET-BACK*C602*	056387	1	103		
PANEL A.-FRONT *C602*	X55977	1	103	UPPER	
PANEL A.-FRONT *C602*	X55981	1	103	LOWER, INCLUDES SYRUP RAIL	
+CONTROL-LIMIT MANUAL RESET 450	077951	2	103		
+HEATER-STRIP-175W-240V	042782	2	103		
+LABEL-ADJ TEMP-SYMBOL	030994	2	000		
+LABEL-INST-SYRUP LABEL RESET	055810	2	000		

+ Available Separately

DESCRIPTION	PART NUMBER	QTY.	WARR. CLASS	REMARKS	PARTS UPDATE
+PLUG-DRAIN-WYOTT	023953-5	3	103		
+THERMOSTAT-ADJ-SNAP ACTING	049993	2	103		
PCB A.-PYRO *C602*	X59073-SER	1	212	SENSOR	
PCB A.-INTERFACE-HT-SH-C602	X59076-SER	1	212		
+PCB A.-PERSONALITY C602 SHAKE	X59072-SER	1	212		
+PCB A.-HEAT TREAT INTF BASE-UK	X53451-SER	1	212		
PCB A.-INTERFACE-HT-SS-UK	X53453-SER	1	212		
+PCB A.-PERSONALITY-HT-SS	X46904-SER	1	212		
+PCB A.-HEAT TREAT INTF BASE-UK	X53451-SER	1	212		
PCB A.-JVC3	X59210-SER	1	212	K3104504/JP	176
CONTROL-JVC3 SURFACE MOUNT	059189-SER	1	212		176
CHIP-SOFTWARE *C602* CS	X40829	1	103		176
PLATE-DEC *C602*	X55963-SER	1	103	INCLUDES TOUCHPAD CONTROL	
+PCB A.-INTERFACE *C602*	X55960-SER	1	212		
+SCREW-6-32X3/8 BIN.HD SLOT S	002201	4	000		
+PLATE-DEC *C602*	056131	1	103		
+CABLE-RIBBON-14C-3"L-SIL/SIL	056864	1	102		
+INSULATOR-PCB-INTERFACE *C60	057168	1	000		
+CHIP-SOFTWARE *C602* FP	X40821	1	103		
PROBE-THERMISTOR-HOPPER-2% TOL	039470-BLK	3	103		
PROBE-THERMISTOR-BARREL-2% TOL	038061-BLK	2	103		
PROBE A.-MIX LOW-HT	X42077	2	103		
+DISC-PROBE *SQ HOLE*	030965	2	103		
+SPACER-PROBE *SQ HOLE*	030966	2	103		
PROBE A.-MIX OUT-SQUARE HOLE	X41348	2	103		
+SPACER-PROBE-SQUARE HOLE-7/8	041346	2	103		
+SPACER-PROBE-ROUND HOLE-5/8DIA	041347	2	103		

+ Available Separately

DESCRIPTION	PART NUMBER	QTY.	WARR. CLASS	REMARKS	PARTS UPDATE
PULLEY-AGT DR-1.910PDX5/16 THD	036210	3	103	AGITATOR DRIVE	
PULLEY-AGT MTR-1.910PDX3/8BORE	042063	1	103	AGITATOR MOTOR	
+SCREW-8-32X1/4 ALLEN SET	043603	2	000		
PULLEY-2AK22 X .625-.6265	016403	1	103	SOFT SERVE MOTOR	
PULLEY-2AK74-5/8	027822	1	103	SOFT SERVE GEAR	
PULLEY-AK25-5/8	019153	1	103	SHAKE MOTOR	
PULLEY-AK64-5/8	007538	1	103	SHAKE GEAR	
PUMP A.-MIX SIMPLIFIED SHAKE	X57028-10	1	103	SUFFIX INDICATES VALVE CAP AIR ORIFICE SIZE	
+ADAPTOR-MIX INLET *SHAKE*BLUE*	054944	1	103		
+CAP-VALVE BODY SHAKE	056873-10	1	103	TRIPLE THICK SHAKE OVERRUN	
+CLIP-RETAINER-MIX PUMP	044641	1	103		
+CYLINDER A.-PUMP HOPPER SHAKE	057944	1	103		
+O-RING-2-1/8 OD X .139W #225	020051	2	000		
+PIN A.-RETAINING	X55450	1	103		
+PIN-COTTER-HAIRPIN-1/8DIA	044731	1	103		
+PISTON-PUMP-SIMPLIFIED	053526	1	103		
PUMP A.-MIX SIMPLIFIED S.S.	X57029-12	1	103	SUFFIX INDICATES VALVE CAP AIR ORIFICE SIZE	
+ADAPTOR-MIX INLET*SOFT/SER*RED	054825	1	103		
+CAP-VALVE BODY SS	056874-12	1	103	STANDARD ORIFICE SIZE USED FOR USA & CANADA	
+CLIP-RETAINER-MIX PUMP	044641	1	103		
+CYLINDER A.-PUMP HOPPER S.S.	057943	1	103		
+O-RING-2-1/8 OD X .139W #225	020051	2	000		
+PIN A.-RETAINING	X55450	1	103		
+PIN-COTTER-HAIRPIN-1/8DIA	044731	1	103		

+ Available Separately

DESCRIPTION	PART NUMBER	QTY.	WARR. CLASS	REMARKS	PARTS UPDATE
+PISTON-PUMP-SIMPLIFIED	053526	1	103		
PUMP A.-SYRUP-HEATED-BRN	X53800-BRN	1	103		
+PLUNGER A.-BROWN	X36576-BRN	1	103		
+PUMP A.-SYRUP HEATED *SHALLOW*	X53798-SER	1	103		
+LID	036579	1	103		
+NUT-LOCK-SYRUP PUMP	039680	1	000		
PUMP A.-SYRUP-HEATED-TAN	X53800-TAN	1	103		
+PLUNGER A.-TAN	X36576-TAN	1	103		
+PUMP A.-SYRUP HEATED *SHALLOW*	X53798-SER	1	103		
+LID	036579	1	103		
+NUT-LOCK-SYRUP PUMP	039680	1	000		
PUMP-GLYCOL-1/8NPT-1650 RPM	041785	1	103		
+BOOT-PUMP-GLYCOL	042131	1	000		
PUMP-PERISTALTIC	052916	4	103		
+CAP-MOTOR-PUMP-PERISTALTIC	055018	4	000		
RELAY-3 POLE-20A-208/240 50/60	012725-33	2	103		
RELAY-DPDT 20A-12VDC	077164-02	2	103		
RELAY-DPDT-24VAC-30A@277V	054703-03	3	103		
RELAY-SPST-30 A-240 V	032607-27	1	103		
SENSOR A.-EVC-SLUSH-6" *345-6*	X44951	1	103		
SENSOR A.-PYROELECTRIC-6"L	X59268	1	103		
SHAFT A.-DRIVE-MIX PUMP-HOPPER	X41947	2	103		
+CRANK-DRIVE-HOPPER MIX PUMP	039235	2	103		
+O-RING 1/2 ID X .139W	048632	4	000		
+SHAFT-DRIVE-MIX PUMP-HOPPER	041948	2	103		
+O-RING-1-3/4 OD X .139W	008904	2	000		
SHAFT-BEATER*7QT FLUTED BLADE	050985	1	103	SHAKE	

+ Available Separately

DESCRIPTION	PART NUMBER	QTY.	WARR. CLASS	REMARKS	PARTS UPDATE
+SEAL-DRIVE SHAFT	032560	1	000		
SHAFT-BEATER	032564	1	103	SOFT SERVE	
+SEAL-DRIVE SHAFT	032560	1	000		
SHIELD-SPLASH-WIRE-19-3/4 L	033813	1	103		
SHELF-SYRUP *C602*	056016	1	103		
SHELL A.-INSULATED *C602*	X55976	1	512		
+STUD-NOSE CONE *C602*	055987	8	103		
SHIELD-PYROELECTRIC SENSOR	039096	1	103		
RACK-SYRUP CABINET DOOR	059144	2	103		
SHROUD-FRONT *C602*	055944	1	103		
SHROUD-REAR *C602*	055943	1	103		
SHROUD-TOP *C602*	056504	1	103		
SLEEVE A.-MIX PUMP *HT*MCD	X44761	2	103		
+NUT-PUMP SLEEVE *8751*HT*	036933	2	000		
+MOUNT-MOTOR	036934	2	103		
STARTER-3 PHASE-3 TO 5 AMP	041950-33J	2	103		
SWITCH A.-DRAW *750-1-2*MASTER	X33322	1	103		
+ARM A.-DRAW *750/751/752 MC*	X33326	1	103		
+BRACKET A.-SWITCH *750/1/2*MC	X33323	1	103		
+E-RING 3/16 .335 O.D.	049178	1	000		
+PIN-PIVOT	015478	1	103		
+SCREW-4-40X1/2 RHM STEEL-ZP	030427	2	000		
+SPRING-RETURN R.	023488	1	103		
+SWITCH-LEVER-SPDT-10A-125-250V	028889	1	103		
SPINNER *8663*	034054	1	103		
SWITCH-PRESSURE 440 PSI-SOLDER	048230	2	103		
SWITCH-REED*DOOR INTERLOCK*68"	056771	1	103	SHAKE	

+ Available Separately

DESCRIPTION	PART NUMBER	QTY.	WARR. CLASS	REMARKS	PARTS UPDATE
SWITCH-REED *DOOR INTERLOCK*97	059071	1	103	SOFT SERVE	
SWITCH-TOGGLE-DPDT*VDE APPROVD	054809	1	103	DEC PLATE	
+GUARD-POWER SWITCH	034830	1	103	FRONT PANEL	
TANK-GLYCOL 1.5QT-PLASTIC	047314	1	103		
TRAY A.-DRIP-SYRUP CABINET	X56006	1	103		
TRAY-DRIP-19-5/8 L X 4-7/8	033812	1	103		
TRAY-PARTS-SS SIDE C602	059087	1	000		
TRAY-PARTS-SHAKE SIDE C602	059088	1	000		
TRIM-CORNER-REAR-L *C602*	056693	1	103		
TRIM-CORNER-REAR-R *C602*	056692	1	103		
TRANS.-CONT.-32VA 120/200/240V	054834	1	103		
TRANS.-CONT.-40VA 208/240V	053072	1	103		
TUBE A.-FEED TUBE-SHK *C602*	X55973	1	103	SHAKE	
+RING-CHECK-FEED-TUBE	056524	1	000		
+O-RING-11/16ODX.103W-RED	016132	2	000		
TUBE A.-FEED TUBE-SS *C602*	X55974	1	103	SOFT SERVE	
+RING-CHECK-FEED-TUBE	056524	1	000		
+O-RING-11/16ODX.103W-RED	016132	2	000		
TUBE-VINYL 1/4ID X 1/16WALL	R30312	7.5 FT	000	SYRUP LINES	
VALVE A.-DISPENSING *C602*	X57906	1	103	SHAKE DISPENSING VALVE	
+BRACKET-COUPPLING-ACTUATOR	056620	1	103		
+BUMPER-RECESSED	057910	1	103		
+GUIDE-ACTUATOR	057909	1	103		
+MOUNT A.-SPINNER	X57905	1	103		
+NUT-1/4-20 MF LOCK	017523	2	000		
+SCREW-1/4-20X1-1/4MF HEX CAP	024351	1	000		
+SCREW-1/4-20X3/4 SHC*LOW HD	057911	1	000		

+ Available Separately

DESCRIPTION	PART NUMBER	QTY.	WARR. CLASS	REMARKS	PARTS UPDATE
+SCREW-1/4-20X5/8 MF HEX CAP	017522	2	000		
+SOLENOID-DRAW VALVE-SH *C602	059462	1	103	K3127011/Up	
VALVE-ACCESS-1/4MFL X 3/8ODSDR	053565	4	103		
VALVE-EXP-AUTO-1/4S X1/4 FPT	046365	2	103		
+BOOT-VALVE-EXPANSION	050900	2	000		
VALVE-SOLENOID 3-W 1/4FPT 240V	037954-27	2	103	GLYCOL HEATER	
ACCESSORIES					
BRUSH A.-PACKAGE-HT	X44127	1	000		
+BRUSH-REAR BRG 1"D X 2"LG X	013071	1	000		
+BRUSH-DBL END-PUMP & FEED TU	013072	1	000		
+BRUSH-DRAW VALVE 1"OD X 2"X1	013073	1	000		
+BRUSH-DRAW VALVE 1-1/2"OD X	014753	1	000		
+BRUSH-MIX PUMP BODY-3" X 7"	023316	1	000		
+BRUSH-1/2" DIA	033059	1	000		
+BAG-POLY 12 X 24 2 MIL	039093	1	000		
+BRUSH-END-DOOR-SPOUT-SS-HT	039719	1	000		
+CHART-BRUSH KIT-HT	044127	1	000		
+BRUSH-SET LVB	050103	1	000		
+BRUSH-PUMP SPOUT *MC13*	054068	1	000		
KIT A.-ACCESSORY *C602*	X56001	1	000		
+CAP A.-VALVE-DRAW-INSULATED	X54704	1	103		
+DECAL-MAG-CLOSING CHECK	044309	1	000		
+KIT A.-PERISTALTIC PUMP TUBE	X54978	1	000		
+O-RING-1/2OD X .070W	024278	2	000		
+TOOL-O-RING REMOVAL-FREEZER	048260-WHT	1	000		
+TUBE-PUMP-PERISTALTIC	054514	1	000		

+ Available Separately

DESCRIPTION	PART NUMBER	QTY.	WARR. CLASS	REMARKS	PARTS UPDATE
+O-RING-1-11/16 OD X.139W	041923	1	000		
+TOOL-O-RING REMOVAL-FREEZER	048260-WHT	1	000		
+TOOL-SEAL INSTALL-REMOVE	035460	1	000		
+TOOL-SHAFT-DRIVE-PUMP-HOPPER	057167	1	000		
KIT A.-TOOL BOX 1SPT TTS	X49463-75	1	000		
+KIT A.-TUNE UP-C602	X49463-59	1	000		
+KIT A.-DRAW VALVE *SHAKE C602*	X56200-12	1	000		
+O-RING-DRAW VALVE-SHAKE	020571-1	2	000		
+CAP-RESTRICTOR	033107	1	000		
+SEAL-SPINNER SHAFT	036053	1	000		
+KIT A.-DOOR/BARREL *SHAKE C602	X56200-13	1	000		
+SEAL-DRIVE SHAFT	032560	1	000		
+O-RING-6 IN ODX5 3/4 IDX 1/8	033493	1	000		
+O-RING-1-11/16 OD X.139W	041923	1	000		
+O-RING-11MM ID X 2MM W GREEN	053890	4	000		
+BEARING-DOOR-FRONT 1.390 OD	055605	1	000		
+KIT A.-DOOR/BARREL SS C602	X56200-14	1	000		
+O-RING-7/8 OD X .103W	014402	3	000		
+SEAL-DRIVE SHAFT	032560	1	000		
+SHOE-FRONT HELIX *REAR*	050346	1	000		
+SHOE-FRONT HELIX *FRONT*	050347	1	000		
+BEARING-FRONT-SHOE	050348	1	000		
+GASKET-DOOR HT 4"-DOUBLE	048926	1	000		
+KIT A.-PUMP-SIMPLIFIED SS/SHK	X56200-10	2	000		
+GASKET-SIMPLIFIED PUMP VALVE	053527	2	000		
+O-RING 1/2 ID X .139W	048632	4	000		
+O-RING-11/16ODX.103W-RED	016132	4	000		

+ Available Separately

DESCRIPTION	PART NUMBER	QTY.	WARR. CLASS	REMARKS	PARTS UPDATE
+O-RING-1-3/4 OD X .139W	008904	2	000		
+O-RING-2-1/8 OD X .139W #225	020051	4	000		
+RING-CHECK-FEED-TUBE	056524	2	000		
+KIT A.-SYRUP VALVE TTS	X56200-15	1	000		
+O-RING-.441 OD X .070W	500205	4	000		
+O-RING-11MM ID X 2MM W GREEN	053890	4	000		
+VALVE-CHECK-DUCKBILL	500598	4	000		
+TOOL-O-RING REMOVAL-FREEZER	048260-WHT	1	000		
KIT A.-TOPPING PUMP SPARES	X53795	1	000		
+BRUSH-1/2" DIA	033059	1	000		
+BRUSH-PUMP SPOUT *MC13*	054068	1	000		
+O-RING-1 OD X .103W	048148	2	000		
+O-RING-1-5/16 OD X.103W	048149	2	000		
+O-RING-9/16 OD X .103W	016369	2	000		
+SEAL A.	X33057	2	000		
+WASHER-NYLON	032760	2	000		
KIT A.-SYRUP PLUG KIT TTS	X58474	1	000		
+TOOL-SEAL INSTALL-REMOVE	035460	1	000		
+PLUG-SYRUP PORT TTS	053867	4	000		
+O-RING-11MM ID X 2MM W GREEN	053890	4	000		
CUP-DIVIDED SYRUP	017203	1	000		
LADLE-1 OZ-120D BEND IN HAND	033637-1	2	000		
BOTTLE-WASH-PLASTIC	044818	1	000		
LUBRICANT-TAYLOR HI PERF-4 O	048232	1	000		
MSDS-LUBRICANT HI PERFORMANC	048232MSDS	1	000		
TOOL-SHAFT-DRIVE-PUMP-HOPPER	057167	1	000		
BOX-TOOL 15 INCH PLASTIC	058669	1	000		

+ Available Separately

DESCRIPTION	PART NUMBER	QTY.	WARR. CLASS	REMARKS	PARTS UPDATE
BOTTLE-WASH-PLASTIC	044818	1	000		
50HZ					
BELT-AX31	041575	1	000	SHAKE	
BELT-AX34	025729	2	000	SOFT SERVE	
BLOCK-TERMINAL 4P-L1,L2,L	039424	2	103		
BLOCK-TERMINAL 7P GREEN	024156	2	103		
CAP-VALVE BODY SHAKE	056873-12	1	103	INCLUDED WITH ACCESSORIES	
CAP-VALVE BODY SHAKE	056873-16	1	103	INCLUDED WITH ACCESSORIES	
CAP-VALVE BODY SS	056874-12	1	103	INCLUDED WITH ACCESSORIES	
CAP-VALVE BODY SS	056874-16	1	103	INCLUDED WITH ACCESSORIES	
COMPRESSOR AHA2490ZXG-AH5	047519-62F	1	512	SOFT SERVE	
COMPRESSOR AHA7513ZXG-AH2	047520-62F	1	512	SHAKE	
DECAL-SET OF 4 SYRUP FLAV	021523	1	000		
DIAGRAM-WIRING *C602*	056007-58	1	000		
HOLDER A.-LID *5472*	X42811	3	103		
HOLDER-CUP-SHAKE-EUROPE	038985-1	1	103		
LINE A.-SYRUP *C602*	X58450	4	103	SYRUP IN BAG	
+TUBE-VINYL 3/16ID X 1/16 WAL	020940-8	1	000		
+O-RING-1/20D X .070W	024278	1	000		
+FERRULE-.625 ID NP BRASS	053036	2	000		
+HOSE-BEVERAGE 3/8"ID X 5/8"O	053052-36	1	000		
+FITTING-PERISTALTIC PUMP	054526	1	103		
+COUPLING-3/8 BARBED FEMALE	058451	1	103		
+COUPLING-1/4 BARBED MALE	058452	1	103		
LINE A.-SYRUP DOOR *C602*	X59304	4	103	TO SHAKE DOOR/ NARROW SLOT SYRUP NOSE	
+FERRULE-.625 ID NP BRASS	053036	2	000		

+ Available Separately

DESCRIPTION	PART NUMBER	QTY.	WARR. CLASS	REMARKS	PARTS UPDATE
+O-RING-11MM ID X 2MM W GREEN	053890	1	000		
+FITTING-SYRUP NOSE .075 SLOT	056649	1	103		
+FITTING-SYRUP ELBOW	056651	1	103		
+FITTING-BARB Q.D. .250 ID	056675	1	103		
+TUBE-NYLOBRADE 3/8IDX5/8OD	500038-9	1	000		
+VALVE-CHECK-DUCKBILL	500598	1	000		
MOTOR-1.0 HP	013102-35	1	212	SHAKE	
MOTOR-1.5 HP	021522-35	1	212	SOFT SERVE	
MOTOR-REDUCER 108RPM-SHK-	044723-34S	1	212	SHAKE	
PULLEY-2AK27 X .625-.6265	011545	1	103	SOFT SERVE MOTOR	
PULLEY-AGT DR-1.690PDX51	045717	1	103		
PULLEY-AGT DR-1.910PDX51	036210	2	103		
PULLEY-AGT MTR-2.110PDX3	045718	1	103		
PULLEY-AK30 X 58	033559	1	103	SHAKE MOTOR	
PUMP A.-MIX SIMPLIFIED SHAKE	X57028-14	1	103	SUFFIX INDICATES VALVE CAP AIR ORIFICE SIZE	
+ADAPTOR-MIX INLET *SHAKE*BLUE*	054944	1	103		
+CAP-VALVE BODY SHAKE	056873-14	1	103		
+CLIP-RETAINER-MIX PUMP	044641	1	103		
+CYLINDER A.-PUMP HOPPER SHAKE	057944	1	103		
+O-RING-2-1/8 OD X .139W-#225	020051	2	000		
+PIN A.-RETAINING	X55450	1	103		
+PIN-COTTER-HAIRPIN-1/8DIA	044731	1	103		
+PISTON-PUMP-SIMPLIFIED	053526	1	103		
PUMP A.-MIX SIMPLIFIED S.S.	X57029-14	1	103	SUFFIX INDICATES VALVE CAP AIR ORIFICE SIZE	
+ADAPTOR-MIX INLET*SOFT/SER*RED	054825	1	103		

+ Available Separately

DESCRIPTION	PART NUMBER	QTY.	WARR. CLASS	REMARKS	PARTS UPDATE
+CAP-VALVE BODY SS	056874-14	1	103		
+CLIP-RETAINER-MIX PUMP	044641	1	103		
+CYLINDER A.-PUMP HOPPER S.S.	057943	1	103		
+O-RING-2-1/8 OD X .139W #225	020051	2	000		
+PIN A.-RETAINING	X55450	1	103		
+PIN-COTTER-HAIRPIN-1/8DIA	044731	1	103		
+PISTON-PUMP-SIMPLIFIED	053526	1	103		
STARTER-3 PH 1.4 TO 2.3A	041950-33G	1	103		
STARTER-3 PHASE-2.0 TO 3.	041950-33H	1	103		
TANK-SYRUP 4QT. PSD	056673	4	103	OPTIONAL TANKS	
+COVER-SYRUP TANK	055432	4	103		
+O-RING	To Advise	4	000		
TRAY A.-SYRUP *C602*	X59143	1	103	SYRUP BAG TRAY	

+ Available Separately

