

MICROAIRE SERIES 5 RS

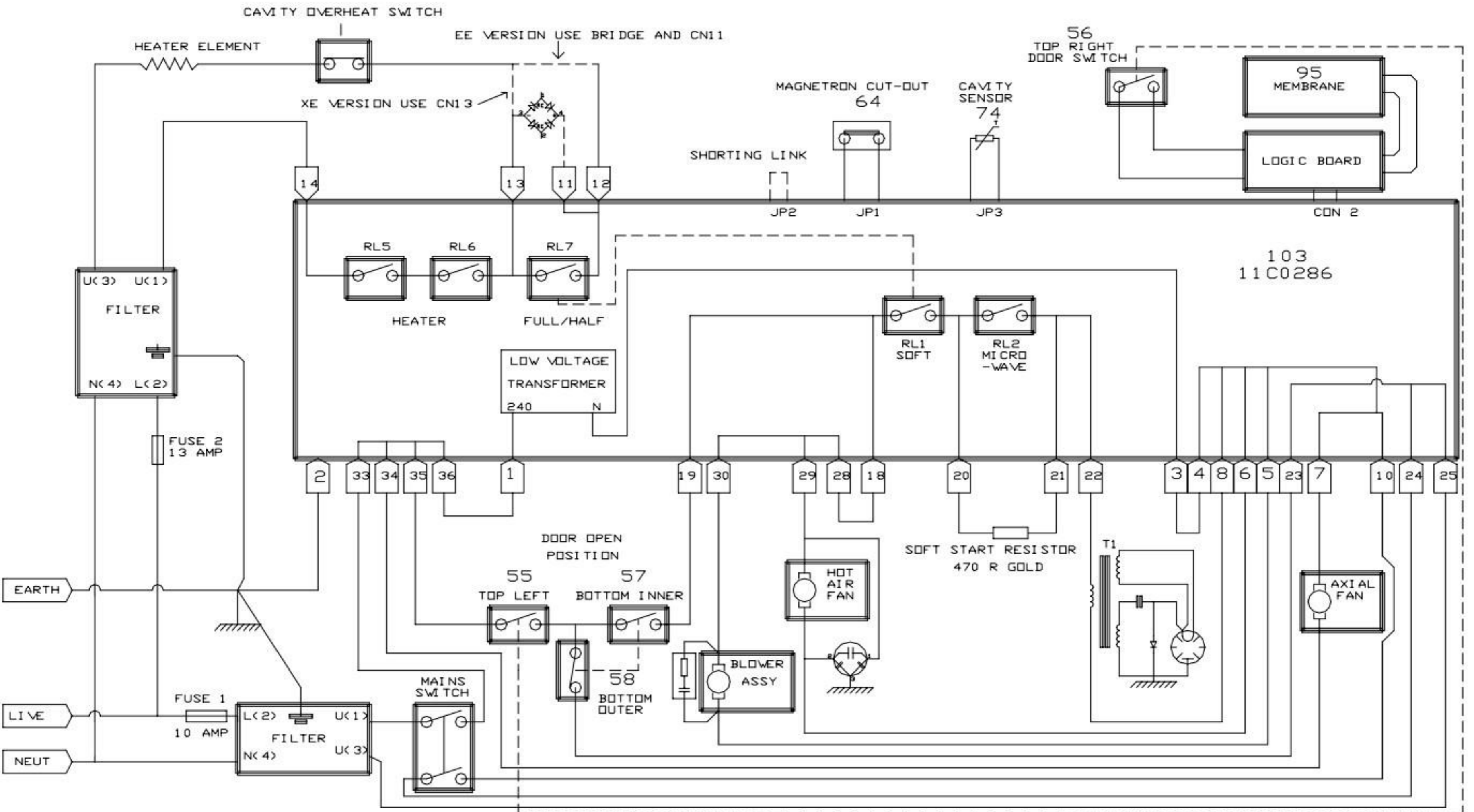

WIRING DIAGRAM - MICROWAIRE SERIES 5 EE (13A) AND XE (30A)

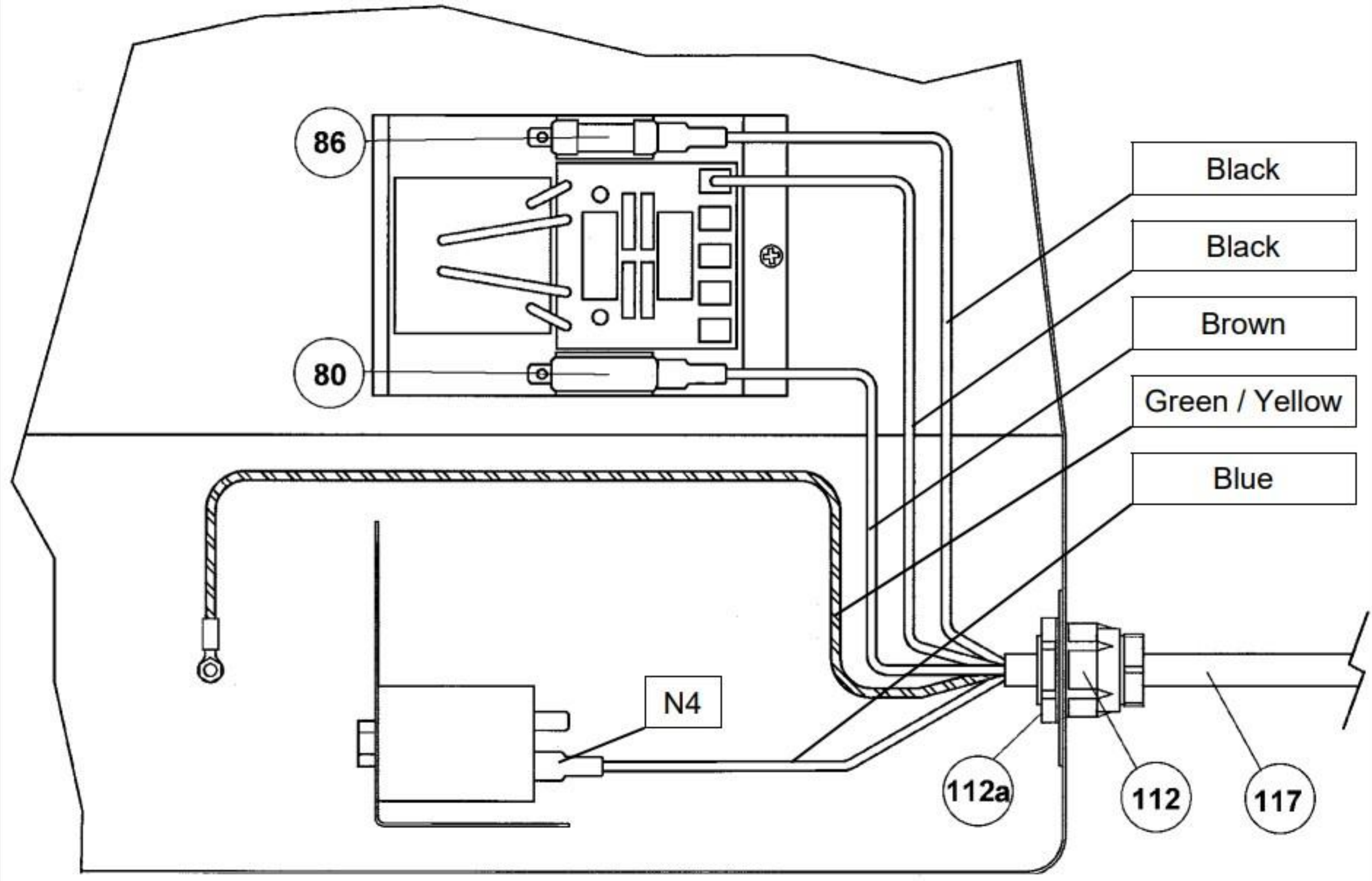

86

80

Black

Black

Brown

Green / Yellow

Blue

N4

112a

112

117

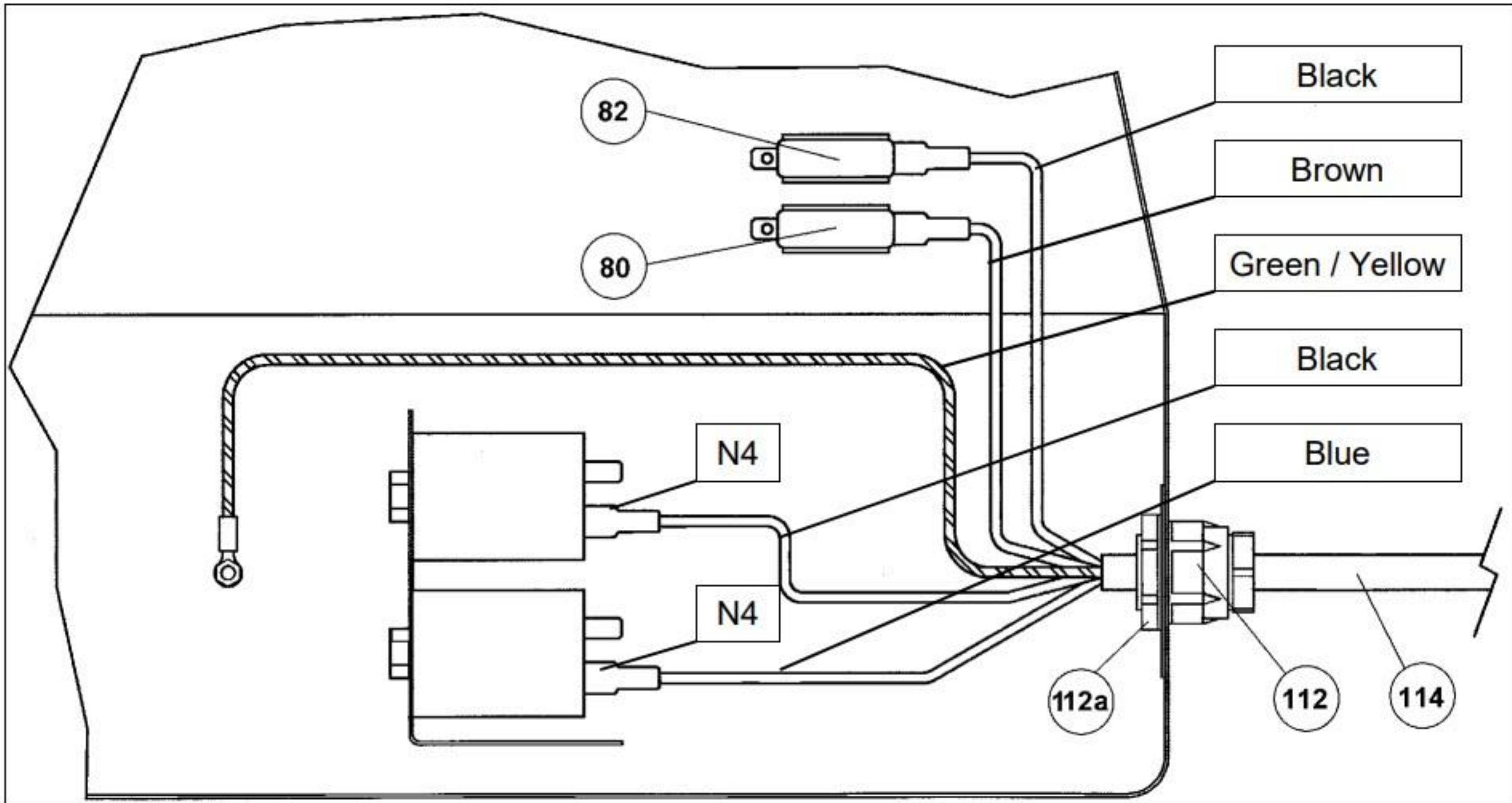

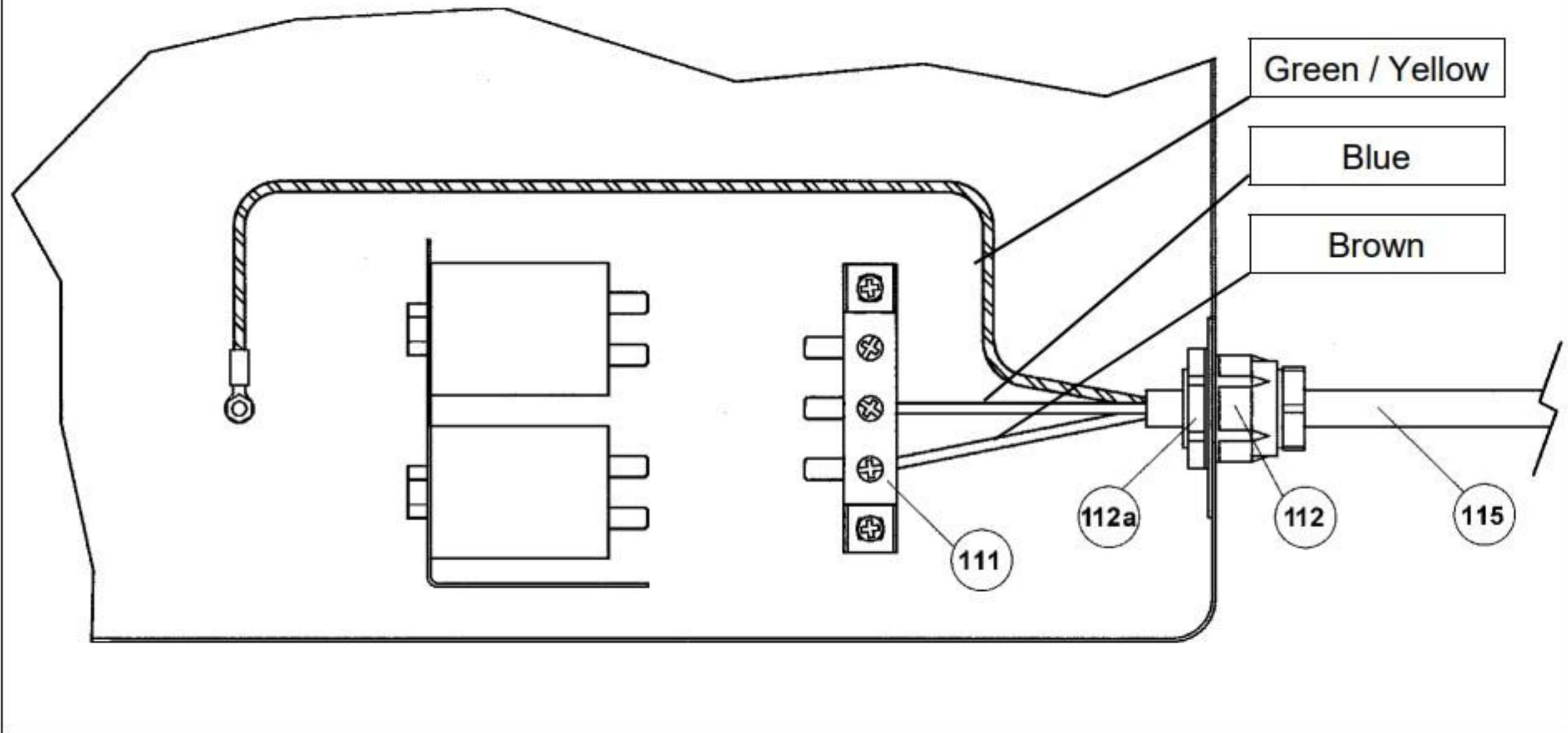

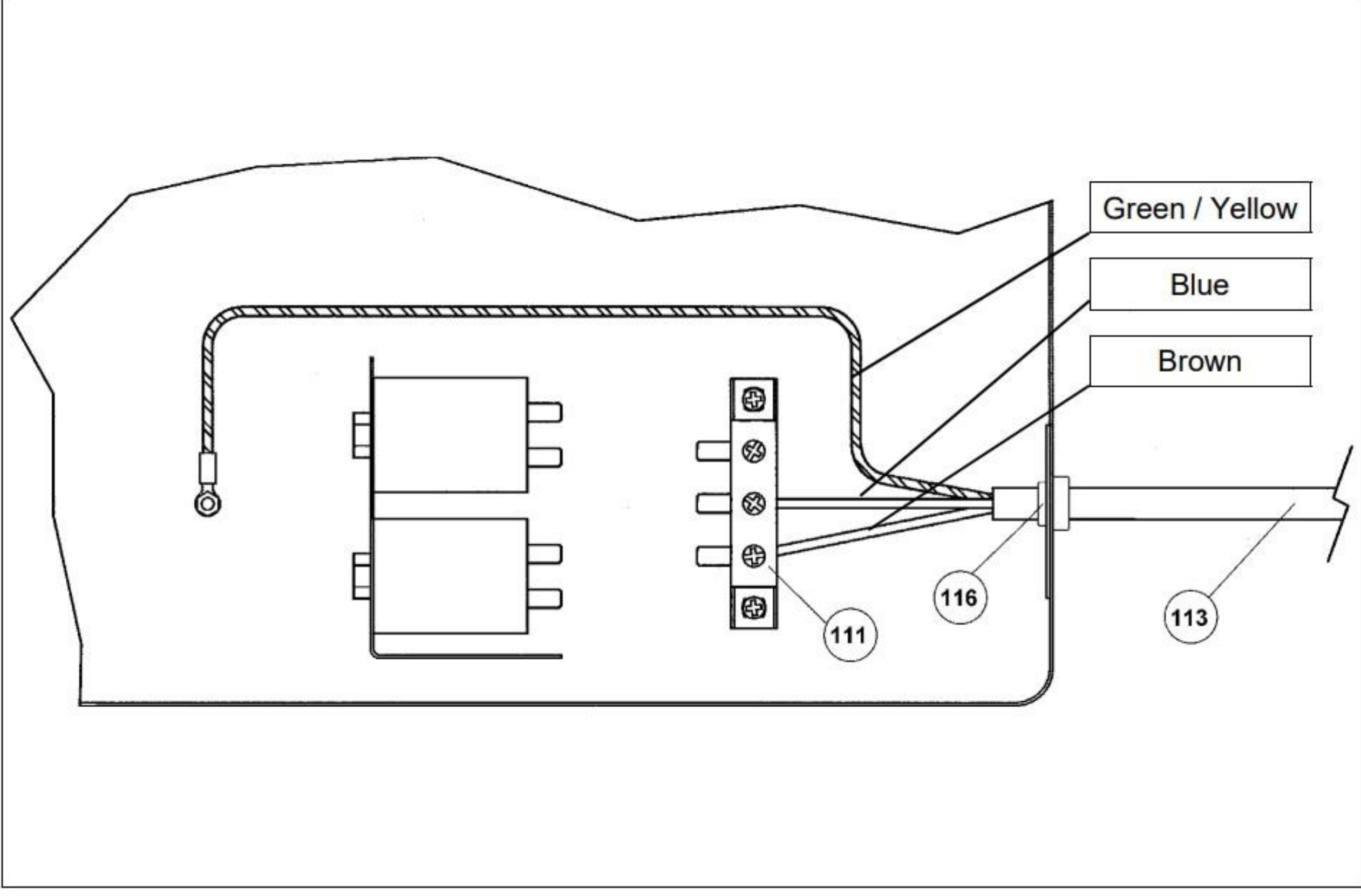

Green / Yellow

Blue

Brown

111

116

113