



REMOTE POWER PACK SERVICE MANUAL

MMPP4302-R
MMPP4302-PKG-R

MMPP4303-PKG-R
MMPP4303-PKG-3-R





MMPP4305-PKG-R
MMPP4305-PKG-3-R

MMPP4307-PKG-R
MMPP4307-PKG-3-R
MMPP4307-PKG-4-R

TABLE OF CONTENTS

EQUIPMENT SPECIFICATIONS	4-5
INSTALLATION.....	6-7
MAINTENANCE.....	8
CHANGING GLYCOL PUMP.....	9
REPLACING MOTOR.....	10
REPLACING THERMOSTAT.....	10
TROUBLESHOOTING.....	11
SPARE PARTS	12
WIRING DIAGRAMS.....	13-14
WARRANTY INFORMATION.....	15

EQUIPMENT SPECIFICATIONS





MODEL	MMPP4302-R	MMPP4302-PKG-R	MMPP4303-PKG-R	MMPP4303-PKG-3-R	MMPP4305-PKG-R
Type	Air Cooled	Air Cooled	Air Cooled	Air Cooled	Air Cooled
BTUs*	3,600	3,600	5,100	5,100	7,250
Compressor HP	1/2	1/2	3/4	3/4	1
Glycol Pumps	1	2	2	3	2
Pump Type	Rotary Vane	Rotary Vane	Rotary Vane	Rotary Vane	Rotary Vane
Pump GPH	80	80	80	80	80
Pump Motor HP	1/3	1/3	1/3	1/3	1/3
Pump Inlet/Outlet Barbs	9.52mm (3/8")	9.52mm (3/8")	9.52mm (3/8")	9.52mm (3/8")	9.52mm (3/8")
Plug Type (Bath)	5-15P 	5-15P 	6-20P* 	6-20P* 	6-20P* 
Condensing Unit Electrical Requirement	115V / 15A	115V / 15A	208/230V / 15A	208/230V / 15A	208/230V / 15A
Body Amps	5.6	11.2	3	4.5	3
Unit Amps	9.8	9.8	6.5	8	8
Refrigerant	R513a	R513a	R513a	R513a	R513a
Refrigerant Running Pressures	18 (low) / 140 (high)	18 (low) / 140 (high)	18 (low) / 140 (high)	18 (low) / 140 (high)	18 (low) / 140 (high)
Pump Unit Dimensions L x W x H Including pump(s) and motor(s)	30" x 18" x 28.5"	30" x 18" x 28.5"	30" x 18" x 28.5"	30" x 25" x 28.5"	30" x 18" x 28.5"
Weight (lbs)	71 kg / 157 lbs	71 kg / 157 lbs	80 kg / 175 lbs	91 kg / 200 lbs	98 kg / 215 lbs
Bath Capacity (gal)	11.5 gal / 43.5 L	11.5 gal / 43.5 L	11.5 gal / 43.5 L	11.5 gal / 43.5 L	11.5 gal / 43.5 L
Bath Insulation Thickness	1.5"	1.5"	1.5"	1.5"	1.5"
Inlet Water Pressure	NA	NA	NA	NA	NA
Water Inlet & Outlet Fitting	NA	NA	NA	NA	NA
Minimum Water Pipe Size	NA	NA	NA	NA	NA
Approval	ETL Listed	ETL Listed	ETL Listed	ETL Listed	ETL Listed

*Rated at 20° F evaporator temperature and 90° F ambient temperature. †.3GPM, water is only used when the temperature of the condenser rises high enough to open the cooling inlet valve. This is approximately 40% of the operating time depending on the ambient temperature and usage. Condenser Inlet Water Temperature: Minimum 45° F / Maximum 80° F.

*Units manufactured prior to 2/1/2022 were produced with a 6-15P plug. Power pack series models (MMPP4301, MMPP4302, MMPP4303 and MMPP4305) manufactured after 3/1/2023 use R513a refrigerant. Series models MMPP4307 manufactured after 1/1/2023 use R448a refrigerant.

Pump Type Pump Unit	5-15P	5-15P	6-20P	6-20P	6-20P
Voltage	115V	115V	208/230V	208/230V	208/230V
Condensing Unit Dimensions (L x W x H)	23.75" x 17.25" x 18.5"	23.75" x 17.25" x 18.5"	23.75" x 17.25" x 18.5"	23.75" x 17.25" x 18.5"	29.75" x 24.25" x 18.5"

Condensing unit does not have plug; should be direct wired.

EQUIPMENT SPECIFICATIONS				
MODEL	MMPP4305-PKG-3-R	MMPP4307-PKG-R	MMPP4307-PKG-3-R	MMPP4307-PKG-4-R
Type	Air Cooled	Air Cooled	Air Cooled	Air Cooled
BTUs*	7,250	11,500	11,500	11,500
Compressor HP	1	1 1/2	1 1/2	1 1/2
Glycol Pumps	3	2	3	4
Pump Type	Rotary Vane	Rotary Vane	Rotary Vane	Rotary Vane
Pump GPH	80	80	80	80
Pump Motor HP	1/3	1/3	1/3	1/3
Pump Inlet/Outlet Barbs	9.52mm (3/8")	9.52mm (3/8")	9.52mm (3/8")	9.52mm (3/8")
Plug Type (Bath)	6-20P* 	6-20P* 	6-20P* 	6-20P* 
Condensing Unit Electrical Requirement	208/230V /15A	208/230V /15A	208/230V / 15A	208/230V / 15A
Body Amps	4.5	3	4.5	6
Unit Amps	8	8.5	8.5	8.5
Refrigerant	R513a	R448a	R448a	R448a
Refrigerant Running Pressures	18 (low) / 140 (high)	55 (low) 260 (high)	55 (low) 260 (high)	55 (low) 260 (high)
Pump Unit Dimensions L x W x H Including pump(s) and motor(s)	30" x 25" x 28.5"	30" x 18" x 28.5"	30" x 25" x 28.5"	30" x 25" x 28.5"
Weight (lbs)	131 kg / 290 lbs	134 kg / 295 lbs	134 kg / 295 lbs	91 kg / 200 lbs
Bath Capacity (gal)	11.5 gal / 43.5 L	11.5 gal / 43.5 L	11.5 gal / 43.5 L	11.5 gal / 43.5 L
Bath Insulation Thickness	1.5"	1.5"	1.5"	1.5"
Inlet Water Pressure	NA	NA	NA	NA
Water Inlet & Outlet Fitting	NA	NA	NA	NA
Minimum Water Pipe Size	NA	NA	NA	NA
Approval	ETL Listed	ETL Listed	ETL Listed	ETL Listed

*Units manufactured prior to 2/1/2022 were produced with a 6-15P plug. Power pack series models (MMPP4301, MMPP4302, MMPP4303 and MMPP4305) manufactured after 3/1/2023 use R513a refrigerant. Series models MMPP4307 manufactured after 1/1/2023 use R448a refrigerant.

Pump Type Pump Unit	6-20P	6-20P	6-20P	6-15P
Voltage	208/230V	208/230V	208/230V	208/230V
Condensing Unit Dimensions	29.75" x 24.25" x 18.5"	29.75" x 24.25" x 18.5"	29.75" x 24.25" x 18.5"	29.75" x 24.25" x 18.5"

Condensing unit does not have plug; should be direct wired.

CONDENSING UNIT INSTALLATION STEPS

NOTICE - INSTALLATION AND SERVICE OF THE REFRIGERATION AND ELECTRICAL COMPONENTS MUST BE PERFORMED BY A REFRIGERATION MECHANIC AND LICENSED ELECTRICIAN.

DANGER – EQUIPMENT MUST BE PROPERLY GROUNDED. IMPROPER OR FAULTY HOOK-UP OF ELECTRICAL COMPONENTS OF THE REFRIGERATION UNITS CAN RESULT IN SEVERE INJURY OR DEATH. ALL ELECTRICAL WIRING HOOK-UPS MUST BE DONE IN ACCORDANCE WITH ALL APPLICABLE LOCAL, REGIONAL, OR NATIONAL STANDARDS.

The condensing unit should be located at a minimum of 18” between the face of the coil (air intake) and a wall or other vertical obstruction and have 24” clearance on the sides and air exhaust of the unit.

If mounted indoors, room should be provided with fans designed to move 1000 CFM of air per ton of refrigeration.

ELECTRICAL – Electrical power supply must match the condensing unit power requirements indicated on the unit data plate. All field wiring should be done by a licensed electrician, in accordance with all governing codes. Double check all wiring connections, including factory terminals, before startup of condensing unit.

REFRIGERANT PIPING – The condensing unit must remain sealed until piping is complete and final connections are ready to be made. Use only refrigeration grade copper tubing (ACR), Type “L”, bright annealed, dehydrated, and properly sealed against contamination. Take caution to keep refrigeration tubing clean and dry prior to installation.

Suction lines should slope down ½” for each 10 feet of horizontal run towards the compressor. If any portion of the suction line rises above the exit elevation of the evaporator (bath), p-type oil traps should be located at the base of each suction riser for proper oil return to the compressor. A properly sized filter drier and sight glass must be brazed onto the liquid side of the system downstream of the receiver.

When brazing, dry nitrogen MUST be passed through the lines at low pressure to prevent scaling and oxidation inside the tubing and fittings. All flux must be removed from joints after brazing.

Fifteen percent silver brazing wire should be used on all copper to copper connections and 45% silver brazing wire on all dissimilar metal connections.

If pressure control and fan cycle control have not been connected to the appropriate ports on the service valves, make those connections now. Make sure the pressure control settings are appropriate for the refrigerant being used.

When all refrigeration line connections have been made, the complete system should be leak checked.

EVACUATION AND START UP - A vacuum of 250 microns or less must be pulled to properly dehydrate the system.

DO NOT USE THE SYSTEM COMPRESSOR AS A VACUUM PUMP.

DO NOT OPERATE THE COMPRESSOR WHILE THE SYSTEM IS IN A VACUUM.

Open all condensing unit service valves and relieve system pressure. Also, plug in the bath to energize the liquid line solenoid valve and glycol motors on 1 and 1-1/2 HP units. GLYCOL MUST BE CIRCULATING THROUGH THE HEAT EXCHANGER IN THE BATH BEFORE THE REFRIGERATION SYSTEM IS ENERGIZED. Connect the vacuum pump to the low and high side of the system. Pull a vacuum of at least 250 microns. When 250 microns is reached, close the vacuum lines and charge the system with the proper refrigerant until the sight glass is full.

Close the low and high side service valves. Be sure that the fan cycle control and crankcase heaters are operating properly. Check thermostat on bath and be sure that temperature is dropping in the bath. When the bath temperature reaches the set point on the thermostat, the liquid line solenoid should close, suction pressure should drop and low-pressure control on condensing unit should cycle the compressor off. If unit is operating properly, replace the cover on condensing unit.

BATH INSTALLATION STEPS

(Assure tower connections are complete.)

1. Remove the refrigeration deck from the unit.
2. Inspect the glycol tank for any debris.
3. Connect one of the glycol lines from the trunk line to the pump outlet. Insulate any exposed tubing.

NOTE: In units with more than one pump, connect a glycol line to each pump outlet.

4. Connect the second glycol line from each circuit to the glycol bath inlet.
5. Fill the glycol bath with **Micro Matic Polar Flo®** glycol solution:
 - MMPP4302-R, MMPP4302-PKG-R, MMPP4303-PKG-R, MMPP4303-PKG-3-R.

Mix: 2 ½ parts water to 1-part glycol.

- MMPP4305-PKG-R, MMPP4305-PKG-3-R, MMPP4307-PKG-R, MMPP4307-PKG-3-R, MMPP4307-PKG-4-R

Mix: 7 parts distilled water to 5 parts glycol.

Fill bath to the level of the fill line on the glycol level indicator.

6. Replace the refrigeration deck.
7. Connect electrical outlets capable of handling the required voltage loads. This should be carried out by suitably trained personnel and must comply with all state and national codes.
8. Glycol level will fall as glycol is pumped through the glycol lines. Continue to fill the bath to the full level on the glycol level indicator. **Series MMPP4305 and MMPP4307 pumps must be circulating before compressor is started.**
9. Inspect for any leaks.

NOTE: To adjust the glycol temperature, please see Adjusting Electronic Thermostat.

MAINTENANCE

1. Inspect the unit monthly to ensure that the glycol level is maintained to the full level.
2. If the level is low replace with a **Micro Matic Polar Flo®** glycol solution:
 - MMPP4302-R, MMPP4302-PKG-R, MMPP4303-PKG-R, MMPP4303-PKG-3-R.

Mix: 2 ½ parts water to 1-part glycol.

 - MMPP4305-PKG-R, MMPP4305-PKG-3-R, MMPP4307-PKG-R, MMPP4307-PKG-3-R, MMPP4307-PKG-4-R,

Mix: 7 parts distilled water to 5 parts glycol.
3. If there is evidence of ice buildup in the unit, allow the ice to melt and replace all the water/glycol solution with a fresh solution mixed per above instructions.
4. The glycol/water solution should be changed approximately every 18 months. In regions of high humidity considerations should be given to replacing the solution on an annual basis.
5. Check and clean the condenser fins every sixty (60) days.
6. Check that there is adequate air flow through the unit ensuring enough space all around and that there are no obstructions in front of the air flow vents.
7. Check the condition and effectiveness of the trunk line insulation.
8. At regular intervals, to be determined by the owner, the unit should be checked for electrical safety.

ELECTRONIC TEMPERATURE CONTROL WITH DISPLAY

NOTE: When the unit leaves the factory, the electronic thermostat is pre-set to the following parameters:

Temperature Scale:	F (Fahrenheit)
Setpoint:	29° F
Differential:	3° F

SERIES MMP4305 AND MMPP4307

Temperature Scale:	F (Fahrenheit)
Setpoint:	28° F
Differential:	5° F

NOTE: To ensure the correct operation of your unit these parameters must be adhered to.



User/customer can change the temperature by pressing the up and down arrows.

CHANGING GLYCOL PUMP

Note: A pinch off tool is required to complete this repair

1. Unplug unit from receptacle.
2. Pinch off glycol supply line to bottom of pump allowing enough room to remove clamp safely.
3. Hold pump firmly and loosen clamp between pump and motor.
4. With clamp loose remove pump and drive key.
5. Install new key and pump by reattaching clamp making sure alignment of key is correct between pump and motor.
6. Reattach glycol supply hose and install clamp.
7. Remove pinch off tool and plug unit into receptacle.

REPLACING MOTOR

1. Unplug unit from receptacle.
2. Support pump and loosen clamp holding pump to motor. As clamp is loosed pump will eventually disconnect from motor. Make sure pump does not damage glycol supply line as it becomes free from motor.
3. With pump free from motor remove drive key and replace.
4. While supporting motor remove four (4) nuts and hardware from mounting studs.
5. Mount new motor by aligning mounting bracket with mounting studs and reattaching mounting nuts and hardware. **Note: new motor is supplied with mounting bracket.**
6. Reattach pump to motor with clamp making sure new drive key aligns with motor shaft.
7. Locate defective motor and remove electrical connection cover plate (follow cord to where it enters back of motor) exposing cord connections. Remove ground connection by unscrewing green screw and removing ground wire. Unplug remaining 2 wires by pulling firmly on connections. Reattach cord to new motor by affixing ground wire to green ground screw and plugging 2 wires to motor connections. Place cord in electrical wire channel in motor housing and reattach electrical connection cover plate.
8. Plug cord into receptacle.

REPLACING A DANFOSS THERMOSTAT

1. Unplug power pack
2. Insert a small flat head screwdriver between the thermostat faceplate and the panel and twist the screwdriver at the top, bottom, and ends of the faceplate to remove the faceplate.
3. After the faceplate is removed, slide the thermostat forward through the mounting hole.
4. Remove the wires from the slip on terminals and the temperature probe from the back of the thermostat.
5. Insert the yellow wire on terminal one, black wire on terminal two, white wire on terminal three. The temperature probe flat plug will push into s1 on the new thermostat.
6. Slide the thermostat back into the mounting hole and snap the faceplate onto the thermostat.

TROUBLESHOOTING

TROUBLE		CAUSE		SOLUTION	
1.	Excessive foam	A.	Warm walk-in cooler	A.	Adjust cooler temperature to 36° to 38° F (use a quality thermometer)
		B.	Check applied pressure to keg	B.	Adjust setting on regulator for proper flow rate of two (2) ounces per second.
		C.	Check equipment	C.	Check the physical equipment from keg to faucet
		D.	Warm product lines	D.	Refer to #5
2.	Compressor does not start (no hum), but the fan motor runs.	A.	Compressor relay or capacitor malfunction	A.	Replace compressor relay or capacitor
		B.	Inadequate voltage	B.	Measure voltage across common and run terminal on compressor. Voltage must not drop below 90% of rated voltage.
		C.	Compressor failure	C.	Replace compressor
	Compressor starts and continues to run until freeze up and will not cut off.	A.	Thermostat control failure	A.	Replace thermostat
B.		Freon leak	B.	Repair leak and recharge	
4.	Compressor does not run but hums.	A.	Inadequate voltage	A.	Measure voltage across common and run terminal on compressor. Voltage must not drop below 90% of rated voltage.
		B.	Starting relay malfunction	B.	Replace starting relay. Be sure to use correct relay. Failure to use correct relay will cause compressor failure.
		C.	Compressor malfunction	C.	Replace compressor
5.	Warm beer	A.	Defective Pump (check motor also)	A.	Check return line in reservoir for liquid flow. Replace pump on 125', 250', and 500' units. Check condition of key between pump and motor.
		B.	Defective motor (check pump also)	B.	Replace motor
		C.	Refrigeration unit not running	C.	Refer to #2
		D.	Trunk lines located in overheated area	D.	Remove from any hot water pipes or kitchen area with stove or glass washer.
		E.	Trunk lines flooded in PVC chase.	E.	Remove lines from PVC, thoroughly dry PVC and repair or replace trunk line as needed.
		F.	Uninsulated or poorly insulated lines	F.	All lines should be fully insulated from cooler into dispenser. Includes glycol lines from power pack into cooler.
		G.	Thermostat	G.	Adjust temperature to colder setting.
		H.	Condenser fan motor not working	H.	Replace condenser fan motor
		I.	Freon Leak	I.	Repair leak and recharge
		J.	Dirty condenser	J.	Clean the condenser
		K.	Condensation inside trunk line insulation (may be caused from cleaning lines)	K.	Check trunk housing in areas for drooping or low spots, split insulation approximately 5" and separate. Allow any water to drain, then air dry the seal closed.

TYPICAL SPARE PARTS

COMPONENT	PART NUMBER	MMPP4301-EP	MMPP4301	MMPP4302	MMPP4303	MMPP4305	MMPP4307
Vane Pump and Motor Assembly	MMPP4301-PPM		X	X			
Pump Insulation	MM-IPCPR0		X	X	X	X	X
Vane Pump Assy	PP4301-PPA		X	X	X	X	X
Motor (1/3 HP)	MMPP4301-M		X	X			
Motor (1/3 HP 220 Volt)	MMPP4305-M				X	X	X
Vane Pump Key	MM-3362-2		X	X	X	X	X
Clamp, Pump Connectors	MM-BC3-KIT		X	X	X	X	X
Nipple for Vane Pump-Straight	617C		X	X	X	X	X
Vertical Pump	MMPP4301-EPVP	X					
Thermostat Danfoss ERC 112C	MMPP080G3206	X	X	X	X	X	X
Compressor MPP4301 Series	MMPP4301-EP-C	X	X				
Refrigeration Deck MPP4301 Series	MMPP4301-UPPER		X				
Refrigeration Deck MPP4302 Series	MMPP4302-UPPER			X			
Compressor MPP4302 Series	MMPP4302-C			X			
Compressor MPP4303 Series	MMPP4303-C				X		
Compressor MPP4305 Series	MMPP4305-C					X	
Compressor MPP4307 Series	MMPP4307-C						X
On/Off Power Switch	MMPP4301-SW-P		X	X	X	X	X

4301-PKG REMOTE WIRING DIAGRAMS

NUMBER OF MOTOR RECEPTACLES MAY VARY

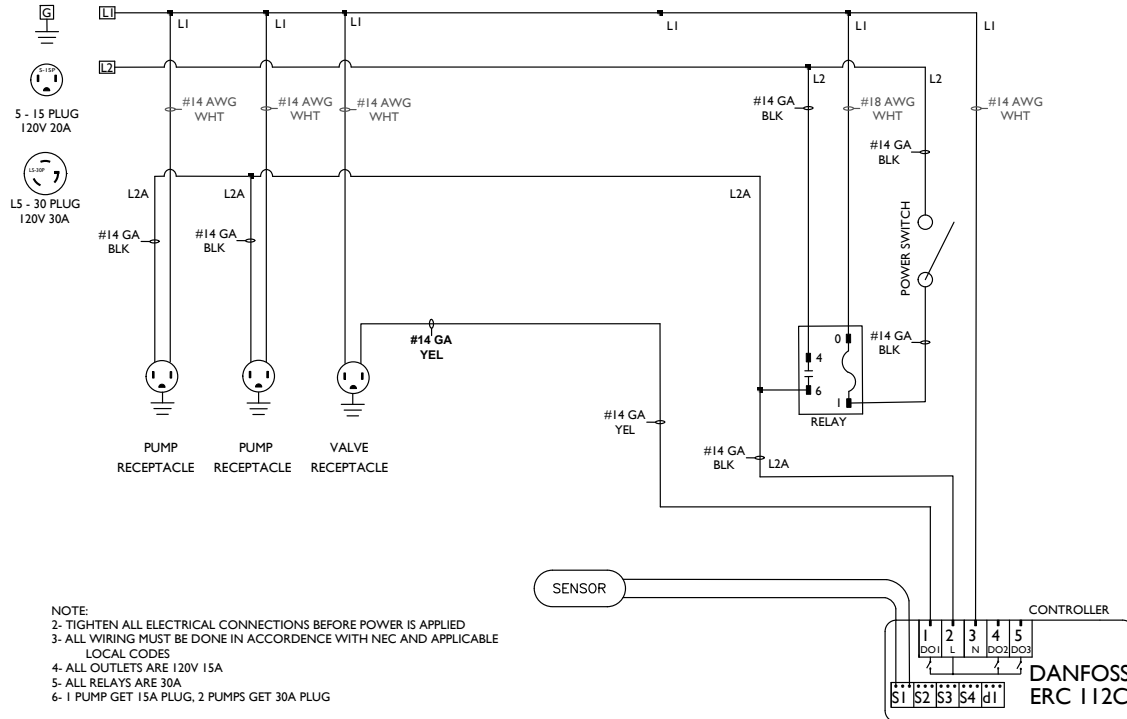

4302 REMOTES WIRING DIAGRAMS

NUMBER OF MOTOR RECEPTACLES MAY VARY

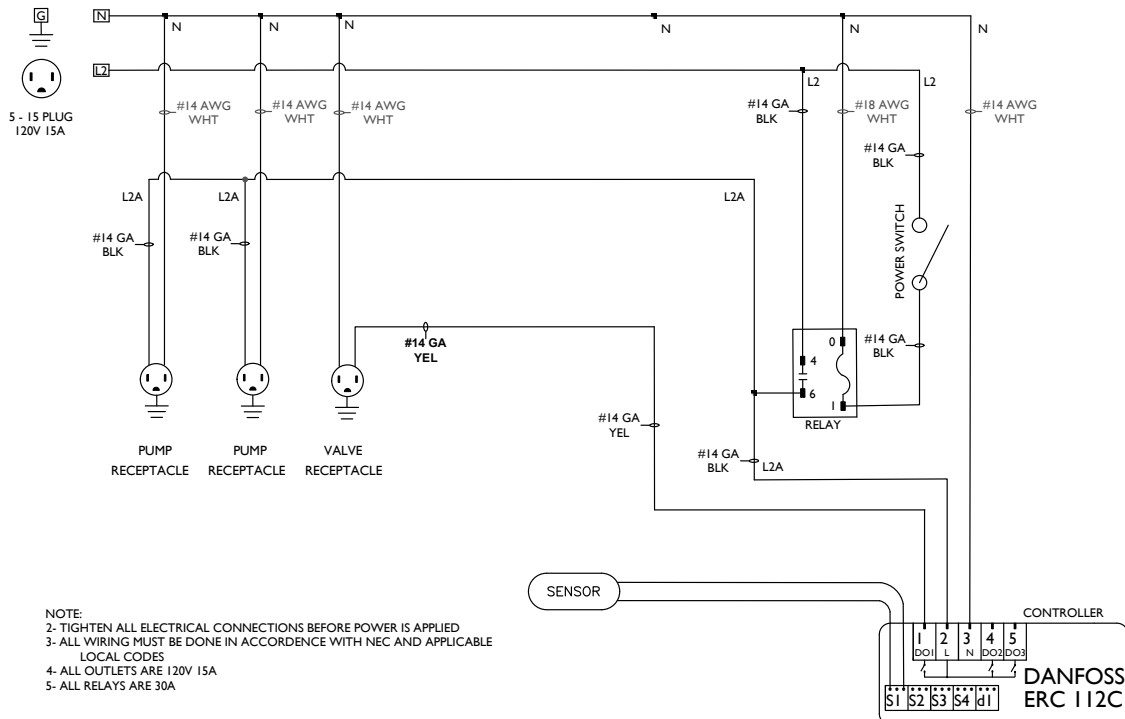

4303/05/07 REMOTES WIRING DIAGRAMS

NUMBER OF MOTOR RECEPTACLES MAY VARY

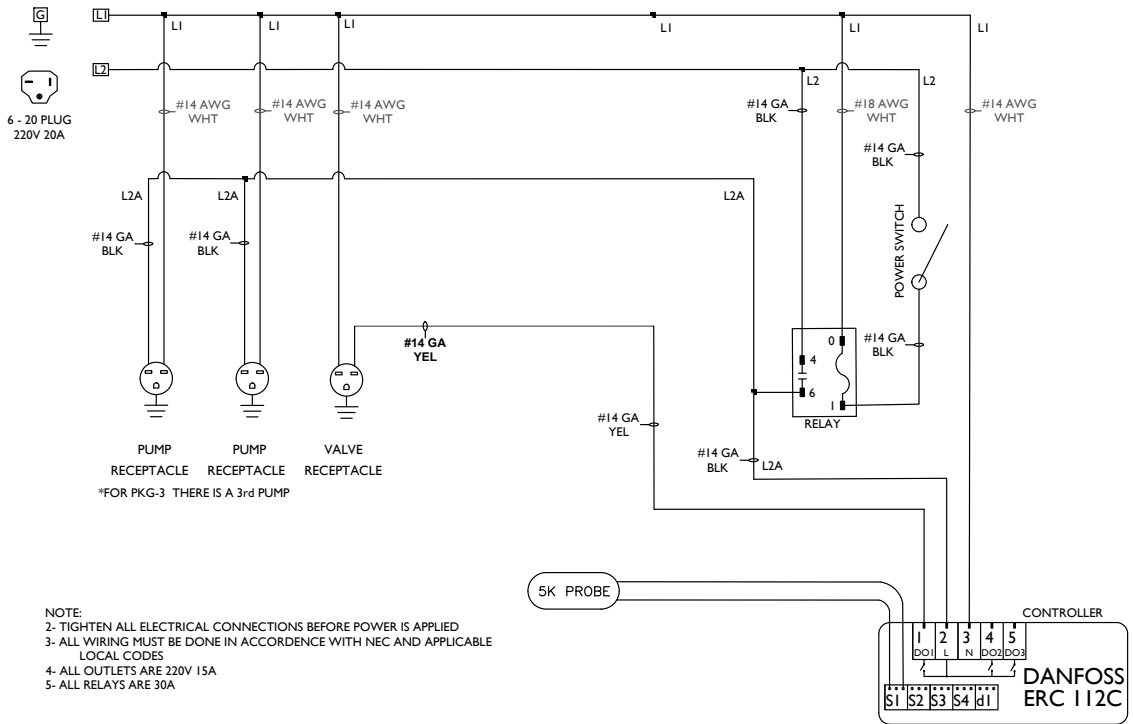

COMPRESSOR DIAGRAM

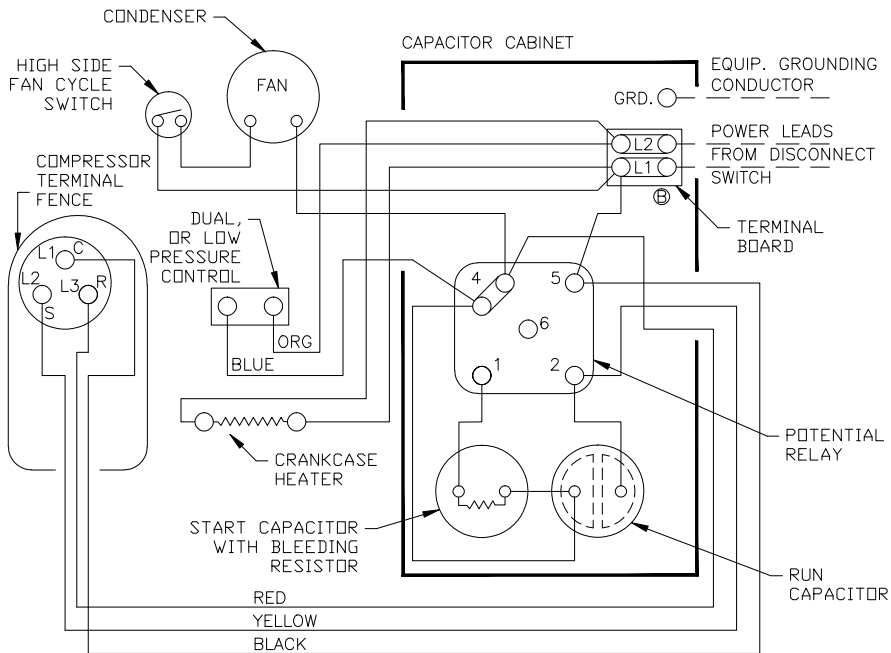

IMPORTANT: COMPRESSOR EQUIPPED WITH AN INTERNAL OVERLOAD PROTECTOR. ALLOW TIME FOR RESET.

WARRANTY

All power packs carry a full warranty against defects in material and workmanship for a period of eighteen (18) months on parts and one (1) year on labor. The compressor is warranted for an additional three and one-half (3-1/2) years. All loss of sales must be borne by the purchaser.

WARRANTY CLAIMS PROCEDURE

Purchaser shall notify Micro Matic of any defect discovered in the Product during the Warranty Period and obtain a return authorization number. Purchaser must ship the Product per Micro Matic's instruction. After receipt of the Product, Micro Matic shall, at its option, repair (or authorize the repair of) or replace Products found by Micro Matic to be defective. Micro Matic's determination of defects is final. Failure by Purchaser to give notice of claims of breach of warranty within the Warranty Period shall be deemed an absolute and unconditional waiver of Purchaser's claim for such defects. Products repaired or replaced during the Warranty Period shall be covered by the foregoing warranties for the remainder of the original Warranty Period.

ALL REPAIRS MUST BE FIRST AUTHORIZED BY MICRO MATIC PER THE ABOVE PROCEDURE. UNAUTHORIZED REPAIRS WILL NOT BE REIMBURSED BY MICRO MATIC UNDER ANY CIRCUMSTANCES.

Micro Matic is not responsible for parts damaged from factors including, but not limited to any part that has been subject to misuse, neglect, alteration, accident, unauthorized service, abuse, or any damage caused by transportation. This warranty does not cover items subject to normal wear and tear (gaskets, seals, O-rings, etc.).

PURCHASER RESPONSIBILITY

Except as expressly provided in this Agreement, Purchaser assumes all other responsibility for any loss, damage, or injury to persons or property arising out of, connected with, or resulting from the use of Products, either alone or in combination with other products or components. In no event will Micro Matic be responsible for incidental, consequential, or punitive damages of any kind, including, without limitation, claims for loss of beer, loss of gas, or loss of sales.

OTHER WARRANTIES DISCLAIMED

These are the sole and exclusive warranties and conditions given by Micro Matic with respect to the products and services and are in lieu of and exclude all other warranties or conditions, express or implied, arising by operation of law or otherwise, including without limitation, warranties of merchantability, fitness for a particular purpose and non-infringement, whether or not the purpose of use has been disclosed to Micro Matic in specifications, drawings or otherwise, and whether or not Micro Matic's products are specifically designed and/or manufactured by Micro Matic for purchaser's use or purpose.

LIMITATION OF REMEDY

Purchaser's sole and exclusive remedy for breach of any warranty or condition under this Article IV shall be limited to the repair, correction or replacement, of the defective Products.

