

mart cart®

OWNER'S MANUAL



Effective Date:



Mart Cart®
Model #02002

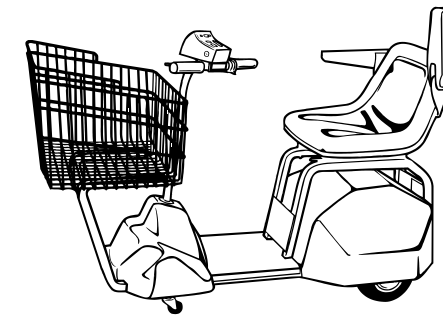

MARTMATE™
Model #01001-M

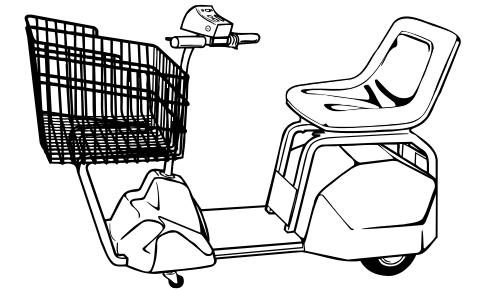

Mart Shopper™
Model #01001-MS

mart cart®

Is a quality product line of
Assembled Products™ Corporation

1-800-548-3373

115 E. Linden · Rogers, Arkansas 72756 USA
Phone: (479) 636-5776 · Fax: (479) 636-3245
Web site: www.martcart.com

CONGRATULATIONS

You have just purchased the best electric shopping cart on the market today. The models #02002 and #01001 incorporate the very latest in technological advances. To assure you of the best and safest performance as well as longest life, please read the enclosed information.

After reading this manual, should you have a service problem or need help, please call our customer service department with the serial number of your cart, at our toll free number: (800) 548-3373 or (479) 636-5776.

TO ORDER PARTS CALL: (479) 636-5776 OR (800) 548-3373

Be sure to give the serial number to the service department personnel. This number is located on the rear body of the Mart Cart as shown in Figure #3 of this manual. The MARTMATE and Mart Shopper serial number is located on the seat support tube under the seat.

TERMS: All parts will be shipped with check in advance or C.O.D. Commercial accounts are allowed 15 day terms from date on invoice with approved credit.

FREIGHT: All freight will be paid by the customer. Special consideration will be given to items under warranty coverage.

IMPORTANT DOCUMENT — DO NOT DISCARD

Serial Number:

Dated Shipped:

NOTE: Specifications found in this manual subject to change without notice.

FOR COMMERCIAL USE ONLY. NOT FOR PERSONAL USE.

TROUBLE SHOOTING

Caution: Wall socket (electrical outlet) used for battery charging should have a ground fault circuit interrupter installed by a licensed electrician.

Tools required: Screwdrivers-blade & phillips; socket set — 7/16", 1/2", 9/16"; box or open-end wrenches — 7/16", 1/2", 9/16"; allen wrenches — 3/32", 1/8", 5/32", 3/16"; small crescent wrench; vice-grips; soldering gun, flux and solder; electric drill and bits, wire cutters, strippers and crimper; voltage-ohm meter with continuity checker; spray cleaner (Appliance magic for counter tops & plastics); clean rags; lps#1 lubricant, heavy duty grease.

- Charger must be unplugged to perform most tests. Power light, "FWD" or "REV" lights, and led bar light will work when charger is plugged in, but array of battery indicator lights will not work.
- To confirm motor and PWN controller operation, block the drive wheel off the floor and actuate the throttle while connecting a jumper wire from chassis ground to the green (FWD) or white (REV) wire at the pwm controller (Separate connector). If wheel turns but cart would not operate in normal fashion, above components are OK, but circuit board is suspect.
- To check battery (Charge for 6 hours minimum before hand), block drive wheel off floor, connect volt-ohm meter to battery, and actuate throttle at full speed. Reading should be 10.5 volts or higher.

Symptom	Possible Cause	What To Do
1. Cart won't go with soft-touch pad in "FWD" or "REV" when actuating throttle.	1. Broken or weak throttle spring or broken linkage. 2. Lose set screw on throttle plate. 3. Improper adjustment of throttle linkage. 4. Improper adjustment of potentiometer. 5. Bad circuit board.	1. Replace throttle linkage. 2. Tighten, adjust cable. 3. Adjust per instructions. 4. Adjust per instructions. 5. Replace circuit board.
2. Cart stops when making right or left turn.	1. Broken wire in harness where it exits steering column. 2. Low battery.	1. Replace wire harness kit. 2. Charge battery.
3. Cart won't go at all, throttle system is O.K.	1. Broken wire harness. 2. Weak battery. 3. Defective old battery. 4. Open circuit breaker. 5. Safe-T-Stop faulty. 6. Seat switch not depressed. 7. PWM defective. 8. Charger is defective.	1. Replace wire harness kit. 2. Change battery. 3. Replace with new battery. 4. Reset circuit breaker. 5. Examine and repair. 6. Operator must be fully seated. 7. Replace PWM. 8. Replace charger.
4. Cart won't go, throttle system OK wiring harness OK, battery weak.	1. Loose wire(s) in cord reel or defective contacts. 2. Loose wire in control box. 3. Loose wire at key switch. 4. Battery terminal loose. 5. No power at wall socket. 6. Faulty battery charger.	1. Replace reel as necessary. 2. Tighten/reconnect. 3. Tighten/reconnect. 4. Tighten/reconnect. 5. Check for 110 volts. 6. Replace battery charger.
5. Cart goes but only at higher speed when throttle is at or near full "ON".	1. Broken or cracked winding on potentiometer. 2. Throttle spring broken. 3. Faulty PWM controller.	1. Replace potentiometer. 2. Replace throttle spring. 3. Replace PWM.
6. Battery won't take a charge. Cart quits part way through shopping, after charging all night.	1. Defective or old battery. 2. Defective charger. 3. See 4(1) above. 4. Defective line cord, plug. 5. No power or wrong voltage at wall socket.	1. Replace battery. 2. Light on charger should come on. 3. See 4(1) above. 4. Replace. 5. Test , try different socket.
7. Cart goes, but only at low speed, for short duration with above conditions ruled out.	1. Weak battery. 2. Tire rubbing on body. 3. Bad armature kit. 4. Potentiometer not reaching full "ON" position. 5. Drive belt loose. 6. Power cord wrapped around tire. 7. Defective wheel bearing.	1. Charge or replace. 2. Check wheel bearing or axle. 3. Replace. 4. Adjust throttle plate. 5. Tighten. 6. Replace and test cord. 7. Replace bearing.
8. Cart won't go or move intermittently or a grinding noise originates from motor.	1. Motor gear broken. 2. Bad armature. 3. Motor bearing worn out. 4. Pulley set screw or key loose or missing. 5. Drive belt loose.	1. Replace gear or motor assembly. 2. Replace armature. 3. Replace motor assembly. 4. Tighten set screw or replace key. 5. Adjust belt Idler tension to 1/2" to 3/4" belt deflection.
9. Cart won't go or operates in only "FWD" or only "REV". Above conditions ruled out.	1. Defective Soft-Touch Pad, PWM Controller, or PC Board. 2. Safe-T-Stop faulty. 3. Defective potentiometer.	1. Replace. 2. Examine and repair. 3. Replace.
10. Battery condition LED won't operate.	1. Loose wiring. 2. Low battery. 3. Defective circuit board 4. Key switch not turned on. 5. Not properly "seated". 6. Open Circuit Breaker (5 amp).	1. Tighten/reconnect. 2. Charge. 3. Check with volt meter/replace. 4. Turn key switch on. 5. Become fully seated. 6. Reset Circuit Breaker.
11. Seat won't slide easily.	1. Worn track. 2. Seat-lock engaged.	1. Replace seat sliding mechanism. 2. Hold locking lever to the left while trying to slide.
12. Cart moves while cart is plugged in.	1. Faulty PWM. 2. Faulty cord reel. 3. Faulty charger. 4. No power to outlet.	1. Replace PWM. 2. Replace cord reel. 3. Replace charger. 4. Check for 110.
13. Cart has power with or without key switch on or seat switch activated.	1. Faulty circuit board. 2. Check bad connection.	1. Replace circuit board. 2. Check key switch and seat switch wires
14. Cart has no tension in the throttle.	1. Broken throttle spring. 2. Broken throttle linkage.	1. Replace throttle spring. 2. Replace throttle linkage.

— Important Safety Instructions —

Please read before operating

WARNINGS

- Never attempt to charge the battery in this cart without using an electrical outlet that is protected by a GFCI, (Ground Fault Circuit Interrupter).
- Replace complete cord reel if either it or the charging cord or plug is damaged or if the cord is worn or frayed.
- Never use the charging cord without proper grounding. Do not use if plug does not have three terminals.
- Never allow the cart to be used out-of-doors or on any surface that is not level.
- Always disconnect power before servicing.
- See page 4 "Daily Maintenance Checklist" and follow instructions.

RECOMMENDED OPERATING PROCEDURES

- This cart is for use indoors on level surface only.
- Standing on cart is permitted providing the operator stands in the center only. **DO NOT STAND WHILE CART IS MOVING.** Be certain all switches are in the "OFF" position before standing. (See "Operating & Warning Instructions" on cart).
- After battery is charged, disconnect power supply cord before operating cart.
- **DO NOT** exceed the load limitations as shown on the cart.
- **DO NOT** force power supply cord into the rear housing of cart. Follow posted operating instructions.
- **DO NOT** allow children to operate or play on cart. Keep cart secured with key at service counter or offer "Key Club" program (see back cover).

FREIGHT DAMAGE

CHECK:

- The shipping carton for any visible damage. Report the damage to the freight carrier immediately. File a claim with the carrier if actual damage to your cart has occurred.
- Contents of the carton. The contents should agree with the information listed on the packing list. Report any discrepancy to the carrier and the factory immediately.

ATTENTION

- It is the responsibility of the owner of this cart to maintain the cart in a safe and reliable operating condition at all times.

DAILY MAINTENANCE CHECK LIST

For optimum cart availability and performance, the following items should be checked daily:

- **ELECTRIC CORD and/or REEL**—Replace cord reel if cord is worn or frayed, 3 pronged plug is broken or reel will not retract. Be sure power outlet provides protection through an operating “Ground Fault Circuit Interrupter” (GFCI).
- **SEAT AND MOUNTING**—Tighten if necessary. If cracks or rust occur, or if seat rocks loosely, replace at once. Lubricate tracks with Vaseline as required. Make sure Seat Lock is in good working condition.
- **SEAT SWITCH**—Test and replace if not working properly. Cart must stop when weight is removed from seat.
- **THROTTLE**—Test for smooth “start, acceleration, deceleration, and stop.” Repair if necessary. Charge or replace battery if needed.
- **ANTI-TIP CASTERS**—Replace if broken. Maintain height adjustment of 3/8" to 1/2" above floor level.
- **BRAKES**—Test to be sure cart stops.
- **GENERAL**—Repair or replace any component that would cause a potential safety hazard.
- **APPEARANCE**—Wipe off and clean as needed for customer satisfaction and for stores public image.

BATTERY CHARGING

- Install a Ground Fault circuit interrupter (GFCI) in the electrical circuit wherever the cart is to be charged. This is to protect against any possible shock hazard.
- AC voltage required is 120V AC. The current draw is 1.5 amps. The charger output will be below 6 amps, DC, to the battery.
- **Charge battery nightly after daily use.** When the battery is fully charged, the charger will maintain a “float voltage” which will not damage the battery.
- One complete charge will allow up to 5 days of normal grocery operation before battery is completely discharged. A fully discharged battery will take 20 hours to fully charge, so it is best not let the battery become completely discharged.
- **Do not store the cart with a discharged battery for more than 30 days, as this can cause premature battery failure. Fully charge the battery at least every 30 days, if in a low usage location.**
- To determine if the charger is working properly, remove the rear cover, plug the charger into a GFCI protected line. The Charger light should be yellow, if charging, and green if the battery indicates fully charged. The red light indicates the charger is plugged in.
- No maintenance of battery is required. The battery is maintenance free, and water cannot be added.

Note: Under normal conditions, the battery will last 18 months or longer if the above recommendations are followed. Replace with only original Mart Cart Battery. Mart Cart is not responsible for any adverse effects caused by replacement with any other type of battery.

MART SHOPPER LABELS

• Replace labels if **Damaged, Lost or Unreadable!**

USE INDOORS ON LEVEL SURFACE ONLY.
DO NOT REMOVE FROM STORE.
200-1764

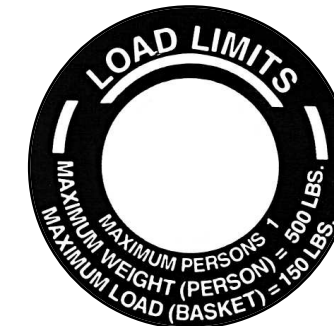

For information about
Owning your own
PERSONAL SCOOTER
by Mart Cart*
Call 1-800-548-3373 / 501-636-5776
www.assembledproducts.com 200-3327-02

BATTERY CHARGER
120 VOLTS-INPUT-1.5 AMPS
RECOMMENDED CHARGE CYCLE
NOT TO EXCEED 16 HOURS
DISCONNECT
BEFORE OPERATING CART



WARNING
FOR INDOOR USE ONLY
TO PREVENT PERSONAL INJURY FROM ELECTRICAL SHOCK - **DO NOT USE CHARGING CORD IF:**
1) THE ELECTRICAL OUTLET IS NOT PROTECTED BY A GROUND FAULT CIRCUIT INTERRUPTER (GFCI).
2) THE ELECTRICAL CORD OR PLUG IS DAMAGED OR WORN. REPLACE BEFORE USING WITH ONLY 3 WIRE CORD AND PLUG OF SAME TYPE.

DAILY MAINTENANCE CHECK LIST
For optimum Cart availability and performance, the following items should be checked daily:

1. **ELECTRIC CORD and/or REEL** - Replace cord-reel if cord is worn or frayed, 3 pronged plug is broken or reel will not retract. Be sure Power-Outlet provides protection through an operating Ground Fault Circuit Interrupter (GFCI)
2. **SEAT & MOUNTING** - Tighten if necessary. If cracks or rust occur, or if seat rocks loosely, replace at once. Lubricate swivel or tracks with vaseline as required. Make sure Seat Lock is in good working condition.
3. **SEAT SWITCH** - If cart is equipped with a seat switch, test and replace if not working properly. Cart must stop when weight is removed from seat.
4. **THROTTLE** - Test for smooth "start", acceleration, deceleration and "stop". Replace cable or grip if necessary. Charge or replace battery if needed.
5. **ANTI-TIP CASTERS** - Replace if broken. Maintain height adjustment of 3/8" to 1/2" above floor level.
6. **GENERAL** - Repair or replace any component that would cause a potential "Safety Hazard".
7. **APPEARANCE** - Wipe off and clean as needed for customer satisfaction and for store's "Public Image".

FOR PARTS OR SERVICE CALL
800-548-3373 or 501-636-5776
200-1127-01

OPERATING INSTRUCTIONS
PLEASE READ BEFORE OPERATING

1. ADJUST AND LOCK SEAT (SOME CHAIRS DO NOT HAVE A SEAT LOCK). SEE "WARNING". USE EXTRA CAUTION.
2. IF CART HAS A KEY SWITCH, TURN POWER ON BY ROTATING KEY. (SOME CARTS TURN ON AUTOMATICALLY WITH THE OCCUPANT SEATED.)
3. SELECT FORWARD OR REVERSE.
4. TWIST HAND-GRIP SLOWLY TO INCREASE SPEED - RELEASE TO STOP.
5. TO STOP IN AN EMERGENCY: RELEASE HAND GRIP; OR TOUCH "OFF" BUTTON; OR TURN OFF KEY SWITCH IF APPLICABLE;
6. STOP CART COMPLETELY BEFORE CHANGING DIRECTIONS.
7. RETURN CART TO STARTING POINT WHEN DONE.
8. LEAVE ALL SWITCHES IN THE "OFF" POSITION,
9. EXIT WITH CARE. SEE "WARNING". ASK FOR HELP IF NEEDED.

280-1037-02 MM

WARNING
PLEASE READ TO AVOID PERSONAL INJURY

1. USE AT YOUR OWN RISK. READ OPERATING INSTRUCTIONS. IF YOU ARE NOT FAMILIAR WITH THIS CART ASK FOR ASSISTANCE BEFORE USING.
2. BE SURE CHARGER CORD IS UNPLUGGED BEFORE USING.
3. SHUT POWER "OFF" AND USE EXTRA CAUTION BEFORE ENTERING OR EXITING SEAT.
4. YOU MUST BE SEATED TO OPERATE CART. KEEP FEET AND LEGS INBOARD WHILE OPERATING.
5. TO AVOID TIPPING, STAND ONLY IN CENTER OF CART. DO NOT LEAN ON OR OVER SIDE OF CART. SHUT POWER "OFF" & SET PARKING BRAKE WHEN STANDING.
6. USE INDOORS ON LEVEL SURFACE ONLY.
7. NO CHILDREN IN BASKET.

MM

THROTTLE LINKAGE REPLACEMENT

For the Mart Cart, MARTMATE and Mart Shopper

1. Turn off key switch.
2. Remove control box cover. Refer to figure #1. Examine linkage, adjust or replace as necessary.
3. To free the ball end of the linkage, the inner throttle tube (See Figure #2) must be rotated towards the front of the cart. This may be done by removing the upper and lower clamp halves.
4. Rotate the inner throttle tube forward until the ball end of the linkage is visible and removable.
5. Disconnect the other end of the linkage from the throttle plate. (Figure #1)
6. Install new linkage by inserting ball end into hole and slot of inner throttle tube. Be certain cable is in slot. Hold hand tension on cable while rotating throttle grip backwards so as to spool up linkage around inner throttle tube. The linkage should wrap around inner throttle tube about 3/4 turn.
7. Re-install clamp halves on throttle grip. Be certain that flat handles on grips are parallel to control box mounting plate
8. Attach other end of linkage to throttle plate. Secure with flatwashers and "E" ring.
9. Twist the throttle grip to test the throttle actuation and security of the linkage to the inner throttle tube and throttle.
10. Turn on key switch and test cart for proper operation. The motor circuit should be activated after an approximate 35-40 degree twist of the grip.
11. The potentiometer may require resetting for accurate throttle response. This may be accomplished by loosening the set screw in collar of throttle plate, it should be adjusted to allow the throttle grip to rise 35-40 degrees before the motor circuit is activated. Test throttle linkage with throttle in full "ON" position. The cable should still be able to be depressed slightly. (This assures that the potentiometer is not in danger of breaking its internal stop). Make sure cart stops when throttle is released.
12. After final inspection, reassemble the control box, being sure that all wires are tucked up and out of the way of the new throttle linkage.

FIGURE 1

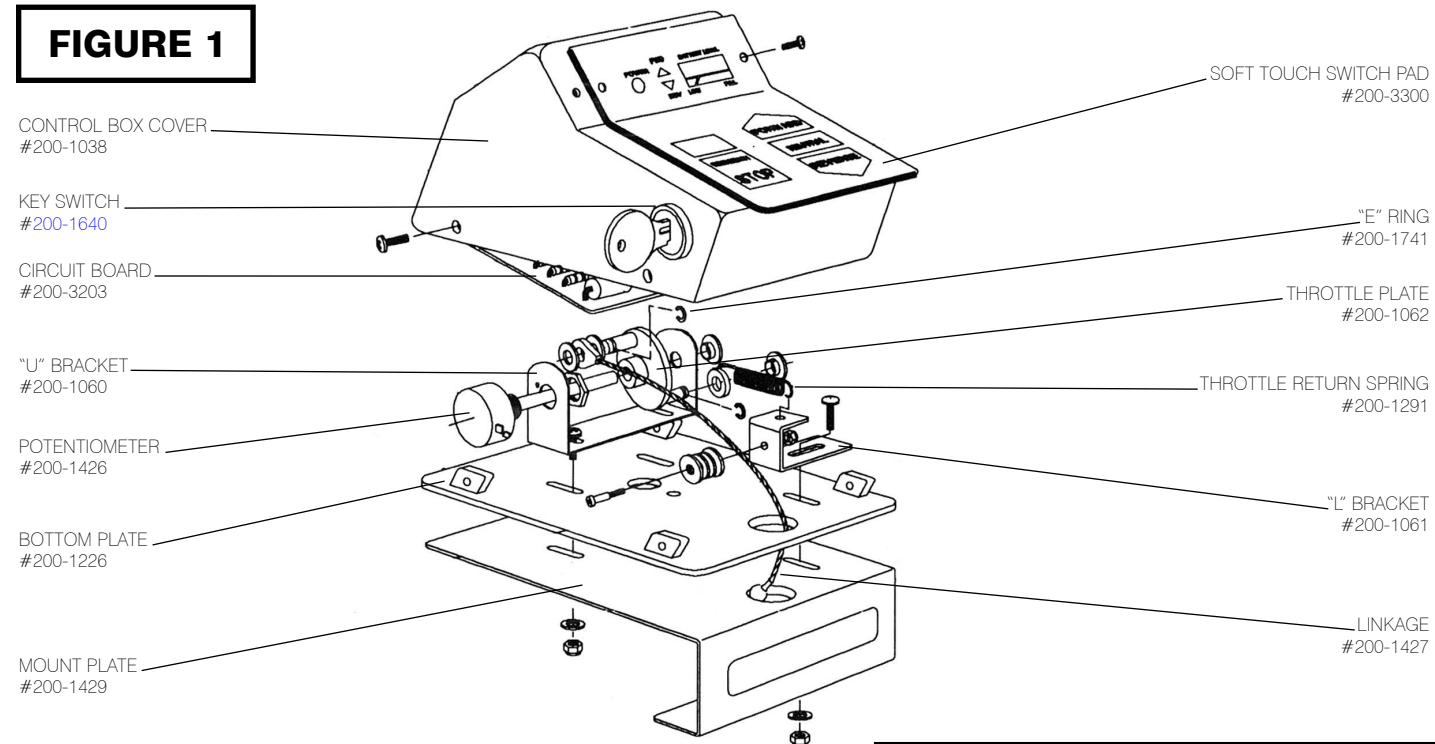

Mart Cart & MARTMATE

IMPORTANT: Check Throttle Return Spring for wear...replace If worn.

MART SHOPPER EXPLODED VIEW

FIGURE 7

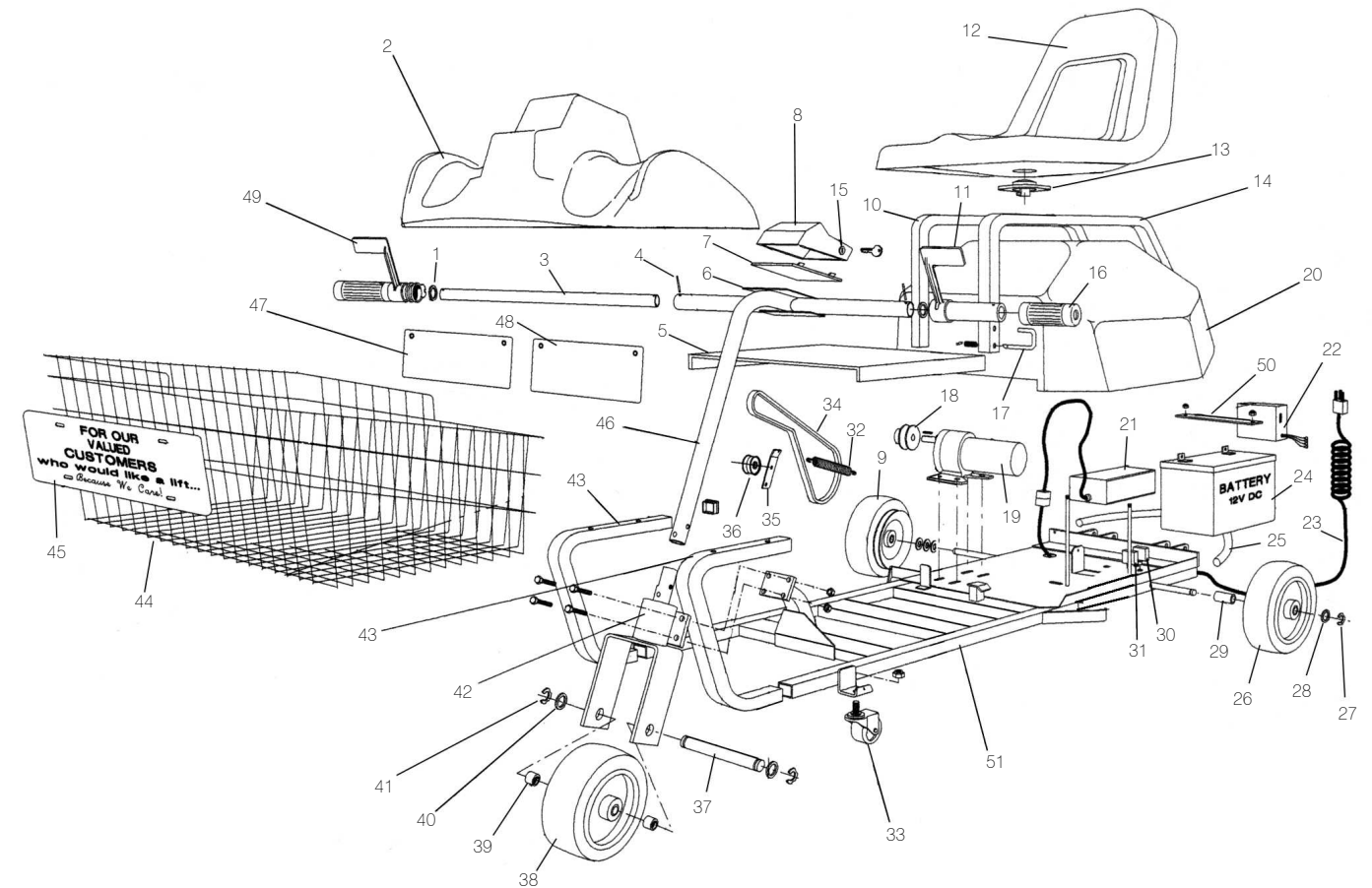

Item	Part #	Description	Item	Part #	Description	Item	Part #	Description
1	000-1235	Nylon Washer	18	200-1104	Drive Pulley	35	200-1547	Idler Mount Bar
2	280-1028	Front Cover	19	200-1091	Drive Motor	38	200-1106	Idler Pulley
3	200-1192	Inner Throttle Tube	20	280-1028	Rear Cover	37	280-1020	Front Axle Shaft
4	000-1404	Roll Pin	21	200-1819	Battery Charger	38	280-1022	Wheel Assembly
5	280-1027	Floor Plate	22	200-3208	"Pwm" Controller	39	000-1070	Spacer
6	200-1428	Base Mount Plate	23	280-1180	Charger Cord	40	000-1211	Washer, Nylon, 5/8"
7	200-1228	Bottom Plate	24	200-1006	Battery, Gel Cell	41	000-1075	"E" Retainer, 5/8"
8	280-1135	Control Box Cover	25	280-1072	Bumper Tube	42	280-1087	Steering Fork Structure
9	280-1122	Rear Drive Wheel Assembly	28	280-1124	Wheel Assembly	43	280-1148	Basket Mount Tube
10	280-1009	Seat Mount Tube, Rh	27	000-1075	"E" Ring Retainer, 5/8"	44	200-1151	Front Shopping Basket
11	200-1409	Throttle, Lh	28	000-1071	Flatwasher, 5/8"	45	200-1115	Plate, "Valued Customers"
12	200-1551	Basic Seat Assembly	29	000-1248	Spacer	46	280-1024	Steering Column
13	200-1553	Seat Switch	30	200-1021	Circuit Breaker, 25a	47	280-1037	Operating Instruction Plate
14	280-1010	Seat Mount Tube, Lh	31	200-1024	Circuit Breaker, 5a	48	280-1038	Warning Plate
15	200-1840	Key Switch	32	200-1549	Idler Spring	49	200-1408	Throttle Grip, Rh
16	000-1338	Grip, Red Vinyl	33	200-1052	Caster, Anti-Tip	50	280-1187	Battery Strap
17	280-1049	Seat Latch Rod	34	280-1053	Drive Belt	51	200-1140	Main Frame

MARTMATE Labels

• Replace labels if **Damaged, Lost or Unreadable!**

MARTMATE

By **mart cart**® 1-800-548-3373, 501-636-5776, www.martcart.com

MARTMATE
800-548-3373

USE INDOORS ON LEVEL SURFACE ONLY.
DO NOT REMOVE FROM STORE.
200-1764



CHARGING INFORMATION
Charge once daily for minimum of 8 hours. Do not exceed 16 hours!
200-1677

For information about
Owning your own
PERSONAL SCOOTER
by Mart Cart®
Call 1-800-548-3373 / 501-636-5776
www.assembledproducts.com 200-332702

BATTERY CHARGER
120 VOLTS-INPUT-1.5 AMPS
RECOMMENDED CHARGE CYCLE
NOT TO EXCEED 16 HOURS
DISCONNECT
BEFORE OPERATING CART



DAILY MAINTENANCE CHECK LIST

For optimum Cart availability and performance, the following items should be checked daily:

- ELECTRIC CORD and/or REEL.** - Replace cord-reel if cord is worn or frayed, 3 pronged plug is broken or reel will not retract. Be sure Power-Outlet provides protection through an operating Ground Fault Circuit Interrupter (GFCI).
- SEAT & MOUNTING.** - Tighten if necessary. If cracks or rust occur, or if seat rocks loosely, replace at once. Lubricate swivel or tracks with vaseline as required. Make sure Seat Lock is in good working condition.
- SEAT SWITCH.** - If cart is equipped with a seat switch, test and replace if not working properly. Cart must stop when weight is removed from seat.
- THROTTLE.** - Test for smooth "start", acceleration, deceleration and "stop". Replace cable or grip if necessary. Charge or replace battery if needed.
- ANTI-TIP CASTERS.** - Replace if broken. Maintain height adjustment of 3/8" to 1/2" above floor level.
- GENERAL.** - Repair or replace any component that would cause a potential "Safety Hazard".
- APPEARANCE.** - Wipe off and clean as needed for customer satisfaction and for store's "Public Image".

FOR PARTS OR SERVICE CALL
800-548-3373 or 501-636-5776
200-1127-01

WARNING
FOR INDOOR USE ONLY
TO PREVENT PERSONAL INJURY FROM ELECTRICAL SHOCK - **DO NOT USE CHARGING CORD IF:**
1) THE ELECTRICAL OUTLET IS NOT PROTECTED BY A GROUND FAULT CIRCUIT INTERRUPTER (GFCI).
2) THE ELECTRICAL CORD OR PLUG IS DAMAGED OR WORN. REPLACE BEFORE USING WITH ONLY 3 WIRE CORD AND PLUG OF SAME TYPE.

OPERATING INSTRUCTIONS
PLEASE READ BEFORE OPERATING

- ADJUST AND LOCK SEAT (SOME CHAIRS DO NOT HAVE A SEAT LOCK). SEE "WARNING". USE EXTRA CAUTION.
- IF CART HAS A KEY SWITCH, TURN POWER ON BY ROTATING KEY. (SOME CARTS TURN ON AUTOMATICALLY WITH THE OCCUPANT SEATED).
- SELECT FORWARD OR REVERSE.
- TWIST HAND-GRIP SLOWLY TO INCREASE SPEED - RELEASE TO STOP.
- TO STOP IN AN EMERGENCY: RELEASE HAND GRIP; OR TOUCH "OFF" BUTTON; OR TURN OFF KEY SWITCH IF APPLICABLE;
- STOP CART COMPLETELY BEFORE CHANGING DIRECTIONS. RETURN CART TO STARTING POINT WHEN DONE.
- LEAVE ALL SWITCHES IN THE "OFF" POSITION.
- EXIT WITH CARE. SEE "WARNING". ASK FOR HELP IF NEEDED.

290-1037-02

MM

WARNING
PLEASE READ TO AVOID PERSONAL INJURY

- USE AT YOUR OWN RISK. READ OPERATING INSTRUCTIONS. IF YOU ARE NOT FAMILIAR WITH THIS CART ASK FOR ASSISTANCE BEFORE USING.
- BE SURE CHARGER CORD IS UNPLUGGED BEFORE USING.
- SHUT POWER "OFF" AND USE EXTRA CAUTION BEFORE ENTERING OR EXITING SEAT.
- YOU MUST BE SEATED TO OPERATE CART. KEEP FEET AND LEGS INBOARD WHILE OPERATING.
- TO AVOID TIPPING, STAND ONLY IN CENTER OF CART. DO NOT LEAN ON OR OVER SIDE OF CART. SHUT POWER "OFF" & SET PARKING BRAKE WHEN STANDING.
- USE INDOORS ON LEVEL SURFACE ONLY.
- NO CHILDREN IN BASKET.

MM

THROTTLE GRIP ASSEMBLY

For the Mart Cart, MARTMATE and Mart Shopper

FIGURE 2

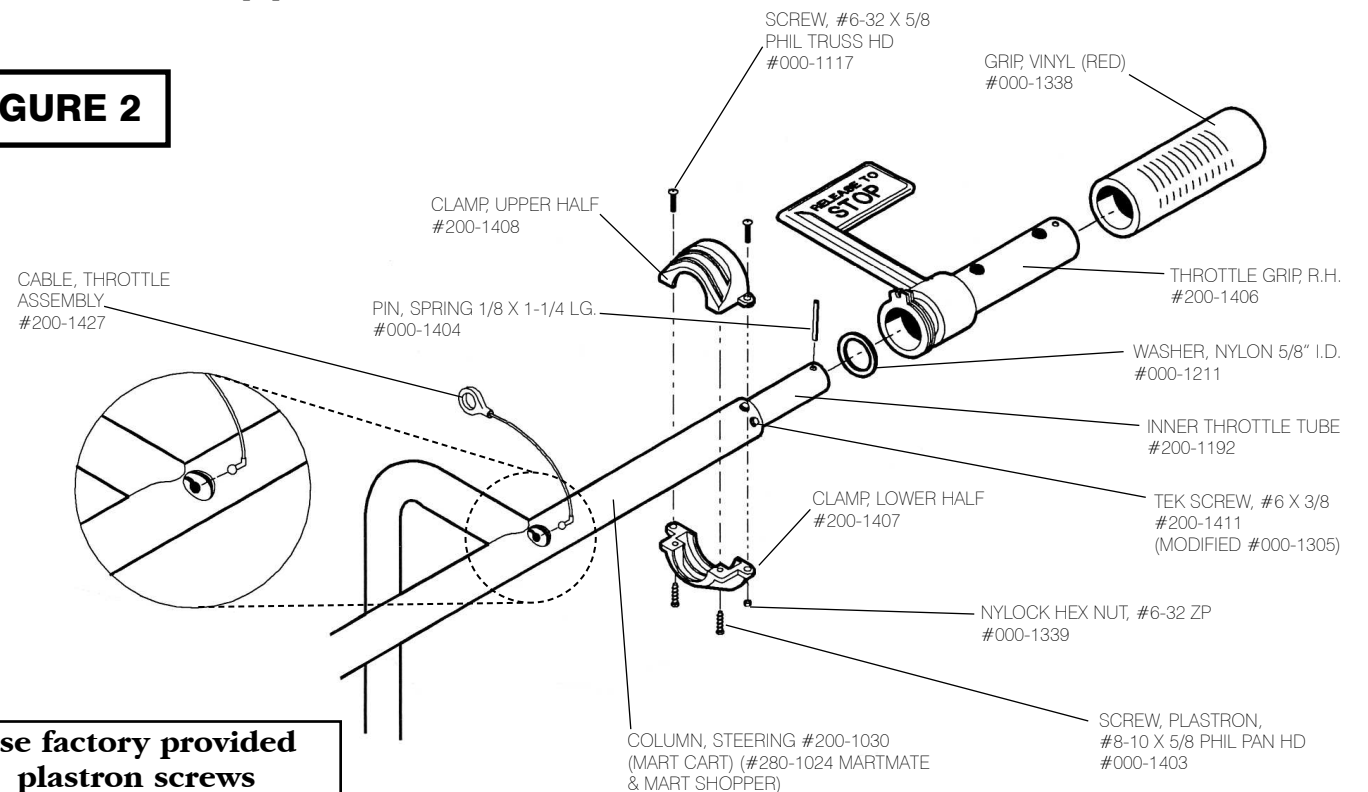

Use factory provided **plastron screws**

CORD REEL (MART CART)

- The cord reel is provided as a convenient tool for recharging your cart on a regular basis. When not in use, the cord is safely tucked away out of sight.
- The cord reel will give you years of trouble-free service providing the simple operating instructions posted on the cart are followed. (See "Recommended Operating Procedures").
- Cord reel failures are due mostly to abuse. Two common abuses are: tugging on cord to pull plug from outlet, and not allowing reel to retract the cord. Inspect daily the condition of cord, plug and reel. Replace if necessary.

IMPORTANT: A Ground Fault Circuit Interrupter (GFCI) should be used in your stores electrical outlet where you intend to draw current to charge your cart.

VARIABLE SPEED CONTROL

- The cart's speed is regulated by a potentiometer. This provides extremely smooth acceleration from 0 to 1.9 MPH, and is located in the control box on the steering column.

MOTOR MAINTENANCE

- There is no scheduled maintenance required. However, when the rear cover of the cart is removed for other reasons (Such as battery replacement) the motor should be examined.
- What to look for: Check the belt tension, check for any motor shaft seal leakage, check the motor mounts, check the brushes at least once every 5 years.
- Motor brushes-there are two brushes at the rear end of the motor. They are each located inside a small round plastic housing. A small screwdriver may be used to back out each brush. If the motor stops running, check the brushes.

FOOT BRAKE (MART CART)

- The Foot Brake should be tried daily for proper operation. Repair or replace any damaged or worn parts.

DRIVE BELT

- Check for belt alignment between drive and wheel pulleys. Belt should run true with no side misalignment and should also be centered over tension idler pulley.
- The belt tension idler provides automatic belt tensioning; however, it must be initially set so that the belt has a deflection of 1/2" to 3/4".
- To increase idler tension, re-hook spring into the next further chain link.

CIRCUIT BREAKER

- The circuit breaker is designed to protect your electrical system from transient overloads or electrical shorts. Either could cause serious damage without a circuit breaker to open the circuit.
- The circuit breakers are a manual reset type, and are rated at 5 and 25 amps. Each requires manual resetting once it has been tripped. They are located underneath the seat on the right hand side of the Mart Cart. On the MARTMATE and Mart Shopper they are found underneath the left rear corner and can be reached by hand from outside the cart.

CHARGING

- **HOW IT WORKS:** When the power supply cord is plugged into the stores electrical outlet the battery charger is energized. The charger sends approximately 14.5 volts to battery for charging. A third wire (Yellow) from the charger output inhibits the PWM until the power to the charger is disconnected. The motor circuit is interrupted until charging is complete.
- **CHARGING:** The cart will not move under power when the battery is being charged. If the cart moves while plugged in, check the power to your outlet before calling for service.

CONTROL BOX

- The master control box for the Mart Cart and MARTMATE is located on top of the steering column. It contains the "Forward, Neutral, Reverse" switch pad, battery condition indicator, horn and key switch (key switch optional).
- The cover can be removed by removing the four side screws. The control circuit board can be replaced if necessary.
- The master control for the Mart Shopper is also located on top of the steering column. It contains the "Forward, Neutral, Reverse" rocker switch, battery condition indicator, horn and key switch.

MARTMATE WIRING DIAGRAM

FIGURE 6

MM-01001 PICTORIAL WIRING DIAGRAM

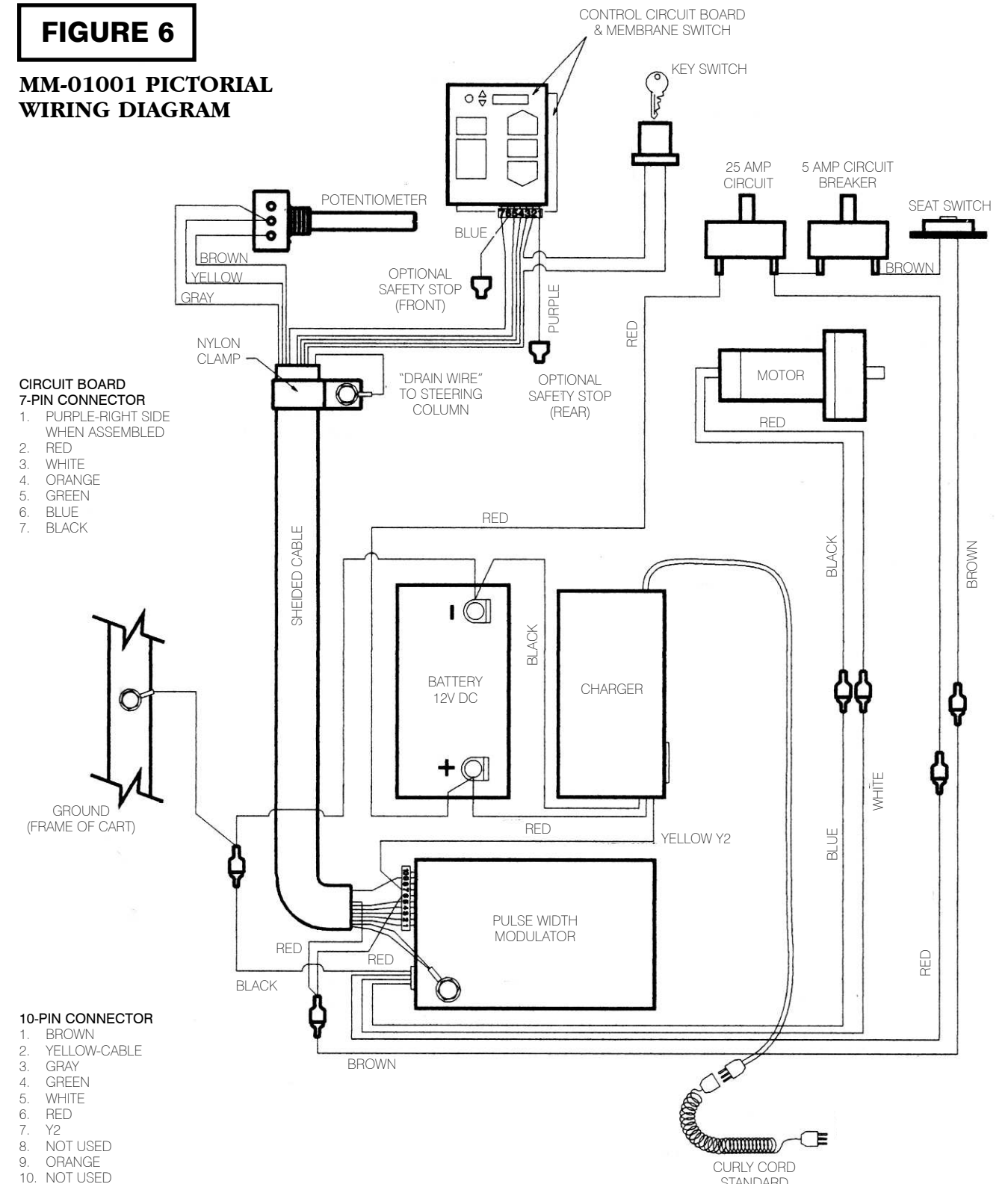

Note: If your cart is equipped with the DAAS System, please contact the service department at (800) 548-3373 or (479) 636-5776 for DAAS equipment pictorial diagram.

MARTMATE EXPLODED VIEW

FIGURE 5

280-3312-01 ECN 076

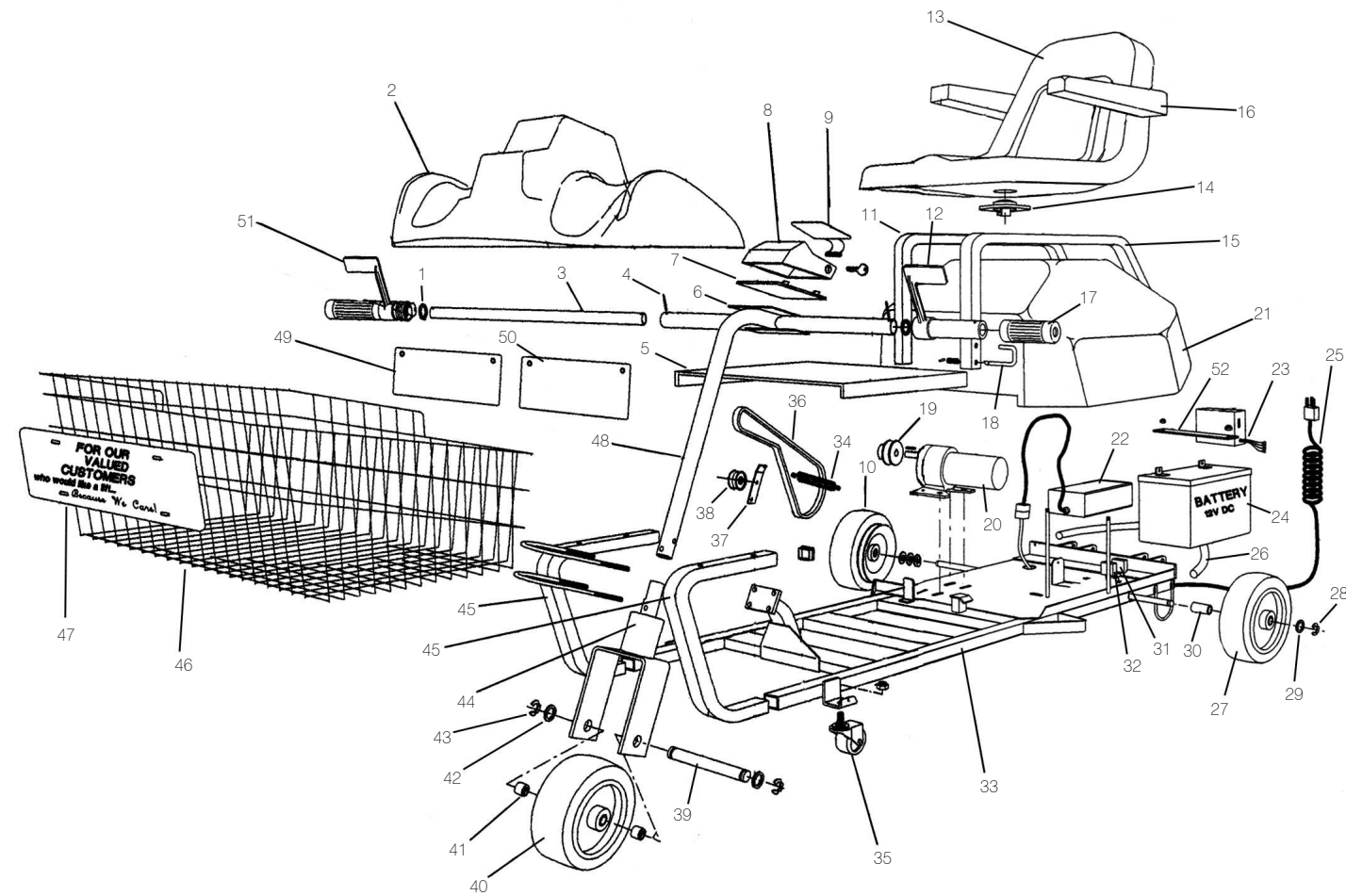

Item	Part #	Description
1	200-1235	Nylon Washer
2	280-1028	Front Cover
3	200-1192	Inner Throttle Tube
4	000-1404	Roll Pin
5	280-1027	Floor Plate
6	200-1428	Base Mount Plate
7	200-1228	Bottom Plate
8	200-1038	Control Box Cover
9	200-3300	Membrane Switch
10	280-1023	Rear Drive Wheel Assembly
11	280-1008	Seat Mount Tube, Rh
12	200-1408	Throttle Grip, Lh
13	200-1551	Basic Sea T
14	200-1553	Seat Switch
15	280-1010	Seat Mount Tube, Lh
16	200-1280	Arm Rest
17	000-1338	Grip, Red Vinyl
18	280-1048	Seat Latch Rod

Item	Part #	Description
19	200-1104	Drive Pulley
20	200-1091	Drive Motor
21	280-1028	Rear Cover
22	200-1818	Battery Charger
23	200-3208	"Pwm" Controller
24	200-1008	Battery, Gel Cell
25	280-1078	Cord, Power
26	280-1072	Bumper Tube
27	280-1022	Wheel Assembly
28	000-1075	"E" Ring Retainer, 5/8"
29	000-1071	Flat Washer, 5/8"
30	000-1248	Spacer
31	200-1021	Circuit Breaker, 25a
32	200-1024	Circuit Breaker, 5a
33	280-1140	Main Frame
34	200-1548	Idle Spring
35	200-1052	Caster, Anti-Tip
36	280-1063	Drive Belt

Item	Part #	Description
37	200-1647	Idle Mount Bar
38	200-1841	Idle Pulley
39	280-1020	Front Axle Shaft
40	280-1022	Wheel Assembly
41	000-1070	Spacer
42	000-1211	Washer, Nylon, 5/8"
43	000-1075	"E" Retainer, 5/8"
44	280-1097	Steering Fork Structure
45	280-1148	Basket Mount Tube
46	200-1161	Front Shopping Basket
47	200-1155	Plate, "Valued Customers"
48	280-1024	Steering Column
49	280-1037	Operating Instruction Plate
50	280-1038	Warning Plate
51	200-1406	Throttle Grip, Rh
52	280-1157	Battery Strap

MART CART EXPLODED VIEW

FIGURE 3

200-2020-02 ECN 075

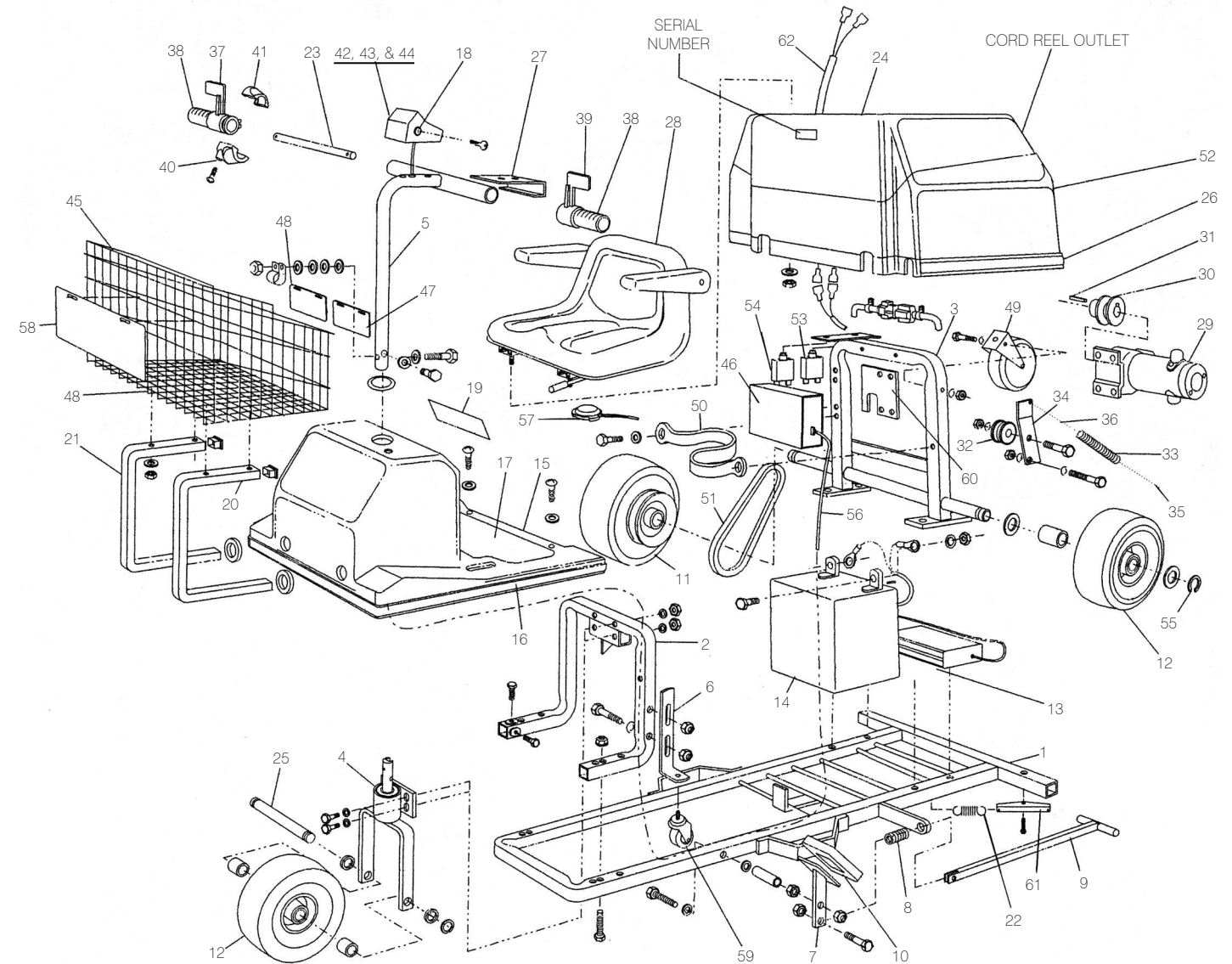

Item	Part #	Description
1	200-1000	Frame Structure, Chassis
2	200-1001	Frame Structure, Steering Support
3	200-1003	Frame Structure, Seat Support
4	200-1754	Steering Fork Assembly
5	200-1030	Column, Steering
6	200-1053	Bracket, Anti-Tip
7	200-1109	Brake Pedal
8	200-1087	Spring, Brake Arm
9	200-1086	Brake Arm Structure
10	200-1108	Pad, Brake
11	200-1431	Drive Wheel W/16" Pulley
12	200-1430	Wheel & Tire, Front & Left Rear
13	200-1004	Battery Charger W/38"Cord
14	200-1006	Battery, Gel Cell, 55 Amp
15	200-1253	Front Cover Assembly
16	200-8015	Trim (Front Cover)
17	200-1326	Floormat, Flex Trace
18	200-1640	Key Switch
20	200-1166	Basket Support Tube, Lh
21	200-1167	Basket Support Tube, Rh

Item	Part #	Description
22	000-1095	Spring, Lock Bar Retainer
23	200-1192	Inner Throttle Tube
24	200-8060	Rear Cover Assembly
25	200-1755	Front Axle
26	200-8025	Trim, Rear Cover
27	200-1429	Control Box Mount Plate
28	200-1722	Seat Assembly
29	200-1091	Electric Motor, 12 V dc
30	200-1105	Drive Pulley, 2" Dia.
31	000-1107	Key, Motor Shaft
32	200-1641	Idle Pulley
33	200-1548	Idle Spring
34	200-1547	Idle Arm
35	000-1423	Idle Chain, 4 Link
36	000-1424	Idle Chain, 7 Link
37	200-1406	Throttle Grip, Right
38	000-1338	Hand Grip, Red Vinyl
39	200-1409	Throttle Grip, Left
40	200-1407	Throttle Clamp Half, Lower
41	200-1408	Throttle Clamp Half, Upper

Item	Part #	Description
42-44		See page 6
45	200-1802	Basket, Front, Shopping
46	200-3208	Pwm Motor Controller
47	200-1387	Operating Instruction Plate
48	200-1386	Warning Plate
49	200-1393	Cord Reel
50	200-1027	Battery Strap
51	200-1303	Drive V-Belt
52	200-1063	Scuff Guard
53	200-1021	Circuit Breaker, 25 Amp
54	200-1024	Circuit Breaker, 5 Amp
55	000-1075	"E" Clip
56	200-3225	Wiring Cable, 10 Wire
57	200-1553	Seat Switch, Twistlock
58	200-1155	Valued Customer Plate
59	200-1052	Caster, Anti-Tip
60	200-1556	Motor Mount Plate
61	200-1206	Locking Bar (Rear Cover)
62	200-1559	Wiring, Seat Switch

MART CART WIRING DIAGRAM

FIGURE 4

MC-02002 PICTORIAL WIRING DIAGRAM

- CIRCUIT BOARD 7-PIN CONNECTOR**
1. PURPLE-RIGHT SIDE WHEN ASSEMBLED RED
 2. WHITE
 3. ORANGE
 4. GREEN
 5. BLUE
 6. BLACK

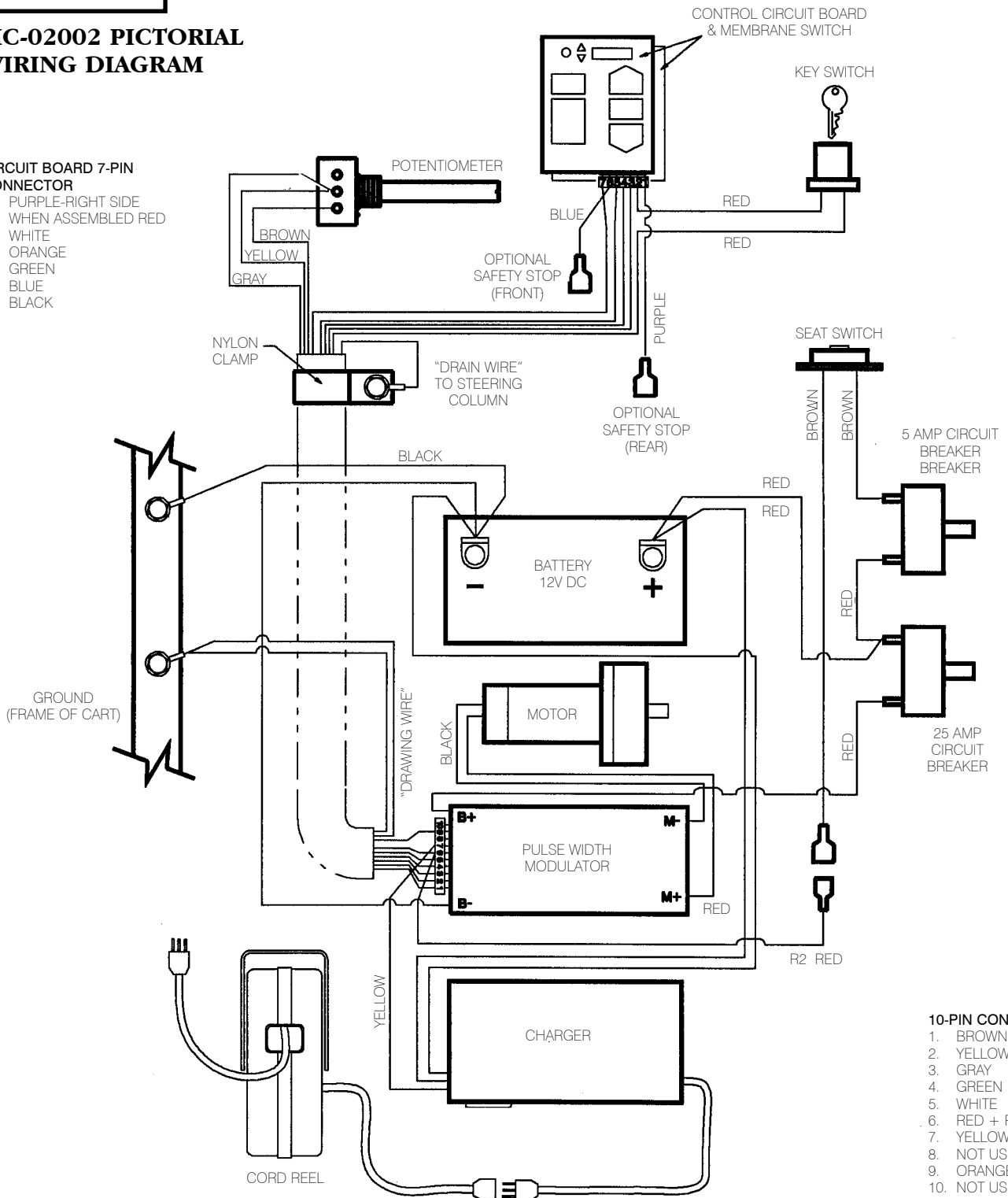

- 10-PIN CONNECTOR**
1. BROWN
 2. YELLOW-CABLE
 3. GRAY
 4. GREEN
 5. WHITE
 6. RED + R2
 7. YELLOW
 8. NOT USED
 9. ORANGE
 10. NOT USED

Note: If your cart is equipped with the DAAS System, please contact the service department at (800) 548-3373 or (479) 636-5776 for DAAS equipment pictorial diagram.

MART CART LABELS

• Replace labels if **Damaged, Lost or Unreadable!**

1-800-548-3373 OR 1-501-636-5776

USE INDOORS ON LEVEL SURFACE ONLY.
DO NOT REMOVE FROM STORE.
200-1764

WARNING: FAILURE TO COMPLY WITH POSTED OPERATING INSTRUCTIONS AND LOAD LIMITATIONS COULD RESULT IN ACCIDENT OR INJURY.

LOAD LIMITATIONS

MAXIMUM PERSONS1
MAXIMUM WEIGHT (Person)550 LBS.
MAXIMUM LOAD (Basket)150 LBS.

NO CHILDREN ALLOWED IN BASKET
MART CART



CAUTION
HIGH VOLTAGE
Disconnect power before servicing



For information about **Owning your own PERSONAL SCOOTER** by Mart Cart*
Call 1-800-548-3373 / 501-636-5776
www.assembledproducts.com 200-3327-02

READ BEFORE OPERATING: OPERATING INSTRUCTIONS

1. Turn on power with key.
2. Select "Forward" or "Reverse".
3. Twist grip SLOWLY, release to STOP.
4. Return Cart.
5. Leave all switches in "OFF" position.
6. DO NOT REMOVE FROM STORE.

Use indoors on level surface only!
200-1593-01

WARNING
FOR INDOOR USE ONLY
TO PREVENT PERSONAL INJURY FROM ELECTRICAL SHOCK DO NOT USE CHARGING CORD IF:

- 1) THE ELECTRICAL OUTLET IS NOT PROTECTED BY A GROUND FAULT CIRCUIT INTERRUPTER (GFCI)
- 2) THE ELECTRICAL CORD OR PLUG IS DAMAGED OR WORN. REPLACE BEFORE USING WITH ONLY 3 WIRE CORD AND PLUG OF SAME TYPE.

OPERATING INSTRUCTIONS
Automatic Rewind Cord Reel
TO REWIND: PULL OUT ON CORD UNTIL LOCKING DEVICE STOPS "CLICKING" SOUND. ALLOW CORD TO RETRACT UNDER TENSION
CAUTION: DO NOT PUSH CORD INTO HOLE OR DAMAGE COULD RESULT.
200-1752-03

6 AMP BATTERY CHARGER
120 VOLTS-INPUT-1.2 AMPS OR 220 VOLTS - 7 AMPS
DISCONNECT BEFORE OPERATING CART
RECOMMENDED CHARGE CYCLE: DO NOT EXCEED 16 HOURS

DAILY MAINTENANCE CHECK LIST

For optimum Cart availability and performance, the following items should be checked daily:

1. **ELECTRIC CORD and/or REEL** - Replace cord-reel if cord is worn or frayed, 3 pronged plug is broken or reel will not retract. Be sure Power-Outlet provides protection through an operating Ground Fault Circuit Interrupter (GFCI)
2. **SEAT & MOUNTING** - Tighten if necessary. If cracks or rust occur, or if seat rocks loosely, replace at once. Lubricate swivel or tracks with vaseline as required. Make sure Seat Lock is in good working condition.
3. **SEAT SWITCH** - If cart is equipped with a seat switch, test and replace if not working properly. Cart must stop when weight is removed from seat.
4. **THROTTLE** - Test for smooth "start", acceleration, deceleration and "stop". Replace cable or grip if necessary. Charge or replace battery if needed.
5. **ANTI-TIP CASTERS** - Replace if broken. Maintain height adjustment of 3/8" to 1/2" above floor level.
6. **GENERAL** - Repair or replace any component that would cause a potential "Safety Hazard".
7. **APPEARANCE** - Wipe off and clean as needed for customer satisfaction and for store's "Public Image".

FOR PARTS OR SERVICE CALL
800-548-3373 or 501-636-5776
200-1127-01

OPERATING INSTRUCTIONS
PLEASE READ BEFORE OPERATING

1. ADJUST AND LOCK SEAT (SOME CHAIRS DO NOT HAVE A SEAT LOCK). SEE "WARNING". USE EXTRA CAUTION.
2. IF CART HAS A KEY SWITCH, TURN POWER ON BY ROTATING KEY. (SOME CARTS TURN ON AUTOMATICALLY WITH THE OCCUPANT SEATED.)
3. SELECT "FWD" OR "REV" (FORWARD OR REVERSE).
4. TWIST HAND-GRIP SLOWLY TO INCREASE SPEED -- RELEASE TO STOP.
5. TO STOP IN AN EMERGENCY: RELEASE HAND GRIP; OR TOUCH "OFF" BUTTON; OR TURN OFF KEY SWITCH IF APPLICABLE; APPLY LEFT FOOT BRAKE.
6. STOP CART COMPLETELY BEFORE CHANGING DIRECTIONS.
7. RETURN CART TO STARTING POINT WHEN DONE.
8. LEAVE ALL SWITCHES IN THE "OFF" POSITION.
9. EXIT WITH CARE. SEE "WARNING". ASK FOR HELP IF NEEDED.

200-1386-02 MC

WARNING
PLEASE READ TO AVOID PERSONAL INJURY

1. USE AT YOUR OWN RISK. READ OPERATING INSTRUCTIONS. IF YOU ARE NOT FAMILIAR WITH THIS CART ASK FOR ASSISTANCE BEFORE USING.
2. CART IS ON WHEELS AND MAY ROLL. SEAT MAY SWIVEL OR SLIDE.
3. USE EXTRA CAUTION GETTING ON OR OFF CART. DO NOT USE UNTIL CHAIR LOCKS SECURELY. SEEK ASSISTANCE IF NECESSARY.
4. YOU MUST BE SEATED TO OPERATE CART. KEEP FEET AND LEGS INBOARD WHILE OPERATING.
5. IF CART HAS A KEY SWITCH, TURN POWER OFF BEFORE ENTERING OR EXITING THE SEAT. USE CAUTION!
6. TO AVOID TIPPING STAND ONLY IN CENTER OF CART. DO NOT LEAN ON OR OVER SIDE OF CART. SHUT POWER "OFF" WHEN STANDING.
7. USE INDOORS ON LEVEL SURFACE ONLY.
8. BE SURE CHARGER CORD IS UNPLUGGED BEFORE USING.
9. NO CHILDREN IN BASKET.

200-1387-02 MC

Note: All labels on this page are not to scale.