

**IMPORTANT DOCUMENT - DELIVER TO MANAGER**



# OWNER'S MANUAL and TECHNICAL DOCUMENTATION

**Model 280-5563**



**Mart Cart® is a quality product line of Assembled Products® Corporation**

115 E. Linden • Rogers, Arkansas 72756 USA  
(479) 636-5776 • (479) 636-3245 fax  
**1-800-548-3373** [www.martcart.com](http://www.martcart.com)

**E**



## — IMPORTANT INFORMATION —

Please read before operating.

### CONGRATULATIONS!

You have just purchased the best electric shopping cart on the market today. This Mart Cart incorporates the very latest in technological advances. To assure you of the best and safest performance as well as longest life, please read the enclosed information. After reading this manual, should you have a service problem or need help, please call our Customer Service Department with the serial number of your cart, at our toll free number: **1-800-548-3373 or (479) 636-5776**.

**DAMAGE:** Check the shipping carton for any visible damage. Report the damage to the freight carrier immediately. File a claim with the carrier if actual damage to your cart has occurred. Check the contents of the carton. The contents should agree with the information listed on the packing list. Report any discrepancy to the carrier and the factory immediately.

**TO ORDER PARTS:** Call **1-800-548-3373 or (479) 636-5776**. Be sure to give the serial number to the Service Department personnel. The Mart Cart serial number is located on the seat support tube under the seat as shown in parts list portion of this manual.

**TERMS:** All parts will be shipped with approved credit card, check in advance or C.O.D. Commercial accounts are allowed 15 day terms from date on invoice with approved credit.

**FREIGHT:** All freight will be paid by the customer. Special consideration will be given to items under warranty coverage.

**ATTENTION:** It is the responsibility of the owner of this cart to maintain the cart in a safe and reliable operating condition at all times.

**NOTE:** Specifications found in this manual subject to change without notice.

## — IMPORTANT SAFETY INSTRUCTIONS —

Please read before operating.

### WARNINGS

- Never attempt to charge the battery in this cart without using an electrical outlet that is protected by a GFCI.
- Replace charging cord if plug is damaged or if the cord is worn or frayed. Never use the charging cord without proper grounding. Do not use if plug does not have three prongs.
- Never allow the cart to be used out-of-doors or on any surface that is not level.
- Always disconnect power before servicing.
- See "Daily Maintenance Checklist," and follow instructions.
- Cart can roll. Enter and exit cart with care.

### OPERATING PROCEDURES

- New carts will need charging! Charge batteries for 24 hours prior to first use.
- **THIS CART IS FOR USE INDOORS ON A FLAT, LEVEL SURFACE ONLY.**
- **DO NOT STAND ON CAROT.** (See "Operating & Warning Instructions" on cart).
- After battery is charged, disconnect power supply cord BEFORE operating cart.
- **DO NOT** exceed the load limitations as shown on the cart.
- Return power cord to circular cavity when not charging
- **DO NOT** allow children to operate or play on cart. Keep cart secured with key (if applicable), at service counter.

### DAILY MAINTENANCE CHECK LIST

For optimum cart availability and performance, the following items should be checked daily:

- **ELECTRIC CORD**—Replace cord if cord is worn or frayed, 3-pronged plug is broken or reel (optional) will not retract. Be sure power outlet provides protection through an operating "Ground Fault Circuit Interrupter" (GFCI).
- **SEAT AND MOUNTING**—Tighten if necessary. If cracks or rust occur, or if seat rocks loosely, replace at once.
- **SEAT SWITCH**—Test and replace if not working properly. Cart must stop when weight is removed from seat.
- **THROTTLE**—Test for smooth "start, acceleration, deceleration, and stop." Repair if necessary. Charge or replace battery if needed.
- **ANTI-TIP CASTERS**—Replace if broken. Maintain height adjustment of 1/8" to 1/2" above floor level.
- **GENERAL**—Repair or replace any component that may cause a potential safety hazard.
- **APPEARANCE**—Wipe off and clean as needed for customer satisfaction and for store's public image.

## — BATTERY CHARGING INSTRUCTIONS —

Please read before charging.

Your cart is equipped with the *Intelli-Charge™* system. While operating the cart, the LED will be solid **green** until the battery falls below 12.4 volts and then turns solid **amber**. When the battery charge falls below 10.5 volts, the LED will begin flashing **red**. The person riding the cart should have ample time to return the cart for charging. When the rider exits the cart, the horn will start beeping in unison with the **red** flashing LED. This will alert those responsible for maintaining the cart to plug in the charger. When plugged into a 120v AC wall socket, the LED will flash **amber** and the horn will silence. When charging is complete the LED will start flashing **green**. The charger may be left plugged in even longer as it will NOT harm the battery.

### LED Color Status

#### LED Off

**Green** (solid)

**Amber** (solid)

**Red** - Flashing

### Description while operating

Off/On rocker switch is set to "Off" position

Off/On rocker switch is set to "On" position - seat switch is engaged - battery is fully charged

Off/On rocker switch is set to "On" position - seat switch is engaged - battery is below 12.4 volts

Battery needs to be charged - below 10.5 volts

### LED Color Status

**Amber** - Flashing

**Green** - Flashing

### Description while charging

Charger is plugged in and battery is being charged

Charger is plugged in and battery is charged

- Install a Ground Fault Circuit Interrupter (GFCI) in the electrical circuit wherever the cart is to be charged. This is to protect against any possible shock hazard.
- AC voltage required is 100-240 VAC (50/60 Hz). The current draw is 3.5 amps maximum.
- Charge battery every night, all night, and at every opportunity. When the battery is fully charged, the charger will maintain a "float voltage" which will not damage the battery.
- Do not allow the battery to fully discharge by skipping the nightly charging cycle. A fully discharged battery will take 7 hours to fully charge, so it is best not to let the battery become completely discharged.
- Do not store the cart with a discharged battery. This can cause premature battery failure. Fully charge the battery at least every 30 days if in a low usage location.
- No maintenance of battery is required. The AGM battery is maintenance free and water cannot be added.

**NOTE:** Under normal conditions, the battery will last more than 2 years or longer if the above recommendations are followed. Replace with original Mart Cart battery only. Mart Cart is not responsible for any adverse effects caused by replacement with any other type of battery.

**IMPORTANT:** Your cart has been equipped with an AGM (Suspended Electrolyte) Battery during the manufacturing process as original equipment.

The manufacturer recommends that you replace the original battery only with the same type and rating to prevent damage to your cart's internal components, charging system, or personal injury to you and your customer.

## — BATTERY REPLACEMENT INSTRUCTIONS —

Please read before replacing battery.

**Be Responsible!** Recycle old battery or dispose of according to local or national codes. See next column, under **DISPOSAL**.

To Replace Battery: (Read precautions on batteries, under Charging Instructions and Safety Precautions, to avoid any sparks)

1. Turn off key switch (if equipped, or flip On/Off switch to "Off" position). Disconnect charger cord from wall outlet, if plugged in.
2. Reach under right rear of back cover and pull latch, then tilt chair forward.
3. Remove rear cover.
4. Untie battery cover strap and remove battery cover.

**CAUTION: Do not cross battery posts with metal object!**

5. Remove old battery and place new battery.
6. Reinstall battery cover. It will only fit one way.
7. Secure battery cover strap.
8. Before reinstalling cover, check wheel condition, and general condition of the chair.
9. Reinstall rear cover and tilt chair back.
10. Test cart for proper operation. Charge battery if necessary.

## — ADDITIONAL INFORMATION —

### SEAT LOCK

For XT12 with sliding seat. The seat lock and the chair should be inspected daily for proper function. The release/locking arm should move freely and spring back into locking position. If return spring is broken, **DO NOT USE** cart until spring is replaced.

### SEAT SWITCH

The seat switch is located under seat. Pressure (weight) on the seat closes the control circuit, and allows the cart to operate.

### VARIABLE SPEED CONTROL

The cart's speed is regulated by a potentiometer. This provides extremely smooth acceleration from 0 to 2.2 MPH, and is located in the control box on the steering column.

### CIRCUIT BREAKER

The circuit breaker is designed to protect your electrical system from transient overloads or electrical shorts. Either could cause serious damage without a circuit breaker to open the circuit. The circuit breaker is a manual reset type. It requires manual resetting once it has been tripped. It is located on the battery cover.

### CHARGING

**HOW IT WORKS:** When the power supply cord is plugged into the store's electrical outlet the battery charger is energized. The charger sends approximately 14.5 volts to the battery for charging. A third wire (yellow) from the charger output inhibits the PWM until the power to the charger is disconnected. The motor circuit is interrupted until charging is complete.

**NOTE:** The cart will not move under power when the battery is being charged. If the cart moves while plugged in, check the power to your outlet before calling for service.

### CONTROL BOX

The master control box is located on top of the steering column. It contains the RUN/STOP/HORN switch, and key switch (optional keyless system available). The cover can be removed by removing the four bottom screws. Our models are equipped with the **Intelli-Charge™** system, a bicolor LED can be found in the **RUN/STOP/HORN** switch.

## — DISPOSAL —

Please read before disposing your old battery.

The Mart Cart model number 280-5563 is certified 100% by Recycle America, LLC., a subsidiary of Waste Management and those models are PVC free. Spent batteries must be treated as hazardous waste and disposed of in accordance with local, state and federal guidelines. The BATTERY ACT of 1996 applies to battery disposal and recycling. The life expectancy of the Mart Cart is 7-10 years. The life expectancy of the battery can be 2 years or longer with recommended charging procedures. The disposal of the Mart Cart can be administered by any local metal recycling center. The recycling of the battery can be administered by any local battery recycling center.

## — PARTS LISTS AND SCHEMATICS —

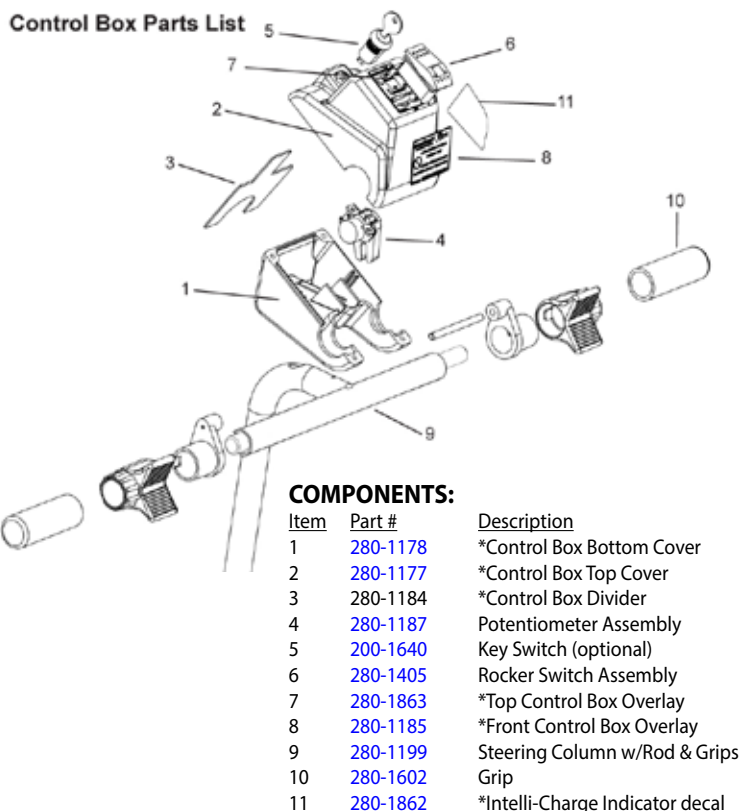

### COMPONENTS:

Item	Part #	Description
1	280-1178	*Control Box Bottom Cover
2	280-1177	*Control Box Top Cover
3	280-1184	*Control Box Divider
4	280-1187	Potentiometer Assembly
5	200-1640	Key Switch (optional)
6	280-1405	Rocker Switch Assembly
7	280-1863	*Top Control Box Overlay
8	280-1185	*Front Control Box Overlay
9	280-1199	Steering Column w/Rod & Grips
10	280-1602	Grip
11	280-1862	*Intelli-Charge Indicator decal

**\*NOTE: Parts are ordered in Control Box Kits below.**

### CONTROL BOX KITS:

Part #	Description
280-1228	Control Box, Keyless (1-4, 6-8)
280-1229	Control Box, Keyed (1-8)
280-1230	Control Box Top, Keyless (2, 4, 6-8)
280-1231	Control Box Top, Keyed (2, 4-8)
280-1232	Box Top with Decals (2, 7, 8)

— DECALS FOUND ON MART CART® ELECTRIC SHOPPING CART —

Please call 1-800-548-3373 if your decals are missing or are needing replacement.

Standard decals and signs are English and Spanish (see part numbers below). Call for other languages.

**DAILY MAINTENANCE CHECK LIST**  
 For optimum Cart availability and performance, the following items should be checked daily:  
 1. **ELECTRIC CORD AND/OR REEL** - Repaire cord and/or reel if cord is worn or frayed. If pronged plug is broken or reel will not rotate. Do your Power-Zucker provides protection through an operating Ground Fault Circuit Interrupter (GFCI).  
 2. **SEAT & MOUNTING** - Tighten if necessary. If empty or not minor, or if seat needs loosening, replace it once. Lubricate axles or tracks with vaseline as required. Make sure Seat Lock is in good working condition.  
 3. **SEAT SWITCH** - If cart is equipped with a seat switch, test and replace if not working properly.  
 4. **THROTTLE** - Test for smooth "start", acceleration, deceleration and "stop". Repair if necessary. Charge or replace.  
 5. **ANTI-TIP CASTERS** - Replace if broken. Maximum height adjustment of 1/8" to 1/2" above floor level.  
 6. **GENERAL** - Repair or replace any component that would cause a potential "Safety Hazard".  
 7. **APPEARANCE** - Wipe off and clean as needed for customer satisfaction and for store's "Public Image".

**LISTA DE MANTENIMIENTO DIARIO**  
 Para la disponibilidad óptima y el desempeño, del Carrito, los siguientes artículos deben chequearse diario:  
 1. **LA CUERDA Y EL CARROTE ELÉCTRICOS** - Reemplaza la cuerda-carrete si la cuerda está gastada o pelada, o si el carrote no gira libremente. Reemplaza la llave de freno si el cable de freno está dañado. Reemplaza la llave de freno si el cable de freno está dañado. Reemplaza la llave de freno si el cable de freno está dañado. Reemplaza la llave de freno si el cable de freno está dañado.  
 2. **EL ASIENTO Y LA MONTAJE** - Ajuste si es necesario. Si el asiento no funciona, pruébalo y reemplázalo si es necesario. Lubricar ejes o rieles con vaselina cuando sea necesario. Asegúrese que el Carrito de Aluminio está en buena condición para trabajar.  
 3. **COMANDADOR DEL ASIENTO** - Si el carrito está equipado con un controlador del asiento, compruebe y reemplácelo si no funciona apropiadamente. El carrito debe pararse cuando se quite peso del asiento.  
 4. **RESOROS** - Ajuste los resoros de los castores, la aceleración, la desaceleración y "parar". Repare si es necesario. Cargue o reemplazé la batería si es necesario.  
 5. **LAS RUEDAS Y LAS ANTI-TIP CASTERS** - Reemplazelas si están quebradas. Mantenga el ajuste de la altura de 1/8" a 1/2" encima del nivel del piso.  
 6. **GENERAL** - Repare o reemplazé cualquier componente que causará un "Riesgo de Seguridad" potencial.  
 7. **LA APARIENCIA** - Limpie y limpie cuando sea necesario para la satisfacción del cliente y para la "Imagen Pública" de la tienda.

FOR PARTS OR SERVICE CALL FRANK BAUTER OF SERVICE LINE  
 800-548-3373 or 479-636-5776 800-548-3373 or 479-636-5776 200-1127

200-1127

Maximum Weight, seat = 550 lbs., basket = 200 lbs.  
 peso máximo, asiento = 200kg, canasta = 90kg

Maximum Weight, seat = 550 lbs., basket = 200 lbs.  
 peso máximo, asiento = 200kg, canasta = 90kg

280-2194



**PATENTED**  
 U.S. PATENT NO. 7108090 B2

280-3007

280-3007

280-1663

**IN-STORE USE ONLY**  
 PARA USO DENTRO DE LA TIENDA SOLAMENTE

**FOR OUR VALUED CUSTOMERS...  
 BECAUSE WE CARE.**

PARA NUESTROS ESTIMADOS CLIENTES...  
 PORQUE USTED ES IMPORTANTE

**IN-STORE USE ONLY**  
 PARA USO DENTRO DE LA TIENDA SOLAMENTE

**NO CHILDREN IN BASKET!**  
 ¡NO NIÑOS EN LA CANASTA!

200-1155 (front & back)

**WARNING**  
 PLEASE READ TO AVOID PERSONAL INJURY  
 LEER SU PROPIOS RIESGOS DESTINADO PARA USO DENTRO DE LA TIENDA Y EN SUPERFICIES PLANAS

1. Read operating instructions or ask for assistance before using.
2. Use extra caution getting "ON" or "OFF" cart.
3. Cart is on wheels and may roll.
4. You must be seated to operate cart.
5. Keep feet and legs inboard while operating.
6. Do not stand on cart.
7. Do not lean "ON" or "OVER" the side of the cart.
8. NO CHILDREN IN BASKET.

**ADVERTENCIA**  
 FAVOR LEER PARA EVITAR ACCIDENTES.  
 LEER SU PROPIOS RIESGOS DESTINADO PARA USO DENTRO DE LA TIENDA Y EN SUPERFICIES PLANAS

1. Lea las instrucciones de operación o pida ayuda antes de usar.
2. Tenga mucha precaución al "SUBIR" y "BAJAR" del carrito.
3. No olvide que el carrito esta sobre ruedas.
4. Usted tiene que estar sentado para operar el carrito.
5. Mantenga los pies y piernas en el carrito cuando lo este usando.
6. Favor de no pararse en el carrito.
7. No se recargue "EN" ni "SOBRE" el costado del carrito.
8. No ponga niños en la canastilla.

**PULL LATCH UNDERNEATH TO REMOVE COVER**

280-1307

**IF CORD IS LOST OR DAMAGED PLEASE USE REPLACEMENT CORD UNDER COVER**

280-1831

200-1387

**OPERATING INSTRUCTIONS**  
 PLEASE READ BEFORE OPERATING

1. Turn key on and/or press the "Run" switch.
2. Thumb levers rotate to power the cart. Press top lever forward to go forward. Press bottom lever down to go in reverse.
3. To stop, release the thumb levers and/or press the "stop" switch.
4. If needed, ask cashier for assistance to get your items to your vehicle. Under no circumstances are carts to be taken outside the store.

**DO NOT REMOVE FROM STORE**

**INSTRUCCIONES DE OPERACION**  
 LEA ANTES DE USAR

1. Prenda la llave y/o apriete el interruptor de encendido.
2. Las palancas del pulgar giran para accionar el carrito. Apriete la palanca para avanzar hacia adelante. Presione la palanca inferior hacia abajo para conducir de reversa.
3. Para detenerse, suelte la palanca o presione el botón de "alto".
4. De ser necesario, pida ayuda a algun empleado de la tienda para llevar sus compras a su vehiculo. Bajo ninguna circunstancia deberá sacar el carrito fuera de la tienda.

**NO SAQUE ESTE CARRITO DE LA TIENDA**

280-1570

**CAUTION HIGH VOLTAGE**  
 Disconnect power before servicing

000-1183

**DO NOT REMOVE**

**Normal Operation**  
 Flashing (red light), Battery needs to be charged  
 Flashing (green light), Battery is being charged  
 Flashing (blue light), Charging is complete

**Trouble Shooting**  
 If cart is plugged in and DOES NOT light, do the following:  
 A) Check outlet for proper power.  
 B) Check circuit breaker on cart.  
 C) Replace onboard charger if A and B are satisfied.

**Replace Cart Battery if:**  
 A) Cart charges more than 24 hours and flashing light NEVER turns GREEN.  
 B) If light flashes RED within the first day of use.

**Operacion Normal**  
 Destellando (rojo), bateria necesita ser cargada  
 Destellando (verde), bateria ha sido cargada  
 Destellando (azul), carga completa

**Resolución de problemas**  
 Si el carrito está conectado a la luz y NO se está iluminando, haga lo siguiente:  
 A) Verifique el enchufe de pared para saber si hay la energía.  
 B) Verifique el interruptor de la tienda.  
 C) Reemplace el cargador que está en el carrito, si A y B funcionan.

**Reemplazé la batería del carrito si:**  
 A) El carrito está conectado por más de 24 horas y la luz intermitente nunca prende VERDE.  
 B) Si la luz ROJO, prende dentro del primer día de manejar el carrito.

280-1730 (front & back)

280-1185

**MART CART X12**  
 WWW.MARTCART.COM  
 800-548-3373 • 479-636-5776

**HANDLE GRIPS**  
 POWER THE CART  
 Turning up goes forward  
 Turning down is reverse

**USE INDOORS ON LEVEL SURFACE ONLY!**  
**DO NOT REMOVE FROM STORE!**

**STOP ALTO**

**FULL CHARGE** **HALF CHARGE** **LOW CHARGE IMMEDIATELY**

**DO NOT STAND ON BUMPER**

280-1863

**CHARGE EVERY NIGHT ALL NIGHT AND AT EVERY OPPORTUNITY**

280-1545

**Quick Change Battery Cover**  
 NO TOOLS NEEDED  
 LIFT HERE TO REMOVE

280-1783

**Warning**  
 FIRE HAZARD, USE ONLY 280-1214 MART CART BATTERY.  
 DO NOT MODIFY THE WIRING HARNESS OR THE BATTERY COVER.

280-1509

**DO NOT STAND ON BUMPER**

280-1862

**DO NOT STAND ON BUMPER**

280-2103

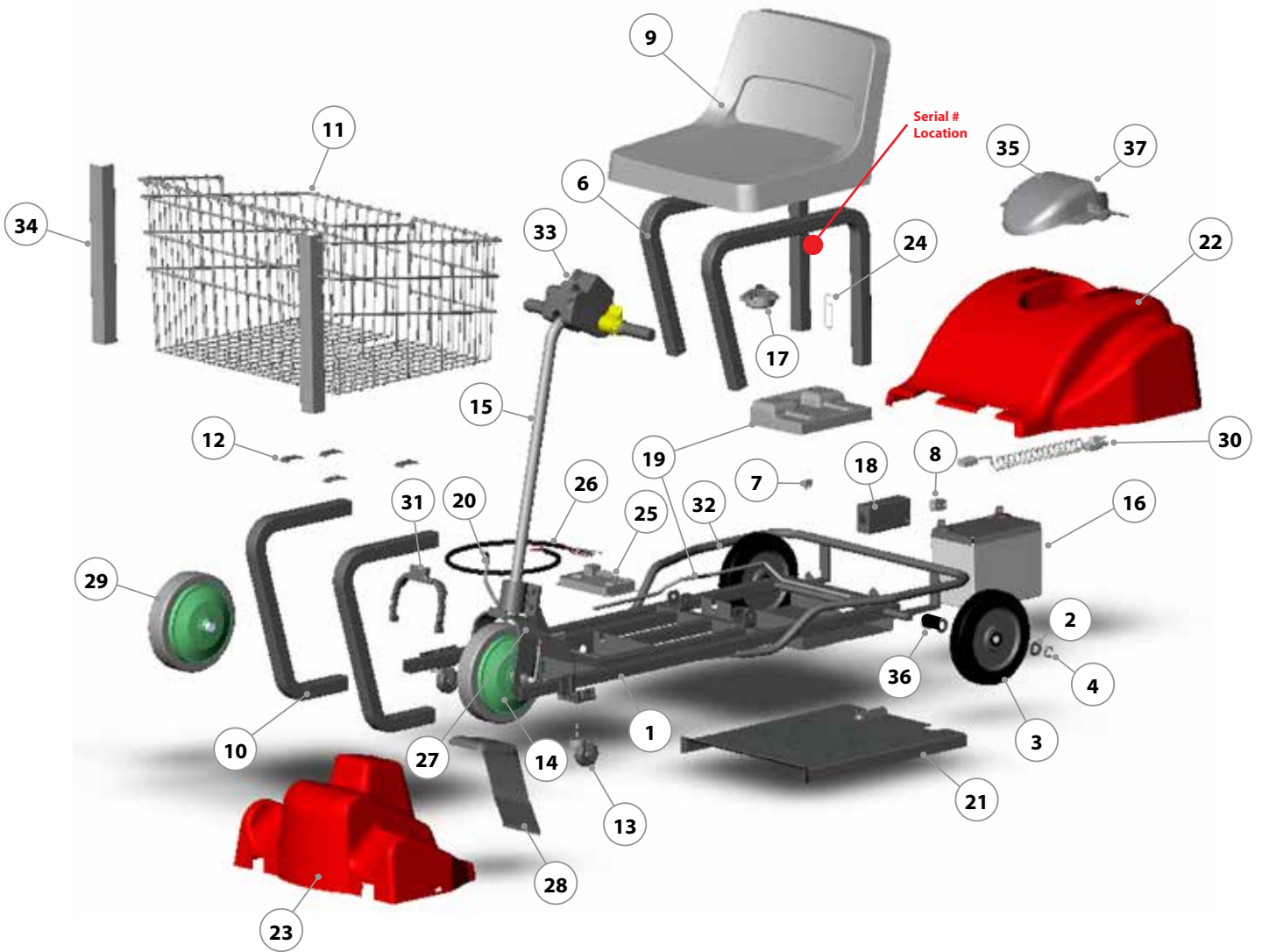

Item	Part No.	Description
1	<a href="#">280-1818</a>	Main Frame (280-1820 with bumper)
2	000-1224	5/8" Bushing (2 on each wheel)
3	<a href="#">280-1877</a>	8" Wheel, Poly-U
4	029-0047	Snap Ring
6	<a href="#">280-1261</a>	Seat Mount Tube
7	<a href="#">280-1799</a>	Fuse, 5 AMP Mini
8	<a href="#">280-1228</a>	Circuit Breaker, 15 AMP
9	<a href="#">280-0006</a>	Mart Cart 24" Seat
10	<a href="#">280-1264</a>	Basket Tube (see options pg. 6)
11	<a href="#">200-1802</a>	Basket, LIL Max (see options pg. 6)
12	200-1236	Basket Mounting Clip (4)
13	<a href="#">200-1052</a>	2" Caster
14	<a href="#">280-2012</a>	Hub Motor/Wheel/Tire, GREEN
15	see pg. 3	Steering Column
16	<a href="#">280-1214</a>	Battery, 35 Ahr
17	<a href="#">200-1553</a>	Seat Switch
18	<a href="#">280-1936</a>	12 VDC Charger - 10 AMP

Item	Part No.	Description
19	<a href="#">280-1712</a>	Main Wire Harness/Battery Cover Assy.
20	<a href="#">280-1943</a>	Steering Wire Harness w/Connectors
21	<a href="#">280-1281</a>	Floor Cover
22	280-1280	Rear Cover (select color option)
23	280-1279	Front Cover (select color option)
24	<a href="#">280-1711</a>	Spring Latch for Seat
25	<a href="#">280-1935</a>	Motor Controller
26	<a href="#">280-1646</a>	Wire Harness (see note) Controller to Motor
27	<a href="#">280-1269</a>	Fork Assembly
28	<a href="#">280-1441</a>	Bridge Cover
29	<a href="#">280-1346</a>	Tire/Outer Shell
30	<a href="#">280-1797</a>	Charging Cord, coiled
31	<a href="#">280-1626</a>	Wire Guide (see note)
32	<a href="#">280-1840</a>	Rear Bumper
33	see pg. 3	Control Box
34	<a href="#">280-1614</a>	Basket bumpers (gray)
35	<a href="#">280-1637</a>	Cord Cover (see note)
36	280-0093	Bushing, Spacer
37	<a href="#">280-1659</a>	Cord Cover Lid (see note)

NOTE: #31 (wire guide) and #26 (wire harness) can be ordered as an assembly part [280-1656](#)

#35 (cord cover) & #37 (cord cover lid) can be ordered as an assembly part [280-0004](#)

## Optional Parts

Item	Part #	Description
1	290-1385	Small Basket
2	280-1374	Jumbo Basket (w/castors & lower shelf)
3	200-8153	Folding Produce Tray
4	280-1586	Check-Writer
5	280-1653	Safety Flag
6	<a href="#">200-1393</a>	Cord Reel - 6'
7	280-1956	Hour Meter
8	280-1609	Crutch Holder Assembly (for basket)
9	<a href="#">280-1440</a>	Seat Latch Hook Assembly
10	<a href="#">280-1833</a>	Crutch Holder Assembly (for seat)





# MATERIAL SAFETY DATA SHEET

Product Name: Sealed Maintenance Free Lead-Acid Batteries

DATE: 1/5/2005 ISSUED BY: ENGINEERING TELEPHONE NO.: 479-636-3245

## HAZARDOUS COMPONENTS

COMPONENTS	WEIGHT %	TLV	LD50	LC50	LC50
			ORAL	INHALATION	CONTACT
Lead (Pb, PbO <sub>2</sub> , PbSO <sub>4</sub> )	about 70%	N/A	(500) mg/kg	N/A	N/A
Sulfuric Acid	about 20%	1mg/m <sup>3</sup>	(2,140) mg/kg	N/A	N/A
Fiberglass Separator	about 5%	N/A	N/A	N/A	N/A
ABS Plastic	about 5%	N/A	N/A	N/A	N/A

## PHYSICAL DATA

COMPONENTS	DENSITY	MELTING POINTS	SOLLUBILITY (H <sub>2</sub> O)	ODOR	APPEARANCE
Lead	11.34	327.4° C (Boiling)	None	None	Silver-Gray Metal
Lead Sulfate	6.2	1070° C (Boiling)	40 mg/(15° C)	None	White Powder
Lead Dioxide	9.4	290° C (Boiling)	None	None	Brown Powder
Sulfuric Acid	about 1.3	about 114° C (Boiling)	100%	Acidic	Clear Colorless Liquid
Fiberglass Separator	N/A	N/A	Slight	Toxic	White Fibrous Glass
ABS Plastic	N/A	N/A	None	No Odor	Solid

## FLAMMABILITY DATA

COMPONENTS	FLASHPOINT	EXPLOSIVE LIMIT	COMMENTS
Lead	None	None	
Sulfuric Acid	None	None	
Hydrogen		4% - 72.4%	Sealed batteries can emit hydrogen if over charged (float voltage > 2.40 VPC).
Fiberglass Separator	N/A	N/A	Toxic vapors may be released. In case of fire, wear self-contained breathing apparatus.
ABS Plastic	None	N/A	Temp. over 300° C (572° F) may release combustible gases. In case of fire: wear positive pressure self-contained breathing apparatus.

## FIRST AID

### SULFURIC ACID PRECAUTIONS

Skin Contact:	Flush with water, see physician if contact area is large or if blisters form.
Eye Contact:	Call physician immediately and flush with water until physician arrives.
Ingestion:	Call physician. If patient is conscious, flush mouth with water, have patient drink milk or sodium bicarbonate solution. National Poison Center: 1-800-222-1222

## REACTIVITY DATA

COMPONENT	Sulfuric Acid
STABILITY	Stable at all temperatures
COLYMERIZATION	Will not polymerize
INCOMPATIBILITY	Reactive metals, strong bases, most organic compounds
DECOMPOSITION PRODUCTS	Sulfuric dioxide, trioxide, hydrogen sulfide, hydrogen
CONDITIONS TO AVOID	Prohibit smoking, sparks, etc. from battery charging area. Avoid mixing acid with other chemicals

## SPILL OR LEAK PROCEDURES

Steps to take in case of leak or spill:	If sulfuric acid is spilled from a battery, neutralize acid with bicarbonate (baking soda), sodium carbon (soda ash), or calcium oxide (lime). Flush area with water and discard to the sewage system. Do not allow unneutralized acid into sewage system.
Waste disposal method:	Neutralized acid may be flushed down the sewer. Spent batteries must be treated as hazardous waste and disposed of according to local, state, and federal guidelines. A copy of this MSDS must be supplied to any scrap dealer or secondary lead smelter with battery.

## PROTECTION

EXPOSURE SITE	PROTECTION	COMMENTS
SKIN	Rubber gloves, Apron	Protective equipment must be worn if the battery is cracked or otherwise damaged. A respirator should be worn during reclaim operations if the TLV is exceeded.
RESPIRATORY	Respirator (for lead)	
EYES	Safety goggles, Face Shield	

## ELECTRICAL SAFETY

Due to the battery's low internal resistance and high power density, high levels of short circuit current can be developed across the battery terminals. Do not rest tools or cables on the battery. Use insulated tools only. Follow all installation instructions and diagrams when installing or maintaining battery systems.

## HEALTH HAZARD DATA

**LEAD:** The toxic effects of lead are accumulative and slow to appear. It affects the kidneys, reproductive, and central nervous systems. The symptoms of lead overexposure are anemia, vomiting, headache, stomach pain (lead colic), dizziness, loss of appetite, and muscle and joint pain. Exposure to lead from a battery most often occurs during lead reclaim operations through the breathing or ingestion of lead dust or fumes.

**SULFURIC ACID:** Sulfuric acid is a strong corrosive. Contact with acid can cause severe burns on the skin and in eyes. Ingestion of sulfuric acid will cause GI tract burns. Acid can be released if the battery case is damaged or if vents are tampered with.

**FIBERGLASS SEPARATOR:** Fibrous glass is an irritant of the upper respiratory tract, skin and eyes. For exposure up to 10F/CC use MSA Comfofill with type H filter. Above 10F/CC up to 50F/CC use Ultra-Twin with type H filter. This product is not considered carcinogenic by NTP or OSHA.

ALL DATA MUST BE PASSED TO ANY SCRAP DEALER OR SMELTER WHEN BATTERY IS RESOLD.



115 E. Linden • Rogers, Arkansas 72756 USA  
 (479) 636-5776 • Fax: (479) 636-3245  
**International** (001) 479-636-5776  
 www.martcart.com  
 800-548-3373