

IMPORTANT DOCUMENT - DELIVER TO MANAGER



OWNER'S MANUAL and TECHNICAL DOCUMENTATION

MODEL 4038



FOR UL (Underwriter Laboratories) APPROVED CARTS

Mart Cart® is a quality product line of Assembled Products® Corporation

115 E. Linden • Rogers, Arkansas 72756 USA
(479) 636-5776 • (479) 636-3245 fax
1-800-548-3373 www.martcart.com

E



Important Information

Please read before operation.

CONGRATULATIONS!

You have just purchased the best electric shopping cart on the market today. Mart Cart incorporates the very latest in technological advances. To assure you of the best and safest performance as well as longest life, please read the enclosed information. After reading this manual, should you have a service problem or need help, please call our customer service department with the serial number of your cart, at our toll free number: **1-800-548-3373 or (479) 636-5776**.

DAMAGE: Check the shipping carton for any visible damage. Report the damage to the freight carrier immediately. File a claim with the carrier if actual damage to your cart has occurred. Check the contents of the carton. The contents should agree with the information listed on the packing list. Report any discrepancy to the carrier and the factory immediately.

TO ORDER PARTS: Call **1-800-548-3373 or (479) 636-5776** or visit **www.martcart.com**. Be sure to give the serial number to the service department personnel. The Mart Cart serial number is located on the seat support tube under the seat as shown in parts list portion of this manual.

TERMS: All parts will be shipped with approved credit card, check in advance or C.O.D. Commercial accounts are allowed 15 day terms from date on invoice with approved credit.

FREIGHT: All freight will be paid by the customer. Special consideration will be given to items under warranty coverage.

ATTENTION: It is the responsibility of the owner of this cart to maintain the cart in a safe and reliable operating condition at all times.

NOTE: Specifications found in this manual are subject to change without notice.

Important Safety Instructions

Please read before operation.

WARNINGS!

- Never attempt to charge the battery in this cart without using an electrical outlet that is protected by a GFCI.
- Replace charging cord if plug is damaged or if the cord is worn or frayed.
- Never use the charging cord without proper grounding. Do not use if plug does not have all 3 prongs.
- Never allow the cart to be used out-of-doors or on any surface that is not level.
- Always disconnect power before servicing.
- See "Daily Maintenance Checklist" and follow instructions.
- Cart can roll. Enter and exit the cart with care.
- Replace parts using only factory-specified, original equipment from the manufacturer for your specific model. Failure to do so may void warranty, affect operation of the cart, and result in injury.

OPERATING PROCEDURES

- New carts will need charging! Charge the cart's battery for 8 hours prior to first use.
- **THIS CART IS FOR USE INDOORS, ON LEVEL SURFACE ONLY.**
- **DO NOT STAND ON CART.** (See "Operating & Warning Instructions" on cart).
- After battery is charged, disconnect power supply cord before operating cart.
- **DO NOT** exceed the load limitations as shown on the cart.
- Return power cord to the cord storage area when not charging.
- **DO NOT** allow children to operate or play on cart. Keep cart secured with key (if applicable), at service counter.

Your cart is equipped with the Intelli-Charge™ system. While operating the cart, the LED (Light Emitting Diode) will be solid **green** until the battery runs lower than 2/3 full charge. It will then turn **amber**. When the battery charge falls below 11 volts, the LED will begin flashing **red**. The customer riding the cart should have ample time to return the cart to the charging station before the power is cut off to the motor. When the customer exits the cart, the horn will start beeping in unison with the **red** flashing LED. This will alert those responsible for maintaining the cart to plug in the charger. When plugged into a 120v AC wall socket, the LED will flash **amber** and the horn will silence. When charging is complete, the LED will start flashing **green**. The charger may be left plugged in even longer. It will **NOT** harm the battery.

LED Color Status	Description
LED Off	Off/On rocker switch is set to "Off" position or no one is sitting in the seat
Green	Off/On rocker switch is set to "On" position and someone is sitting in the seat
Amber	Battery's charge is below 2/3 full charge
Red – Flashing	Battery needs to be charged
Amber – Flashing	Charger is plugged in and battery is being charged
Green – Flashing	Charger is plugged in and the battery is charged

- The battery should be charged each night and at every opportunity. The battery is fully charged when the LED on the control box flashes **green**.
- A Ground Fault Circuit Interrupter (GFCI) in the circuit is required wherever the cart is being charged.
- Before servicing the cart, the battery should be charged to a voltage above the "depletion" level (above 11 volts).
- Never allow the battery to completely "discharge." This will cause premature battery failure.

Inspection and Service Recommendations

The following list outlines the inspection and service recommendations to be performed on a daily basis and during all service work. While they may not be presented on this list, all parts and components of the cart should be checked for proper functionality and either fixed or reported to authorized store/facility personnel upon completion of service.

All parts and configurations must be Original Equipment Manufacturer (OEM) to ensure proper safety, warranty compliance, and UL compliance. In the event that any part(s) or system does not pass inspection, the cart should be marked as "Out of Service," stored in a location not accessible by store/facility customers, and reported to maintenance personnel/provider. Also see "Daily Maintenance Check List" posted on cart and the recommendations below.

- **General Condition:** Frequency = daily and during service. Check for broken frame, tubes, bumpers (frame and basket), basket, handlebars, covers, and seat. Replace as necessary. Any part or piece that may snag a person or object (such as a store display) should be repaired. All mounting screws (e.g. front cover screws) should be checked and replaced as necessary. Repair or replace any component that would cause a potential "Safety Hazard."
- **Charger cord:** Frequency = daily and during service. Replace cord if it is worn or frayed, or 3-pronged plug is broken. Replace with OEM cord only. Do not splice. Be sure power outlets provide protection through an operating Ground Fault Circuit Interrupter (GFCI).
- **Anti-Tip Casters and Brackets:** Frequency = daily and during service. Check for proper distance from the floor (1/8 to 1/2 inch). Check for bracket welds and position (parallel to the floor). Replace caster and/or bracket if broken or bent.
- **Seat and Seat Latch:** Frequency = daily and during service. Tighten if necessary. If cracks or rust occur, or if seat rocks loosely, replace at once. Ensure that the latch engages properly and that it secures the seat from tilting forward.
- **Horn:** Frequency = daily and during service. Check for proper functionality and audible level. The horn should activate when pressed or when the cart is moving in reverse.
- **Grips:** Frequency = daily and during service. Check the grips on the handlebars to ensure that they firmly grip the handlebars. The grips should not be easily twisted or removed.
- **Seat Switch:** Frequency = daily and during service. Ensure that the cart only moves under power when someone is sitting in the seat activating the seat safety switch. Cart must stop when weight is removed from seat.
- **Throttle:** Frequency = daily and during service. Test for smooth "start," acceleration, deceleration, and "stop." Repair if necessary.
- **Charger:** Frequency = while charging and during service. Check the "inhibit" functionality of the charger. Ensure that the cart does not move under power when plugged into a power outlet and charging the battery.
- **Electrical Components:** Frequency = during service. Check all wiring to ensure no evidence of fraying, crimps or cuts. Ensure that the harness is lying inside the rear pan and not in a bind or making contact with metal parts or components that could rub through the insulation. Ensure proper fuses are installed. Use only specified fuses (see decal next to fuse holders).
- **Wheels and Axle:** Frequency = during service. Ensure that wheels are properly aligned, bearings are functional. Check for flat spots and wear.
- **Contacts of Switches:** This cart is equipped with switches that are non-serviceable. The switches are UL-recognized and have been tested for this application. If any switch does not function as intended, replace immediately.
- **Cleanliness:** Inspect and clean the cart daily; keeping the cart free from accumulation of grease, dirt, and other possibly combustible materials.
- **Motor and Brake:** test the motor wheel and its brake daily. Drive the cart in forward and then reverse to insure the motor is able to move the cart. To check the brake which is internal in the motor wheel, sit on the cart and leave the throttle in the neutral position, place each foot on the floor on both sides of the cart and try to push the cart. The brake should prevent the motor wheel from turning. Note that if pushed hard enough the tire may skid on the floor. If the cart fails this test, take the cart out of service and call for repair.

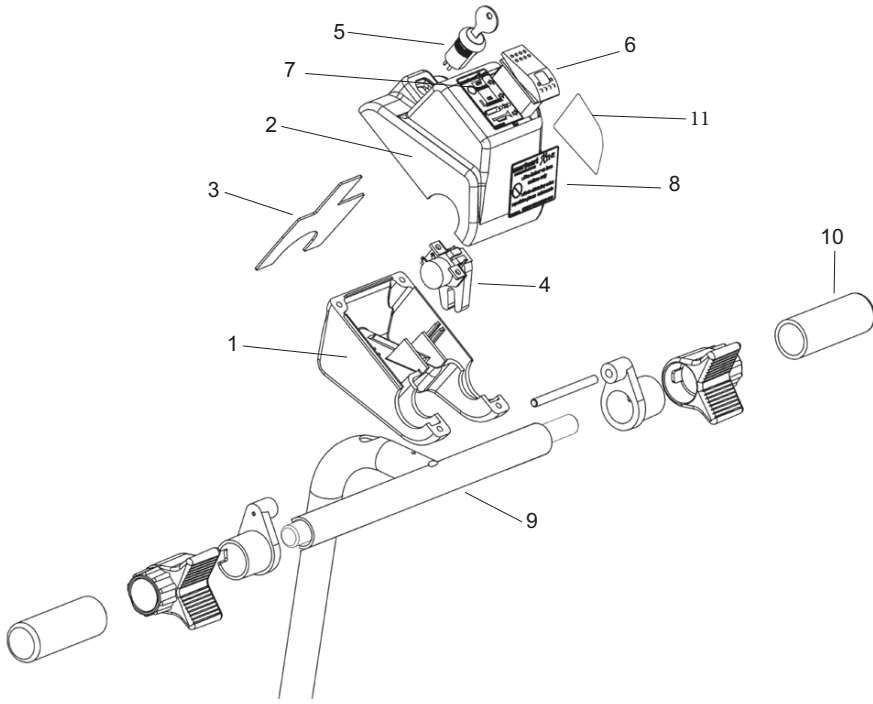

CONTROL BOX PARTS LIST

COMPONENTS

Item	Part #	Description
1	280-1178	Control Box Bottom Cover
2	280-1177	Control Box Top Cover
3	280-1184	Control Box Divider
4	280-1249	Potentiometer Assembly
5	200-1640	Key Switch (optional)
6	280-1405	Rocker Switch Assembly
7	280-1863	Top Control Box Overlay
8	280-1837	Front Control Box Overlay
9	280-1199	Steering Column w/Rod & Grips
10	280-1602	Grip, PVC-FREE
11	280-1862	Intelli-Charge™ Indicator Decal

CONTROL BOX KITS

Part #	Description
280-1878	Control Box, Keyless (1-4, 6-8, 11)
280-1879	Control Box, Keyed (1-8, 11)
280-1880	Control Box, Top, Keyless (2, 4, 6-8, 11)
280-1881	Control Box, Top, Keyed (2, 4, 5, 6-8, 11)
280-1882	Box Top with Decals (2, 7, 8, 11)

WIRING DIAGRAM

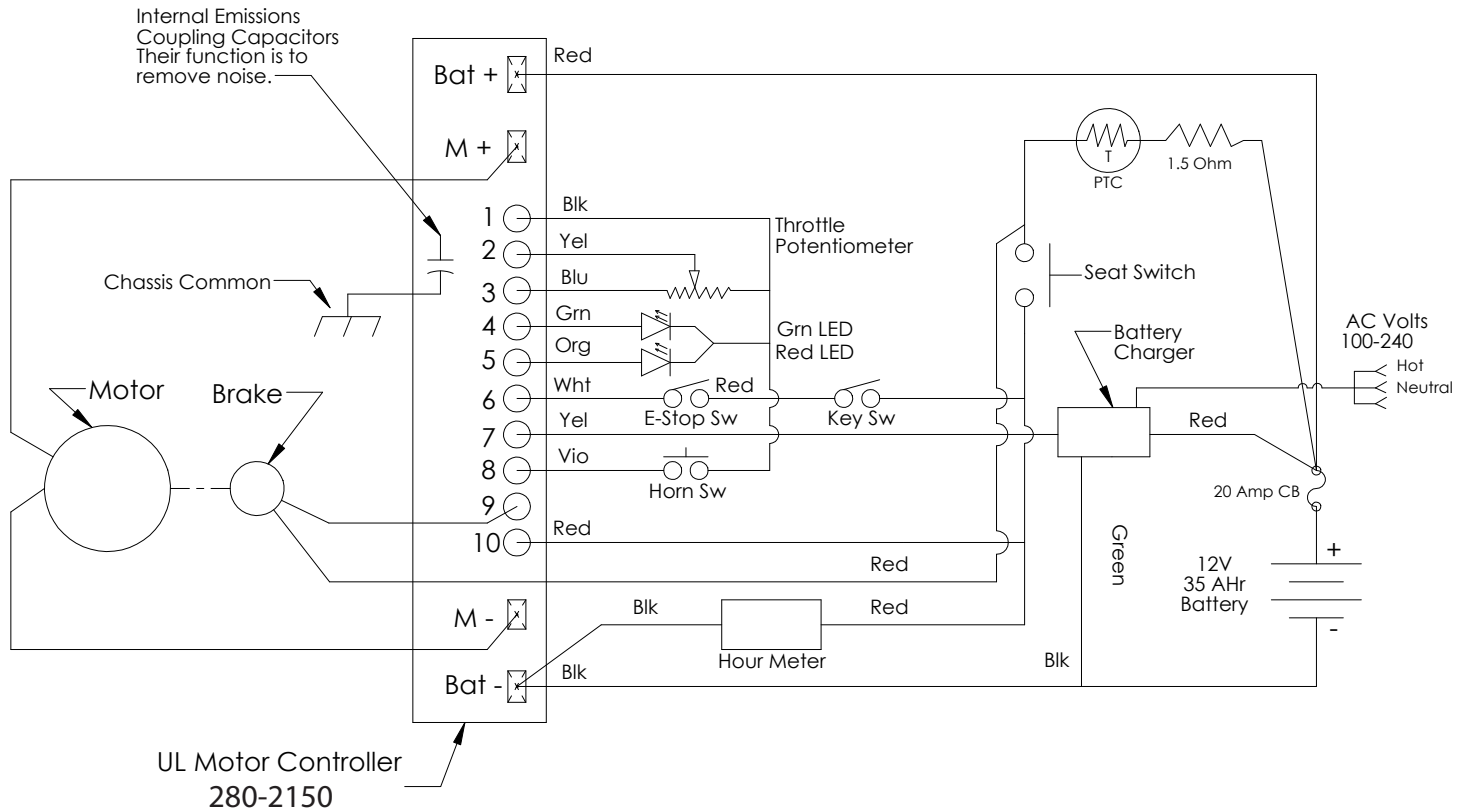

CART PARTS LIST

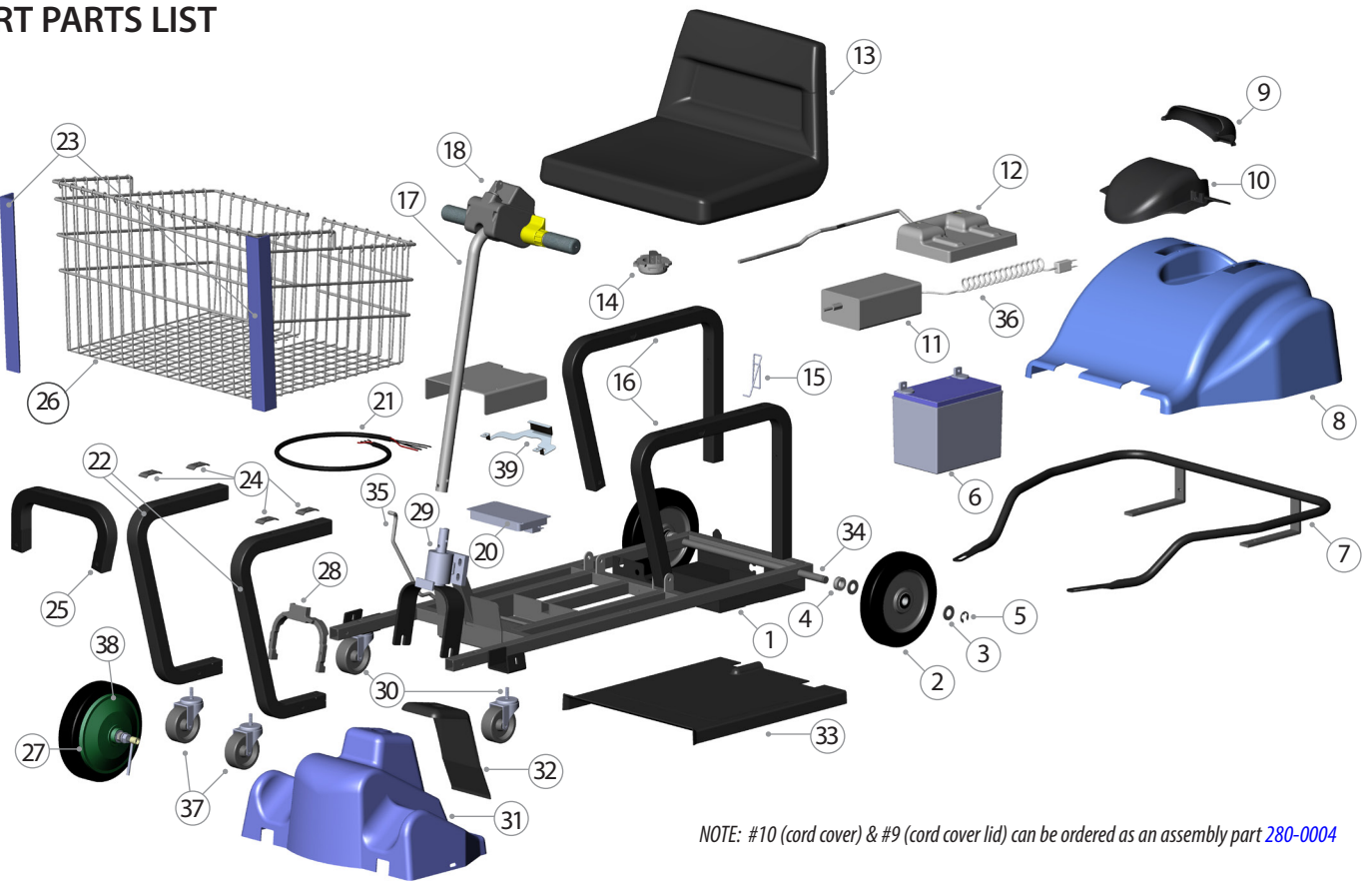

NOTE: #10 (cord cover) & #9 (cord cover lid) can be ordered as an assembly part [280-0004](#)

Item	Part No.	Description
1	280-1818	Frame, Bumper, and Hardware
2	280-1877	Rear Wheels, Poly-U
3	020-0064	Bushing – 5/8" (2 on each wheel)
4	280-1335	Grommet – 5/8" (1 on each wheel)
5	029-0047	Snap Ring (1 on each wheel)
6	280-1214	Battery – 35 AH
7	280-1814	Bumper, Rear
8	280-2018	Rear Cover
8A	280-1638	Rear Cover Fastener (Kit – not shown)
9	280-1659	Lid, Cord Cover (see note)
10	280-1637	Cord Cover (see note)
11	280-0057	Charger, UL 10 amp
12	280-0044	Main Wire Harness Assembly (with battery cover & 20A Circuit Breaker)
12A	280-0046	20A Circuit Breaker
13	280-1798	Seat (includes Seat Switch)
14	200-1553	Seat Switch
15	280-1711	Seat Latch Assembly
16	280-1261	Seat Tube
17	280-1199	Steering Column (see detail on page 4)
18	See pg. 4	Control Box
20	280-0229	UL Motor Controller
21	280-0032	Steering Wire Harness
22	280-1394	Tube, Basket, JUMBO, UL

Item	Part No.	Description
23	280-1034	Basket Bumpers, with rods
24	200-1236	Basket Mounting Clips (4 each)
25	280-1370	Basket Tube Cross Brace
26	280-1597	Basket, Jumbo (hardware & signs)
27	280-2012	Hub Motor (with tire)
28	280-1626	Wire Guide
29	280-1269	Steering Fork Assembly
30	200-1052	Anti-tip Casters
31	280-1417	Front Cover
31A	280-1638	Front Cover Fastener (Kit – not shown)
32	280-1441	Bridge Cover
33	280-1281	Floor Cover
34	280-1259	Axle, Steel, 5/8"
35	280-1839	Hub to UL Motor Controller Wire Harness
35A	280-0038	Wire Guide Assembly (Includes Hardware)
36	280-1823	Charging Cord (not shown)
37	280-1784	3" Castor
38	280-1346	Outer Shell with Tread
39	280-0142	Controller Hold Down Bracket

— DECALS FOUND ON MART CART® ELECTRIC SHOPPING CART —

Please call 1-800-548-3373 if your decals are missing or are needing replacement.

Standard decals and signs are English and Spanish (see part numbers below). Call for other languages.

<p>280-1570-02</p> <p>OPERATING INSTRUCTIONS PLEASE READ BEFORE OPERATING</p> <ol style="list-style-type: none"> Turn key on and/or press the "Run" switch. Thumb levers rotate to power the cart. Press top lever forward to go forward. Press bottom lever down to go in reverse. To stop, release the thumb levers and/or press the "stop" switch. If needed, ask cashier for assistance to get your items to your vehicle. Under no circumstances are carts to be taken outside the store. <p>DO NOT REMOVE FROM STORE</p>	<p>INSTRUCCIONES DE OPERACION LEA ANTES DE USAR</p> <ol style="list-style-type: none"> Prenda la llave y/o apriete el interruptor de encendido. Las palancas del pulgar giran para accionar el carrito. Apriete la palanca para avanzar hacia adelante. Presione la palanca inferior hacia abajo para conducir de reversa. Para detenerse, suelte la palanca o presione el botón de "alto". De ser necesario, pida ayuda a algún empleado de la tienda para llevar sus compras a su vehículo. Bajo ninguna circunstancia deberá sacar el carrito fuera de la tienda. <p>NO SAQUE ESTE CARRITO DE LA TIENDA</p>
--	--

280-1570

<p>200-1387-07</p> <p>WARNING PLEASE READ TO AVOID PERSONAL INJURY. USE AT YOUR OWN RISK! INTENDED FOR USE INDOORS ON LEVEL SURFACE ONLY!</p> <ol style="list-style-type: none"> Read operating instructions or ask for assistance before using. Use extra caution getting "ON" or "OFF" cart. Cart is on wheels and may roll. You must be seated to operate cart. Keep feet and legs inboard while operating. Do not stand on cart. Do not lean "ON" or "OVER" the side of the cart. NO CHILDREN IN BASKET. 	<p>ADVERTENCIA FAVOR LEER PARA EVITAR ACCIDENTES. USE BAJO SU PROPIO RIESGO. DESTINADO PARA USO DENTRO DE LAS INSTALACIONES Y EN SUPERFICIES PLANAS.</p> <ol style="list-style-type: none"> Lea las instrucciones de operación o pida ayuda antes de usar. Tenga mucha precaución al "SUBIR" y "BAJAR" del carrito. No olvide que el carrito esta sobre ruedas. Usted tiene que estar sentado para operar el carrito. Mantenga los pies y piernas en el carrito cuando lo este usando. Favor de no pararse en el carrito. No se recargue "EN ni "SOBRE" el costado del carrito. No ponga niños en la canastilla.
---	---

200-1387

WARNING
TO PREVENT PERSONAL INJURY FROM ELECTRICAL SHOCK - DO NOT USE CHARGING CORD IF:

- THE ELECTRICAL CORD OR PLUG IS DAMAGED OR WORN. REPLACE BEFORE USING.
- THE ELECTRICAL CORD OR PLUG IS NOT PROTECTED BY A GROUND FAULT CIRCUIT INTERRUPTER (GFCI).
- THE ELECTRICAL CORD OR PLUG IS OF A DIFFERENT TYPE.

Para PREVENIR una HERIDA PERSONAL DE un GOLPE ELÉCTRICO - no UTILICE LA CUERDA DE CARGAR SI:

- LA SALIDA ELÉCTRICA no ESTÁ PROTEGIDA POR UN INTERRUPTOR de CIRCUITO por un DEFECTO de TIERRA (GFCI).
- LA CUERDA o el TAPON ELÉCTRICO están DAÑADOS o GASTADOS. REEMPLACE ANTES de UTILIZAR UNICAMENTE con CUERDA de 3 ALAMBRES y TAPON DEL MISMO TIPO.

200-1299

DO NOT STAND ON BUMPER

280-2103-00

PULL LATCH UNDERNEATH TO REMOVE COVER

280-1307-02

280-1307

ASSEMBLED PRODUCTS CORP - MART CART
115 E. LINDEN ST. ROGERS, AR 72756
SERIAL # UL-01100 MODEL 280-4037
MANUFACTURING DATE: MONTH: YEAR: 2013 2014 2015
1 2 3 4 5 6 7 8 9 10 11 12

280-1186

CAUTION
HIGH VOLTAGE
Disconnect power before servicing

280-1183

WARNING
DISCONNECT CHARGING CORD BEFORE OPERATION

280-1868

280-1868

PATENTED
U.S. PATENT NO. 7108090 B2

280-3007

280-3007

UL LISTED
ELECTRIC-BATTERY-POWERED CART FOR COMMERCIAL USE
3ST4

280-4000

LOAD LIMITS
MAXIMUM PERSONS (1)
MAXIMUM WEIGHT:
RIDER **550 LBS.**
BASKET **200 LBS.**

280-1625

280-1625

WARNING
DISCONNECT CHARGING CORD BEFORE OPERATION

WARNING
DISCONNECT CHARGING CORD BEFORE OPERATION

280-1869

280-1869

Warning
FIRE HAZARD. USE ONLY 280-1214 MART CART BATTERY.
DO NOT MODIFY THE WIRING HARNESS OR THE BATTERY COVER.

280-1774

280-1774

BATTERY CHARGER
INPUT: 100-240VAC - 50/60Hz 3AMPS (MAX)
OUTPUT: DC 12V/7AMPS

BATTERY INFORMATION
CAPACITY: 35Ahr @ 20Hr / NOMINAL 2.0AMPS
BATT. REORDER MODEL: 280-1214
HEIGHT 6.25" X WIDTH 8.625" X DEPTH 5.25"

NOTICE
THIS CART MUST BE USED INDOORS ONLY!
FOR USE ON LEVEL SURFACE ONLY!

FUSES LOCATED UNDER REAR COVER - REPLACE WITH EXACT TYPE

280-1838 UL Listed xxxxxxxx

280-1835

For owners manuals visit www.martcart.com

mart cart

1-800-548-3373 or 1-479-636-5776

280-1330

280-1330

280-1862

FULL CHARGE

HALF CHARGE

LOW CHARGE IMMEDIATELY

280-1862

CHARGE EVERY NIGHT, ALL NIGHT, AND AT EVERY OPPORTUNITY

280-1992

280-1992

STOP ALTO

FULL CHARGE

HALF CHARGE

LOW CHARGE IMMEDIATELY

280-1863

IN-CLUB USE ONLY
PARA USO EXCLUSIVO DENTRO DEL CLUB

NO CHILDREN IN BASKET!
¡NO NIÑOS EN LA CANASTA!

mart cart www.martcart.com

200-1155

200-1155

MART CART
WWW.MARTCART.COM
HANDLE GRIPS POWER THE CART
Turning up goes forward
Turning down is reverse

USE INDOORS ON LEVEL SURFACE ONLY!
DO NOT REMOVE FROM STORE!

280-1837

280-1837

IN-CLUB USE ONLY
PARA USO EXCLUSIVO DENTRO DEL CLUB

FOR OUR VALUED CUSTOMERS... BECAUSE WE CARE.

PARA NUESTROS ESTIMADOS CLIENTES... PORQUE USTED ES IMPORTANTE.

mart cart www.martcart.com

DAILY MAINTENANCE CHECK LIST
For optimum Cart availability and performance, the following items should be checked daily:

- ELECTRIC CORD and/or REEL** - Replace cord-reel if cord is worn or frayed, 3 pronged plug is broken or reel will not retract. See sure Power-Outlet provides protection through an operating Ground Fault Circuit Interrupter (GFCI)
- SEAT & MOUNTING** - Tighten if necessary. If cracks or rust occur, or if seat rocks loosely, replace at once. Lubricate swivel or tracks with vaseline as required. Make sure Seat Lock is in good working condition.
- SEAT SWITCH** - If cart is equipped with a seat switch, test and replace if not working properly. Cart must stop when weight is removed from seat.
- THROTTLE** - Test for smooth "start", acceleration, deceleration and "stop". Repair if necessary. Charge or replace battery if needed.
- ANTI-TIP CASTERS** - Replace if broken. Maintain height adjustment of 1/8" to 1/2" above floor level.
- GENERAL** - Repair or replace any component that would cause a potential "Safety Hazard".
- APPEARANCE** - Wipe off and clean as needed for customer satisfaction and for store's "Public Image".

LISTA DE MANTENIMIENTO DIARIO
Para la disponibilidad óptima y el desempeño, del Carrito, los siguientes artículos deben chequearse diario:

- LA CUERDA y/o EL CARRETE ELÉCTRICOS** - Reemplace la cuerda-carrete si la cuerda está gastada o pelonda, el tapón de 3 puntas esta roto o el carrito no retráctase. Asegure que la Salida de Poder provea protección por un Interruptor de Circuito por Defecto de Tierra (GFCI) operativo.
- EL ASIENTO Y LA SUBIDA** - Apriete si es necesario. Si grietas ocurren, se oxida o si el asiento se mueve flojamente, reemplazelo inmediatamente. Lubrique giratorio o los rastros con vaselina como sea requerido. Asegure que el Cierre del Asiento esté en buena condición para trabajar.
- COMUNICADOR DEL ASIENTO** - Si el carrito esta equipado con un conmutador del asiento, examínelo y reemplazelo si no trabaja apropiadamente. El carrito debe pararse cuando se quita peso del asiento.
- REGULADOR** - Apruébalo por el cono liso, la aceleración, la desaceleración y "paro". Repare si es necesario. Cargue o reemplace la batería si es necesario.
- LAS RUEDECILLAS DE ANTI-INCLINA** - Reemplázalas si están quebradas. Mantenga el ajuste de la altura de 1/8" a 1/2" encima del nivel de piso.
- GENERAL** - Repare o reemplace cualquier componente que causará un "riesgo de Seguridad" potencial.
- LA APARIENCIA** - Saucuda y limpie cuando sea necesario para la satisfacción del cliente y para "la Imagen Publica" de la tienda.

FOR PARTS OR SERVICE CALL **PARA PARTES O SERVICIO LLAME**
800-548-3373 or 479-636-5776 800-548-3373 o 479-636-5776 200-1127-05

200-1127

Battery Charging Instructions

Please read before charging.

- Install a Ground Fault Circuit Interrupter (GFCI) in the electrical circuit wherever the cart is to be charged. This is to protect against any possible shock hazard.
- AC voltage required is 100-240 VAC. The current draw is 3 amps maximum.
- Charge battery every night, all night, and at every opportunity. When the battery is fully charged, the charger will maintain a “float voltage” which will not damage the battery.
- Do not allow the battery to full discharge by skipping the nightly charging cycle. A fully discharged battery will take 7 hours to fully charge, so it is best not to let the battery become completely discharged.
- Do not store the cart with a discharged battery. This can cause premature battery failure. Fully charge the battery at least every 30 days if in a low usage location.

NOTE: Under normal conditions, the battery will last more than 2 years, or longer, if the above recommendations are followed. Replace with original Mart Cart battery (280-1214) only to maintain UL Certification. Mart Cart is not responsible for any adverse effects caused by replacement with any other type of battery.

IMPORTANT: Your cart has been equipped with an AGM (Absorbent Glass Mat) (Suspended Electrolyte) Battery during the manufacturing process as original equipment. The manufacturer recommends that you replace the original battery only with the same type and rating to prevent damage to your cart’s internal components, charging system, or personal injury to you and/or your customer.

Battery Replacement Instructions

Please read before replacing battery.

Be Responsible! Recycle old battery or dispose of according to local or national codes.

To Replace a Battery: (Read precautions on battery-avoid any sparks)

1. Turn off key switch (if applicable) or press Run/Stop/Horn switch to the “Stop” position. Disconnect charger cord from wall outlet, if plugged in.
2. Remove two screws from the back of the rear bumper that secures the rear cover.
3. Reach under right rear of the back cover and pull latch, then tilt the chair forward.
4. Remove tie down strap from the battery cover. ←
5. Lift the battery cover from the top of the battery.
6. Replace battery and push battery cover back down on top of the new battery.
7. Secure battery cover with strap.
8. Before reinstalling cover, check wheel condition, and general condition of the chair.
9. Reinstall rear cover with the cover’s two screws and tilt chair back into normal position.
10. Test cart for proper operation. Charge battery if necessary.

CAUTION! Do not cross battery posts with a metal object!

Additional Information

SEAT SWITCH: The seat switch is located under the seat. Pressure (weight) on the seat closes the control circuit, and allows the cart to operate.

VARIABLE SPEED CONTROL: The cart’s speed is regulated by a potentiometer. This provides extremely smooth acceleration from 0 to 2.2 MPH, and is located in the control box on the steering column.

CHARGING: HOW IT WORKS: When the power supply cord is plugged into the store’s electrical outlet, the battery charger is energized. The charger sends approximately 14.5 Volts to the battery for charging. A third wire (yellow) from the charger output inhibits the UL Motor Controller until the power to the charger is disconnected. The motor circuit is interrupted until charging cord is removed. The cart will not move under power when the battery is being charged. If the cart moves while plugged in, check for power to your outlet before calling for service.

CONTROL BOX: The master control box for the Mart Cart is located on top of the steering column. It contains the RUN/STOP/HORN switch, and key switch (optional). The cover can be removed by removing the four bottom screws.

MATERIAL SAFETY DATA SHEET

Product Name: Sealed Maintenance Free Lead-Acid Batteries

DATE: 1/5/2005 ISSUED BY ENGINEERING TELEPHONE NO. 479-636-3245

HAZARDOUS COMPONENTS

COMPONENTS	WEIGHT %	TLV	LD50	LC50	LC50
			ORAL	INHALATION	CONTACT
Lead (Pb, PbO ₂ , PbSO ₄)	about 70%	N/A	(500) mg/kg	N/A	N/A
Sulfuric Acid	about 20%	1mg/m ³	(2,140) mg/kg	N/A	N/A
Fiberglass Separator	about 5%	N/A	N/A	N/A	N/A
ABS Plastic	about 5%	N/A	N/A	N/A	N/A

PHYSICAL DATA

COMPONENTS	DENSITY	MELTING POINTS	SOLLUBILITY (H ₂ O)	ODOR	APPEARANCE
Lead	11.34	327.4° C (Boiling)	None	None	Silver-Gray Metal
Lead Sulfate	6.2	1070° C (Boiling)	40 mg/l(15° C)	None	White Powder
Lead Dioxide	9.4	290° C (Boiling)	None	None	Brown Powder
Sulfuric Acid	about 1.3	about 114° C (Boiling)	100%	Acidic	Clear Colorless Liquid
Fiberglass Separator	N/A	N/A	Slight	Toxic	White Fibrous Glass
ABS Plastic	N/A	N/A	None	No Odor	Solid

FLAMMABILITY DATA

COMPONENTS	FLASHPOINT	EXPLOSIVE LIMIT	COMMENTS
Lead	None	None	
Sulfuric Acid	None	None	
Hydrogen		4% - 72.4%	Sealed batteries can emit hydrogen if over charged (float voltage > 2.40 VPC).
Fiberglass Separator	N/A	N/A	Toxic vapors may be released. In case of fire, wear self-contained breathing apparatus.
ABS Plastic	None	N/A	Temp. over 300° C (572° F) may release combustible gases. In case of fire: wear positive pressure self-contained breathing apparatus.

FIRST AID

SULFURIC ACID PRECAUTIONS

Skin Contact:	Flush with water, see physician if contact area is large or if blisters form.
Eye Contact:	Call physician immediately and flush with water until physician arrives.
Ingestion:	Call physician. If patient is conscious, flush mouth with water, have patient drink milk or sodium bicarbonate solution. National Poison Center: 1-800-222-1222

REACTIVITY DATA

COMPONENT	Sulfuric Acid
STABILITY	Stable at all temperatures
COLYMERIZATION	Will not polymerize
INCOMPATIBILITY	Reactive metals, strong bases, most organic compounds
DECOMPOSITION PRODUCTS	Sulfuric dioxide, trioxide, hydrogen sulfide, hydrogen
CONDITIONS TO AVOID	Prohibit smoking, sparks, etc. from battery charging area. Avoid mixing acid with other chemicals

SPILL OR LEAK PROCEDURES

Steps to take in case of leak or spill:	If sulfuric acid is spilled from a battery, neutralize acid with bicarbonate (baking soda), sodium carbon (soda ash), or calcium oxide (lime). Flush area with water and discard to the sewage system. Do not allow unneutralized acid into sewage system.
Waste disposal method:	Neutralized acid may be flushed down the sewer. Spent batteries must be treated as hazardous waste and disposed of according to local, state, and federal guidelines. A copy of this MSDS must be supplied to any scrap dealer or secondary lead smelter with battery.

PROTECTION

EXPOSURE SITE	PROTECTION	COMMENTS
SKIN	Rubber gloves, Apron	Protective equipment must be worn if the battery is cracked or otherwise damaged. A respirator should be worn during reclaim operations if the TLV is exceeded.
RESPIRATORY	Respirator (for lead)	
EYES	Safety goggles, Face Shield	

ELECTRICAL SAFETY

Due to the battery's low internal resistance and high power density, high levels of short circuit current can be developed across the battery terminals. Do not rest tools or cables on the battery. Use insulated tools only. Follow all installation instructions and diagrams when installing or maintaining battery systems.

HEALTH HAZARD DATA

LEAD: The toxic effects of lead are accumulative and slow to appear. It affects the kidneys, reproductive, and central nervous systems. The symptoms of lead overexposure are anemia, vomiting, headache, stomach pain (lead colic), dizziness, loss of appetite, and muscle and joint pain. Exposure to lead from a battery most often occurs during lead reclaim operations through the breathing or ingestion of lead dust or fumes.

SULFURIC ACID: Sulfuric acid is a strong corrosive. Contact with acid can cause severe burns on the skin and in eyes. Ingestion of sulfuric acid will cause GI tract burns. Acid can be released if the battery case is damaged or if vents are tampered with.

FIBERGLASS SEPARATOR: Fibrous glass is an irritant of the upper respiratory tract, skin and eyes. For exposure up to 10F/CC use MSA Comfoil with type H filter. Above 10F/CC up to 50F/CC use Ultra-Twin with type H filter. This product is not considered carcinogenic by NTP or OSHA.

ALL DATA MUST BE PASSED TO ANY SCRAP DEALER OR SMELTER WHEN BATTERY IS RESOLD.



115 E. Linden • Rogers, Arkansas 72756 USA
(479) 636-5776 • Fax: (479) 636-3245

www.martcart.com
800-548-3373

