

PS638 Series
Electric and Gas Oven
Domestic & Standard Export

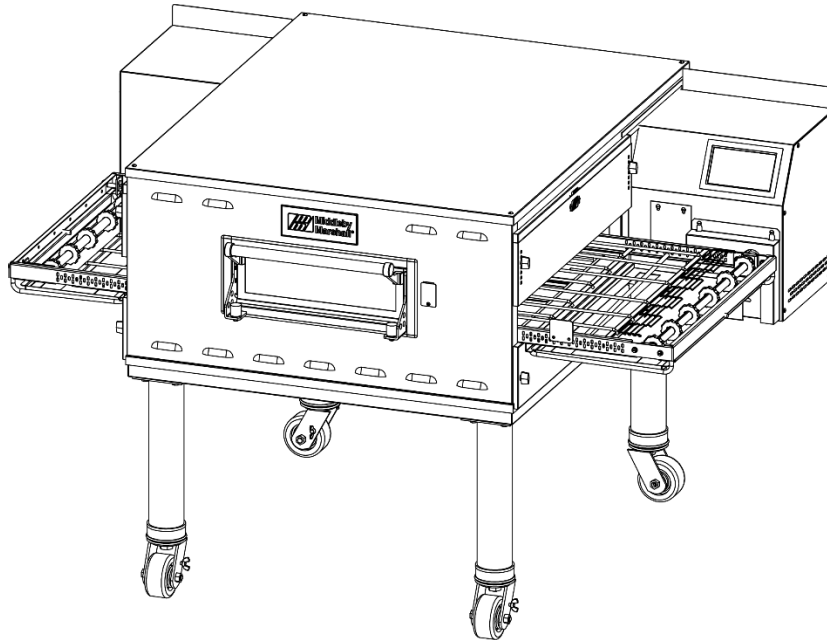

P/N: 79059
Revision D
April 15th, 2024
ENGLISH



PS638 Series Electric and Gas Ovens

Model:

- PS638E Electric
- PS638G Gas

Combinations:

- Single Oven
- Double Oven (Two-Stack)
- Triple Oven (Three-Stack)
- KOF Applications

OWNER'S OPERATING AND INSTALLATION MANUAL

for Domestic & Standard Export Ovens

© 2019 Middleby Marshall Inc.



is a registered trademark of Middleby Marshall, Inc. All rights reserved.



NOTICE:

This Owner's Operating and Installation Manual should be given to the user. The operator of the oven should be familiar with the function and operation of the oven.

This manual must be kept in a prominent, easily reachable location near the oven.

Ovens are shipped from the factory configured for use with Natural gas. If permitted by local, national and international codes, at the time of installation the oven may be converted to Propane gas operation. This conversion requires the use of a Gas Conversion Kit that is supplied with the oven. For CE-approved ovens, the conversion is described in the *Installation* section of this manual. For domestic and standard export ovens, instructions are included in the Gas Conversion Kit.

It is recommended to obtain a service contract with a Middleby Authorized Service Company (ASC).

WARNING

POST IN A PROMINENT LOCATION, THE EMERGENCY TELEPHONE NUMBER OF YOUR LOCAL GAS SUPPLIER AND INSTRUCTIONS TO BE FOLLOWED IN THE EVENT YOU SMELL GAS.

INSTRUCTIONS TO BE FOLLOWED IN THE EVENT THE USER SMELLS GAS SHALL BE OBTAINED BY CONSULTING THE LOCAL GAS SUPPLIER. IF THE SMELL OF GAS IS DETECTED, IMMEDIATELY CALL THE EMERGENCY PHONE NUMBER OF YOUR LOCAL GAS COMPANY. THEY WILL HAVE PERSONNEL AND PROVISIONS AVAILABLE TO CORRECT THE PROBLEM.

WARNING

DO NOT SPRAY AEROSOLS IN THE VICINITY OF THIS APPLIANCE WHILE IT IS IN OPERATION.

FOR YOUR SAFETY

DO NOT STORE OR USE GASOLINE OR OTHER FLAMMABLE VAPORS OR LIQUIDS IN THE VICINITY OF THIS OR ANY OTHER APPLIANCE.

WARNING: IMPROPER INSTALLATION, ADJUSTMENT, ALTERATION, SERVICE OR MAINTENANCE CAN CAUSE PROPERTY DAMAGE, INJURY OR DEATH. READ THE INSTALLATION, OPERATING AND MAINTENANCE INSTRUCTIONS THOROUGHLY BEFORE INSTALLING OR SERVICING THIS EQUIPMENT.

MESURE DE SÉCURITÉ

NE PAS ENTREPOSER NI UTILISER D'ESSENCE NI AUTRES VAPEURS OU LIQUIDES INFLAMMABLES À PROXIMITÉ DE CET APPAREIL OU DE TOUT AUTRE APPAREIL!

AVERTISSEMENT: L'INSTALLATION, LE RÉGLAGE, LA MODIFICATION, LA RÉPARATION OU L'ENTRETIEN INCORRECTS DE CET APPAREIL PEUVENT CAUSER DES DOMMAGES MATÉRIELS, DES BLESSURES OU LA MORT. LIRE ATTENTIVEMENT LES INSTRUCTIONS D'INSTALLATION, DE FONCTIONNEMENT ET D'ENTRETIEN AVANT DE PROCÉDER À SON INSTALLATION OU ENTRETIEN.

IMPORTANT

An oven electrical wiring diagram is located in this manual and inside the machinery compartment.

IMPORTANT

It is the customer's responsibility to report any concealed or non-concealed damage to the freight company. Retain all shipping materials until it is certain that the equipment has not suffered concealed shipping damage.

NOTICE

CONTACT YOUR MIDDLEBY AUTHORIZED SERVICE COMPANY TO INSTALL AND PERFORM MAINTENANCE AND REPAIRS AND IF NECESSARY TO CONVERT EQUIPMENT FOR USE WITH OTHER GASES. AN AUTHORIZED SERVICE COMPANY DIRECTORY IS SUPPLIED WITH YOUR OVEN AND AVAILABLE HERE: WWW.MIDDLEBY-MARSHALL.COM

NOTICE

Using parts other than genuine Middleby Marshall factory manufactured parts relieves the manufacturer of all warranty and liability.

NOTICE

Middleby Marshall (Manufacturer) reserves the right to change specifications at any time.

NOTICE

The equipment warranty is not valid unless the oven is installed, started, and demonstrated under the supervision of a factory authorized installer.

NOTICE

THE EQUIPMENT IS ONLY FOR PROFESSIONAL USE AND SHALL BE USED BY QUALIFIED PERSONNEL.

RETAIN THIS MANUAL FOR FUTURE REFERENCE

TABLE OF CONTENTS

SECTION 1 - DESCRIPTION.....	5	VIII. PS638G GAS SPECIFICATIONS	21
I. OVEN USES.....	5	A. Natural Gas	21
II. OVEN COMPONENTS – SEE FIGURE 1-1	5	B. Propane Gas	21
A. Conveyor Drive Motor (inside cabinet).....	5	C. NATURAL GAS PRESSURE ADJUSTMENT [Factory Pre-Set]	21
B. Crumb Pans.....	5	D. GAS CONVERSION.....	21
C. Conveyor	5	E. ULPG Orifice Conversion Procedure.....	22
D. End Plugs	5	F. ULPG Pressure Adjustment	22
E. Eyebrows	5	SECTION 3 – OPERATION	23
F. Window (Optional)	5	I. DESCRIPTION OF CONTROLS – USER INTERFACE	23
G. Control Cabinet Doors	5	A. Standby/Splash Screen.....	23
H. Serial Plate	5	B. Preheat Screen	24
I. Control Panel (User Interface)	5	C. Manual Cooking	24
J. Photo Sensor (Optional)	5	D. Preset Cooking.....	25
K. Door Photo Sensor (Optional).....	5	II. NORMAL OPERATION.....	26
L. Circuit Breaker Resets.....	5	A. Daily Start-up Procedure	26
M. Burner or Heater (inside left control cabinet)	5	B. Adjusting the Temperature – Manual Mode.....	26
N. Blowers (not shown)	5	C. Adjusting the Belt Time – Manual Mode.....	26
O. Fingers (inside oven cavity)	5	D. Adjusting Settings – Preset Mode	26
III. OVEN SPECIFICATIONS – PS638E.....	6	E. Daily Shutdown Procedure (Turning the Oven Off) .	26
Table 1-1 Dimensions	6	A. Changing Baking Blower Speeds (Manual).....	26
Table 1-2: General Specifications	6	B. Changing Energy Mode Status.....	26
Table 1-3: Electrical Specifications.....	6	C. System Setup.....	26
Table 1-4: Heater Amperage	6	D. Energy Management Information	27
IV. OVEN SPECIFICATIONS – PS638G.....	7	SECTION 4 - MAINTENANCE	29
Table 1-1 Dimensions	7	I. MAINTENANCE – DAILY	29
Table 1-2: General Specifications	7	II. MAINTENANCE – MONTHLY	30
Table 1-3: Electrical Specifications.....	7	III. MAINTENANCE – EVERY 6 MONTHS	31
Table 1-4: Gas Orifice and Pressure Specifications	7	IV. VENTLESS OVEN CATALYST CARE	32
Table 1-5: Gas Orifice and Pressure Specifications (Per Oven Cavity) – CE Ovens.....	7	V. PS638E & G OVEN KEY SPARE PARTS.....	33
SECTION 2 - INSTALLATION.....	3	SECTION 5 - WIRING DIAGRAMS	35
I. GENERAL	3	SECTION 6 - ASSEMBLY DRAWINGS	40
II. PS638 OVEN INSTALLATION – BASE/TOP KITS & EQUIPMENT	4		
A. Loose Parts & Kits for PS638 Series Oven Installation Kits (PN 74121-E & 74075-G).....	4		
B. P/N: 71687 – SINGLE OVEN BASE & TOP KIT	5		
C. P/N: 73754 – DOUBLE OVEN BASE & TOP KIT	6		
D. P/N: 73556 – TRIPLE OVEN BASE & TOP KIT	7		
III. PS638 OVEN LAYOUTS	8		
A. Single Oven	8		
B. Double and Triple Oven	10		
IV. VENTILATION SYSTEM	12		
A. Requirements	12		
B. Recommendations	12		
C. Other Ventilation Concerns.....	12		
V. ASSEMBLY	13		
A. Top Panel and Base Pad Assembly	13		
B. Stacking.....	14		
C. Restraint Cable Installation	14		
D. Conveyor Installation	15		
E. Final Assembly	16		
VI. ELECTRICAL SUPPLY	16		
VII. GAS SUPPLY	19		
A. Gas Utility Rough-In Recommendations	19		
B. Connection.....	19		
C. Gas Conversion	19		
D. PS638G Propane/ULPG Conversion	20		
E. Adjusting the Maximum Pressure Setting	20		
F. Checkout	20		
G. Maintenance	20		
H. Gas Train with Orificed By-Pass.....	20		

**MIDDLEBY MARSHALL
NO QUIBBLE LIMITED WARRANTY
(U.S.A. ONLY)**

MIDDLEBY MARSHALL HEREINAFTER REFERRED TO AS "THE SELLER", WARRANTS EQUIPMENT MANUFACTURED BY IT TO BE FREE FROM DEFECTS IN MATERIAL AND WORKMANSHIP FOR WHICH IT IS RESPONSIBLE. THE SELLER'S OBLIGATION UNDER THIS WARRANTY SHALL BE LIMITED TO REPLACING OR REPAIRING AT SELLER'S OPTION, WITHOUT CHARGE, ANY PART FOUND TO BE DEFECTIVE AND ANY LABOR AND MATERIAL EXPENSE INCURRED BY SELLER IN REPAIRING OR REPLACING SUCH PART. SUCH WARRANTY SHALL BE LIMITED TO THE ORIGINAL PURCHASER ONLY AND SHALL BE EFFECTIVE FOR A PERIOD OF ONE YEAR FROM DATE OF ORIGINAL INSTALLATION OR 18 MONTHS FROM DATE OF PURCHASE, WHICHEVER IS EARLIER, PROVIDED THAT TERMS OF PAYMENT HAVE BEEN FULLY MET.

This warranty is valid only if the equipment is installed, started, and demonstrated under the supervision of a factory-authorized installer.

Abuse, acts of God, belt jams, cleaning, customer abuse, insufficient utilities, lubrication, maintenance, non-oven related issues, preventative maintenance, or normal maintenance function including adjustment of airflow, burners, conveyor components, door mechanisms, microswitches, pilot burners, thermostats, and replacement of bushings, light bulbs, fuses, indicating lights and wear points, are not covered by this **no quibble limited warranty**.

Seller shall be responsible only for repair or replacement of defective parts performed by Seller's authorized service personnel. Authorized service companies are located in principal cities throughout the contiguous United States, Alaska, and Hawaii. This warranty is valid in the 50 United States and is void elsewhere unless the product is purchased through Middleby International with warranty adder included.

The foregoing warranty is exclusive and in lieu of all other warranties, expressed or implied. There are no implied warranties of merchantability or of fitness for a particular purpose.

The foregoing shall be the Seller's sole and exclusive obligation and Buyer's sole and exclusive remedy for any action, including breach of contract or negligence. In no event shall Seller be liable for a sum in excess of the purchase price of the item. Seller shall not be liable for any prospective or lost profits of the buyer.

This warranty is effective on Middleby Marshall equipment sold on, or after January 1st, 2007.

© 2018 - Middleby Marshall, A Middleby Company.

**MIDDLEBY MARSHALL
OVEN LIMITED WARRANTY
(Non U.S.A.)**

The Seller warrants equipment manufactured by it to be free from defects in material and workmanship for which it is responsible. The Seller's obligation under this warranty shall be limited to replacing or repairing, at Seller's option, without charge, F.O.B. Seller's factory, any part found defective and any labor and material expense incurred by Seller in repairing or replacing such part. Such warranty is limited to a period of one year from the date of original installation or 15 months from date of shipment from Seller's factory, whichever is earlier, provided that terms of payment have been fully met. All labor shall be performed during regular working hours. Overtime premium will be charged to the Buyer.

This warranty is not valid unless equipment is installed, started, and demonstrated under the supervision of a factory-authorized installer.

Normal maintenance functions including lubrication, adjustment of airflow, thermostats, door mechanisms, microswitches, burners and pilot burners, and replacement of light bulbs, fuses, and indicating lights, are not covered by warranty.

Any repair or replacement of defective parts shall be performed by Seller's authorized service personnel. Seller shall not be responsible for any costs incurred if the work is performed by anyone other than the Seller's authorized service personnel.

When returning any part under warranty, the part must be intact and complete, without evidence of misuse or abuse, freight prepaid.

Seller shall not be liable for any consequential damages of any kind which occurs during the course of installation of equipment, or which results from the use or misuse by Buyer, its employees, or others, of the equipment supplied hereunder, at Buyer's sole and exclusive remedy against Seller for any breach of the foregoing warranty or otherwise shall be for the repair or replacement of the equipment or parts thereof affected by such breach.

The foregoing warranty shall be valid and binding upon Seller if and only if Buyer loads, operates and maintains the equipment supplied hereunder in accordance with the instruction manual provided to Buyer. Seller does not guarantee the process of manufacture by Buyer or quality of product to be produced by the equipment supplied hereunder and Seller shall not be liable for any prospective or lost profits of Buyer.

The foregoing shall be Seller's sole and exclusive obligation and Buyer's sole and exclusive remedy for any action, whether in breach of contract or negligence. In no event shall Seller be liable for a sum in excess of the purchase price of the item.

THE FOREGOING WARRANTY IS EXCLUSIVE AND IN LIEU OF ALL OTHER EXPRESS AND IMPLIED WARRANTIES WHATSOEVER, SPECIFICALLY THERE ARE NO IMPLIED WARRANTIES OF MERCHANTABILITY OR FITNESS FOR A PARTICULAR PURPOSE.

SECTION 1 - DESCRIPTION

I. OVEN USES

The PS638 Series Continuous Batch WOW Conveyor Ovens can be used to bake, cook, crisp, dry, heat, or finish a wide variety of products, such as catering, pastries, pizza, pizza-type products, cookies, sandwiches, and other items

II. OVEN COMPONENTS – See Figure 1-1

A. Conveyor Drive Motor (inside cabinet)

Moves the Conveyor Belting (65756).

B. Crumb Pans

Catch crumbs and other materials that drop through the conveyor belt. One crumb pan is located at each end of the conveyor belt.

C. Conveyor

Moves the food product through the oven.

D. End Plugs

Allow access to the oven's interior.

E. Eyebrows

Can be adjusted to various heights to lessen heat loss to the environment (72709).

F. Window (Optional)

Allows the user to access the food products within the baking chamber, or place product into the oven for shorter bake times (51054).

G. Control Cabinet Doors

Allow access to the oven's control components. No user serviceable parts are located within these cabinets.

H. Serial Plate

Provides specifications for the oven pertinent to installation, operation and maintenance. Refer to Section 2, Installation for details.

I. Control Panel (User Interface)

Allows user to adjust temperature, bake time, and top and bottom air flow. Also provides diagnostic messages for oven operation.

J. Photo Sensor (Optional)

Puts oven into the Baking Mode when the beam is interrupted by product being placed on the belt (72209).

K. Door Photo Sensor (Optional)

Puts oven into the Baking Mode when the beam is interrupted by the front window being opened to insert product.

L. Circuit Breaker Resets

Permits resetting breakers inside control cabinet without opening control door or directly touching the circuit breakers.

M. Burner or Heater (inside left control cabinet)

Heat recirculating air within the plenum and oven cavity.

N. Blowers (not shown)

Move heated air that recirculates through the oven cavity.

O. Fingers (inside oven cavity)

Direct air in controlled fashion to the product being baked through a highly specialized pattern arrangement of extruded holes. See Standard Finger Arrangement (73555).

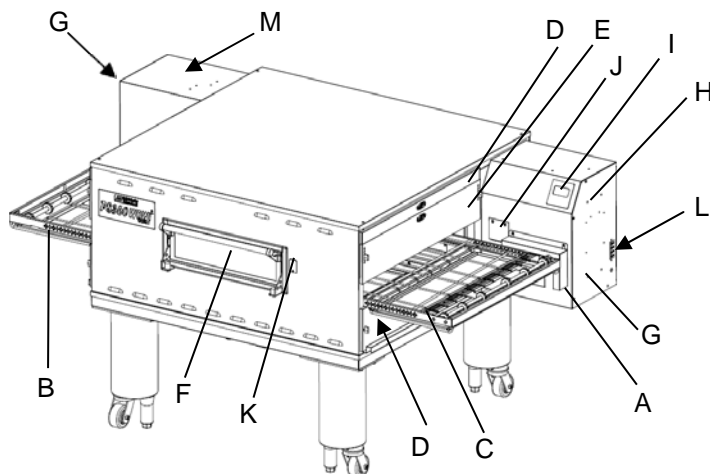
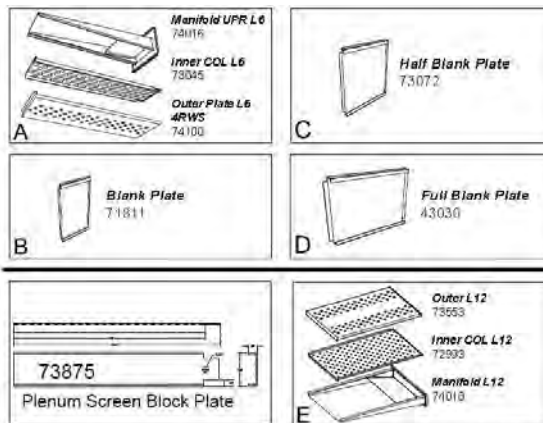
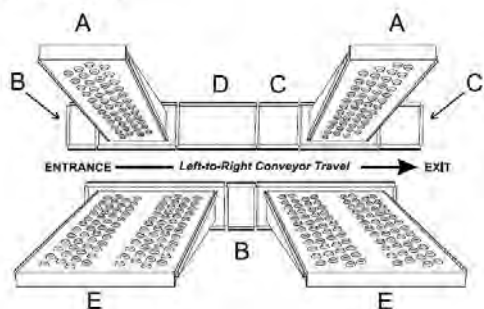

Figure 1-1



Left-to-Right configuration is shown:
Upper Air Block P/R / 2875 QTY (2) Installed in Top Air
Pressure P/R & L.T. 3000

For Right-to-Left - 1/2 mirror image



Finger Arrangement P/N 73555, Rev. B, 04/16

III. OVEN SPECIFICATIONS – PS638E

Table 1-1 Dimensions	<i>Single Oven</i>	<i>Double Oven</i>	<i>Triple Oven</i>
Overall Height	41.9" (1,064 mm)	51.23" (1,301 mm)	63.47" (1,612 mm)
Overall Depth	50" (1,270 mm)	50" (1,270 mm)	50" (1,270 mm)
Overall Length	65.21" (1,656 mm)	65.21" (1,656 mm)	65.21" (1,656 mm)
Conveyor Width – Belt width is 25" (635 mm)	26.9" (683.3 mm)	26.9" (683.3 mm)	26.9" (683.3 mm)

Recommended Minimum Clearances

Rear of Oven to Wall	0" (0 mm)
Right Side of Oven to Wall	0" (0 mm)
Left Side of Oven to Wall	0" (0 mm)

Table 1-2: General Specifications

PS638E

Weight	838 lbs. (380 kg)	1,676 lbs. (760 kg)	2,514 lbs. (1,140 kg)
Rated Heat Input (per oven cavity)	208/240V: 22.0 kW (79.2 MJ/h)		380V: 20.25 kW (72.9 MJ/h)
Maximum Operation Temperature	600°F (315°C)		
Air Blowers	2 at 2,145 rpm		
Warm-up Time	15 minutes to 500°F		

Table 1-3: Electrical Specifications

Main Blower & Element Voltage	Control Circuit Voltage	Phase	Frequency	Current Draw	Poles	Wires
208 VAC	24 VDC	3φ	50/60 Hz	80 Amps	3	4 Wire 3 hot, 1 ground
240 VAC	24 VDC	3φ	50/60 Hz	70 Amps	3	4 Wire 3 hot, 1 ground
380 VAC	24 VDC	3φ	50/60 Hz	50 Amps	4	5 Wire 3 hot, 1 neutral, 1 ground

Table 1-4: Heater Amperage

Voltage	kW	Average Amps			
		L1	L2	L3	L4
208 VAC	22.0	63	63	63	60
240 VAC	22.0	54	54	54	51
380 VAC	20.25	39	39	35	35
380 VAC CE	18.0	37.4	37.4	27.4	27.4

NOTE

Wiring diagrams are contained in Section 5 of this manual and are also located inside the oven control compartment. Additional electrical information is provided on the oven's serial plate.

IV. OVEN SPECIFICATIONS – PS638G

Table 1-1 Dimensions

	<i>Single Oven</i>	<i>Double Oven</i>	<i>Triple Oven</i>
Overall Height	41.9" (1,064 mm)	51.23" (1,301 mm)	63.47" (1,612 mm)
Overall Depth	50" (1,270 mm)	50" (1,270 mm)	50" (1,270 mm)
Overall Length	65.21" (1,656 mm)	65.21" (1,656 mm)	65.21" (1,656 mm)
Conveyor Width – Belt width is 25" (635 mm)	26.9" (683.3 mm)	26.9" (683.3 mm)	26.9" (683.3 mm)

Recommended Minimum Clearances

Rear of Oven to Wall	0" (0 mm)
Right Side of Oven to Wall	0" (0 mm)
Left Side of Oven to Wall	0" (0 mm)

Table 1-2: General Specifications

PS638E

Weight	820 lbs. (372 kg)	1,640 lbs. (744 kg)	2,460 lbs. (1,488 kg)
Rated Heat Input (per oven cavity)	89,000 BTU/hr (93.9MJ/h, 26.1 kW)		
Maximum Operation Temperature	600°F (315°C)		
Air Blowers	2 at 1,650 rpm		
Warm-up Time	15-20 minutes to 500°F		

Table 1-3: Electrical Specifications

Main Blower Voltage	Control Circuit Voltage	Phase	Frequency	Current Draw	Poles	Wires
208/240 VAC, 3φ	24 VDC	1	50/60 Hz	4.5 Amps Run 10 Amps Start	2	3 Wire L1, L2/N, & GND

Table 1-4: Gas Orifice and Pressure Specifications

Gas Type	Main Orifice Diameter	Inlet Pressure	Manifold Pressure	Bypass Orifice
Natural Gas	#39 = 0.0995" (2.527 mm) (72023)	7-9" W.C. (1.7 – 2.2 kPa)	3.5" W.C. at manifold (0.87 kPa)	#49 = 0.073" (1.854 mm) (59145)
Propane/UPLG	0.0689" (73785) (1.75 mm)	12-14" W.C. (3.0-3.5 kPa)	6.0" W.C. at manifold (1.49 kPa)	#55 = 0.052" (1.321 mm) (49948)

Table 1-5: Gas Orifice and Pressure Specifications (Per Oven Cavity) – CE Ovens

Gas Type	Main Orifice Diameter	Orifice Pressure											Orifice Manifold Pressure	Rated Heat Input
		I2H	I2L	I2E	I2E+	I3P	I3P	I3B/P	I3B/P	I3B/P	I3B/P	I3+		
Natural G20	#39 0.0995" 2.527 mm	20 mbar	--	20 mbar	20/25 mbar	--	--	--	--	--	--	--	3.5" w.c. 8.7 mbar	25.9 kW
Natural G25	#39 0.0995" 2.527 mm	--	25 mbar	--	--	--	--	--	--	--	--	--	3.5" w.c. 8.7 mbar	25.9 kW
Butane G30	0.0689" 1.75 mm	--	--	--	--	--	--	28-30/50 mbar	30 mbar	37/50 mbar	28-30 mbar	6.0" w.c. 14.9 mbar	29.2kW	
Propane G31	0.0689" 1.75 mm	--	--	--	--	37 mbar	50 mbar	--	30 mbar	37/50 mbar	37 mbar	6.0" w.c. 14.9 mbar	29.2kW	

NOTE

Wiring diagrams are contained in Section 5 of this manual and are also located inside the oven control compartment. Additional electrical information is provided on the oven's serial plate.

THIS MANUAL MUST BE KEPT FOR FUTURE REFERENCE

SECTION 2 - INSTALLATION

I. GENERAL

WARNING – After any conversions, readjustments, or service work on the oven:

- Perform a gas leak test
- Test for proper combustion and gas supply
- Test for correct air supply, particularly to the burner
- Check that the ventilation system is in operation

WARNING – Keep the appliance area free and clear of combustibles.

WARNING – The oven must be installed on even (level) non-flammable flooring and any adjacent walls must not be flammable. Recommended minimum clearances are specified in Section 1, Description of this manual.

WARNING – Do not obstruct the flow of ventilation air to and from the oven. There must be no obstruction around or underneath the oven. Constructional changes to the area where the oven is installed shall not affect the air supply to the oven.

CAUTION: To reduce the risk of fire, the appliance is to be mounted on floors of non-combustible construction with noncombustible flooring and surface finish and with no combustible material against the underside thereof, or on noncombustible slabs or arches having no combustible material against the underside thereof, such construction shall in all cases extend not less than 12 inches (304 mm) beyond the equipment on all sides.

CAUTION: For additional installation information, contact your local Authorized Service Agent.

NOTE – There must be adequate clearance between the oven and combustible construction. Clearance must also be provided for servicing and proper operation.

NOTE – An electrical wiring diagram for the oven is located inside the machinery compartment.

NOTE: All aspects of the oven installation, including placement, utility connections, and ventilation requirements, must conform to any applicable local, national, and/or international codes. These codes supersede the requirements and guidelines provided in this manual.

NOTE: In the USA, the oven installation must conform to local codes. In the absence of local codes, gas oven installations must conform to the National Fuel Gas Installation Code, ANSI Z223.1. Gas and electric ovens, when installed, must be electrically grounded in accordance with local codes, or in the absence of local codes, with the National Electric Code (NEC), or ANSI/NFPA 70.

NOTE: In Canada, the oven installation must conform to local codes. In the absence of local codes, gas oven installations must conform to the Natural Gas Installation Code, CAN/CGA-B149.1 or Propane Gas Installation Code, CAN/CGA-B149.2, as applicable. Gas and electric ovens, when installed, must be electrically grounded in accordance with local codes, or in the absence of local codes, with Canadian Electrical Code, CSA C22.2.

NOTE: In Australia, the oven installation must conform to AS/NZ5601 and carry local Authority or any other relevant statutory regulations.

II. PS638 OVEN INSTALLATION – BASE/TOP KITS & EQUIPMENT

TYPE OF INSTALLATION	PS638 Installation Kit	Single Oven Kit Base w/ 15" Legs, Casters & Top	Double Oven Kit Base w/ 6" Legs, Casters & Top	Triple Oven Kit Base, Casters & Top
PS638E Single Electric Oven	74121	One (1) PN 71687	--	--
PS638E Double Electric Oven	74121	--	One (1) PN 73754	--
PS638E Triple Electric Oven	74121	--	--	One (1) PN 73556
PS638G Single Gas Oven	74075	One (1) PN 71687	--	--
PS638G Double Gas Oven	74075	--	One (1) PN 73754	--
PS638G Triple Gas Oven	74075	--	--	One (1) PN 73556

A. Loose Parts & Kits for PS638 Series Oven Installation Kits (PN 74121-E & 74075-G)

GAS OR ELECTRIC	ITEM NUMBER	PART NUMBER	DESCRIPTION	QTY
Gas	1	22361-0001	Flexible Gas Hose 3/4"	1
Gas	2	72782	Tap and Adapter	1
Both	3	72836	Conveyor End Stop	1
Optional	not shown	51054	Glass Door & Handle Assy	1
Both	not shown	75057 & 75058	Crumb Pans	2
Gas	not shown	62307	Manual Ball Gas Valve	1

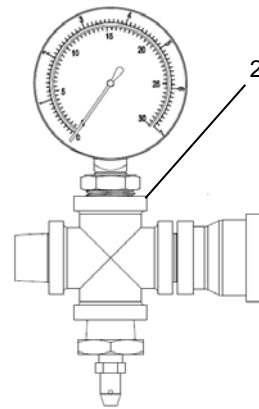
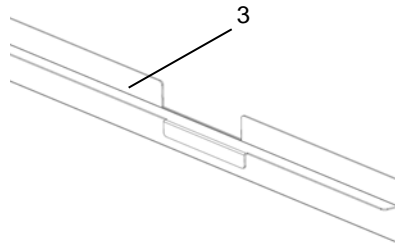
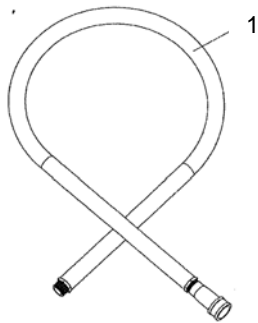

B. P/N: 71687 – SINGLE OVEN BASE & TOP KIT

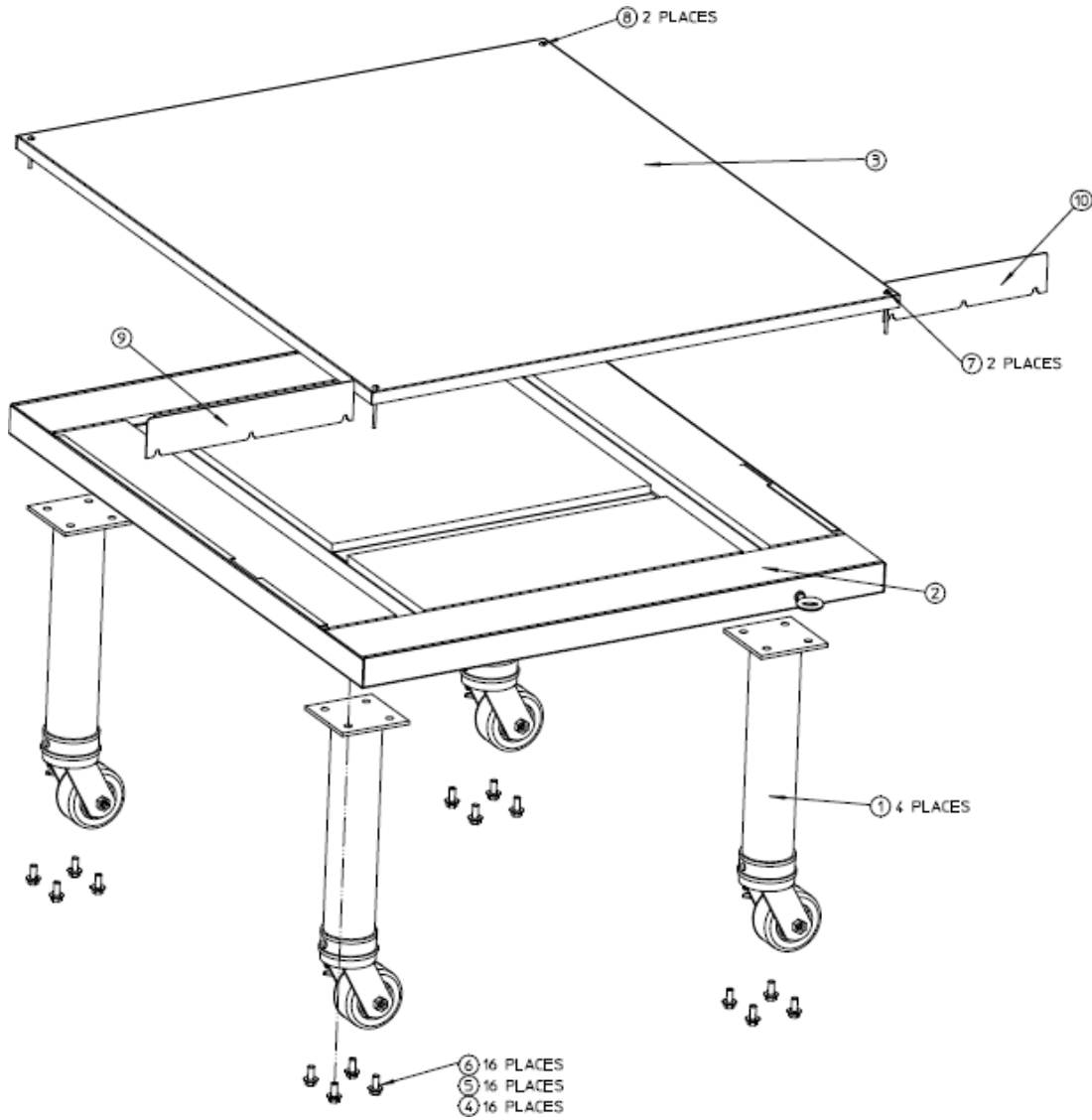

10	1	73771	GUARD,CTRL BOX LH FILLER
9	1	73772	GUARD,CTRL BOX RH FILLER
8	2	71457	SCR,SL TRUS HD SS 10-32X2
7	2	73543	SCR,SL TRUS HD SS 10-32X2,75"
6	16	2000531	SCR,CAP HX HD 3/8-16X1 NP
5	16	21416-0001	WASHER,FLAT SS 3/8
4	16	21422-0001	WASHER,LOCK SPLIT 3/8 ZP
3	1	72655	COVER,TOP PS638
2	1	71688	ASSY,BASE PS638
1	4	66948	LEG,15" COMMON TUBE
ITEM	QTY	PART NO.	DESCRIPTION

C. P/N: 73754 – DOUBLE OVEN BASE & TOP KIT

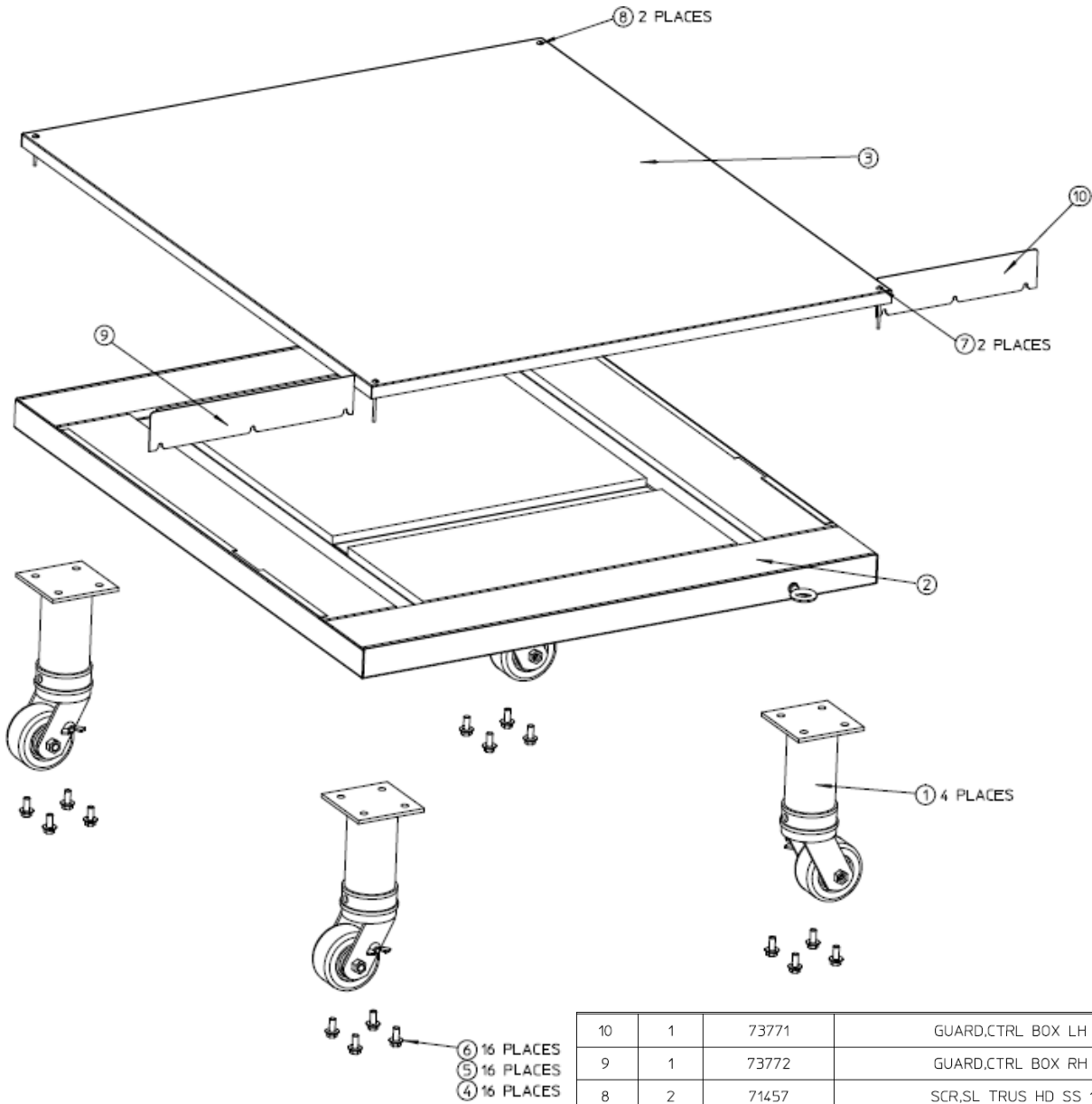

10	1	73771	GUARD,CTRL BOX LH FILLER
9	1	73772	GUARD,CTRL BOX RH FILLER
8	2	71457	SCR,SL TRUS HD SS 10-32X2
7	2	73543	SCR,SL TRUS HD SS 10-32X2.75'
6	16	2000531	SCR,CAP HX HD 3/8-16X1 NP
5	16	21416-0001	WASHER,FLAT SS 3/8
4	16	21422-0001	WASHER,LOCK SPLIT 3/8 ZP
3	1	72655	COVER.TOP PS638
2	1	71688	ASSY,BASE PS638
1	4	66946	LEG,6' COMMON TUBE
ITEM	QTY	PART NO.	DESCRIPTION

D. P/N: 73556 – TRIPLE OVEN BASE & TOP KIT

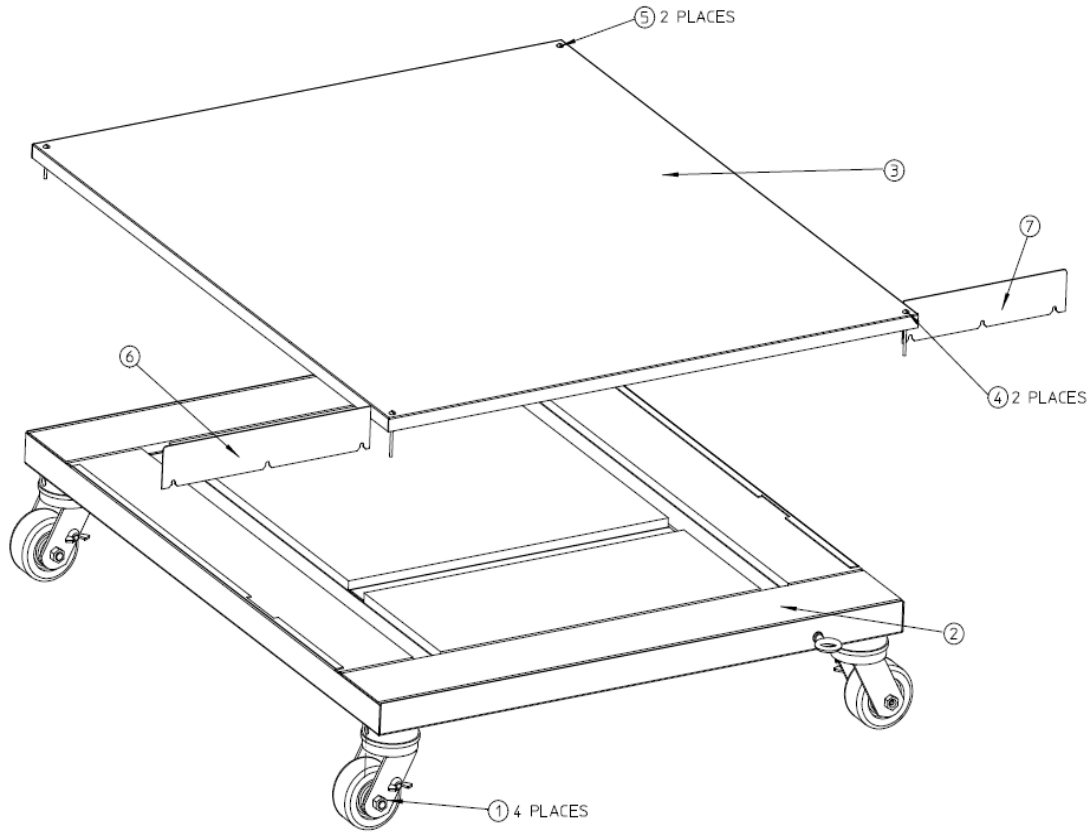

7	1	73771	GUARD,CTRL BOX LH FILLER
6	1	73772	GUARD,CTRL BOX RH FILLER
5	2	71457	SCR,SL TRUS HD SS 10-32X2
4	2	73543	SCR,SL TRUS HD SS 10-32X2.75"
3	1	72655	COVER,TOP PS638
2	1	71688	ASSY,BASE PS638
1	4	74319	CASTER,STUD W/BRAKE 4" WHEEL
ITEM	QTY	PART NO.	DESCRIPTION

III. PS638 OVEN LAYOUTS

A. Single Oven



Electrically Heated Conveyor Oven

NOTE: Height dimensions are shown for standard leg extensions. Customer-specific leg extensions will affect these dimensions.

NOTE: All units are shown with casters. CE-approved ovens use 6"/152mm adjustable feet instead of casters.

PS638E-1

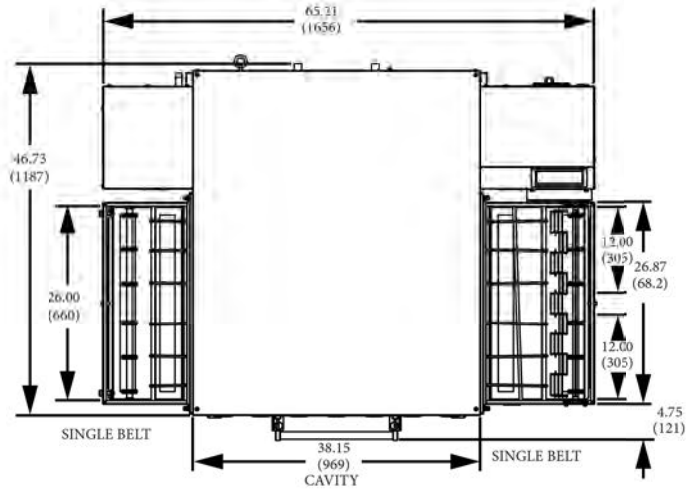

TOP VIEW

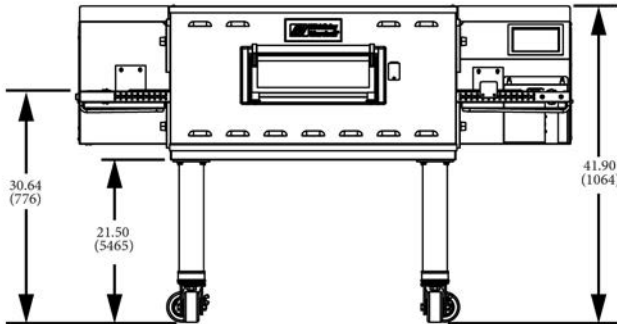

FRONT VIEW

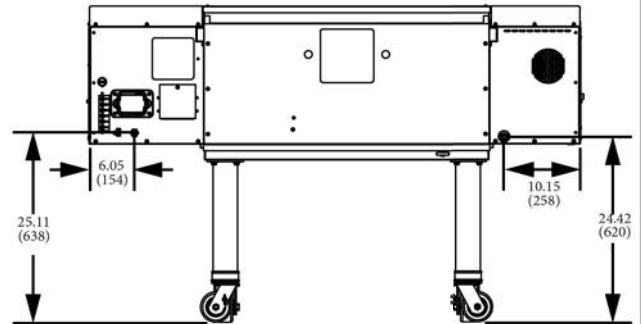

BACK VIEW

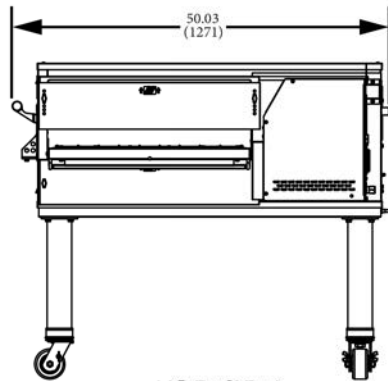

SIDE VIEW

NOTE: Drawings show ovens equipped with casters.

PS638G Single Oven

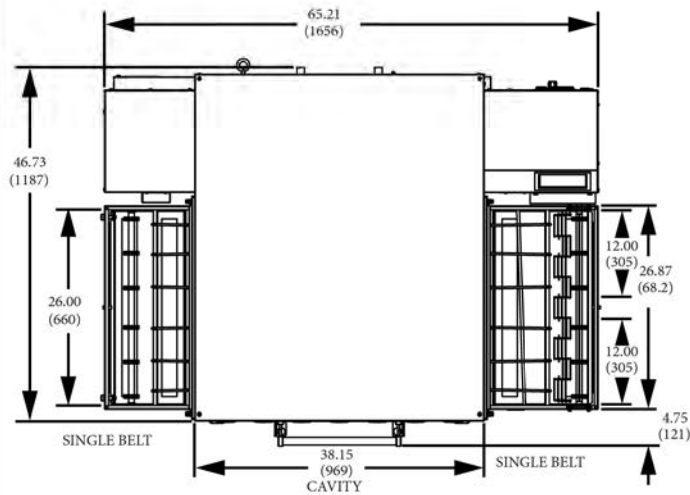

TOP VIEW

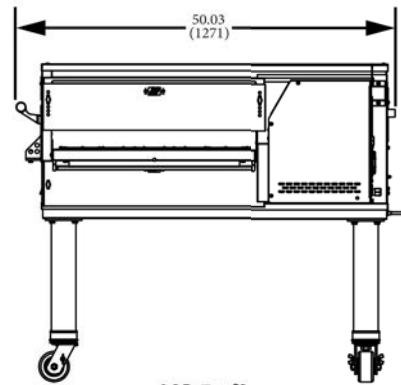

SIDE VIEW

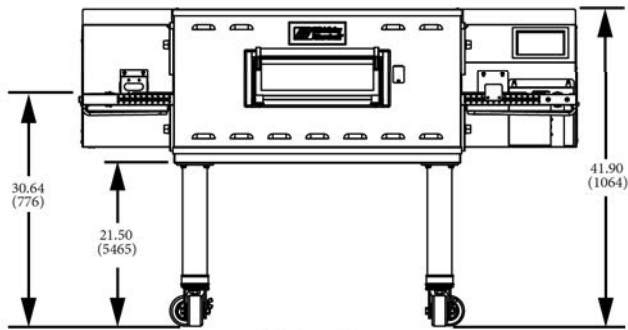

FRONT VIEW

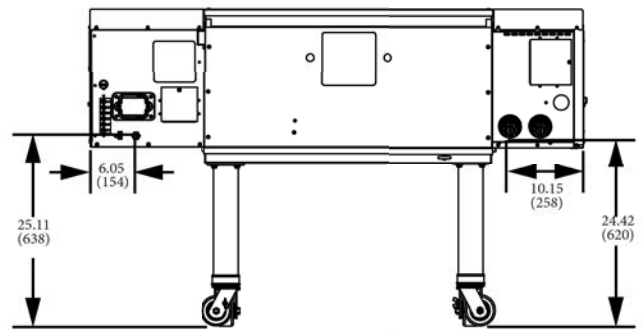

BACK VIEW

B. Double and Triple Oven



Electrically Heated Conveyor Oven

NOTE: Height dimensions are shown for standard leg extensions. Customer-specific leg extensions will affect these dimensions.

NOTE: All units are shown with casters. CE-approved ovens use 6"/152mm adjustable feet instead of casters

PS638E-2

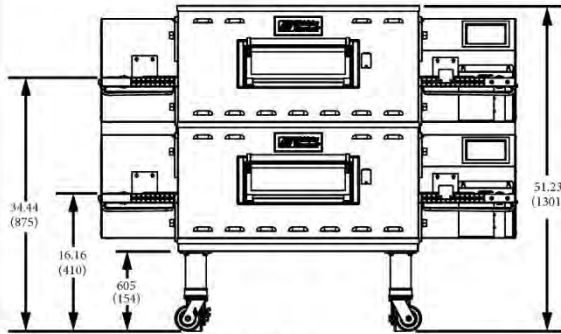

FRONT VIEW

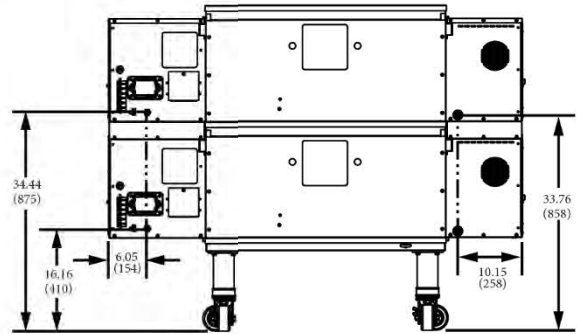

BACK VIEW

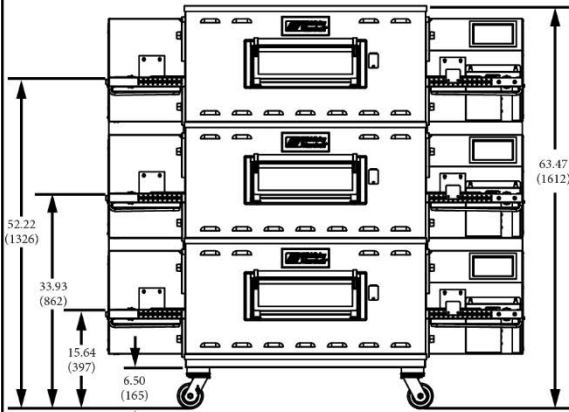

FRONT VIEW

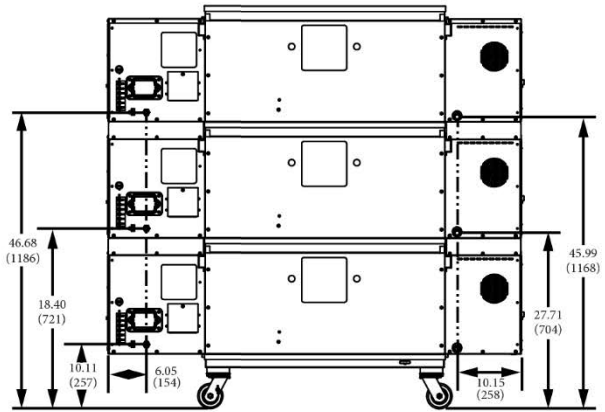

BACK VIEW

PS638-2 Double Oven

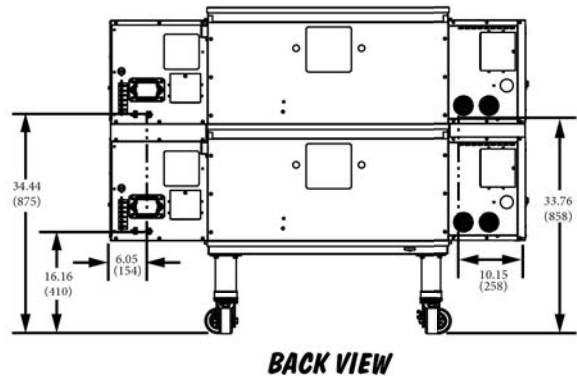
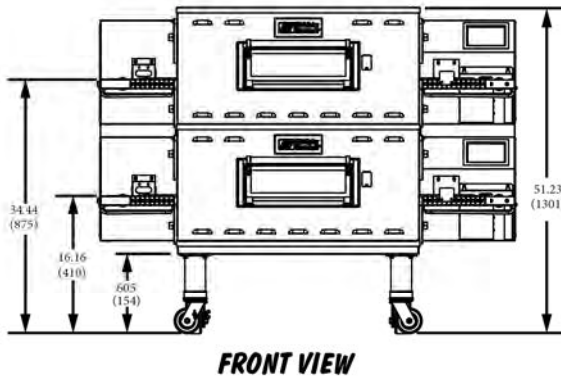

PS638-3 Triple Oven

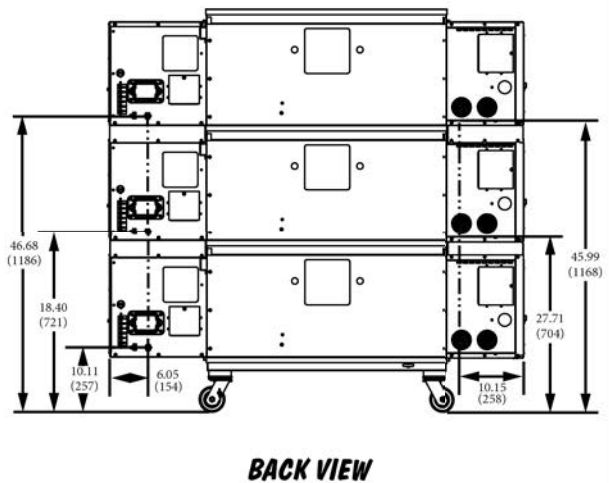
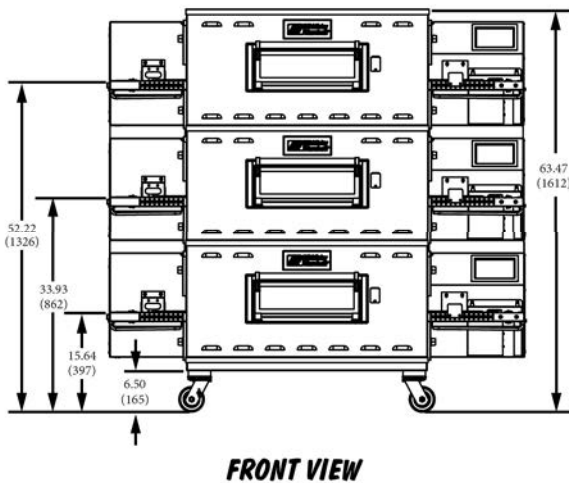

IV. VENTILATION SYSTEM

IMPORTANT

Where national or local codes require the installation of fire suppression equipment or other supplementary equipment, **DO NOT** mount the equipment directly to the oven.

MOUNTING SUCH EQUIPMENT ON THE OVEN MAY:

- VOID AGENCY CERTIFICATIONS
- RESTRICT SERVICE ACCESS
- LEAD TO INCREASED SERVICE EXPENSES FOR THE OWNER

A. Requirements

CAUTION: Gas oven installations REQUIRE a mechanically driven ventilation system with electrical air sensing control.

A mechanically driven ventilation system is **STRONGLY RECOMMENDED** for electric oven installations.

PROPER VENTILATION OF THE OVEN IS THE RESPONSIBILITY OF THE OWNER.

B. Recommendations

NOTE THAT THE HOOD DIMENSIONS SHOWN IN FIGURE 2-5 ARE RECOMMENDATIONS ONLY. LOCAL, NATIONAL, AND INTERNATIONAL CODES MUST BE FOLLOWED WHEN INSTALLING THE VENTILATION SYSTEM. ANY APPLICABLE CODES SUPERSEDE THE RECOMMENDATIONS SHOWN IN THIS MANUAL. IN AUSTRALIA, COMPLIANCE TO REGULATIONS AS/NZS 5601 IS MANDATORY.

The rate of air flow exhausted through the ventilation system may vary depending upon the oven configuration and hood design. Consult the hood manufacturer or ventilation engineer for these specifications.

To avoid negative pressure condition in the kitchen area, return air must be brought back to replenish the air that was exhausted. A negative pressure in the kitchen can cause heat related problems to the oven components as if there was no ventilation at all. The best method of supplying return air is through the heating, ventilation and air conditioning (HVAC) systems. Through the HVAC system, the air can be temperature-controlled for summer and winter. Return air can also be brought in directly from outside the building, but detrimental effects can result from extreme seasonal hot and cold temperatures from the outdoors.

NOTE: Return air from the mechanically driven system must not blow at the opening of the baking chamber. Poor oven baking performance will result.

C. Other Ventilation Concerns

1. Special locations, conditions, or problems may require the services of a ventilation engineer or specialist.
2. Inadequate ventilation can inhibit oven performance.
3. It is recommended that the ventilation system and ductwork be checked at prevailing intervals as specified by the hood manufacturer and/or HVAC engineer or specialist.

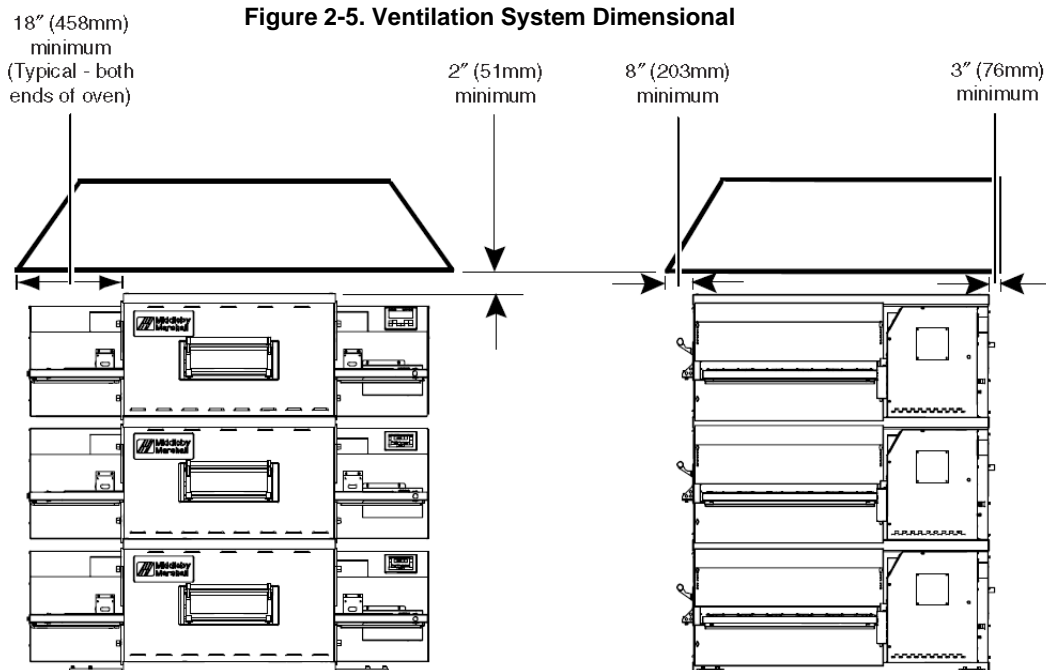

V. ASSEMBLY

A. Top Panel and Base Pad Assembly

1. Install the four leg extensions onto the base pad using the 3/8"-16 x 1" screws, 3/8" flat washers and 3/8" lock washers supplied in the Base Pad Kit. See Figure 2-6. Install the spring clip for the oven restraining cable to the hole in the bottom middle of the base pad, see Oven Base & Top Kit drawings (pages 5-7). This clip will attach to the restraint cable that keeps the oven from moving too far when installed on casters.
2. Install one caster or one adjustable 6" leg onto each leg extension and tighten securely in place.
3. Install the lower oven cavity onto the base pad. See Figure 2-7.
4. For single ovens ONLY:

Install the top panel using the screws included in the Base Pad Kit, as shown in Figure 2-8. Then, skip ahead to Part C, Restraint Cable Installation.

For double or triple ovens:

Continue to Part B, Stacking. Note that the top panel should NOT be installed for double and triple ovens until after stacking the oven cavities.

Fig 2-6. Leg Extension and Caster Installation

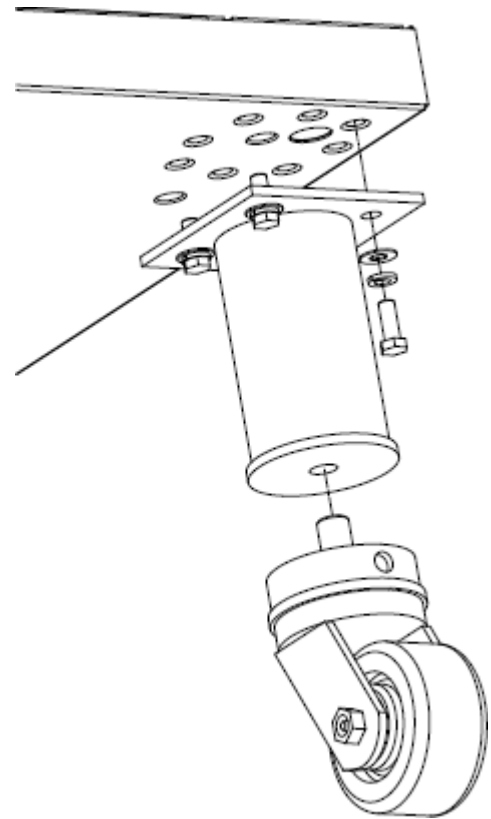

Figure 2-7. Base Pad Installation

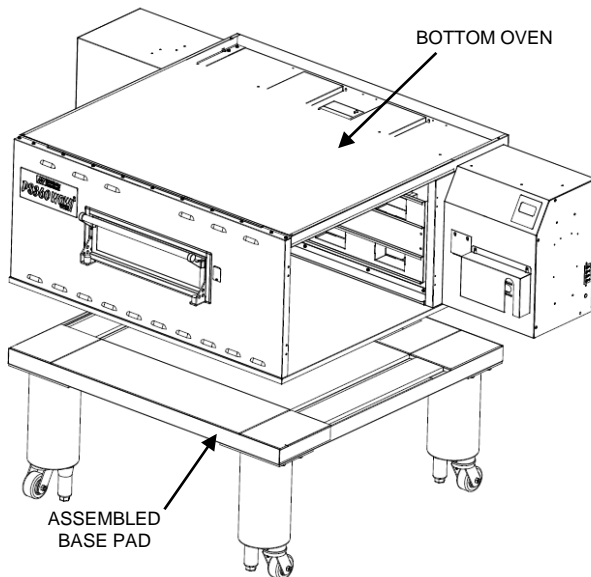
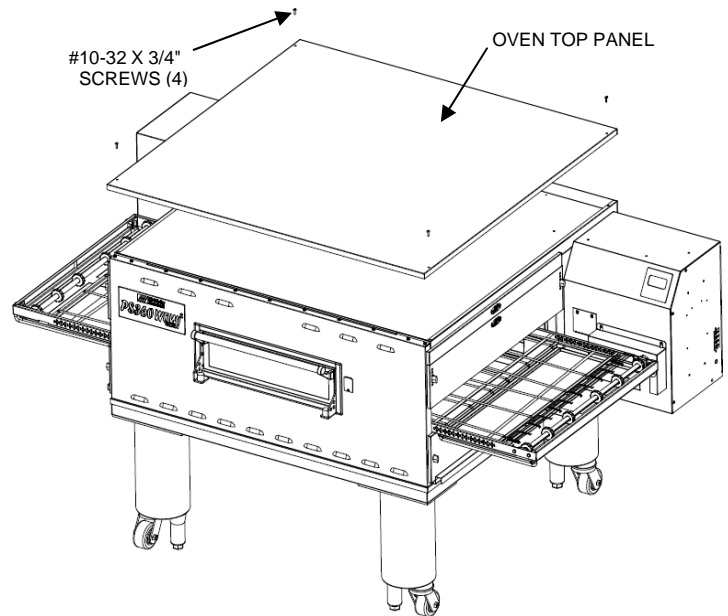

Figure 2-8. Top Panel Installation



NOTE: DO NOT install top panel onto double or triple ovens until AFTER stacking the oven cavities. See Part B, Stacking.

B. Stacking

For single ovens, skip ahead to Part C, Restraint Cable Installation.

IMPORTANT

Middleby Marshall **STRONGLY RECOMMENDS** that the PS638-WOW oven cavities be stacked by **AUTHORIZED PERSONNEL**.

Contact your Middleby Marshall Authorized Service Company for complete stacking instructions.

1. Stack an oven cavity on top of the lower oven. Check the following:
 - Insulation is installed on the lower oven top.
 - All four sides of the lower lip (on the bottom edge of the oven cavity) overlap the top of the lower oven.
 - The oven is level.
 - The oven is firmly seated, and the top insulation layer is installed smoothly and fully covering the metal panel. See Figure 2-9.
2. For triple ovens, repeat Step 1 to install the top oven cavity.
3. Install the top panel using the screws included in the base pad kit, as shown in Figure 2-10.

C. Restraint Cable Installation

Because the oven is equipped with casters, a restraint cable assembly must be installed to limit the movement of the appliance without depending upon the connector and the quick disconnect device or its associated piping. One end of the cable is anchored to the snap clip on the underside of the base pad while the other is anchored to the wall. See Figure 2-11.

After connecting the restraint cable, move the oven to its final location. Lock the two front casters.

The restraint cable is connected to the spring snap located at the back-center of the base underside. The 3/4" eyebolt must be anchored to the wall or floor to attach the other end of the restraint cable.

Figure 2-10. Top Panel Installation

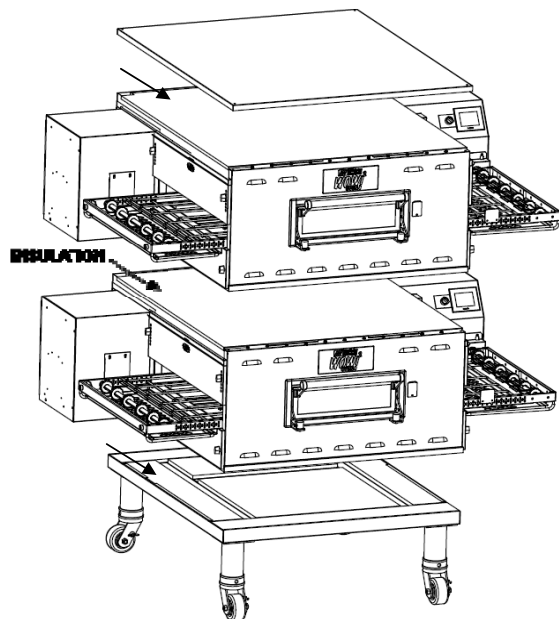

Figure 2-9. Stacking

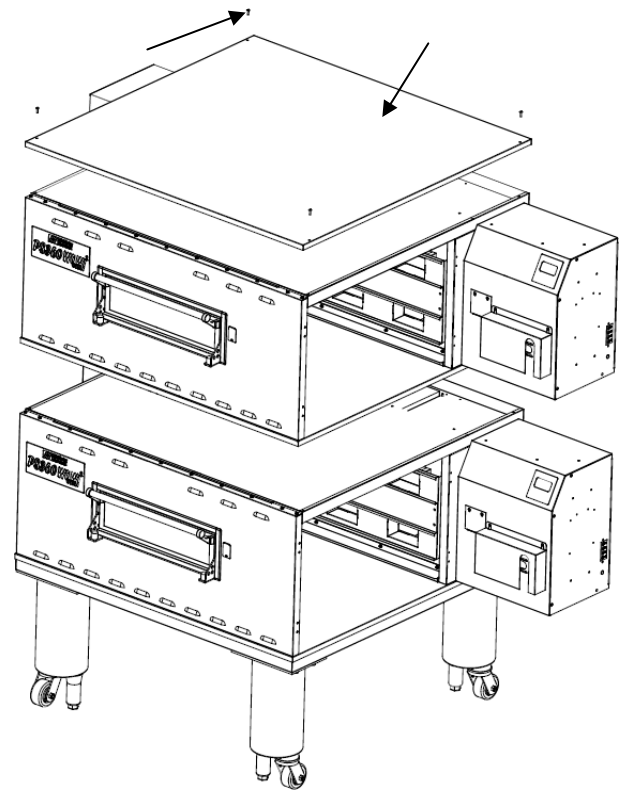
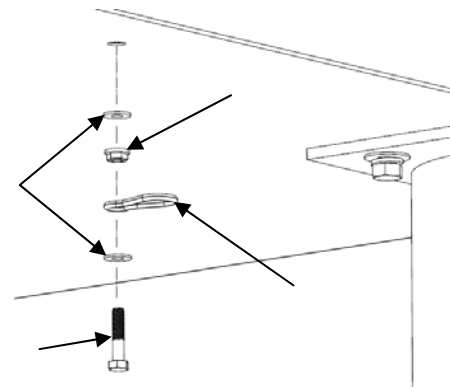

Figure 2-11. Installing the Restraint Cable



D. Conveyor Installation

1. Unfold the conveyor as shown in Figure 2-12. Then begin to slide the conveyor into the end of the oven. The conveyor can only be installed from the side of the oven where the drive motors are located.
2. Continue moving the conveyor into the oven until the frame protrudes equally from each end of the oven. Check that the crumb tray supports located on the underside of the conveyor frame rest firmly against the lower end plugs, as shown in Figure 2-13.
3. When the conveyor is positioned properly, check for freedom of movement of the conveyor belt by pulling it for about 2 to 3 feet (0.6 to 1.0 m) with your fingers. The drive and idler shafts must rotate smoothly, and the belt must move freely without rubbing on the inside of the oven. If not, then re-align the belting.
4. Check the tension of the conveyor belt as shown in Figure 2-14. The belt should lift about 1" (25 mm). **DO NOT OVER TIGHTEN THE CONVEYOR BELT.**

NOTE: If necessary, the belt tension can be adjusted by turning the conveyor adjustment screws, located at the idler (non-control) end of the conveyor. See Figure 2-14.

Figure 2-12. Conveyor Installation

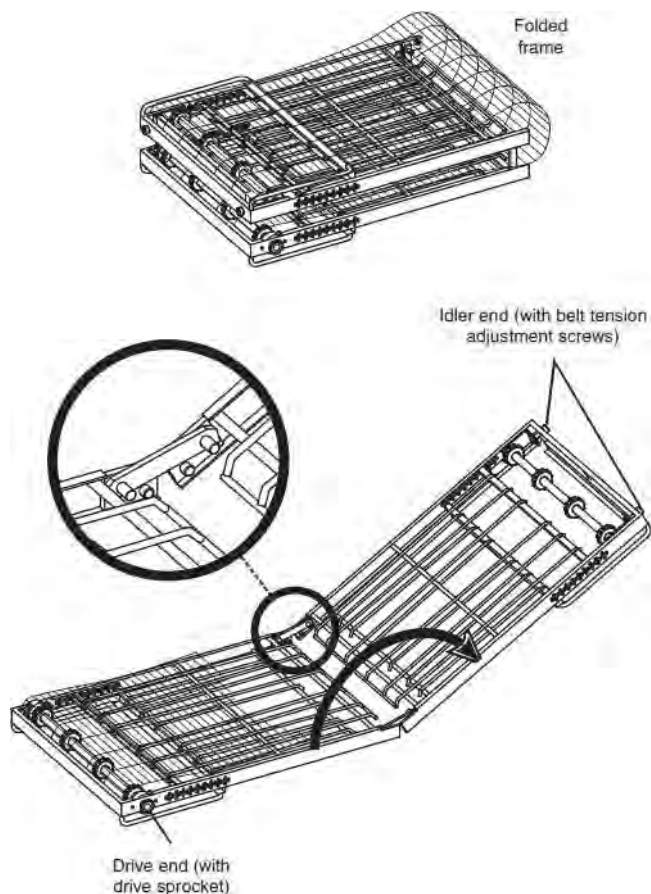

Figure 2-13

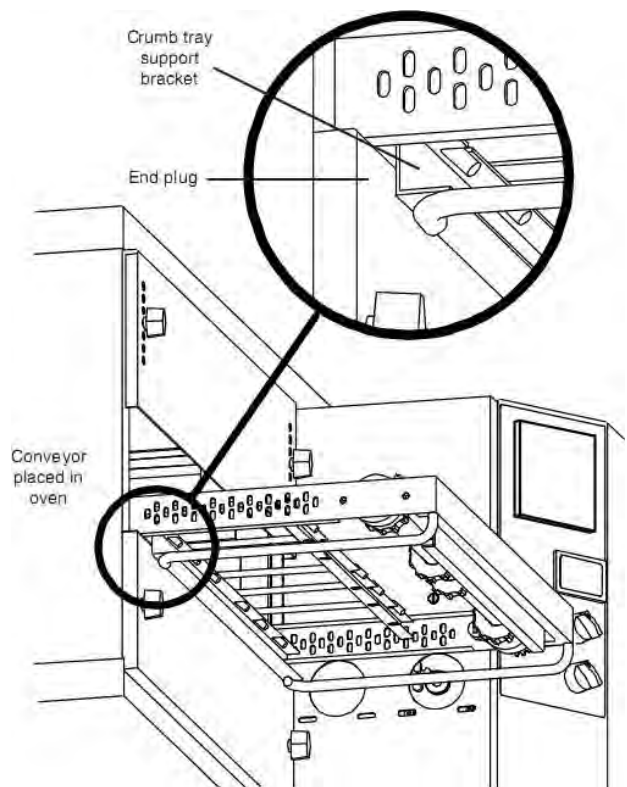
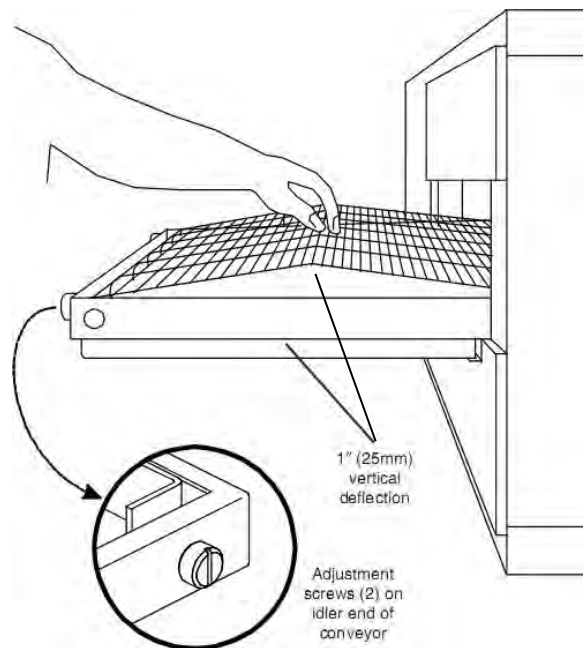
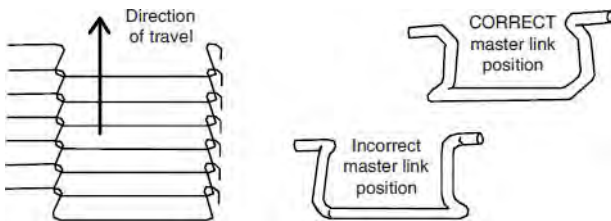

Figure 2-14. Conveyor Belt Tension



5. If it is necessary to add or remove conveyor links to achieve the correct tension, OR if it is necessary to reverse the conveyor belt for correct orientation, the belt will need to be removed from the conveyor frame. If this is necessary, perform the following procedure:
 - Remove the conveyor assembly from the oven and place it flat on the floor.
 - Remove the master links using long-nose pliers. Then, roll up the belt along the length of the conveyor frame.
 - Add or remove belt links as necessary to achieve the correct belt tension.
 - Replace the belt on the conveyor frame. Check that the conveyor belt links are oriented as shown in Figure 2-15, and that the smooth side of the conveyor belt faces UP.
 - Connect the inside master links. Check that the links are oriented as shown in Figure 2-15.
 - Connect the outside master links. Note that the outside master links each have an open hook on one side. This hook aligns with the hooks along the sides of the other conveyor links. See Figure 2-15.
 - Replace the conveyor into the oven.

Figure 2-15. Conveyor and Master Link orientation



E. Final Assembly

1. Install the crumb trays underneath the conveyor as shown in Figure 2-16.

Figure 2-16. Crumb Trays

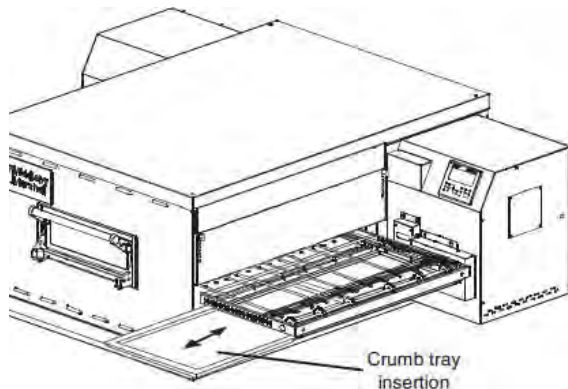

CAUTION:



Shock hazard in compartment's electrical filters is electrically alive.

VI. ELECTRICAL SUPPLY

CAUTION:



Authorized Installation Personnel normally accomplish the connections for the ventilation system, electric supply, and gas supply, as arranged by the customer. Following these connections, the Factory-Authorized Installer can perform the initial startup of the oven.

NOTE: The electric supply installation must satisfy the requirements of the appropriate statutory authority such as the National Electrical Code, CSA C22.2; the Australian Code AG601; or other applicable regulations.

NOTE: The electric supply connection must meet all national and local electrical code requirements.

Figure 2-17. Utility Connections Locations for Electrically Heated Oven

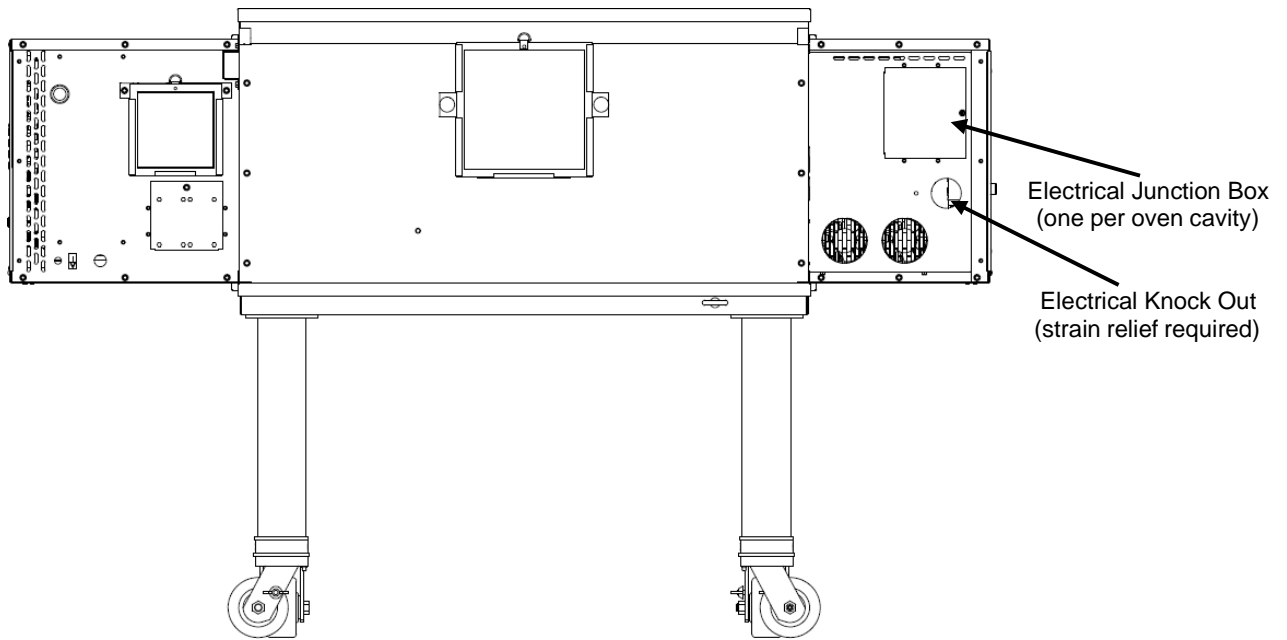

Check the oven serial plate before making any electric supply connections. Electric supply connections must agree with data on the oven serial plate. The location of the serial plate is shown in Figure 1-1 (in Section 1, Description).

A fused disconnect switch or a main circuit breaker (customer furnished) **MUST** be installed in the electric supply line for each oven cavity. It is recommended that the switch/circuit breaker have Lockout/Tagout capability.

The supply conductors must be of the size and material (copper) recommended. Refer to the wiring diagram inside the machinery compartment of the oven. Electrical specifications are also listed on the oven's serial plate and in Table 1-3, Electrical Specifications (in Section 1, Description).

The oven requires a ground connection to the oven ground screw. For gas ovens, the screw is located in the electrical junction box (see Figure 2-17). If necessary, have the electrician supply the ground wire. Do **NOT** use the wiring conduit or other piping for ground connections.

Incoming electrical power lines are fed through the strain-relief fitting, shown in Figure 2-17. The electrical supply connections are made inside the electrical junction box. The power lines then connect to the oven circuits through safety switches located inside the machinery compartment and each blower motor compartment. These switches interrupt electrical power to the oven when the Machinery Compartment Access Panel is opened, OR when the rear panel is removed.

Connection

Refer to the wiring diagram inside the machinery compartment of the oven to determine the correct connections for the electrical supply lines. Connect the supply as indicated on the wiring diagram.

CAUTION: *The terms of the oven's warranty require all start-ups, conversions and service work to be performed by a Middleby Marshall Authorized Service Company.*



Power requirements for electrically heated ovens are usually 208-240 VAC, 3-phase, 4-wire (3 hot, 1 ground), although ovens built for export can have power requirements of 380 VAC and 480 VAC. (These ovens have a 5-wire system.) A 2" (51 mm) diameter cutout/hole in the back of the machinery compartment provides access for the electrical supply connections. Using flexible cable(s) for the electrical power supply conductors requires a 2" (51 mm) strain-relief fitting (not furnished) to enable safe access to the terminal block from which oven power is distributed.

The supply conductors must be of the size and material (copper) recommended to provide the current required; (refer to the data plate for the ampere specifications). The electric current rating for each conductor supplying a PS640E-Series Oven must comply to local and national codes.

Typical specifications for each PS638E-Series Oven are 208V or 240V, 3-phase, 4-wire, 60-ampere, 34.4 kW. A PS638E Series Double Oven installation would require two 60-ampere service connections, one for each oven; the 34.4 kW power consumption also doubles for such an installation to 68.8 kW.

The 208V or 240 VAC electrically heated oven uses two legs of the supplied power to provide 208V or 240 VAC power for the oven control circuitry.

ELECTRIC SUPPLY TO BE PROVIDED BY CUSTOMER

WARNING
DO NOT USE CONDUIT FOR GROUND CONNECTION.

CAUTION
IT IS RECOMMENDED THAT THE OVEN BE PLACED UNDER A VENTILATION HOOD FOR ADEQUATE AIR SUPPLY AND VENTILATION.

ELECTRIC SUPPLY TO BE PROVIDED BY CUSTOMER

CIRCUIT BREAKER

Separate circuit breaker with lockout/tagout electrical shutoff for each oven. Wire each oven separately. 80 Amp circuit breaker for 208 / 70 Amp circuit breaker for 240V, or 50 Amp circuit breaker for 380-480V.

ELECTRICAL SPECIFICATIONS

DOMESTIC: 208V main blower motors and elements, 3 Phase, 63 Amp draw, 50/60 Hz, 208-240V control circuit, 3 pole, 4 wire system per oven (3 hot, 1 ground).

Do NOT use conduit for ground.

-or-

2. **DOMESTIC:** 240V main blower motors and elements, 3 Phase, 54 Amp draw, 50/60 Hz, 208-240V control circuit, 3 pole, 4 wire system per oven (3 hot, 1 ground).

Do NOT use conduit for ground.

-or-

EXPORT: 20.25 kW 380V elements, 3 Phase, 38 Amp draw, 50/60 Hz, 208-240V control circuit and main blower motor, 4 pole, 5 wire system per oven (3 hot, 1 neutral, 1 ground).

Do NOT use conduit for ground.

-or-

EXPORT: 18 kW 380V elements, 3 Phase, 37.4 Amp draw, 50/60 Hz, 208-240V control circuit and main blower motor, 4 pole, 5 wire system per oven (3 hot, 1 neutral, 1 ground).

Do NOT use conduit for ground.

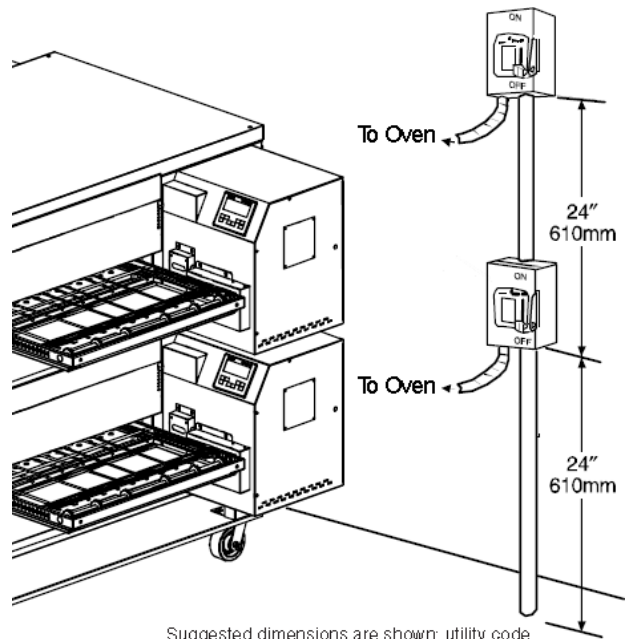

Suggested dimensions are shown; utility code requirements supersede any factors shown.

Typical PS638-Series Oven Installation

ELECTRICAL RATING

22.0 kW/hr for 208/240V

20.25 kW/hr for 380V

18 kW/hr for 380V

SUPPLY WIRE

Supply wire size must be in accordance with the National Electrical Code (current edition) and must be in compliance with local codes.

NOTE: The electrical terminal connection marked "MP" located inside the control compartment is designated for the blue (neutral) wire to the oven. See the electrical wiring diagram/schematics in Section 5 of this manual.

SUGGESTED

If space permits, service should be located near the control console end of the oven(s) to allow convenient access to safety switches.

Figure 2-17. Utility Connection Locations for Gas Ovens

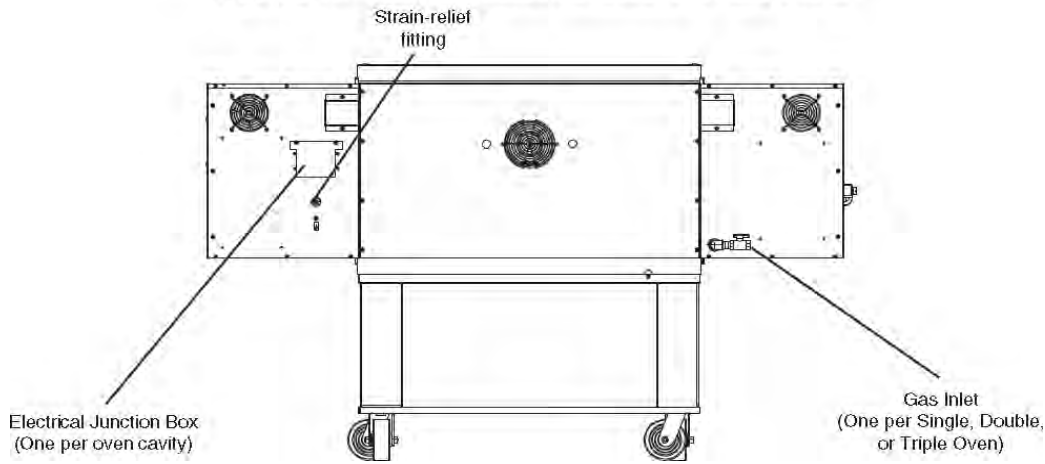

VII. GAS SUPPLY

CAUTION: DURING PRESSURE TESTING NOTE ALL OF THE FOLLOWING:



1. The oven and its individual shutoff valve must be disconnected from the gas supply piping system during any pressure testing of that system at test pressure in excess of 1/2 psi (3.45 kPa).
2. The oven must be isolated from the gas supply piping system by closing its individual manual shutoff during any pressure testing of the gas supply piping system at test pressure equal to or less than 1/2 psi (3.45 kPa).
3. If incoming pressure is over 14" W.C. (35 mbar), a separate regulator **MUST** be installed in the line **BEFORE** the individual shutoff valve for the oven.

CAUTION: To prevent damage to the control valve regulator during initial turn-on of gas, it is very important to open the manual shutoff valve very slowly.



After the initial gas turn-on, the manual shutoff valve must remain open, except during pressure testing as outlined in the above steps or when necessary, during service maintenance.

A. Gas Utility Rough-In Recommendations

The following system specifications are **STRONGLY RECOMMENDED**. Deviating from these recommendations may affect the baking performance of the oven.

Gas Meter

- One or two cavities: 425 CFH meter
- Three oven cavities: 630 CFH meter

Gas Line

- **DEDICATED GAS LINE** from the gas meter to the oven
- 1-1/2" (38.1 mm) pipe for Natural gas
- 1-1/2" (38.1 mm) pipe for Propane gas
- Maximum length: 200' (61 m). Each 90° elbow equals seven additional feet (2.13 m) of pipe.

B. Connection

Check the oven's gas supply requirements before making the gas utility connections. Gas supply requirements are listed on the oven's serial plate and in Table 1-4. Gas Orifice and Pressure Specifications (in Section 1, Description).

Check the serial plate to determine the type of gas (Propane or Natural) to be used with the oven.

Refer to the instructions in the gas hose package (included in the Installation Kit) before connecting the gas line. One gas line connection method is shown in Figure 2-18; however, compliance with the applicable standards and regulations is mandatory.

Inlet and regulated gas pressure readings can be taken using a digital tube manometer at the tap location shown in Figure 2-19. Figure 2-19 shows the burner assembly and Figure 2-21 shows the gas valve.

NOTE: The installation must conform with local codes or in the absence of local codes, to the National Fuel Gas Code, ANSI Z223.1, latest edition.

Certain safety code requirements exist for the installation of gas ovens; refer to the beginning of Section 2 for a list of the installation standards. In addition, because the oven is equipped with casters, the gas line connection shall be made with a connector that complies with the Standard for Connectors for Movable Gas Appliances, ANSI Z21.69/CSA 6.16 (in U.S.A.), as well as a quick-disconnect device that complies with the Standard for Quick-Disconnect Devices for Use With Gas Fuel, ANSI Z21.41/CSA 6.9 (in U.S.A.).

C. Gas Conversion

Where permitted by local and national codes, it is possible to convert ovens from natural gas to propane or from propane to natural gas. Use the appropriate Middleby Gas Conversion Kit for the specific oven model.

CAUTION: The terms of the oven's warranty require all startups, conversions, and service work to be performed by a Middleby Authorized ServiceAgent.



D. PS638G Propane/ULPG Conversion

Three items must be changed to change the oven to operate on ULPG (See Addendum for ULPG Conversion Kit # 74072)

1. Replace main orifices.
2. Replace the by-pass orifice
3. Adjust main gas regulator.

Disconnect the manifold union closest to the main burner, and remove the manifold assembly (four screws). Slide out the manifold assembly (leaving the ignition and sense wires connected). Replace the main orifices on the manifold assemblies with the ULPG orifices, and replace the manifold assembly. Reconnect the union.

Loosen the by-pass tube fitting to replace the by-pass orifice, tighten the tube fitting with the ULPG orifice inside accordingly.

Remove the seal cap on the regulator and rotate the adjustment screw in the clockwise direction to increase the regulated pressure to 6" W.C. (1.49 kPa) at the manifold.

E. Adjusting the Maximum Pressure Setting

If maximum rate pressure needs adjustment, follow instruction in Section VIII. PS638G GAS SPECIFICATIONS

Figure 2-18. Flexible Gas Hose Installation

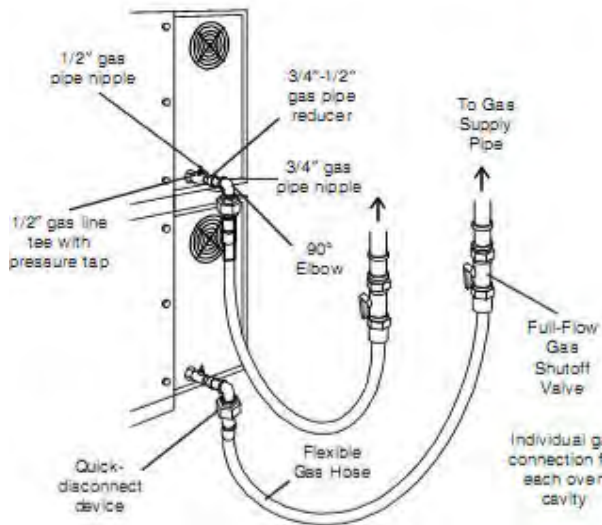

Figure 2-19. Gas Burner Assembly

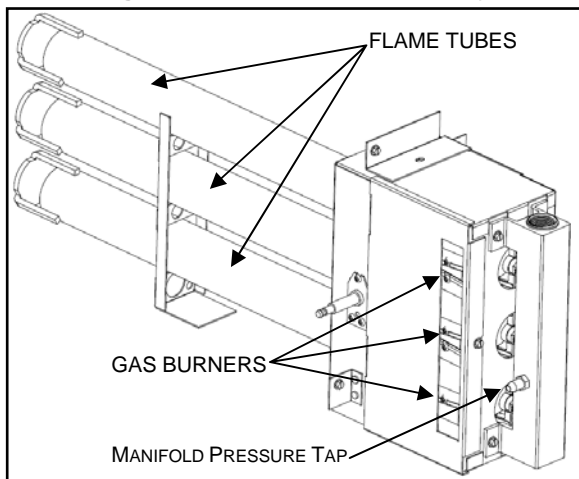
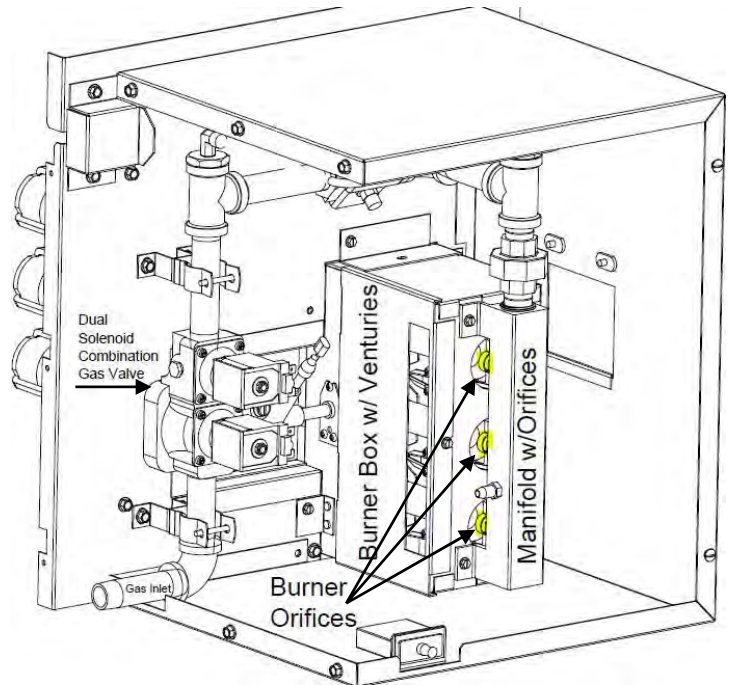

Figure 2-20. Burner Components



F. Checkout

After any adjustment, set appliance in operation and observe through a component cycle to ensure that burner system components function correctly.

NOTE: The installer **MUST** verify oven operation prior to putting oven into service.

G. Maintenance

It is recommended to check yearly the minimum and the maximum setting and readjust them if necessary.

H. Gas Train with Orificed By-Pass

For the Gas Trains that contain the Maxitrol Modulation Valve and a mushroom spud orifice inside the by-pass tube, no adjustments are required for the minimum pressure setting.

Figure 2-21. By-Pass Tube and Orifice Location

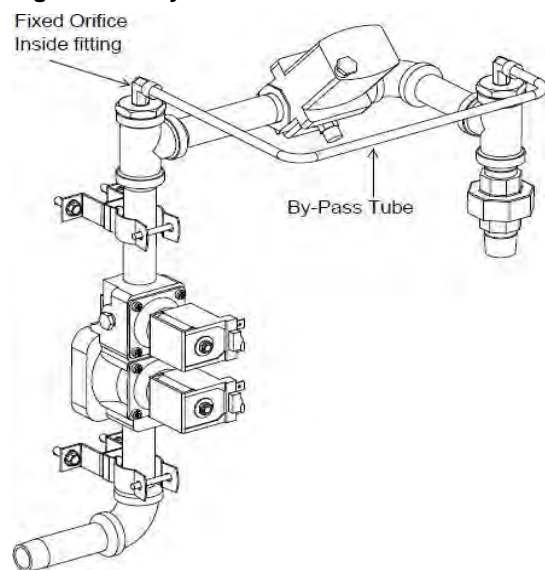

VIII. PS638G GAS SPECIFICATIONS

A. Natural Gas

Maximum Gas Input Rate: 89,000 BTU/Hr (26.1 kW) Incoming Gas Pressure Required: 6-8" W.C. (1.5 KPa-2.0 KPa) (14.9-19.9 mbar)

Burner Gas Manifold Pressure: 3.5" W.C. (0.87 KPa) (8.7 mbar)
Main Injector Size (3X): #39 drill (0.0995") (2.527 mm) / Marked #39 on injector
Bypass Injector Diameter: #49 drill (0.073") (1.854 mm)

B. Propane Gas

Maximum Gas Input Rate: 89,000 BTU/Hr (26.1 kW) Incoming Gas Pressure Required: 11-14" W.C. (2.7 KPa-3.5 KPa) (27.4-34.9 mbar)

Burner Gas Manifold Pressure: 6.0" W.C. (1.5 KPa) (14.9 mbar)
Main Injector Size (3X): 1.75 mm (0.0689") / Marked 1.75 on injector
Bypass Injector Diameter: #55 drill (0.052") (1.321 mm)

C. NATURAL GAS PRESSURE ADJUSTMENT [Factory Pre-Set]

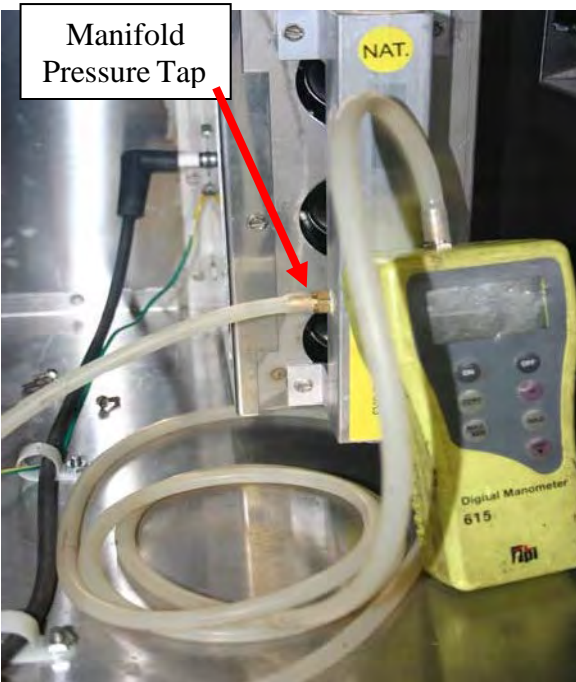

1. Turn the gas supply to the oven OFF. Open the tap screw in the MANIFOLD PRESSURE TAP fitting one full turn. Connect a silicone tube between the manifold pressure tap and a digital manometer. ZERO the digital manometer before performing the next step.
2. Locate the cap covering the pressure regulator adjusting screw on the combination gas control valve. Remove the cap to expose the pressure adjustment screw. Turn the gas to the oven on and start the oven.



Regulator Cap

3. Set the oven temperature to 550°F (288°C) and allow the oven to heat to 300°F (149°C). With the HEAT percentage on the user interface showing 100%, check the gas manifold pressure. For natural gas the pressure should read 3.5" W.C. (0.95 KPa, 8.7 mbar). To make any adjustments use either a 5/16" wide (7.9 mm) flat blade screwdriver or a T40 Torx bit is required.
4. If the measured gas pressure is higher than the required gas pressure setting, then turn the pressure adjustment screw counter-clockwise to decrease the gas pressure to the desired setting.
5. If the measured gas pressure is lower than the required gas pressure setting, then turn the gas pressure adjustment screw clockwise to increase the gas pressure to the desired setting.
6. Replace the cap removed in Step 2 back onto the combination gas control valve and tighten.
7. Turn the oven off. Turn off the gas supply to the oven. Remove the silicone tube from the manifold pressure tap. Turn the screw in the manifold pressure tap to the closed position. Make sure the screw is tightened securely. DO NOT OVER TIGHTEN.
8. Turn on the gas supply to the oven.
9. The oven is now ready for operation.

D. GAS CONVERSION

Where permitted by local and national codes, it is possible to convert ovens from natural gas to propane/ULPG or from ULPG to natural gas. Use the appropriate Middleby Gas Conversion Kit for the specific oven model.

CAUTION: The terms of the oven's warranty require all start-ups, conversions and service work to be performed by a Middleby Authorized Service Agent.

E. ULPG Orifice Conversion Procedure

1. Disconnect the gas supply to the oven.
2. Disconnect the manifold union closest to the gas burner manifold.
3. Remove the four screws securing the burner manifold assembly to the burner box (retain these screws they will be needed for reassembly).
4. Remove the burner manifold from the burner box.
5. Remove the existing main burner orifices and replace them with the main orifices supplied in the Middleby propane/ULPG kit. (1.75 mm)
6. Replace the burner manifold into the burner box and secure the burner manifold to the burner box with the four screws removed in Step 3 above.
7. Tighten the union connection that was loosened in Step 2 above.
8. (For Steps 8-11, See page 20, Figure 2-21: *ByPass Tube and Orifice Location drawing*)
9. Remove the two compression nuts on the 1/4" (6.35 mm) diameter aluminum tubing. Inside of the 1/4" (6.35 mm) diameter tubing (Located in the tee above the union) will be a small orifice.
10. Remove the by-pass orifice from the 1/4" (6.35 mm) diameter tube.
11. Insert the by-pass orifice from the Middleby propane conversion kit (#55 drill, 0.052" diameter, 1.321 mm) into the same position in the 1/4" (6.35 mm) diameter tube where the previous orifice was removed.
12. Reconnect the 1/4" (6.35 mm) tubing with the compression nuts that were removed in Step 8 above.

F. ULPG Pressure Adjustment

1. Locate the cap covering the pressure regulator adjusting screw on the combination gas control valve.
2. Remove the cap to expose the pressure adjustment screw.

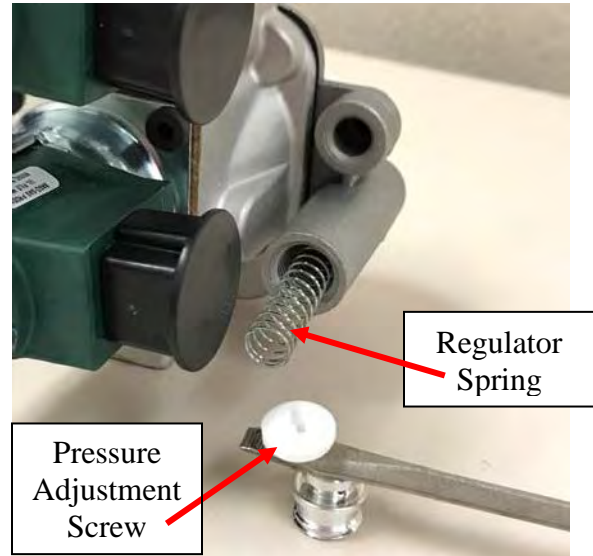

3. Using a 5/16" wide (7.9 mm) flat blade screwdriver (or a T40 Torx if available) remove the pressure adjuster screw by turning counter-clockwise.
4. If the measured gas pressure is higher than the required gas pressure setting, turn the pressure adjustment screw counter-clockwise to decrease the gas pressure to the desired setting.
5. If the measured gas pressure is lower than the required gas pressure setting, turn the gas pressure adjustment screw clockwise to increase the gas pressure to the desired setting.
6. Set the gas manifold pressure to 6" W.C. (1.5 kPa, 14.9 mbar) for Propane/ULPG.
7. Replace the cap removed in Step 2 back onto the combination gas control valve and tighten.
8. Turn the oven off. Turn off the gas supply to the oven. Remove the silicone tube from the manifold pressure tap. Turn the screw in the manifold pressure tap to the closed position. Make sure the screw is tightened securely. **DO NOT OVER TIGHTEN.**
9. Turn on the gas supply to the oven.
10. The oven is now ready for operation.

SECTION 3 – OPERATION

I. DESCRIPTION OF CONTROLS – User Interface

The PS638 oven control performs a variety of functions, including:

- Temperature control
- Belt speed control
- Blower speed setting
- Energy management
- Oven diagnostics and system testing
- Conveyor speed calibration (Service use only)

The oven control will have power delivered to it and initialize when the oven is connected to the power supply. Upon initialization, the control will display a splash screen consisting of a white background with MIDDLEBY MARSHALL text. The application will then load, showing the main off splash screen.

A. Standby/Splash Screen

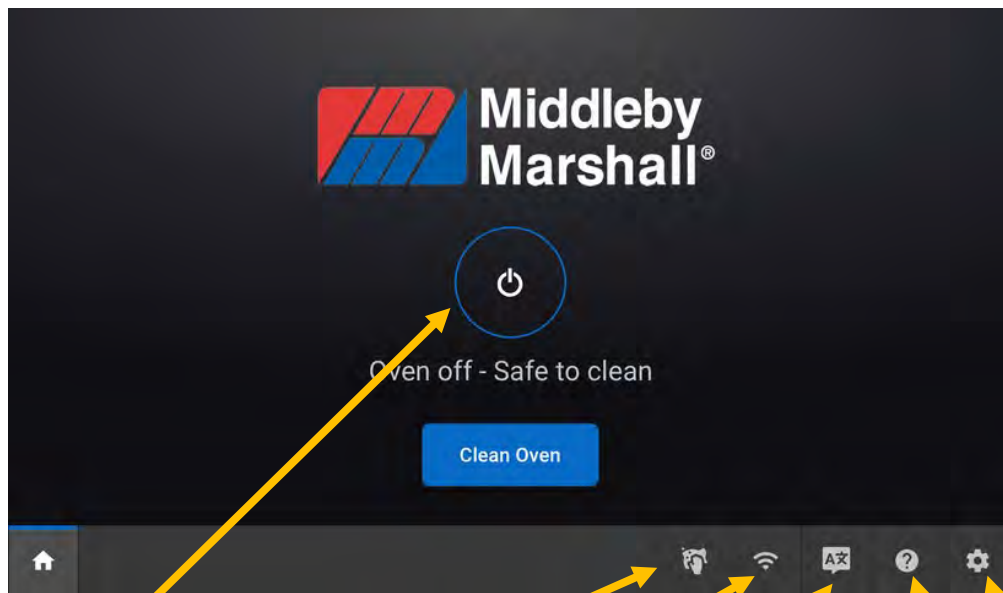

POWER BUTTON:

Press to initiate oven startup.

CLEAN SCREEN: Locks screen for 5 seconds to allow screen cleaning.

WIFI: Displays WiFi Status (if WiFi is connected).

LANGUAGE: Allows language selection (if enabled).

HELP: Shows help documents.

SETTINGS: Allows access to settings for Managers and Service Agents

B. Preheat Screen

Displays preheat status, allows access to oven settings by selecting PRESETS or MANUAL tab and shows preheat progress.

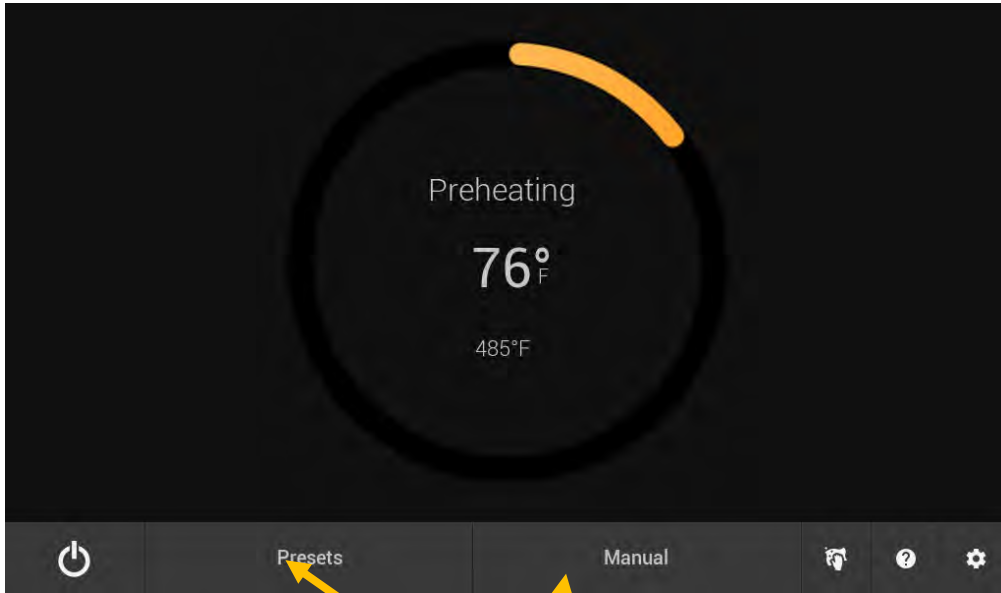

PRESETS: Press to switch to presets screen.

MANUAL: Press to switch to manual cooking screen.

C. Manual Cooking

In this screen you can change:

Temperature in 5 degree intervals between 300°F and 600°F

Belt times in 1 second intervals

When logged in as manager, blower speed by 1 percent intervals between 25% and 100%.

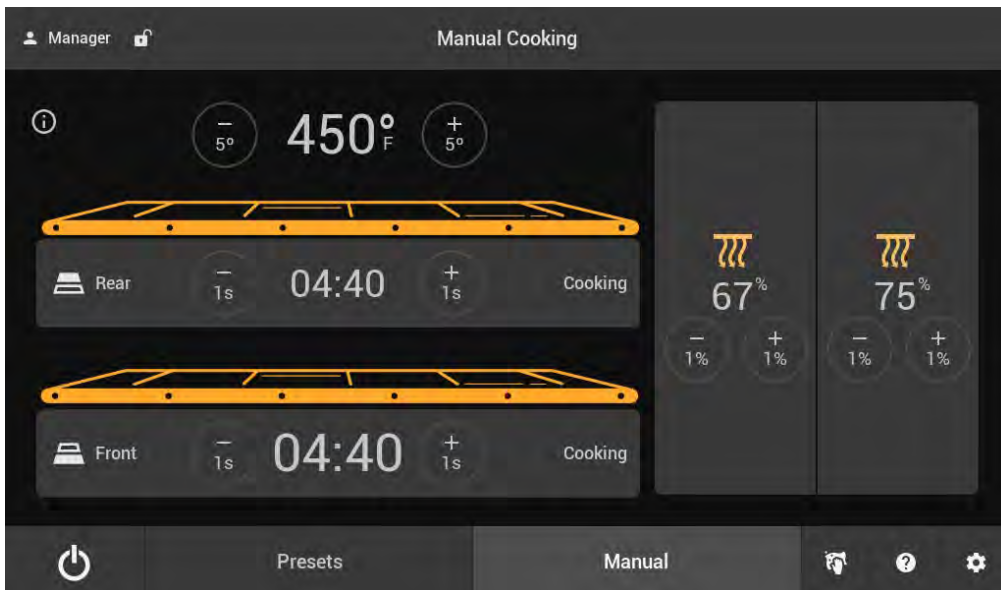

D. Preset Cooking

This screen allows the application of presets.

Presets may be created and edited by pressing the pencil icon in the top right of the screen. Alternatively, they may be accessed in the manager section of the settings screens.

Each preset contains three settings: Temperature, blower percentage, and a single belt time.

A preset must be applied to each belt in the oven. For single belt ovens, a single preset is applied. For split belt ovens, two presets must be applied, but the presets must have matching cavity settings (temperature and blower percent settings). The same preset can be applied to both belts.

To apply a preset to a belt, press the “plus” button above the desired belt and a list of available presets will be shown on the right side of the control. Presets that match the current cavity settings will be grouped together at the top of the list and shown in green. Other presets will also be grouped based on common cavity settings and will be shown in orange.

If a preset is selected that does not match the current cavity settings, a warning will appear on screen. You may either “Cancel” the selection or “Continue” to accept the new cavity settings. If the cavity settings are changed, any presets that are not compatible will be de-selected.

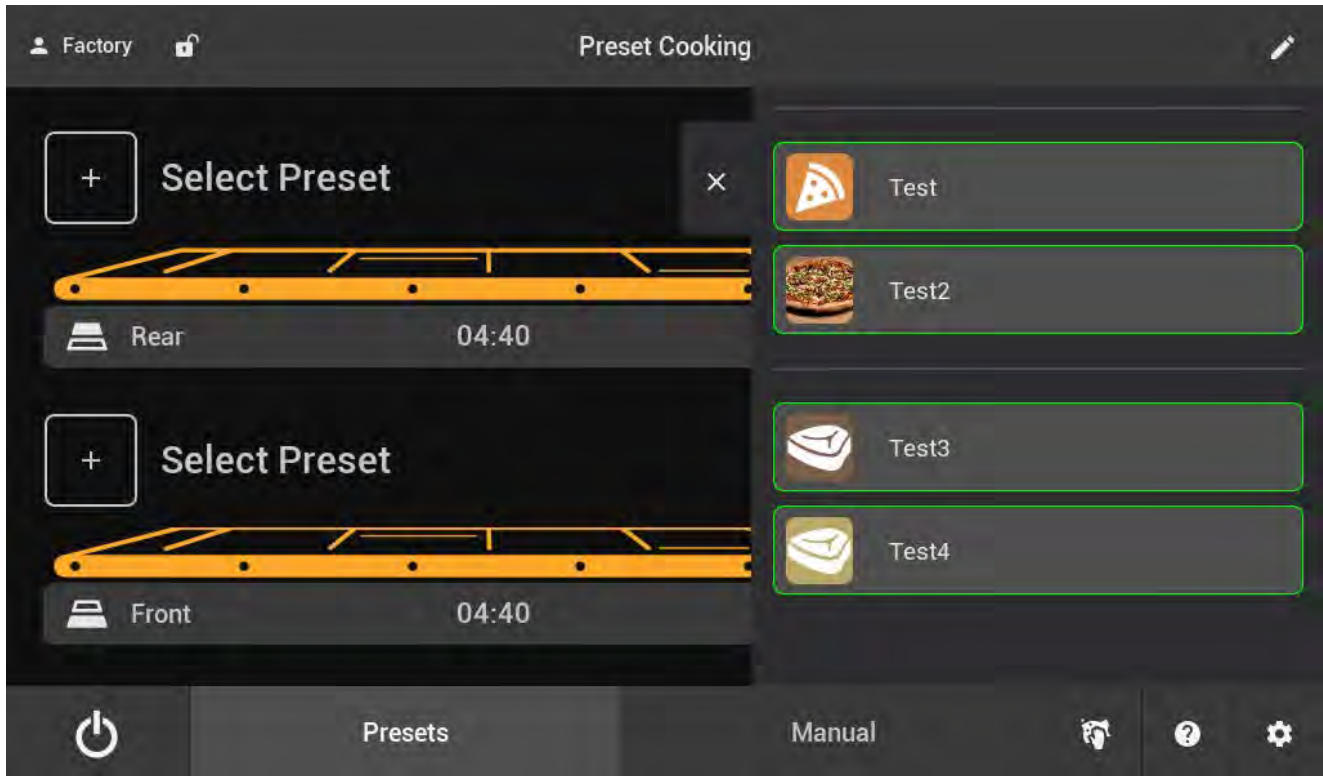

When selecting a preset, presets that match the current cavity settings will be at the top and outlined in green. Other presets will be highlighted in orange. Attempting to apply a preset that does not match the current cavity settings will show a warning. Accepting the warning will apply the preset and de-select the preset from the other belt. The user may switch to the manual screen and change settings, which will de-select the presets as well. Presets may be created and edited with the pencil icon, or in the manager section of the settings screens.

II. NORMAL OPERATION

A. Daily Start-up Procedure

To start the oven, press the power button. The display will transition to the preheat screen. The blower will begin and the blower proving switch will engage, permitting the heat circuit relay to engage. The gas ignition module will begin its cycle and ignite the burner.

B. Adjusting the Temperature – Manual Mode

To adjust the set temperature, press the “+5” or “-5” button next to the set temperature to adjust the temperature in five degree increments (in Celsius, the temperature increment is one degree). Larger adjustments can be made by pressing and holding the desired button.

C. Adjusting the Belt Time – Manual Mode

To adjust the belt time, press the “+1” or “-1” button next to the belt time to adjust the time in one second increments. Larger adjustments can be made by pressing and holding the desired button.

D. Adjusting Settings – Preset Mode

To adjust the oven settings, a preset must be applied to each belt. If there are no presets that match the desired oven settings, a preset must be created, or manual mode must be used.

E. Daily Shutdown Procedure (Turning the Oven Off)

To turn the oven OFF, press and hold the power button for ~1 second. This will bring up a confirmation dialogue. Press “Cancel” to return to the previous mode or press “Confirm” to proceed. If the oven is below 200°F cool down temperature, then the display will return to the STANDBY screen. If the oven is above 200°F, the display will show “COOLDOWN” and the blowers will run at a preset cool down speed until the oven temperature falls below 200°F at which point the oven will go to the STANDBY mode. If the sleep mode timer is enabled, the screen will enter sleep mode after a set period of time. In sleep mode, the screen will dim. The oven will stay in this condition until it is started again, with no outputs energized.

11. PROGRAMMING INSTRUCTIONS (MANAGER MODE)

A. Changing Baking Blower Speeds (Manual)

To change the ENTRANCE and/or EXIT blower speeds in manual mode:

1. Enter the SETTINGS page by pressing the gear icon in the bottom right corner of the screen.
2. Log in as manager (default passcode 8648) and return to the MANUAL screen.
3. The blowers will now have + and – buttons next to them. Press and hold the desired button until the desired blower speeds are set.

B. Changing Energy Mode Status

The photoeye operation can be overridden and baking mode can be continually engaged by disabling the energy mode. Energy use will be considerably higher without the energy saving mode.

Enter the SETTINGS screen and log in as manager. Under the “General” settings screen, scroll down to the “Photoeye Enabled” entry. Press the button to the right of the entry to disable the photoeye. The selector will change from green to grey.

C. System Setup

Additional system settings can be modified in the settings screen, accessed from the gear icon in the bottom right. Without logging in, only oven details are visible. After logging in as manager, there are four categories available: General, Belt Settings, Blower Settings, and Oven Details.

General Settings Options

- Audio Feedback Enabled: Enables audio feedback, especially for alerts.
- Beep on Button Press: Enables a beep when a button is pressed (audio feedback must be enabled).
- Language: Allows language selection.
- Language Icon View: Inserts a language icon in the bottom row that can be used to change the language.
- Display Brightness: Change the brightness of the screen.
- Date/Time: Set the date and time for improved oven monitoring.
- Sleep Mode Timer Enabled: Enables sleep mode (dimmed screen in Standby).
- Sleep Mode Timer: Change the amount of time the oven remains in Standby before sleep mode is enabled.
- Photoeye Enabled: Enables or disables the photoeye. If the photoeye is disabled, the blowers will run at “bake” speeds at all times.
- Photoeye Delay: Determines how long the photoeye must be broken before the bake mode is triggered.
- Temperature Units: Switch between Fahrenheit and Celsius.
- Operating Temperature: Allows restricting the operating temperature between the defaults of 300°F-600°F.
- Temperature Display Timeout: Determines how long “actuals” will be displayed when the info button is pressed. Set to “0” to disable actual temperature display.
- Manager Passcode: Allows the manager to customize the manager passcode.

Belt Settings Options

- Tweak Speed Percentage: Speed up or slow down the belt speed by up to 15% to fix small discrepancies in timing due to belt age

Blower Settings

- Blower Status: See blower speed (if rotation sensor equipped) and status of sensor (open/closed).
- Cooldown HZ: Set blower speeds during cooldown. Higher speeds produce more noise and use more power but cool down the oven faster.

Oven Details

- View oven details such as customer name, oven serial number, and software versions.

D. Energy Management Information

The PS638 oven reduces energy usage in two ways over most competitive ovens:

Modulating gas control (Energy Management System)

BAKING / IDLE mode control (Energy Saving Mode)

The modulating gas valve within the oven controls pressure of the delivered gas to the burners to increase or reduce the energy input as needed to maintain temperature instead of cycling a gas valve on and off. This is a most efficient and accurate way of controlling the temperature and eliminates the heat losses associated with the ON/OFF cycling control.

The PS638 oven, like other Middleby ovens, has an idle mode that places the blower at a reduced speed during non-baking periods. Reducing the blower speed reduces the volume of air requiring heating and thus reduces energy usage during these non-baking times. A photoeye sensor at the entrance side of the baking chamber detects when food is placed on the belt and brings the oven up to the higher (baking) blower speed, increasing the amount of convection / impingement air needed to cook products faster. When the product passes the photoeye, the controller begins a preset timed period that ensures the product will pass fully through the oven before the oven returns to the IDLE mode. With this energy management system, the oven provides the increased convection / impingement heat transfer into the products needed for fast, even baking, without the energy penalty during non-baking times. This functionality is fully automatic and requires no user interaction.

NOTES:

SECTION 4 - MAINTENANCE

WARNING

Before ANY cleaning or servicing of the oven, perform the following procedure:

1. Switch off the oven and allow it to cool. Do NOT service the oven while it is warm.
2. Turn off the electric supply circuit breaker(s) and disconnect the electric supply to the oven.
3. If it is necessary to move a gas oven for cleaning or servicing, disconnect the gas supply before moving the oven.

When all cleaning and servicing is complete:

1. If the oven was moved for servicing, return the oven to its original location.
2. If the restraint cable was disconnected to clean or service the oven, reconnect it at this time.
3. Reconnect the gas supply.
4. Reconnect the electrical supply.
5. Turn on the full-flow gas safety valve. Test the gas line connections for leaks using approved leak test substance or thick soap suds.
6. Turn on the electric supply circuit breaker(s).
7. Perform the normal startup procedure.

WARNING

Possibility of injury from moving parts and electrical shock exists in this oven. Switch off and lockout/tagout the electric supply BEFORE beginning to disassemble, clean, or service any oven. Never disassemble or clean an oven with the BLOWER switch or any other circuit of the oven switched on.

CAUTION

NEVER use a water hose or pressurized steam-cleaning equipment when cleaning this oven. To avoid saturating the oven insulation, DO NOT use excessive amounts of water. DO NOT use a caustic oven cleaner, which can damage the bake chamber surfaces.

NOTE

ANY replacement parts that require access to the interior of the oven may ONLY be replaced by a Middleby Marshall Authorized Service Agent. It is also strongly recommended that the 3-Month Maintenance and 6-Month Maintenance procedures in this section be performed ONLY by a Middleby Marshall Authorized Service Agent.

I. MAINTENANCE – DAILY

- A. Check that the oven is cool and the power is disconnected, as described in the warning at the beginning of this section.
- B. Clean ALL of the cooling fan grills and vent openings with a stiff nylon brush. Refer to Figure 4-1 for the location of the grills and vents.
- C. Clean the outside of the oven with a soft cloth and mild detergent.
- D. Check that all cooling fans are operating properly.

CAUTION:  If a cooling fan is not operating correctly, it must be replaced IMMEDIATELY. Operating the oven without adequate cooling can seriously damage the oven's internal components

- E. Clean the conveyor belts with a stiff nylon brush. This is more easily accomplished by allowing the conveyor to run while you stand at the exit end of the conveyor and brush the crumbs off the conveyor as it moves.
- F. Remove and clean the crumb trays. If necessary, refer to Figure 2-16 (in Section 2, Installation) when replacing the crumb trays into the oven.
- G. Clean the window in place.

Figure 4-1. Cooling Vents and Grills

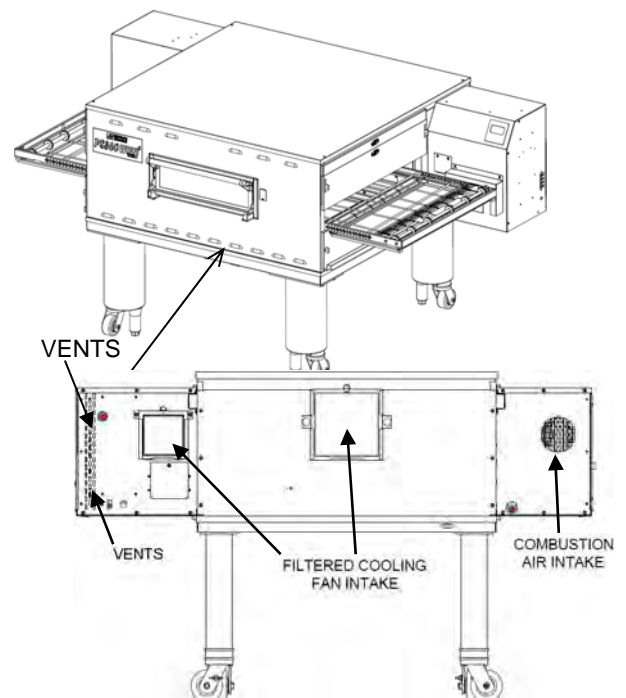

II. MAINTENANCE – MONTHLY

NOTE: When removing the conveyor, refer to Figure 2-12 (in Section 2, Installation).

- A. Check that the oven is cool and the power is disconnected as described in the warning at the beginning of this section.
- B. Remove the crumb trays from the oven.
- C. Lift the drive end of the conveyor slightly and push it forward into the oven. This removes the tension from the drive chain. Remove the drive chain from the conveyor sprocket.
- D. Slide the conveyor out of the oven, folding at as it is removed.
- E. Remove the end plugs from the oven. The end plugs are shown in Figure 1-1 (in Section 1, Description).
- F. Slide the air fingers and blank plates out of the oven, as shown in Figure 4-2. AS EACH FINGER OR PLATE IS REMOVED, WRITE A "LOCATION CODE" ON IT WITH A MARKER to make sure it can be reinstalled correctly.

Example of markings:

Top Row → **T1** **T2** **T3** **T4**
 Bottom Row → **B1** **B2** **B3** **B4**

- G. Disassemble the air fingers as shown in Figure 4-3. AS EACH FINGER IS DISASSEMBLED, WRITE THE "LOCATION CODE" FOR THE FINGER ON ALL THREE OF ITS PIECES. This will help to correctly reassemble the air fingers.

CAUTION: *Incorrect reassembly of the air fingers will change the baking properties of the oven.*



- H. Clean the air finger components and the interior of the baking chamber using a vacuum cleaner and a damp cloth. Refer to the boxed warnings at the beginning of this section for cleaning precautions.
- I. Reassemble the air fingers. Then replace them in the oven, using the "location codes" as a guide.
- J. Replace the end plugs on the oven.
- K. Reassemble the conveyor into the oven. If the drive sprocket was removed when installing the conveyor, replace it at this time.
- L. Reattach the drive chain.
- M. Check the tension of the conveyor belt as shown in Figure 2-14 (in Section 2, Installation). The belt should lift 1" (25.4 mm) DO NOT OVERTIGHTEN THE CONVEYOR BELT. If necessary, the belt tension can be adjusted by turning the conveyor adjustment screws, located at the idler (left) end of the conveyor
- N. Replace the crumb trays.

Figure 4-2. Removing Air Fingers and Plates

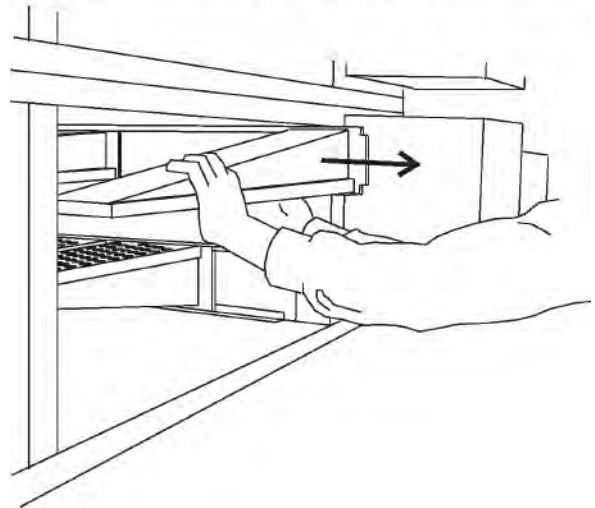
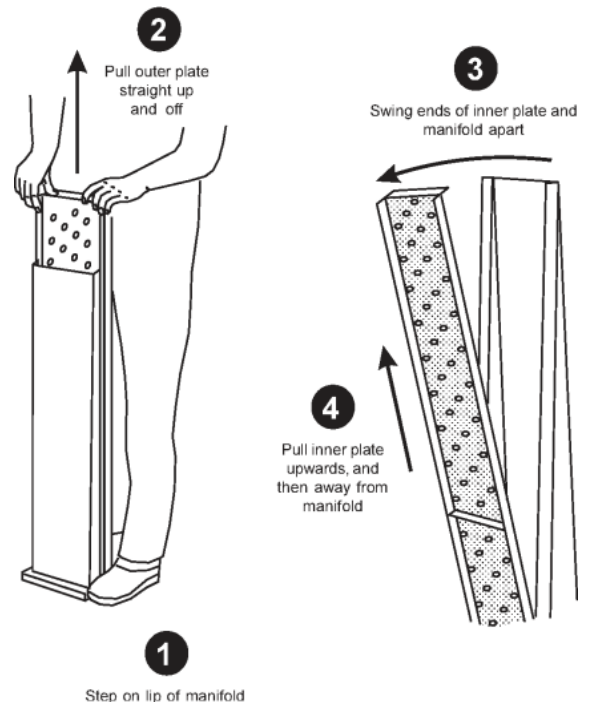
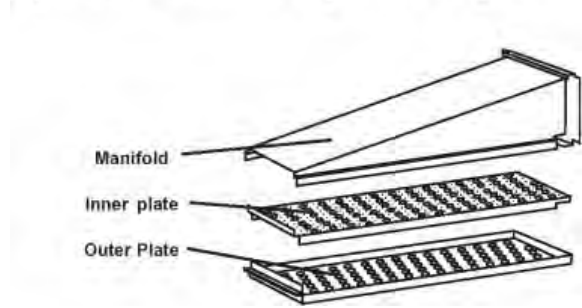

Figure 4-3. Disassembling the Air Fingers



III. MAINTENANCE – EVERY 6 MONTHS

- A. The Six-Month Maintenance should be carried out by a qualified Middleby authorized service agent or by Middleby authorized personnel.
- B. Check that the oven is cool and the power is disconnected, as described in the warning at the beginning of this section.
- C. For gas ovens, inspect and clean the burner nozzle and the spark electrode assembly.
- D. Vacuum all of the blower mounts and their surrounding compartments using a shop vacuum.
- E. Tighten all electrical terminal screws
- F. Check the conveyor drive shaft bushings and spacers. Replace the components if they are worn.
- G. Split Belt Disassembly and Cleaning
 1. Refer to Part D, Conveyor Installation, in the Installation section of this manual. Then, remove the following components from the oven:
 - Conveyor end stop
 - Crumb trays
 - Chain cover
 - Drive chains
 - End plugs
 - Conveyor assembly
 2. Remove the master links from each conveyor belt. Then, roll the belts up along the length of the conveyor to remove them from the frame.
 3. Remove the two conveyor adjustment screws from the idler end of the conveyor frame, as shown in Figure 4-4.
 4. Remove the idler shaft assembly from the conveyor.
 5. Pull apart the two sections of the idler shaft.
 6. Clean the shafts thoroughly using a rag. Lubricate both the extended shaft and the interior of the hollow shaft using a light food-grade lubricant. DO NOT lubricate the shafts using WD-40 or a similar product. This can cause the shafts to wear rapidly.
 7. Before reassembling the shafts into the conveyor frame, check that they are oriented properly.

8. Reassemble the idler shaft into the conveyor. Make sure that the bronze washer is in place between the two sections of the shaft. See Figure 4-4.
9. Replace the conveyor adjustment screws as shown in Figure 4-4. To allow the conveyor belt to be reinstalled later, do not tighten the screws at this time.
10. Loosen the set screw on both of the conveyor drive sprockets. Remove the sprockets from the shaft.
11. Check the conveyor configuration as follows:
High-speed conveyors are equipped with large flange bearings at both ends of the shaft, as shown in Figure 4-5. For these conveyors, remove the two screws that hold each bearing to the conveyor frame. With the screws removed, lift the end of the shaft at the front of the oven, and pull the entire assembly free of the conveyor frame.

Standard conveyors are equipped with bronze bushings mounted on spacers at both ends of the shaft, as shown in Figure 4-5. For these conveyors, remove the two screws that hold the bracket to the conveyor frame. With the screws removed, lift the end of the shaft at the front of the oven and pull the entire assembly free of the conveyor frame. The brackets will be removed along with the drive shaft assembly.

12. Disassemble and lubricate the two sections of the drive shaft as described for the idler shaft, Step 6.
13. Before reassembling the shafts into the conveyor frame, check that they are oriented properly.
14. Reassemble the drive shaft into the conveyor. Make sure that the bronze washer is in place between the two sections of the shaft. See Figure 4-6.
15. Replace the drive sprockets. Reassemble the belts and master links onto the conveyor.
16. Reinstall the end plugs and conveyor onto the oven. Reattach the drive chains. Replace the chain cover.
17. Check the tension of the conveyor belt as shown in Figure 2-14 (in Section 2, Installation). The belt should lift about 1" (25 mm). If necessary, adjust the belt tension by turning the conveyor adjustment screws.
18. Replace all components onto the oven.

Figure 4-4. Disassembling the Idler Shaft

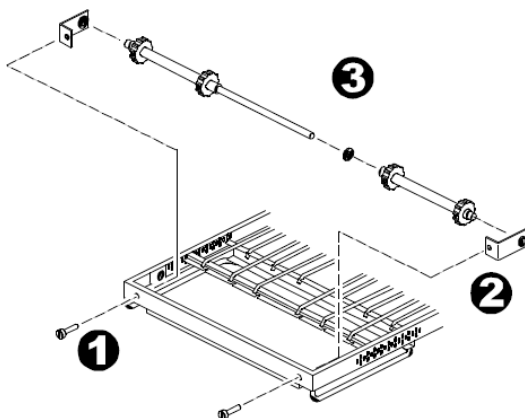

Figure 4-5. Drive Shaft Configurations

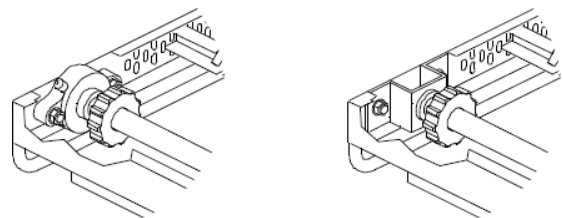
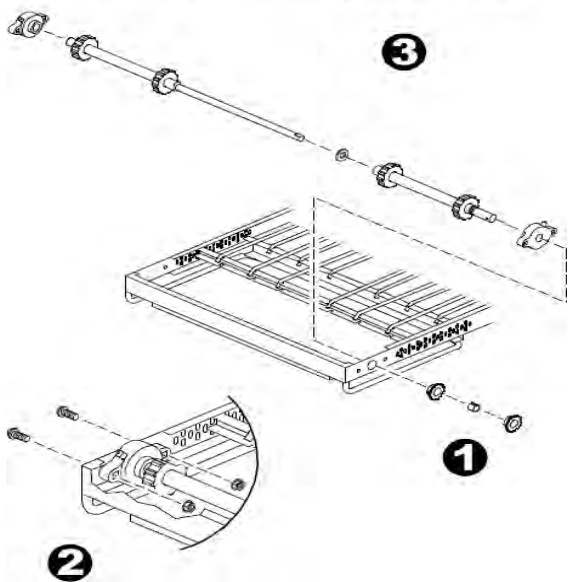

Figure 4-6. Disassembling the drive shaft



IV. VENTLESS OVEN CATALYST CARE

Catalytic Converter

The catalytic converter, a VOC type catalyst, is located inside the cooking cavity wall and is responsible for cleaning the recirculating airflow. The catalyst functions by substantially lowering the combustion temperature of grease entrained in the air path to approximately the same temperature of the airflow, thus the grease burns and breaks down into CO₂ and H₂O as it passes through the catalytic converter. The catalyst will operate most efficiently at temperatures above 475°F (246°C). The catalyst material is very sensitive to certain chemical compounds. Irreversible damage can occur if the catalyst is exposed to cleaning chemicals containing phosphates, NaOH, silicates, Na and Potassium Salts. These chemicals are found in most commercial degreasers and cleaners; therefore, only Middleby® Oven Cleaner should be used.

CAUTION: Use only Middleby-approved cleaning chemicals only from the Tested and Approved list here. Failure to adhere to these procedures or the use of any other non-approved cleaning products may damage critical oven components, resulting in a non-warranty service call.

Approved Cleaners and Chemicals

Due to the sensitivity of certain Middleby Marshall oven components, some cleaners and chemicals can damage the oven, resulting in down-time and costly repair. Please adhere to the lists below to determine which cleaners are appropriate to use when cleaning your Middleby Marshall oven. If a cleaner is not provided on either list below, then it is not recommended for use. However, you can submit the chemical to Middleby Marshall for evaluation and if it gains approval, it will be added to the list of approved cleaners.

Tested and Approved

The following cleaners and chemicals have been tested and approved by Middleby Marshall:

- Middleby Marshall Oven Cleaner
- Middleby Marshall Waveguide Cleaner
- Kay Oven Cleaner (specific title; approval does not apply to other Kay products)
- Kay Super Contact Cleaner
- Ecolab Hawk Fryer Cleaner
- Skal Generic Oven Cleaner (Simonize)
- SUBWAY Bread Oven Cleaner
- Chemco Oven Guard
- Chemco Dirt Buster III
- Ecolab Grease Lift
- SSDC Clinging Degreaser
- Ecolab Super Cling Degreaser
- Ecolab Greaselift RTU
- Apter Oven Safe

Investigated/Tested and Not Approved

The following cleaners and chemicals are not approved for use in Middleby Marshall ovens:

- Kay Titan HD Degreaser
- Kay Kote Soil Shield
- Drackett Mr. Muscle
- SC Johnson GP Forward
- Proctor & Gamble Dawn
- Reckitt Benckiser Easy-Off
- Obtain-Wise Ltd. Oven Cleaner
- Obtain-Wise Ltd. Oven Protector Skal
- General Oven Guard (Simonize) EcoLab
- Greasecutter Ecolab Grease Strip Plus
- Johnson Diversity Spectrum Plus

V. PS638E & G OVEN KEY SPARE PARTS

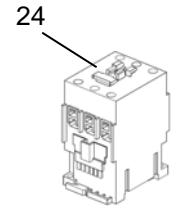
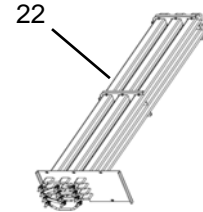
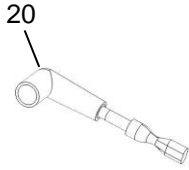
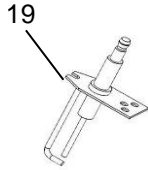
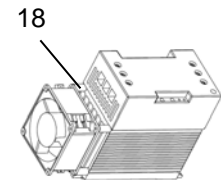
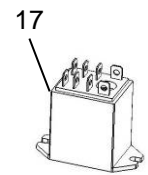
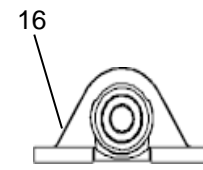
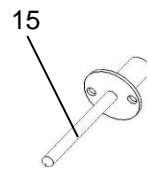
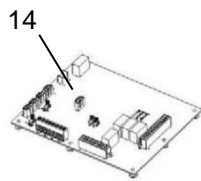
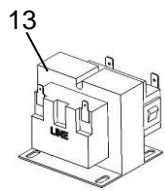
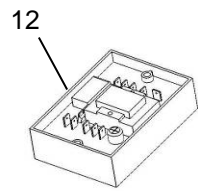
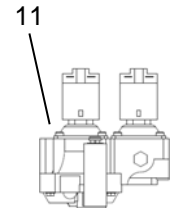
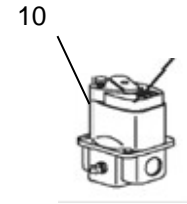
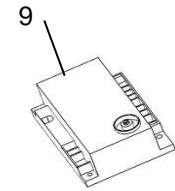
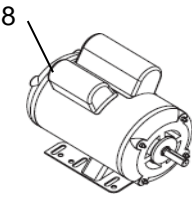
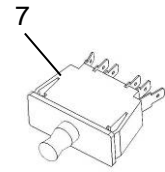
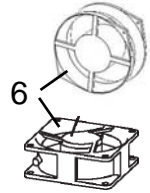
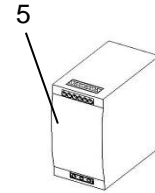
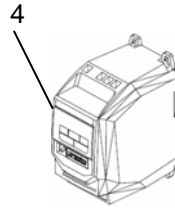
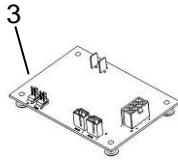
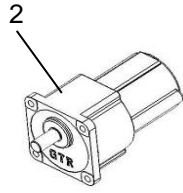
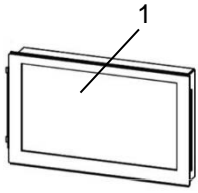

V. PS638E & G OVEN KEY SPARE PARTS

ITEM	QTY	P/N	DESCRIPTION
1	1	77507	Digital Display, Programmed
2	1	74106	Motor, Conveyor Drive (74106)
3	1	77277	Conveyor Control Board
4	1	74097	VFD Inverter, 2 HP (230 VAC Input)
5	1	76979	Power Supply, 24 VDC, 60W
6a	1	36451	Small Cooling Fan for Right Control Compartment
6b	1	97525	Large Cooling Fan for Center Rear of Oven
n/s	1	77174	Small Cooling Fan Filter (5" square)
n/s	1	77553	Large Cooling Fan Filter (6.5" square)
7	2	63909/63910	Door Switches, Interlock / Momentary
8	1	57288	Blower Motor, 2 HP
9	1	62285	Ignition Module (Gas Only)
10	1	59450	Maxitrol Modulating Gas Valve (Gas Only)
11	1	59465	Dual Solenoid Combination Valve (Gas Only)
12	1	33983	Hi Limit Thermostat
n/s	1	78814	High Limit Reset Button
13	1	32108	Transformer, 240 primary / 24 secondary
14a	1	77275	I/O Board
14b	1	77276	Relay Board
15	1	33984	Thermocouple (3 per oven)
16	1	64106	Bearing, Dodge 5/8
17	1	60952	Relay, DPDT 208-240 VAC Coil
18a	2	76289	208/240V SS Power Controllers
18b	1	76289	380/416V SS Power Controllers
19	1	71037	Single Rod Igniter
20	1	62282	Ignition Cable
n/s	2	71815	Blower Shaft
21	1	50517	Serpentine Blower Belt
22a	1	60750	Heater, 27 kW, 208 VAC Specific
22b	1	74125	Heater, 27 kW, 240 VAC Specific
22c	1	68661	Heater, 18 kW, 380 VAC Specific
22c	1	73656	Heater, 27 kW, 380 VAC Specific
23	1	72209	Photoeye (optional)
n/s	1	74316	Photoeye Lens (optional)
24	1	44549	Contactactor (Electric Only)

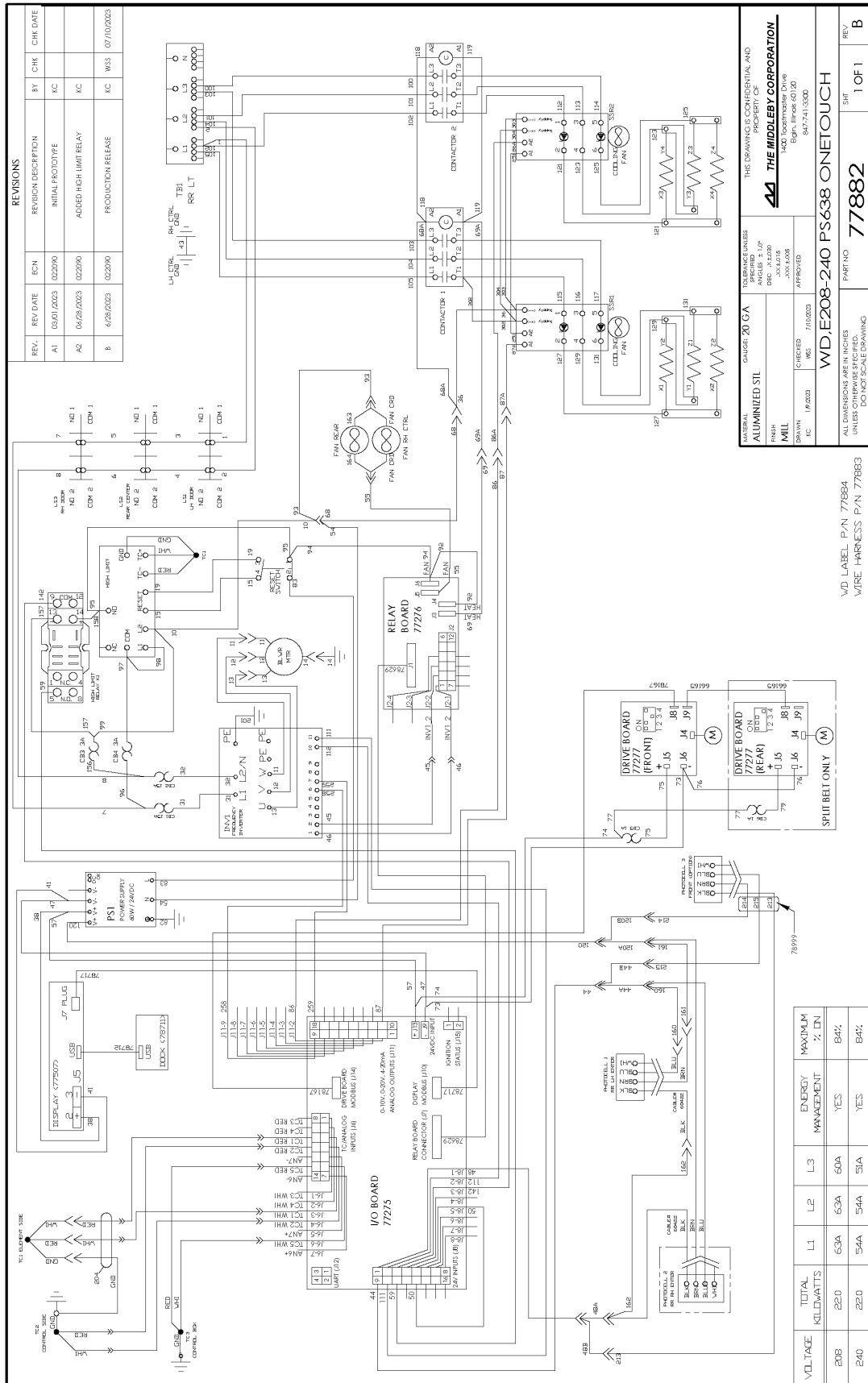

REVISIONS

REV#	REV DATE	REV DESCRIPTION	BY	CHK	CHK DATE
A1	03/01/2023	INITIAL PROTOTYPE	KC		
A2	06/29/2023	ADDED HIGH LIMIT RELAY	KC		
B	6/29/2023	PRODUCTION RELEASE	KC	WS3	07/10/2023

THIS DRAWING IS CONFIDENTIAL AND NOT BE LOANED, REPRODUCED, COPIED, OR DISSEMINATED WITHOUT THE WRITTEN PERMISSION OF THE MIDDLEY CORPORATION

THE MIDDLEY CORPORATION
847-741-3000

ALUMINIZED STL
GAGE: 20 GA
FINISH: MILL
DRAWN: J.P.2023
CHECKED: J.P.2023
APPROVED: J.P.2023

UNLESS OTHERWISE SPECIFIED, ANGLES: 1/16" ROUNDS: .005" DIA. DIMENSIONS ARE IN INCHES UNLESS OTHERWISE SPECIFIED. DO NOT SCALE DRAWING.

WD,E208-240 PS638 ONETOUCH
PART NO: 77882
SHEET: 1 OF 1
REV: B

VOLTAGE	TOTAL KILOWATTS	L1	L2	L3	ENERGY MANAGEMENT	MAXIMUM % ON
208	22.0	63A	63A	60A	YES	84%
240	22.0	54A	54A	51A	YES	84%

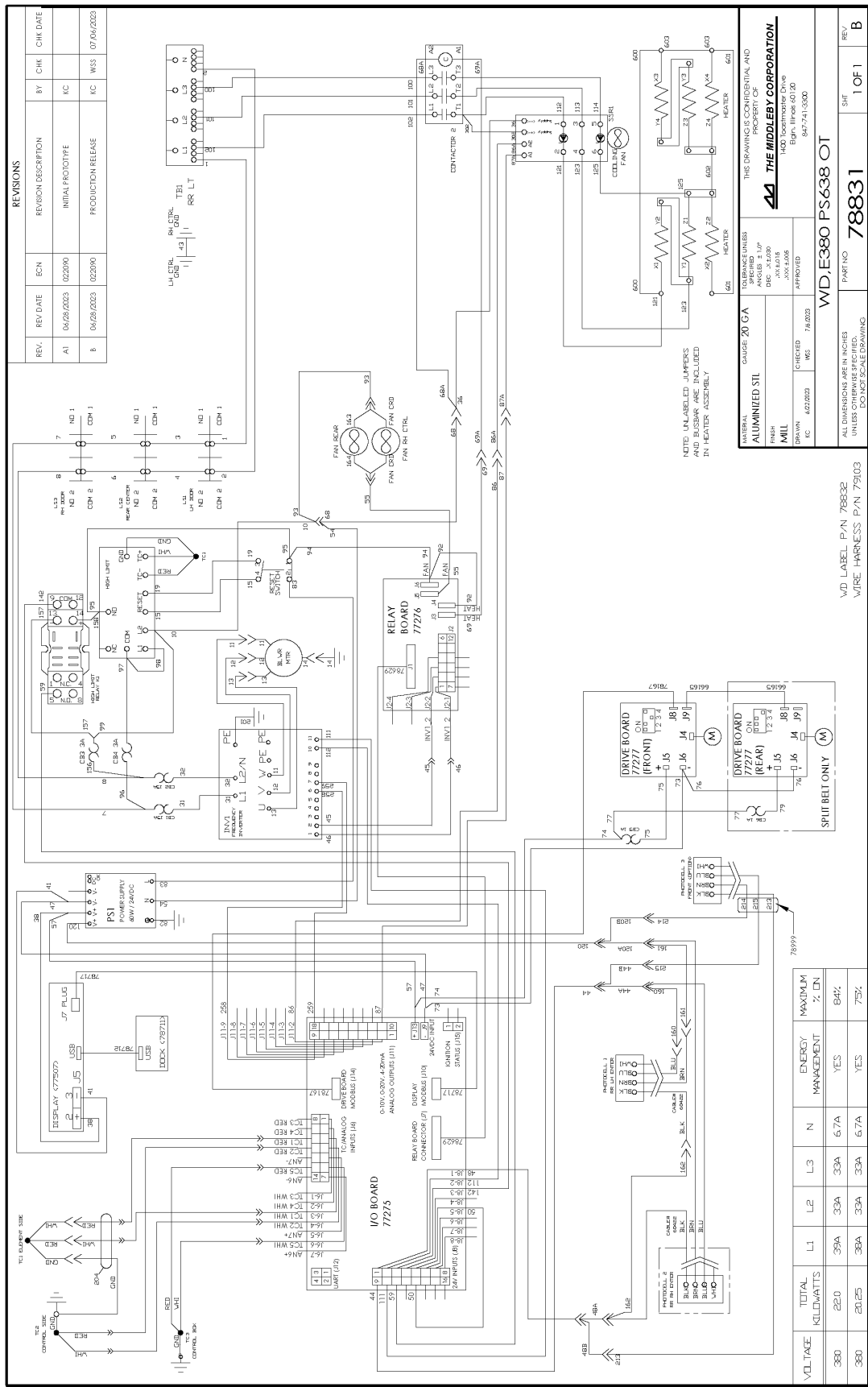

REVISIONS

REV.	REV. DATE	ECH	REVISION DESCRIPTION	BY	CHK	CHK DATE
A1	06/29/2023	022090	INITIAL PROTOTYPE	MC		
B	06/29/2023	022090	PRODUCTION RELEASE	MC	WSS	07/06/2023

THE DRAWING IS CONFIDENTIAL AND NOT BE LOANED, REPRODUCED, COPIED, OR DISSEMINATED IN ANY MANNER WITHOUT THE WRITTEN PERMISSION OF THE MIDDLEBURY CORPORATION.
THE MIDDLEBURY CORPORATION
 1000 MIDDLEBURY BLVD
 BRATTLEBORO, VT 05743
 802.741.5000

GAUGE 20 GA
 TUBING: SAE 304
 SPECIES: ALUMINIZED SIL
 FINISH: MILL
 DRAWN: J.C. 4/21/2023
 CHECKED: J.M. 4/21/2023
 APPROVED: J.M. 4/21/2023

WIRE HARNESS P/N 79103
 PART NO **78831**
 W.D.E380 PS638 OT

ALL DIMENSIONS ARE IN INCHES UNLESS OTHERWISE SPECIFIED. DO NOT SCALE DRAWING.

VOLTAGE	TOTAL KILOWATTS	L1	L2	L3	N	ENERGY MANAGEMENT	MAXIMUM % CN
380	25.0	39A	33A	33A	6.7A	YES	84%
380	20.25	38A	33A	33A	6.7A	YES	75%

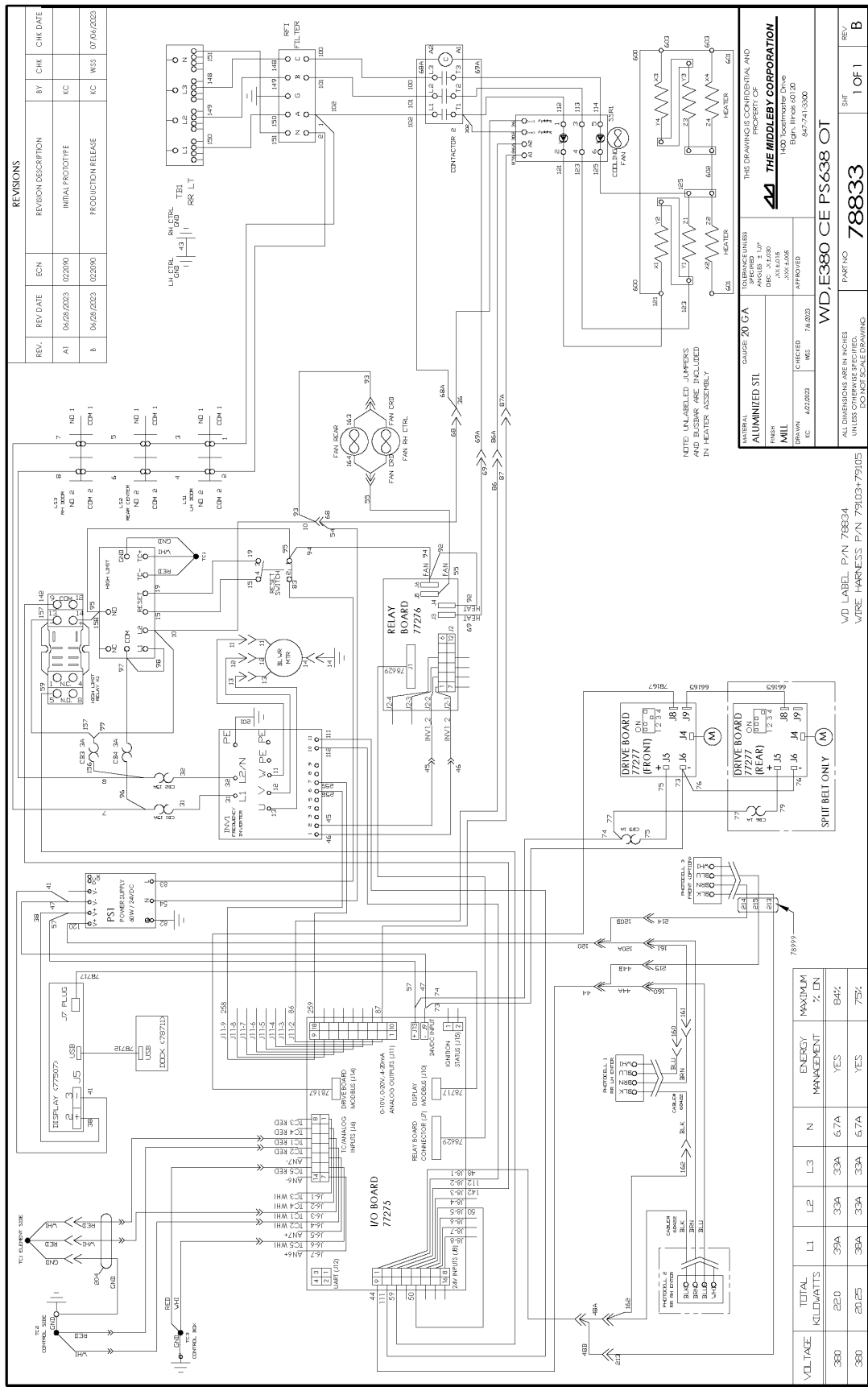

REVISIONS

REV.	REV. DATE	ECH	REVISION DESCRIPTION	BY	CHK	CHK DATE
A1	06/29/2023	022090	INITIAL PROTOTYPE	MC		
B	06/29/2023	022090	PRODUCTION RELEASE	MC	WSS	07/06/2023

THE DRAWING IS CONFIDENTIAL AND SPECIFIED BY THE CUSTOMER.
 THIS DRAWING IS THE PROPERTY OF THE MIDDLEBURY CORPORATION.
 ALL DIMENSIONS ARE IN INCHES UNLESS OTHERWISE SPECIFIED.
 DO NOT SCALE DRAWING.

ALUMINIZED SIL
 GAUGE 20 GA
 TUBING: 3/16" O.D. X 1/8" I.D. AL-305
 WIRE: 24 AWG 7/0.25
 FAN: 115V 0.15A
 HEATER: 115V 60W
 RELAY: 115V 0.1A
 CONTACTOR: 115V 10A
 FUSE: 5A 250V
 DIODE: 1N4007
 RESISTOR: 1/4W 1%
 CAPACITOR: 100UF 50V
 SWITCH: 115V 10A
 MOTOR: 115V 0.1A
 MOTOR: 115V 0.1A

DRAWN: J.C. 4/21/2023
 CHECKED: J.A. 4/21/2023
 APPROVED: J.A. 4/21/2023

PART NO: **78833**
 WIRE HARNESS P/N 79103-79105
 VOLTAGE: 115V
 CURRENT: 0.1A
 POWER: 11.5W

VOLTAGE	TOTAL KILOWATTS	L1	L2	L3	N	ENERGY MANAGEMENT	MAXIMUM % CN
380	25.0	39A	33A	33A	6.7A	YES	B4;
380	20.25	38A	33A	33A	6.7A	YES	75%;

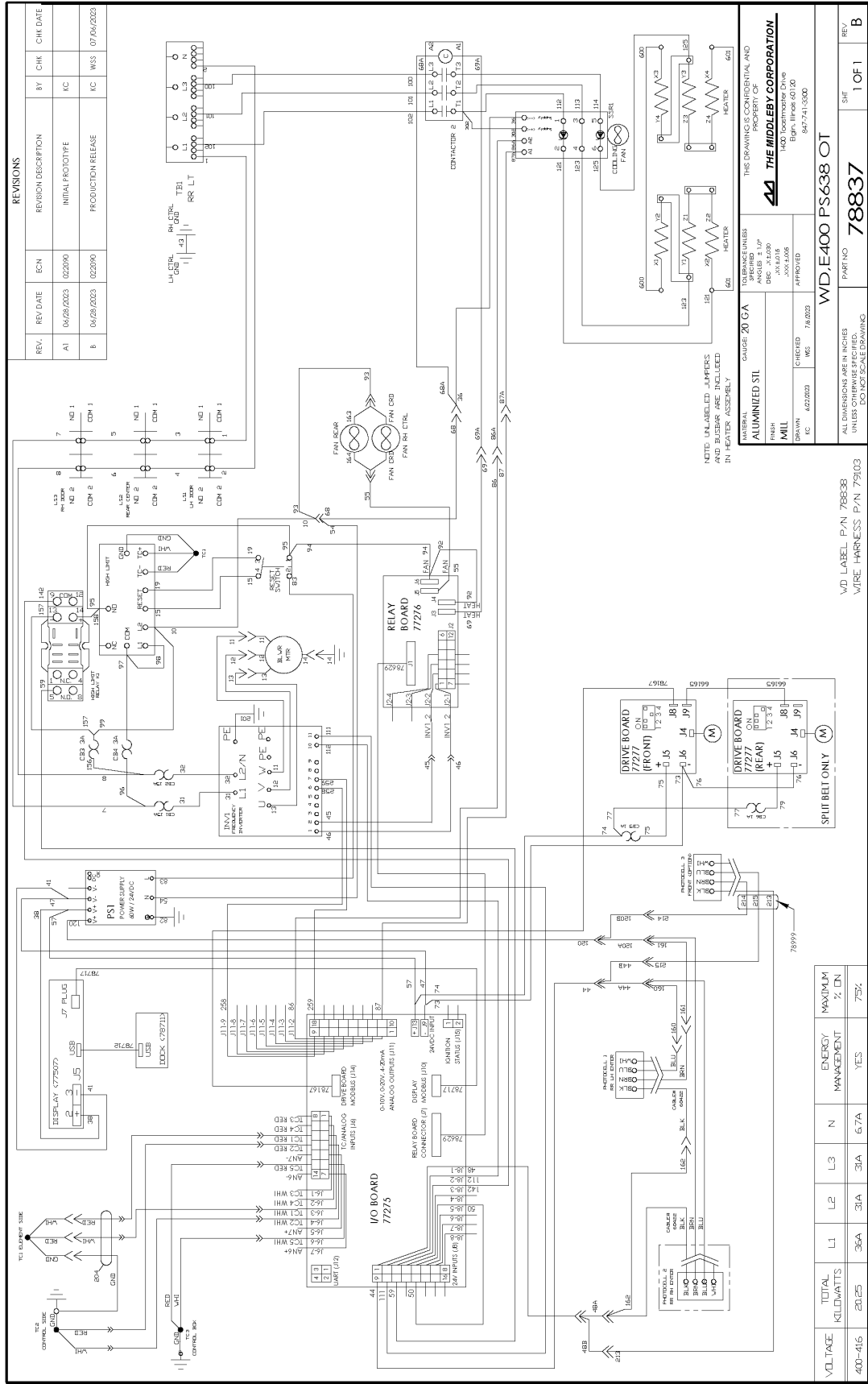

REVISIONS

REV.	REV. DATE	ECH	REVISION DESCRIPTION	BY	CHK	CHK DATE
A1	06/29/2023	022090	INITIAL PROTOTYPE	MC		
B	06/29/2023	022090	PRODUCTION RELEASE	MC	WSS	07/06/2023

THE DRAWING IS CONFIDENTIAL AND SHOULD BE KEPT AS SUCH. THE MIDDLEBY CORPORATION HEADQUARTERS: 10000 BATA WISCONSIN 53000 947.741.5000	
TITLE: ALUMINIZED SILL DRAWN: J.C. 4/21/2023 CHECKED: J.M. 4/21/2023 DESIGNED: J.M. 4/21/2023 APPROVED: J.M. 4/21/2023	PART NO: WD.E400 PS638 OT WIRE HARNESS P/N 79103 VOLTAGE: 480-415 TOTAL KILOWATTS: 20/25 ENERGY MANAGEMENT: YES L1: 36A L2: 31A L3: N L4: 31A MAXIMUM % ON: 75%

WD LABEL P/N 78838
WIRE HARNESS P/N 79103

SHIT 1 OF 1
78837

VOLTAGE	TOTAL KILOWATTS	ENERGY MANAGEMENT	L1	L2	L3	N	MAXIMUM % ON
400-415	20/25	YES	36A	31A	31A	6.7A	75%

REVISIONS						
REV.	REV. DATE	ECN	REVISION DESCRIPTION	BY	CHK	CHK DATE
A1	06/29/2023	022090	INITIAL PROTOTYPE	MC		
B	6/29/2023	022090	PRODUCTION RELEASE	MC	WSS	07/06/2023

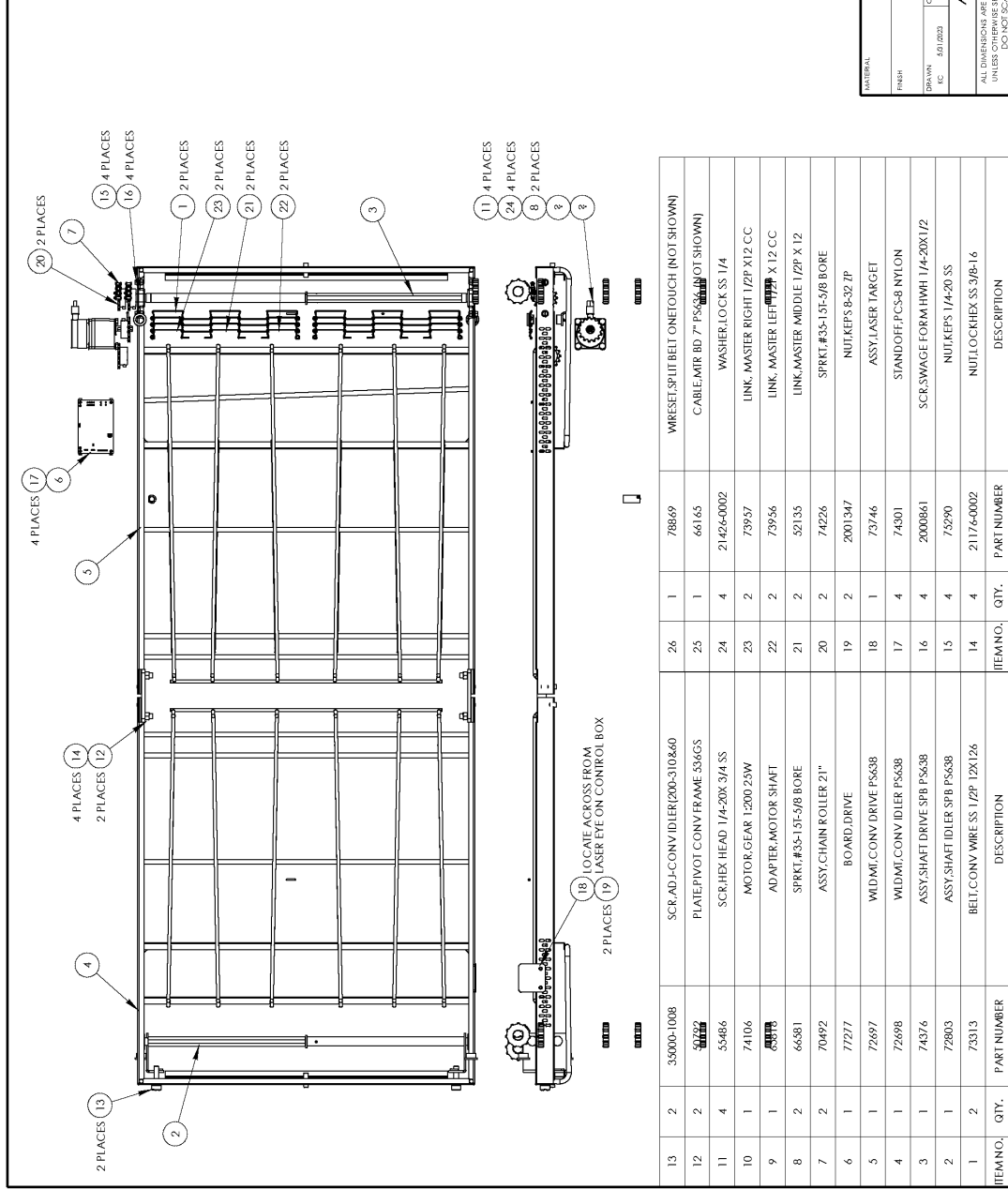

ITEM NO.	QTY.	PART NUMBER	DESCRIPTION	ITEM NO.	QTY.	PART NUMBER	DESCRIPTION
13	2	35000-1008	SCR ADJ CONV IDLER 200-310&40	26	1	78869	WI RESET SPIT BELT ONETOUCH (NOT SHOWN)
12	2	50292	PLATE PIVOT CONV FRAME 53&65	25	1	66165	CABLE MTR BD 7" P5&6 (NOT SHOWN)
11	4	55486	SCR HEX HEAD 1/4-20X 3/4 SS	24	4	21424-0002	WASHER LOCK SS 1/4
10	1	74106	MOTOR GEAR 1200 23W	23	2	73957	LINK MASTER RIGHT 1/2P X12 CC
9	1	68870	ADAPTER MOTOR SHAFT	22	2	73956	LINK MASTER LEFT 1/2P X12 CC
8	2	66581	SPRKT #35-15F-5/8 BORE	21	2	52135	LINK MASTER MIDDLE 1/2P X 12
7	2	70492	ASSY CHAIN ROLLER 21"	20	2	74226	SPRKT #35-15F-5/8 BORE
6	1	77277	BOARD DRIVE	19	2	2001347	NUT KEPS 8-32 ZP
5	1	72697	WDMT CONV DRIVE P5&38	18	1	73746	ASSY LASER TARGET
4	1	72698	WDMT CONV IDLER P5&38	17	4	74901	STAND OFF PCS 8 NYLON
3	1	74376	ASSY SHAFT DRIVE SPB P5&38	16	4	2000861	SCR SWAGE FORM HWHL 1/4-20X 1/2
2	1	72803	ASSY SHAFT IDLER SPB P5&38	15	4	75290	NUT KEPS 1/4-20 SS
1	2	73313	BELT CONV WIRE SS 1/2P 12X126	14	4	21174-0002	NUT LOCK HEX SS 3/8X16

MATERIAL: THE DRAWING IS CONFIDENTIAL AND SPECIFICS ARE 2 1/2" UNLESS OTHERWISE SPECIFIED. DATE: 06/29/2023 BY: JVS, LJS, JWB APPROVED: JVS, LJS, JWB

FINISH: THE MIDDLEBY CORPORATION
 HEADQUARTERS: 11000
 BATA WILSON RD
 847-741-3000

DRAWN: JVS, LJS, JWB
 CHECKED: JVS, LJS, JWB
 DATE: 06/29/2023

ASSY CONVEYOR 13/13 X 38 OT

ALL DIMENSIONS ARE IN INCHES UNLESS OTHERWISE SPECIFIED. DO NOT SCALE DRAWING.

PART NO: 78872 SHF: 1 OF 1 REV: B

REV.	REV DATE	ECN	REVISION DESCRIPTION	BY	CHK	CHK DATE
A1	1/9/2023		INITIAL PROTOTYPE	KC		
A2	06/29/2023	022090	UPDATED PER COMPONENTS	KC		
B	6/29/2023	022090	PRODUCTION RELEASE	KC	WSS	07/10/2023

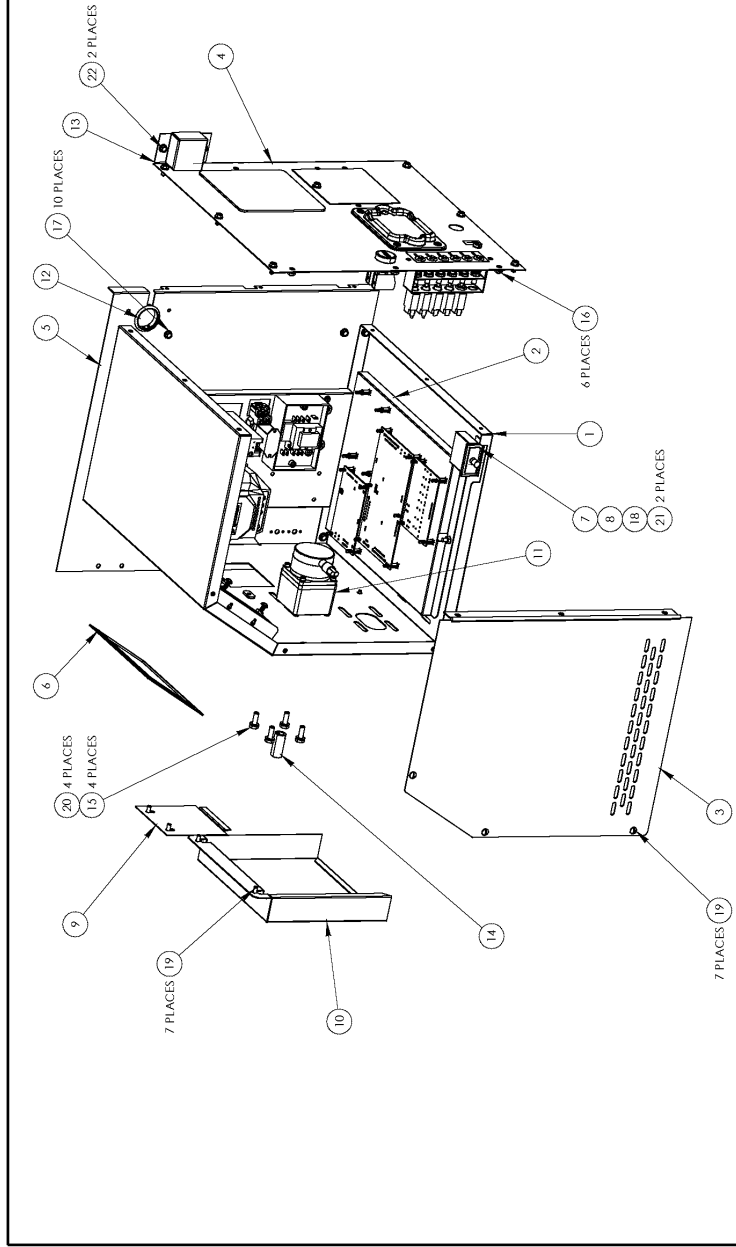

ITEM NO.	QTY.	PART NUMBER	DESCRIPTION	ITEM NO.	QTY.	PART NUMBER	DESCRIPTION
11	1	74106	MOTOR, GEAR 1:200 23W	22	2	2000832	SCR, IREX HWH 10-16X1/2 ZP
10	1	71749	COVER, CONV CHAIN PS638	21	2	21516-001	RIVET, POP STYI #43 GR51 SS
9	1	61161	COVER, PHOTOEYE	20	4	21426-002	WASHER, LOCK, SS 1/4
8	1	68333	INSUL, DOOR SW	19	7	21256-008	SCR, 10-32X3/8 18-8 SL TRUS S
7	1	63909	SWITCH, INTICK 12A NO2P	18	1	35900-0110	BRKT, DOOR SWITCH (PS200)
6	1	77764	BEZEL, ALU	17	10	21296-0005	SCR, HX WSHHD 12-14X3/4 SS BSD
5	1	77898	ASSY, OUTER PLATE RH/FEM	16	6	2001371	NUT, KEPS 10-32 ZP
4	1	78760	ASSY, CTRL REAR BOX	15	4	55486	SCR, HEX HEAD 1/4-20X 3/4 SS
3	1	77779	WID, M, CTRL DOOR RH	14	1	65818	ADAPTER, MOTOR SHAFT
2	1	77870	ASSY, COMP MITG PLT	13	1	72486	BOX, ELECTRIC PS638
1	1	78770	ASSY, CTRL BOX/ONE TOUCH	12	1	55236	BUSHING, OPEN/CLOSED BLACK

THE DRAWING IS CONFIDENTIAL AND
 UNLESS OTHERWISE SPECIFIED,
 ALL DIMENSIONS ARE IN INCHES
 UNLESS OTHERWISE SPECIFIED.
 DO NOT SCALE DRAWING

MATERIAL: THE DRAWING UNLESS SPECIFIED IN NOTES
 FINISH: UNLESS OTHERWISE SPECIFIED
 DRAWN: JF/2023
 CHECKED: JF/2023
 DATE: 7/10/2023
 APPROVED: JF/2023

THE MIDDLEBY CORP
 10000 W. 150TH ST
 BENTON HARBOR, MI 48024
 800.774.1500

PART NO: **77758**
 SHF: 1 OF 1
 REV: B

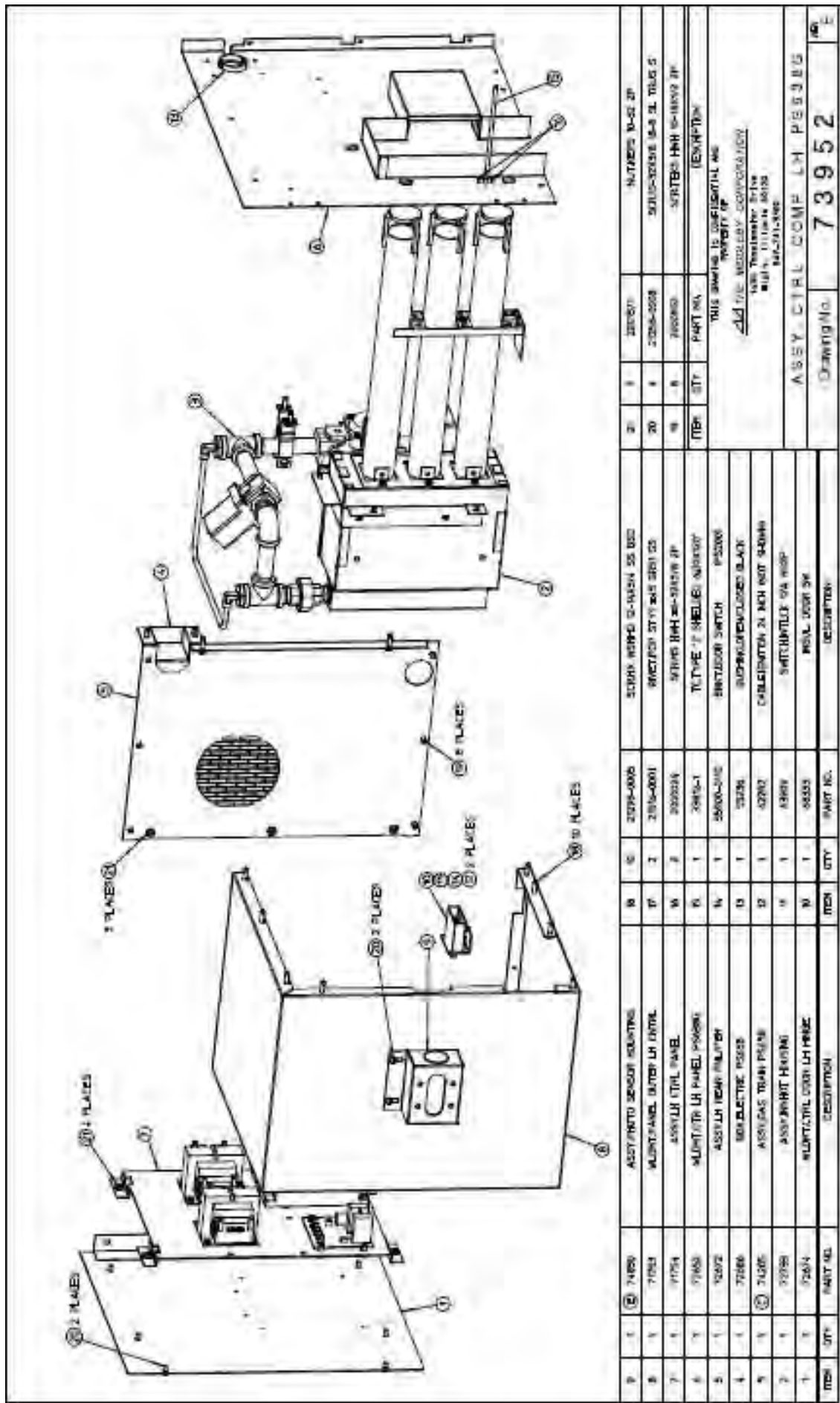

QTY	PART NO.	DESCRIPTION	QTY	PART NO.	DESCRIPTION	QTY	PART NO.	DESCRIPTION
1	7489	ASST INTO SENSOR MOUNTING	1	2079-0005	STRIP WING 2-1/2X4 55 002	1	2079	STRIP WING 2-1/2X4 55 002
1	7153	MOUNT PANEL BUTTER LH ENTRL	2	2105-0001	SWITCH STY 1/4X 2001 02	1	2085-0008	SCRUB-ROTOR 3-3/8 2L TUB 5
1	7174	ASST LH CTRL PANEL	2	200035	STRIP RH 3/4X 2-1/2X 1/8 2P	1	200030	SCRIBER HH 9-18X1/2 2P
1	7163	MOUNT LH PANEL P5080	1	2015-1	TYTPE "J" SHELLS 000107	1	200030	SCRIBER HH 9-18X1/2 2P
1	7202	ASST LH REAR MOUNT	1	2500-010	RETRACTOR SWITCH P5200	1	200030	SCRIBER HH 9-18X1/2 2P
1	7266	SOLELECTRIC P5035	1	2026	INDICATOR/ENCLOSURE BLACK	1	200030	SCRIBER HH 9-18X1/2 2P
1	7426	ASSY GAS TANK P508	1	0282	CALCULATOR 24 NCH 6007 64046	1	200030	SCRIBER HH 9-18X1/2 2P
1	7278	ASSY BRKT HANGING	1	4369	SWITCHABLE 9A 100P	1	200030	SCRIBER HH 9-18X1/2 2P
1	7264	MOUNT CTRL CORR LH PRNC	1	5433	ROSL 0028 24	1	200030	SCRIBER HH 9-18X1/2 2P
1	7264	MOUNT CTRL CORR LH PRNC	1	5433	ROSL 0028 24	1	200030	SCRIBER HH 9-18X1/2 2P
<p>THIS DRAWING IS CONFIDENTIAL AND PROPERTY OF</p> <p>ADD THE NECESSARY CORRECTIONS</p> <p>FOR TRANSMISSION 2-1-76</p> <p>WILLIAMS, WILLIAMS 2018</p> <p>101-211-2002</p>								
<p>ASSY CTRL CORR LH PRNC</p>								
Drawing No.								73952
PART NO.								E

REVISIONS			
REV.	REV. DATE	BY	CHK. DATE
A1	06/25/2023	IC2090	
		INITIAL PROTOTYPE	

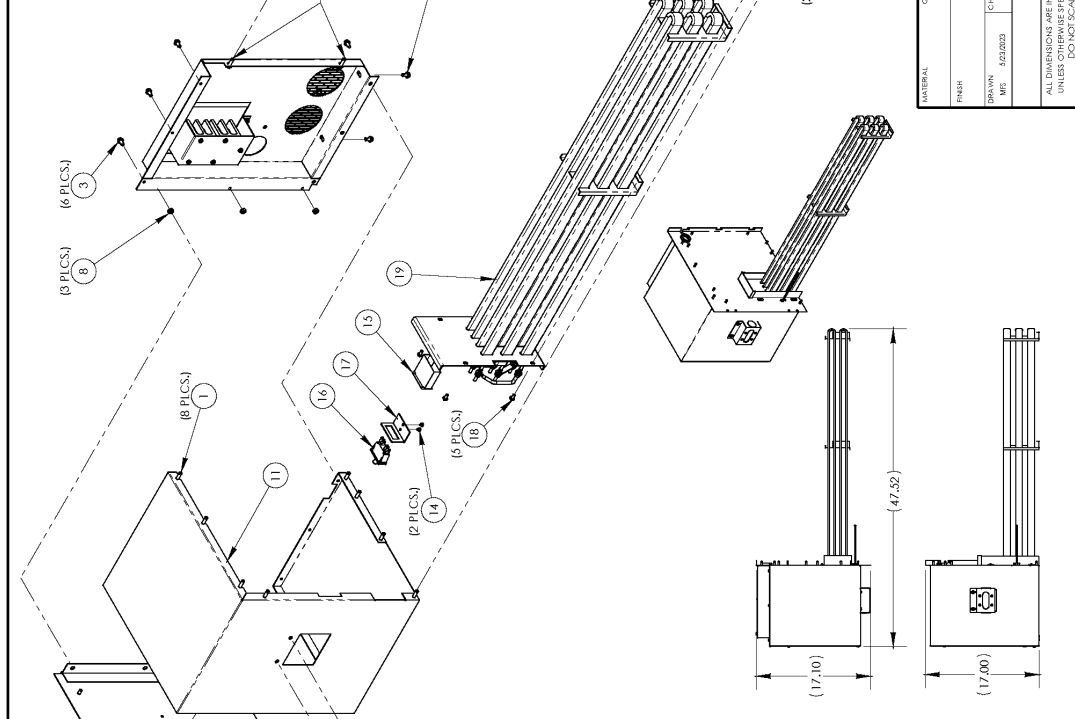

MATERIAL		TOLERANCES UNLESS SPECIFIED		THE DRAWING IS CONFIDENTIAL AND NOT TO BE REPRODUCED WITHOUT THE WRITTEN PERMISSION OF THE MIDDLEBY CORPORATION	
FINISH		ANGLES: 2:1/1/16		DRAWN BY: JWS/FA06	
DRAWN		CHECKED		APPROVED	
REV: 403203				PART NO: 78851	
				REV: A1	

ITEM NO.	QTY.	PART NUMBER	DESCRIPTION
19	1	74124	ELEMENT/HTG 208V 2TRW
18	5	44661	SCR.REG HWH B-32X3/8 NP
17	1	35900-0110	BRKT.DOR SWICH (FS200)
16	1	63909	SWICH.INTCK 12A NO2P
15	1	68333	INSUL.DOR SW
14	2	21516-0001	RIVEL.POP STY1 #43 GR31 SS
13	1	33812-1	TC.TYPE "J" SHIELED 6.00X120"
12	2	2000024	SCR.MS HWH #46-32X3/8 ZP
11	1	71753	WID.MI.PANEL OUTER LH CNTRL
10	1	53256	BUSHING-OPEN/CLOSED BLACK
9	1	78202	ASSY.CTRL COMP 208-380 FS2638
8	3	2001371	NUT.REFS 10-32 ZP
7	1	72674	WID.MI.CTRL DOR LH HINGE
6	4	21256-0008	SCR.10-32X3/8 18-8 ST TRUS S
5	1	76889	ASSY.PHOTO SENSOR MOUNTING
4	1	73638	WID.MI.PIT CTR LH
3	8	2000852	SCR.TEERS HWH 10-16X1/2 ZP
2	1	73652	ASSY.CTRL BACK LH
1	12	21296-0005	SCR.HX WSHHD 12-14X3/4 SS BSD

WARNING

Improper installation, adjustment, alteration, service or maintenance can cause property damage, injury or death. Read the installation, operating and maintenance instructions thoroughly before installing or servicing this equipment.

NOTICE

ALL parts replacement and appliance servicing should be performed by Your Middleby Marshall Authorized Service Agent. Service that is performed by parties other than Your Middleby Marshall Authorized Service Agent may void your warranty.

NOTICE

Using any parts other than genuine Middleby Marshall factory manufactured parts relieves the manufacturer of all warranty and liability.

NOTICE

Middleby Marshall reserves the right to change specifications at any time.

CFESA

Commercial Food Equipment Service Association

Middleby is proud to support the Commercial Food Equipment Service Association (CFESA). We recognize and applaud CFESA's ongoing efforts to improve the quality of technical service in the industry.

Middleby Cooking Systems Group • 1400 Toastmaster Drive • Elgin, IL 60120 • USA • (847)741-3300 • FAX (847)741-4406

www.middleby.com

