

OWNER'S OPERATING & INSTALLATION MANUAL

**PS3240G-Series Gas Ovens
Model PS3240G**

Combinations:

- Single Oven
- Double Oven (Two-Stack)
- Triple Oven (Three-Stack)

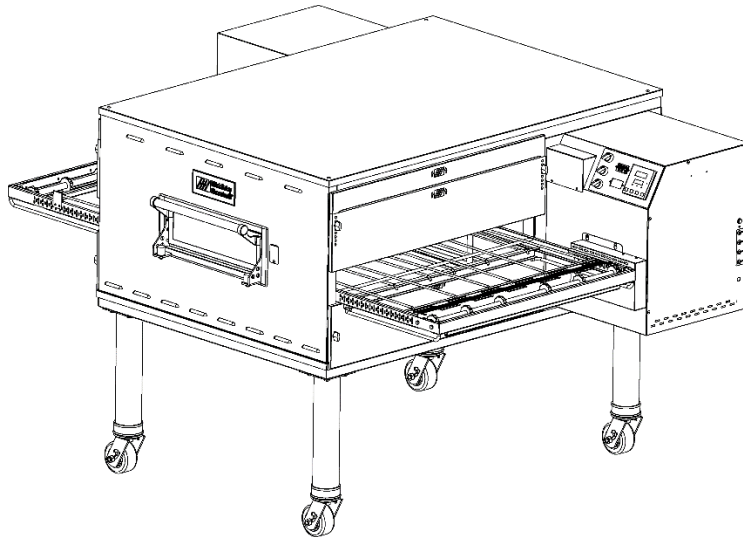

© 2021 Middleby Marshall Inc.



is a registered trademark of Middleby Marshall, Inc. All rights reserved.



NOTICE:

This Owner's Operating and Installation Manual should be given to the user. The operator of the oven should be familiar with the function and operation of the oven.

This manual must be kept in a prominent, easily reachable location near the oven.

Ovens are shipped from the factory configured for use with Natural gas. If permitted by local, national, and international codes, at the time of installation the oven may be converted to Propane gas operation. This conversion requires the use of a Gas Conversion Kit that is supplied with the oven.

For CE-approved ovens, the conversion is described in the Installation section of this manual.

For domestic and standard export ovens, instructions are included in the Gas Conversion Kit.

Middleby Marshall suggests a service contract with a Middleby Authorized Service Agent (ASA).

DEFINITIONS

DANGER
INDICATES A HAZARDOUS SITUATION THAT, IF NOT AVOIDED, WILL RESULT IN DEATH OR SERIOUS INJURY.

WARNING
Indicates a hazardous situation that, if not avoided, could result in death or serious injury.

CAUTION
Indicates a hazardous situation that, if not avoided, could result in minor or moderate injury.

NOTICE
Indicates situations not related to physical injury that, if not avoided, could cause damage to the machine or surrounding property and could affect warranty coverage.

IMPORTANT
Includes other information required by the operator or installer.

WARNING
This appliance is not intended for use by persons (including children) with reduced physical, sensory or mental capabilities, or lack of experience and knowledge, unless they have been given supervision or instruction concerning use of the appliance by a person responsible for their safety.

- ***Children should be supervised to ensure that they do not play with the appliance.***
- ***Cleaning and user maintenance shall not be made by children without supervision.***

WARNING

In a prominent location, post the emergency telephone number of your local gas supplier and instructions to be followed in the event you smell gas. Instructions to be followed in the event the user smells gas shall be obtained by consulting the local gas supplier. If the smell of gas is detected, immediately call the emergency phone number of your local gas company. They will have personnel and provisions available to correct the problem.

WARNING

Do not spray aerosols in the vicinity of this appliance while it is in operation.

WARNING

For your safety, do not store or use gasoline or other flammable vapors and liquids in the vicinity of this or any other appliance.

WARNING

Improper installation, adjustment, alteration, service, or maintenance can cause property damage, injury, or death. Read the installation, operation, and maintenance instructions thoroughly before installing or servicing the equipment.

IMPORTANT

An electrical wiring diagram for the oven is located inside the machinery compartment.

IMPORTANT

It is the customer's responsibility to report any concealed or non-concealed damage to the freight company. Retain all shipping materials until it is certain that the equipment has not suffered concealed shipping damage.

NOTICE

Contact your Middleby Authorized Service Agent to install and perform maintenance and repairs and if necessary to convert equipment for use with other gases. An authorized service agency directory is supplied with your oven and available here: <https://middlebymarshall.com>

NOTICE

Using parts other than genuine Middleby Marshall Factory manufactured parts relieves the manufacturer of all warranty and liability.

NOTICE

Middleby Marshall (Manufacturer) reserves the right to change specifications at any time.

NOTICE

The equipment warranty is not valid unless the oven is installed, started, and demonstrated under the supervision of a factory certified installer.

NOTICE

The equipment is only for professional use and shall be used by qualified personnel.

RETAIN THIS MANUAL FOR FUTURE REFERENCE

**MIDDLEBY MARSHALL
NO QUIBBLE LIMITED WARRANTY
(U.S.A. ONLY)**

MIDDLEBY MARSHALL HEREINAFTER REFERRED TO AS "THE SELLER", WARRANTS EQUIPMENT MANUFACTURED BY IT TO BE FREE FROM DEFECTS IN MATERIAL AND WORKMANSHIP FOR WHICH IT IS RESPONSIBLE. THE SELLER'S OBLIGATION UNDER THIS WARRANTY SHALL BE LIMITED TO REPLACING OR REPAIRING AT SELLER'S OPTION, WITHOUT CHARGE, ANY PART FOUND TO BE DEFECTIVE AND ANY LABOR AND MATERIAL EXPENSE INCURRED BY SELLER IN REPAIRING OR REPLACING SUCH PART. SUCH WARRANTY SHALL BE LIMITED TO THE ORIGINAL PURCHASER ONLY AND SHALL BE EFFECTIVE FOR A PERIOD OF ONE YEAR FROM DATE OF ORIGINAL INSTALLATION OR 18 MONTHS FROM DATE OF PURCHASE, WHICHEVER IS EARLIER, PROVIDED THAT TERMS OF PAYMENT HAVE BEEN FULLY MET.

This warranty is valid only if the equipment is installed, started, and demonstrated under the supervision of a factory-authorized installer.

Abuse, acts of God, belt jams, cleaning, customer abuse, insufficient utilities, lubrication, maintenance, non-oven related issues, preventative maintenance, or normal maintenance function including adjustment of airflow, burners, conveyor components, door mechanisms, microswitches, pilot burners, thermostats, and replacement of bushings, light bulbs, fuses, indicating lights, and wear points, are not covered by this **no quibble warranty**.

Seller shall be responsible only for repairs or replacements of defective parts performed by Seller's authorized service personnel. Authorized service agencies are located in principal cities throughout the contiguous United States, Alaska, and Hawaii. This warranty is valid in the 50 United States and is void elsewhere unless the product is purchased through Middleby International with warranty included.

The foregoing warranty is exclusive and in lieu of all other warranties, expressed or implied. There are no implied warranties of merchantability or of fitness for a particular purpose.

The foregoing shall be the Seller's sole and exclusive obligation and Buyer's sole and exclusive remedy for any action, including breach of contract or negligence. In no event shall Seller be liable for a sum in excess of the purchase price of the item. Seller shall not be liable for any prospective or lost profits of the buyer.

This warranty is effective on Middleby Marshall equipment sold on, or after January 1st, 2007.

© 2019 - Middleby Marshall, A Middleby Company.

**MIDDLEBY MARSHALL
OVEN LIMITED WARRANTY
(Non U.S.A.)**

The Seller warrants equipment manufactured by it to be free from defects in material and workmanship for which it is responsible. The Seller's obligation under this warranty shall be limited to replacing or repairing, at Seller's option, without charge, F.O.B. Seller's factory, any part found defective and any labor and material expense incurred by Seller in repairing or replacing such part. Such warranty is limited to a period of one year from the date of original installation or 15 months from date of shipment from Seller's factory, whichever is earlier, provided that terms of payment have been fully met. All labor shall be performed during regular working hours. Overtime premium will be charged to the Buyer.

This warranty is not valid unless equipment is installed, started, and demonstrated under the supervision of a factory-authorized installer.

Normal maintenance functions including lubrication, adjustment of airflow, thermostats, door mechanisms, microswitches, burners and pilot burners, and replacement of light bulbs, fuses, and indicating lights, are not covered by warranty.

Any repair or replacement of defective parts shall be performed by Seller's authorized service personnel. Seller shall not be responsible for any costs incurred if the work is performed by anyone other than the Seller's authorized service personnel.

When returning any part under warranty, the part must be intact and complete, without evidence of misuse or abuse, freight prepaid.

Seller shall not be liable for any consequential damages of any kind which occur during the course of installation of equipment, or which result from the use or misuse by Buyer, its employees or others of the equipment supplied hereunder. Buyer's sole and exclusive remedy against Seller for any breach of the foregoing warranty or otherwise shall be for the repair or replacement of the equipment or parts thereof affected by such breach.

The foregoing warranty shall be valid and binding upon Seller if and only if Buyer loads, operates, and maintains the equipment supplied hereunder in accordance with the instruction manual provided to Buyer. Seller does not guarantee the process of manufacture by Buyer or quality of product to be produced by the equipment supplied hereunder and Seller shall not be liable for any prospective or lost profits of Buyer.

The foregoing shall be Seller's sole and exclusive obligation and Buyer's sole and exclusive remedy for any action, whether in breach of contract or negligence. In no event shall Seller be liable for a sum in excess of the purchase price of the item.

THE FOREGOING WARRANTY IS EXCLUSIVE AND IN LIEU OF ALL OTHER EXPRESS AND IMPLIED WARRANTIES WHATSOEVER. SPECIFICALLY THERE ARE NO IMPLIED WARRANTIES OF MERCHANTABILITY OR FITNESS FOR A PARTICULAR PURPOSE.

Table of Contents

SECTION 1 DESCRIPTION	5	B. Gas Conversion	22
I. MODEL IDENTIFICATION	5	C. PS3240 Propane Conversion	22
II. PS3240 SERIES SPECIFICATIONS	6	D. Adjusting the Maximum Pressure Setting	22
III. COMPONENT FUNCTION	7	E. Adjusting the Minimum Pressure Setting	23
A. Conveyor Drive Motor	7	F. Checkout	23
B. Crumb Trays	7	G. Maintenance	23
C. Conveyor	7	SECTION 3 OPERATION	25
D. End Plugs	7	I. LOCATION AND DESCRIPTION	
E. Eyebrows	7	OF CONTROLS	25
F. Window	7	A. "BLOWER" Switch	25
G. Machinery Compartment Access Panel	7	B. "HEAT" Switch	25
H. Serial Plate	7	C. "CONVEYOR" Switch	25
I. Control Panel	7	D. Conveyor Speed Controller	25
J. Gas Burner (gas ovens)	7	E. Digital Temperature Controller	25
K. Blowers	7	F. Machinery and Control Compartment Safety	
L. Air Fingers	7	Switches (<i>NOT SHOWN</i>)	25
SECTION 2 INSTALLATION	9	II. STEP-BY-STEP OPERATION	26
I. UNLOADING AND ROUGH-IN	10	A. Daily Start-up Procedure	26
II. VENTILATION GUIDELINES	14	B. Daily Shutdown Procedure	26
A. Requirements	14	C. Power Failure	27
B. Recommendations	14	III. TEMPERATURE CONTROLLER OPERATION	28
C. Other Ventilation Concerns	14	A. Operation Adjustments	28
III. ASSEMBLY	15	B. Programming Adjustments	28
A. Top Panel and Base Pad Assembly	15	SECTION 4 MAINTENANCE	29
B. Stacking	16	I. MAINTENANCE - DAILY	29
C. Restraint Cable Installation	17	II. MAINTENANCE - MONTHLY	30
D. Conveyor Installation	17	III. MAINTENANCE - EVERY 3 MONTHS	31
E. Final Assembly	18	A. Split Belt Disassembly and Cleaning	31
F. Conveyor Belt Reversal	19	B. Blower Belt	32
IV. ELECTRICAL SUPPLY	20	IV. MAINTENANCE - EVERY 6 MONTHS	33
A. Electrical Connection	21	V. KEY SPARE PARTS	34
V. GAS SUPPLY	21	SECTION 5 TROUBLESHOOTING	37
A. Gas Connection	21	SECTION 6 ELECTRICAL SCHEMATICS	39

SECTION 1 DESCRIPTION

I. MODEL IDENTIFICATION

PS3240 Series Ovens can be used to bake and/or cook a wide variety of food products, such as pizza, pizza-type products, cookies, sandwiches, and others. The PS3240 may be used either as a single oven or stacked for use as double or triple ovens.

A single PS3240G-Series Oven is mounted on a base with 15" (381mm) legs and casters. A double oven is mounted on a base with 6" (152mm) legs and casters. A triple oven is mounted on a base with casters.

On a double or triple oven, the ovens operate independently. All ovens use identical controls and components. One oven can be cleaned or serviced, while the others are operating.

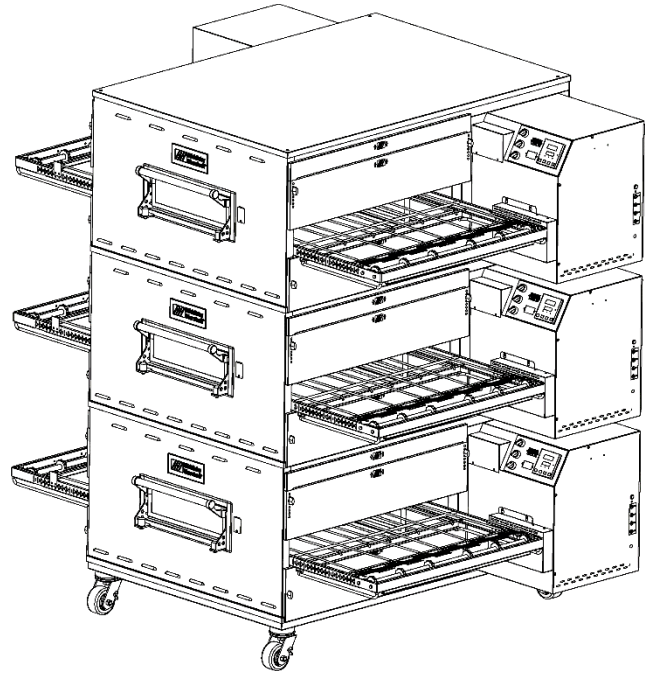

Figure 1. PS3240G-3 Triple Oven

SECTION 1
DESCRIPTION

II. PS3240 SERIES SPECIFICATIONS

RECOMMENDED MINIMUM CLEARANCES

	<i>Rear of Oven to Wall</i>	<i>Control end of Conveyor to Wall</i>	<i>Non-control end of Conveyor to Wall</i>
Domestic and std. export	0" (0mm)	0" (0mm)	0" (0mm)

PS3240G SERIES OVEN SPECIFICATIONS

<i>Dimensions</i>	<i>Single Oven</i>	<i>Double Oven</i>	<i>Triple Oven</i>
Overall Height	47-1/8" (1,197mm)	61-3/4" (1,568mm)	77-5/8" (1,972mm)
Overall Depth	60" (1,524mm)	60" (1,524mm)	60" (1,524mm)
Overall Length	76-1/2" (1,930mm)	76-1/2" (1,930mm)	76-1/2" (1,930mm)
Conveyor Width — belt width is 32"	33-1/2" (838mm) or 2 x 15" (381mm)	33-1/2" (838mm) or 2 x 15" (381mm)	33-1/2" (838mm) or 2 x 15" (381mm)

General Specifications

Weight	1,150 lbs. (522kg)
Rated Heat Input (per oven cavity)	99,000 BTU (25,000kcal, 29 kW/hr)
Maximum Operation Temperature	600°F / 315°C
Air Blowers	Two Blowers at 1900 RPM
Warm-up Time	15 minutes

PS3240G SERIES ELECTRICAL SPECIFICATIONS

<i>Main Blower Voltage</i>	<i>Control Circuit Voltage</i>	<i>Phase</i>	<i>Frequency</i>	<i>Current Draw*</i>	<i>Poles</i>	<i>Wires</i>
208-240VAC	208-240VAC	1	50/60 Hz	10-4.5 Amps	2	3 Wire (2 hot, 1 ground)

* The current draw ratings shown above are maximum values for normal operation, amperage draw will be less than the listed value.

NOTE: Each oven includes a 6 ft cord with NEMA# L6-20P plug. Customer to provide NEMA# L6-20R receptacle.

PS3240G SERIES GAS SUPPLY SPECIFICATIONS

<i>Gas Type</i>	<i>Inlet Pressure**</i>	<i>Manifold Pressure</i>	<i>Main Orifice Diameter**</i>	<i>Bypass Pressure**</i>
Natural	8-12" W.C. (20-30 mbar)	3.5" W.C. (8.7 mbar)	0.1065" (2.71mm) Dia.	0.25-0.3" W.C. (0.6-0.8 mbar)
Propane	11-14" W.C. (27.4-34.9 mbar)	10.0" W.C. (24.9 mbar)	0.067" (1.702mm) Dia.	0.9-1.0" W.C. (2.2-2.5 mbar)

** The gas supply pressures and orifice sizes shown are for ovens installed in North America. The required gas supply pressures and orifice sizes of ovens installed in other locations are dependent on the local gas type and on all applicable local codes.

GAS ORIFICE AND PRESSURE SPECIFICATIONS (PER OVEN CAVITY) - CE OVENS

<i>Gas Type</i>	<i>Main Orifice dia.</i>	<i>Supply (Inlet) Pressure</i>						<i>Orifice (Manifold) Pressure</i>	<i>Rated Heat Input</i>
		<i>IT,PT,ES,SE,UK, CH,IT,AT,DK,FI I_{2H}</i>	<i>NL I_{2L}</i>	<i>DE I_{2E}</i>	<i>BE,FR I_{2E+}</i>	<i>SE,CH,AT,DK, FI,DE,NL I_{3B/P}</i>	<i>BE,IE,IT,PT, ES,UK I₃₊</i>		
G20	0.120" (3.05 mm)	20 mbar	--	20 mbar	20 mbar	--	--	11.21 mbar	22.36 kW-hr.
G25	0.120" (3.05 mm)	--	25 mbar	--	--	--	--	16.19 mbar	22.36 kW-hr.
G30	0.075" (1.9 mm)	--	--	--	--	29 or 50 mbar	28-30, 37 or 50 mbar	26.2 mbar	22.59 kW-hr.

NOTE: Wiring Diagrams are contained in Section 6 of this manual and are also located inside the oven at the bottom of the Control Panel. Additional electrical information is provided on the oven's serial plate.

This Manual Must Be Kept For Future Reference.

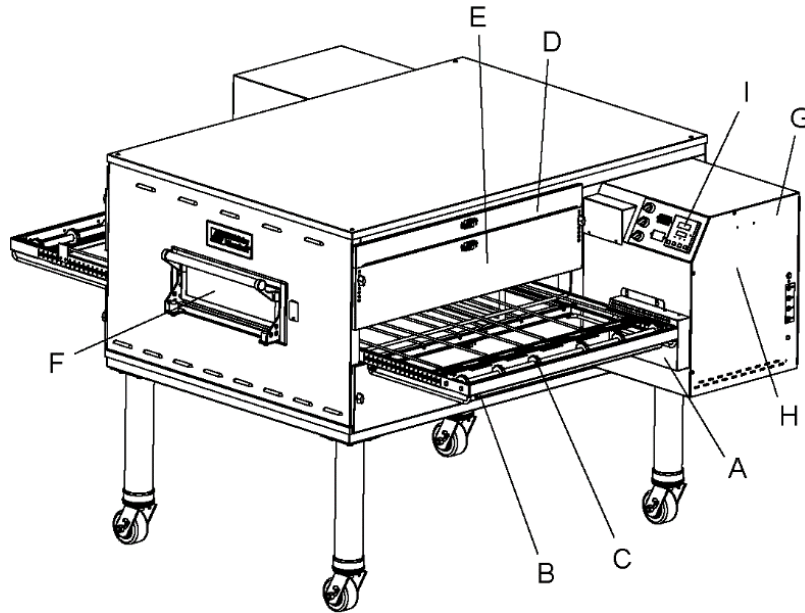

Figure 2. PS3240G-Series Oven Component Locations

III. COMPONENT FUNCTION

A. Conveyor Drive Motor

Moves the conveyor.

B. Crumb Trays

Catch crumbs and other materials that drop through the conveyor belt. One crumb tray is located at each end of the conveyor.

C. Conveyor

Moves the food product through the oven.

D. End Plugs

Allow access to the oven's interior.

E. Eyebrows

Can be adjusted to various heights to prevent heat loss into the environment.

F. Window

Allows the user to access food products inside the baking chamber.

G. Machinery Compartment Access Panel

Allows access to the oven's interior and control components. No user serviceable parts are located in the machinery compartment.

H. Serial Plate

Provides specifications for the oven that affect installation and operation. Refer to Section 2, Installation, for details.

I. Control Panel

Location of the operating controls for the oven. Refer to Section 3, Operation, for details.

Not Shown

J. Gas Burner (gas ovens)

Heat air, which is then projected to the air fingers by the blowers.

K. Blowers

Project hot air from the burner or heating element to the air fingers.

L. Air Fingers

Project streams of hot air onto the food product.

SECTION 1
DESCRIPTION

NOTES

SECTION 2 INSTALLATION

WARNING

After any conversions, readjustments, or service work on the oven:

- *Perform a gas leak test.*
- *Test for correct air supply, particularly to the burner blower.*
- *Test for proper combustion and gas supply.*
- *Check that the ventilation system is in operation.*

WARNING

Keep the appliance area free and clear of combustibles.

WARNING

The oven must be installed on an even (level) non-flammable flooring and any adjacent walls must not be flammable. Recommended minimum clearances are specified in the Description section of this manual.

WARNING

Do not obstruct the flow of combustion and ventilation air to and from your oven. There must be no obstruction around or underneath the oven. Constructional changes to the area where the oven is installed shall not affect the air supply to the oven.

CAUTION

To reduce the risk of fire, the appliance is to be mounted on floors of noncombustible construction with noncombustible flooring and surface finish and with no combustible material against the underside thereof, or on noncombustible slabs or arches having no combustible material against the underside thereof. Such construction shall in all cases extend not less than 12 inches (304mm) beyond the equipment on all sides.

NOTICE

For additional installation information, contact your local Authorized Service Agent.

NOTICE

There must be adequate clearance between the oven and combustible construction. Clearance must also be provided for servicing and for proper operation.

IMPORTANT

An electrical wiring diagram for the oven is located inside the machinery compartment.

NOTE: All aspects of the oven installation, including placement, utility connections, and ventilation requirements, must conform to any applicable local, national, or international codes. These codes supersede the requirements and guidelines provided in this manual.

NOTE: In the USA, the oven installation must conform to local codes. In the absence of local codes, gas oven installations must conform with the National Fuel Gas Installation Code, ANSI Z223.1. Gas and electric ovens, when installed, must be electrically grounded in accordance with local codes, or in the absence of local codes, with the National Electrical Code (NEC) or ANSI/NFPA 70.

NOTE: In Canada, the oven installation must conform to local codes. In the absence of local codes, gas oven installations must conform to the Natural Gas Installation Code, CAN/CGA-B149.1, or Propane Gas Installation Code, CAN/CGA-B149.2, as applicable. Gas and electric ovens, when installed, must be electrically grounded in accordance with local codes, or in the absence of local codes, with Canadian Electrical Code, CSA C22.2.

NOTE: In Australia, the oven installation must conform with local codes. In the absence of local codes, gas oven installations must conform with the requirements of AS5601/AG601, Gas, Electricity, and any other relevant statutory regulations.

CAUTION

It is recommended that the oven be placed under a ventilation hood for adequate air supply and ventilation.

SECTION 2
INSTALLATION

I. UNLOADING AND ROUGH-IN

Your Middleby Marshall PS3240G-Series Oven is shipped partially assembled. It will arrive in a carton on a crate.

The crate and carton must be examined before signing the Bill of Lading. Report any visible damage to the transport company, and check for the proper number

of crates. If apparent damage is found, make arrangements to file a claim against the carrier. Surface Interstate Commerce Regulations (U.S.A.) require that the claim must be initiated by the consignee within 10 days from the date that the shipment is received.

**PS3240G
OVEN INSTALLATION
REQUIRED KITS AND EQUIPMENT**

	<i>Gas Oven Installation Kit</i> <i>P/N 61033</i>	<i>Single Oven Option Base w/15" Legs, Casters & Top Kit</i> <i>P/N 66957</i>	<i>Double Oven Option Base w/6" Legs, Casters & Top Kit</i> <i>P/N 66958</i>	<i>Triple Oven Option Base w/Casters & Top Kit</i> <i>P/N 66164</i>
PS3240G-1	1	1		
PS3240G -2	2		1	
PS3240G -3	3			1

**PARTS LIST FOR PS3240G-SERIES GAS OVEN INSTALLATION KIT
P/N 61033**

**(Two required for double oven)
(Three required for triple oven)**

ITEM NO.	QTY	PART NO.	DESCRIPTION
1	1	22361-0001	FLEXIBLE GAS HOSE
2	1	61823	CONVEYOR END STOP
3	1	72835	CONVEYOR LEFT REAR STOP
4	1	42612	SERVICE AGENCY DIRECTORY
5	1	62307	VALVE, GAS MANUAL BALL 1/2 x 1/2
6	1	51054	ASSY, HANDLE & DOOR
7	1	72782	ASSY, TAP & ADAPTER

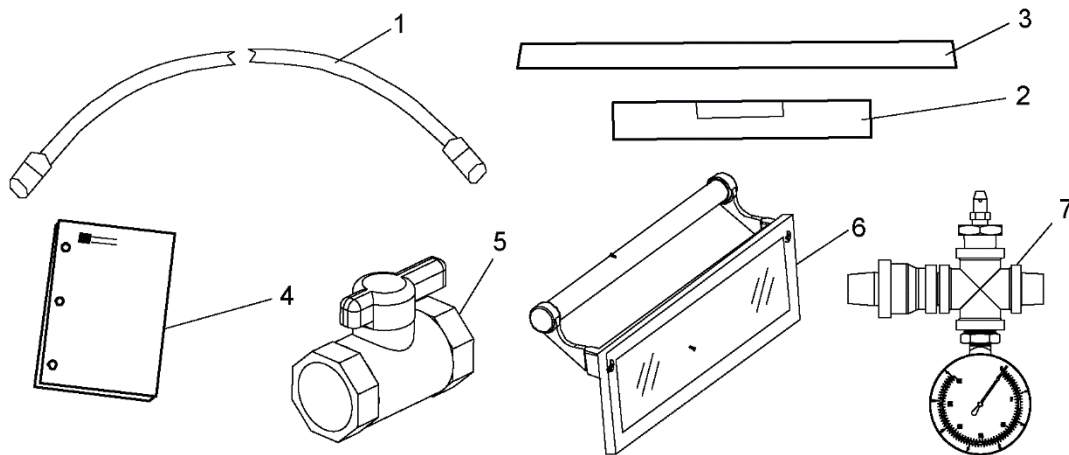

Figure 3. PS3240G-Series Gas Oven Installation Parts

**PARTS LIST FOR PS3240G-SERIES SINGLE OVEN OPTION
BASE w/15" LEGS AND TOP
P/N 66957**

ITEM NO.	QTY	PART NO.	DESCRIPTION
1	4	66948	LEG, 15" COMMON TUBE & CASTER
2	1	66159	COMPLETE BASE WELDMENT
3	1	59673	TOP COVER
4	4	21422-0016	1/2" SPLIT LOCK WASHER, PT
5	16	21422-0001	3/8" SPLIT LOCK WASHER, ZP
6	16	21411-0002	3/8" FLAT WASHER, PL
7	16	1513D8805	CAP SCREW, HX HD 3/8-16 x 3/4 NP
8	4	2001045	CAP SCREW, HX HD 1/2-13 x 1 ZP
9	1	22450-0228	RESTRAINT CABLE ASSEMBLY

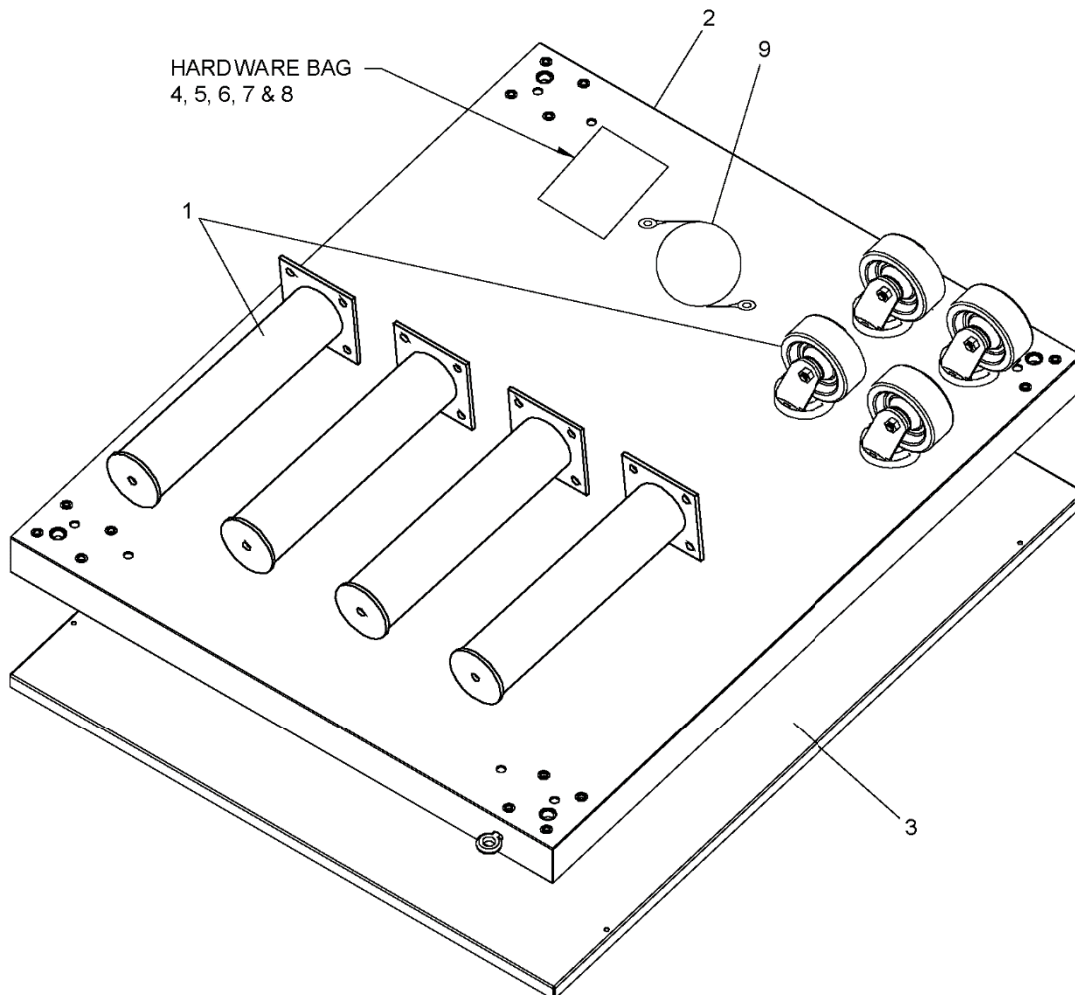

Figure 4. Model PS3240G Single Oven Option Base with Legs and Top

SECTION 2
INSTALLATION

**PARTS LIST FOR PS3240G-SERIES DOUBLE OVEN OPTION
BASE w/6" LEGS AND TOP
P/N 66958**

ITEM NO.	QTY	PART NO.	DESCRIPTION
1	4	66946	LEG, 6" COMMON TUBE & CASTER
2	1	66159	COMPLETE BASE WELDMENT
3	1	59673	TOP COVER
4	4	21422-0016	1/2" SPLIT LOCK WASHER, PT
5	16	21422-0001	3/8" SPLIT LOCK WASHER, ZP
6	16	21411-0002	3/8" FLAT WASHER, PL
7	16	1513D8805	CAP SCREW, HX HD 3/8-16 x 3/4 NP
8	4	2001045	CAP SCREW, HX HD 1/2-13 x 1 ZP
9	1	22450-0228	RESTRAINT CABLE ASSEMBLY

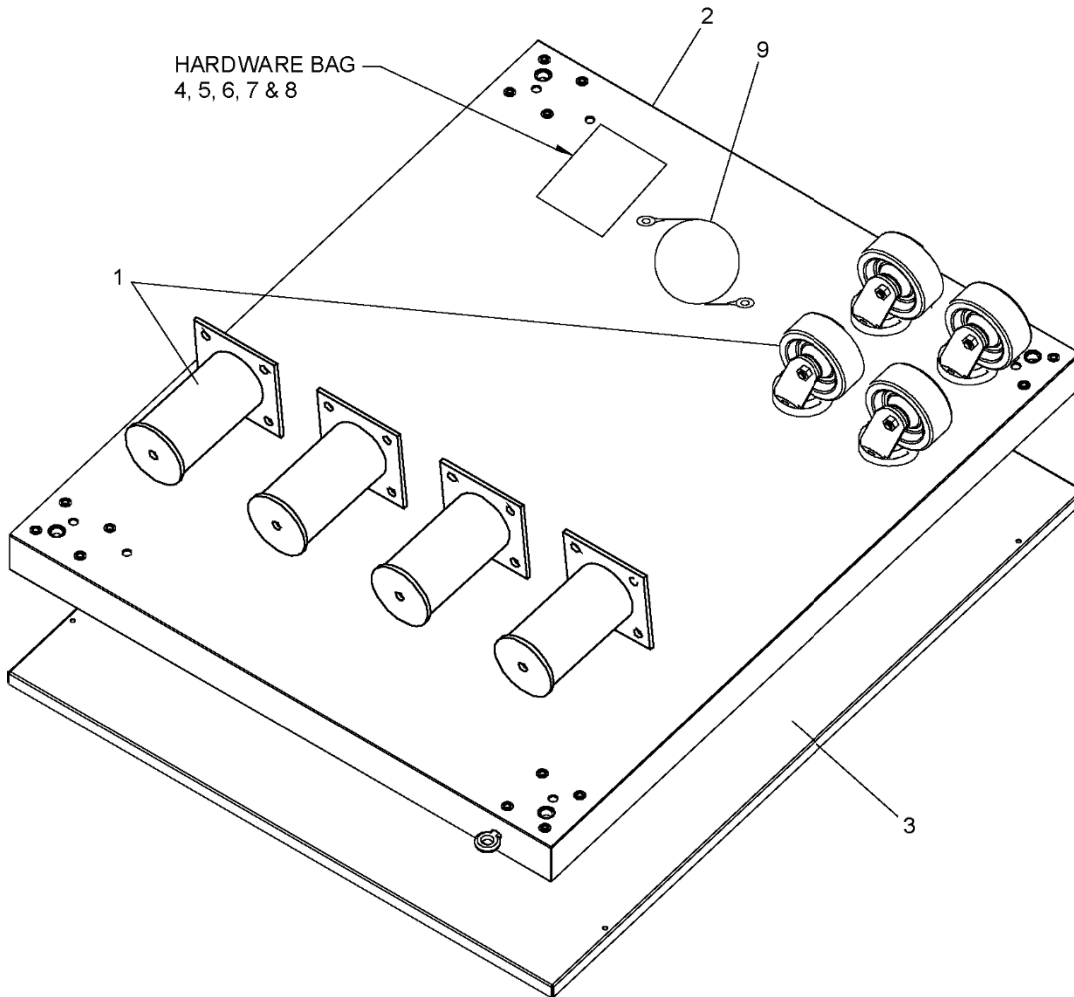

Figure 5. Model PS3240G Double Oven Option Base with Legs and Top

**PARTS LIST FOR PS3240G-SERIES TRIPLE OVEN OPTION
BASE w/CASTERS AND TOP
P/N 66164**

ITEM NO.	QTY	PART NO.	DESCRIPTION
1	2	22290-0009	SWIVEL CASTER W/BRAKE FLAT PLATE
2	2	22290-0010	SWIVEL CASTER FLAT PLATE
3	4	61783	QUAD OUTRIGGER WELDMENT
4	1	59673	TOP COVER
5	1	66159	COMPLETE BASE WELDMENT
6	4	61782	PLATE, SPACER 1/2"
7	1	22450-0228	RESTRAINT CABLE ASSEMBLY

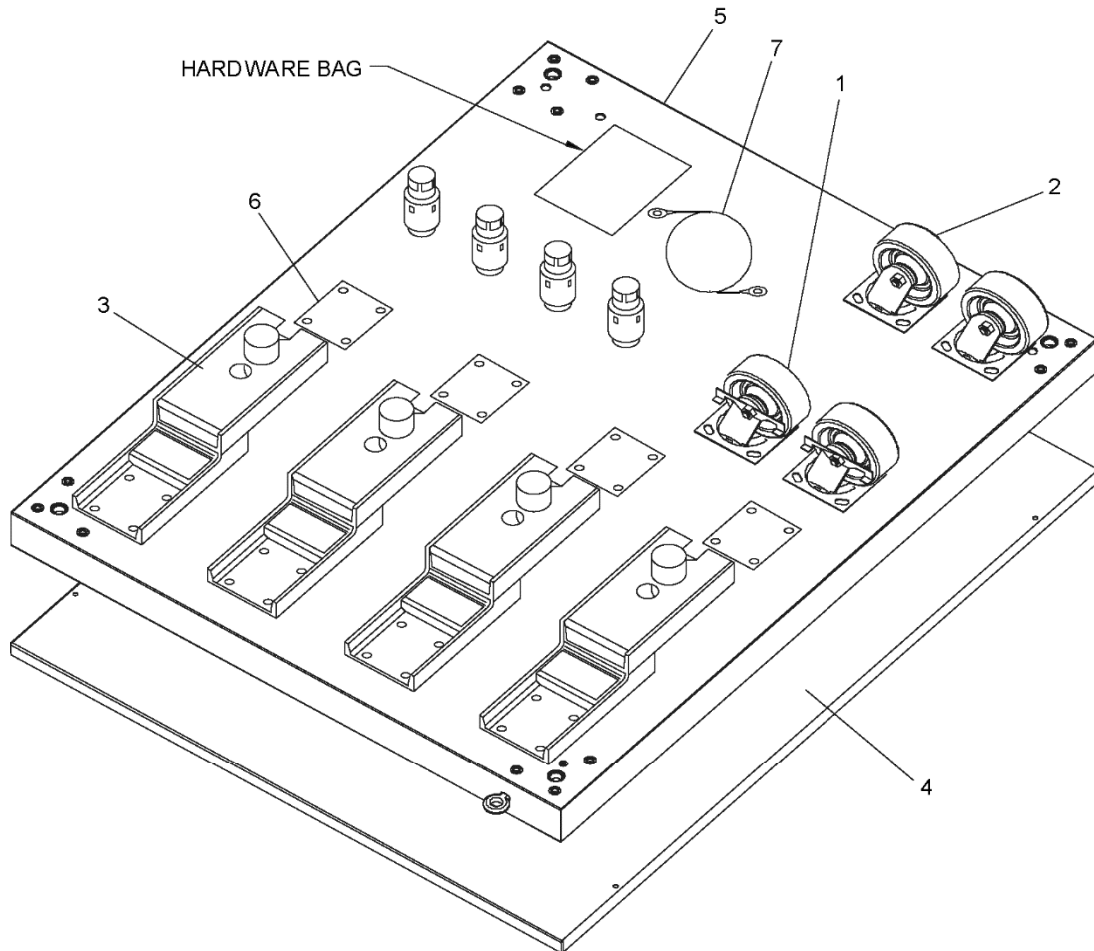

Figure 6. Model PS3240G Triple Oven Option Base with Outriggers and Top

II. VENTILATION GUIDELINES

A. Requirements

NOTICE

Gas oven installations REQUIRE a mechanically driven ventilation system with electrical exhaust air sensing control. Proper ventilation of the oven is the responsibility of the owner.

B. Recommendations

NOTE THAT THE HOOD DIMENSIONS SHOWN IN Figure 7 ARE RECOMMENDATIONS ONLY. LOCAL, NATIONAL AND INTERNATIONAL CODES MUST BE FOLLOWED WHEN INSTALLING THE VENTILATION SYSTEM. ANY APPLICABLE CODES SUPERSEDE THE RECOMMENDATIONS SHOWN IN THIS MANUAL. IN AUSTRALIA COMPLIANCE TO REGULATIONS AS5601/AG601 IS MANDATORY.

The rate of air flow exhausted through the ventilation system may vary depending on the oven configuration and hood design. Consult the hood manufacturer or ventilation engineer for these specifications.

To avoid a negative pressure condition in the kitchen area, return air must be brought back to replenish the air that was exhausted. A negative pressure in the

kitchen can cause heat related problems to the oven components as if there were no ventilation at all. The best method of supplying return air is through the heating, ventilation, and air conditioning (HVAC) system. Through the HVAC system, the air can be temperature-controlled for summer and winter. Return air can also be brought in directly from outside the building, but detrimental effects can result from extreme seasonal hot and cold temperatures from the outdoors.

NOTE: Return air from the mechanically driven system must not blow at the opening of the baking chamber. Poor oven baking performance will result.

C. Other Ventilation Concerns

- Special locations, conditions, or problems may require the services of a ventilation engineer or specialist.
- Inadequate ventilation can inhibit oven performance.
- It is recommended that the ventilation system and duct work be checked at prevailing intervals as specified by the hood manufacturer and/or HVAC engineer or specialist.

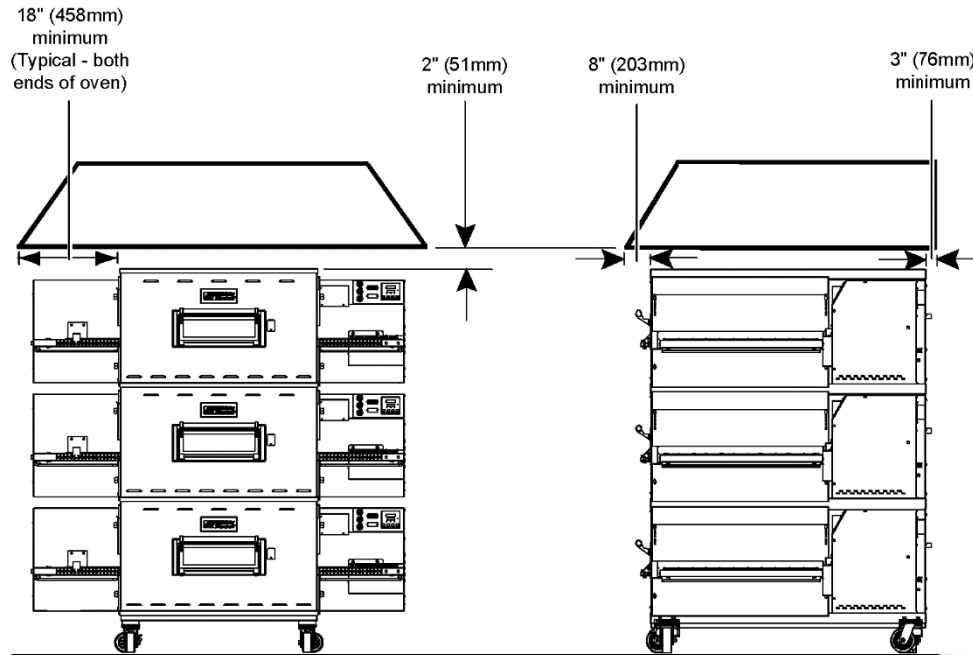

Figure 7. Ventilation System

III. ASSEMBLY

A. Top Panel and Base Pad Assembly

1. Install the four leg extensions onto the base pad using the 3/8"-16 x 1" screws, 3/8" flat washers, and 3/8" lockwashers supplied in the Base Pad Kit. See Figure 9. Check that the finished sides of each leg extension face OUTWARDS. One rear leg should be attached using three 3/8"-16 x 1" screws and the 3/4" eyebolt, as shown in Figure 9. This eyebolt acts as the anchor point for the restraint cable assembly (see Part C, Restraint Cable Installation).
2. If your oven is equipped with the lower shelf, position it in place as shown in Figure 9. Check that the lip on the shelf faces DOWN. Seal joint between leg and shelf with NSF listed silicone.
3. Install one caster onto each leg extension, as shown in Figure 8. Use the 3/8"-16 x 1" screws, 3/8" flat washers, and 3/8" lockwashers supplied in the Installation Kit. The locking casters (if equipped) should be installed at the FRONT of the oven. The non-locking casters should be installed at the REAR of the oven.
4. Install the lower oven cavity onto the base pad. See Figure 8.
5. For single ovens ONLY:

Install the top panel using the screws included in the base pad kit, as shown in Figure 10. Then, skip ahead to Part C, Restraint Cable Installation.

For double or triple ovens:

Continue on to Part B, Stacking. Note that the top panel should NOT be installed for double and triple ovens until after stacking the oven cavities.

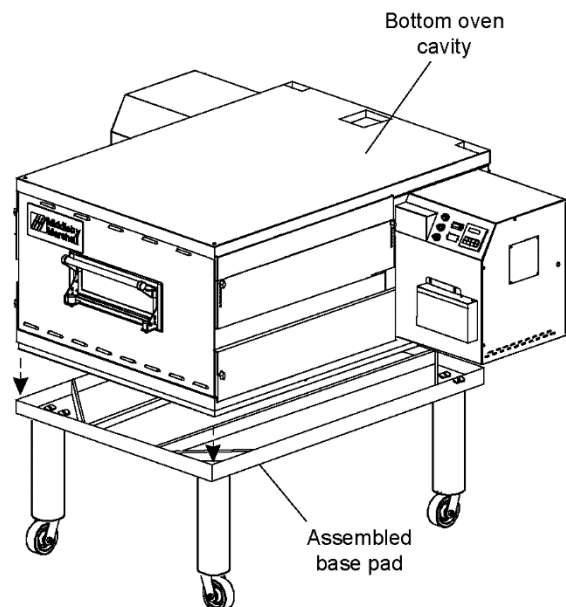

Figure 8. Base Pad Installation

SECTION 2
INSTALLATION

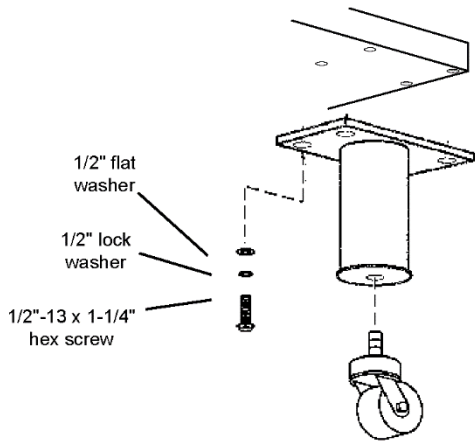

Figure 9. Leg Extension and Casters Installation

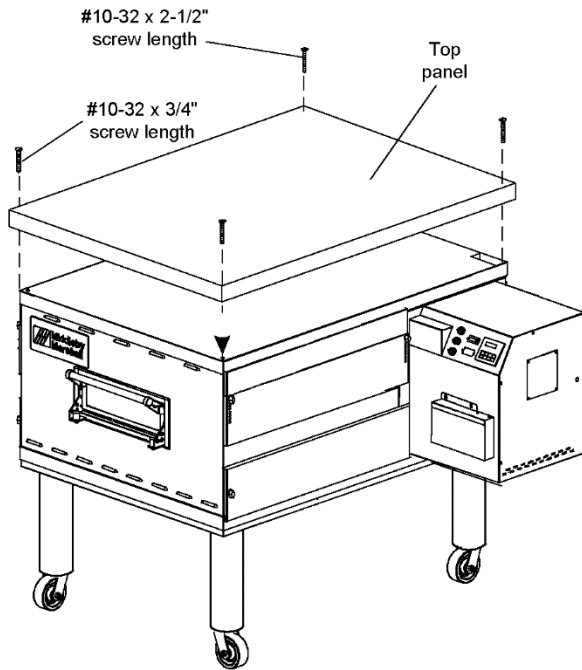

Figure 10. Top Panel Installation

NOTE: DO NOT install top panel onto double or triple ovens until AFTER stacking the oven cavities. See Part B, Stacking.

B. Stacking

For single ovens, skip ahead to Part C, Restraint Cable Installation.

IMPORTANT

Middleby Marshall **STRONGLY RECOMMENDS** that PS3240 Gas oven cavities be stacked **BY AUTHORIZED PERSONEL.**

Contact your Middleby Marshall Authorized Service Agent for complete stacking instructions.

1. Stack an oven cavity on top of the lower oven. Check the following:

- All four sides of the lower lip (on the bottom edge of the oven cavity) overlap the top of the lower oven.
- The oven is level.
- The oven is firmly seated.

See Figure 11.

2. For triple ovens, repeat Step 1 to install the top oven cavity.
3. Install the top panel using the screws included in the base pad kit, as shown in Figure 12.

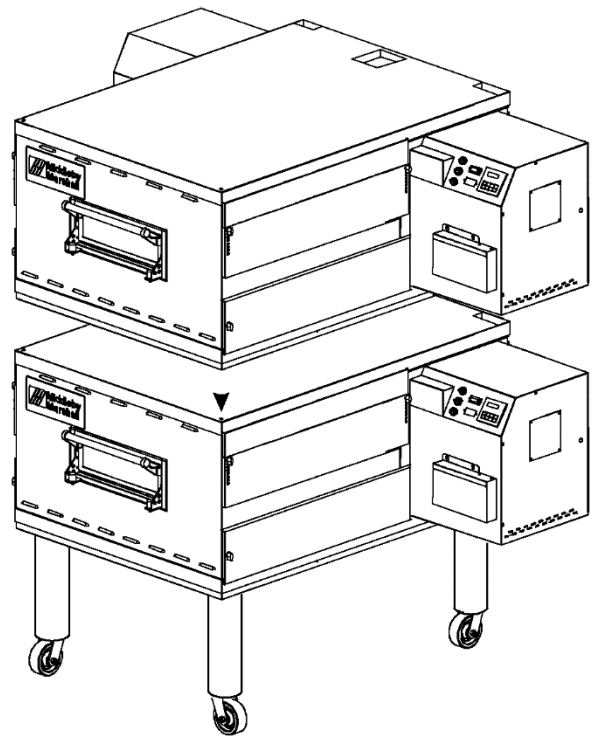

Figure 11. Stacking

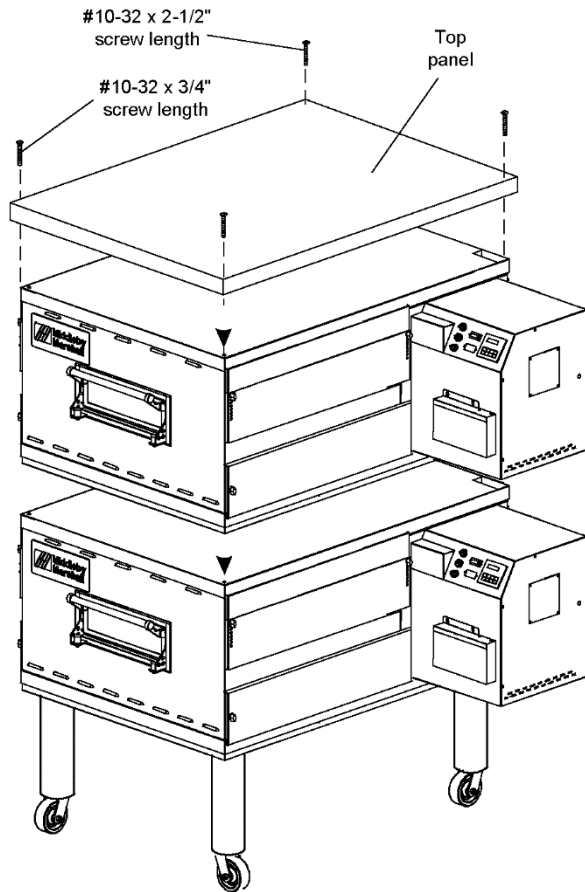

Figure 12. Top Panel Installation

C. Restraint Cable Installation

Because the oven is equipped with casters, a restraint cable assembly must be installed to limit the movement of the appliance without depending on the connector and the quick disconnect device or its associated piping. One end of the cable is anchored to the eyebolt on the rear surface of the oven's base pad, while the other is anchored to the wall. See Figure 13.

After connecting the restraint cable, move the oven to its final location. Adjust the bottom (hex) sections of the feet so that the casters are off the floor. For quad ovens, lock the two front casters.

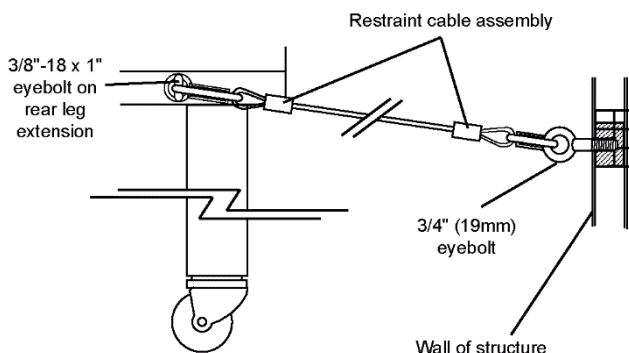

Figure 13. Installing the Restraint Cable

D. Conveyor Installation

1. Unfold the conveyor as shown in Figure 14. Then, begin to slide the conveyor into the end of the oven. The conveyor can only be installed from the end of the oven with the drive motor.
2. Continue moving the conveyor into the oven until the frame protrudes equally from each end of the oven. Check that the crumb tray supports located on the underside of the conveyor frame rest firmly against the lower end plugs, as shown in Figure 15.
3. When the conveyor is positioned properly, check for freedom of movement of the conveyor belt by pulling it for about 2-3 feet (0.6-1.0m) with your fingers. The drive and idler shafts must rotate smoothly, and the belt must move freely without rubbing on the inside of the oven.
4. Check the tension of the conveyor belt as shown in Figure 16. The belt should lift about 1" (25mm). **DO NOT OVERTIGHTEN THE CONVEYOR BELT.**

NOTE: If necessary, the belt tension can be adjusted by turning the conveyor adjustment screws, located at the idler (non-control) end of the conveyor. See Figure 16.

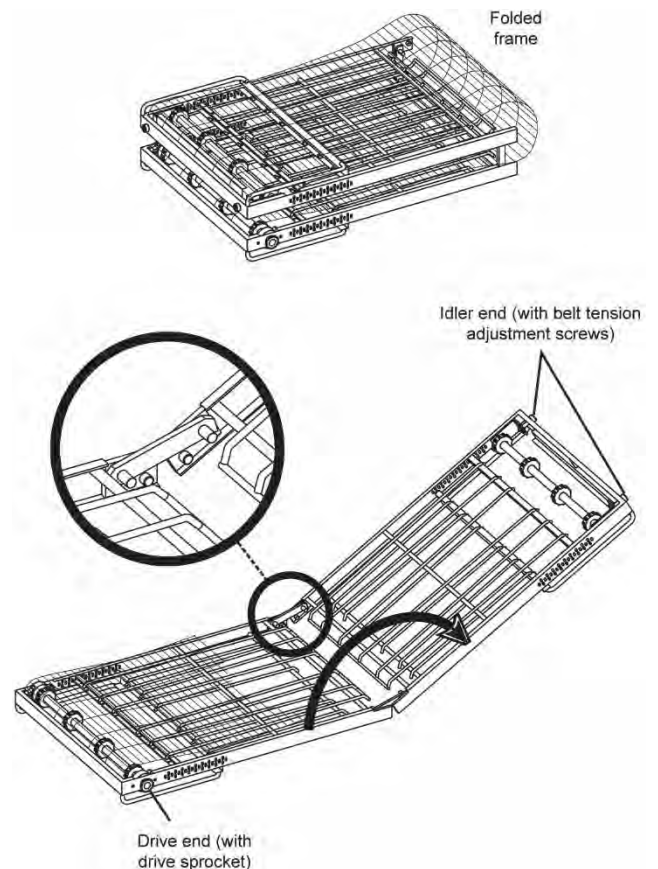

Figure 14. Conveyor Installation

**SECTION 2
INSTALLATION**

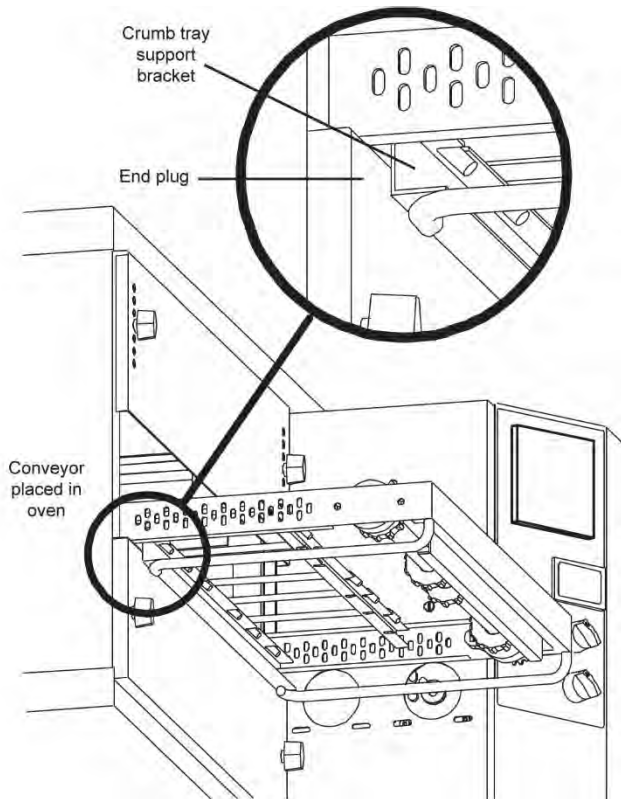

Figure 15. Conveyor Placement

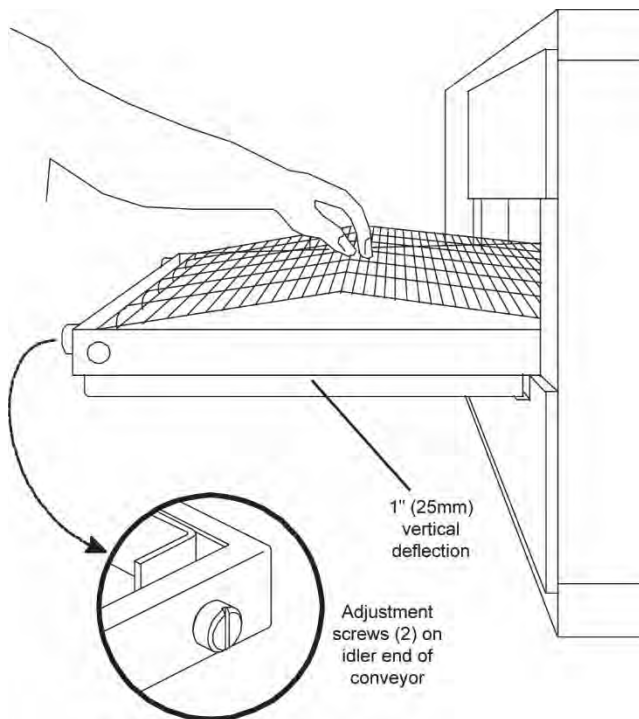

Figure 16. Conveyor Belt Tension

5. If it is necessary to add or remove conveyor links to achieve the correct tension, OR if it is necessary to reverse the conveyor belt for correct orientation, the belt will need to be removed from the conveyor frame. If this is necessary, perform the following procedure:
 - a. Remove the conveyor assembly from the oven and place it flat on the floor.
 - b. Remove the master links using long-nose pliers. Then, roll up the belt along the length of the conveyor frame.
 - c. Add or remove belt links as necessary to achieve the correct belt tension.
 - d. Install the belt on the conveyor frame. Check that the conveyor belt links are oriented as shown in Figure 17, and that the smooth side of the conveyor belt faces UP.
 - e. Connect the inside master links. Check that the links are oriented as shown in Figure 17.
 - f. Connect the outside master links. Note that the outside master links each have an open hook on one side. This hook aligns with the hooks along the sides of the other conveyor links. See Figure 17.
 - g. Install the conveyor into the oven.

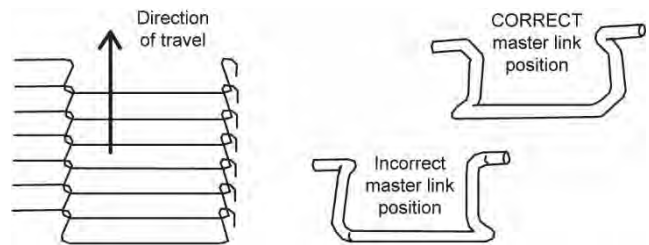

Figure 17. Conveyor and Master Link Orientation

E. Final Assembly

1. Install the crumb trays underneath the conveyor as shown in Figure 18.

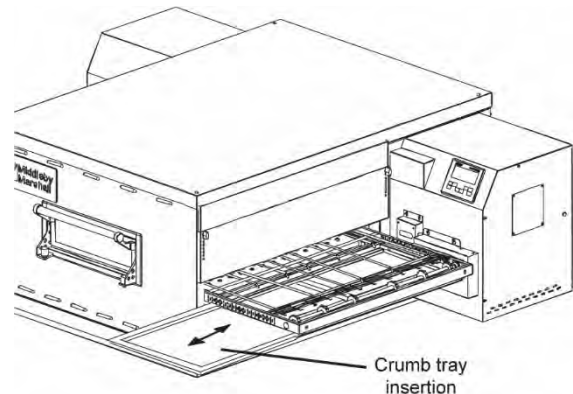

Figure 18. Crumb Trays

F. Conveyor Belt Reversal

Conveyor belt reversal consists of one step: Change the parameter on the Speed Control from 0001 to 0002.

To enter the programming mode: Press both the up and down arrow buttons and hold for three seconds. After approximately 3 seconds, the colon in the time will disappear. When the buttons are released, the program mode will commence. ***The program sequence will cycle automatically with each value***

available for change for approximately 8 seconds. Wait for the parameter of interest to appear, then use the up/down arrow to change the value.

Parameter 3 / dir: This lets the user set the motor to spin *Clockwise* or *Counterclockwise* (viewed from the motor end of the shaft). The default value is "1" (CCW) until the user changes the value. Set the value to "2" for CW rotation. The value will be saved after the user exits the programming sequence.

UTILITY ROUGH-IN FOR PS3240G-SERIES OVENS

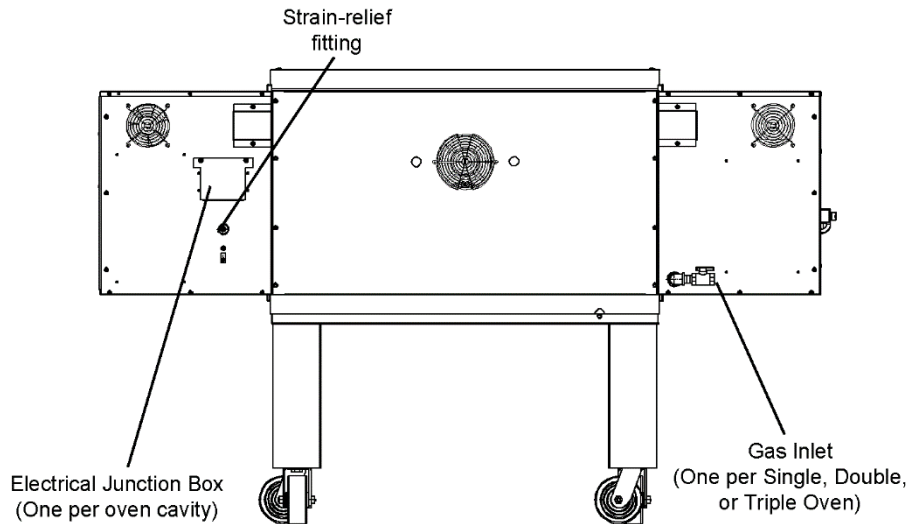

Figure 19. Utility Connection Locations for Gas Ovens

WARNING

Do not use conduit or gas line for ground connection.

CAUTION

It is recommended that the oven be placed under a ventilation hood for adequate air supply and ventilation.

IMPORTANT

Electric supply to be provided by customer.

WARNING

Authorized installation personnel normally accomplish the connections for the ventilation system, electric supply, and gas supply, as arranged by the customer. Following these connections, the factory-authorized installer can perform the initial startup of the oven.

IV. ELECTRICAL SUPPLY

NOTE: The electric supply installation must satisfy the requirements of the appropriate statutory authority such as the National Electrical Code, CSA C22.2; the Australian Code AG601; or other applicable regulations.

NOTE: The electric supply connection must meet all national and local electrical code requirements.

Check the oven serial plate before making any electric supply connections. Electric supply connections must agree with data on the oven serial plate. The location of the serial plate is shown in Figure 2 (in Section 1).

A fused disconnect switch or a main circuit breaker (customer furnished) **MUST** be installed in the electric supply line for each oven cavity. It is recommended that the switch/circuit breaker have Lockout/Tagout capability.

The supply conductors must be of the size and material (copper) recommended. Refer to the wiring diagram inside the machinery compartment of the oven. Electrical specifications are also listed on the oven's serial plate and in PS3240G Series Specifications in Section 1.

The oven requires a ground connection to the oven ground screw. For gas ovens, the screw is located in the electrical junction box (see Figure 7). If necessary, have the electrician supply the ground wire. Do **NOT** use the wiring conduit or other piping for ground connections.

Incoming electrical power lines are fed through the strain-relief fitting, shown in Figure 7. The electrical supply connections are made inside the electrical junction box. The power lines then connect to the oven circuits through safety switches located inside the machinery compartment and each blower motor compartment. These switches interrupt electrical power to the oven when the Machinery Compartment Access Panel is opened, OR when the rear panel is removed.

A. Electrical Connection

Refer to the wiring diagram inside the machinery compartment of the oven to determine the correct connections for the electrical supply lines. Connect the supply as indicated on the wiring diagram.

NOTICE

The terms of the oven's warranty require all start-ups, conversions and service work to be performed by a Middleby Marshall Authorized Service Agent.

V. GAS SUPPLY

The following gas system specifications are **STRONGLY RECOMMENDED**. Deviating from these recommendations may affect the baking performance of the oven.

Gas Meter

- One or two cavities: 750 cfh meter
- Three oven cavities: 1200 cfh meter

Gas Line

- DEDICATED LINE from the gas meter to the oven
- 2" (50.8mm) pipe for natural gas
- 2" (50.8mm) pipe for propane
- Maximum length: 200' (61m). Each 90° elbow equals 7' (2.13m) of pipe.

Check the oven's gas supply requirements before making the gas utility connection. Gas supply requirements are listed on the oven's serial plate and in PS3240G Series Specifications in Section 1.

Check the serial plate to determine the type of gas (Propane or Natural) to be used with the oven.

NOTICE

Where national or local codes require the installation of fire suppression equipment or other supplementary equipment, **DO NOT** mount the equipment directly to the oven.

Mounting such equipment may:

- Void agency certifications
- Restrict service access
- Lead to increased service expenses for the owner

A. Gas Connection

CAUTION

DURING PRESSURE TESTING NOTE THE FOLLOWING:

- 1. The oven and its individual shutoff valve must be disconnected from the gas supply piping system during any pressure testing of that system at test pressure in excess of 1/2 psi (3.45kPa).**
- 2. The oven must be isolated from the gas supply piping system by closing its individual manual shutoff valve during any pressure testing of the gas supply piping system at test pressure equal to or less than 1/2 psi (3.45kPa).**
- 3. If incoming pressure is over 14" W.C. (35mbar), a separate regulator MUST be installed in the line BEFORE the individual shutoff valve for the oven.**

NOTICE

To prevent damage to the control valve regulator during initial turn-on of gas, it is very important to open the manual shutoff valve very slowly.

After the initial gas turn-on, the manual shutoff valve must remain open except during pressure testing as outlined in the above steps or when necessary during service maintenance.

Refer to the instructions in the gas hose package (included in the Installation Kit) before connecting the gas line. One gas line connection method is shown in Figure 20; however, compliance with the applicable standards and regulations is mandatory.

Inlet, regulated, and pilot gas pressure readings can be taken using a digital tube manometer at the tap location shown in Figure 21. Figure 21 shows the burner assembly and Figure 23 shows the gas valve.

NOTE: The installation must conform with local codes or in the absence of local codes, with the National Fuel Gas Code, ANSI Z223.1-latest edition.

Certain safety code requirements exist for the installation of gas ovens; refer to the beginning of Section 2 for a list of the installation standards. In addition, because the oven is equipped with casters, the gas line connection shall be made with a connector that complies with the Standard for Connectors for Movable Gas Appliances, ANSI Z21.69 (in U.S.A.), as well as a quick-disconnect device that complies with the Standard for Quick-Disconnect Devices for Use With Gas Fuel, ANSI Z21.41 (in U.S.A.).

SECTION 2 INSTALLATION

B. Gas Conversion

Where permitted by local and national codes, it is possible to convert ovens from natural to propane gas, or from propane to natural gas. Use the appropriate Middleby Gas Conversion Kit for the specific oven model.

NOTICE

The terms of the oven's warranty require all startups, conversions and service work to be performed by a Middleby Authorized Service Agent.

C. PS3240 Propane Conversion

Two items have to be changed, to change the oven to LP:

1. Replace main orifices.
2. Adjust main gas regulator per instructions below.

Disconnect the manifold union closest to the main burner, and remove the manifold assembly (four screws). Slide out the manifold assembly (leaving the ignition and sense wires connected). Replace the main orifices.

Replace the main orifices on the manifold assemblies with the LP units, and replace the manifold assembly. Reconnect the union. Make sure there are no gas leaks.

D. Adjusting the Maximum Pressure Setting

1. Disconnect pressure feedback connection (if applicable).
2. Connect a digital pressure manometer to the gas manifold (Figure 21) to measure burner pressure (measuring point must be as near to burner as possible).

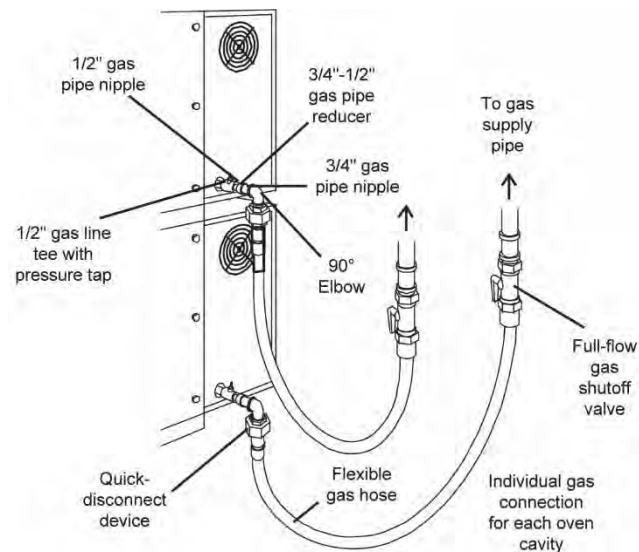

Figure 20. Flexible Gas Hose Installation

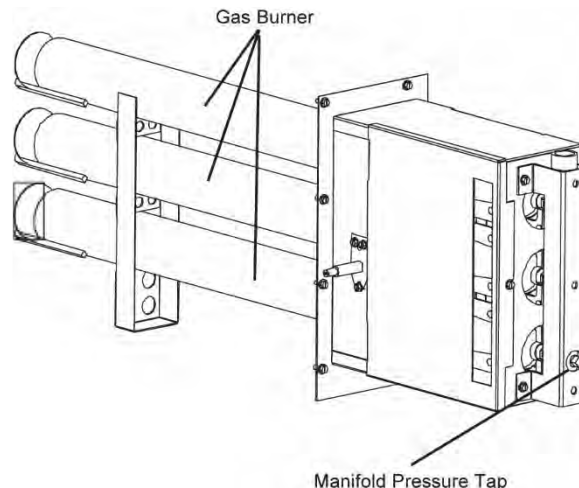

Figure 21. Gas Burner Assembly

3. Make sure that the appliance is in operation and the Moduplus® coil is energized with maximum current.
4. Place a 5mm wrench on the minimum adjustment screw and hold in place while making maximum pressure adjustments.
5. If maximum rate pressure needs adjustment, use an 8mm wrench to turn adjustment screw for maximum pressure setting (clockwise to increase or counter-clockwise to decrease pressure), until the desired maximum outlet pressure is obtained.
6. Disconnect electrical connection of the Moduplus®.
7. Check minimum pressure setting and readjust if necessary. (See Adjusting Minimum Pressure Setting for proper adjusting procedure.)
8. If minimum and maximum pressures are set, wire the Moduplus® in circuit.
9. Close pressure tap screw.

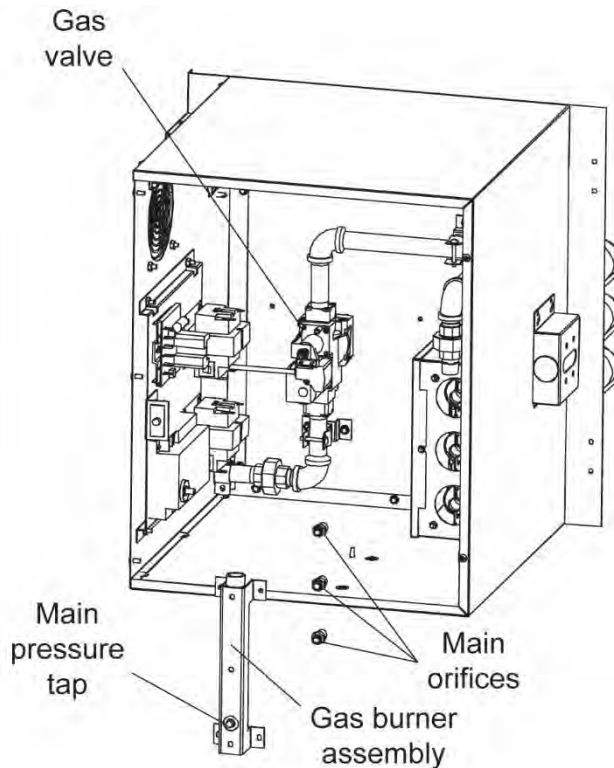

Figure 22. Burner Assembly

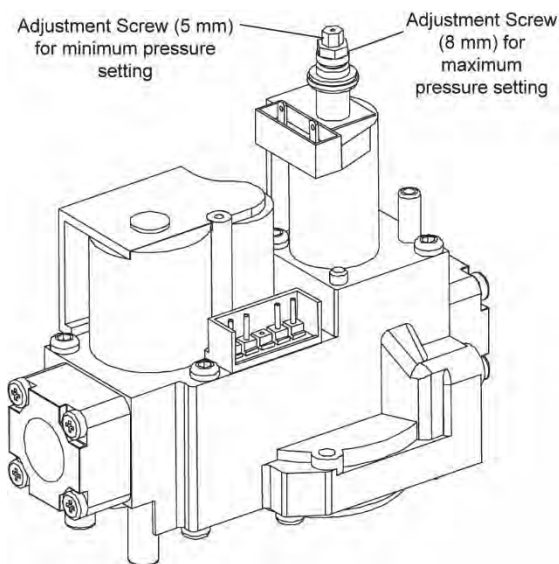

Figure 23. Gas Valve

E. Adjusting the Minimum Pressure Setting

1. Disconnect pressure feedback connection (if applicable).
2. Connect a digital pressure manometer to the gas manifold (Figure 21) to measure burner pressure (measuring point must be as near to burner as possible).

3. Disconnect electrical connection of the Moduplus®.
4. Make sure the appliance is in operation and the Moduplus coil is not energized.
5. Place an 8mm wrench on the maximum adjustment screw and hold in place while making minimum pressure adjustments.
6. If minimum rate pressure needs adjustment, use a 5mm wrench to turn adjustment screw for minimum pressure setting (clockwise to increase or counter-clockwise to decrease pressure), until the desired minimum outlet pressure is obtained.
7. Check if main burner lights easily and reliable at minimum pressure.
8. Close pressure tap screw.

F. Checkout

After any adjustment, set appliance in operation and observe through a component cycle to ensure that burner system components function correctly.

NOTE: The installer MUST verify oven operation prior to putting oven into service.

G. Maintenance

It is recommended to check yearly the minimum and the maximum setting and readjust them if necessary.

SECTION 3 OPERATION

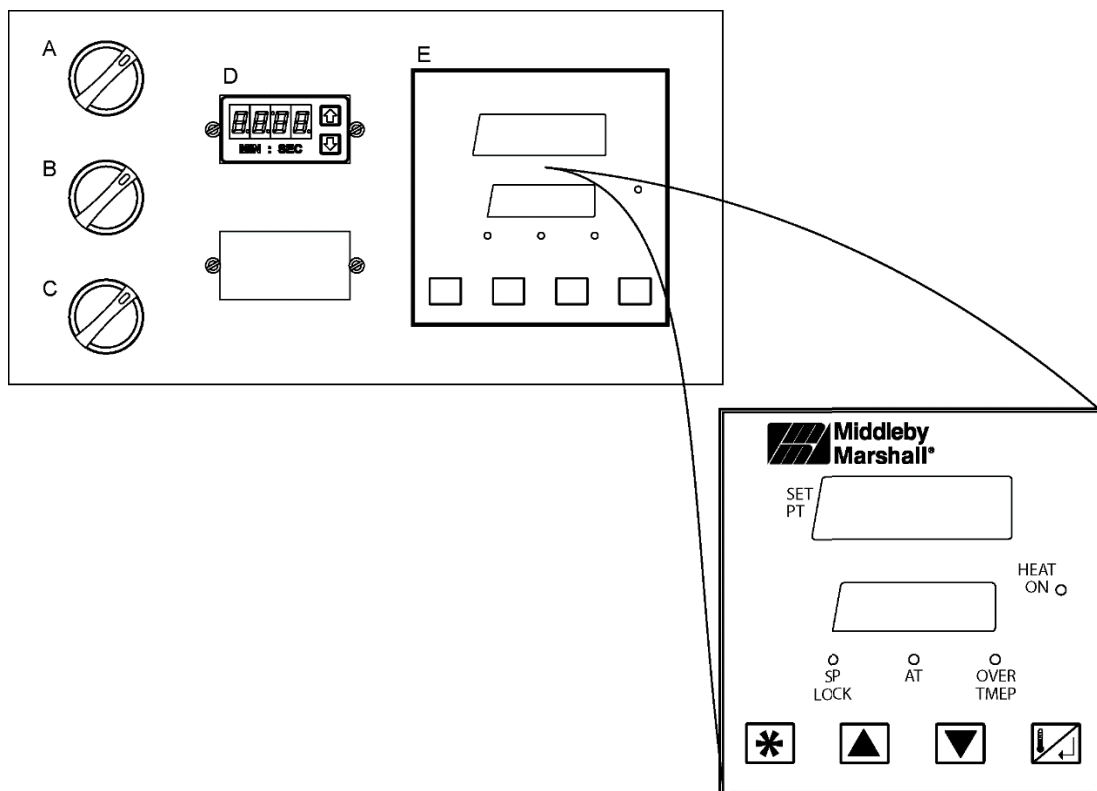

Figure 24. Control Panel

I. LOCATION AND DESCRIPTION OF CONTROLS

A. “BLOWER” Switch



Turns the blowers and cooling fans on and off. The HEAT Switch has no effect unless the BLOWER Switch is in the “ON” position.

B. “HEAT” Switch



Allows the burner to activate. Activation is determined by the settings on the Digital Temperature Controller.

C. “CONVEYOR” Switch



Turns the conveyor drive motor on and off.

D. Conveyor Speed Controller



Adjusts and displays the bake time. Single-belt ovens have one controller. Split belt ovens have one controller for each conveyor belt, labeled “FRONT” and “BACK”.

E. Digital Temperature Controller



Continuously monitors the oven temperature. Settings on the Digital Temperature Controller control the activation of the burner. Keypad controls allow the operator to select the cooking temperature and monitor oven operation.

F. Machinery and Control Compartment Safety Switches (*NOT SHOWN*)

Disconnect electrical power to the controls and blowers when EITHER the machinery compartment door OR the control compartment door is opened. The doors should only be opened by authorized service personnel.

SECTION 3
OPERATION

II. STEP-BY-STEP OPERATION

A. Daily Start-up Procedure

1. Check that the circuit breaker/fused disconnect is in the on (closed) position. Check that the window is closed.

2. Turn the BLOWER switch to the "ON" or "I" position.

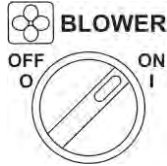

3. Turn the CONVEYOR switch to the "ON" or "I" position.

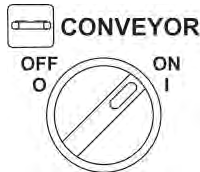

4. If necessary, adjust the conveyor speed setting by using the up and down arrow buttons on the Speed Controls.

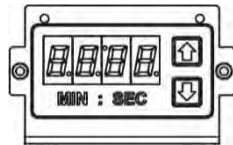

5. Verify the temperature controller's set point for baking and adjust if necessary:

- The set point appears in the upper display.
- Adjusting the set point requires a "Set Point Only" display, where nothing is in the lower display. To get to "Set Point Only", press the Scroll key until the lower display is blank.
- From this "Set Point Only" display, use the up and down keys to adjust the temperature. Holding in the pressed key will adjust at a faster rate.

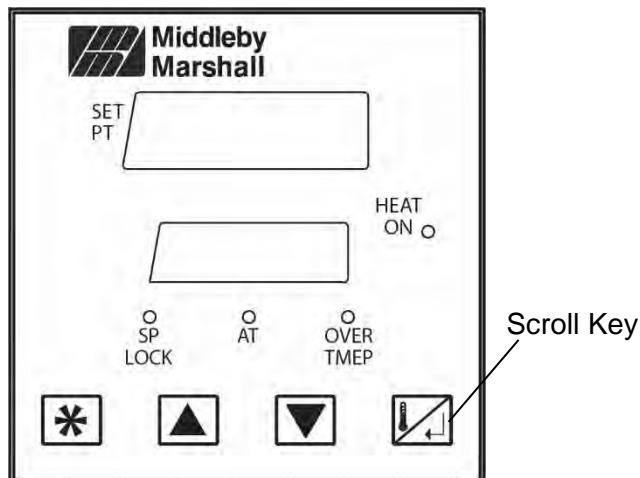

6. Turn the HEAT switch to the "ON" or "I" position. The HEAT ON LED lights to show that the oven is heating.



IMPORTANT

On gas ovens, if the HEAT ON LED does not light, OR if the oven does not heat, the gas burner may not have lit. Turn the HEAT, BLOWER, and CONVEYOR switches to the "OFF" ("O") position. WAIT FOR AT LEAST FIVE MINUTES before restarting the oven. Then, restart the Daily Start-up procedure.

7. With the HEAT ON LED lit, press the Scroll key one time from the "Set Point Only" display. The actual temperature will appear in the lower display.

8. Wait while the actual temperature reaches the set point. Higher set point temperatures will require a longer wait. The oven can reach a temperature of 500°F (232°C) in approximately 15 minutes.

9. After the actual temperature has reached the set point, allow the oven to preheat for 10 more minutes to stabilize the temperature.

B. Daily Shutdown Procedure

1. Turn the BLOWER and HEAT switches to the "OFF" or "O" position. The blowers will remain in operation until the oven has cooled to below 200°F (93°C).

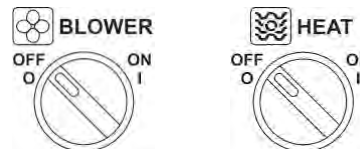

2. Make sure there are no products left on the conveyor inside the oven.

3. Turn the CONVEYOR switch to the "OFF" or "O" position.

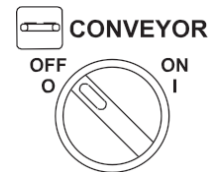

4. Open the window to allow the oven to cool faster.

5. After the oven has cooled and the blowers have turned off, switch the circuit breaker/fused disconnect to the "OFF" position.

C. Power Failure

In case of power failure, turn all switches to the "OFF" ("O") position, open the oven window, and remove the product. After the power has been restored, perform the normal start-up procedure. If HEAT was switched off for less than 5 minutes, WAIT FOR AT LEAST FIVE MINUTES before restarting the oven.

NOTICE

The burner will not operate and gas will not flow through the burner without electric power. No attempt should be made to operate the oven during a power failure.

III. TEMPERATURE CONTROLLER OPERATION

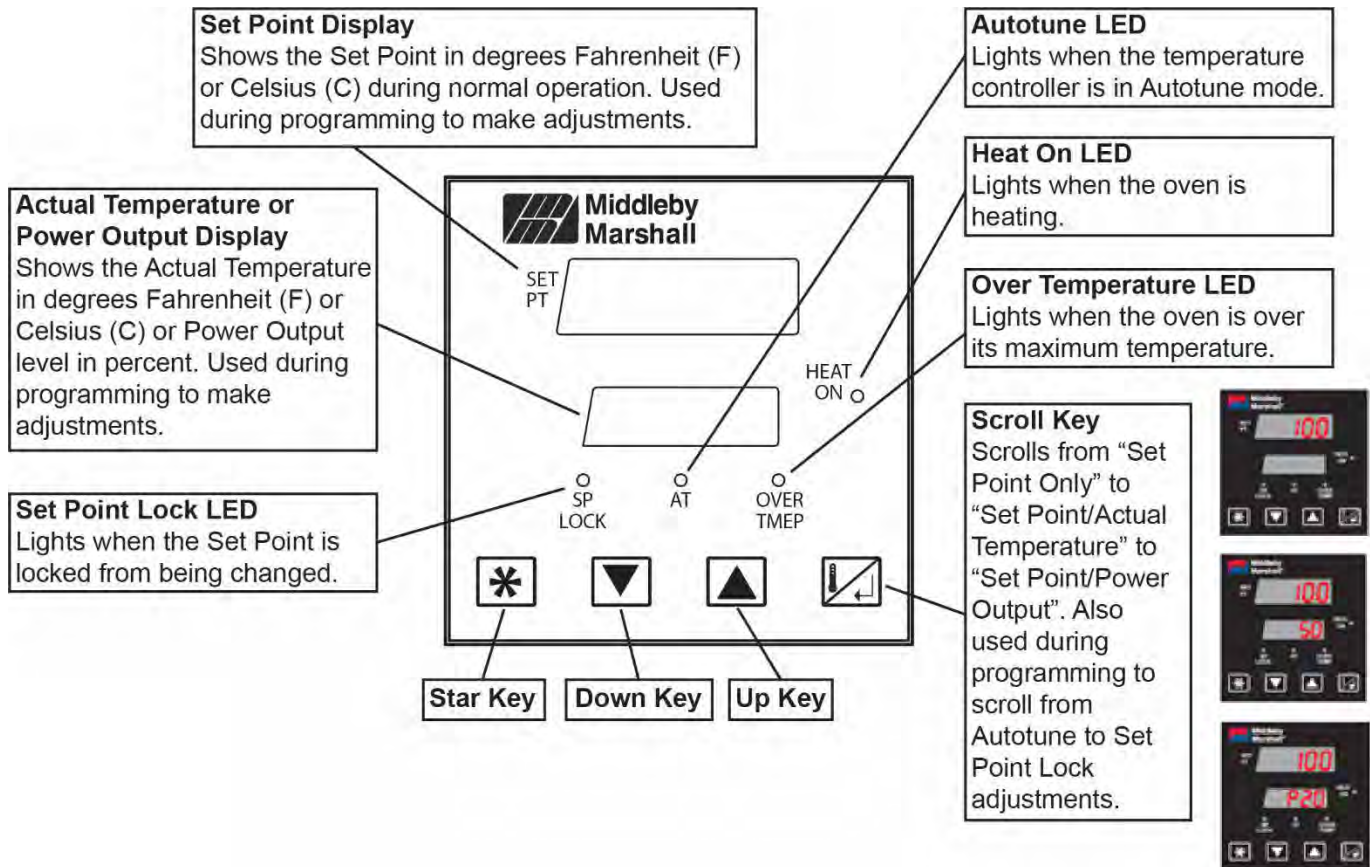

NOTE: After 1 minute of no key activity, the controller will go to "Set Point Only" with the lower display blank.



A. Operation Adjustments

Adjusting the Set Point

The set point appears in the upper display and can only be adjusted when the lower display is blank. Press the Scroll key until you reach this "Set Point Only" display. Use the Up and Down keys to adjust the temperature. Holding in the pressed key will adjust at a faster rate.

Adjusting for °F/°C

Press the Up and Down keys together for 3 seconds. The units will switch between Fahrenheit and Celsius.

B. Programming Adjustments

Adjusting Power Output

Press the Star and Up keys together for 3 seconds. The display shows "PXX", where "XX" is the percent of power output. Use the Up and Down keys to adjust the percent, then press the Star and Up keys together for 3 seconds to exit.

Locking and Unlocking Set Point



The Set Point can be locked so that it isn't changed during operation. Press the Star key for 3 seconds, then use the Scroll key to choose Set Point Lock. Use the Up and Down keys to turn the Set Point Lock on and off. Press the Star key for 3 seconds to exit.

SECTION 4 MAINTENANCE

WARNING

Before ANY cleaning or servicing of the oven, perform the following procedure:

6. Switch off the oven and allow it to cool. Do NOT service the oven while it is warm.
7. Turn off the electric supply circuit breaker(s) and disconnect the electric supply to the oven.
8. If it is necessary to move a gas oven for cleaning or servicing, disconnect the gas supply before moving the oven.

When all cleaning and servicing is complete:

1. If the oven was moved for servicing, return the oven to its original location.
2. If the restraint cable was disconnected to clean or service the oven, reconnect it at this time.
3. Reconnect the gas supply.
4. Reconnect the electrical supply.
5. Turn on the full-flow gas safety valve. Test the gas line connections for leaks using approved leak test substances or thick soap suds.
6. Turn on the electric supply circuit breaker(s).
7. Perform the normal start-up procedure.

WARNING

Possibility of injury from rotating parts and electrical shock exist in this oven. Switch off and lockout/tagout the electric supply BEFORE beginning to disassemble, clean, or service any oven. Never disassemble or clean an oven with the BLOWER switch or any other circuit of the oven switched on.

NOTICE

NEVER use a water hose or pressurized steam-cleaning equipment when cleaning this oven. To avoid saturating the oven insulation, DO NOT use excessive amounts of water. DO NOT use a caustic oven cleaner, which can damage the bake chamber surfaces.

NOTICE

ANY replacement parts that require access to the interior of the oven may ONLY be replaced by a Middleby Marshall Authorized Service Agent. It is also strongly recommended that the 3-Month Maintenance and 6-Month Maintenance procedures in this section be performed ONLY by a Middleby Marshall Authorized Service Agent.

I. MAINTENANCE - DAILY

1. Check that the oven is cool and the power is disconnected, as described in the warning at the beginning of this section.
2. Clean ALL of the cooling fan grills and vent openings with a stiff nylon brush. Refer to Figure 25 for the locations of the grills and vents.
3. Clean the outside of the oven with a soft cloth and mild detergent.
4. Check that ALL cooling fans are operating properly.

NOTICE

If a cooling fan is not operating correctly, it must be replaced IMMEDIATELY. Operating the oven without adequate cooling can seriously damage the oven's internal components.

5. Clean the conveyor belts with a stiff nylon brush. This is more easily accomplished by allowing the conveyor to run while you stand at the exit end of the conveyor. Then, brush the crumbs off the conveyor as it moves.
6. Remove and clean the crumb trays. If necessary, refer to Figure 18 (in Section 2, Installation) when replacing the crumb trays into the oven.
7. Clean the window in place.

SECTION 4
MAINTENANCE

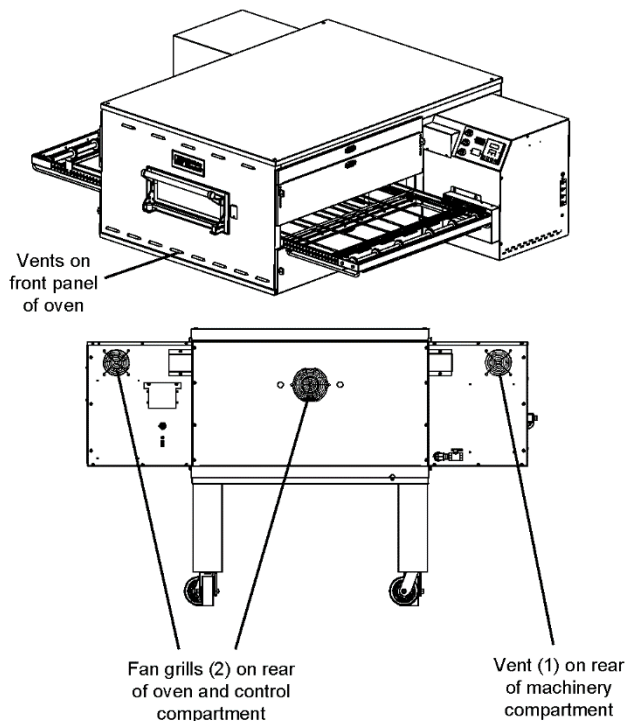

Figure 25. Cooling Vents and Grills

II. MAINTENANCE - MONTHLY

NOTE: When removing the conveyor, refer to Figure 14 (in Section 2, Installation).

1. Check that the oven is cool and the power is disconnected, as described in the warning at the beginning of this section.
2. Remove the crumb trays from the oven.
3. Lift the drive end of the conveyor slightly, and push it forward into the oven. This removes the tension from the drive chain. Then, remove the drive chain from the conveyor sprocket.
4. Slide the conveyor out of the oven, folding it as it is removed.
5. Remove the end plugs from the oven. The end plugs are shown in Figure 2 (in Section 1, Description).
6. Slide the air fingers and blank plates out of the oven, as shown in Figure 26. AS EACH FINGER OR PLATE IS REMOVED, WRITE A "LOCATION CODE" ON IT WITH A MARKER to make sure that it can be reinstalled correctly.

Example of markings:

(Top Row)	T1	T2	T3	T4	T5	T6
(Bottom Row)	B1	B2	B3	B4	B5	B6

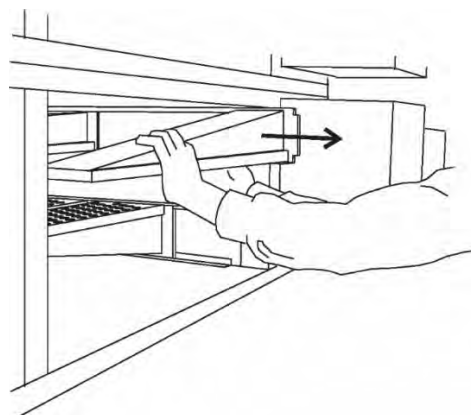

Figure 26. Removing Air Fingers and Plates

7. Disassemble the air fingers as shown in Figure 27. AS EACH FINGER IS DISASSEMBLED, WRITE THE "LOCATION CODE" FOR THE FINGER ON ALL THREE OF ITS PIECES. This will help you in correctly reassembling the air fingers.

NOTICE

Incorrect reassembly of the air fingers will change the baking properties of the oven.

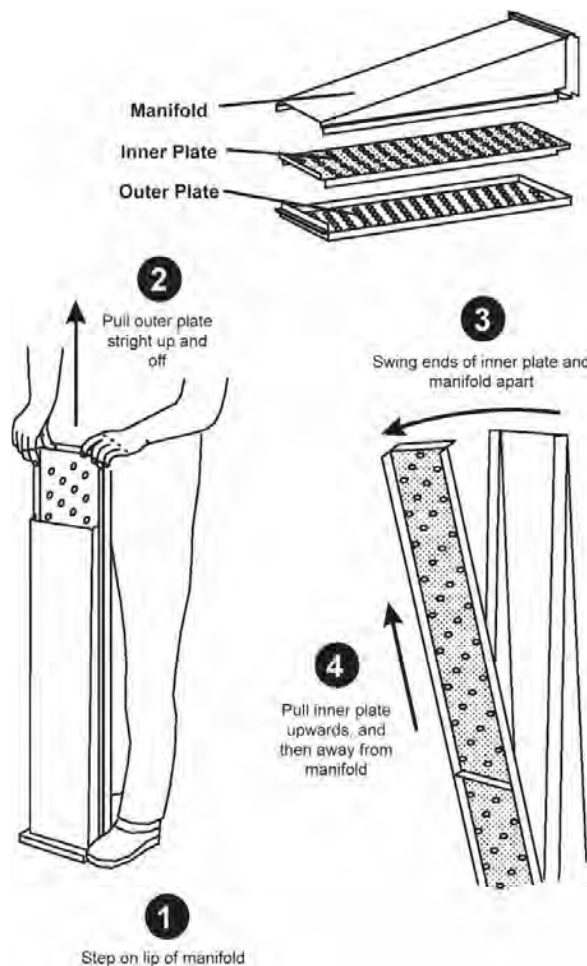

Figure 27. Disassembling the Air Fingers

8. Clean the air finger components and the interior of the baking chamber using a vacuum cleaner and a damp cloth. Refer to the boxed warnings at the beginning of this section for cleaning precautions.
9. Reassemble the air fingers. Then, replace them in the oven, using the "location guide" as a guide.
10. Replace the end plugs on the oven.
11. Reassemble the conveyor into the oven. If the drive sprocket was removed when installing the conveyor, replace it at this time.
12. Reattach the drive chain.
13. Check the tension of the conveyor belt as shown in Figure 16 (in Section 2, Installation). The belt should lift between 3 - 4" (75-100mm). **DO NOT OVERTIGHTEN THE CONVEYOR BELT.** If necessary, the belt tension can be adjusted by turning the conveyor adjustment screws, located at the idler (right) end of the conveyor.
14. Replace the crumb trays.

III. MAINTENANCE - EVERY 3 MONTHS

1. Check that the oven is cool and the power is disconnected, as described in the warning at the beginning of this section.
2. Vacuum both of the blower mounts, and their surrounding compartments, using a shop vacuum.
3. Tighten all electrical terminal screws.

A. Split Belt Disassembly and Cleaning

1. Refer to Part D, Conveyor Installation, in the Installation section of this manual. Then, remove the following components from the oven:
 - Conveyor end stop
 - Crumb trays
 - Chain cover
 - Drive chains
 - End plugs
 - Conveyor assembly
2. Remove the master links from each conveyor belt. Then, roll the belts up along the length of the conveyor to remove them from the frame.
3. Remove the two conveyor adjustment screws from the idler end of the conveyor frame, as shown in Figure 28.
4. Remove the idler shaft assembly from the conveyor.
5. Pull apart the two sections of the idler shaft.

6. Clean the shafts thoroughly using a rag. Then, lubricate both the extended shaft and the interior of the hollow shaft using a light food-grade lubricant. **DO NOT** lubricate the shafts using WD40 or a similar product. This can cause the shafts to wear rapidly.
7. Before reassembling the shafts into the conveyor frame, check that they are oriented properly.

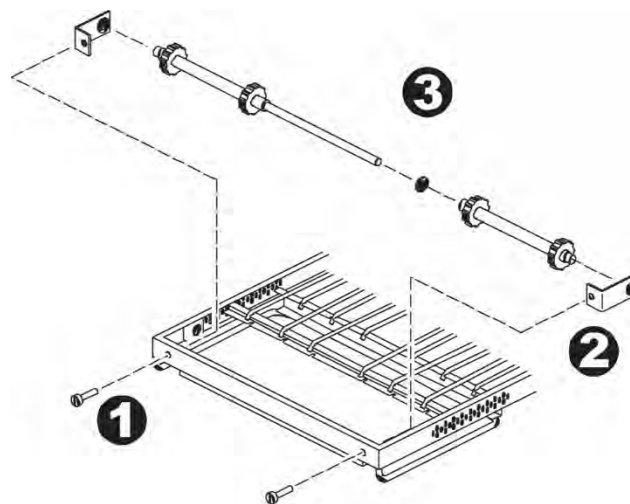

Figure 28. Disassembling the Idler Shaft

8. Reassemble the idler shaft into the conveyor. Make sure that the bronze washer is in place between the two sections of the shaft. See Figure 28.
9. Replace the conveyor adjustment screws as shown in Figure 28. To allow the conveyor belt to be reinstalled later, do not tighten the screws at this time.
10. Loosen the set screw on both of the conveyor drive sprockets. Then, remove the sprockets from the shaft.
11. Check the conveyor configuration as follows:

High-speed conveyors are equipped with large flange bearings at both ends of the shaft, as shown in Figure 29. For these conveyors, remove the two screws that hold each bearing to the conveyor frame. With the screws removed, lift the end of the shaft at the front of the oven, and pull the entire assembly free of the conveyor frame.

Standard conveyors are equipped with bronze bushings mounted on spacers at both ends of the shaft, as shown in Figure 29. For these conveyors, remove the two screws that hold the bracket to the conveyor frame. With the screws removed, lift the end of the shaft at the front of the oven, and pull the entire assembly free of the conveyor frame. The brackets will be removed along with the drive shaft assembly.

SECTION 4 MAINTENANCE

12. Disassemble and lubricate the two sections of the drive shaft as described for the idler shaft, above.
13. Before reassembling the shafts into the conveyor frame, check that they are oriented properly.
14. Reassemble the drive shaft into the conveyor. Make sure that the bronze washer is in place between the two sections of the shaft. See Figure 28.
15. Replace the drive sprockets. Reassemble the belts and master links onto the conveyor.
16. Reinstall the end plugs and conveyor onto the oven.
17. Reattach the drive chains. Replace the chain cover.
18. Check the tension of the conveyor belt as shown in Figure 16 (in Section 2, Installation). The belt should lift about 1" (25mm). If necessary, adjust the belt tension by turning the conveyor adjustment screws.
19. Replace all components onto the oven.

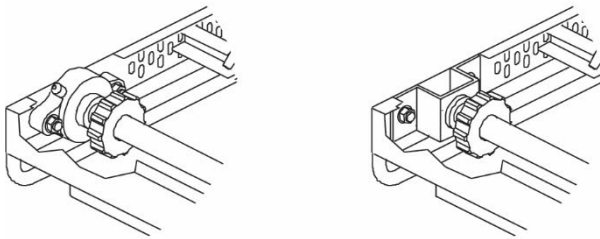

Figure 29. Drive Shaft Configurations

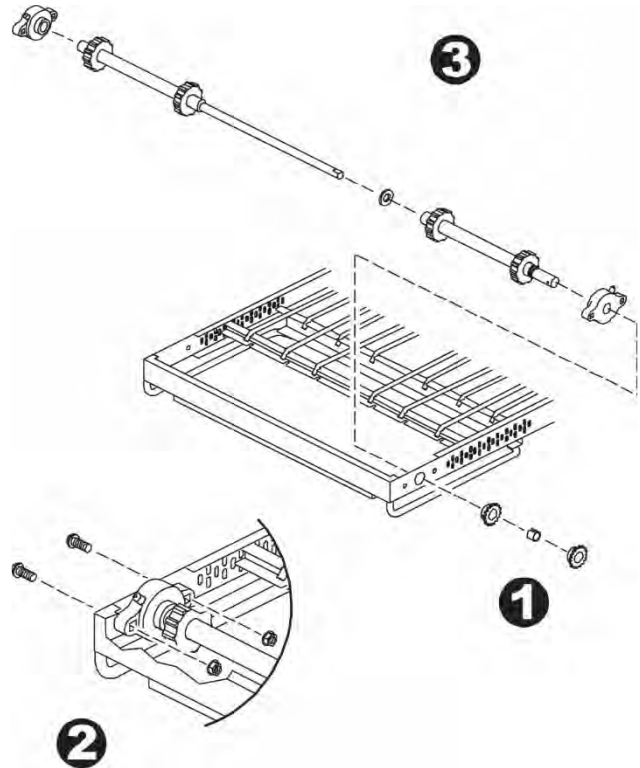

Figure 30. Disassembling the Drive Shaft

B. Blower Belt

1. Remove the eight screws shown in Figure 31. Then, remove the rear panel from the oven.
2. Check the blower belt for the proper 1/4" (6mm) deflection at the center, and for cracking or excessive wear.

See Figure 31. Overtightening the belt will cause premature bearing failure and possible vibrations. A loose belt may also cause vibrations.

3. If necessary, adjust the tension of the belt by loosening the four motor mounting bolts. Reposition the motor as necessary until the correct 1/4" (6mm) deflection is reached, then tighten the bolts.

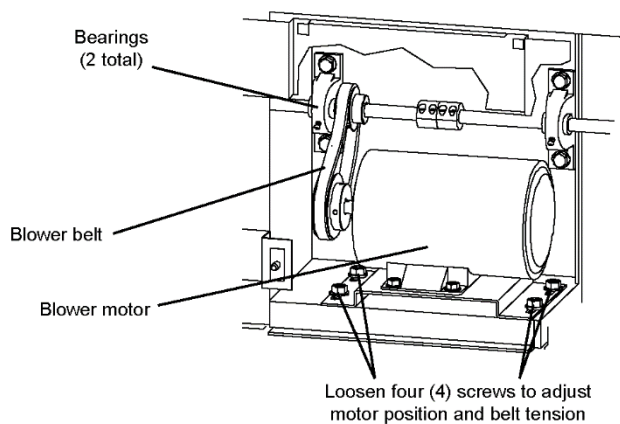
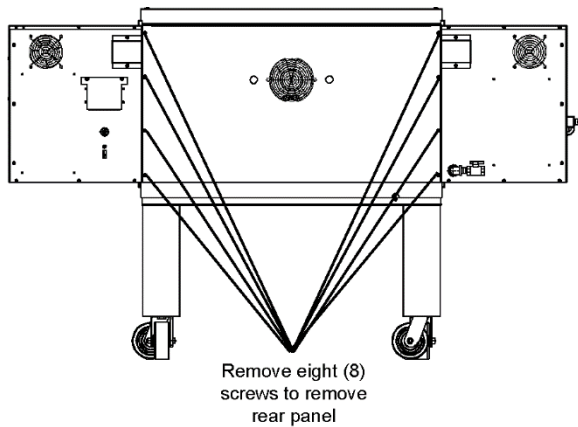

Figure 31. Rear Panel Access

IV. MAINTENANCE - EVERY 6 MONTHS

1. Check that the oven is cool and the power is disconnected, as described in the warning at the beginning of this section.
2. Check for excessive wear on the conveyor drive motor brushes. The brushes should be replaced if they have worn to less than 1/4" (6mm) in length. Be sure to replace the brushes in exactly the same position.
3. For gas ovens, inspect and clean the burner nozzle and the spark electrode assembly.
4. Check the conveyor drive shaft bushings and spacers. Replace the components if they are worn.

SECTION 4
MAINTENANCE

V. KEY SPARE PARTS

Replacement parts can be purchased from your Middleby Marshall Authorized Parts Distributor (See Figure 32).

PS3240G-SERIES GAS OVEN KEY SPARE PARTS (Figure 32)

ITEM	PART NO.	ENGLISH DESCRIPTION	QUANTITY
1	75729	Temperature Control	1
2	74106	Motor, Conveyor Drive	1
3	72533	Conveyor Speed Control	1
4	28041-0011	Contact, Motor	1
5	76979	Power Supply	1
6	33984	Kit, Thermocouple	2
7	65061	Fan Cooling Control	1
8	51399	Fan Cooling Rear	1
9	71421	Sensor, Hamlin 55100 Hall EFF	1
9a	77722	Board, Hall Relay	1
10	27381-0069	Motor, Blower	1
11	62285	Ignition Module & Ignition Cable	1
12	60679	Assy, Valve Gas Modulating	1
13	60671	Board, Signal Cond. 0-15VDC	1
14	33983	High Limit Control Module, 240V	1
15	32108	Transformer, 240Vp:24Vs	2
17	46521	Kit, Switch MM (Conveyor & Heat)	1
18	77949	Kit, Switch Double (Main On-Off)	1
20	71771	Relay, DPDT 24V Coil	1
21	68233	Belt, Blower	1
22	71037	Ignitor, Single Rod & Ignition Cable	1
24	64106	Bearing, PB 5/8 B	1

SECTION 4
MAINTENANCE

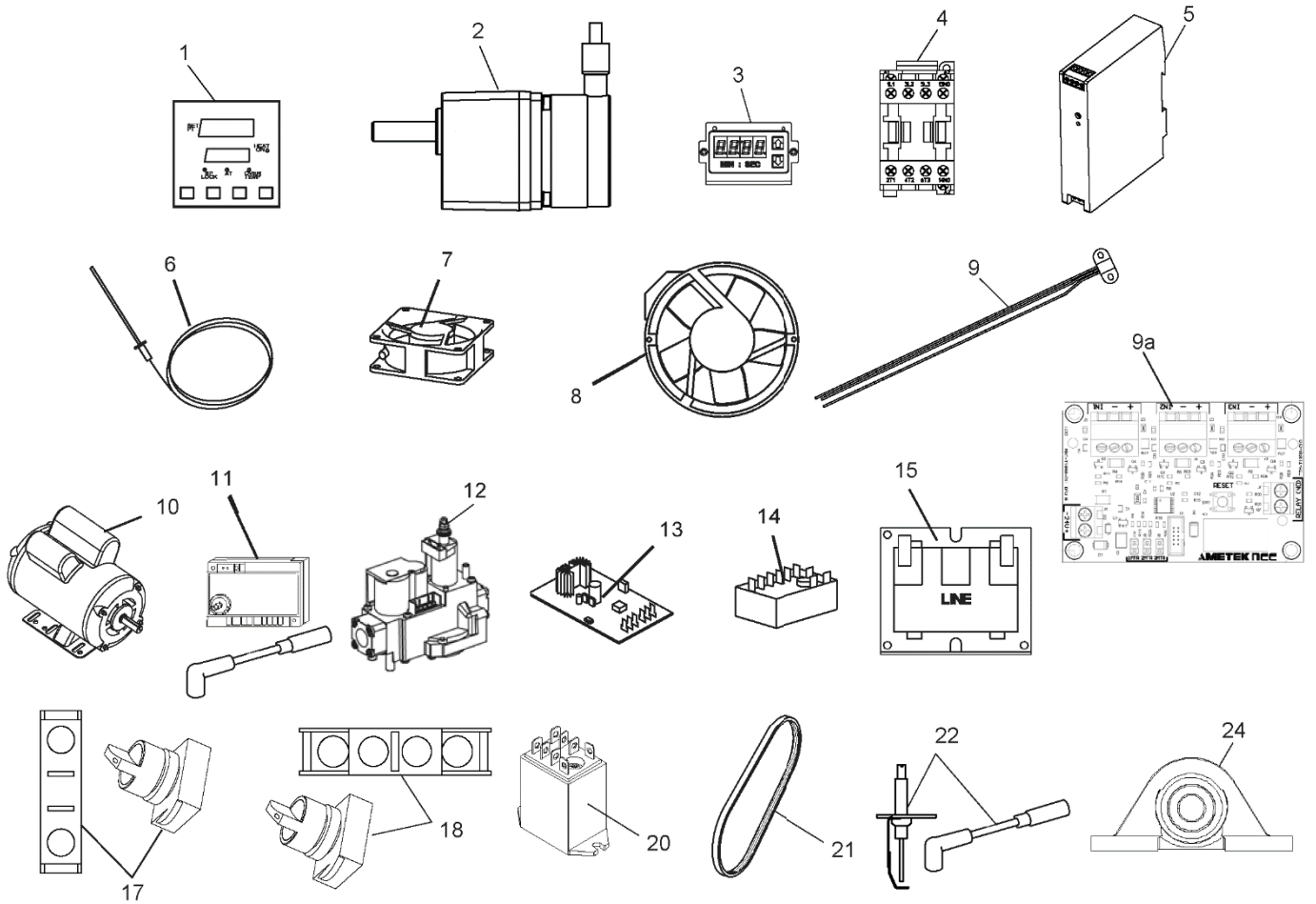

Figure 32.

SECTION 4
MAINTENANCE

NOTES

SECTION 5 TROUBLESHOOTING

QUICK REFERENCE

SYMPTOM	PROBLEM	SOLUTION
Oven will not turn on.	No electrical power	Check that the circuit breaker/fused disconnect is on. Make sure the emergency stop button is on.
Oven will not heat.	No gas pressure	Make sure main gas is on.
	Burner did not light.	Turn oven off, and restart. If it still does not light, call for service.
Oven is operating, but little or no air is coming from the fingers.	Air fingers may be assembled incorrectly after cleaning.	Turn oven off, and allow to cool. Reassemble fingers correctly.
Conveyor will not move.	Conveyor may be jammed.	Turn oven off, and allow to cool. Check conveyor for blockage.

SECTION 5
TROUBLESHOOTING

NOTES

SECTION 6 ELECTRICAL SCHEMATICS

Wiring Diagram, G208-240V 50/60 HZ • 77899 REV B

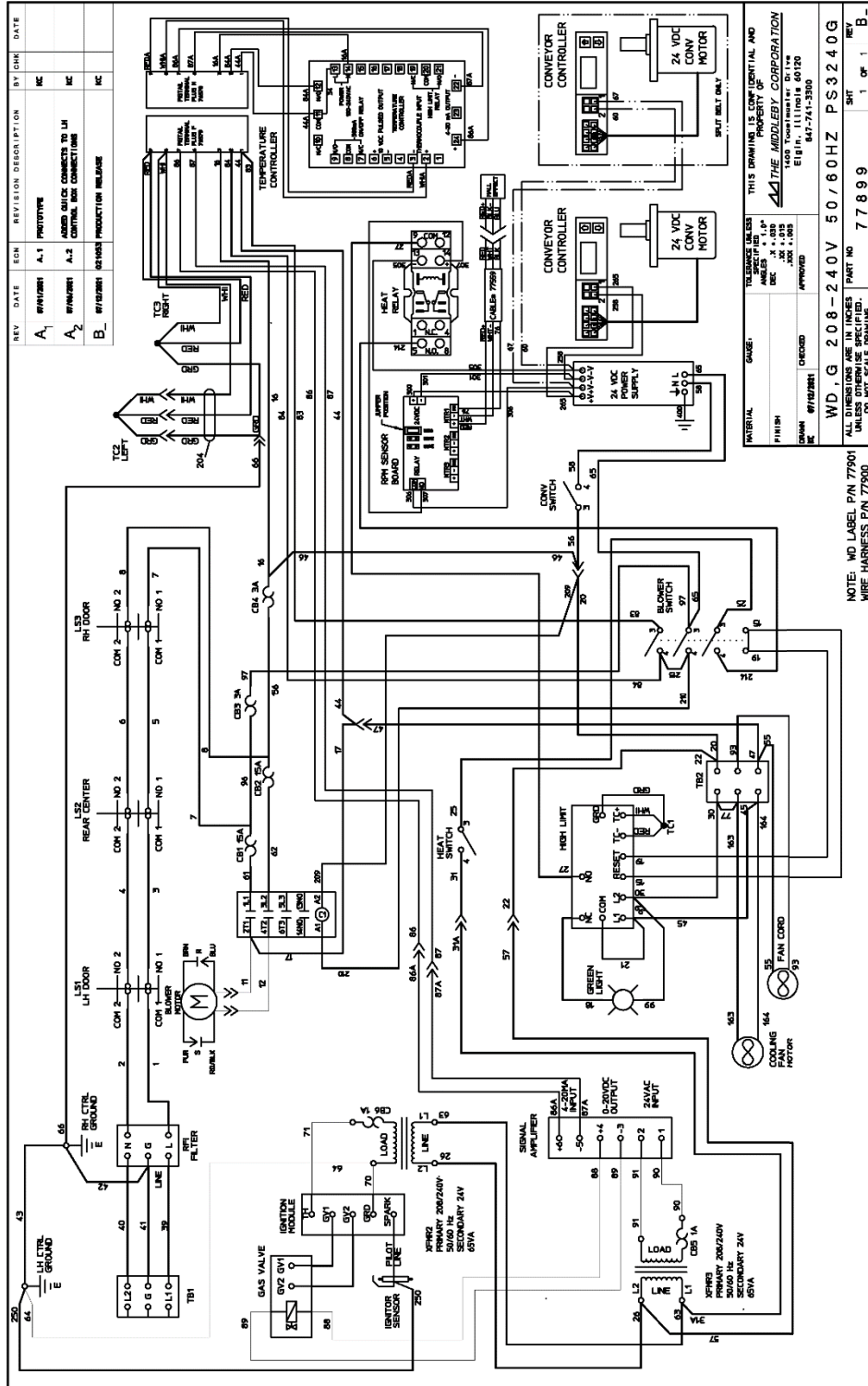

REV	DATE	EN	REVISION DESCRIPTION	BY	CHK	DATE
A ₁	8/19/2001	A.1	PROTOTYPE	MC		
A ₂	8/19/2001	A.2	ADDED QUICK CONNECTS TO LH CENTRAL BOX CONNECTIONS	MC		
B ₁	8/19/2001	B.1	ISSUE PRODUCTION RELEASE	MC		

RELEASED UNDER THIS DRAWING IS CONFIDENTIAL AND PROPERTY OF THE AMDEBY CORPORATION
 1400 Commonwealth Drive
 Elgin, Illinois 60120
 847-741-3500

DATE: 8/19/2001
 CHECKED: [Signature]
 APPROVED: [Signature]

WD.G 208-240V 50/60HZ PS3240G
 PART NO. 77899
 1 OF 1

NOTE: NO LABEL FOR 77901
 ALL DIMENSIONS ARE IN INCHES
 UNLESS OTHERWISE SPECIFIED
 WIRE HARNESS FOR 77900

WARNING

Improper installation, adjustment, alteration, service or maintenance can cause property damage, injury or death. Read the installation, operating and maintenance instructions thoroughly before installing or servicing this equipment.

NOTICE

During the warranty period, ALL parts replacement and servicing should be performed by your Middleby Marshall Authorized Service Agent. Service that is performed by parties other than your Middleby Marshall Authorized Service Agent may void your warranty.

NOTICE

Using any parts other than genuine Middleby Marshall factory manufactured parts relieves the manufacturer of all warranty and liability.

NOTICE

Middleby Marshall reserves the right to change specifications at any time.

CFESA

Commercial Food Equipment Service Association

Middleby is proud to support the Commercial Food Equipment Service Association (CFESA). We recognize and applaud CFESA's ongoing efforts to improve the quality of technical service in the industry.

Middleby Cooking Systems Group • 1400 Toastmaster Drive • Elgin, IL 60120 • USA • (847)741-3300 • FAX (847)741-4406

www.middleby.com

