

PS636 Series Gas Ovens

Model:

- PS636G Gas

Combinations:

- Single Oven
- Double Oven (Two-Stack)
- Triple Oven (Three-Stack)

OWNER'S OPERATING AND INSTALLATION MANUAL

for domestic and standard export ovens

©2014 Middleby Marshall Inc.



is a registered trademark of Middleby Marshall, Inc. All rights reserved.
Middleby Cooking Systems Group • 1400 Toastmaster Drive • Elgin, IL 60120 • (847)741-3300 • FAX (847)741-4406



NOTICE:

This Owner's Operating and Installation Manual should be given to the user. The operator of the oven should be familiar with the functions and operation of the oven.

This manual must be kept in a prominent, easily reachable location near the oven.

Ovens are shipped from the factory configured for use with natural gas. If permitted by local, national and international codes, at the time of installation the oven may be converted to propane gas operation. This conversion requires the use of a Gas Conversion Kit that is supplied with the oven. For CE-approved ovens, the conversion is described in the *Installation* section of this Manual. For domestic and standard export ovens, instructions are included in the Gas Conversion Kit.

It is suggested to obtain a service contract with a Middleby Marshall Authorized Service Agent.

WARNING

POST, IN A PROMINENT LOCATION, THE EMERGENCY TELEPHONE NUMBER OF YOUR LOCAL GAS SUPPLIER AND INSTRUCTIONS TO BE FOLLOWED IN THE EVENT YOU SMELL GAS.

Instructions to be followed in the event the user smells gas shall be obtained by consulting the local gas supplier. If the smell of gas is detected, immediately call the emergency phone number of your local Gas Company. They will have personnel and provisions available to correct the problem.

WARNING

FOR YOUR SAFETY, DO NOT STORE OR USE GASOLINE OR OTHER FLAMMABLE VAPORS AND LIQUIDS IN THE VICINITY OF THIS OR ANY OTHER APPLIANCE.

WARNING

Improper installation, adjustment, alteration, service, or maintenance can cause property damage, injury, or death. Read the installation, operation, and maintenance instructions thoroughly before installing or servicing this equipment.

WARNING

DO NOT SPRAY AEROSOLS IN THE VICINITY OF THIS APPLIANCE WHILE IT IS IN OPERATION.

IMPORTANT

An electrical wiring diagram for the oven is located inside the machinery compartment.

IMPORTANT

It is the customer's responsibility to report any concealed or non-concealed damage to the freight company. Retain all shipping materials until it is certain that the equipment has not suffered concealed shipping damage.

NOTICE

CONTACT YOUR MIDDLEBY MARSHALL AUTHORIZED SERVICE AGENT TO INSTALL AND PERFORM MAINTENANCE AND REPAIRS AND IF NECESSARY TO CONVERT EQUIPMENT FOR USE WITH OTHER GASES. AN AUTHORIZED SERVICE AGENCY DIRECTORY IS SUPPLIED WITH YOUR OVEN.

NOTICE

Using any parts other than genuine Middleby Marshall factory manufactured parts relieves the manufacturer of all warranty and liability.

NOTICE

Middleby Marshall (Manufacturer) reserves the right to change specifications at any time.

NOTICE

The equipment warranty is not valid unless the oven is installed, started and demonstrated under the supervision of a factory certified installer.

NOTICE

THIS EQUIPMENT IS ONLY FOR PROFESSIONAL USE AND SHALL BE USED BY QUALIFIED PERSONNEL.

RETAIN THIS MANUAL FOR FUTURE REFERENCE.

Model No. _____
Modèle No. _____

Serial No. _____
Série No. _____

Installation Date _____
Date d'installation _____

**MIDDLEBY MARSHALL
NO QUIBBLE LIMITED WARRANTY
(U.S.A. ONLY)**

MIDDLEBY MARSHALL, HEREINAFTER REFERRED TO AS "THE SELLER", WARRANTS EQUIPMENT MANUFACTURED BY IT TO BE FREE FROM DEFECTS IN MATERIAL AND WORKMANSHIP FOR WHICH IT IS RESPONSIBLE. THE SELLER'S OBLIGATION UNDER THIS WARRANTY SHALL BE LIMITED TO REPLACING OR REPAIRING, AT SELLER'S OPTION, WITHOUT CHARGE, ANY PART FOUND TO BE DEFECTIVE AND ANY LABOR AND MATERIAL EXPENSE INCURRED BY SELLER IN REPAIRING OR REPLACING SUCH PART. SUCH WARRANTY SHALL BE LIMITED TO THE ORIGINAL PURCHASER ONLY AND SHALL BE EFFECTIVE FOR A PERIOD OF ONE YEAR FROM DATE OF ORIGINAL INSTALLATION, OR 18 MONTHS FROM DATE OF PURCHASE, WHICHEVER IS EARLIER, PROVIDED THAT TERMS OF PAYMENT HAVE BEEN FULLY MET.

This warranty is valid only if the equipment is installed, started, and demonstrated under the supervision of a factory-authorized installer.

Normal maintenance functions, including lubrication, cleaning, or customer abuse, are not covered by this **no quibble warranty**.

Seller shall be responsible only for repairs or replacements of defective parts performed by Seller's authorized service personnel. Authorized service agencies are located in principal cities throughout the contiguous United States, Alaska, and Hawaii. This warranty is valid in the 50 United States and is void elsewhere unless the product is purchased through Middleby International with warranty included.

The foregoing warranty is exclusive and in lieu of all other warranties, expressed or implied. There are no implied warranties of merchantability or of fitness for a particular purpose.

The foregoing shall be Seller's sole and exclusive obligation and Buyer's sole and exclusive remedy for any action, including breach of contract or negligence. In no event shall Seller be liable for a sum in excess of the purchase price of the item. Seller shall not be liable for any prospective or lost profits of Buyer.

This warranty is effective on Middleby Marshall equipment sold on, or after, February 15, 1995.

**MIDDLEBY MARSHALL INC.
OVEN LIMITED WARRANTY
(Non U.S.A.)**

The Seller warrants equipment manufactured by it to be free from defects in material and workmanship for which it is responsible. The Seller's obligation under this warranty shall be limited to replacing or repairing, at Seller's option, without charge, F.O.B. Seller's factory, any part found to be defective and any labor and material expense incurred by Seller in repairing or replacing such part. Such warranty is limited to a period of one year from date of original installation or 15 months from date of shipment from Seller's factory, whichever is earlier, provided that terms of payment have been fully met. All labor shall be performed during regular working hours. Overtime premium will be charged to the Buyer.

This warranty is not valid unless equipment is installed, started, and demonstrated under the supervision of a factory-authorized installer.

Normal maintenance functions, including lubrication, adjustment of airflow, thermostats, door mechanisms, microswitches, burners and pilot burners, and replacement of light bulbs, fuses and indicating lights, are not covered by warranty.

Any repairs or replacements of defective parts shall be performed by Seller's authorized service personnel. Seller shall not be responsible for any costs incurred if the work is performed by other than Seller's authorized service personnel.

When returning any part under warranty, the part must be intact and complete, without evidence of misuse or abuse, freight prepaid.

Seller shall not be liable for consequential damages of any kind which occur during the course of installation of equipment, or which result from the use or misuse by Buyer, its employees or others of the equipment supplied hereunder, and Buyer's sole and exclusive remedy against Seller for any breach of the foregoing warranty or otherwise shall be for the repair or replacement of the equipment or parts thereof affected by such breach.

The foregoing warranty shall be valid and binding upon Seller if and only if Buyer loads, operates and maintains the equipment supplied hereunder in accordance with the instruction manual provided to Buyer. Seller does not guarantee the process of manufacture by Buyer or the quality of product to be produced by the equipment supplied hereunder and Seller shall not be liable for any prospective or lost profits of Buyer.

THE FOREGOING WARRANTY IS EXCLUSIVE AND IN LIEU OF ALL OTHER EXPRESS AND IMPLIED WARRANTIES WHATSOEVER. SPECIFICALLY THERE ARE NO IMPLIED WARRANTIES OF MERCHANTABILITY OR OF FITNESS FOR A PARTICULAR PURPOSE.

The foregoing shall be Seller's sole and exclusive obligation and Buyer's sole and exclusive remedy for any action, whether in breach of contract or negligence. In no event shall seller be liable for a sum in excess of the purchase price of the item.

TABLE OF CONTENTS

	Page		Page
SECTION 1 – DESCRIPTION	1	SECTION 3 – FEATURES & OPERATION	13
I. OVEN USES	1	I. PS636 CONTROL KEYS.....	13
II. OVEN COMPONENTS	1	II. DISPLAY FEATURES	14
A. Conveyor Motor Drive	1	III. CONTROL FEATURES	15
B. Crumb Pans	1	IV. OPERATION	15
C. Conveyor	1	A. STARTING THE OVEN.....	15
D. End Plugs	1	B. ADJUSTING THE TEMPERATURE	15
E. Eyebrows	1	C. ADJUSTING THE BELT TIME	15
F. Window	1	D. TURNING OFF THE OVEN	15
G. Machinery Compartment Access Panel	1	E. ENERGY MANAGEMENT	16
H. Serial Plate	1	V. TROUBLESHOOTING GUIDE	17
I. Control Panel	1	 	
J. Photo Cell	1	SECTION 4 - MAINTENANCE	
K. Gas Burner	1	I. MAINTENANCE - DAILY	18
L. Blowers	1	II. MAINTENANCE - MONTHLY	19
M. Air Fingers	1	III. MAINTENANCE - EVERY THREE MONTHS	20
III. OVEN SPECIFICATIONS	2	IV. MAINTENANCE - EVERY SIX MONTHS	21
A. Dimensions	2	V. KEY SPARE PARTS KIT	22
B. General Specifications	2		
C. Electrical Specifications for PS636 Gas Ovens	2	SECTION 5 - ELECTRICAL WIRING DIAGRAMS	
D. Gas Orifice and Pressure Specifications for PS636 Gas Ovens	2	208-240 V, 50/60Hz, 1 Phase.....	23
SECTION 2 – INSTALLATION	3		
I. INSTALLATION KIT	4		
II. VENTILATION SYSTEM	5		
A. Requirements	5		
B. Recommendations	5		
C. Other Ventilation Concerns	5		
III. ASSEMBLY	6		
A. Base Pad, Legs, Casters	6		
B. Stacking	7		
C. Restraint Cable Installation	7		
D. Conveyor Installation	8		
IV. FINAL ASSEMBLY	8		
V. ELECTRICAL SUPPLY	9		
Connection	10		
VI. GAS SUPPLY	10		
A. Gas Utility Rough-In Recommendations	10		
B. Connection	11		
C. Gas Conversion	11		
D. Propane Conversion	11		
E. Adjusting the Maximum Pressure Setting	11		
F. Adjusting the Minimum Pressure Setting	12		
G. Checkout	12		
H. Maintenance	12		

NOTE

Wiring Diagrams are in Section 5 of this Manual.
The diagram for each oven is also on the lower
inner surface of its Control Console.

SECTION 1 – DESCRIPTION

I. OVEN USES

PS636 Series Ovens can be used to bake and/or cook a wide variety of food products, such as pizza, pizza –type products, cookies, sandwiches and others.

II. OVEN COMPONENTS – see Figure 1-1.

- A. **Conveyor Drive Motor:** Moves the conveyor.
- B. **Crumb Pans:** Catch crumbs and other materials that drop through the conveyor belt. One crumb pan is located at each end of the conveyor.
- C. **Conveyor:** Moves the food product through the oven.
- D. **End Plugs:** Allow access to the oven's interior.
- E. **Eyebrows:** Can be adjusted to various heights to prevent heat loss into the environment.
- F. **Window:** Allows the user to access food products inside the baking chamber.
- G. **Machinery Compartment Access Panel:** Allows access to the oven's interior and control components. No user serviceable parts are located in the machinery compartment.
- H. **Serial Plate:** Provides specifications for the oven that affect installation and operation. Refer to Section 2, [Installation](#) for details.
- I. **Control Panel:** Location of the operating controls for the oven. Refer to Section 3, [Operation](#), for details.
- J. **Photo Cell:** Turns oven On when beam is interrupted.

Not Shown:

- K. **Gas Burner (gas ovens):** Heat air, which is then projected to the air fingers by the blowers.
- L. **Blowers:** Project hot air from the burner or heating element to the air fingers.
- M. **Air Fingers:** Project streams of hot air onto the food product.

Figure 1-1. Oven Components

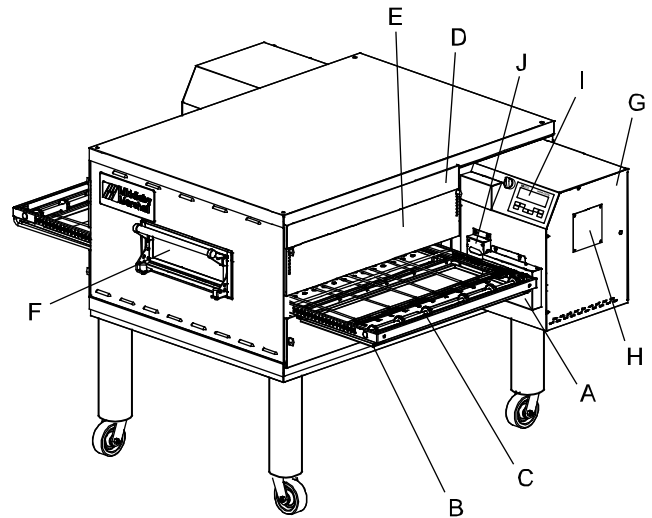

I. OVEN SPECIFICATIONS

Table 1-1 Dimensions	Single Oven	Double Oven	Triple Oven
Overall Height	44" (1118mm)	62-3/8" (1635mm)	69-3/4" (1171mm)
Overall Depth	44-1/2" (1130mm)	44-1/2" (1130mm)	44-1/2" (1130mm)
Overall Length (w/o exit trays)	65-3/4" (1670mm)	65-3/4" (1670mm)	65-3/4" (1670mm)
Conveyor Width – belt width is 24"	25-1/2" (648mm) or 2 x 11" (279mm)	25-1/2" (648mm) or 2 x 11" (279mm)	25-1/2" (648mm) or 2 x 11" (279mm)

Recommended Minimum Clearances			
Rear of Oven to Wall	0" (0mm)	0" (0mm)	0" (0mm)
Control end of conveyor to Wall	2" (50.8mm)	2" (50.8mm)	2" (50.8mm)
Non-control end of conveyor to Wall	2" (50.8mm)	2" (50.8mm)	2" (50.8mm)

Table 1-2: General Specifications PS636 GAS	24" Belt
Weight	734 lbs. (333kg)
Rated Heat Input	75,000 BTU (18,892kcal, 22 kW/hr)
Maximum Operation Temperature	600°F / 315°C
Air Blowers	Four Blowers at 3400 RPM (max)
Warmup Time	15 min.

Table 1-3: Electrical specifications for PS363G gas ovens						
Main Blower Voltage	Control Circuit Voltage	Phase	Freq	Current Draw	Poles	Wires
208-240VAC	208-240VAC	1Ph	50/60Hz	4-3 Amp	2 Pole	3 Wire (2 hot, 1 gd)

Table 1-4: Gas orifice and pressure specifications for PS636G gas ovens				
Gas Type	Main Orifice I.D. PS745G	Supply (Inlet) Pressure	Orifice (Manifold) Pressure	Bypass Pressure
Natural	0.094 (2.375120mm)	8-12" W.C. (19.9 - 29.9mbar)	3.5" W.C. (8.7mbar)	0.3-0.35" W.C. (0.8-0.9 mbar)
Propane	0.057" (1.45mm)	11-14" W.C. (27.4 - 34.9mbar)	10.0" W.C. (24.9mbar)	0.9-1.0" W.C. (2.2-2.5 mbar)

IMPORTANT – Additional electrical information is provided on the oven’s serial plate, and on the wiring diagram inside the machinery compartment.

GAS ORIFICE AND PRESSURE SPECIFICATIONS (PER OVEN CAVITY) - CE OVENS

Gas Type	Main Orifice dia.	AT,BG,CR CZ,DK,EE FI,GR,HR HU,IS,IE IT,LV,LT NO,PT,RO SK,SI,ES SE,CH,TR				DE LU PL FR			BE FR SK		FI,CR,GR IE,HR,LU NL,PL,SK SI,ES,CH TR,GB,CY CZ,DE,MT		CY,CZ DE,MT SK		SW,CH AT,DK NO,FI NI,CR		BG,CY,CR CZ,DK,EE FI,GR,HR LV,LT,LU MT,NL,NO		BE,CY,CZ EE,FR GR,IE,IT LT,LU,LV PT,RO,SK		Orifice (Manifold) Pressure	Rated Heat Input
		GB I _{2H}	NL I _{2L}	PL I _{2E}	FR I _{2E+}	SK I _{3P}	SK I _{3P}	FR I _{3B/P}	FR I _{3B/P}	TR I _{3B/P}	CH I _{3B/P}	ES,CH I ₃₊	ES,CH I ₃₊									
G20 Natural	.0935" (2.375 mm)	20 mbar	-- mbar	20 mbar	20 mbar	-- mbar	-- mbar	-- mbar	-- mbar	-- mbar	-- mbar	-- mbar	-- mbar	-- mbar	-- mbar	-- mbar	-- mbar	-- mbar	3.5" w.c. 8.7mbar	22kW		
G25 Natural	.0935" (2.375 mm)	-- mbar	25 mbar	-- mbar	-- mbar	-- mbar	-- mbar	-- mbar	-- mbar	-- mbar	-- mbar	-- mbar	-- mbar	-- mbar	-- mbar	-- mbar	-- mbar	-- mbar	3.5" w.c. 8.7mbar	22kW		
G30 Butane	.057" (1.45 mm)	-- mbar	-- mbar	-- mbar	-- mbar	-- mbar	-- mbar	-- mbar	28-30/50 mbar	30 mbar	37/50 mbar	28-30 mbar	10.0" w.c. 24.9mbar	24.6kW								
G31 Propane	.057" (1.45 mm)	-- mbar	-- mbar	-- mbar	-- mbar	37 mbar	50 mbar	-- mbar	30 mbar	37/50 mbar	37 mbar	10.0" w.c. 24.9mbar	22kW									

NOTE
Wiring Diagrams are contained in Section 5 of this Manual and are also located inside the oven at the bottom of the Control Panel.
Additional electrical information is provided on the oven's serial plate.

This Manual Must Be Kept For Future Reference

SECTION 2 – INSTALLATION

WARNING – After any conversions, readjustments, or service work on the oven:

- Perform a gas leak test.
- Test for proper combustion and gas supply.
- Test for correct air supply, particularly to the burner blower.
- Check that the ventilation system is in operation.

WARNING - Keep the appliance area free and clear of combustibles.

WARNING – The oven must be installed on an even (level) non-flammable flooring and any adjacent walls must be non-flammable. Recommended minimum clearances are specified in the Description section of this manual.

WARNING – Do not obstruct the flow of combustion and ventilation air to and from your oven. There must be no obstructions around or underneath the oven. Constructional changes to the area where the oven is installed shall not affect the air supply to the oven.

CAUTION: To reduce the risk of fire, the appliance is to be mounted on floors of noncombustible construction with noncombustible flooring and surface finish and with no combustible material against the underside thereof, or on noncombustible slabs or arches having no combustible material against the underside thereof, such construction shall in all cases extend not less than 12 inches (304mm) beyond the equipment on all sides.

CAUTION: For additional installation information, contact your local Authorized Service Agent.

NOTE – There must be adequate clearance between the oven and combustible construction. Clearance must also be provided for servicing and for proper operation.

NOTE – An electrical wiring diagram for the oven is located inside the machinery compartment.

NOTE: All aspects of the oven installation, including placement, utility connections, and ventilation requirements, must conform with any applicable local, national, or international codes. These codes supersede the requirements and guidelines provided in this manual.

NOTE: In the USA, the oven installation must conform to local codes. In the absence of local codes, gas oven installations must conform with the National Fuel Gas Code, ANSI Z223.1. Gas and electric ovens, when installed, must be electrically grounded in accordance with local codes, or in the absence of local codes, with the National Electrical Code (NEC), or ANSI/NFPA70.

NOTE: In Canada, the oven installation must conform with local codes. In the absence of local codes, gas oven installations must conform with the Natural Gas Installation Code, CAN/CGA-B149.1, or the Propane Gas Installation Code, CAN/CGA-B149.2, as applicable. Gas and electric ovens, when installed, must be electrically grounded in accordance with local codes, or in the absence of local codes, with the Canadian Electrical Code
CSA C22.2.

NOTE: In Australia, the oven installation must conform with local codes. In the absence of local codes, gas oven installations must conform with the requirements of AS5601/AG601, Gas, Electricity, and any other relevant statutory regulations.

PS636 24" OVEN INSTALLATION REQUIRED KITS AND EQUIPMENT

Type Of Installation	PS636 Gas Oven Installation Kit	PS636 Single Oven Option Base w/ 15" Legs, Casters & Top Kit P/N 66129	PS636 Double Oven Option Base w/ 15" Legs, Casters & Top Kit P/N 66027	PS636 Triple Oven Option Base w/ 15" Legs, Casters & Top Kit P/N 6xxxx
PS636 Single Gas Oven	66331	1		
PS636 Double Gas Oven	66332		1	
PS636 Triple Gas Oven	66333			1

PARTS LIST FOR SERIES PS636 GAS OVEN INSTALLATION KIT

ITEM NO.	66331 QTY	66332 QTY	66333 QTY	PART NO.	DESCRIPTION
1	1	1	1	22450-0228	RESTRAINT CABLE
2	1	2	3	50546	TAP AND ADAPTER
3	1	2	3	62307	GAS BALL VALVE
4	1	2	3	22361-0001	FLEXIBLE GAS HOSE
5	1	2	3	66241	LH CONTROL BOX GUARD
6	1	2	3	66244	RH CONTROL BOX GUARD

Figure 2-1A. PS636-Series Gas Oven Installation Parts

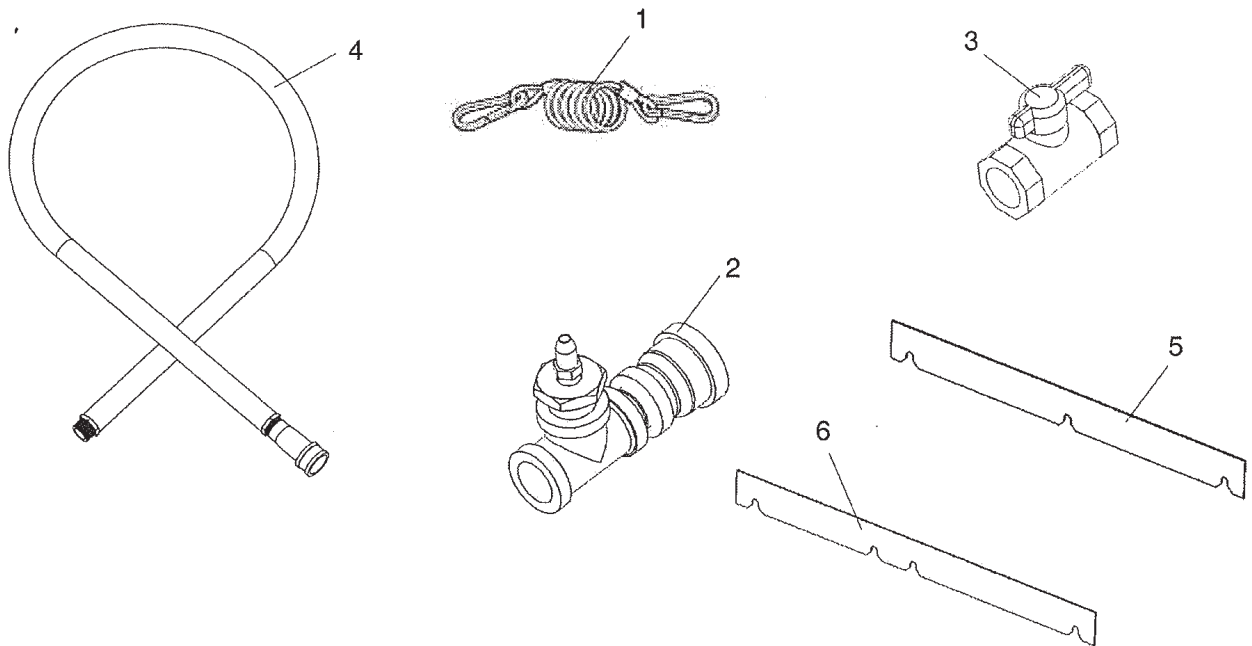

III. VENTILATION SYSTEM

IMPORTANT

Where national or local codes require the installation of fire suppression equipment or other supplementary equipment, **DO NOT** mount the equipment directly to the oven.

MOUNTING SUCH EQUIPMENT ON THE OVEN MAY:

- **VOID AGENCY CERTIFICATIONS**
- **RESTRICT SERVICE ACCESS**
- **LEAD TO INCREASED SERVICE EXPENSES FOR THE OWNER**

A. Requirements

CAUTION: Gas oven installations **REQUIRE** a mechanically driven ventilation system with electrical exhaust air sensing control.



A mechanically driven ventilation system is **STRONGLY RECOMMENDED** for electric oven installations.

PROPER VENTILATION OF THE OVEN IS THE RESPONSIBILITY OF THE OWNER.

B. Recommendations

NOTE THAT THE HOOD DIMENSIONS SHOWN IN FIGURE 2-5 ARE **RECOMMENDATIONS ONLY**. LOCAL, NATIONAL AND INTERNATIONAL CODES MUST BE FOLLOWED WHEN INSTALLING THE VENTILATION SYSTEM. ANY APPLICABLE CODES SUPERSEDE THE RECOMMENDATIONS SHOWN IN THIS MANUAL. IN AUSTRALIA COMPLIANCE TO REGULATIONS AS5601/AG601 IS MANDATORY.

The rate of air flow exhausted through the ventilation system may vary depending on the oven configuration and hood design. Consult the hood manufacturer or ventilation engineer for these specifications.

To avoid a negative pressure condition in the kitchen area, return air must be brought back to replenish the air that was exhausted. A negative pressure in the kitchen can cause heat-related problems to the oven components as if there were no ventilation at all. The best method of supplying return air is through the heating, ventilation and air conditioning (HVAC) system. Through the HVAC system, the air can be temperature-controlled for summer and winter. Return air can also be brought in directly from outside the building, but detrimental effects can result from extreme seasonal hot and cold temperatures from the outdoors.

NOTE: Return air from the mechanically driven system **must not** blow at the opening of the baking chamber. Poor oven baking performance will result.

C. Other ventilation concerns

- Special locations, conditions, or problems may require the services of a ventilation engineer or specialist.
- Inadequate ventilation can inhibit oven performance.
- It is recommended that the ventilation system and duct work be checked at prevailing intervals as specified by the hood manufacturer and/or HVAC engineer or specialist.

Figure 2-5. Ventilation System

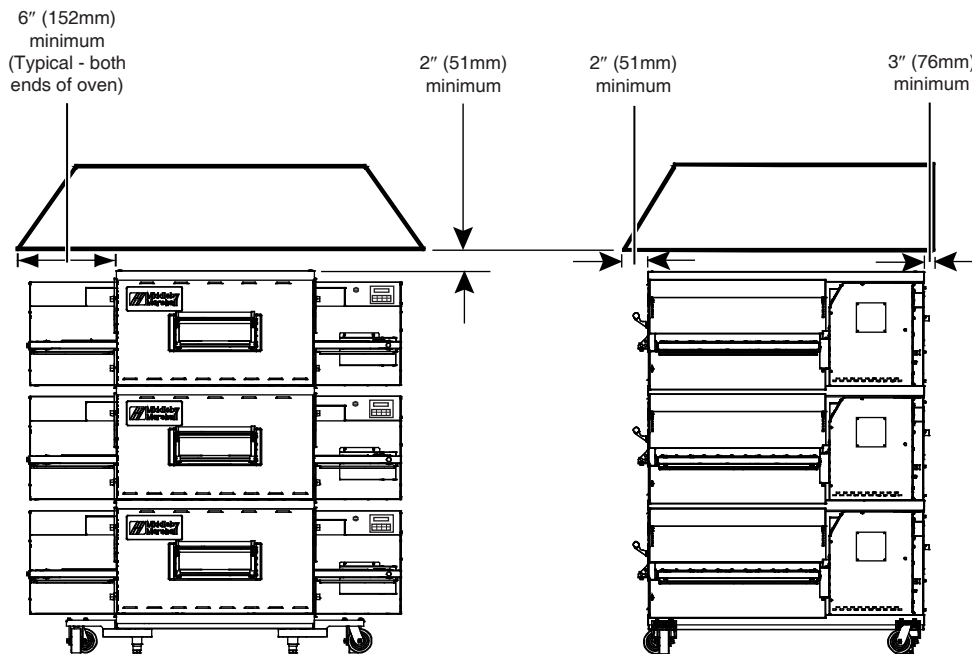

IV. ASSEMBLY

A. Top Panel and Base Pad Assembly

1. Install the four leg extensions onto the base pad using the 3/8"-16 x 1" screws, 3/8" flat washers, and 3/8" lockwashers supplied in the Base Pad Kit. See Figure 2-6. Check that the finished sides of each leg extension face OUTWARDS. One rear leg should be attached using three 3/8"-16 x 1" screws and the 3/4" eyebolt, as shown in Figure 2-6. This eyebolt acts as the anchor point for the restraint cable assembly (see Part C, Restraint Cable Installation).
2. If your oven is equipped with the lower shelf, position it in place as shown in Figure 2-6. Check that the lip on the shelf faces DOWN. Seal joint between leg and shelf with NSF listed silicone.
3. Install one caster onto each leg extension, as shown in Figure 2-7. Use the 3/8"-16 x 1" screws, 3/8" flat washers, and 3/8" lockwashers supplied in the Installation Kit. The locking casters should be installed at the FRONT of the oven. The non-locking casters should be installed at the REAR of the oven.
4. Install the lower oven cavity onto the base pad. See Fig 2-7.
5. For single ovens ONLY:

Install the top panel using the screws included in the base pad kit, as shown in Figure 2-8. Then, skip ahead to Part C, Restraint Cable Installation.

For double or triple ovens:

Continue on to Part B, Stacking. Note that the top panel should NOT be installed for double and triple ovens until after stacking the oven cavities.

Figure 2-6. Leg extension and casters installation

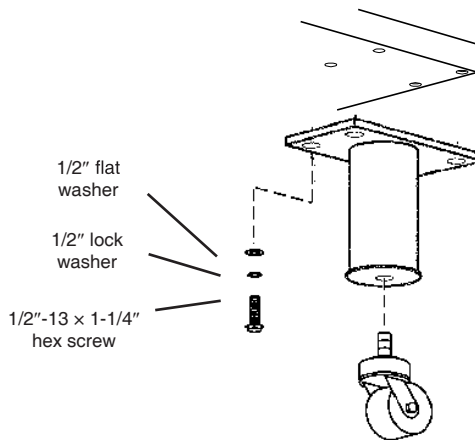

Figure 2-7. Base pad Installation

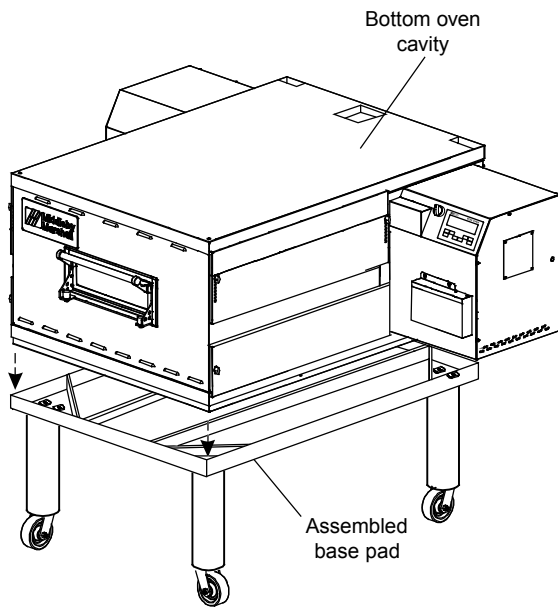
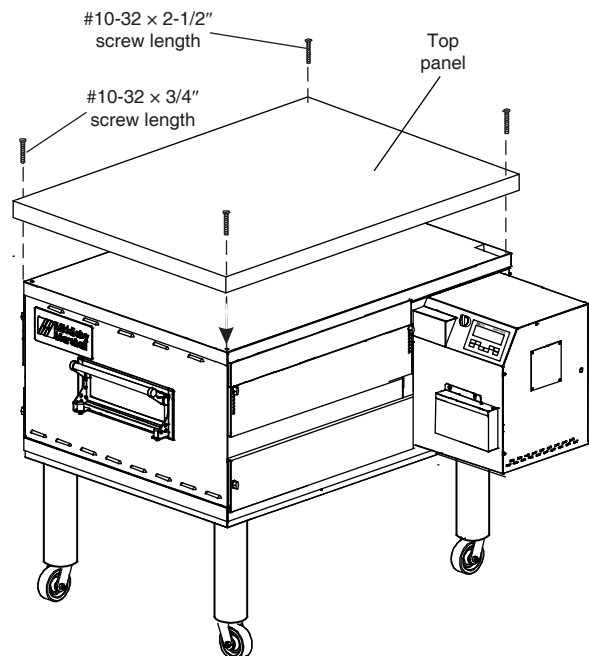

Figure 2-8. Top panel installation



NOTE: DO NOT install top panel onto double or triple ovens until AFTER stacking the oven cavities. See Part B, Stacking.

B. Stacking

For single ovens, skip ahead to Part C, Restraint Cable Installation.

IMPORTANT

Middleby Marshall **STRONGLY RECOMMENDS** that PS745 Gas oven cavities be stacked **BY AUTHORIZED PERSONNEL**.

Contact your Middleby Marshall Authorized Service Agent for complete stacking instructions.

1. Stack an oven cavity on top of the lower oven. Check the following:

- All four sides of the lower lip (on the bottom edge of the oven cavity) overlap the top of the lower oven
- The oven is level
- The oven is firmly seated

See Figure 2-9.

2. For triple ovens, repeat Step 1 to install the top oven cavity.

3. Install the top panel using the screws included in the base pad kit, as shown in Figure 2-10.

Figure 2-9. Stacking

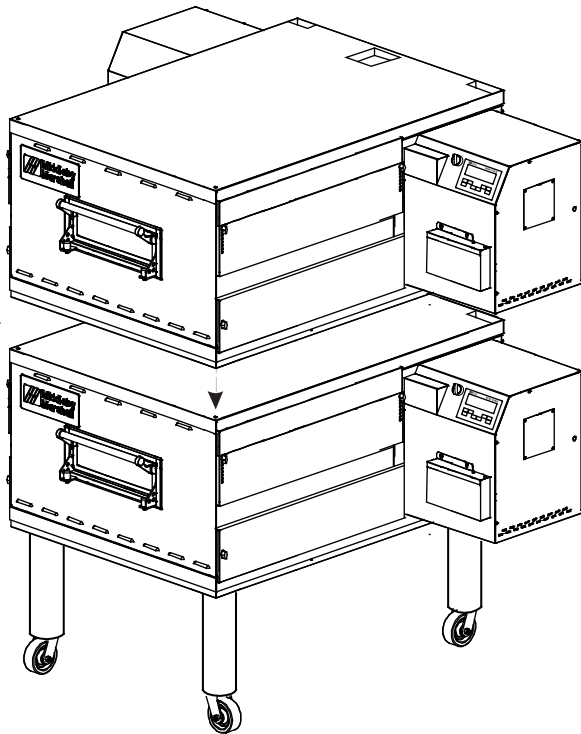

C. Restraint Cable Installation

Because the oven is equipped with casters, a restraint cable assembly must be installed to limit the movement of the appliance without depending on the connector and the quick disconnect device or its associated piping. One end of the cable is anchored to the eyebolt on the rear surface of the oven's base pad, while the other is anchored to the wall. See Figure 2-11.

After connecting the restraint cable, move the oven to its final location. Adjust the bottom (hex) sections of the feet so that the casters are off the floor. For quad ovens, lock the two front casters.

Figure 2-10. Top panel installation

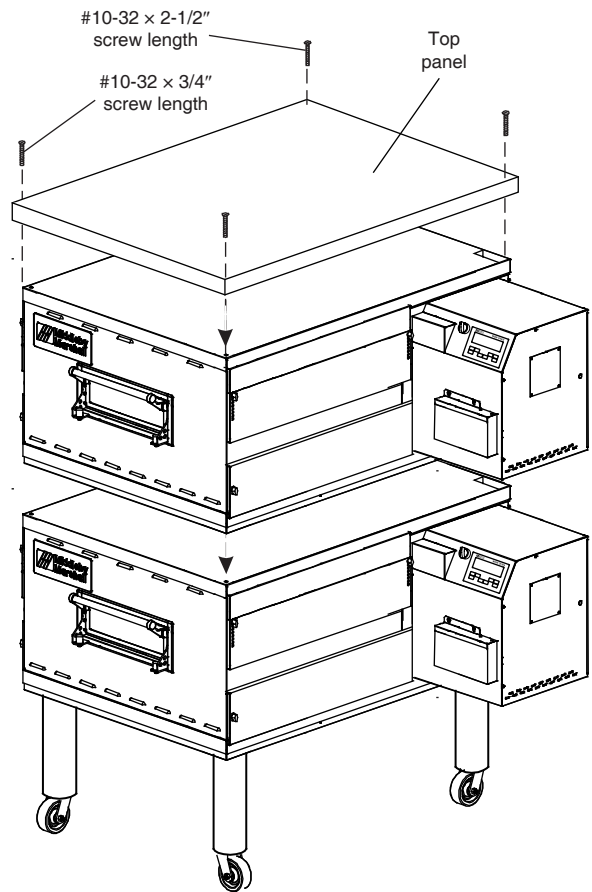
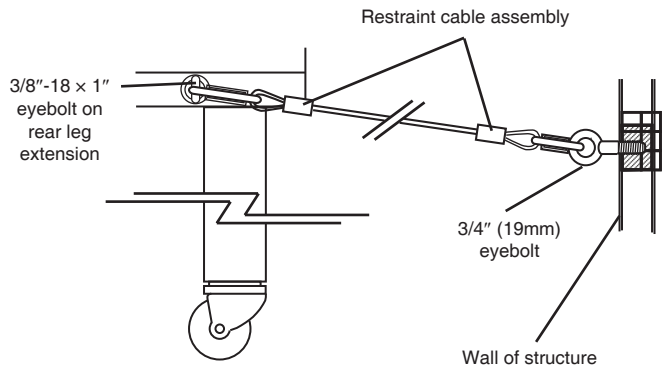

Figure 2-11. Installing the Restraint Cable



D. Conveyor Installation

1. Unfold the conveyor as shown in Figure 2-12. Then, begin to slide the conveyor into the end of the oven. The conveyor can only be installed from the end of the oven with the drive motor.
2. Continue moving the conveyor into the oven until the frame protrudes equally from each end of the oven. Check that the crumb tray supports located on the underside of the conveyor frame rest firmly against the lower end plugs, as shown in Figure 2-13.
3. When the conveyor is positioned properly, check for freedom of movement of the conveyor belt by pulling it for about 2-3 feet (0.6-1.0m) with your fingers. The drive and idler shafts must rotate smoothly, and the belt must move freely without rubbing on the inside of the oven.
4. Check the tension of the conveyor belt as shown in Figure 2-14. The belt should lift about 1" (25mm). **DO NOT OVERTIGHTEN THE CONVEYOR BELT.**

NOTE: If necessary, the belt tension can be adjusted by turning the conveyor adjustment screws, located at the idler (non-control) end of the conveyor. See Figure 2-14.

Figure 2-12. Conveyor installation

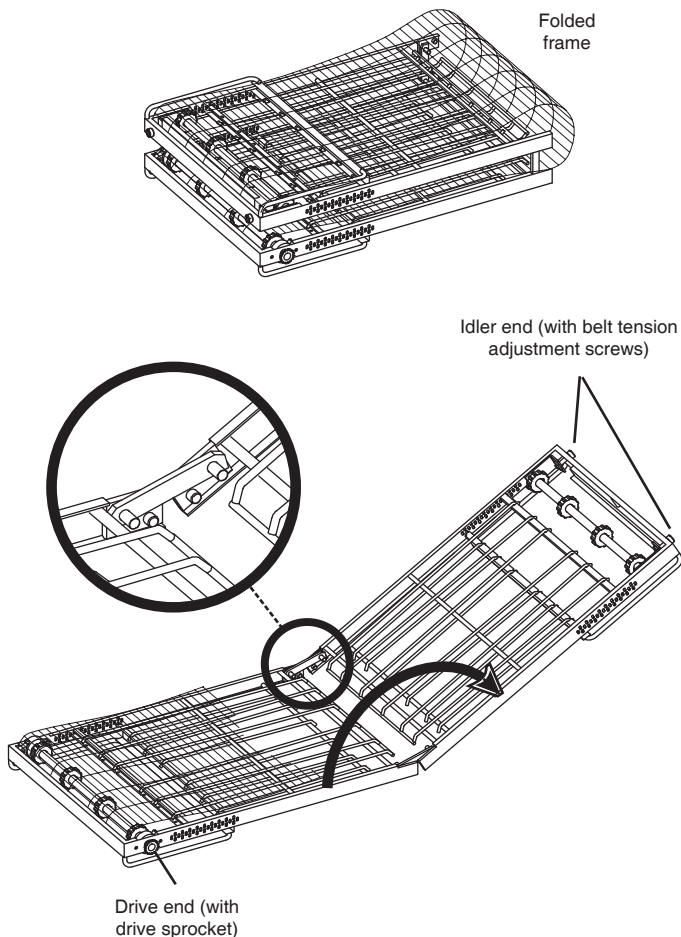

Figure 2-13. Conveyor placement

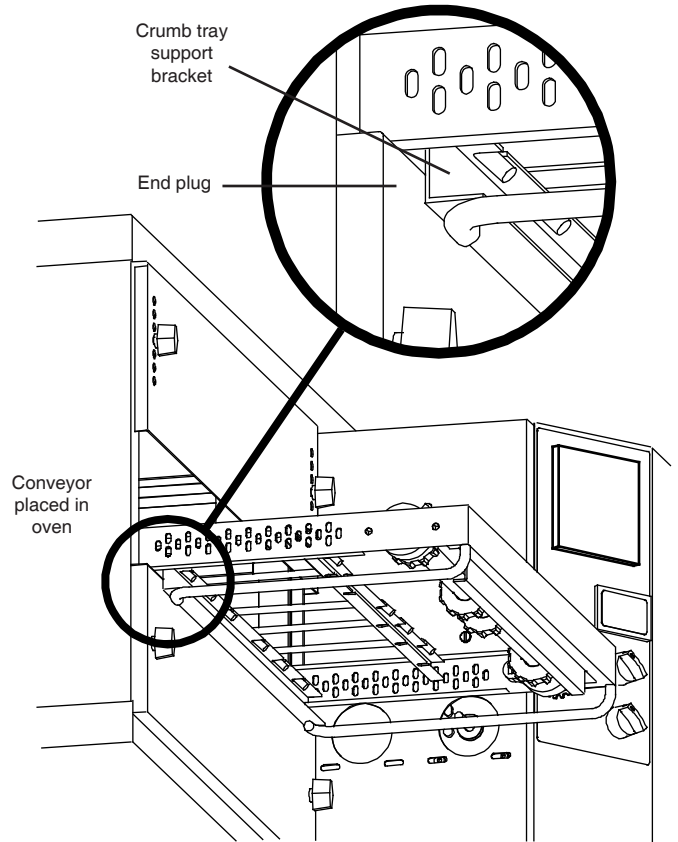
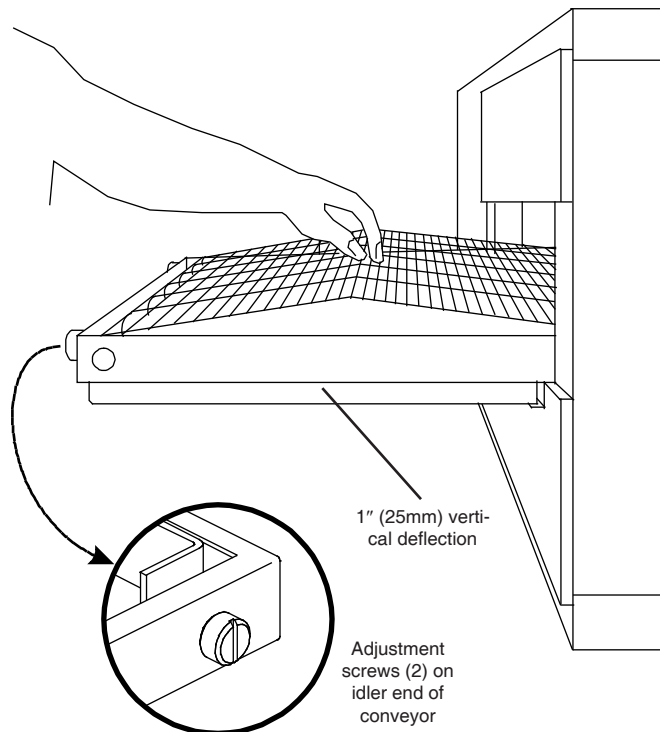
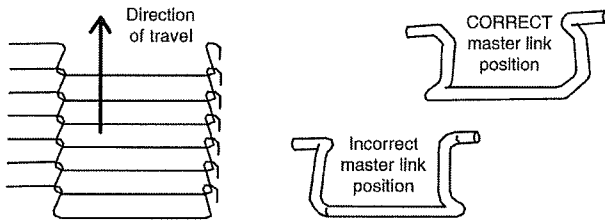

Figure 2-14. Conveyor Belt tension



5. If it is necessary to add or remove conveyor links to achieve the correct tension, OR if it is necessary to reverse the conveyor belt for correct orientation, the belt will need to be removed from the conveyor frame. If this is necessary, perform the following procedure:
 - Remove the conveyor assembly from the oven and place it flat on the floor.
 - Remove the master links using long-nose pliers. Then, roll up the belt along the length of the conveyor frame.
 - Add or remove belt links as necessary to achieve the correct belt tension.
 - Replace the belt on the conveyor frame. Check that the conveyor belt links are oriented as shown in Figure 2-15, and that the smooth side of the conveyor belt faces UP.
 - Connect the inside master links. Check that the links are oriented as shown in Figure 2-15.
 - Connect the outside master links. Note that the outside master links each have an open hook on one side. This hook aligns with the hooks along the sides of the other conveyor links. See Figure 2-15.
 - Replace the conveyor into the oven.

Figure 2-15. Conveyor and Master Link orientation



E. Final Assembly

1. Install the crumb trays underneath the conveyor as shown in Figure 2-16.

Figure 2-16. Crumb Trays

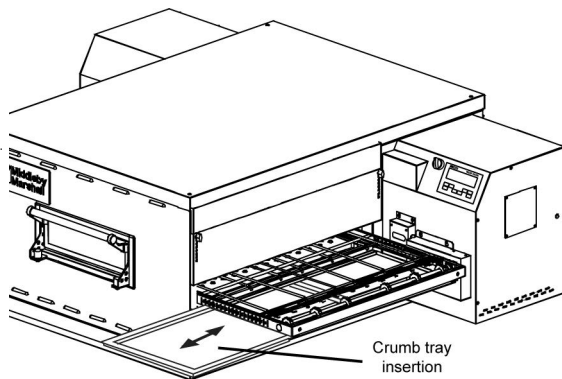

CONVEYOR BELT REVERSAL

Conveyor belt reversal consists of three steps:

1. Physically reversing the conveyor belt.
2. Resetting direction through the user interface.
3. Switching the photo detector.

REVERSING THE CONVEYOR BELT

Remove the conveyor from the oven and find the master link location. Remove master links and remove the belt from the conveyor frame. Reassemble the belt back onto the frame (in the reverse direction) and reinstall the master links. Replace the conveyor assembly in the oven.

RESETTING DIRECTION

See OVEN CONFIGURATION MENU in PS636G TECH SERVICE GUIDE. Direction is changed through the user interface with no wiring changes necessary.

CAUTION: Shock hazard in compartments electrical filters are electrically alive.



SWITCHING PHOTO DETECTOR

CAUTION: Disconnect Power Before Switching Photo eye.



Remove the three screws securing the access door to the unit. Open the access door and disconnect the connector fitting to the photo eye assembly. Remove the two screws securing the photo eye assembly to the control box. Remove the four nuts securing the photo eye to the housing. Rotate the photo eye 180 degrees and resecure the photo eye with the four nuts.

On the opposite control box, remove the two screws holding the cover where the photo eye assembly will be positioned. Secure the photo eye assembly in position with the two screws. Place the photo eye cover on the opposite control box, where the photo eye assembly was removed, and secure the two screws. Secure the access door with the three screws.

Remove the three screws securing the access door on the opposite side. Open the access door, where the photo eye is now positioned, and connect the photo eye connector fitting. Secure the access door with the three screws.

Apply power to the unit. Adjust the photo eye height by loosening the two screws securing the photo eye assembly and sliding the photo eye assembly either up or down, such that the beam is approximately 1/4 inch above the belt.

Note: This is MUCH easier in reduced light.

Replace all covers.

VI. ELECTRICAL SUPPLY

WARNING: Authorized installation personnel normally accomplish the connections for the ventilation system, electric supply, and gas supply, as arranged by the customer. Following these connections, the factory-authorized installer can perform the initial startup of the oven.



NOTE: The electric supply installation must satisfy the requirements of the appropriate statutory authority such as the National Electrical Code, CSA C22.2; the Australian Code AG601; or other applicable regulations.

NOTE: The electric supply connection must meet all national and local electrical code requirements.

Check the oven serial plate before making any electric supply connections. Electric supply connections must agree with data

Figure 2-17. Utility Connection Locations for Gas Ovens

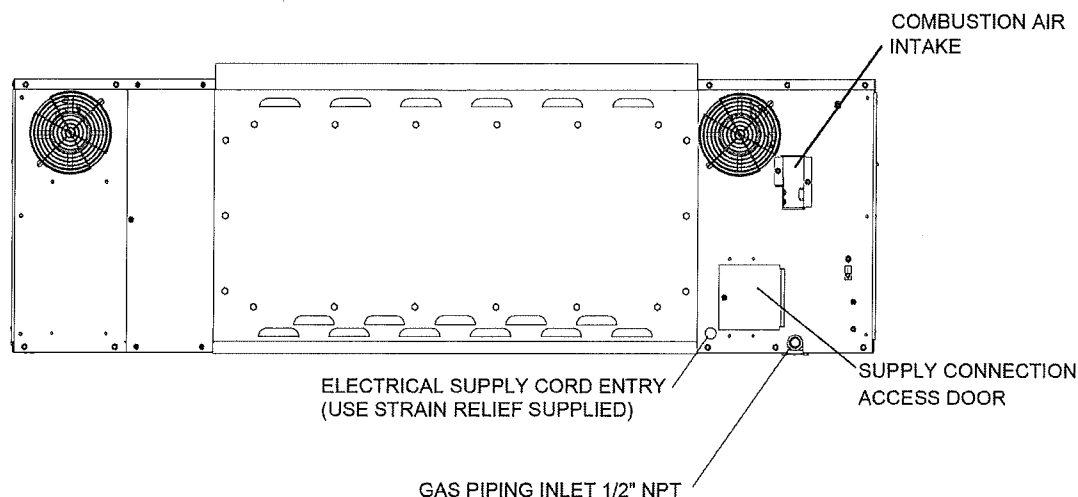

on the oven serial plate. The location of the serial plate is shown in Figure 1-1 (in Section 1, [Description](#)).

A fused disconnect switch or a main circuit breaker (customer furnished) **MUST** be installed in the electric supply line for each oven cavity. It is recommended that the switch/circuit breaker have Lockout/Tagout capability.

The supply conductors must be of the size and material (copper) recommended. Refer to the wiring diagram inside the machinery compartment of the oven. Electrical specifications are also listed on the oven's serial plate and in Table 1-3, [Electrical Specifications](#) (in Section 1, [Description](#)).

The oven requires a ground connection to the oven ground screw. For gas ovens, the screw is located in the electrical junction box (see Figure 2-14). If necessary, have the electrician supply the ground wire. *Do NOT use the wiring conduit or other piping for ground connections.*

Incoming electrical power lines are fed through the strain-relief fitting, shown in Figure 2-14. The electrical supply connections are made inside the electrical junction box. The power lines then connect to the oven circuits through safety switches located inside the machinery compartment and each blower motor compartment. These switches interrupt electrical power to the oven when the Machinery Compartment Access Panel is opened, OR when the rear panel is removed.

Connection

Refer to the wiring diagram inside the machinery compartment of the oven to determine the correct connections for the electrical supply lines. Connect the supply as indicated on the wiring diagram.

CAUTION: *The terms of the oven's warranty require all start-ups, conversions and service work to be performed by a Middleby Marshall Authorized Service Agent.*



VII. GAS SUPPLY

CAUTION: *DURING PRESSURE TESTING NOTE ONE OF THE FOLLOWING:*



1. The oven and its individual shutoff valve must be disconnected from the gas supply piping system during any pressure testing of that system at test pressure in excess of ½ psi (3.45 kPa).
2. The oven must be isolated from the gas supply piping system by closing its individual manual shutoff valve during any pressure testing of the gas supply piping system at test pressure equal to or less than ½ psi (3.45 kPa).
3. If incoming pressure is over 14" W.C. (35mbar), a separate regulator **MUST** be installed in the line BEFORE the individual shutoff valve for the oven.

WARNING: *To prevent damage to the control valve regulator during initial turn-on of gas, it is very important to open the manual shutoff valve very slowly.*



After the initial gas turn-on, the manual shutoff valve must remain open except during pressure testing as outlined in the above steps or when necessary during service maintenance.

A. Gas Utility Rough-In Recommendations

The following gas system specifications are **STRONGLY RECOMMENDED**. Deviating from these recommendations may affect the baking performance of the oven.

Gas Meter

- One or two cavities: 350 cfh meter
- Three oven cavities: 750 cfh meter

Gas Line

- DEDICATED LINE from the gas meter to the oven
- 1-1/2"(38.1mm) pipe for natural gas
- 1-1/2"(38.1mm) pipe for propane
- Maximum length: 2002 (61m). Each 90°elbow equals 7 feet (2.13m) of pipe.

B. Connection

Check the oven's gas supply requirements before making the gas utility connection. Gas supply requirements are listed on the oven's serial plate and in Table 1-4. Gas Orifice and Pressure Specifications (in Section 1, Description).

Check the serial plate to determine the type of gas (Propane or Natural) to be used with the oven.

Refer to the instructions in the gas hose package (included in the Installation Kit) before connecting the gas line. One gas line connection method is shown in Figure 2-18; however, compliance with the applicable standards and regulations is mandatory.

Inlet, regulated, and pilot gas pressure readings can be taken using a digital tube manometer at the tap location shown in Figure 2-19. Figure 2-19 shows the burner assembly and Figure 2-21 shows the gas valve.

NOTE: The installation must conform with local codes or in the absence of local codes, with the National Fuel Gas Code, ANSI Z223.1-latest edition.

Certain safety code requirements exist for the installation of gas ovens; refer to the beginning of Section 2 for a list of the installation standards. In addition, because the oven is equipped with casters, the gas line connection shall be made with a connector that complies with the Standard for Connectors for Movable Gas Appliances, ANSI Z21.69 (in U.S.A.), as well as a quick-disconnect device that complies with the Standard for Quick-Disconnect Devices for Use With Gas Fuel, ANSI Z21.41 (in U.S.A.).

C. Gas Conversion

Where permitted by local and national codes, it is possible to convert ovens from natural to propane gas, or from propane to natural gas. Use the appropriate Middleby Gas Conversion Kit for the specific oven model.

CAUTION: *The terms of the oven's warranty require all start-ups, conversions and service work to be performed by a Middleby Authorized Service Agent.*

D. PS636 Propane Conversion

Two items have to be changed, to change the oven to LP:

1. Replace main orifices.
2. Adjust main gas regulator per instructions below.

Disconnect the manifold union closest to the main burner, and remove the manifold assembly (four screws). Slide out the manifold assembly (leaving the ignition and sense wires connected). Replace the main orifices.

Replace the main orifices on the manifold assemblies with the LP units, and replace the manifold assembly. Reconnect the union.

E. Adjusting the Maximum Pressure Setting

1. Disconnect pressure feedback connection (if applicable).
2. Connect a suitable pressure gauge to pipe line or to outlet pressure tap of gas control concerned, to measure burner pressure (measuring point must be as near to burner as possible).

Figure 2-18. Flexible Gas Hose Installation

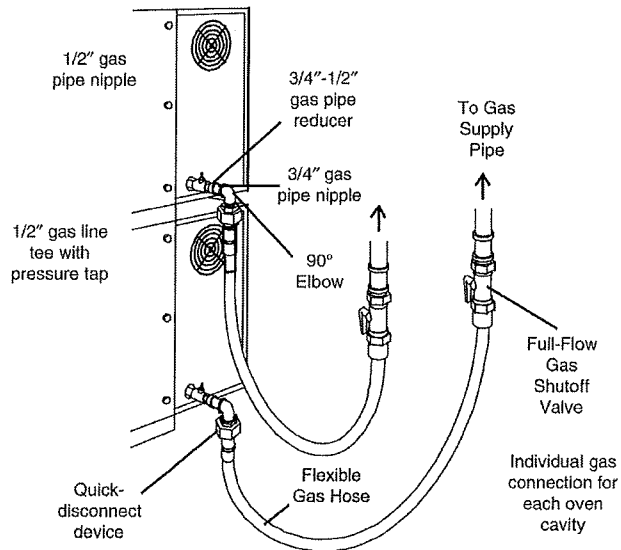
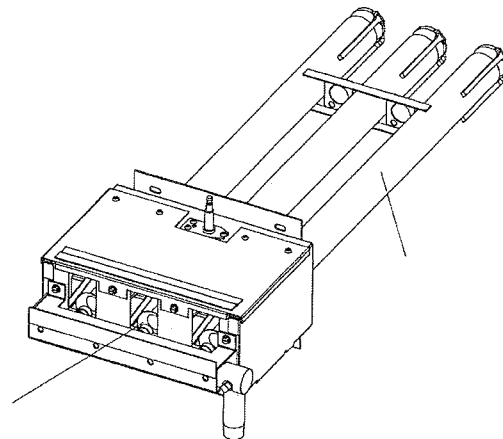
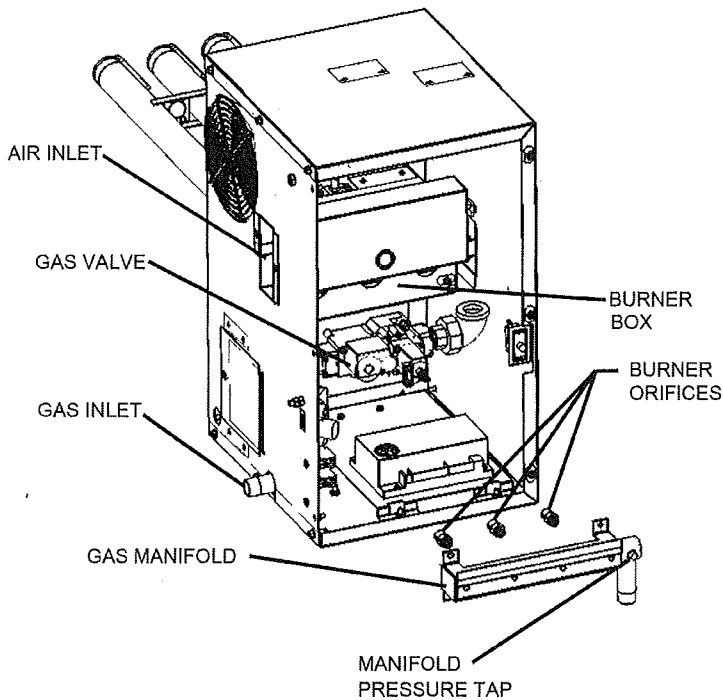

Figure 2-19. Gas Burner Assembly



3. Make sure that the appliance is in operation and the Moduplus® coil is energized with maximum current.
4. If maximum rate pressure needs adjustment, use an 8 mm wrench to turn adjustment screw for maximum pressure setting (clockwise to increase or counter-clockwise to decrease pressure), until the desired maximum outlet pressure is obtained.
5. Disconnect electrical connection of the Moduplus®.
6. Check minimum pressure setting and readjust if necessary. (See Adjusting Minimum Pressure Setting for proper adjusting procedure.)
7. Reconnect pressure feedback connection (if applicable).
8. If minimum and maximum pressures are set, wire the Moduplus® in circuit.
9. Close pressure tap screw.

Figure 2-20. Burner Assembly



F. Adjusting the Minimum Pressure Setting

1. Disconnect pressure feedback connection (if applicable).
2. Connect a suitable pressure gauge to pipe line or to outlet pressure tap of gas control concerned, to measure burner pressure (measuring point must be as near to burner as possible).
3. Disconnect electrical connection of the Moduplus®.
4. Energize operator, set control in operation and wait until an outlet pressure is recorded on pressure gauge.
5. If minimum rate pressure needs adjustment, use an 8 mm wrench to turn adjustment screw for minimum pressure setting (clockwise to increase or counter-clockwise to decrease pressure), until the desired minimum outlet pressure is obtained.
6. Check if main burner lights easily and reliable at minimum pressure.
7. Reconnect pressure feedback connection (if applicable).
8. Close pressure tap screw.

G. Checkout

After any adjustment, set appliance in operation and observe through a component cycle to ensure that burner system components function correctly.

NOTE: The installer **MUST** verify oven operation prior to putting oven into service.

H. Maintenance

It is recommended to check yearly the minimum and the maximum setting and readjust them if necessary.

Figure 2-21. Gas Valve

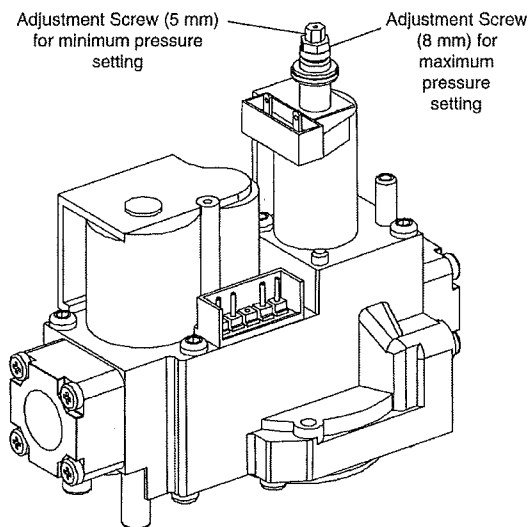

SECTION 3 - FEATURES & OPERATION

PS636 CONTROL KEYS

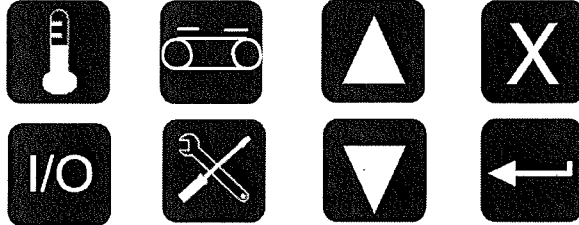

"ON/OFF" KEY: > QUICK PRESS BRINGS OVEN TO ACTIVE, "ON" MODE.

> PRESS & HOLD WILL PUT OVEN INTO "OFF" MODE.
IF TEMP IS OVER 200F THE BLOWERS WILL REMAIN
ON UNTIL THE OVEN TEMP DROPS BELOW 200F.



"TEMPERATURE" KEY: > QUICK PRESS DISPLAYS ACTUAL TEMPERATURE.

> PRESS & HOLD UNTIL DISPLAY FLASHES. ALLOWS
CHANGE TO SET TEMPERATURE.



"BELT" KEY: > QUICK PRESS DISPLAYS ALTERNATE FRONT AND BACK BELT
SPEEDS.

> PRESS & HOLD UNTIL DISPLAY FLASHES. ALLOWS
CHANGE TO BELT SPEED.



"UP/DOWN" KEYS: > PRESS UP OR DOWN TO CHANGE NUMBER VALUES OR
CHANGE PARAMETER.



"TOOLS" KEY: PRESS (WHEN OFF) TO ENTER "SETUP" OR "TEST" SCREENS



"CANCEL" KEY: > QUICK PRESS CANCELS LAST ACTION & RETURNS TO
LAST SCREEN OR OPERATION.

> PRESS & HOLD TO SHUT OVEN OFF.



"RETURN" KEY: > QUICK PRESS STARTS OVEN FROM OFF MODE.

> ENTERS & SAVES CHANGED PARAMETER VALUE.

PS636G DISPLAY FEATURES

STATUS INDICATOR:

"BAKING" appears when the oven is in baking mode. No text here indicates that the oven is in IDLE mode

SETPOINT:

Set point (baking) temperature is displayed here.

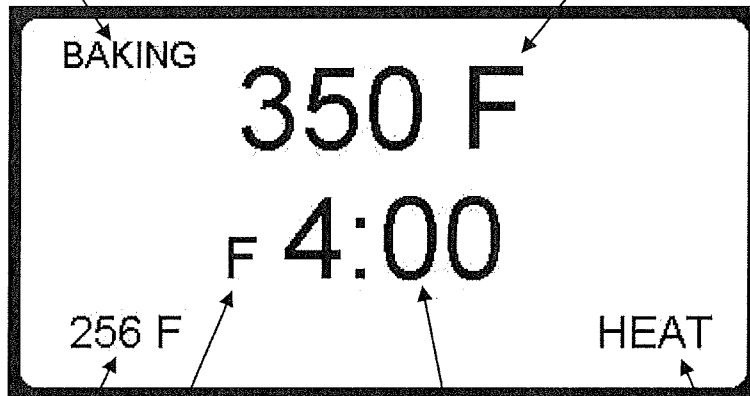

BELT DISPLAYED:

"F" indicates FRONT belt time is being displayed. "B" indicates that the BACK belt time is being displayed. If no letter appears the belt times are identical.

HEAT STATUS:

Alternating display indicates: "HEAT" - heat relay is energized "30 %" - "percent of heat" signal from the control to the gas valve

ACTUAL TEMPERATURE:

Actual temperature of the oven is displayed here. If it is not displayed, pressing the TEMPERATURE key momentarily will show the actual temperature for 15 seconds.

BELT SPEED:

Displays time in minutes and seconds that it takes for the belt to travel the length of the baking chamber.

CONTROL FEATURES

The PS636G control performs a variety of functions, including:

- Temperature control
- Belt speed control
- Upper/lower blower speed setting
- Energy management
- Oven diagnostics & system testing
- Conveyor speed calibration

The oven control will have power delivered to it and initialize when the oven is connected to the power supply. Upon initialization, the control will briefly display its "WOW OVEN" splash screen, then proceed to OFF mode.

STARTING THE OVEN





Turn the ON-OFF switch







to the ON position

then, press the  button. The oven will start and the operating display will appear on the screen. The blowers will begin and the blower proving switches will engage, permitting the heat circuit relay to engage. The gas ignition module will begin its cycle and ignite the three inshot burners.

ADJUSTING THE TEMPERATURE

To adjust the set temperature, press and hold the  button until the set temperature display flashes. Press the  or  arrow until the desired set temperature is displayed. Press the  button to set and save the new temperature value. If  button is not pressed, the new temperature will be present only until the oven is turned OFF. The previously used set temperature will appear when the oven is turned ON again.

ADJUSTING THE BELT TIME

To adjust the belt time, press and hold the  button until the belt time display flashes. Press the  or  button until the desired belt time is displayed. Press the  button to set and save the new time value. If the  button is not pressed, the new time will be present only until the oven is turned OFF. The previously used set temperature will appear when the oven is turned ON again.

If the belt times differ, the display will indicate the belt time with a letter (F or B) preceding the time to indicate FRONT or BACK conveyor belt. Pressing the  button momentarily will alternate the time display between the FRONT and BACK conveyor belt times. If the times are made the same, the time will be displayed without any letter in front of the time value.

TURNING THE OVEN OFF

Turn the ON-OFF switch



to the OFF position

If the oven is below 200°F the display will show "WOW OVEN" screen. If the oven is above 200°F, the display will show "COOL DOWN" and the blowers will run at a preset cool down speed until the oven temperature falls below 200° at which point the oven will go to the OFF mode. In the OFF mode, the screen will display the "WOW OVEN" screen for a one minute period after which the screen backlight will shut off. The oven will stay in this condition until it is started again, with no outputs energized.

ENERGY MANAGEMENT

The PS636 reduces energy usage in two ways over most competitive ovens:

- Modulating gas control
- IDLE / BAKING mode control (Energy Saving Mode)

The modulating gas valve within the oven controls pressure of the delivered gas to the burners to increase or reduce the energy input as needed to maintain temperature instead of cycling a gas valve on and off. This is a more efficient and accurate way of controlling the temperature and eliminates the losses associated with the ON/OFF cycling control.

The PS636 like other Middleby WOW ovens has an idle mode that places the blowers at a reduced speed during non-baking periods. Reducing the blower speed reduces the volume of air requiring heating and thus reduces energy usage in these non-baking times. A photo eye sensor at the entrance side of the baking chamber detects when food is placed on the belt and brings the oven up to the higher (baking) blower speed, increasing the amount of convection air needed to cook products faster. When the product passes the photo eye, the controller begins a preset timed period that insures the product will pass fully through the oven before the oven returns to the IDLE mode. With this energy management scheme, the oven provides the increased convection heat transfer needed for fast baking, without the energy penalty during non-baking times. This functionality is fully automatic and requires no user interaction.

III. TROUBLESHOOTING GUIDE

SYMPTOM	POSSIBLE CAUSES	SOLUTIONS
Nothing displayed on controller	<ol style="list-style-type: none"> 1. Power not connected 2. Main breaker not on 	<ol style="list-style-type: none"> 1. Check plug at wall 2. Check main breaker
Control display is dim and the WOW OVEN image can be seen	Control is in OFF/STANDBY mode.	No problem – the control backlight turns off when the oven is not turned on for use.
Oven not baking properly	<ol style="list-style-type: none"> 1. Settings have been changed 2. Kitchen airflow conditions affecting the bake 	<ol style="list-style-type: none"> 1. Confirm correct values and check that the oven is set properly (time and temperature) 2. Eliminate air cross-currents in area
Conveyor noticeably running at the wrong speed	Time settings have been changed	Confirm correct values and correct control settings
Conveyor not moving	<ol style="list-style-type: none"> 1. Something has jammed the conveyor 2. Circuit breaker (behind control panel) has tripped 	<ol style="list-style-type: none"> 1. Turn power off. Locate and remove jam item. 2. Check for and clear jam. Reset breaker on right control door
"IGNITION LOCKOUT" on display	<ol style="list-style-type: none"> 1. Gas not turned on to oven 2. Burner has stopped running 	<ol style="list-style-type: none"> 1. Turn on manual valve on supply to oven 2. Turn the oven off and back on again to clear the notification and relight
"BAKING" indication goes on and off in upper left corner of the control display	Oven is cycling normally. BAKING indication comes on upon triggering the photo eye.	No problem – the timed baking cycle automatically starts when product breaks the photo eye beam and stops after product leaves the baking chamber.
"BAKING" indicator does not occur when product is placed on conveyor belt.	<ol style="list-style-type: none"> 1. Photo eye not adjusted correctly 2. Photo eye not functioning properly 	Have manger turn off "Energy Mode" until service can adjust or repair photo eye.

NOTE: If the remedial measures above do not successfully resolve the issue, or the issue is not listed above, contact the Middleby Customer Care Center at 847-429-7852

SECTION 4 - MAINTENANCE

WARNING

Before ANY cleaning or servicing of the oven, perform the following procedure:

1. Switch off the oven and allow it to cool. Do NOT service the oven while it is warm.
2. Turn off the electric supply circuit breaker(s) and disconnect the electric supply to the oven.
3. If it is necessary to move a gas oven for cleaning or servicing, disconnect the gas supply before moving the oven.

When all cleaning and servicing is complete:

1. If the oven was moved for servicing, return the oven to its original location.
2. If the restraint cable was disconnected to clean or service the oven, reconnect it at this time.
3. Reconnect the gas supply.
4. Reconnect the electrical supply.
5. Turn on the full-flow gas safety valve. Test the gas line connections for leaks using approved leak test substances or thick soap suds.
6. Turn on the electric supply circuit breaker(s).
7. Perform the normal startup procedure.

WARNING

Possibility of injury from moving parts and electrical shock exists in this oven. Switch off and lockout/tagout the electric supply BEFORE beginning to disassemble, clean, or service any oven. Never disassemble or clean an oven with the BLOWER (⊗) switch or any other circuit of the oven switched on.

CAUTION

NEVER use a water hose or pressurized steam-cleaning equipment when cleaning this oven. To avoid saturating the oven insulation, DO NOT use excessive amounts of water. DO NOT use a caustic oven cleaner, which can damage the bake chamber surfaces.

NOTE

ANY replacement parts that require access to the interior of the oven may ONLY be replaced by a Middleby Marshall Authorized Service Agent. It is also strongly recommended that the 3-Month Maintenance and 6-Month Maintenance procedures in this section be performed ONLY by a Middleby Marshall Authorized Service Agent.

I. MAINTENANCE - DAILY

- A. Check that the oven is cool and the power is disconnected, as described in the warning at the beginning of this Section.
- B. Clean ALL of the cooling fan grills and vent openings with a stiff nylon brush. Refer to Figure 4-1 for the locations of the grills and vents.
- C. Clean the outside of the oven with a soft cloth and mild detergent.
- D. Check that ALL cooling fans are operating properly.

CAUTION: If a cooling fan is not operating correctly, it must be replaced IMMEDIATELY. Operating the oven without adequate cooling can seriously damage the oven's internal components.



- E. Clean the conveyor belts with a stiff nylon brush. This is more easily accomplished by allowing the conveyor to run while you stand at the exit end of the conveyor. Then, brush the crumbs off the conveyor as it moves.
- F. Remove and clean the crumb trays. If necessary, refer to Figure 2-16 (in Section 2, [Installation](#)) when replacing the crumb trays into the oven.
- G. Clean the window in place.

Figure 4-1. Cooling Vents and Grills

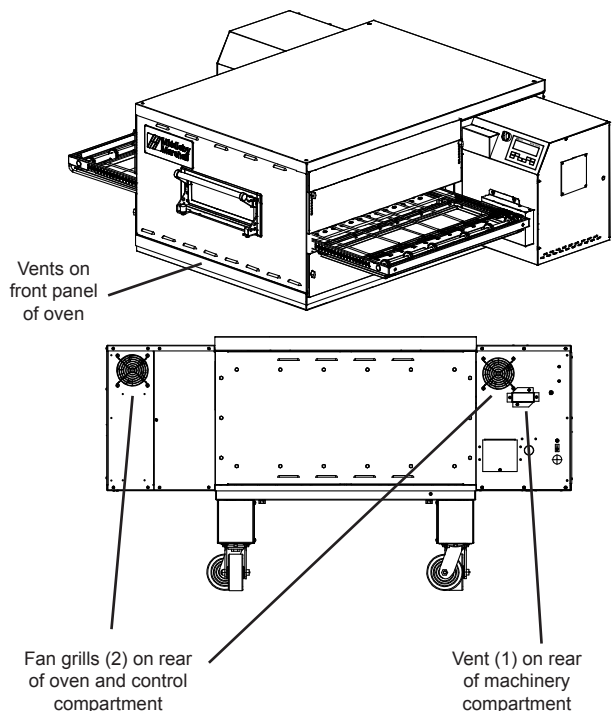

II. MAINTENANCE – MONTHLY

NOTE: When removing the conveyor, refer to Figure 2-12 (in Section 2, Installation).

- A. Check that the oven is cool and the power is disconnected, as described in the warning at the beginning of this Section.
- B. Remove the crumb trays from the oven.
- C. Lift the drive end of the conveyor slightly, and push it forward into the oven. This removes the tension from the drive chain. Then, remove the drive chain from the conveyor sprocket.
- D. Slide the conveyor out of the oven, folding it as it is removed.
- E. Remove the end plugs from the oven. The end plugs are shown in Figure 1-1 (in Section 1, Description).
- F. Slide the air fingers and blank plates out of the oven, as shown in Figure 4-2. **AS EACH FINGER OR PLATE IS REMOVED, WRITE A "LOCATION CODE" ON IT WITH A MARKER** to make sure that it can be reinstalled correctly.

Example of markings:

(Top Row)	T1	T2
(Bottom Row)	B1	B2

- G. Disassemble the air fingers as shown in Figure 4-3. **AS EACH FINGER IS DISASSEMBLED, WRITE THE "LOCATION CODE" FOR THE FINGER ON ALL THREE OF ITS PIECES.** This will help you in correctly reassembling the air fingers.

CAUTION: *Incorrect reassembly of the air fingers will change the baking properties of the oven.*



- H. Clean the air finger components and the interior of the baking chamber using a vacuum cleaner and a damp cloth. Refer to the boxed warnings at the beginning of this Section for cleaning precautions.
- I. Reassemble the air fingers. Then, replace them in the oven, using the "location guide" as a guide.
- J. Replace the end plugs on the oven.
- K. Reassemble the conveyor into the oven. If the drive sprocket was removed when installing the conveyor, replace it at this time.
- L. Reattach the drive chain.
- M. Check the tension of the conveyor belt as shown in Figure 2-14 (in Section 2, Installation). The belt should lift between 3 - 4" (75-100mm). **DO NOT OVERTIGHTEN THE CONVEYOR BELT.** If necessary, the belt tension can be adjusted by turning the conveyor adjustment screws, located at the idler (right) end of the conveyor.
- N. Replace the crumb trays.

Figure 4-2. Removing Air Fingers and Plates

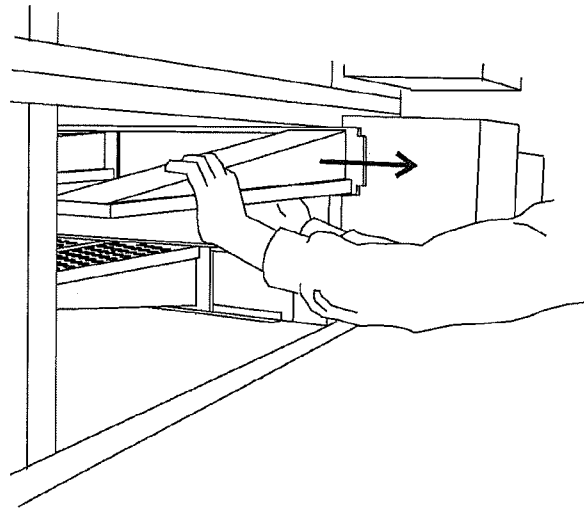
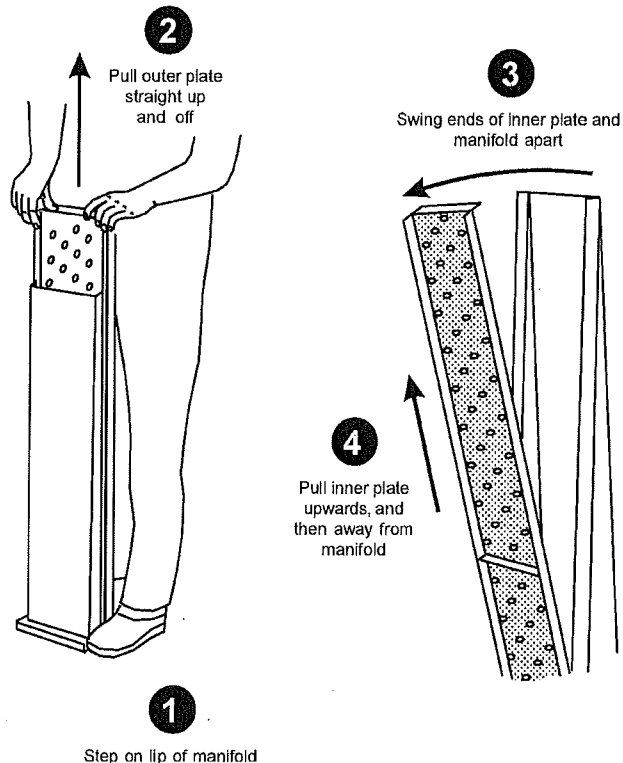
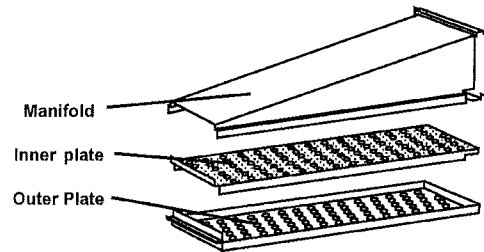

Figure 4-3. Disassembling the Air Fingers



III. MAINTENANCE – EVERY 3 MONTHS

- A. Check that the oven is cool and the power is disconnected, as described in the warning at the beginning of this Section.
- B. Vacuum both of the blower mounts, and their surrounding compartments, using a shop vacuum.
- C. Tighten all electrical terminal screws.
- D. **Split Belt Disassembly and Cleaning**
 1. Refer to Part D, Conveyor Installation, in the Installation section of this Manual. Then, remove the following components from the oven:
 - Conveyor end stop
 - Crumb trays
 - Chain cover
 - Drive chains
 - End plugs
 - Conveyor assembly
 2. Remove the master links from each conveyor belt. Then, roll the belts up along the length of the conveyor to remove them from the frame.
 3. Remove the two conveyor adjustment screws from the idler end of the conveyor frame, as shown in Figure 4-4.
 4. Remove the idler shaft assembly from the conveyor.
 5. Pull apart the two sections of the idler shaft.
 6. Clean the shafts thoroughly using a rag. Then, lubricate both the extended shaft and the interior of the hollow shaft using a light food-grade lubricant. **DO NOT** lubricate the shafts using WD40 or a similar product. This can cause the shafts to wear rapidly.
 7. Before reassembling the shafts into the conveyor frame, check that they are oriented properly.

Figure 4-4. Disassembling the idler shaft

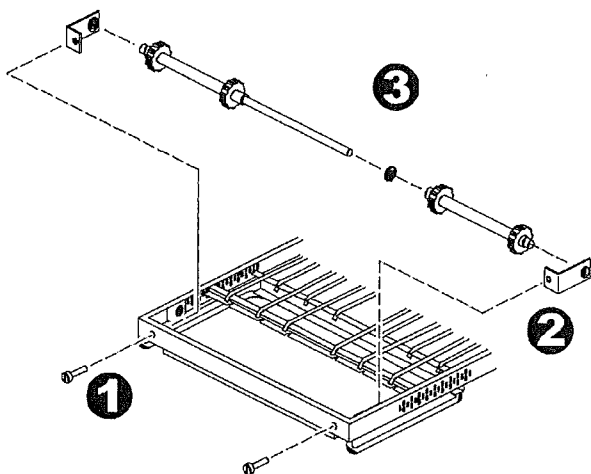

8. Reassemble the idler shaft into the conveyor. Make sure that the bronze washer is in place between the two sections of the shaft. See Figure 4-4.
9. Replace the conveyor adjustment screws as shown in Figure 4-4. To allow the conveyor belt to be reinstalled later, do not tighten the screws at this time.
10. Loosen the set screw on both of the conveyor drive sprockets. Then, remove the sprockets from the shaft.
11. Check the conveyor configuration as follows:

High-speed conveyors are equipped with large flange bearings at both ends of the shaft, as shown in Figure 4-5. For these conveyors, remove the two screws that hold each bearing to the conveyor frame. With the screws removed, lift the end of the shaft at the front of the oven, and pull the entire assembly free of the conveyor frame.

Standard conveyors are equipped with bronze bushings mounted on spacers at both ends of the shaft, as shown in Figure 4-5. For these conveyors, remove the two screws that hold the bracket to the conveyor frame. With the screws removed, lift the end of the shaft at the front of the oven, and pull the entire assembly free of the conveyor frame. The brackets will be removed along with the drive shaft assembly.
12. Disassemble and lubricate the two sections of the drive shaft as described for the idler shaft, above.
13. Before reassembling the shafts into the conveyor frame, check that they are oriented properly.
14. Reassemble the drive shaft into the conveyor. Make sure that the bronze washer is in place between the two sections of the shaft. See Figure 4-4.
15. Replace the drive sprockets. Reassemble the belts and master links onto the conveyor.
16. Reinstall the end plugs and conveyor onto the oven.
17. Reattach the drive chains. Replace the chain cover.
18. Check the tension of the conveyor belt as shown in Figure 2-14 (in Section 2, Installation). The belt should lift about 1" (25mm). If necessary, adjust the belt tension by turning the conveyor adjustment screws.
19. Replace all components onto the oven.

Figure 4-5. Drive shaft configurations

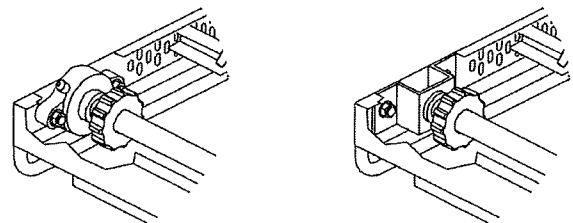

Figure 4-6. Disassembling the drive shaft

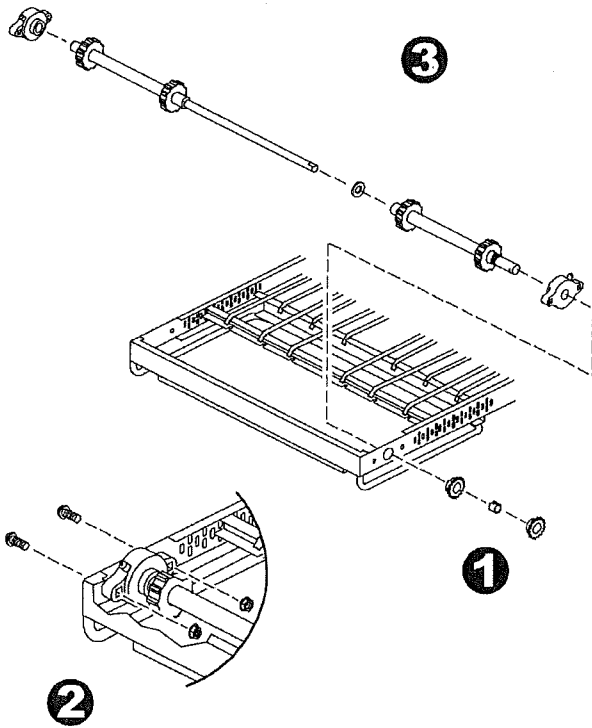
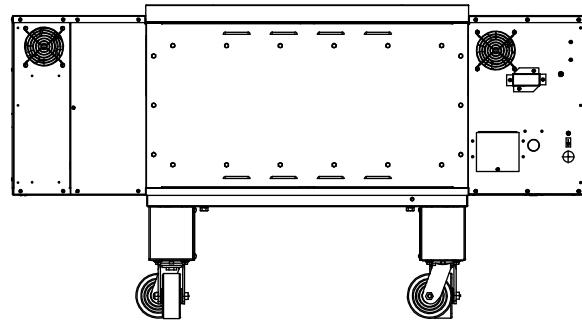

Figure 4-7. Rear panel access



E. Blower Belt

1. Remove the six screws shown in Figure 4-7. Then, remove the rear panel from the oven.
2. Check the blower belt for the proper 1/4" (6mm) deflection at the center, and for cracking or excessive wear.

See Figure 4-7. Overtightening the belt will cause premature bearing failure and possible vibrations. A loose belt may also cause vibrations.

3. If necessary, adjust the tension of the belt by loosening the four motor mounting bolts. Reposition the motor as necessary until the correct 1/4" (6mm) deflection is reached, then tighten the bolts.

IV. MAINTENANCE - EVERY 6 MONTHS

- A. Check that the oven is cool and the power is disconnected, as described in the warning at the beginning of this Section.
- B. For gas ovens, inspect and clean the burner nozzle and the spark electrode assembly.
- C. Check the conveyor drive shaft bushings and spacers. Replace the components if they are worn.

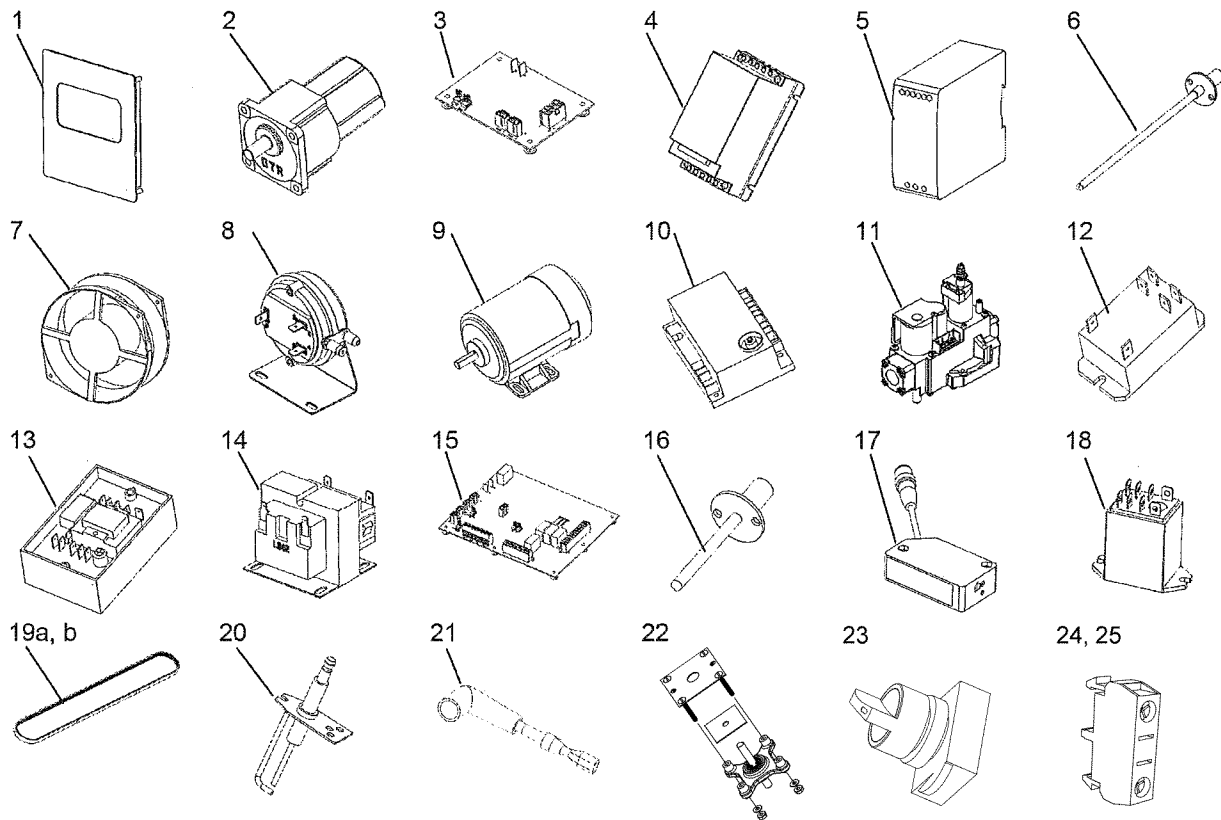

KEY SPARE PARTS PS636 GAS

ITEM	QTY	P/N	DESCRIPTION
1	1	65564	Digital Display, Programmed
2	1	65756	Motor, Conveyor Drive
3	1	65566	Conveyor Control Board
4	1	66065	Inverter, ½ HP (230V Input)
5	1	61186	Power Supply
6	1	33812-1	Thermocouple, Ungrounded 6" (Hi Limit)
7	1	36451	Fan, Cooling
8	2	62044	Air Switch
9	1	65701	Blower Motor, 3/8 HP
10	1	61602	Ignition Module
11	1	60679	Gas Valve (Modulating) w/ flanges and cable
12	1	50794	Relay, 30A (240V coil)
13	1	33983	Hi Limit Thermostat
14	1	32108	Transformer, 240 primary / 24 secondary
15	1	65565	Board, Main – I/O
16	2	60520-2	Thermocouple, 2" Grounded
17	1	60185	Photo Sensor
18	1	59132	Relay, DPDT 24VDC Coil
19a	2	70457	Belt, Blower-to-Blower
19b	2	66382	Belt, Blower-to-motor
20	1	62288	Igniter, Single Rod
21	1	62282	Ignition Cable
22	1	70852	Blower Bearing Assembly
23	1	37168	Switch Operator
24	1	42503	N.O. Contact Block
25	1	67362	N.C. Contact Block

SECTION 5 - WIRING DIAGRAM

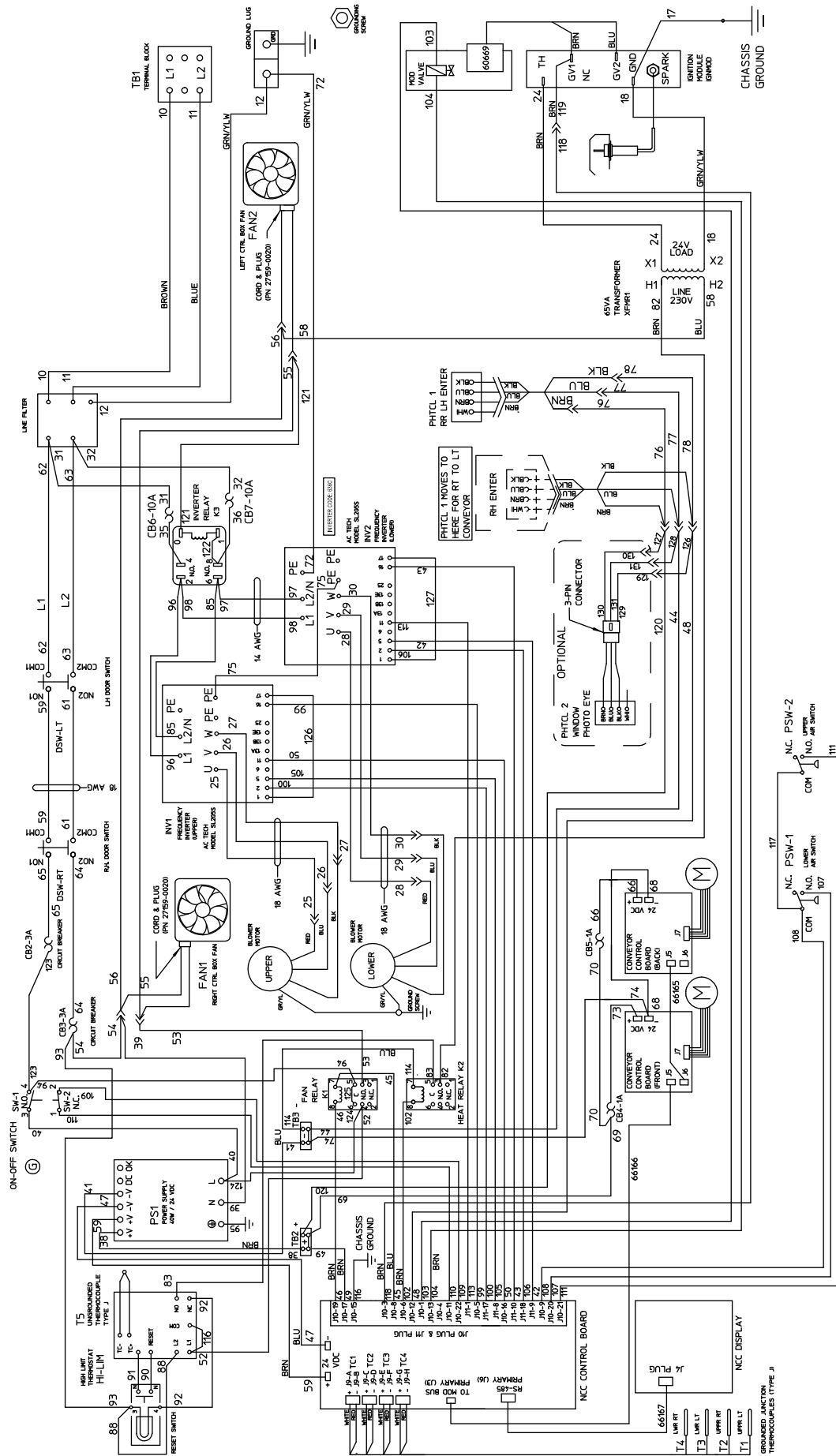

Middleby-Marshall Model Number PS636G208-240 Volt 50/60Hz, 1 Phase

NOTES

NOTES

WARNING

Improper installation, adjustment, alteration, service or maintenance can cause property damage, injury or death. Read the installation, operating and maintenance instructions thoroughly before installing or servicing this equipment.

NOTICE

During the warranty period, ALL parts replacement and servicing should be performed by your Middleby Marshall Authorized Service Agent. Service that is performed by parties other than your Middleby Marshall Authorized Service Agent may void your warranty.

NOTICE

Using any parts other than genuine Middleby Marshall factory manufactured parts relieves the manufacturer of all warranty and liability.

NOTICE

Middleby Marshall reserves the right to change specifications at any time.

CFESA

Commercial Food Equipment Service Association

Middleby is proud to support the Commercial Food Equipment Service Association (CFESA). We recognize and applaud CFESA's ongoing efforts to improve the quality of technical service in the industry.

Middleby Cooking Systems Group • 1400 Toastmaster Drive • Elgin, IL 60120 • USA • (847)741-3300 • FAX (847)741-4406

www.middleby-marshall.com

