

PS638 Series
Electric and Gas Oven
Domestic & Standard Export

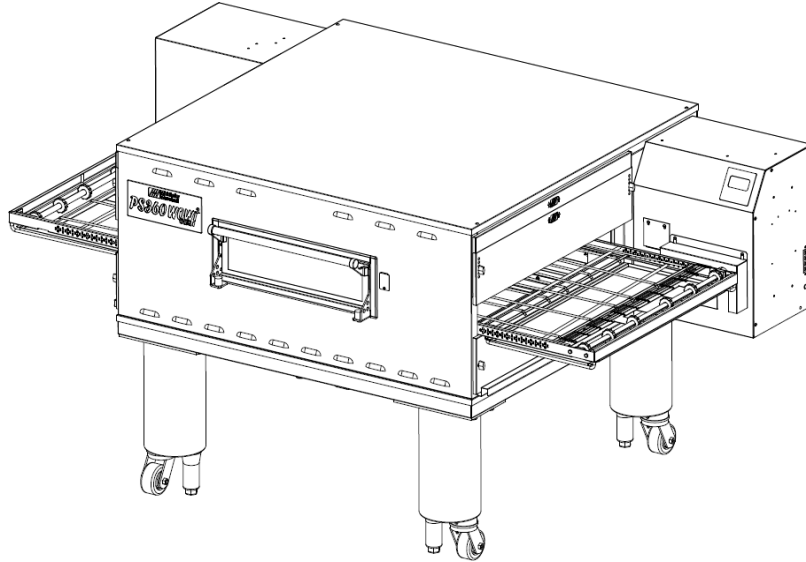

P/N: 74617
Revision G
August 26th, 2022
ENGLISH



PS638 Series Electric and Gas Ovens

Model:

- PS638E Electric
- PS638G Gas

Combinations:

- Single Oven
- Double Oven (Two-Stack)
- Triple Oven (Three-Stack)
- KOF Applications

OWNER'S OPERATING AND INSTALLATION MANUAL

for Domestic & Standard Export Ovens

© 2019 Middleby Marshall Inc.



is a registered trademark of Middleby Marshall, Inc. All rights reserved.



NOTICE:

This Owner's Operating and Installation Manual should be given to the user. The operator of the oven should be familiar with the function and operation of the oven.

This manual must be kept in a prominent, easily reachable location near the oven.

Ovens are shipped from the factory configured for use with Natural gas. If permitted by local, national and international codes, at the time of installation the oven may be converted to Propane gas operation. This conversion requires the use of a Gas Conversion Kit that is supplied with the oven. For CE-approved ovens, the conversion is described in the *Installation* section of this manual. For domestic and standard export ovens, instructions are included in the Gas Conversion Kit.

It is recommended to obtain a service contract with a Middleby Authorized Service Company (ASC).

WARNING

POST IN A PROMINENT LOCATION, THE EMERGENCY TELEPHONE NUMBER OF YOUR LOCAL GAS SUPPLIER AND INSTRUCTIONS TO BE FOLLOWED IN THE EVENT YOU SMELL GAS. INSTRUCTIONS TO BE FOLLOWED IN THE EVENT THE USER SMELLS GAS SHALL BE OBTAINED BY CONSULTING THE LOCAL GAS SUPPLIER. IF THE SMELL OF GAS IS DETECTED, IMMEDIATELY CALL THE EMERGENCY PHONE NUMBER OF YOUR LOCAL GAS COMPANY. THEY WILL HAVE PERSONNEL AND PROVISIONS AVAILABLE TO CORRECT THE PROBLEM.

WARNING

DO NOT SPRAY AEROSOLS IN THE VICINITY OF THIS APPLIANCE WHILE IT IS IN OPERATION.

FOR YOUR SAFETY

DO NOT STORE OR USE GASOLINE OR OTHER FLAMMABLE VAPORS OR LIQUIDS IN THE VICINITY OF THIS OR ANY OTHER APPLIANCE.

WARNING: IMPROPER INSTALLATION, ADJUSTMENT, ALTERATION, SERVICE OR MAINTENANCE CAN CAUSE PROPERTY DAMAGE, INJURY OR DEATH. READ THE INSTALLATION, OPERATING AND MAINTENANCE INSTRUCTIONS. THOROUGHLY BEFORE INSTALLING OR SERVICING THIS EQUIPMENT.

MESURE DE SÉCURITÉ

NE PAS ENTREPOSER NI UTILISER D'ESSENCE NI AUTRES VAPEURS OU LIQUIDES INFLAMMABLES À PROXIMITÉ DE CET APPAREIL OU DE TOUT AUTRE APPAREIL!

AVERTISSEMENT: L'INSTALLATION, LE RÉGLAGE, LA MODIFICATION, LA RÉPARATION OU L'ENTRETIEN INCORRECTS DE CET APPAREIL PEUVENT CAUSER DES DOMMAGES MATÉRIELS, DES BLESSURES OU LA MORT. LIRE ATTENTIVEMENT LES INSTRUCTIONS D'INSTALLATION, DE FONCTIONNEMENT ET D'ENTRETIEN AVANT DE PROCÉDER À SON INSTALLATION OU ENTRETIEN.

IMPORTANT

An oven electrical wiring diagram is located in this manual and inside the machinery compartment.

IMPORTANT

It is the customer's responsibility to report any concealed or non-concealed damage to the freight company. Retain all shipping materials until it is certain that the equipment has not suffered concealed shipping damage.

NOTICE

CONTACT YOUR MIDDLEBY AUTHORIZED SERVICE COMPANY TO INSTALL AND PERFORM MAINTENANCE AND REPAIRS AND IF NECESSARY TO CONVERT EQUIPMENT FOR USE WITH OTHER GASES. AN AUTHORIZED SERVICE COMPANY DIRECTORY IS SUPPLIED WITH YOUR OVEN AND AVAILABLE HERE: WWW.MIDDLEBY-MARSHALL.COM

NOTICE

Using parts other than genuine Middleby Marshall factory manufactured parts relieves the manufacturer of all warranty and liability.

NOTICE

Middleby Marshall (Manufacturer) reserves the right to change specifications at any time.

NOTICE

The equipment warranty is not valid unless the oven is installed, started, and demonstrated under the supervision of a factory authorized installer.

NOTICE

THE EQUIPMENT IS ONLY FOR PROFESSIONAL USE AND SHALL BE USED BY QUALIFIED PERSONNEL.

RETAIN THIS MANUAL FOR FUTURE REFERENCE

TABLE OF CONTENTS

SECTION 1 - DESCRIPTION	Page
I. OVEN USES.....	1
II. OVEN COMPONENTS.....	1
A. Conveyor Motor Drive	
B. Crumb Pans	
C. Conveyor	
D. End Plugs	
E. Eyebrows	
F. Window	
G. Control Cabin Door	
H. Serial Plate	
I. Control Panel	
J. Photo Sensor	
K. Optional Door Photo Sensor	
L. Circuit Breaker Resets	
M. Gas Burner	
N. Blowers	
O. Air Fingers	
III. OVEN SPECIFICATIONS	2
A. Dimensions	2
B. General Specifications	2
C. Electrical Specifications	2A
D. Gas Specifications	2B
SECTION 2 - INSTALLATION	
I. GENERAL	3
II. BASE/TOP KITS & EQUIPMENT.....	4
A. SINGLE OVEN BASE/TOP KIT	5
B. DOUBLE OVEN BASE/TOP KIT	6
C. TRIPLE OVEN BASE/TOP KIT	7
III. OVEN LAYOUTS	
A. Single Oven Stacked	8
B. Double Oven Stacked.....	10
IV. VENTILATION SYSTEM.	12
A. Requirements.....	12
B. Recommendations	12
C. Other Ventilation Concerns.....	12
V. ASSEMBLY	
A. Top Panel and Base Pad Assembly.....	13
B. Stacking	14
C. Restraint Cable Installation	14
D. Conveyor Installation.....	15
E. Final Assembly	16
VI. ELECTRICAL SUPPLY	17
VII. GAS SUPPLY	
A. Gas Rough-In Recommendations....	19
B. Connection... ..	19
C. Gas Conversion.....	19
D. ULPG Conversion	20
E. Adjusting Max Pressure Setting... ..	20
F. Checkout... ..	20
G. Maintenance.....	20
H. Gas Train with Orificed By-Pass	20
I. Gas Specifications.....	21-22

SECTION 3 - OPERATION	
I. DESCRIPTION OF CONTROLS	23
II. NORMAL OPERATION	
A. Daily Oven Start-Up Procedure... ..	24
B. Daily Shut-Down Procedure... ..	24
C. Ignition Sequence of Operation.....	25
D. Energy Management	25
II. OTHER ADJUSTMENTS (MANAGER MODE)	
A. PLC System Control Setup.....	26
B. B.MenuSelect Optional Program	27
IV. TROUBLESHOOTING INFORMATION	
A. Troubleshooting Guide.....	28
B. Alerts, Errors and Remedies.....	29
SECTION 4 - MAINTENANCE	
I. MAINTENANCE – DAILY.....	30
II. MAINTENANCE – MONTHLY.....	31
III. MAINTENANCE – 3 MONTH... ..	32
IV. MAINTENANCE – 6 MONTH... ..	33
V. KEY SPARE PARTS.....	33-34
SECTION 5 – WIRING DIAGRAM	35
SECTION – ASSEMBLY DRAWINGS.....	40

**MIDDLEBY MARSHALL
NO QUIBBLE LIMITED WARRANTY
(U.S.A. ONLY)**

MIDDLEBY MARSHALL HEREINAFTER REFERRED TO AS "THE SELLER", WARRANTS EQUIPMENT MANUFACTURED BY IT TO BE FREE FROM DEFECTS IN MATERIAL AND WORKMANSHIP FOR WHICH IT IS RESPONSIBLE. THE SELLER'S OBLIGATION UNDER THIS WARRANTY SHALL BE LIMITED TO REPLACING OR REPAIRING AT SELLER'S OPTION, WITHOUT CHARGE, ANY PART FOUND TO BE DEFECTIVE AND ANY LABOR AND MATERIAL EXPENSE INCURRED BY SELLER IN REPAIRING OR REPLACING SUCH PART. SUCH WARRANTY SHALL BE LIMITED TO THE ORIGINAL PURCHASER ONLY AND SHALL BE EFFECTIVE FOR A PERIOD OF ONE YEAR FROM DATE OF ORIGINAL INSTALLATION OR 18 MONTHS FROM DATE OF PURCHASE, WHICHEVER IS EARLIER, PROVIDED THAT TERMS OF PAYMENT HAVE BEEN FULLY MET.

This warranty is valid only if the equipment is installed, started, and demonstrated under the supervision of a factory-authorized installer.

Abuse, acts of God, belt jams, cleaning, customer abuse, insufficient utilities, lubrication, maintenance, non-oven related issues, preventative maintenance, or normal maintenance function including adjustment of airflow, burners, conveyor components, door mechanisms, microswitches, pilot burners, thermostats, and replacement of bushings, light bulbs, fuses, indicating lights and wear points, are not covered by this **no quibble limited warranty**.

Seller shall be responsible only for repair or replacement of defective parts performed by Seller's authorized service personnel. Authorized service companies are located in principal cities throughout the contiguous United States, Alaska, and Hawaii. This warranty is valid in the 50 United States and is void elsewhere unless the product is purchased through Middleby International with warranty adder included.

The foregoing warranty is exclusive and in lieu of all other warranties, expressed or implied. There are no implied warranties of merchantability or of fitness for a particular purpose.

The foregoing shall be the Seller's sole and exclusive obligation and Buyer's sole and exclusive remedy for any action, including breach of contract or negligence. In no event shall Seller be liable for a sum in excess of the purchase price of the item. Seller shall not be liable for any prospective or lost profits of the buyer.

This warranty is effective on Middleby Marshall equipment sold on, or after January 1st, 2007.

© 2018 - Middleby Marshall, A Middleby Company.

**MIDDLEBY MARSHALL
OVEN LIMITED WARRANTY
(Non U.S.A.)**

The Seller warrants equipment manufactured by it to be free from defects in material and workmanship for which it is responsible. The Seller's obligation under this warranty shall be limited to replacing or repairing, at Seller's option, without charge, F.O.B. Seller's factory, any part found defective and any labor and material expense incurred by Seller in repairing or replacing such part. Such warranty is limited to a period of one year from the date of original installation or 15 months from date of shipment from Seller's factory, whichever is earlier, provided that terms of payment have been fully met. All labor shall be performed during regular working hours. Overtime premium will be charged to the Buyer.

This warranty is not valid unless equipment is installed, started, and demonstrated under the supervision of a factory-authorized installer.

Normal maintenance functions including lubrication, adjustment of airflow, thermostats, door mechanisms, microswitches, burners and pilot burners, and replacement of light bulbs, fuses, and indicating lights, are not covered by warranty.

Any repair or replacement of defective parts shall be performed by Seller's authorized service personnel. Seller shall not be responsible for any costs incurred if the work is performed by anyone other than the Seller's authorized service personnel.

When returning any part under warranty, the part must be intact and complete, without evidence of misuse or abuse, freight prepaid.

Seller shall not be liable for any consequential damages of any kind which occurs during the course of installation of equipment, or which results from the use or misuse by Buyer, its employees, or others, of the equipment supplied hereunder, at Buyer's sole and exclusive remedy against Seller for any breach of the foregoing warranty or otherwise shall be for the repair or replacement of the equipment or parts thereof affected by such breach.

The foregoing warranty shall be valid and binding upon Seller if and only if Buyer loads, operates and maintains the equipment supplied hereunder in accordance with the instruction manual provided to Buyer. Seller does not guarantee the process of manufacture by Buyer or quality of product to be produced by the equipment supplied hereunder and Seller shall not be liable for any prospective or lost profits of Buyer.

The foregoing shall be Seller's sole and exclusive obligation and Buyer's sole and exclusive remedy for any action, whether in breach of contract or negligence. In no event shall Seller be liable for a sum in excess of the purchase price of the item.

THE FOREGOING WARRANTY IS EXCLUSIVE AND IN LIEU OF ALL OTHER EXPRESS AND IMPLIED WARRANTIES WHATSOEVER, SPECIFICALLY THERE ARE NO IMPLIED WARRANTIES OF MERCHANTABILITY OR FITNESS FOR A PARTICULAR PURPOSE.

SECTION 1 - DESCRIPTION

I. OVEN USES

The PS638 Series Continuous Batch WOW Conveyor Ovens can be used to bake, cook, crisp, dry, heat, or finish a wide variety of products, such as catering, pastries, pizza, pizza-type products, cookies, sandwiches and other items

OVEN COMPONENTS – See Figure 1-1

- A. **Conveyor Drive Motor (inside cabinet):** Moves the Conveyor Belting (65756)
- B. **Crumb Pans:** Catch crumbs and other materials that drop through the conveyor belt. One crumb pan is located at each end of the conveyor belt
- C. **Conveyor:** Moves the food product through the oven.
- D. **End Plugs:** Allow access to the oven's interior.
- E. **Eyebrows:** Can be adjusted to various heights to lessen heat loss to the environment (72709)
- F. **Window (Optional):** Allows the user to access the food products within the baking chamber, or place product into the oven for shorter bake times. (51054)
- G. **Control Cabinet Doors:** Allow access to the oven's control components. No user serviceable parts are located within these cabinets.
- H. **Serial Plate:** Provides specifications for the oven pertinent to installation, operation and maintenance. Refer to *SECTION 2 – INSTALLATION* for details.
- I. **Control Panel (User Interface):** Allows user to adjust temperature, bake time, and top and bottom air flow. Also provides diagnostic messages for oven operation.
- J. **Photo Sensor (Optional):** Puts oven into the Baking Mode when the beam is interrupted by product being placed on the belt (72209).
- K. **Door Photo Sensor (Optional):** Puts oven into the Baking Mode when the beam is interrupted by the front window being opened to insert product.
- L. **Circuit Breaker Resets:** Permits resetting breakers inside control cabinet without opening control door or directly touching the circuit breakers.
- M. **Burner or Heater (inside left control cabinet):** Heat recirculating air within the plenum and oven cavity.
- N. **Blowers (not shown):** Move heated air that recirculates through the oven cavity.
- O. **Fingers (inside oven cavity):** Direct air in controlled fashion to the product being baked through a highly specialized pattern arrangement of extruded holes. See Standard Finger Arrangement (73555)

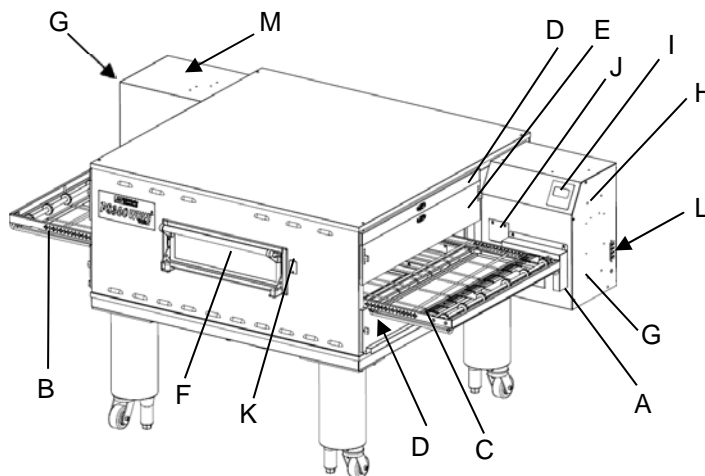
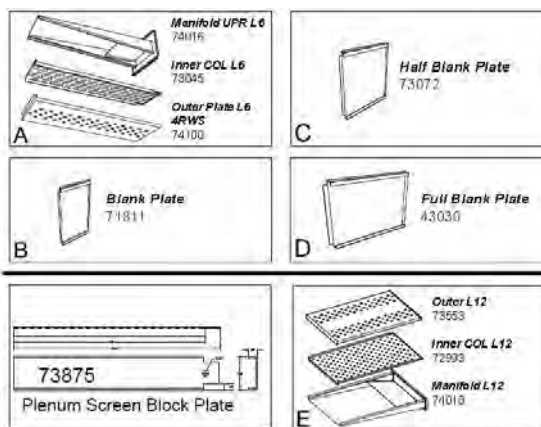
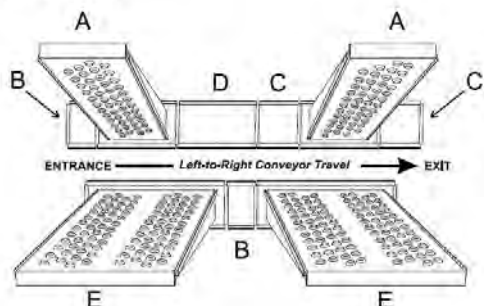

Figure 1-1

Middleby Marshall PS638 L-R

Left-to-Right configuration is shown:
Upper Air Block P/N 73875 (2) Installed in Top Air!
Pressure not to be exceeded.

For Right-to-Left is mirror image



Finger Arrangement P/N 73555, Rev. B, 04/1E

II. OVEN SPECIFICATIONS – PS638E

Table 1-1 Dimensions	Single Oven	Double Oven	Triple Oven
Overall Height	42" (1064 mm)	51.25" (1301 mm)	63.50" (1612 mm)
Overall Depth	50" (1270 mm)	50" (1270 mm)	50" (1270 mm)
Overall Length	65.25" (1656 mm)	65.25" (1656 mm)	65.25" (1656 mm)
Conveyor Width – Belt width is 25" (635mm)	26.9" (683.3 mm)	26.9" (683.3 mm)	26.9" (683.3 mm)

Recommended Minimum Clearances

Rear of Oven to Wall	0" (0 mm)
Right Side of Oven to Wall	0" (0 mm)
Left Side of Oven to Wall	0" (0 mm)

Table 1-2: General Specifications

PS638E

Weight	838 lbs. (380 kg)	1,676 lbs. (760 kg)	2,514 lbs (1,140 kg)
Rated Heat Input (per oven cavity)	22.0 kW (79.2MJ/h)		
Maximum Operation Temperature	600°F (315 C)		
Air Blowers	2 at 2,145 rpm		
Warm-up Time	15 minutes to 500°F		

Table 1-3: Electrical Specifications

Main Blower & Element Voltage	Control Circuit Voltage	Phase	Frequency	Current Draw	Poles	Wires
208 VAC	24VDC	3φ	50/60 Hz	80 Amps	3	4 Wire 3 hot, 1 ground
240 VAC	24VDC	3φ	50/60 Hz	70 Amps	3	4 Wire 3 hot, 1 ground
380 VAC	24VDC	3φ	50/60 Hz	50 Amps	4	5 Wire 3 hot, 1 neutral, 1 ground

Table 1-4: Heater Amperage

Voltage	kW	Amp	Average Amps		
208 VAC	22.0	63	63	63	60
240 VAC	22.0	54	54	54	51
380 VAC	22.0	39	39	35	35
380 VAC CE	18.0	37.4	37.4	27.4	27.4

NOTE

Wiring Diagrams are contained in Section 5 of this Manual and are also located inside the oven control compartment. Additional electrical information is provided on the oven's serial plate.

I. OVEN SPECIFICATIONS – PS638G

Table 1-1 Dimensions	Single Oven	Double Oven	Triple Oven
Overall Height	42" (1066.8 mm)	51.25" (1301.8 mm)	63.50" (1612.9 mm)
Overall Depth	50" (1270 mm)	50" (1270 mm)	50" (1270 mm)
Overall Length	65.25" (1657 mm)	65.25" (1657 mm)	65.25" (1657 mm)
Conveyor Width – Belt width is 25" (635mm)	26.9" (683.3 mm)	26.9" (683.3 mm)	26.9" (683.3 mm)

Recommended Minimum Clearances

Rear of Oven to Wall	0" (0 mm)
Right Side of Oven to Wall	0" (0 mm)
Left Side of Oven to Wall	0" (0 mm)

Table 1-2: General Specifications PS638G

Weight	820 lbs. (372 kg)	1,640 lbs (744 kg)	2,460 lbs (1,488 kg)
Rated Heat Input (per oven cavity)	89,000BTU/hr (93.9MJ/h, 26.1 kW)		
Maximum Operation Temperature	600°F (315 C)		
Air Blowers	2 at 1,650 rpm		
Warm-up Time	15-20 minutes to 500°F		

Table 1-3: Electrical Specifications

Main Blower Voltage	Control Circuit Voltage	Phase	Frequency	Current Draw	Poles	Wires
208/240 VAC, 3φ	24VDC	1	50-60 Hz	4.2/4.0 Amps	2	3 Wire – L1, L2/N & GRND

Table 1-4: Gas Orifice and Pressure Specifications

Gas Type	Main Orifice Diameter	Inlet Pressure	Manifold Pressure	Bypass Orifice
Natural Gas	#39 = 0.0995" (2.527mm) (72023)	7-9" W.C. (1.7 – 2.2 kPa)	3.5" W.C. at manifold (0.87 kPa)	#49 = 0.073" (1.854mm) (59145)
Propane/LI PG	0.0689" (73785) (1.75mm)	12-14" W.C. (3.0-3.5 kPa)	6.0" W.C. at manifold (1.49 kPa)	#55 = 0.052" (1.321mm) (49948)

GAS ORIFICE AND PRESSURE SPECIFICATIONS (PER OVEN CAVITY) – CE OVENS

Gas Type	Main Orifice Diameter	Orifice Size										Orifice Manifold Pressure	Rated Heat Input
		I _{2H}	I _{2L}	I _{2E}	I _{2E+}	I _{3P}	I _{3P}	I _{3B/P}	I _{3B/P}	I _{3B/P}	I ₃₊		
Natural Gas	#39 0.0995" 2.527 mm	20mbar	--	20 mbar	20/25 mbar	--	--	--	--	--	--	3.5" w.c. 8.7 mbar	25.9kW
Natural Gas	#39 0.0995" 2.527 mm	--	25 mbar	--	--	--	--	--	--	--	--	3.5" w.c. 8.7 mbar	25.9kW
Butane G30	0.0689" 1.75mm	--	--	--	--	--	--	28-30/50 mbar	30 mbar	37/50 mbar	28-30 mbar	6.0" w.c. 14.9 mbar	29.2kW
Propane G31	0.0689" 1.75mm	--	--	--	--	37 mbar	50 mbar	--	30 mbar	37/50 mbar	37 mbar	6.0" w.c. 14.9 mbar	25.8kW

NOTE

Wiring Diagrams are contained in Section 5 of this Manual and are also located inside the oven control compartment. Additional electrical information is provided on the oven's serial plate.

THIS MANUAL MUST BE KEPT FOR FUTURE REFERENCE

SECTION 2 - INSTALLATION

I. GENERAL

WARNING – After any conversions, readjustments, or service work on the oven:

- Perform a gas leak test
- Test for proper combustion and gas supply
- Test for correct air supply, particularly to the burner.
- Check that the ventilation system is in operation

WARNING – Keep the appliance area free and clear of combustibles.

WARNING – The oven must be installed on even (level) non-flammable flooring and any adjacent walls must not be flammable. Recommended minimum clearances are specified in the Description - Section I of this manual.

WARNING – Do not obstruct the flow of ventilation air to and from your oven. There must be no obstruction around or underneath the oven. Constructional changes to the area where the oven is installed shall not affect the air supply to the oven.

CAUTION: To reduce the risk of fire, the appliance is to be mounted on floors of non-combustible construction with noncombustible flooring and surface finish and with no combustible material against the underside thereof, or on noncombustible slabs or arches having no combustible material against the underside thereof, such construction shall in all cases extend not less than 12 inches (304 mm) beyond the equipment on all sides.

CAUTION: For additional installation information, contact your local Authorized Service Agent.

NOTE – There must be adequate clearance between the oven and combustible construction. Clearance must also be provided for servicing and proper operation.

NOTE – An electrical wiring diagram for the oven is located inside the machinery compartment.

NOTE: All aspects of the oven installation, including placement, utility connections, and ventilation requirements, must conform to any applicable local, national, and/or international codes. These codes supersede the requirements and guidelines provided in this manual.

NOTE: In the USA, the oven installation must conform to local codes. In the absence of local codes, gas oven installations must conform to the National Fuel Gas Installation Code, ANSI Z223.1. Gas and electric ovens, when installed must be electrically grounded in accordance with local codes, or in the absence of local codes, with the National Electric Code (NEC), or ANSI/NFPA 70.

NOTE: In Canada, the oven installation must conform to local codes. In the absence of local codes, gas oven installations must conform to the Natural Gas Installation Code, CAN/CGA-B149.1 or Propane Gas Installation Code, CAN/CGA-B149.2, as applicable. Gas and electric ovens, when installed, must be electrically grounded in accordance with local codes, or in the absence of local codes, with Canadian Electrical Code, CSA C22.2.

NOTE: In Australia, the oven installation must conform to AS/NZ5601 and carry local Authority or any other relevant statutory regulations.

II. PS638 OVEN INSTALLATION – BASE/TOP KITS & EQUIPMENT

TYPE OF INSTALLATION	PS638 Installation Kit	Single Oven Kit Base w/ 15" Legs, Casters & Top	Double Oven Kit Base w/ 6" Legs, Casters & Top	Triple Oven Kit Base, Casters & Top
PS638E Single Oven	74121	One (1) PN 71687	--	--
PS638E Double Oven	74121	--	One (1) PN 73754	--
PS638E Triple Oven	74121	--	--	One (1) PN 73556
PS638G Single Gas Oven	74075	One (1) PN 71687	--	--
PS638G Double Gas	74075	--	One (1) PN 73754	--
PS638G Triple Gas	74075	--	--	One (1) PN 73556

LOOSE PARTS & KITS FOR PS638 SERIES OVEN INSTALLATION KITS (PN 74121-E & 74075-G)

GAS OR ELECTRIC	ITEM NUMBER	PART NUMBER	DESCRIPTION	QTY
Gas	1	22361-0001	Flexible Gas Hose 3/4"	1
Both	2	22450-0228	Restraint Cable	1
Gas	3	50546	TAP AND ADAPTER	1
Both	4	72836	Conveyor End Stop	1
Optional	not shown	51054	Glass Door & Handle Assy	1
Both	not shown	73314 & 73315	Crumb Pans	2
Gas	not shown	62307	Manual Ball Gas Valve	1

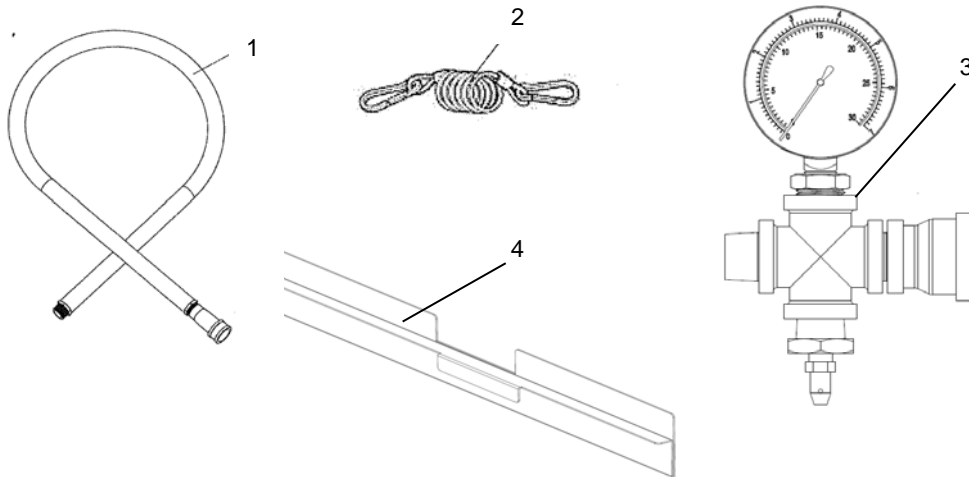

A. P/N: 71687 – SINGLE OVEN BASE & TOP KIT

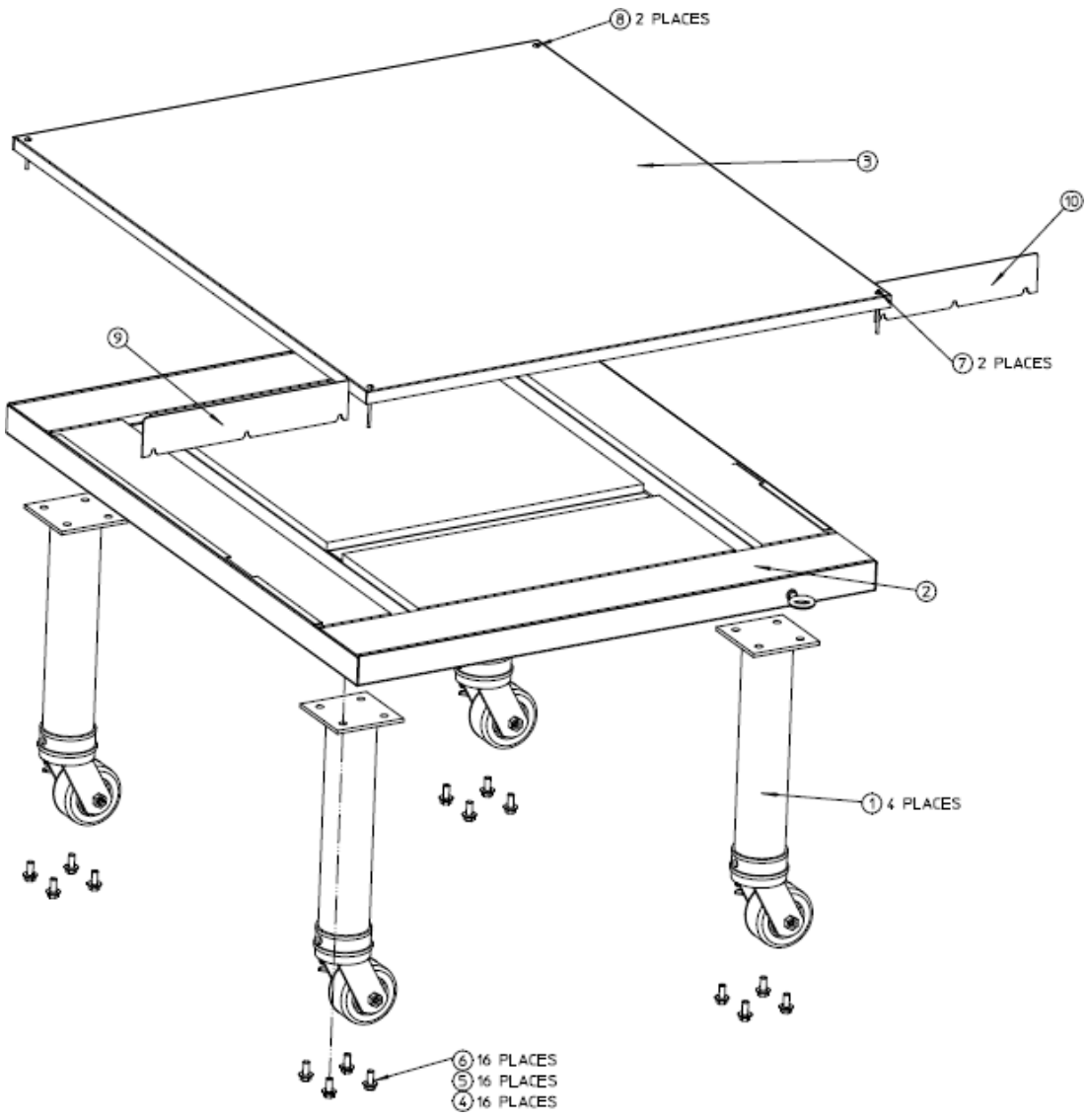

10	1	73771	GUARD,CTRL BOX LH FILLER
9	1	73772	GUARD,CTRL BOX RH FILLER
8	2	71457	SCR,SL TRUS HD SS 10-32X2
7	2	73543	SCR,SL TRUS HD SS 10-32X2.75"
6	16	2000531	SCR,CAP HX HD 3/8-16X1 NP
5	16	21416-0001	WASHER,FLAT SS 3/8
4	16	21422-0001	WASHER,LOCK SPLIT 3/8 ZP
3	1	72655	COVER,TOP PS638
2	1	71688	ASSY,BASE PS638
1	4	66948	LEG,15" COMMON TUBE
ITEM	QTY	PART NO.	DESCRIPTION

B. P/N: 73754 – DOUBLE OVEN BASE & TOP KIT

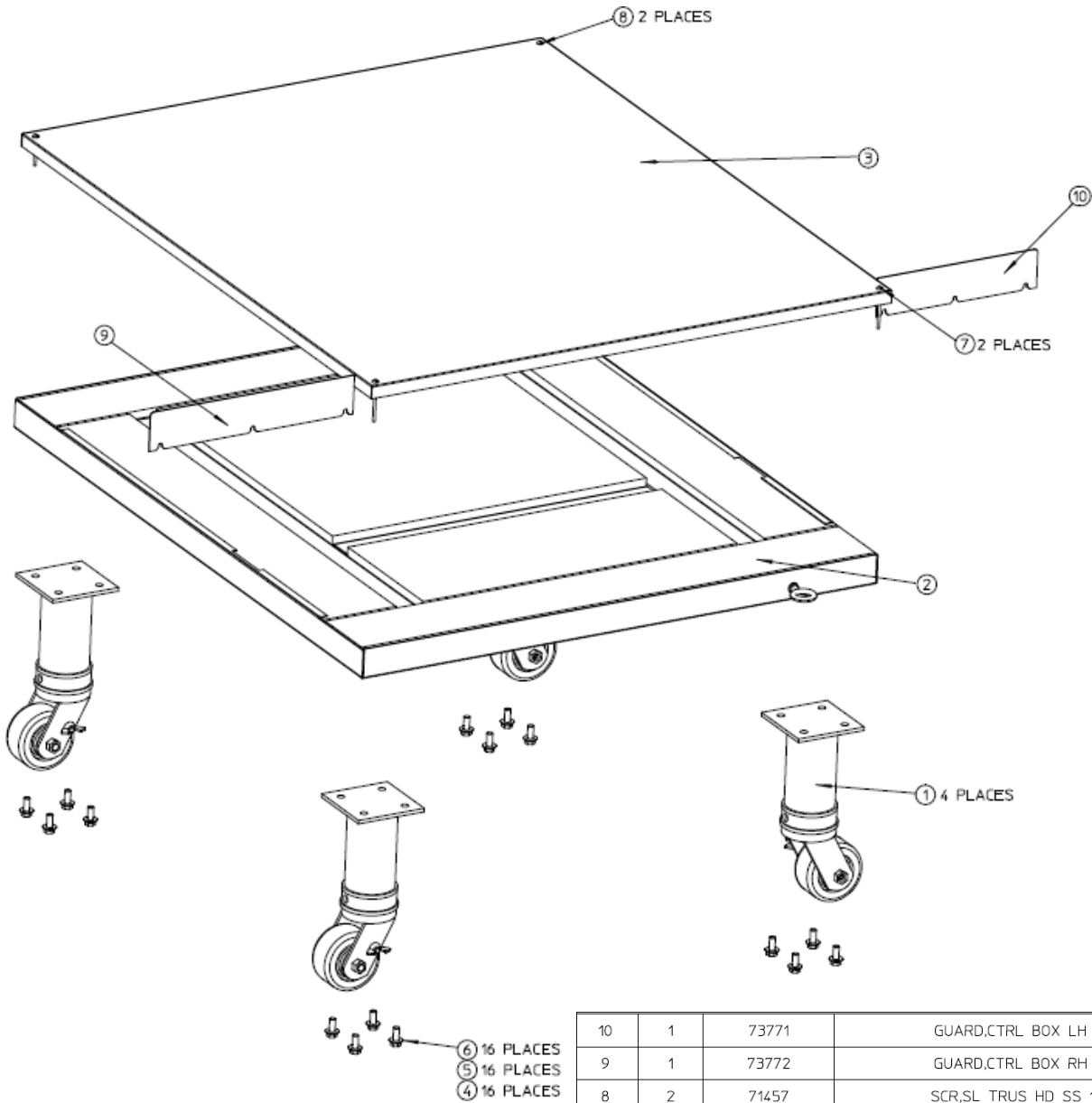

10	1	73771	GUARD,CTRL BOX LH FILLER
9	1	73772	GUARD,CTRL BOX RH FILLER
8	2	71457	SCR,SL TRUS HD SS 10-32X2
7	2	73543	SCR,SL TRUS HD SS 10-32X2,75"
6	16	2000531	SCR,CAP HX HD 3/8-16X1 NP
5	16	21416-0001	WASHER,FLAT SS 3/8
4	16	21422-0001	WASHER,LOCK SPLIT 3/8 ZP
3	1	72655	COVER,TOP PS638
2	1	71688	ASSY,BASE PS638
1	4	66946	LEG,6" COMMON TUBE
ITEM	QTY	PART NO.	DESCRIPTION

C. P/N: 73556 – TRIPLE OVEN BASE & TOP KIT

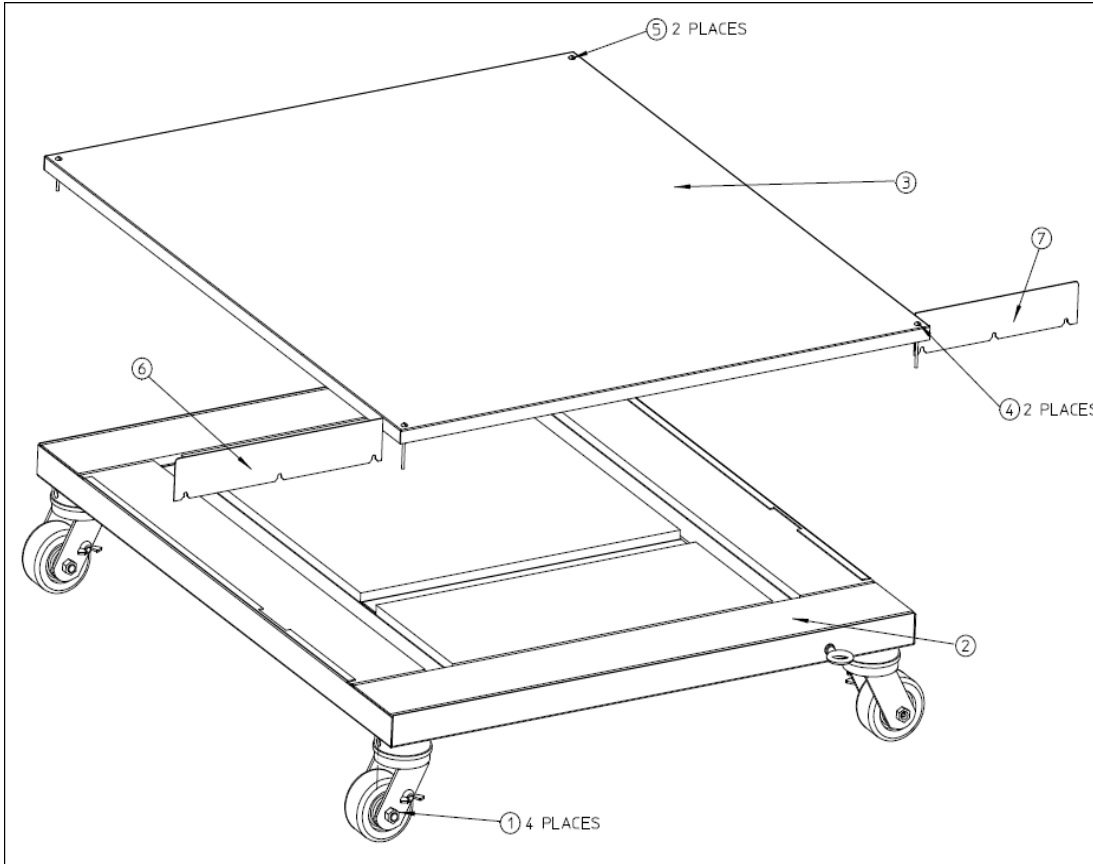

7	1	73771	GUARD,CTRL BOX LH FILLER
6	1	73772	GUARD,CTRL BOX RH FILLER
5	2	71457	SCR,SL TRUS HD SS 10-32X2
4	2	73543	SCR,SL TRUS HD SS 10-32X2.75"
3	1	72655	COVER,TOP PS638
2	1	71688	ASSY,BASE PS638
1	4	58930	CASTER,STUD W/BRAKE 4" WHEEL
ITEM	QTY	PART NO.	DESCRIPTION

**PS638G Series
Direct Gas Fired Conveyor Oven**

NOTE: Drawings show ovens equipped with casters.

PS638G Single Oven

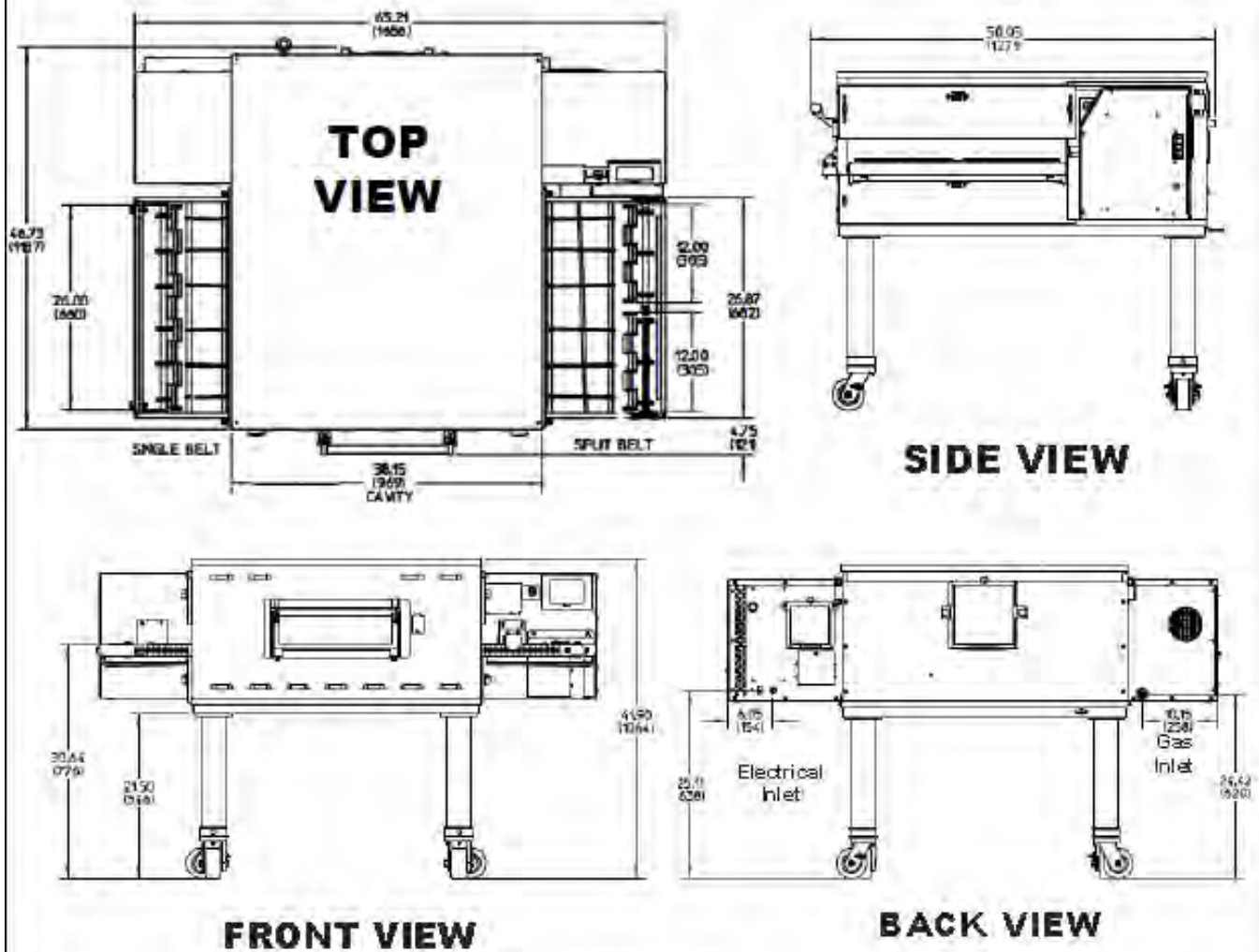

PS638G Rev 3 3/18

III. PS638 OVEN LAYOUTS (cont.)

B. Double and Triple Oven

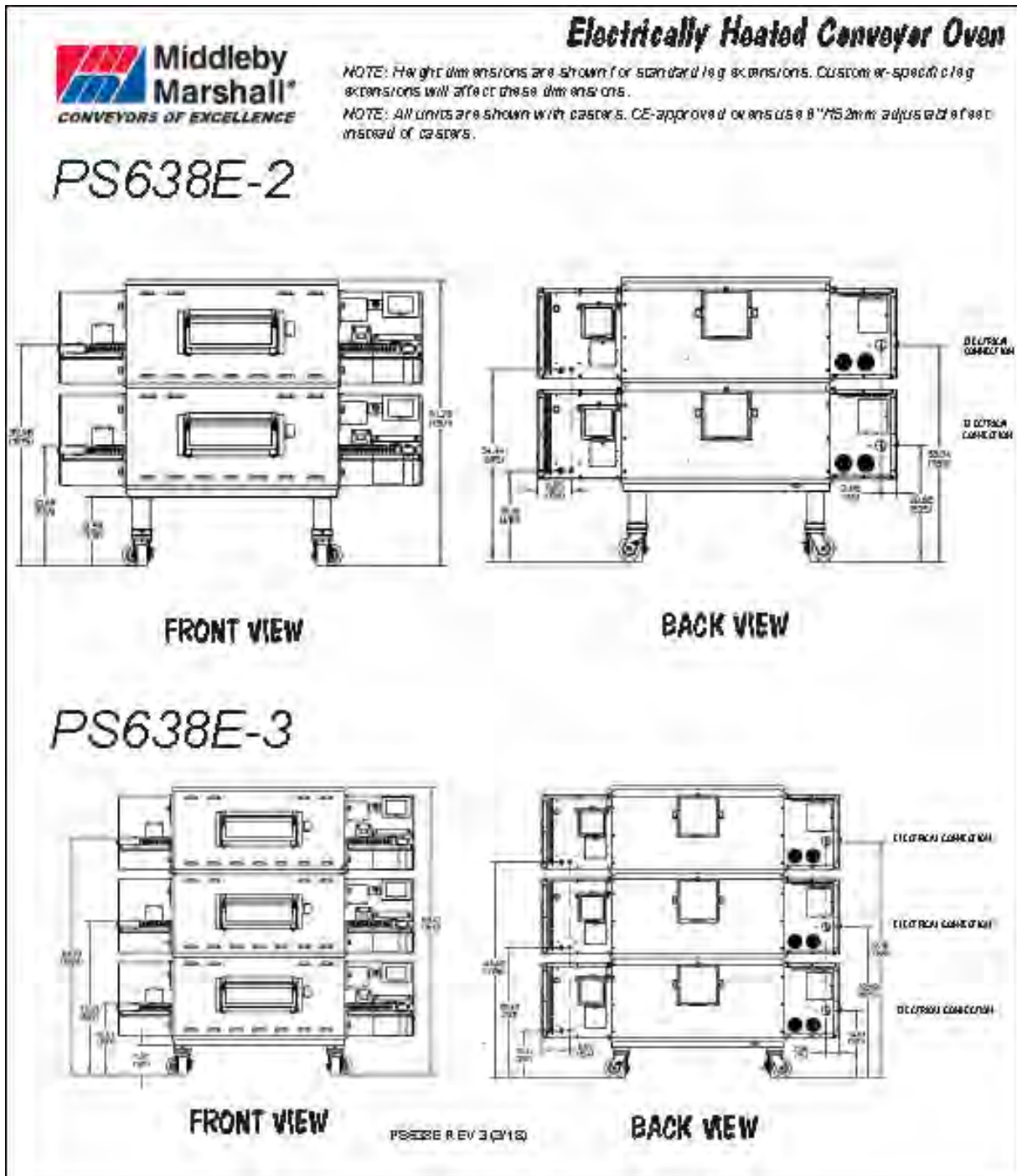

**PS638G Series
Direct Gas Fired Conveyor Oven**

NOTE: Drawings show ovens equipped with casters.

PS638-2 Double Oven

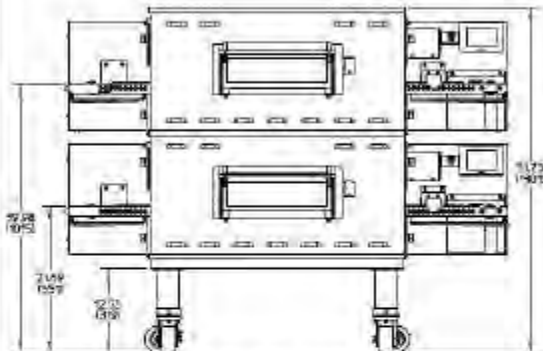

FRONT VIEW

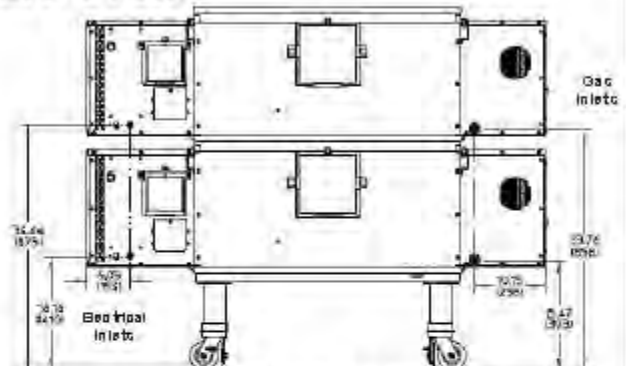

BACK VIEW

PS638-3 Triple Oven

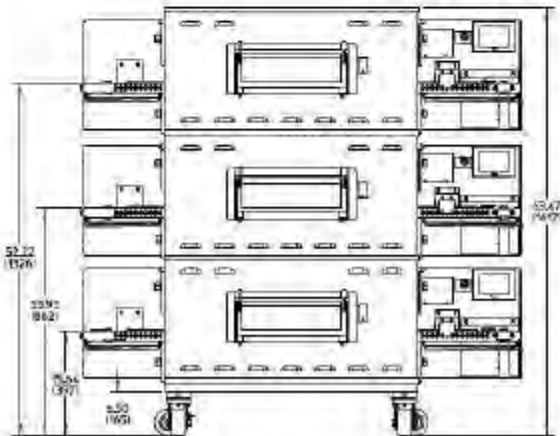

FRONT VIEW

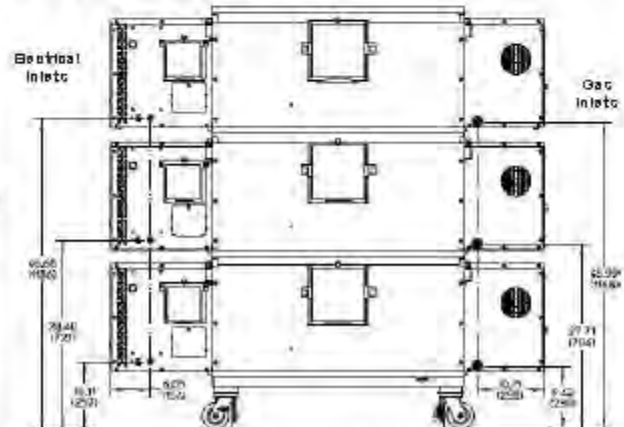

BACK VIEW

PS638G Rev 3/3/18

IV. VENTILATION SYSTEM

IMPORTANT

Where national or local codes require the installation of fire suppression equipment or other supplementary equipment, **DO NOT** mount the equipment directly to the oven.

MOUNTING SUCH EQUIPMENT ON THE OVEN MAY:

- VOID AGENCY CERTIFICATIONS
- RESTRICT SERVICE ACCESS
- LEAD TO INCREASED SERVICE EXPENSES FOR THE OWNER

A. Requirements

CAUTION: Gas oven installations REQUIRE a mechanically driven ventilation system with electrical air sensing control.

A mechanically driven ventilation system is **STRONGLY RECOMMENDED** for electric oven installations.

PROPER VENTILATION OF THE OVEN IS THE RESPONSIBILITY OF THE OWNER.

B. Recommendations

NOTE THAT THE HOOD DIMENSIONS SHOWN IN FIGURE 2-5 ARE RECOMMENDATIONS ONLY. LOCAL, NATIONAL, AND INTERNATIONAL CODES MUST BE FOLLOWED WHEN INSTALLING THE VENTILATION SYSTEM. ANY APPLICABLE CODES SUPERSEDE THE RECOMMENDATIONS SHOWN IN THIS MANUAL. IN AUSTRALIA, COMPLIANCE TO REGULATIONS AS/NZS 5601 IS MANDATORY.

The rate of air flow exhausted through the ventilation system may vary depending upon the oven configuration and hood design. Consult the hood manufacturer or ventilation engineer for these specifications.

To avoid negative pressure condition in the kitchen area, return air must be brought back to replenish the air that was exhausted. A negative pressure in the kitchen can cause heat related problems to the oven components as if there were no ventilation at all. The best method of supplying return air is through the heating, ventilation and air conditioning (HVAC) systems. Through the HVAC system, the air can be temperature-controlled for summer and winter. Return air can also be brought in directly from outside the building, but detrimental effects can result from extreme seasonal hot and cold temperatures from the outdoors.

NOTE: Return air from the mechanically driven system must not blow at the opening of the baking chamber. Poor oven baking performance will result.

C. Other ventilation concerns

1. Special locations, conditions, or problems may require the services of a ventilation engineer or specialist.
2. Inadequate ventilation can inhibit oven performance.
3. It is recommended that the ventilation system and duct work be checked at prevailing intervals as specified by the hood manufacturer and/or HVAC engineer or specialist.

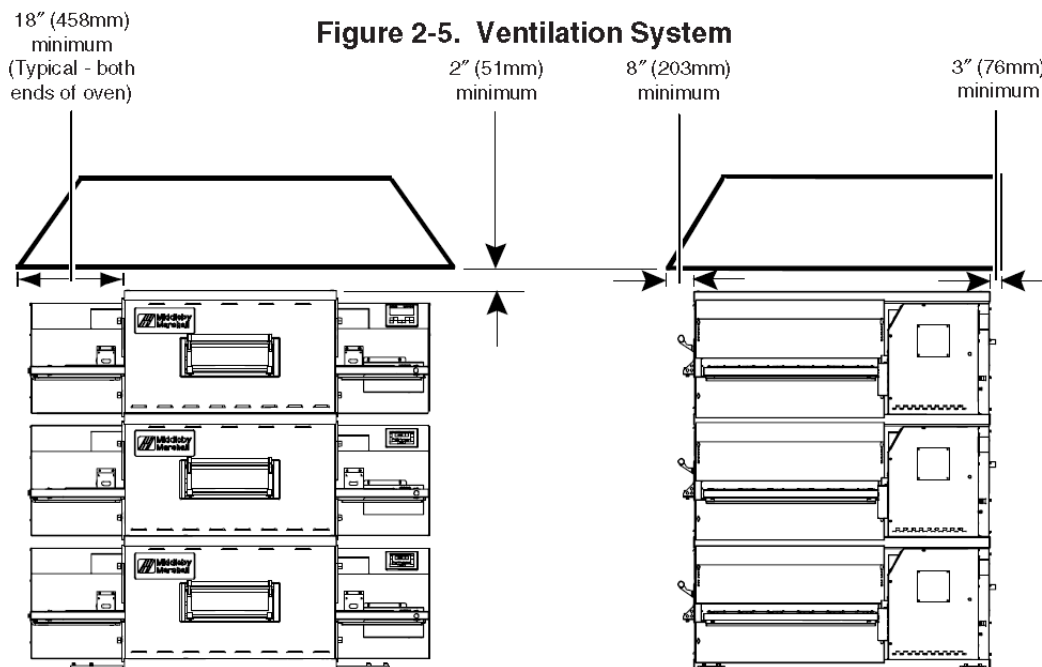

V. ASSEMBLY

A. Top Panel and Base Pad Assembly

1. Install the four leg extensions onto the base pad using the 3/8"-16 x 1" screws, 3/8" flat washers and 3/8" lock washers supplied in the Base Pad Kit. See Figure 2-6. Install the spring clip for the oven restraining cable to the hole in the bottom middle of the base pad, see Oven Base & Top Kit drawings (pages 5-7). This clip will attach to the restraint cable that keeps the oven from moving too far when installed on casters.
2. Install one caster or one adjustable 6" leg onto each leg extension and tighten securely in place.
3. Install the lower oven cavity onto the base pad. See Fig 2-7.
4. For single ovens ONLY:

Install the top panel using the screws included in the base pad kit, as shown in Fig 2-8. Then, skip ahead to Part C, Restraint Cable Installation.

For double or triple ovens:

Continue on to Part B, Stacking. Note that the top panel should NOT be installed for double and triple ovens until after stacking the oven cavities.

Fig 2-6. Leg Extension and Caster Installation

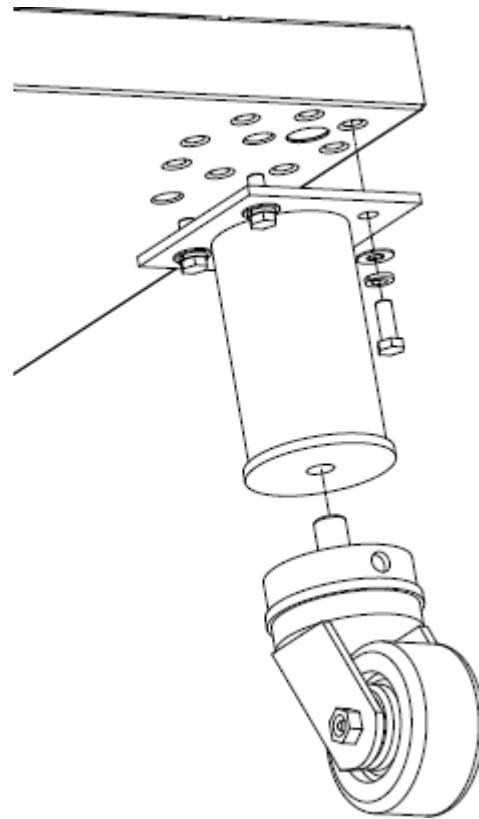

Fig 2-7. Base Pad Installation

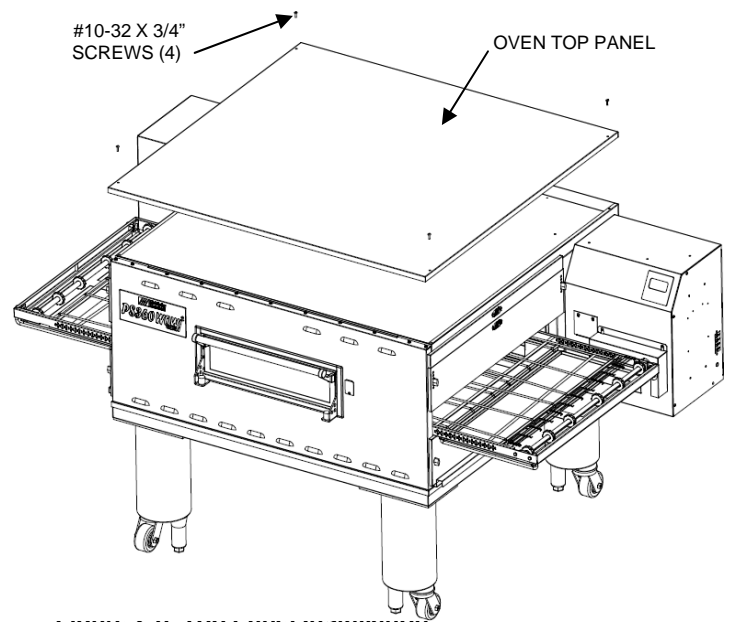
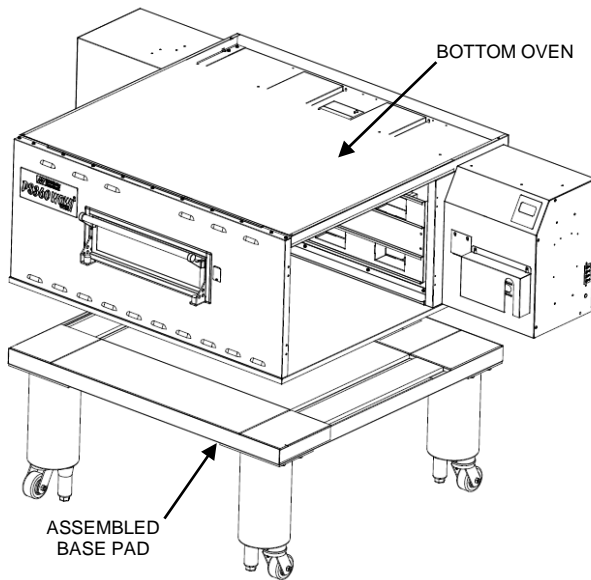

Figure 2-8. Top Panel Installation

NOTE: DO NOT install top panel onto double or triple ovens until AFTER stacking the oven cavities. See Part B, Stacking.

B. Stacking

For single ovens, skip ahead to Part C, Restraint Cable Installation.

IMPORTANT

Middleby Marshall **STRONGLY RECOMMENDS** that the PS638-WOW oven cavities be stacked by **AUTHORIZED PERSONNEL**. Contact your Middleby Marshall Authorized Service Company for complete stacking instructions.

1. Stack an oven cavity on top of the lower oven. Check the following:

- Insulation is installed on the lower oven top.
- All four sides of the lower lip (on the bottom edge of the oven cavity) overlap the top of the lower oven.
- The oven is level.
- The oven is firmly seated and the top insulation layer is installed smoothly and fully covering the metal panel.

See Figure 2-9.

2. For triple ovens, repeat Step 1 to install the top oven cavity.

3. Install the top panel using the screws included in the base pad kit, as shown in

Figure 2-9. Stacking

C. Restraint Cable Installation

Because the oven is equipped with casters, a restraint cable assembly must be installed depending upon the connector and the quick disconnect device or its associated hardware. See Figure 2-10. After connecting the restraint cable, move the oven to its final location. Lock the oven door.

FIGURE 2-10. Top Panel Installation

FIGURE 2-11. Installing the Restraint Cable

The restraint cable is connected to the spring snap located at the back-center of the oven. The other end of the restraint cable is attached to the wall or floor.

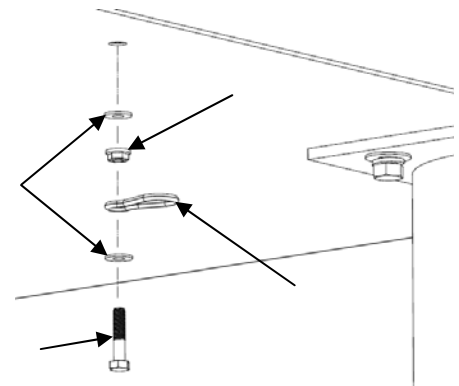
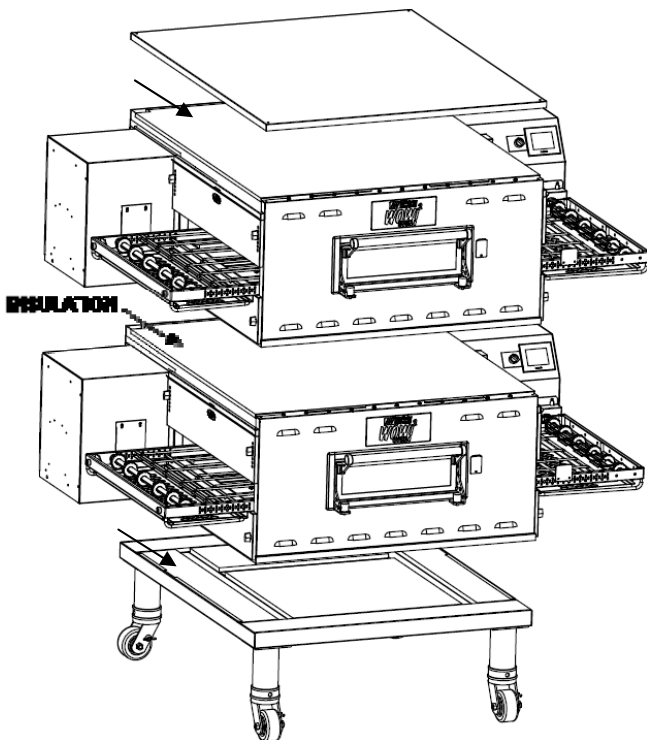
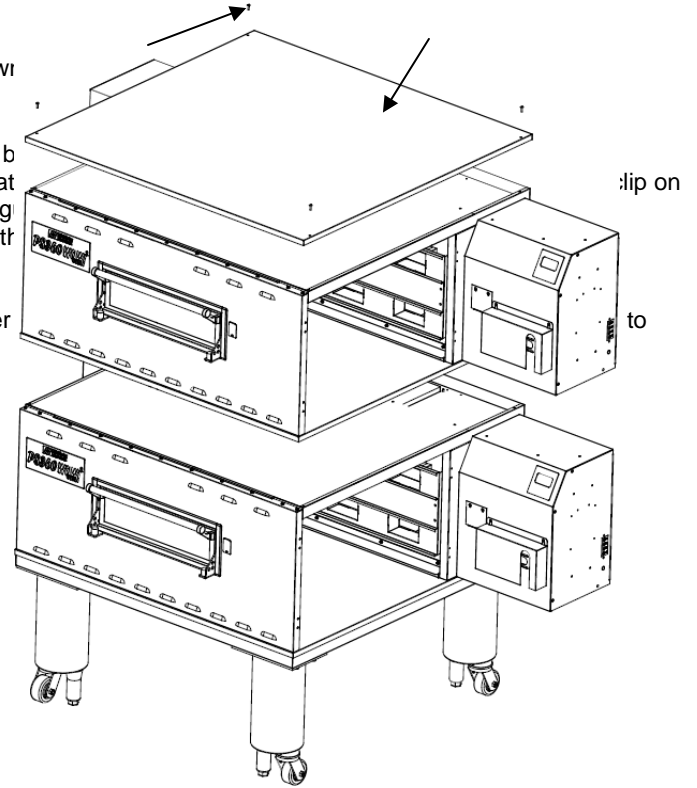

D. Conveyor Installation

1. Unfold the conveyor as shown in Figure 2-12. Then begin to slide the conveyor into the end of the oven. The conveyor can only be installed from the side of the oven where the drive motors are located.
2. Continue moving the conveyor into the oven until the frame protrudes equally from each end of the oven. Check that the crumb tray supports located on the underside of the conveyor frame rest firmly against the lower end plugs, as shown in Figure 2-13.
3. When the conveyor is positioned properly, check for freedom of movement of the conveyor belt by pulling it for about 2 to 3 feet (0.6- 1.0 m) with your fingers. The drive and idler shafts must rotate smoothly, and the belt must move freely without rubbing on the inside of the oven. If not, then re-align the belting.
4. Check the Tension of the conveyor belt as shown in Figure 2-14. The belt should lift about 1" (25mm). **DO NOT OVER TIGHTEN THE CONVEYOR BELT.**

NOTE: If necessary, the belt tension can be adjusted by turning the conveyor adjustment screws, located at the idler (non-control) end of the conveyor. See Figure 2-14.

Figure 2-12. Conveyor Installation

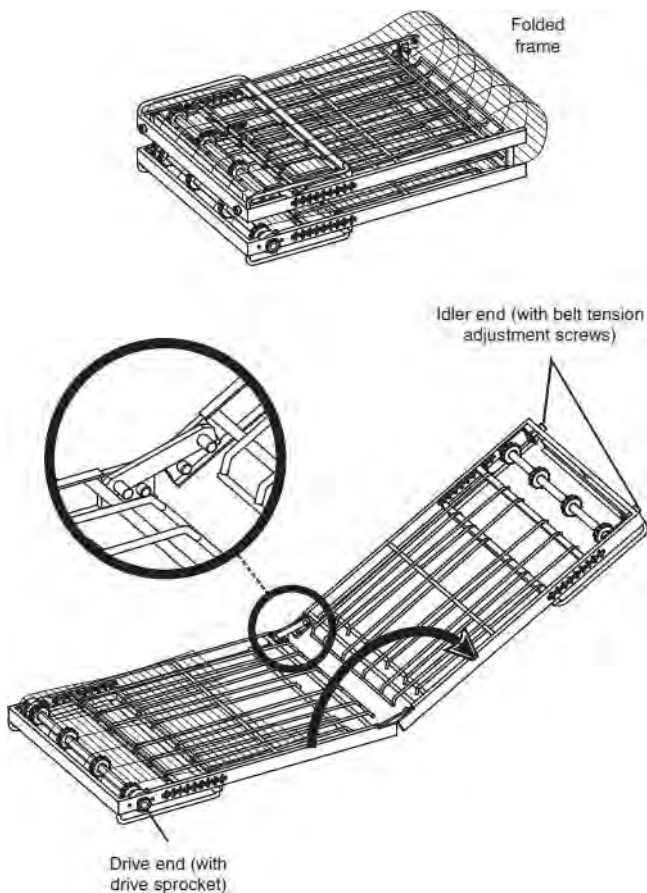

Figure 2-13

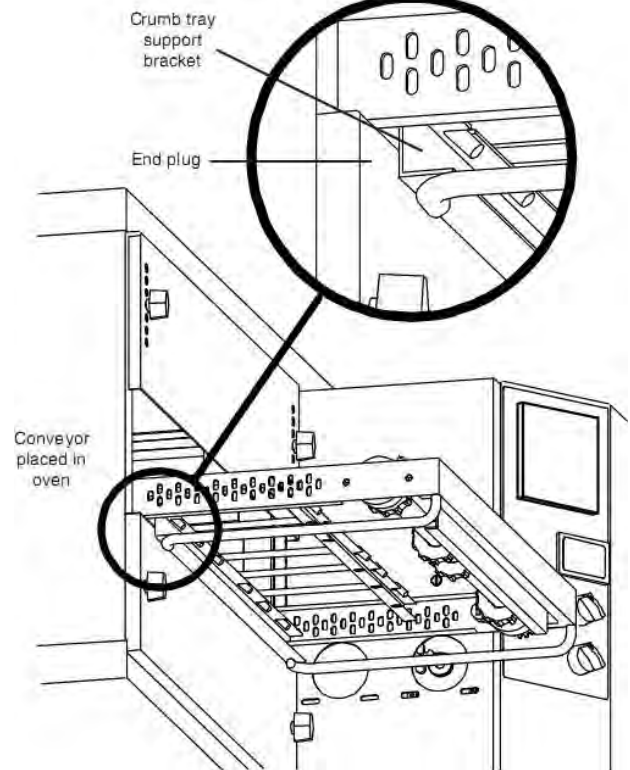
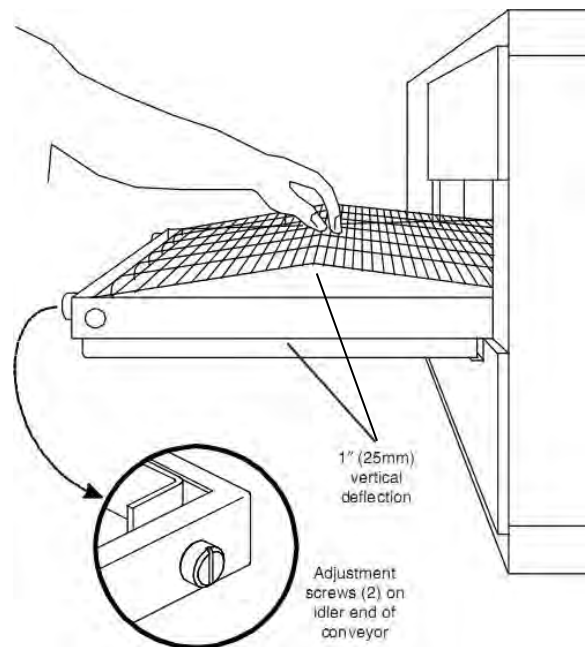

Figure 2-14. Conveyor Belt Tension



5. If it is necessary to add or remove conveyor links to achieve the correct tension, OR if it is necessary to reverse the conveyor belt for correct orientation, the belt will need to be removed from the conveyor frame. If this is necessary, perform the following procedure:

- Remove the conveyor assembly from the oven and place it flat on the floor.
- Remove the master links using long-nose pliers. Then, roll up the belt along the length of the conveyor frame.
- Add or remove belt links as necessary to achieve the correct belt tension.
- Replace the belt on the conveyor frame. Check that the conveyor belt links are oriented as shown in Figure 2-15, and that the smooth side of the conveyor belt faces UP.
- Connect the inside master links. Check that the links are oriented as shown in Figure 2-15.
- Connect the outside master links. Note that the outside master links each have an open hook on one side. This hook aligns with the hooks along the sides of the other conveyor links. See Figure 2-15.
- Replace the conveyor into the oven.

Figure 2-15. Conveyor and Master Link orientation

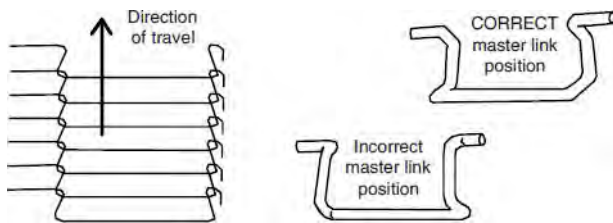

E. Final Assembly

1. Install the crumb trays underneath the conveyor as shown in Figure 2-16.

Figure 2-16. Crumb Trays

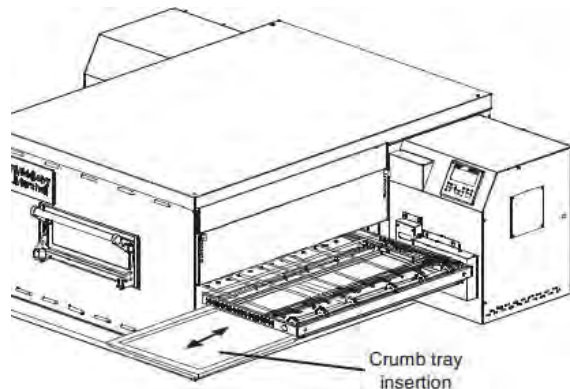

CONVEYOR BELT REVERSAL

Conveyor belt reversal consists of two steps:

1. Resetting the conveyor travel direction dip-switch labeled CW-CCW on the conveyor speed-control board.
2. Relocating the photo-cell motion-sensor detector to the new entrance side of the oven.

CAUTION:

Shock hazard in compartments electrical filters are electrically alive.



SWITCHING PHOTO-CELL MOTION-SENSOR

CAUTION:

Disconnect power before switching Photo Eye.



Remove the three screws securing the access door to the unit. Open the access door and disconnect the connector fitting to the photo eye assembly. Remove the two screws securing the photo eye assembly to the control box. Remove the four nuts securing the photo eye to the housing. Rotate the photo eye 180 degrees and affix the photo eye with the four nuts. On the opposite control box, remove the two screws holding the cover where the photo eye assembly will be positioned. Secure the photo eye assembly in position with the two screws. Place the photo eye cover on the opposite control box, where the photo eye assembly was removed, and secure the two screws. Secure the access door with the three screws. Remove the three screws securing the access door on the opposite side. Open the access door, where the photo eye is now positioned, and connect the photo eye connector fitting. Secure the access door with the three screws. Apply power to the unit. Adjust the photo eye height by loosening the two screws securing the photo eye assembly and sliding the photo eye assembly either up or down, such that the beam is approximately 1/4 inch above the belt.

Note: This procedure is MUCH easier in reduced light.

RESETTING CONVEYOR DIRECTION

Locate Conveyor Speed-Control Board inside the right control box, Identify the four dip-switches. Direction is changed by CW-CCW dip-switch adjustment on the speed control board with no wiring changes necessary.

Replace all covers.

VI. ELECTRICAL SUPPLY

CAUTION: Authorized Installation Personnel normally accomplish the connections for the ventilation system, electric supply, and gas supply, as arranged by the customer. Following these connections, the Factory-Authorized Installer can perform the initial startup of the oven.



NOTE: The electric supply installation must satisfy the requirements of the appropriate statutory authority such as the National Electrical Code, CSA C22.2; the Australian Code AG601; or other applicable regulations.

NOTE: The electric supply connection must meet all national and local electrical code requirements.

Figure 2-17. Utility Connections Locations for Electrically Heated Oven

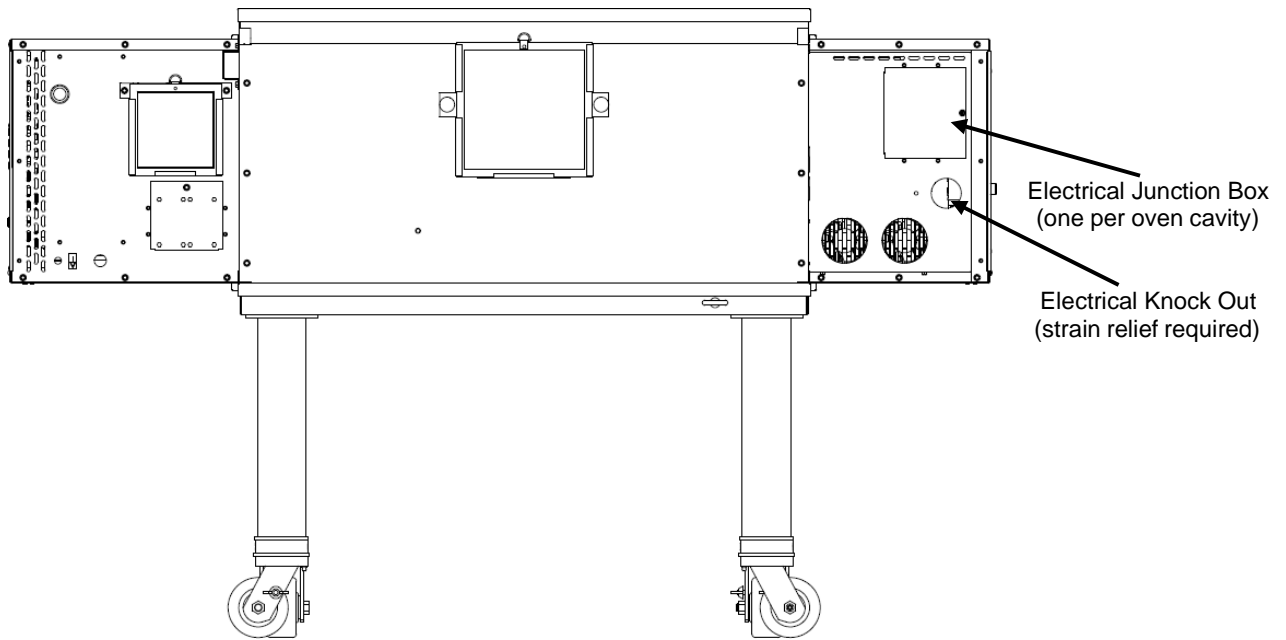

Check the oven serial plate before making any electric supply connections. Electric supply connections must agree with data on the oven serial plate. The location of the serial plate is shown in Figure 1-1 (in Section 1, [Description](#)).

A fused disconnect switch or a main circuit breaker (customer furnished) **MUST** be installed in the electric supply line for each oven cavity. It is recommended that the switch/circuit breaker have Lockout/Tagout capability.

The supply conductors must be of the size and material (copper) recommended. Refer to the wiring diagram inside the machinery compartment of the oven. Electrical specifications are also listed on the oven's serial plate and in Table 1-3, [Electrical Specifications](#) (in Section 1, [Description](#)).

The oven requires a ground connection to the oven ground screw. For gas ovens, the screw is located in the electrical junction box (see Figure 2-17). If necessary, have the electrician supply the ground wire. Do NOT use the wiring conduit or other piping for ground connections.

Incoming electrical power lines are fed through the strain-relief fitting, shown in Figure 2-17. The electrical supply connections are made inside the electrical junction box. The power lines then connect to the oven circuits through safety switches located inside the machinery compartment and each blower motor compartment. These switches interrupt electrical power to the oven when the Machinery Compartment Access Panel is opened, OR when the rear panel is removed.

Connection

Refer to the wiring diagram inside the machinery compartment of the oven to determine the correct connections for the electrical supply lines. Connect the supply as indicated on the wiring diagram.

CAUTION: *The terms of the oven's warranty require all start-ups, conversions and service work to be performed by a Middleby Marshall Authorized Service Company.*



VI. ELECTRIC SUPPLY FOR ELECTRICALLY HEATED OVENS (cont.)

Power requirements for electrically heated ovens are usually 208 - 240VAC, 3-phase, 4-wire (3 'hot', 1 ground), although ovens built for export can have power requirements of 380VAC and 480VAC. (These ovens have a 5-wire system.) A 2" (51mm) diameter cutout/hole in the back of the machinery compartment provides access for the electrical supply connections. Using flexible cable(s) for the electrical power supply conductors requires a 2 (51mm) strain-relief fitting (not furnished) to enable safe access to the terminal block from which oven power is distributed.

The supply conductors must be of the size and material (copper) recommended to provide the current required; (refer to the data plate for the ampere specifications). The electric current rating for each conductor supplying a PS640E-Series Oven must comply to local and national codes.

Typical specifications for each PS638E-Series Oven are 208V or 240V, 3-phase, 4-wire, 60-ampere, 34.4kW. A PS638E Series Double Oven (Figure 1-2) installation would require two 60-ampere service connections, one for each oven; the 34.4kW power consumption also doubles for such an installation to 68.8kW.

The 208V or 240VAC electrically heated oven uses two legs of the supplied power to provide 208V or 240VAC power for the oven control circuitry.

ELECTRIC SUPPLY TO BE PROVIDED BY CUSTOMER

WARNING
DO NOT USE CONDUIT FOR GROUND CONNECTION.

CAUTION
IT IS RECOMMENDED THAT THE OVEN BE PLACED UNDER A VENTILATION HOOD FOR ADEQUATE AIR SUPPLY AND VENTILATION.

ELECTRIC SUPPLY TO BE PROVIDED BY CUSTOMER

CIRCUIT BREAKER

Separate circuit breaker with lockout/tagout electrical shutoff for each oven. Wire each oven separately. 100 Amp circuit breaker for 208-240V, or 50 Amp circuit breaker for 380-480V.

ELECTRICAL SPECIFICATIONS

DOMESTIC: 208V main blower motors and elements, 3 Phase, 63 Amp draw, 50/60 Hz, 208-240V control circuit, 3 pole, 4 wire system per oven (3 hot, 1 ground).
Do NOT use conduit for ground.

-or-

DOMESTIC: 240V main blower motors and elements, 3 Phase, 54 Amp draw, 50/60 Hz, 208-240V control circuit, 3 pole, 4 wire system per oven (3 hot, 1 ground).
Do NOT use conduit for ground.

-or-

EXPORT: 22kW 380V elements, 3 Phase, 39 Amp draw, 50/60 Hz, 208-240V control circuit and main blower motor, 4 pole, 5 wire system per oven (3 hot, 1 neutral, 1 ground).
Do NOT use conduit for ground.

-or-

EXPORT: 18kW 380V elements, 3 Phase, 37.4 Amp draw, 50/60 Hz, 208-240V control circuit and main blower motor, 4 pole, 5 wire system per oven (3 hot, 1 neutral, 1 ground).
Do NOT use conduit for ground.

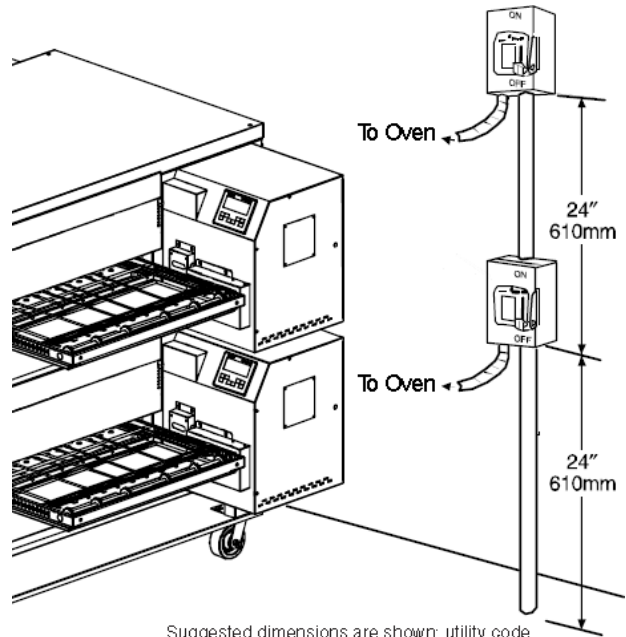

Suggested dimensions are shown; utility code requirements supersede any factors shown.

Typical PS638-Series Oven Installation

ELECTRICAL RATING

22.0 kW/hr.

SUPPLY WIRE

Supply wire size must be in accordance with the National Electrical Code (current edition) and must be in compliance with local codes.

NOTE: The electrical terminal connection marked "MP" located inside the control compartment is designated for the blue (neutral) wire to the oven. See the electrical wiring diagram/schematics in Section 6 of this manual.

SUGGESTED

If space permits, service should be located near the control console end of the oven(s) to allow convenient access to safety switches.

Figure 2-17. Utility Connection Locations for Gas Ovens

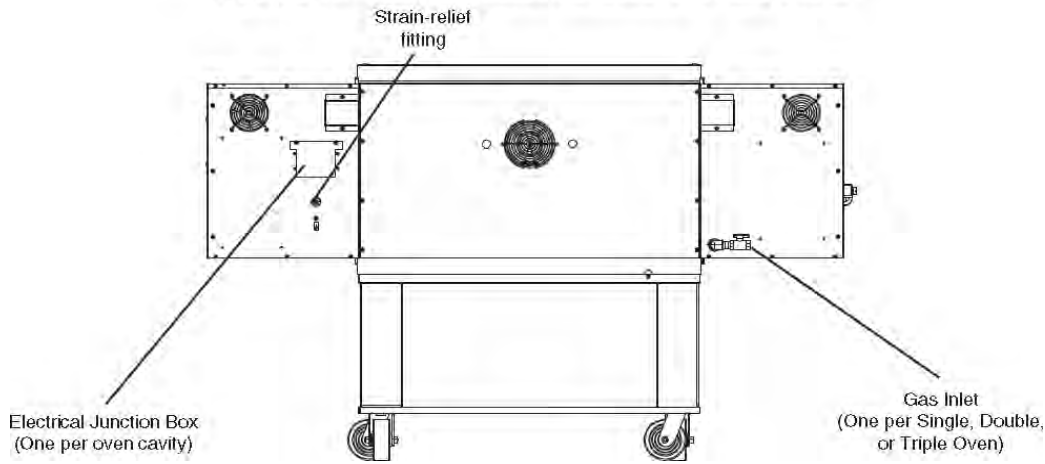

VII. GAS SUPPLY

CAUTION: DURING PRESSURE TESTING NOTE ALL OF THE FOLLOWING:



1. The oven and its individual shutoff valve must be disconnected from the gas supply piping system during any pressure testing of that system at test pressure in excess of ½ psi (3.45 kPa).
2. The oven must be isolated from the gas supply piping system by closing its individual manual shutoff during any pressure testing of the gas supply piping system at test pressure equal to or less than ½ psi (3.45 kPa).
3. If incoming pressure is over 14" W.C. (35 mbar), a separate regulator **MUST** be installed in the line **BEFORE** the individual shutoff valve for the oven.

CAUTION: To prevent damage to the control valve regulator during initial turn-on of gas, it is very important to open the manual shutoff valve very slowly.



After the initial gas turn-on, the manual shutoff valve must remain open except during pressure testing as outlined in the above steps or when necessary during service maintenance.

A. Gas Utility Rough-In Recommendations

The following system specifications are **STRONGLY RECOMMENDED**. Deviating from these recommendations may affect the baking performance of the oven.

Gas Meter

- One or two cavities: 425 CFH meter
- Three oven cavities: 630 CFH meter

Gas Line

- **DEDICATED GAS LINE** from the gas meter to the oven
- 1-½" (38.1mm) pipe for Natural gas
- 1-½" (38.1mm) pipe for Propane gas
- Maximum length: 200' (61m). Each 90° elbow equals seven additional feet (2.13m) of pipe.

B. Connection

Check the oven's gas supply requirements before making the gas utility connections. Gas supply requirements are listed on the oven's serial plate and in Table 1-4. Gas Orifice and Pressure Specifications (in Section 1, Description).

Check the serial plate to determine the type of gas (Propane or Natural) to be used with the oven.

Refer to the instructions in the gas hose package (included in the Installation Kit) before connecting the gas line. One gas line connection method is shown in Figure 2-18; however, compliance with the applicable standards and regulations is mandatory.

Inlet and regulated gas pressure readings can be taken using a digital tube manometer at the tap location shown in Figure 2-19. Figure 2-19 shows the burner assembly and Figure 2-21 shows the gas valve.

NOTE: The installation must conform with local codes or in the absence of local codes, to the National Fuel Gas Code, ANSI Z223.1-latest edition.

Certain safety code requirements exist for the installation of gas ovens; refer to the beginning of Section 2 for a list of the installation standards. In addition, because the oven is equipped with casters, the gas line connection shall be made with a connector that complies with the Standard for Connectors for Movable Gas Appliances, ANSI Z21.69/CSA 6.16 (in U.S.A.), as well as a quick-disconnect device that complies with the Standard for Quick-Disconnect Devices for Use With Gas Fuel, ANSI Z21.41/CSA 6.9 (in U.S.A.).

C. Gas Conversion

Where permitted by local and national codes, it is possible to convert ovens from natural gas to propane or from propane to natural gas. Use the appropriate Middleby Gas Conversion Kit for the specific oven model.

CAUTION: The terms of the oven's warranty require all startups, conversions and service work to be performed by a Middleby Authorized Service Agent.



D. PS638G Propane/ULPG Conversion

Three items must be changed to change the oven to operate on ULPG (See Addendum for ULPG Conversion Kit # 74072)

1. Replace main orifices.
2. Replace the By-Pass orifice
3. Adjust main gas regulator.

Disconnect the manifold union closest to the main burner, and remove the manifold assembly (four screws). Slide out the manifold assembly (leaving the ignition and sense wires connected). Replace the main orifices on the manifold assemblies with the ULPG orifices, and replace the manifold assembly. Reconnect the union.

Loosen the By-Pass tube fitting to replace the By-Pass orifice, tighten the tube fitting with the ULPG orifice inside accordingly.

Remove the seal cap on the regulator and rotate the adjustment screw in the clockwise direction to increase the regulated pressure to 6" w.c. (1.49kPa) at the manifold.

E. Adjusting the Maximum Pressure Setting

If maximum rate pressure needs adjustment, follow instruction in section I. PS638G GAS SPECIFICATIONS

Figure 2-18. Flexible Gas Hose Installation

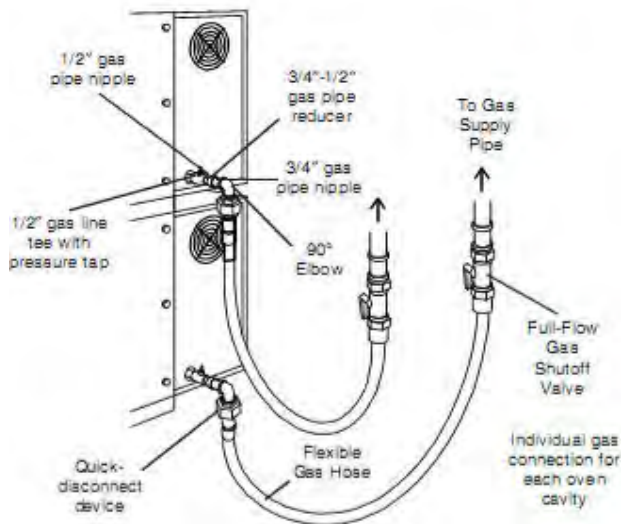

Figure 2-19. Gas Burner Assembly

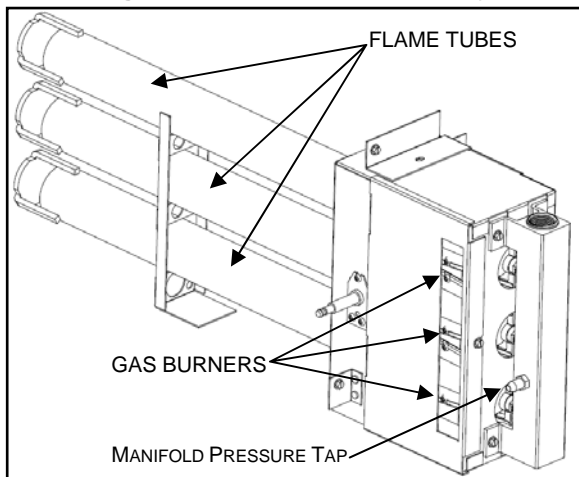
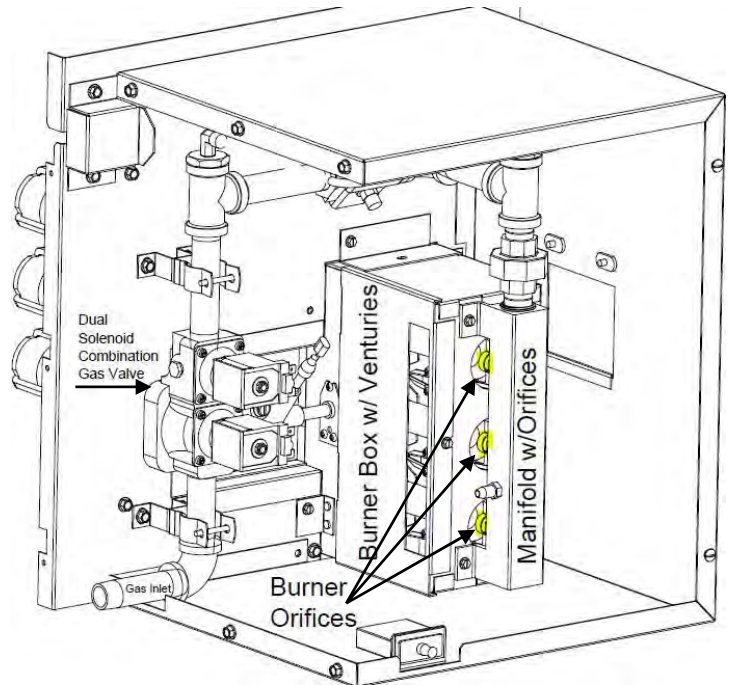

Figure 2-20. Burner Components



F. Checkout

After any adjustment, set appliance in operation and observe through a component cycle to ensure that burner system components function correctly.

NOTE: The installer **MUST** verify oven operation prior to putting oven into service.

G. Maintenance

It is recommended to check yearly the minimum and the maximum setting and readjust them if necessary.

H. Gas Train with Orificed By-Pass

For the Gas Trains that contain the Maxitrol Modulation Valve and an mushroom spud orifice inside the by-pass tube, no adjustments are required for the minimum pressure setting.

Figure 2-21. By-Pass Tube and Orifice Location

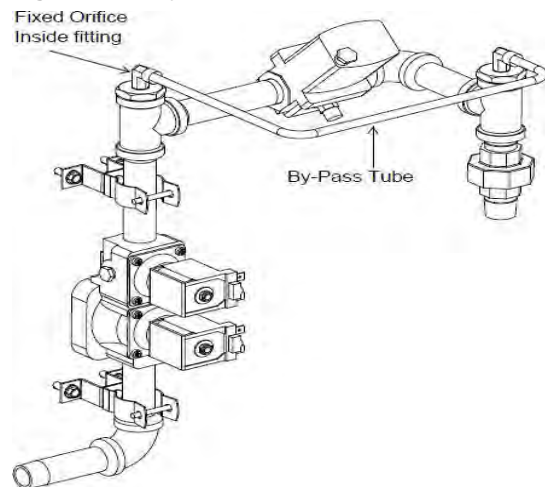

I. PS638G GAS SPECIFICATIONS

Natural Gas

Maximum Gas Input Rate: 89,000 BTU/Hr (26.1 kW)
Incoming Gas Pressure Required: 6 - 8 inches w.c.
(1.5 KPa – 2.0 KPa) (14.9 – 19.9 mbar)
Burner Gas Manifold Pressure: 3.5 inches water column
(0.87 KPa) (8.7 mbar)
Main Injector Size (3X): #39 drill (0.0995") (2.527mm) /
Marked #39 on injector
Bypass Injector Diameter: #49 drill (0.073") (1.854mm)

Propane Gas

Maximum Gas Input Rate: 89,000 BTU/Hr (26.1 kW)
Incoming Gas Pressure Required: 11 - 14 inches w.c.
(2.7KPa – 3.5KPa) (27.4 – 34.9 mbar)
Burner Gas Manifold Pressure: 6.0 inches water column
(1.5 KPa) (14.9 mbar)
Main Injector Size (3X): 1.75mm (0.0689") / Marked
1.75 on injector
Bypass Injector Diameter: #55 drill (0.052") (1.321mm)

NATURAL GAS PRESSURE ADJUSTMENT [Factory Pre-Set]



1. Turn the gas supply to the oven OFF. Open the tap screw in the MANIFOLD PRESSURE TAP fitting one full turn. Connect a silicone tube between the manifold pressure tap and a digital manometer. ZERO the digital manometer before performing the next step.



Regulator Cap

2. Locate the cap covering the pressure regulator adjusting screw on the combination gas control valve. Remove the cap to expose the pressure adjustment screw. Turn the gas to the oven on and start the oven.
3. Set the oven temperature to 550°F (288°C) and allow the oven to heat to 300°F (149°C). With the HEAT percentage on the user interface showing 100%, check the gas manifold pressure. For natural gas the pressure should read 3.5 inch water column (0.95 KPa, 8.7 mbar). *To make any adjustments use either a 5/16" wide (7.9mm) flat blade screwdriver or a T40 Torx bit is required.*
4. If the measured gas pressure is higher than the required gas pressure setting, then turn the pressure adjustment screw counter-clockwise to decrease the gas pressure to the desired setting.
5. If the measured gas pressure is lower than the required gas pressure setting, then turn the gas pressure adjustment screw clockwise to increase the gas pressure to the desired setting.
6. Replace the cap removed in step 2 back onto the combination gas control valve and tighten.
7. Turn the oven off. Turn off the gas supply to the oven. Remove the silicone tube from the manifold pressure tap. Turn the screw in the manifold pressure tap to the closed position. Make sure the screw is tightened securely. **DO NOT OVER TIGHTEN.**
8. Turn on the gas supply to the oven.
9. The oven is now ready for operation.

GAS CONVERSION

Where permitted by local and national codes, it is possible to convert ovens from natural gas to propane/ULPG or from ULPG to natural gas. Use the appropriate Middleby Gas Conversion Kit for the specific oven model.

CAUTION: *The terms of the oven's warranty require all start-ups, conversions and service work to be performed by a Middleby Authorized Service Agent.*

ULPG Orifice Conversion Procedure

1. Disconnect the gas supply to the oven.
2. Disconnect the manifold union closest to the gas burner manifold.
3. Remove the four screws securing the burner manifold assembly to the burner box (Retain these screws they will be needed for reassembly).
4. Remove the burner manifold from the burner box.
5. Remove the existing main burner orifices and replace them with the main orifices supplied in the Middleby propane/ULPG kit. (1.75 mm)
6. Replace the burner manifold into the burner box and secure the burner manifold to the burner box with the four screws removed in step 3 above.
7. Tighten the union connection that was loosened in step 2 above.
(For steps 8-11, See page 20, Figure 2-21: ByPass Tube and Orifice Location drawing)
8. Remove the two compression nuts on the ¼" (6.35mm) diameter aluminum tubing. Inside of the ¼" (6.35mm) diameter tubing (Located in the tee above the union) will be a small orifice.
9. Remove the by-pass orifice from the ¼" (6.35mm) diameter tube.
10. Insert the by-pass orifice from the Middleby propane conversion kit (#55 drill, 0.052" diameter, 1.321 mm) into the same position in the ¼" (6.35mm) diameter tube where the previous orifice was removed.
11. Reconnect the ¼" (6.35mm) tubing with the compression nuts that were removed in step 8 above.

ULPG Pressure Adjustment

1. Locate the cap covering the pressure regulator adjusting screw on the combination gas control valve.
2. Remove the cap to expose the pressure adjustment screw.

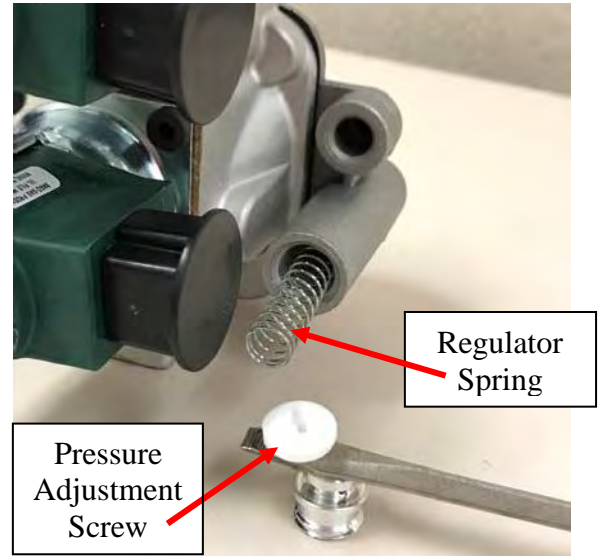

3. Using a 5/16" wide (7.9mm) flat blade screwdriver (or a T40 Torx if available) remove the pressure adjuster screw by turning counter-clockwise.
4. If the measured gas pressure is higher than the required gas pressure setting, then turn the pressure adjustment screw counter-clockwise to decrease the gas pressure to the desired setting.
5. If the measured gas pressure is lower than the required gas pressure setting, then turn the gas pressure adjustment screw clockwise to increase the gas pressure to the desired setting.
6. Set the gas manifold pressure to 6 inches water column (1.5 kPa, 14.9 mbar) for Propane/ULPG.
7. Replace the cap removed in step 2 back onto the combination gas control valve and tighten.
8. Turn the oven off. Turn off the gas supply to the oven. Remove the silicone tube from the manifold pressure tap. Turn the screw in the manifold pressure tap to the closed position. Make sure the screw is tightened securely. **DO NOT OVER TIGHTEN.**
9. Turn on the gas supply to the oven.
10. The oven is now ready for operation.

SECTION 3 – OPERATION

WARNING

DO NOT SPRAY AEROSOLS IN THE VICINITY OF THIS APPLIANCE WHILE IT IS IN OPERATION

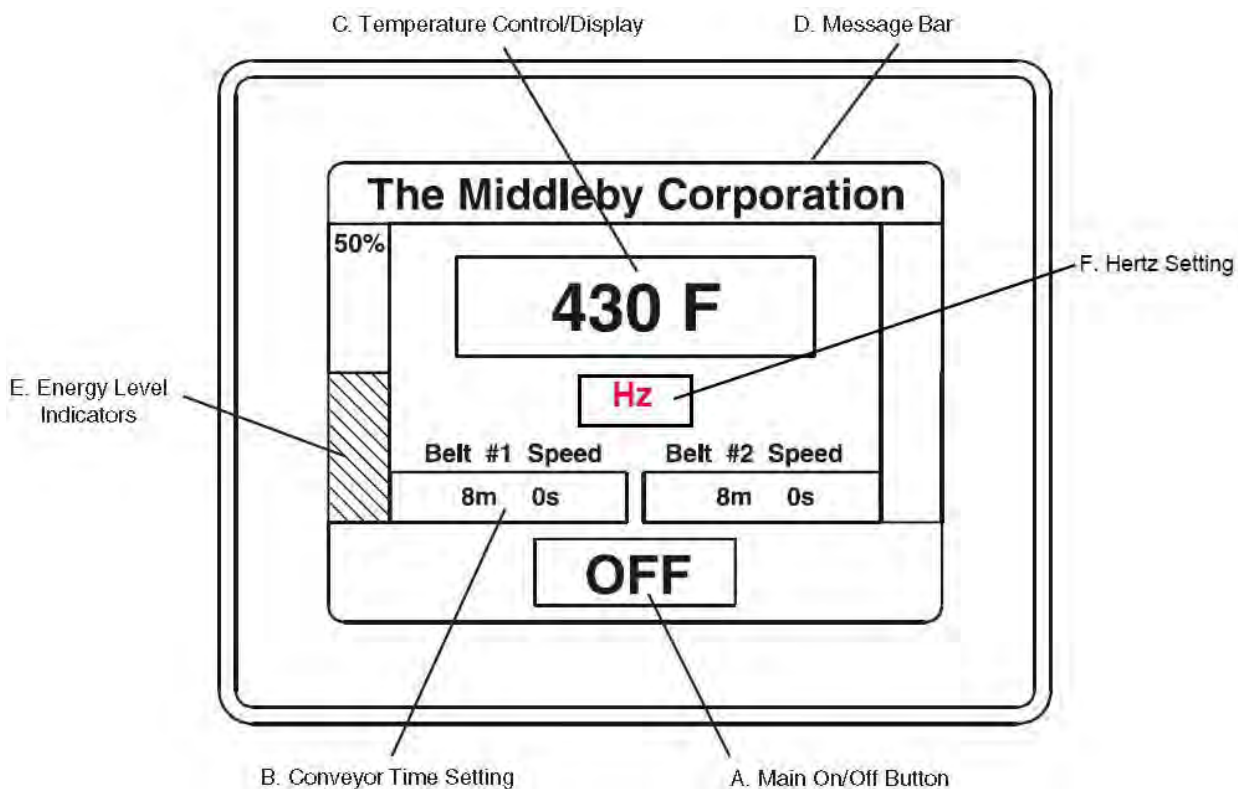

I. DESCRIPTION AND LOCATION OF HIGH RESOLUTION SCREEN CONTROLS

- A. Main ON/OFF BUTTON:** Turns on or off oven controls.
If oven is above 200°F, blowers will remain on until oven cools down.
- B. Conveyor Time Setting:** Displays the conveyor bake time.
Dual belt ovens have two displays.
Press Hz button to adjust bake time.
- C. Temperature Setting:** Displays oven temperature set point
Press Hz button to adjust temperature set point
- D. Message Bar:** Displays various messages during operation.
Error messages and warning messages may also be displayed here.
- E. Energy Level Indicators** Displays real time energy usage of the oven.
- F. Hertz Setting** Displays the variable frequency drive baking hertz inverter setting.
Press Hz button to adjust the Hz setting or blower rpm.
Pressing the Hz button also allows for belt time and temperature adjustment.

II. NORMAL DAILY STEP-BY-STEP OPERATION

A. DAILY START-UP PROCEDURE

1. Check that the circuit breaker/fused disconnect is in the ON position.
2. Check that the optional window is closed.
3. Turn the two-position rotary-switch to ON.
4. Adjust the Bake-Time Belt-Speed accordingly.
5. Adjust the Temperature Set Point accordingly.
6. Turn the OFF button to ON if necessary.
7. Allow for *The Ignition Sequence of Operation*.

B. DAILY SHUT-DOWN PROCEDURE

1. Make certain no product remains on conveyor nor are still inside the oven.
2. Press the ON square to turn off the oven.
3. Turn the two-position rotary-switch to OFF.
4. Only After the oven has cooled down and the blowers have turned off may the circuit breaker or main disconnect be turned off.

HIGH RESOLUTION TOUCH SCREEN CONTROLS – QUICK REFERENCE GUIDE

Main ON/OFF Button: Turns on or off oven controls. If oven is above 200°F, blowers will remain on until oven cools down.

Conveyor Time Setting: Displays the conveyor bake time. Dual belt ovens have two displays. Press Hz button to adjust bake time.

Temperature Setting: Displays oven temperature set point. Press Hz button to adjust temperature set point

Message Bar: Displays various messages during operation. Error messages and warning messages may also be displayed here.

Energy Level Indicators: Displays real time energy usage of the oven.

Hertz Setting: Displays the variable frequency drive baking hertz inverter setting. Press Hz button to adjust the Hz setting or blower rpm. Pressing the Hz button also allows for belt time and temperature adjustment.

C. GAS OVEN INITIAL IGNITION SEQUENCE OF OPERATION

The PS638G performs the following sequence of operation when first turned on:

- A. Turns main blower on for 15 seconds. If the oven uses a pressure switch, it would check the opening/closing of the pressure switch. If the oven uses a rotation sensor, then it would check the sensor signal to make sure fans are running.
 - B. Turns main blower on at low speed and the burners on at 100% full open valve (the red energy indicator level bar will be at the maximum height). The Blower & Burner System will remain in this ignition "lighting" position for 60 seconds.
 - C. The Igniter Lights the Burner Flame.
 - D. The burner modulation valve moves to the low by-pass position for 80 seconds. This is the flame sensor-rod cleaning position = low blower rpm's -and- low flame(no red energy bar)
 - E. The Burner and Blower Systems will ramp-up to full-power, full-operation.(maximum red energy level indicator bar height)
- Lowering the oven temperature more than 30°F will turn the burner off until the actual oven temperature decreased to this new temperature set point. The burner will then relight without performing the full ignition sequence of operation cycle.
 - If the flame sense were lost, then the oven would immediately attempt to relight without any change of flame or blower (i.e. immediate sparking sequence, followed by the inter-purge sequence of 15 seconds; three spark/inter-purge cycles to re-light before ignition lock-out).
 - If the oven is turned off and then turned back on, then the full Ignition Sequence of Operation will cycle accordingly.

D. ENERGY MANAGEMENT INFORMATION

The PS638 reduces energy usage in two ways over most competitive ovens:

- Modulating Gas Control (Gas Energy Management System)
- Pulsing Solid State Relay (Electric Energy Management System)
- BAKING / IDLE Blower Speed (Energy Saving Mode)

The modulating gas valve within the oven controls pressure of the delivered gas to the burners to increase or reduce the energy input as needed to maintain temperature instead of cycling a gas valve on and off. This is a more efficient and accurate way of controlling the temperature and eliminates the losses associated with the ON/OFF HIGH/LOW cycling control.

The PS638 like other Middleby WOW ovens has an optional idle mode that places the blowers at a reduced speed during non-baking periods. Reducing the blower speed reduces the volume of air movement requiring heating and thus reduces energy usage during these non-baking times. A photo eye sensor at the entrance side of the baking chamber detects when food is placed on the belt and brings the oven up to the higher (baking) blower speed, increasing the amount of impingement convection air needed to cook products faster. When the product passes the photo eye, the controller begins a preset timed period that insures the product will pass fully through the oven before the oven returns to the IDLE mode. With this energy management scheme, the oven provides the increased convection heat transfer needed for fast baking, without the energy penalty during non-baking times. This functionality is fully automatic and requires no user interaction.

III. OTHER ADJUSTMENTS (MANAGER MODE)

A. PLC SYSTEM CONTROL AND OPERATION

When the PS638 Oven, Display, and PLC are powered up by the ON-OFF Rotary Switch, the following screen will appear:

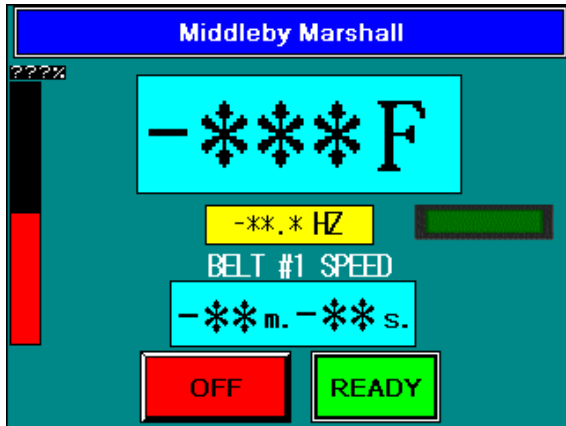

Setting Temperature, Baking Hertz, and Belt Speed

Press the yellow HZ box on the main screen to pop the following MENU SETTING:

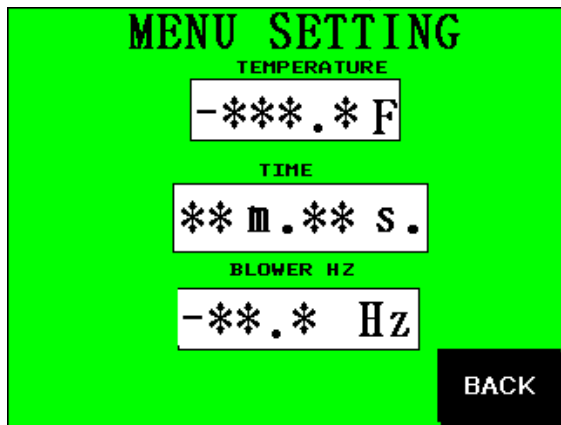

To change any set point, press on its box, which will bring up a keypad screen.

- Press the TEMPERATURE block, to change temperature, then press "ENT" button. Temperature set point is adjustable with the oven on or off.
- Press the [Bake] TIME block to enter a new bake time.
- Press the BLOWER HZ block to change the BAKING Hertz setting.

When finished making bake adjustments, press the BACK button. **WAIT** for the main screen to display **READY**. Now the oven is at the proper belt speed and temperature for baking.

Pressing on the Temp Display – brings up the set-point and actual temperature displays. There is also a button to enable/disable the optional photocell.

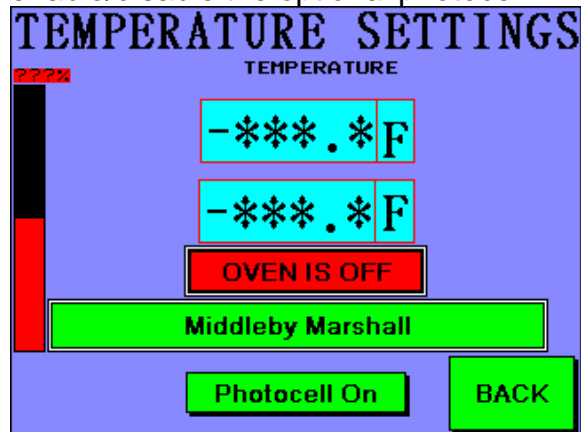

The **MONITORING SCREEN** Button activates the next menu:

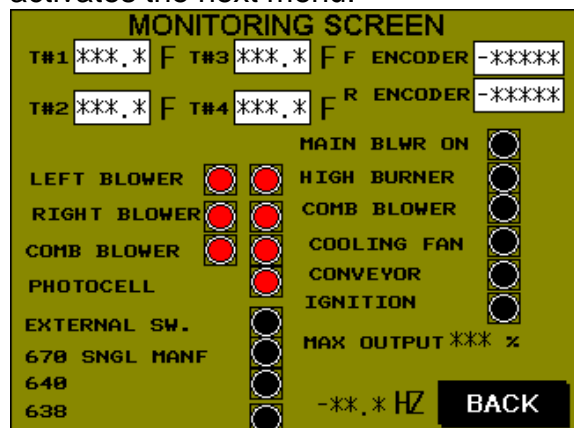

This is a monitoring screen, which not only shows you temperatures and encoder readings, but also PLC input and relay status. It also shows what type of oven the PLC is programmed for.

B. MENU SELECT

The menu select operation is similar to standard operation.

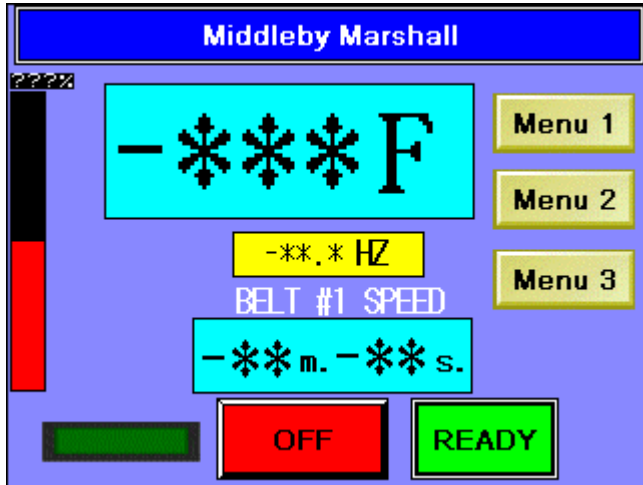

There are three menu buttons: These allow the operator to toggle between preset menus (temperature, bake time, and blower Hz). Pressing the Hz value will not bring up a setting screen, but WILL bring up a password screen.

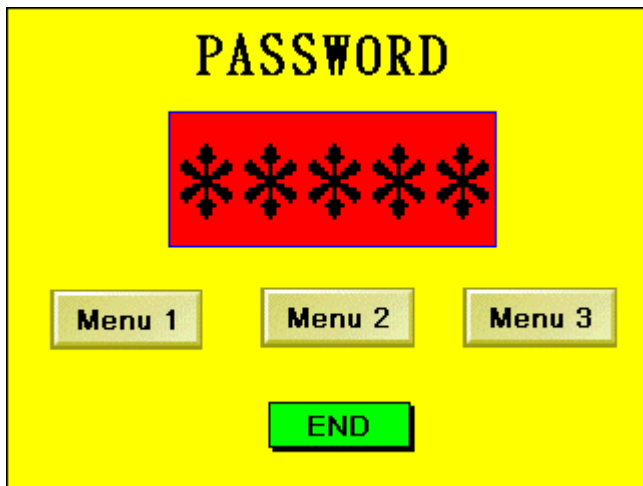

Entering the password "CHUCK" will allow each of these menus to be set the same way as the standard oven.

IV. PS638 TROUBLESHOOTING INFORMATION

A. TROUBLESHOOTING GUIDE

SYMPTOM	POSSIBLE CAUSES	SOLUTIONS
Nothing displayed on controller	<ol style="list-style-type: none"> 1. Power not connected 2. Main breaker not on 3. Control circuit breaker tripped 	<ol style="list-style-type: none"> 1. Check plug at wall 2. Check main breaker 3. Check control breaker
WOW OVEN or other screen saver image can be seen	Control is in OFF/STANDBY mode.	No problem – screen saver appears when the oven is not turned on for use. Press BACK button.
Oven not baking properly	<ol style="list-style-type: none"> 1. Settings have been changed 2. Kitchen airflow conditions affecting the bake 	<ol style="list-style-type: none"> 1. Confirm correct values and check that the oven is set properly (time and temperature) 2. Eliminate air cross-currents in area
Conveyor noticeably running at the wrong speed	Time settings have been changed	Confirm correct values and correct control settings
Conveyor not moving	<ol style="list-style-type: none"> 1. Something has jammed the conveyor 2. Circuit breaker has tripped 3. Chain has come loose from the sprocket 4. Oven is not at operating temperature 	<ol style="list-style-type: none"> 1. Turn power off. Locate and remove jam item. 2. Check conveyor for jamming and Reset the breaker (right side control door). 3. With power OFF, remove chain cover, replace chain onto sprocket and replace chain cover.
Oven not heating	<ol style="list-style-type: none"> 1. Gas not turned on to oven 2. Burner has stopped running 	<ol style="list-style-type: none"> 1. Turn on manual valve on supply to oven 2. Turn the oven off and back on again to clear the notification and relight <ul style="list-style-type: none"> • Arrange for service if the problem reoccurs
“BAKING” indication goes on and off in the control display	Oven is cycling normally. BAKING indication comes on upon triggering the photo eye.	No problem – the timed baking cycle automatically starts when product breaks the photo eye beam and stops after product leaves the baking chamber.
Oven does not enter BAKING mode when product is placed on the belt.	Photo eye not working.	Enter MONITORING SCREEN to see eye trigger (manager access). and/or turn Energy Mode to OFF. Oven will now run in BAKING mode all the time. Call service to schedule repair.
Baked product comes out underdone.	Photo eye not working. Check to see if BAKING appears on display when photo eye beam is interrupted	Enter MONITORING SCREEN (manager access) to see if eye triggers PLC. And/or turn Energy Mode to OFF. Oven will now run in BAKING mode all the time. Call service to schedule repair.

B. ALERTS, ERROR MESSAGES, & REMEDIES

MESSAGE	PROBABLE CAUSE	REMEDY
CLEAN FILTERS -or- CONTROL OVERTEMP.	Cooling Fan Filters are clogged. Cooling Fans are not working	Clean Rear Filters Call for Service to Repair.
FRONT BELT JAMMED -or- REAR BELT JAMMED	Belt was overloaded and control shut down the belt.	Remove Obstruction, reset circuit breaker(s), restart the oven.
BELT OFF OVEN NOT IN TEMP RANGE	This is normal operation until the oven reached the operating temperature range.	
MAIN BLOWER ERROR	Blower Operating Proving System is not satisfied.	Reset the oven to clear the message. If the message does not clear, call for service.
HIGH TEMP ERROR	All thermocouple probes have failed and are open.	Call service for repair.
**00FF	Communication between the display (user interface) and the I/O board has been disrupted.	Call service for repair.

NOTE: If the remedial measures above do not successfully resolve the issue, or if the issue is not listed above, then contact the Middleby Customer Care Center at 847-429-7852.

SECTION 4 - MAINTENANCE

WARNING

Before ANY cleaning or servicing of the oven, perform the following procedure:

1. Switch off the oven and allow it to cool. Do NOT service the oven while it is warm.
2. Turn off the electric supply circuit breaker(s) and disconnect the electric supply to the oven.
3. If it is necessary to move a gas oven for cleaning or servicing, disconnect the gas supply before moving the oven.

When all cleaning and servicing is complete:

1. If the oven was moved for servicing, return the oven to its original location.
2. If the restraint cable was disconnected to clean or service the oven, reconnect it at this time.
3. Reconnect the gas supply.
4. Reconnect the electrical supply.
5. Turn on the full-flow gas safety valve. Test the gas line connections for leaks using approved leak test substance or thick soap suds.
6. Turn on the electric supply circuit breaker(s).
7. Perform the normal startup procedure.

WARNING

Possibility of injury from moving parts and electrical shock exists in this oven. Switch off and lockout/tagout the electric supply BEFORE beginning to disassemble, clean, or service any oven. Never disassemble or clean an oven with the BLOWER switch or any other circuit of the oven switched on.

CAUTION

NEVER use a water hose or pressurized steam-cleaning equipment when cleaning this oven. To avoid saturating the oven insulation, DO NOT use excessive amounts of water. DO NOT use a caustic oven cleaner, which can damage the bake chamber surfaces.

NOTE

ANY replacement parts that require access to the interior of the oven may ONLY be replaced by a Middleby Marshall Authorized Service Agent. It is also strongly recommended that the 3-Month Maintenance and 6-Month Maintenance procedures in this section be performed ONLY by a Middleby Marshall Authorized Service Agent.

I. MAINTENANCE – DAILY

- A. Check that the oven is cool and the power is disconnected, as described in the warning at the beginning of this section.
- B. Clean ALL of the cooling fan grills and vent openings with a stiff nylon brush. Refer to Figure 4-1 for the location of the grills and vents
- C. Clean the outside of the oven with a soft cloth and mild detergent.
- D. Check that all cooling fans are operating properly.

CAUTION: If a cooling fan is not operating correctly, it must be replaced IMMEDIATELY. Operating the oven without adequate cooling can seriously damage the oven's internal components



- E. Clean the conveyor belts with a stiff nylon brush. This is more easily accomplished by allowing the conveyor to run while you stand at the exit end of the conveyor, and brush the crumbs off the conveyor as it moves.
- F. Remove and clean the crumb trays. If necessary, refer to Figure 2-16 (in Section 2, Installation) when replacing the crumb trays into the oven.
- G. Clean the window in place.

Figure 4-1. Cooling Vents and Grills

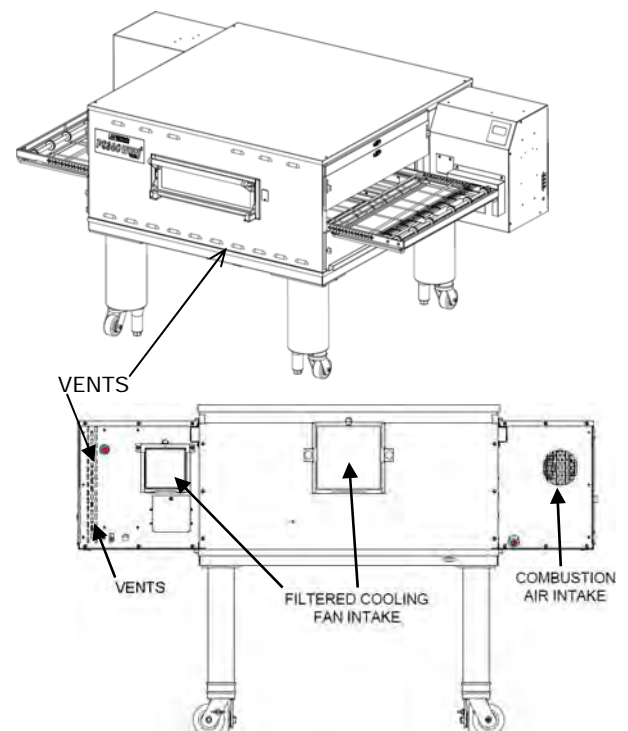

II. MAINTENANCE – MONTHLY

NOTE: When removing the conveyor, refer to Figure 2-12 (in Section 2, Installation).

- A. Check that the oven is cool and the power is disconnected as described in the warning at the beginning of this section.
- B. Remove the crumb trays from the oven.
- C. Lift the drive end of the conveyor slightly, and push it forward into the oven. This removes the tension from the drive chain. Remove the drive chain from the conveyor sprocket.
- D. Slide the conveyor out of the oven, folding at as it is removed.
- E. Remove the end plugs from the oven. The end plugs are shown in Figure 1-1 (in Section 1, Description).
- F. Slide the air fingers and blank plates out of the oven, as shown in Figure 4-2. AS EACH FINGER OR PLATE IS REMOVED, WRITE A “LOCATION CODE” ON IT WITH A MARKER to make sure it can be reinstalled correctly.

Example of markings:

Top Row →	T1	T2	T3	T4
Bottom Row →	B1	B2	B3	B4

- G. Disassemble the air fingers as shown in Figure 4-3. AS EACH FINGER IS DISASSEMBLED, WRITE THE “LOCATION CODE” FOR THE FINGER ON ALL THREE OF ITS PIECES. This will help you in correctly reassembling the air fingers.

CAUTION: *Incorrect reassembly of the air fingers will change the baking properties of the oven.*



- H. Clean the air finger components and the interior of the baking chamber using a vacuum cleaner and a damp cloth. Refer to the boxed warnings at the beginning of this Section for cleaning precautions.
- I. Reassemble the air fingers. Then replace them in the oven, using the “location codes” as a guide.
- J. Replace the end plugs on the oven.
- K. Reassemble the conveyor into the oven. If the drive sprocket was removed when installing the conveyor, replace it at this time.
- L. Reattach the drive chain.
- M. Check the tension of the conveyor belt as shown in Figure 2-14 (in Section 2, Installation). The belt should lift 1” (25.4mm) DO NOT OVERTIGHTEN THE CONVEYOR BELT. If necessary, the belt tension can be adjusted by turning the conveyor adjustment screws, located at the idler (left) end of the conveyor
- N. Replace the crumb trays.

Figure 4-2. Removing Air Fingers and Plates

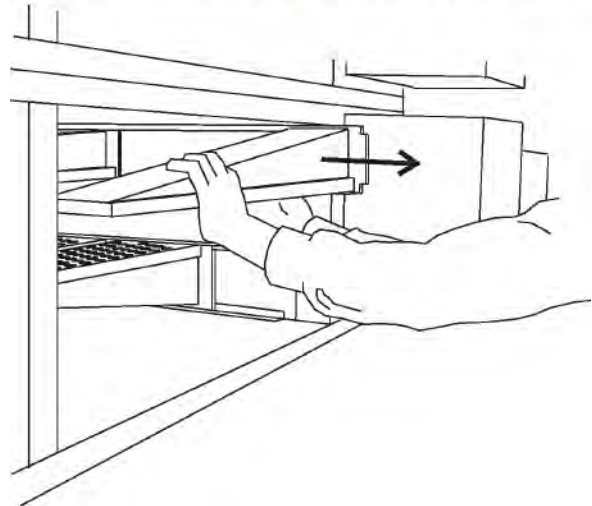
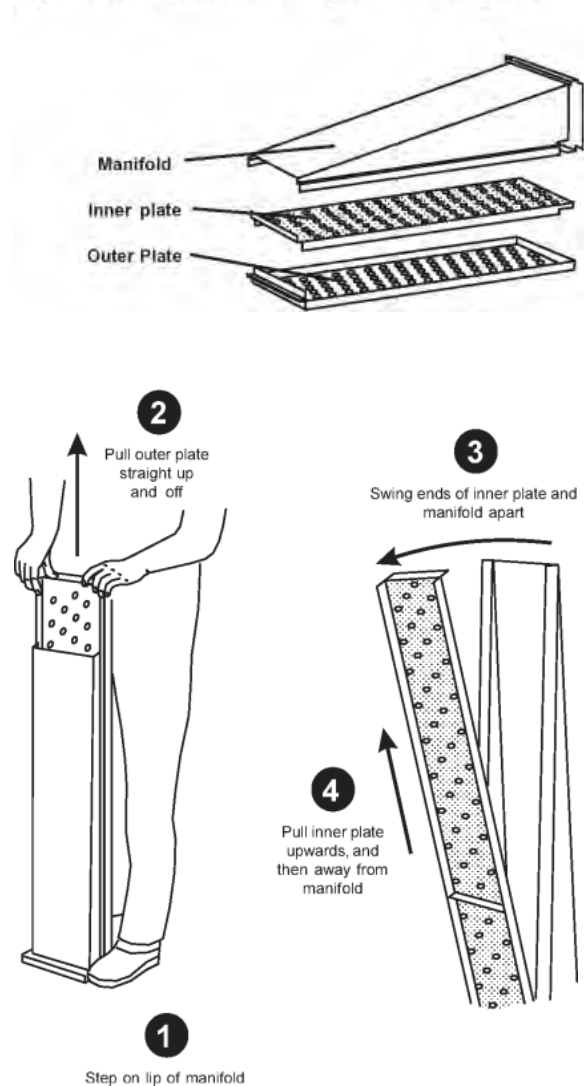

Figure 4-3. Disassembling the Air Fingers



III. MAINTENANCE – EVERY 3 MONTHS

A. Check that the oven is cool and the power is disconnected, as described in the warning at the beginning of this Section.

B. Vacuum both of the blower mounts, and their surrounding compartments, using a shop vacuum.

C. Tighten all electrical terminal screws.

D. Split Belt Disassembly and Cleaning

1. Refer to Part D, Conveyor Installation, in the Installation section of this Manual. Then, remove the following components from the oven:
 - Conveyor end stop
 - Crumb trays
 - Chain cover
 - Drive chains
 - End plugs
 - Conveyor assembly
2. Remove the master links from each conveyor belt. Then, roll the belts up along the length of the conveyor to remove them from the frame.
3. Remove the two conveyor adjustment screws from the idler end of the conveyor frame, as shown in Figure 4-4.
4. Remove the idler shaft assembly from the conveyor.
5. Pull apart the two sections of the idler shaft.
6. Clean the shafts thoroughly using a rag. Then, lubricate both the extended shaft and the interior of the hollow shaft using a light food-grade lubricant. DO NOT lubricate the shafts using WD40 or a similar product. This can cause the shafts to wear rapidly.
7. Before reassembling the shafts into the conveyor frame, check that they are oriented properly.

Figure 4-4. Disassembling the idler shaft

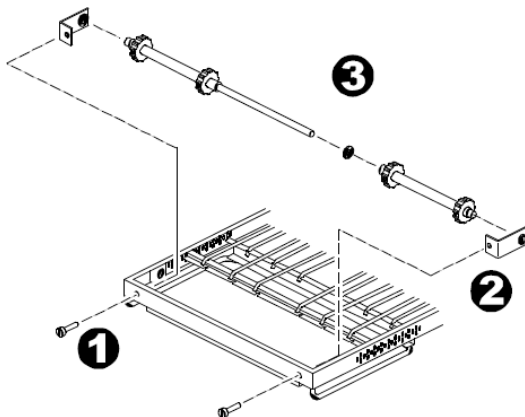

8. Reassemble the idler shaft into the conveyor. Make sure that the bronze washer is in place between the two sections of the shaft. See Figure 4-4.
9. Replace the conveyor adjustment screws as shown in Figure 4-4. To allow the conveyor belt to be reinstalled later, do not tighten the screws at this time.
10. Loosen the set screw on both of the conveyor drive sprockets. Then, remove the sprockets from the shaft.
11. Check the conveyor configuration as follows: High-speed conveyors are equipped with large flange bearings at both ends of the shaft, as shown in Figure 4-5. For these conveyors, remove the two screws that hold each bearing to the conveyor frame. With the screws removed, lift the end of the shaft at the front of the oven, and pull the entire assembly free of the conveyor frame.
12. Standard conveyors are equipped with bronze bushings mounted on spacers at both ends of the shaft, as shown in Figure 4-5. For these conveyors, remove the two screws that hold the bracket to the conveyor frame. With the screws removed, lift the end of the shaft at the front of the oven, and pull the entire assembly free of the conveyor frame. The brackets will be removed along with the drive shaft assembly.
13. Disassemble and lubricate the two sections of the drive shaft as described for the idler shaft, above.
14. Before reassembling the shafts into the conveyor frame, check that they are oriented properly.
15. Reassemble the drive shaft into the conveyor. Make sure that the bronze washer is in place between the two sections of the shaft. See Figure 4-6.
16. Replace the drive sprockets. Reassemble the belts and master links onto the conveyor.
17. Reinstall the end plugs and conveyor onto the oven. Reattach the drive chains. Replace the chain cover.
18. Check the tension of the conveyor belt as shown in Figure 2-14 (in Section 2, Installation). The belt should lift about 1" (25mm). If necessary, adjust the belt tension by turning the conveyor adjustment screws.
19. Replace all components onto the oven.

Figure 4-5. Drive shaft configurations

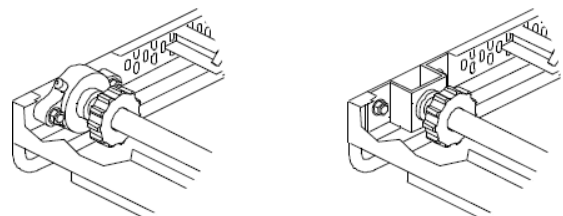
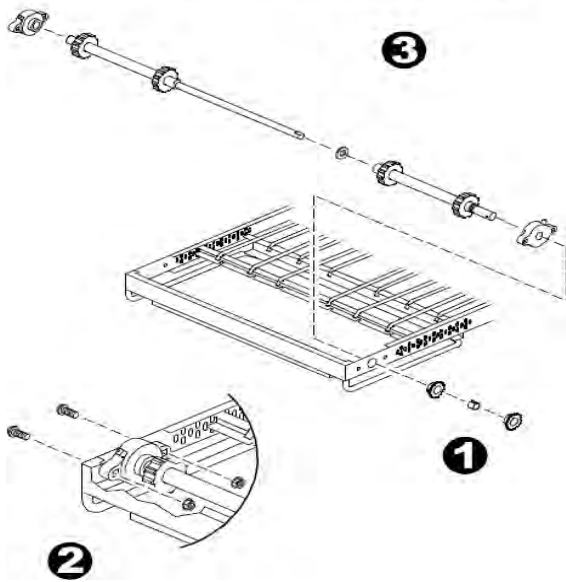

Figure 4-6. Disassembling the drive shaft



IV. MAINTENANCE - EVERY 6 MONTHS

- A. The Six-Month Maintenance should be carried out by a qualified Middleby authorized service agent or by Middleby authorized personnel.
- B. Check that the oven is cool and the power is disconnected, as described in the warning at the beginning of this Section.
- C. For gas ovens, inspect and clean the burner nozzle and the spark electrode assembly.
- D. Vacuum of the blower mounts, and their surrounding compartments, using a shop vacuum.
- E. Tighten all electrical terminal screws
- F. Check the conveyor drive shaft bushings and spacers. Replace the components if they are worn.

V. PS638E & G OVEN KEY SPARE PARTS

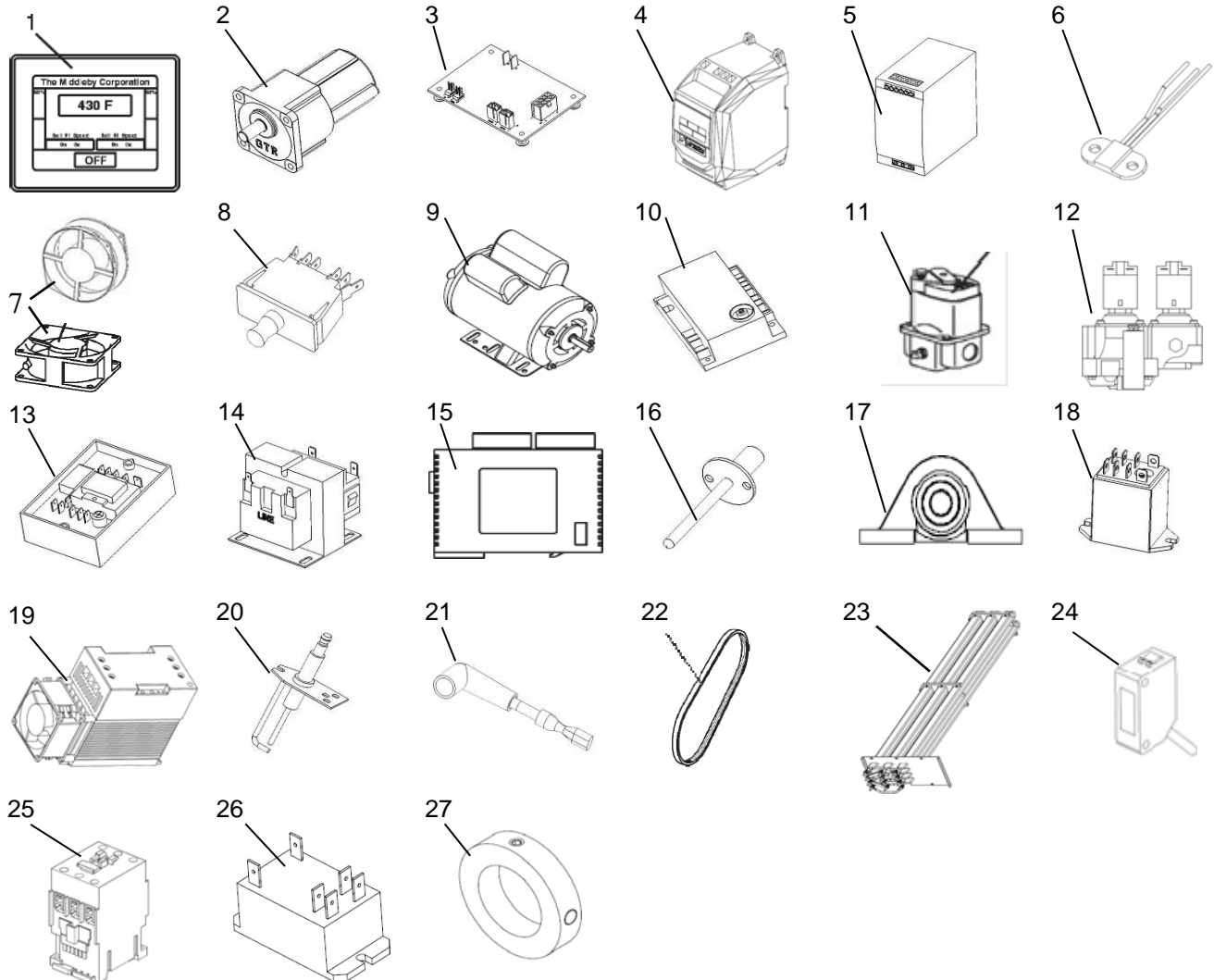

V. PS638E & G OVEN KEY SPARE PARTS

ITEM	QTY	P/N	DESCRIPTION
1	1	74453	Digital Display, Programmed
2	1	74106	Motor, Conveyor Drive (74106)
3	1	74081	Dual-Mode Conveyor Control Board
4	1	74097	VFD Inverter, 2 HP (230VAC Input)
5	1	61186	Power Supply, 24VDC, 40W
6	1	71421	Hamlin Rotation Hall Effect Sensor
7a	1	36451	Small Cooling Fan for Right Control Compartment
7b	1	97525	Large Cooling Fan for Center Rear of Oven
n/s	1	65858	Small Cooling Fan Filter (6" square)
n/s	1	73226	Large Cooling Fan Filter (9" square)
8	2	63909/63910	Door Switches, Interlock / Momentary
9	1	57288	Blower Motor, 2 HP
10	1	62285	Ignition Module (Gas Only)
11	1	59450	Maxitrol Modulating Gas Valve (Gas Only)
12	1	59465	Dual Solenoid Combination Valve (Gas Only)
13	1	33983	Hi Limit Thermostat
n/s	1	71040	High Limit Reset Button
n/s	1	71041	High Limit Light
14	1	32108	Transformer, 240 primary / 24 secondary
15a	1	67052	PLC
15b	1	58668	Thermocouple Module
15c	1	73903	Dual Output Module
16	1	33984	Thermocouple (3 per oven)
17	1	64106	Bearing, Dodge 5/8
18	1	71771	Relay, DPDT 24VDC Coil
19a	2	76289	208/240V SS Power Controllers
19b	2	76289	380/416V SS Power Controllers,
20	1	71037	Single Rod Igniter
21	1	62282	Ignition Cable
n/s	2	71815	Blower Shaft
22	1	50517	Serpentine Blower Belt
23a	1	60750	Heater, 27kW, 208VAC Specific
23b	1	74125	Heater, 27kW, 240VAC Specific
23c	1	68661	Heater, 18kW, 380VAC Specific
23c	1	73656	Heater, 27kW, 380VAC Specific
24	1	77715	Photo Eye (optional)
n/s	1	74316	Photo Eye Lens (optional)
25	1	60452	Contactora (Electric Only)
26	1	50794	Relay, 240VAC Coil
27	1	74729	Magnetic Ring
n/s	3	72737	In-Shot Burner (Gas Only)

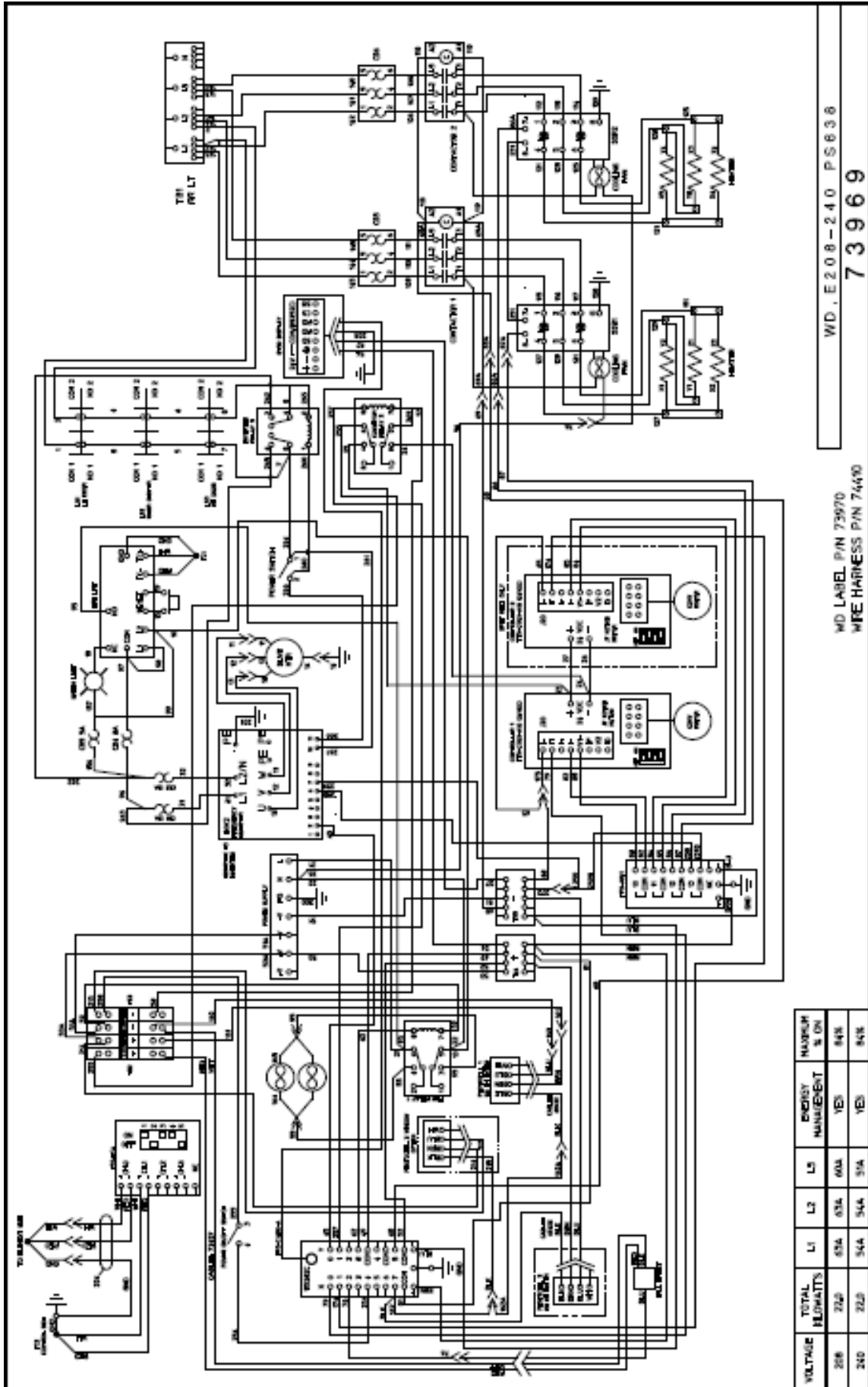

WD, E 208-240 P S 636

73969

WD LABEL P/N 73970
WIRE HARNESS P/N 74490

VOLTAGE	TOTAL FLOWMETERS	L1	L2	L3	ENERGY MANAGEMENT	HAZARD % ON
208	224	61A	61A	60A	YES	94%
240	225	54A	54A	54A	YES	94%

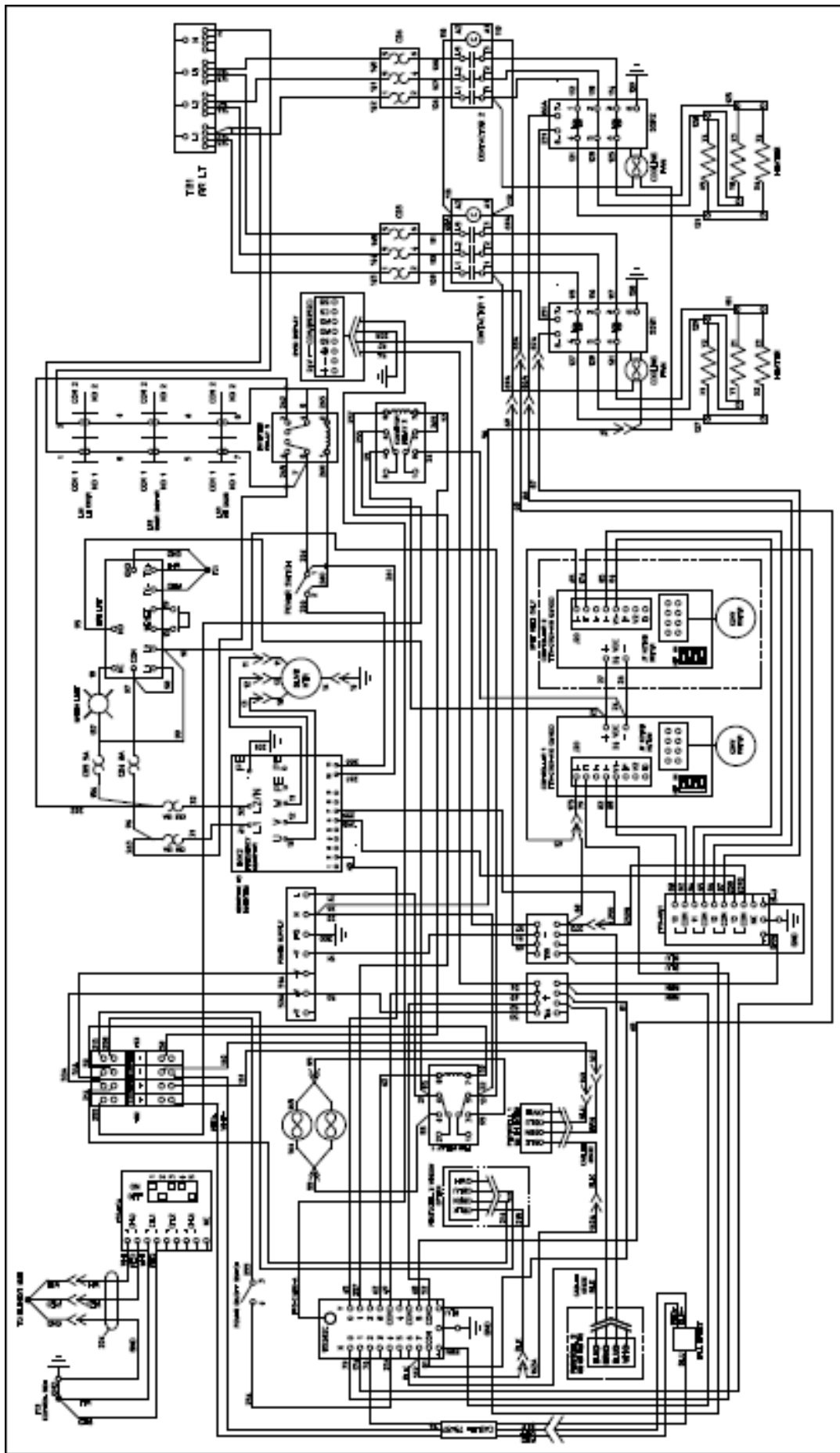

VOLTAGE	TOTAL RELWATTS	L1	L2	L3	N	ENERGY MANAGEMENT	HARNESS % ON
380	2025	384	384	384	67	YES	64%
380	2025	384	384	384	67	YES	75%

WD LABEL PIN 75071
WPC HARNESS PIN 75516

WD.E380 AC 3PH PS638

73968

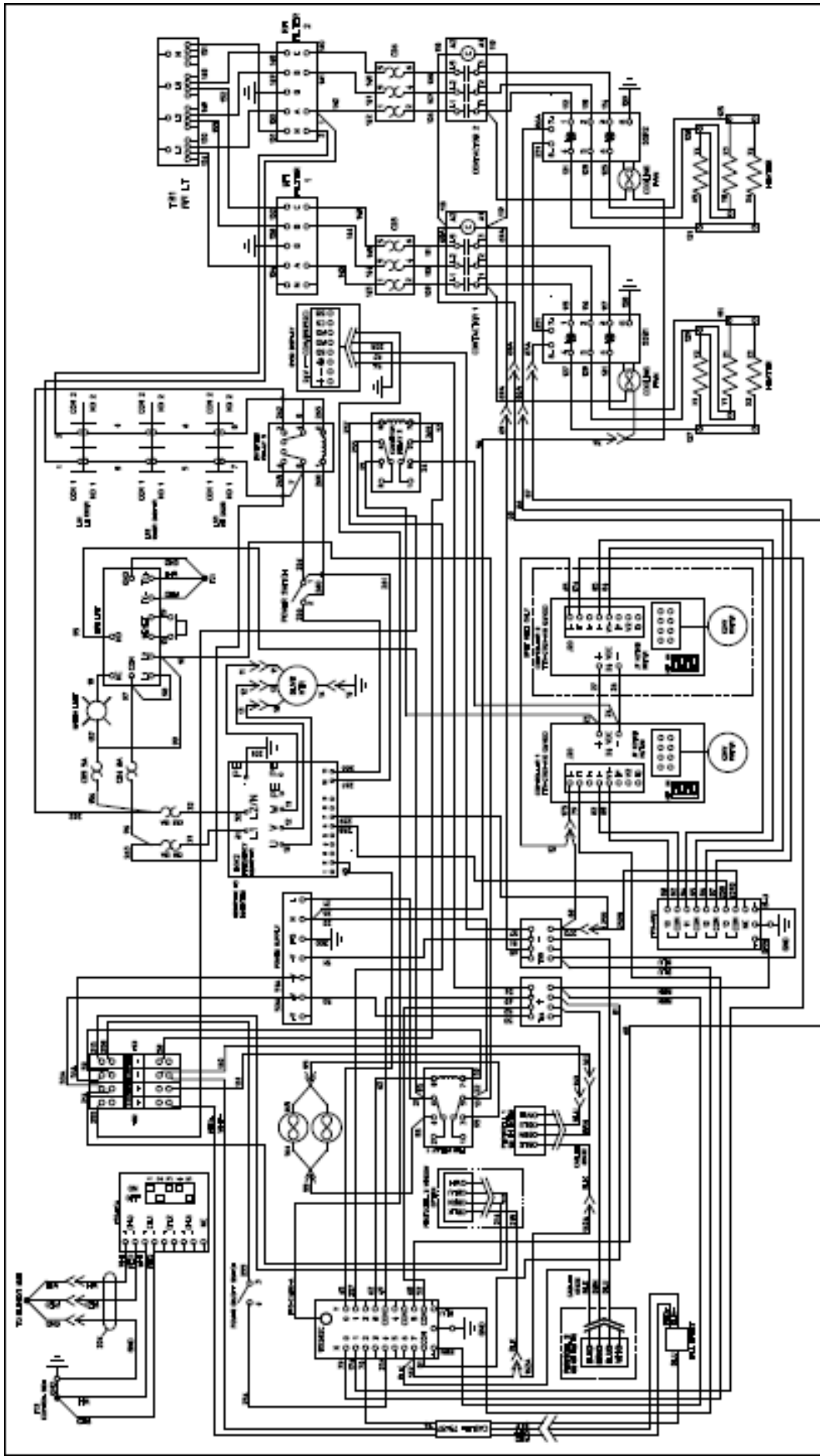

WD_E380 AC 3PH CE PS838

73773

MD LABEL PIN 75029
NRE HARNESS PIN 74510 & 74511

VOLTAGE	TOTAL WATTS	L1	L2	L3	N	ENERGY MANAGEMENT	HARNESS S. ON
360	220	30A	35	35	67	YES	84%
280	2025	30A	35A	35A	67	YES	75%

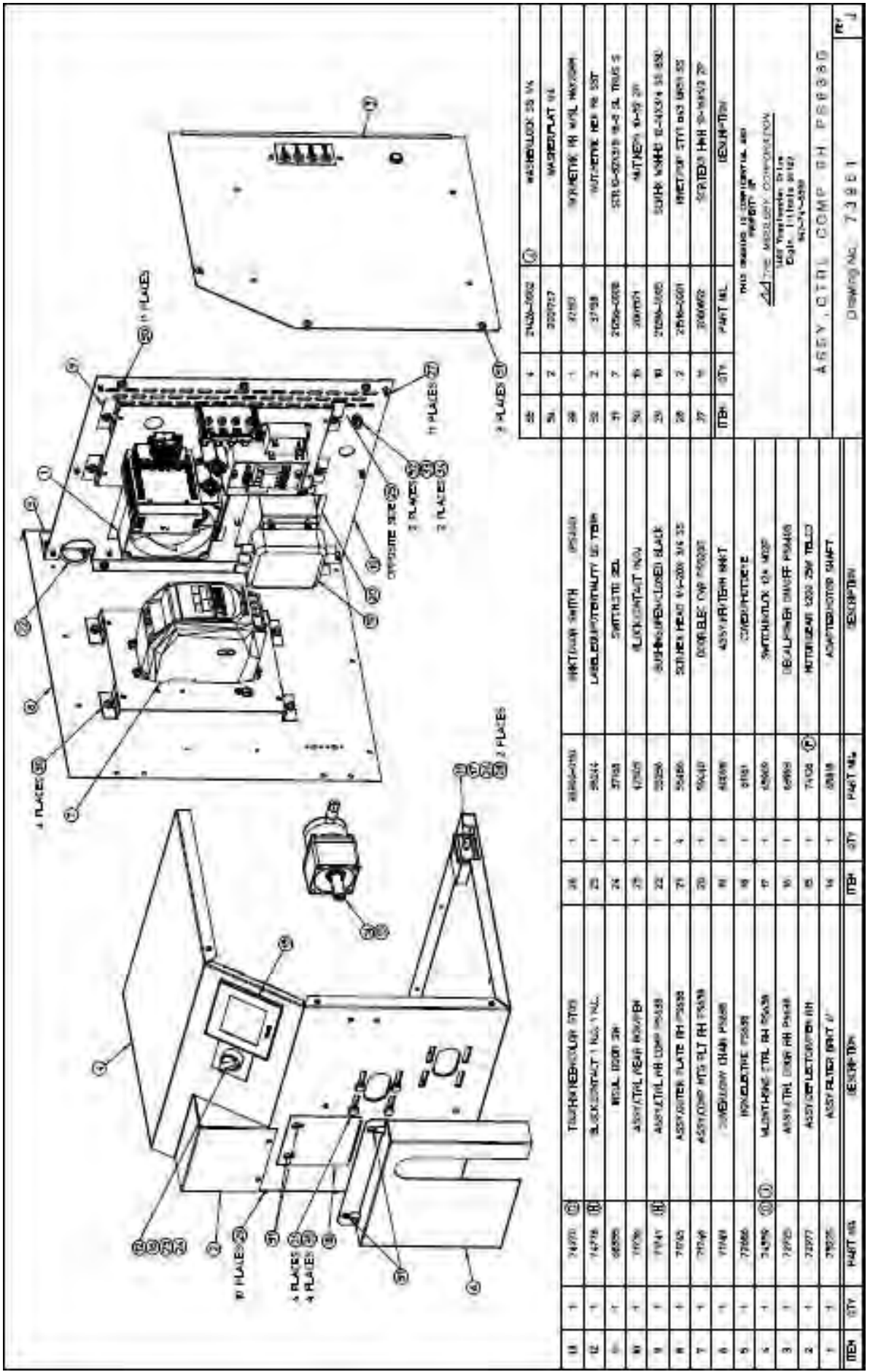

ITEM	QTY	PART NO.	DESCRIPTION	ITEM	QTY	PART NO.	DESCRIPTION
1	1	24270	TOUCHSCREEN LOW STOR	26	1	2029250	WRT (WRT) SMTH
2	1	74718	BUCK CONTACT 1 NO. 1 N.C.	27	1	20244	LABORATORY UTILITY SC TOPI
3	1	68205	WGL. 1000 2P	28	1	27103	SWITCH 22
4	1	71706	ASSY (TRL) REAR MOUNT BR	29	1	42509	BUCK CONTACT NO
5	1	71747	ASSY (TRL) RH COMP 15538	30	1	20256	SOFT-ENCLOSURE BLACK
6	1	71763	ASSY (TRN) PLATE RH 15532	31	4	50406	SOLENOID HEAD 1/4-20X 1/4 32
7	1	71749	ASSY (COMP) HTS SLT RH 15539	32	1	50408	SOLENOID COMP 15532E
8	1	71740	CONSOLE LOW (144) 15538	33	1	40208	ASSY (TRN) BRKT
9	1	72066	INDUCTIVE 15538	34	1	4101	CONDUCTIVE
10	1	74795	MONITORING CTRL RH 15538	35	1	40606	SWITCHLOCK 1/4 M3P
11	1	74795	ASSY (TRL) DGR RH 15538	36	1	68205	BEARING BRKT 15538
12	1	72077	ASSY (COLLECTOR) BR	37	1	71702	MOTOR/GEAR 1000 2HP TELCO
13	1	71705	ASSY (PLATE) BRKT U'	38	1	68118	ASSEMBLY MOTOR SHAFT
14	1	71705	ASSY (PLATE) BRKT U'				
15	1	71705	ASSY (PLATE) BRKT U'				
16	1	71705	ASSY (PLATE) BRKT U'				
17	1	71705	ASSY (PLATE) BRKT U'				
18	1	71705	ASSY (PLATE) BRKT U'				
19	1	71705	ASSY (PLATE) BRKT U'				
20	1	71705	ASSY (PLATE) BRKT U'				
21	1	71705	ASSY (PLATE) BRKT U'				
22	1	71705	ASSY (PLATE) BRKT U'				
23	1	71705	ASSY (PLATE) BRKT U'				
24	1	71705	ASSY (PLATE) BRKT U'				
25	1	71705	ASSY (PLATE) BRKT U'				
26	1	71705	ASSY (PLATE) BRKT U'				
27	1	71705	ASSY (PLATE) BRKT U'				
28	1	71705	ASSY (PLATE) BRKT U'				
29	1	71705	ASSY (PLATE) BRKT U'				
30	1	71705	ASSY (PLATE) BRKT U'				
31	1	71705	ASSY (PLATE) BRKT U'				
32	1	71705	ASSY (PLATE) BRKT U'				
33	1	71705	ASSY (PLATE) BRKT U'				
34	1	71705	ASSY (PLATE) BRKT U'				
35	1	71705	ASSY (PLATE) BRKT U'				
36	1	71705	ASSY (PLATE) BRKT U'				
37	1	71705	ASSY (PLATE) BRKT U'				
38	1	71705	ASSY (PLATE) BRKT U'				

THIS DRAWING IS CONTROLLED BY THE MILITARY COMPARISON UNIT, WASHINGTON, DC. DATE: 11/18/10. 10-1-10-1000

ASSY, CTRL COMP BR 15538
Drawing No. 73881

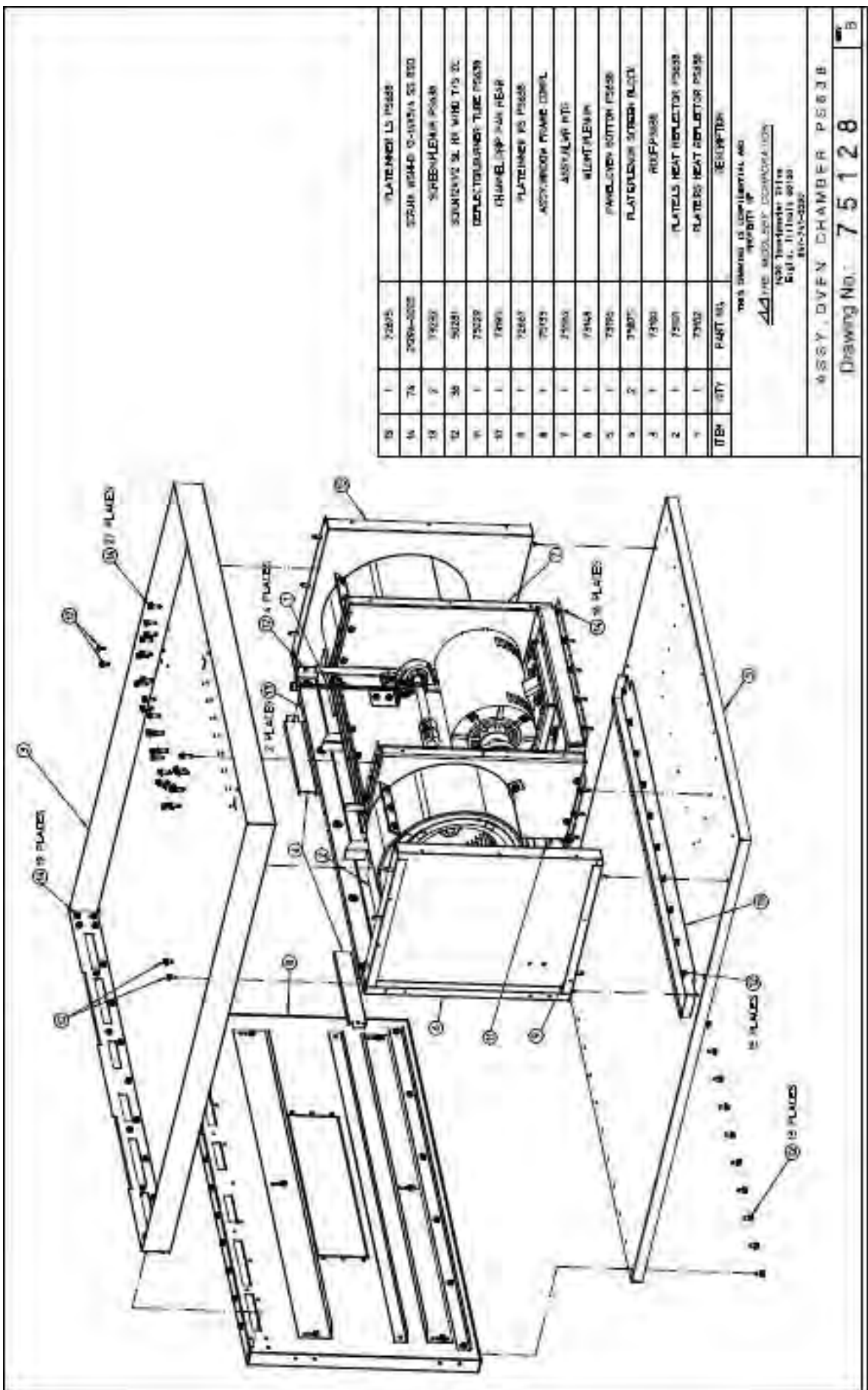

ITEM	QTY	PART NO.	DESCRIPTION
10	1	73275	PLATEHEAD L3 P5628
11	74	7094-0022	SCREW W/HEAD Q-10X1/4 SS STD
12	7	73227	SCREW-HELMER P5628
13	36	50281	SCREW 3/8 X 1/2 W/1/8 ZC
14	1	73229	REFLECTORINNER TUBE P5628
15	1	73676	CHIMNEY TOP P/IN REAR
16	1	73667	PLATEHEAD R3 P5628
17	1	73121	ASSEMBLY FRAME CORNER
18	1	73953	ASSEMBLY KIT
19	1	73144	W/INT/HELMER
20	1	73192	PAV/LOWER BOTTOM P5628
21	2	73077	PLATEHEAD SCREW BLOCK
22	1	73920	ROOF-P5628
23	1	73691	PLATEHEAD REFLECTOR P5628
24	1	73102	PLATEHEAD REFLECTOR P5628

THIS DRAWING IS CONFIDENTIAL AND PROPERTY OF
44 AND MODULAR CORPORATION
 5405 Tenthrediner Drive
 Dept. 1111111111
 800-555-0222

ASSY. OVEN CHAMBER P 5628 B

Drawing No.: **75128**

B

WARNING

Improper installation, adjustment, alteration, service or maintenance can cause property damage, injury or death. Read the installation, operating and maintenance instructions thoroughly before installing or servicing this equipment.

NOTICE

ALL parts replacement and appliance servicing should be performed by Your Middleby Marshall Authorized Service Agent. Service that is performed by parties other than Your Middleby Marshall Authorized Service Agent may void your warranty.

NOTICE

Using any parts other than genuine Middleby Marshall factory manufactured parts relieves the manufacturer of all warranty and liability.

NOTICE

Middleby Marshall reserves the right to change specifications at any time.

CFESA

Commercial Food Equipment Service Association

Middleby is proud to support the Commercial Food Equipment Service Association (CFESA). We recognize and applaud CFESA's ongoing efforts to improve the quality of technical service in the industry.

Middleby Cooking Systems Group • 1400 Toastmaster Drive • Elgin, IL 60120 • USA • (847)741-3300 • FAX (847)741-4406

www.middleby.com

