

Parts Manual

with Wiring Diagrams
for domestic ovens

Starting Serial # 943650206

Serial # Code (Nine Digit Code)
(for units produced prior to mid-July, 2006)
First 4 digits - order of production
Fifth digit - model specific
Sixth and Seventh digit - month of production
Eighth and Ninth digit - year of production

Serial # Code (Ten Digit Code)
(for units produced after to mid-July, 2006)
First 5 digits - order of production
Sixth digit - model specific
Seventh and Eighth digit - month of production
Ninth and Tenth digit - year of production

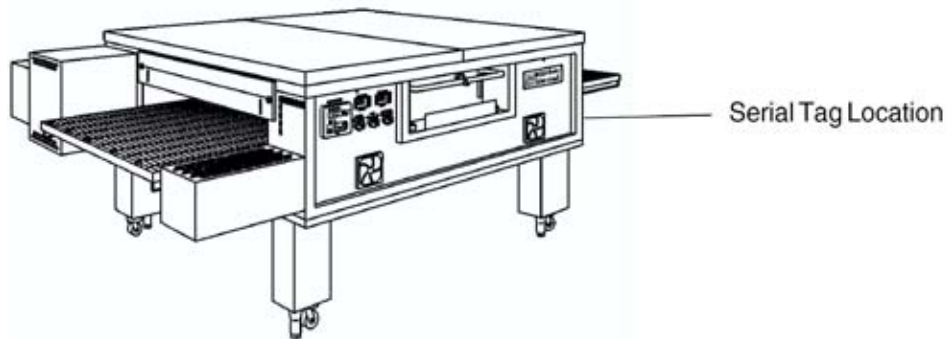

Table of Contents: Page 2



www.middleby.com
email: techsupport@middleby.com
1400 Toastmaster Drive
Elgin, IL 60120
1-847-741-3300 fax 1-847-741- 4406

Table of Contents

Spec Sheet	3
Key Parts	6
Cross Reference of Wiring Diagram Symbols and Part Number(s)	7
View of Installation Kit(s) and Base Kit(s)	8
Parts for Installation Kit(s) and Base Kit(s)	9
View of Oven Panels, End Plugs and Window	10
Parts for Oven Panels, End Plugs and Window	11
View of Gas Piping	12
Parts for Gas Piping	13
View(s) of Burner/Blower Motor Assembly	14
Parts for Burner/Blower Motor Assembly	15
View(s) of Front Control Area(s)	16
Parts for Front Control Area(s)	17
View of Rear Compartment and Blowers (Conveyor Drive End Shown)	18
Parts for Rear Compartment and Blowers (Conveyor Drive End Shown)	19
View of “Single” Belt Conveyor	20
Parts for “Single” Belt Conveyor	21
View of “Split” Belt Conveyor	22
Parts for “Split” Belt Conveyor	23
Standard Finger Configuration 58762E and Part Numbers	24
3-D View Finger Arrangement w/Part Numbers 58762-1 Rev. E.....	25
Thermocouple Placements 59077 Rev. G.....	26
Wiring Diagram, G208-240, 50/60Hz, 1 Phase 54745 Rev. I	27
Start Up Form PS770 Initial Start-Up/Check Out Procedures - Form # P/N 59279 Rev. “B” Dated 7/20/06 ..	28



**Papa John's
Exclusive**



PATENTS PENDING

Principle

Middleby Marshall PS Series Conveyor ovens bake both faster and at a lower temperature than other ovens. Patented vertical columns of hot air move heat aerodynamically instead of using high temperatures. The streams of hot air remove the boundary layers of cool heavy air which tend to insulate the product. This gives very rapid baking without burning. All PS770 WOW ovens are designed to cook Papa John's pizza at 4.5 minute Belt speed.

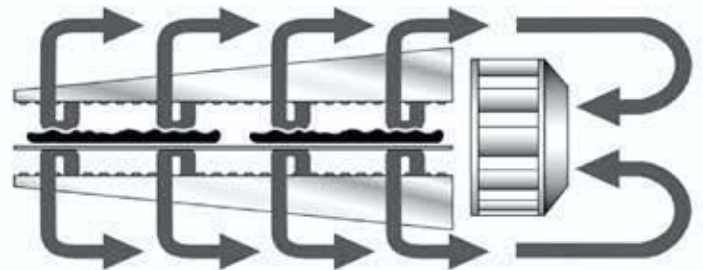

Standard Features

- **Impingement PLUS!** low oven profile and dual air return
- **Patented EMS Energy Management System** reduces gas consumption and increases cooking efficiency
- 70"/1778mm-long cooking chamber
- 32"/813mm-wide, 106"/2692mm-long conveyor belt

Optional Features

- Unique design allows the PS770 to bake all Papa John's menu items at 4.5 minute Belt speed.

Energy Management System

The PS770 features an Energy Management System (EMS) that automatically reduces gas consumption. Touch Screen Control can be programmed in three energy saving modes. Each mode gives the operator the ability to automatically reduce air velocity and temperature.

Cleanability

PS770 ovens are designed for easy cleaning. Removable parts include: crumb pans, end panels, air fingers, and a folding conveyor belt assembly.

Easily Serviced

Control compartment is designed for quick and easy access. All electrical controls are door-mounted.

Warranty

All PS770 models have a three year parts and labor warranty. Oven start-up and demonstration are included at no additional charge (USA only).

Ventilation

For installation under a ventilation hood only.

**PS770-2 Double Oven
with 15" (381mm) leg extensions**

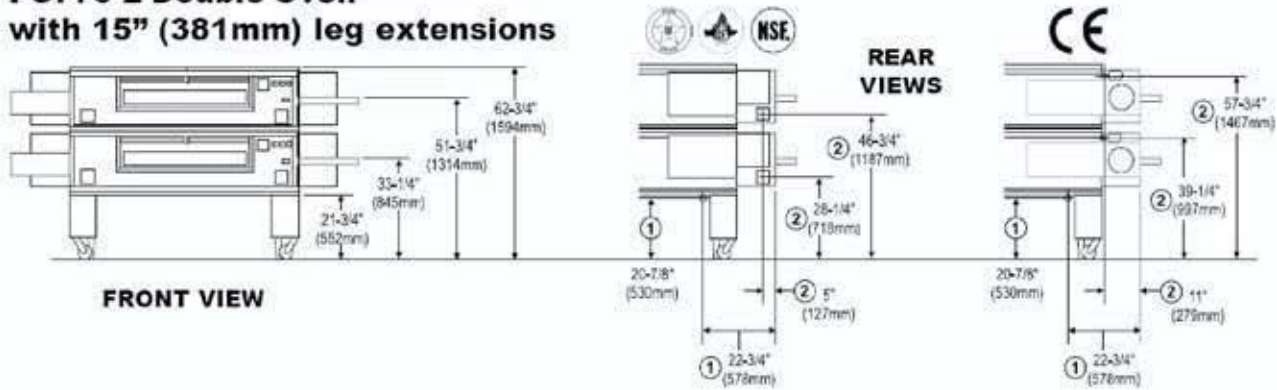

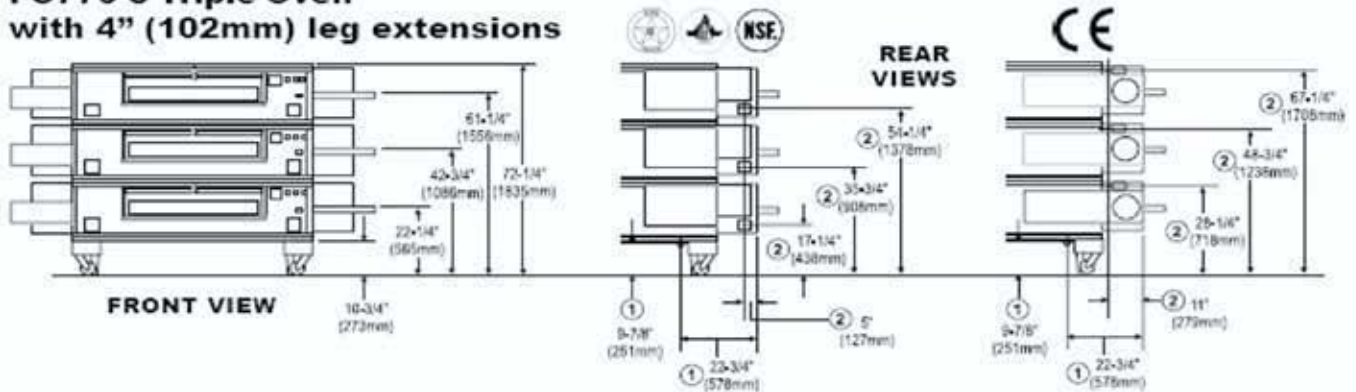

**PS770-3 Triple Oven
with 4" (102mm) leg extensions**



RECOMMENDED MINIMUM CLEARANCES

Rear of oven to wall	Control end of oven to wall	Non-control end of oven to wall
0" (0mm)	0" (0mm)	0" (0mm)

GENERAL INFORMATION

Model	Heating Zone	Baking Area	Belt Length	Belt Width	Depth 	Depth 	Height	Max. Operating Temp.	Bake Time Range	Ship Wt.	Ship Cube
PS770-1 with 19" (483mm) leg extensions	70" 1778mm	15.5 sq. ft. 1.44m ²	106" 2692mm	32" 813mm	61-3/4" 1568mm	63-3/8" 1610mm	48-1/4" 1226mm	550°F 288°C	4- 29-50	1750 lbs. 795kg	160 ft. ³ 4.5m ³
PS770-2 with 15" (381mm) leg extensions	140" 3556mm	31 sq. ft. 2.88m ²	106" 2692mm	32" 813mm	61-3/4" 1568mm	63-3/8" 1610mm	62-3/4" 1594mm	550°F 288°C	4- 29-50	3500 lbs. 1589kg	320 ft. ³ 9.0m ³
PS770-3 with 4" (102mm) leg extensions	210" 5334mm	46.5 sq. ft. 4.32m ²	106" 2692mm	32" 813mm	61-3/4" 1568mm	63-3/8" 1610mm	72-1/4" 1836mm	550°F 288°C	4- 29-50	5250 lbs. 2384kg	460 ft. ³ 13.5m ³

ELECTRICAL SPECIFICATIONS
Max Current Draw at Startup
Breakers

Model	Version	Voltage	Phase/Freq.	Supply	Amps	
PS770		208-240V	1,60 Hz	2 pole, 3 wire (2 hot, 1 gnd)	20A*	As per local codes

The average current draw during operation is significantly lower.

GAS SUPPLY SPECIFICATIONS

	Min. Gas Pipe Size	Supply Gas Pressure	Rated Heat Input
Natural Gas	2" (50.8mm) main One 1-1/4" (12.7mm) NPT branch to lower oven cavity with individual full-flow shutoff valve	6-12" W.C. (14.9-29.9 mbar)	(42,840 kcal, 50 kW/hr.) per oven cavity
Propane Gas	2" (50.8mm) main One 1-1/4" (12.7mm) NPT branch to lower oven cavity with individual full-flow shutoff valve	11-14" W.C. (27.4-34.9 mbar)	(42,840 kcal, 50 kW/hr.) per oven cavity

* The gas supply pressures shown are for ovens installed in North America. The required gas supply pressures of other locations are dependent on the local gas type and on all applicable local codes.

ALL SPECIFICATIONS SUBJECT TO CHANGE WITHOUT NOTICE.

KEY PARTS

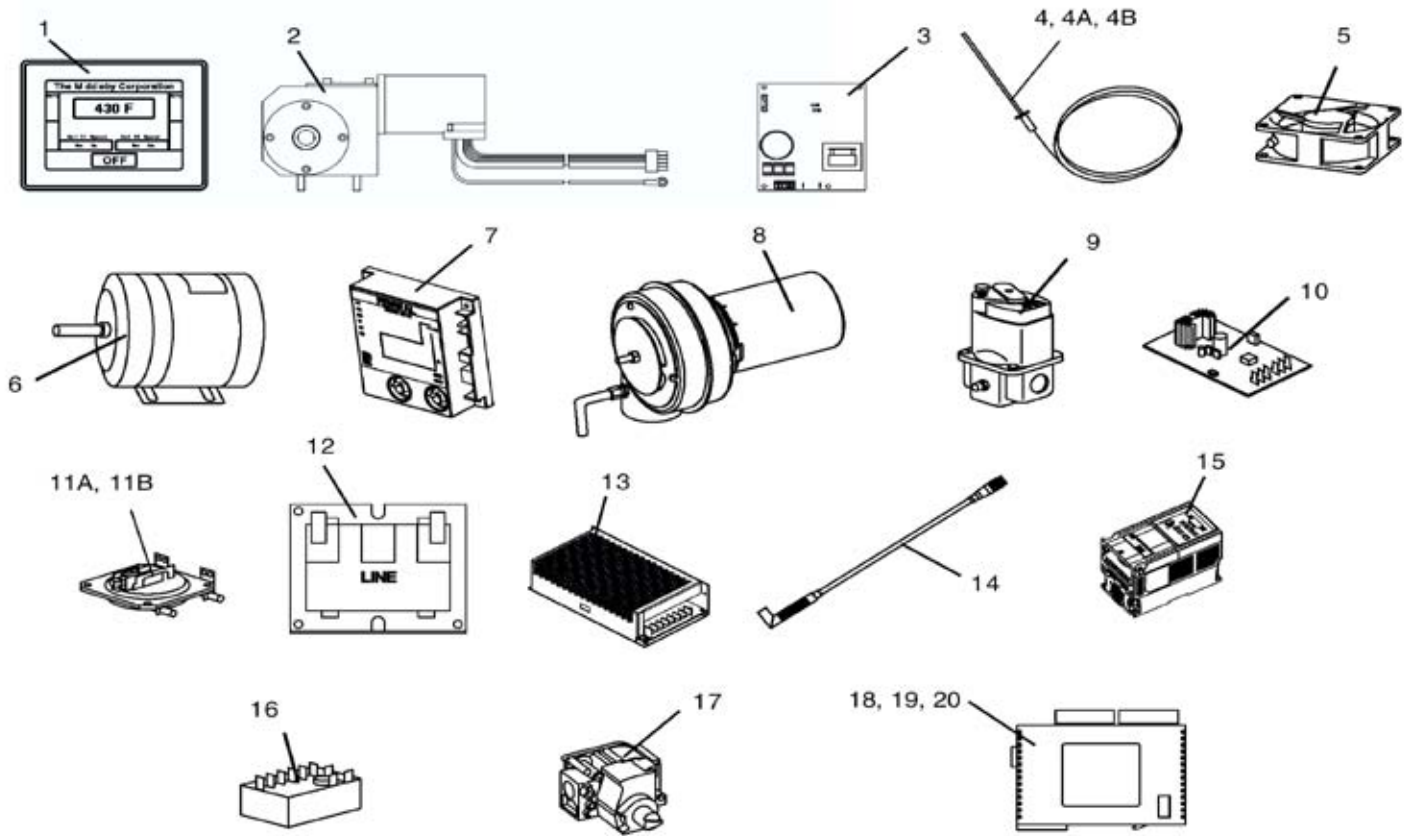

ITEM	PART NO.	DESCRIPTION	QUANTITY
1	59080	Display, Touch Screen	1
2	58678	Drive Motor, Conveyor, 1400:1, 130VDC	1 or 2
3	58679	Controller, Conveyor	1 or 2
4	33812-6	Thermocouple, 12" Temp. Control	4
4A	33812-8	Thermocouple, 2.5" Control Compartment	1
4B	33812-1	Thermocouple, 6" High Limit (33984)	1
5	M9616	Cooling Fan, 6", 24VDC	2
6	57288	Blower Motor, 2 hp, 1725 RPM	2
7	54727	Ignition Module, Dual	1
8	M9887	Burner/Blower Motor, 24VDC	1
9	59450	Modulating Gas Valve, 1/2" (41647)	2
10	31651	Amplifier Board	2
11A	50610	Air Switch, Rear Blower	2
11B	57141	Air Switch, Burner/Blower Motor, Front	1
12	32108	Transformer, 240V/24V, 65VA	2
13	M9608	Power Supply, 24VDC	1
14	59112	Photocell	1
15	59169	Inverter, 2 hp	2
16	33983	Hi Limit Control Module	1
17	54724	Gas Valve, Main, 1/2" Natural Gas	1
18	59082	Control Module, Digital, C14RS, Left	1
19	58668	Thermocouple Module, Digital, TC4, Middle	1
20	58669	Converter Module, Digital, A041, Right	1
21	58833	Flame Sensor	2
22	58834	Ignitor	2
23	58676	Control Cable-Touch Screen Display to PLC	1
24	59132	Relay-Glass	1
25	58777	Blower Belt	2
26	59198	Computer Cable Connects Main Oven Touch Screen to Customers Point of Sale (POS) Computer System	1

CROSS REFERENCE of WIRING DIAGRAM SYMBOLS and PART NUMBERS

• Air Switch 1 -Rear Right	50610	• Ignition Module, Dual	54727
• Air Switch 2 - Rear Left	50610	• Inverter - 1 Left, 2HP.....	59169
• Air Switch 3 - Front Right	57141	• Inverter - 2 right, 2 HP.....	59169
• Blower Motor-Left.....	57288	• Switch(es)	
• Blower Motor-Right	57288	• LS1 (LH RR), Momentary	28021-0061
• Burner Blower Motor	M9887	• LS2 (RH RR), Momentary	28021-0061
• Circuit Breakers		• LS3 (RH Front), Inter Lock.....	28021-0047
• CB1 - 15A.....	45037	• LS4 (LH Front), Inter Lock	28021-0047
• CB2 - 15A.....	45037	• Reset Button	35145
• CB3 - 15A.....	45037	• Mod Valve 1 (41647).....	59450
• CB4 - 15A.....	45037	• Mod Valve 2 (41647).....	59450
• CB5 - 3A.....	45036	• Photocell 1 Entrance.....	59112
• CB6 - 3A.....	45036	• Photocell 2 Exit	59112
• CB7 - 1A.....	45644	• Power Supply.....	M9608
• CB8 - 1A.....	45644	• Relay.....	59132
• Cooling Fan LH.....	M9616	• Signal Amplifier 1.....	31651
• Cooling Fan RH.....	M9616	• Signal Amplifier 2.....	31651
• Controller 1 DC	58679	• TB1 RR LT (3 Pole).....	44390
• Controller 1 DC (split belt).....	58679	• TB2 RR LT (3 Pole).....	44390
• Conveyor Motor	58678	• TB3 RR RT (3 Pole)	44390
• Conveyor Motor (split Belt).....	58678	• TB4 RR LT (8 Pole).....	31047
• Dual Burner	54719	• TB5 Comp Brkt (4 Pole)	M0593
• Converter Module - Digital A041, Right.....	58669	• TB6 Comp Brkt (4 Pole)	M0593
• Control Module - Digital C14RS-A, Left.....	59082	• TC1 - 6" High Limit (33984)	33812-1
• Thermocouple Module - Digital TC4, Middle	58668	• TC2 - 12", Oven Temp.	33812-6
• Gas Valve.....	54724	• TC3 - 12", Oven Temp.	33812-6
• Green Light (Reset Button)	35145	• TC4 - 2.5", Control Compartment.....	33812-8
• GT30 Display	59080	• XFMR1 - 240V/24V 65 VA.....	32108
• High Limit	33983	• XFMR2 - 240V/24V 65 VA.....	32108

Wiring Diagram Drawing # 54745 Rev. I Shown on Page 27.

SET THE ENERGY MODES TO THE FOLLOWING SETTINGS AS OF 3/08/2007

OVEN WITH POS COMPUTER CABLE

MODE 2--7:00 MINUTES
 MODE 3--14:00 MINUTES
 MODE 4--1 HOUR

OVEN WITHOUT POS CABLE

MODE 2--7:00 MINUTES
 MODE 3--20:00 MINUTES
 MODE 4--1 HOUR

(This is a "CONTROLLED" Screen-Password Required)

VIEW OF INSTALLATION KIT (PART NUMBER 59057)

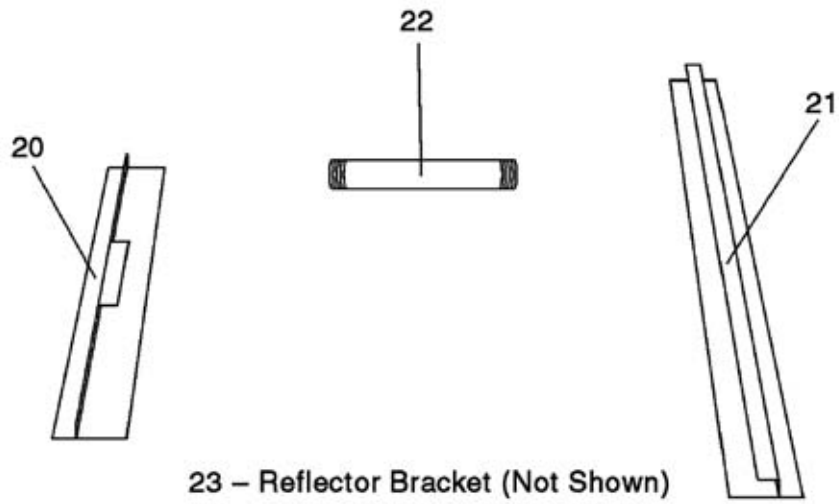

VIEW OF BASE PAD KIT

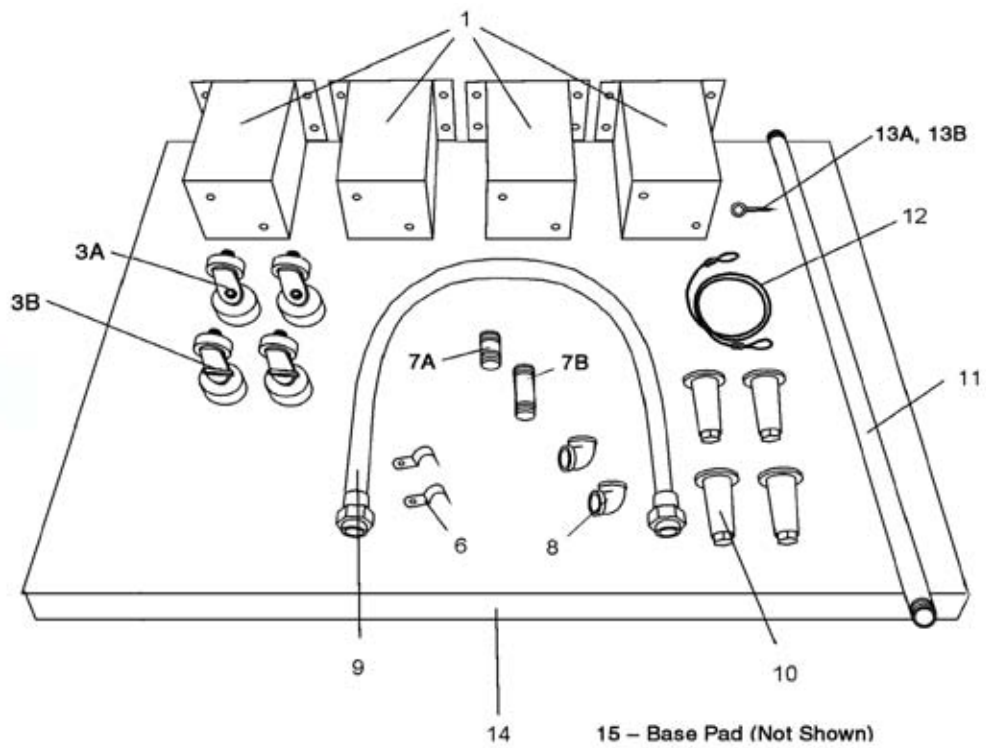

Parts for INSTALLATION KIT (Part Number 59057)

ITEM	QTY. - SGL. BELT	P/N	DESCRIPTION
20	1	55028	CONVEYOR REAR STOP, 18"
21	1	55027	CONVEYOR END STOP, 29-1/4"
22	1	33120-0053	GAS PIPE NIPPLE, 1-1/4" X 9-1/2"
23	1	59419	BRACKET, REFLECTOR, R.H.

ITEM	QTY. SGL. OVEN 19" LEGS 59285	QTY. SGL./DBL. OVEN/W 15" LEGS 59244	QTY. TRIPLE OVEN 59243	P/N	DESCRIPTION
1A	4	—	—	37210-0060	LEG, 19" (483mm) (OPTIONAL)
1C	—	4	—	37210-0057	LEG, 15" (381mm)
1D	—	—	4	39684	LEG, 4" (102mm) (43158, set of 4)
3A	2	2	2	37115-0102	CASTER, SWIVEL WITH 3/4" STUD
3B	2	2	2	58930	CASTER, SWIVEL WITH BRAKE
6	2	2	2	27271-0004	PIPE CLAMP, 1-1/2"
7A	2	2	2	33120-0055	NIPPLE, 1-1/4" DIA. X 3" L, NPT
7B	1	1	1	33120-0054	PIPE, 1-1/4" DIA. X 6" L
7C	2	2	2	59910	GAS PIPE 1-1/4" DIA x 4"
8	2	2	2	23122-0007	ELBOW, 90°, 1-1/4" DIA.
9	1	1	1	22361-0003	GAS HOSE, 1-1/4" DIA. x 72" L
10	4	4	4	22450-0028	LEG, 6" (152mm) ADJUSTABLE WITH 3/4" STUD
11	1	1	1	33120-0056	GAS PIPE, 1-1/4" DIA. x 54" L
12	1	1	1	22450-0253	RESTRAINT CABLE, 60" (1524mm)
13A	1	1	1	21392-0005	EYE BOLT, WALL
13B	1	1	1	37699	EYE BOLT, BASE PAD
14	2	2	2	35210-0656	TOP COVER (RIGHT OR LEFT)

NOT SHOWN:

15	1	1	1	37210-0055	BASE PAD
16	2	2	2	21292-0001	SCREW, TEKS HWH #2PT #10-16 x 3/4"
17	16	16	—	21216-0018	BOLT, HEX CAP 1/2"-13 x 1-1/4"
18	16	16	-	21416-0003	FLAT WASHER, 1/2"
19	16	16	-	21426-0004	LOCK WASHER, 1/2"
20	8	8	8	59156	SCREW S/S TOP-1 1/2"
21	1	1	1	59198	COMPUTER CABLE 39" LONG CONNECTS MAIN OVEN TOUCH SCREEN TO CUSTOMER'S POINT OF SALE (POS) COMPUTER SYSTEM

View of PANELS, END PLUGS and WINDOW

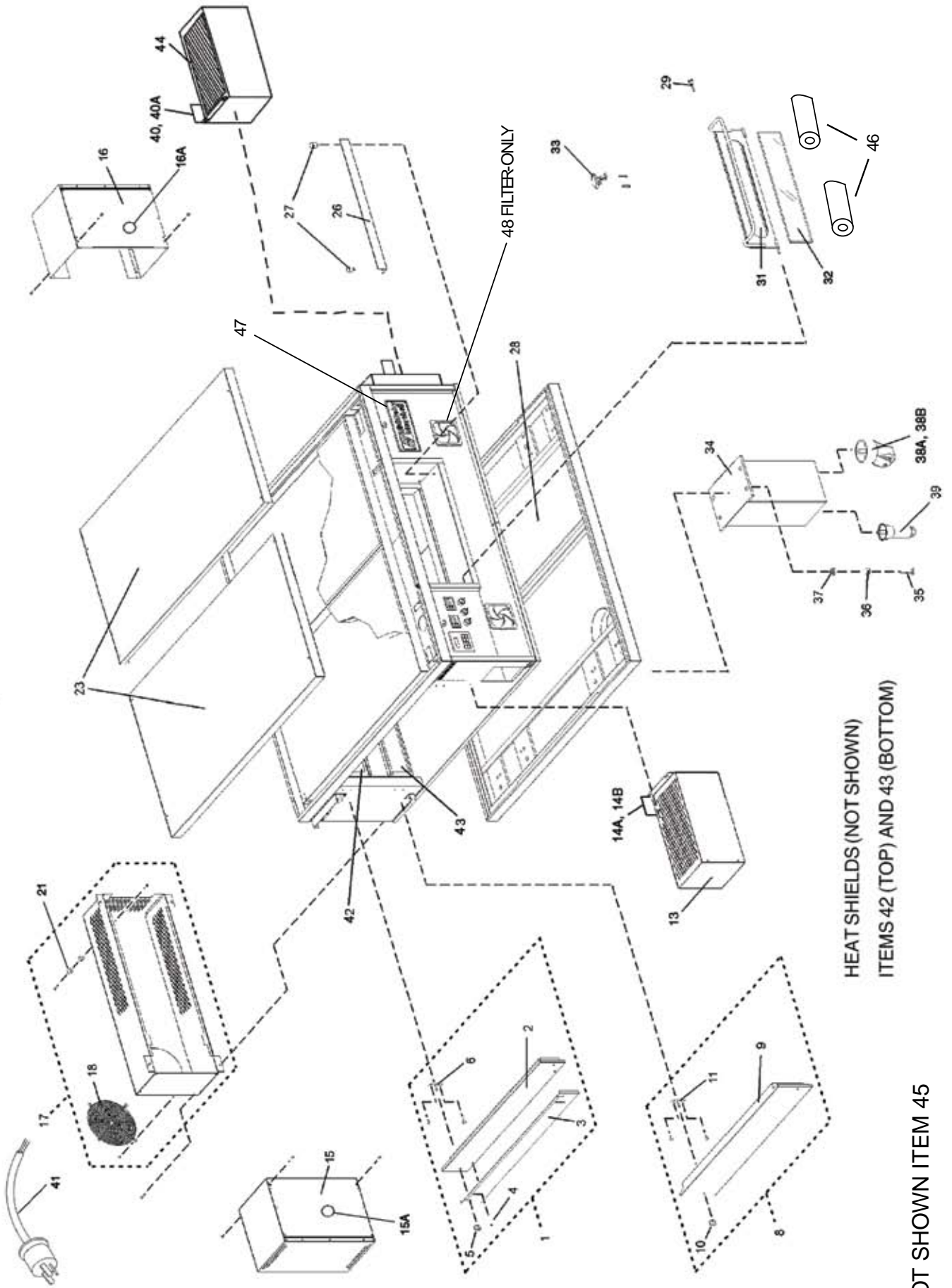

HEAT SHIELDS (NOT SHOWN)
ITEMS 42 (TOP) AND 43 (BOTTOM)

NOT SHOWN ITEM 45

EARLIER MODELS REQUIRED A RIGHT TO LEFT KIT TO CONVERT TO LEFT OPERATION PART #59340

Parts for PANELS, END PLUGS and WINDOW

ITEM	QTY.	P/N	DESCRIPTION
1	1	39539	ASSY, UPPER END PLUG (INC. ITEMS 2-6)
2	2	41778	WELDMENT, UPPER END PLUG
3	2	50834	EYEBROW
4	8	220295	SCREW, "AB" HEX WSHR HD #10 X 3/4"
5	4	36452	WING NUT, 1/4"-20 W/PLASTIC GRIP
6	4	41708	PLATE, END PLUG MOUNTING
8	2	39569	ASSY, LOWER END PLUG (INC. ITEMS 9-11)
9	2	41779	WELDMENT, LOWER END PLUG PS500
10	4	36452	WING NUT, 1/4"-20 W/PLASTIC GRIP
11	4	41708	PLATE, END PLUG MOUNTING
13	1	57501	ASSEMBLY, DRIVE MOTOR SHROUD
14A	1	59098	BRACKET FOR REFLECTOR
14B	1	59099	REFLECTOR
15	1	57286	ASSEMBLY, LEFT MOTOR SHROUD
15A	1	58758	GLASS, 2"x2" x 0.25"
16	1	57293	ASSEMBLY, RIGHT MOTOR SHROUD
16A	1	58758	GLASS, 2"x2" x 0.25"
17	2	54715	ASSEMBLY, REAR SHROUD (INC. ITEM 18 & 19)
18	2	31765	GRILL, COOLING FAN
21	2	48522	SPACER
23	2	35210-0656	TOP COVER
26	1	42488	WINDOW GUARD
27	2	30927	BUMPER, WINDOW

ITEM	QTY.	P/N	DESCRIPTION
28	1	37210-0055	BASE PAD
29	2	34121-0003	SCREW, WINDOW PIVOT
31	1	45012	ASSEMBLY, WINDOW/LATCH (INC. ITEM 32 & 33)
32	1	41597	GLASS, WINDOW, PRE-CUT, 3-1/2" X 20"
33	1	45087	LATCH
34A	4	37210-0060	LEG, 19"
34B	4	37210-0057	LEG, 15"
34C	4	39684	LEG, 4"
35	16	21216-0018	BOLT, HEX CAP 1/2"-13 X 1-1/4" - SINGLE & DOUBLE OVENS
36	16	21426-0004	LOCKWASHER, 1/2" - SGL & DBL OVENS
37	16	21416-0003	FLAT WASHER, 1/2" - SGL & DBL OVENS
38A	2	37115-0102	CASTER, SWIVEL WITH 3/4" STUD - SINGLE, DOUBLE, & TRIPLE OVENS
38B	2	58930	CASTER, SWIVEL WITH BRAKE
39	4	22450-0028	LEG, 6" (152mm) ADJUSTABLE WITH 3/4" STUD - SINGLE, DOUBLE, & TRIPLE OVENS
40	1	59098	BRACKET, REFLECTOR, RIGHT HAND
40A	1	59099	REFLECTOR
41	1	49975	CORD & PLUG, L6-20P
42	2	59048	HEAT SHIELD, TOP.
43	2	59049	HEAT SHIELD, BOTTOM
44	1	59226	ASSEMBLY, SHROUD, RIGHT HAND
45	1	59340	RIGHT TO LEFT DIRECTION KIT-EARLY MODELS PRODUCED BEFORE 09/06
46	2	59562	COOL HANDLE INSULATOR
47	1	58764	MIDDLEBY LOGO
48	2	310-2468	FILTER ONLY

View of GAS PIPING

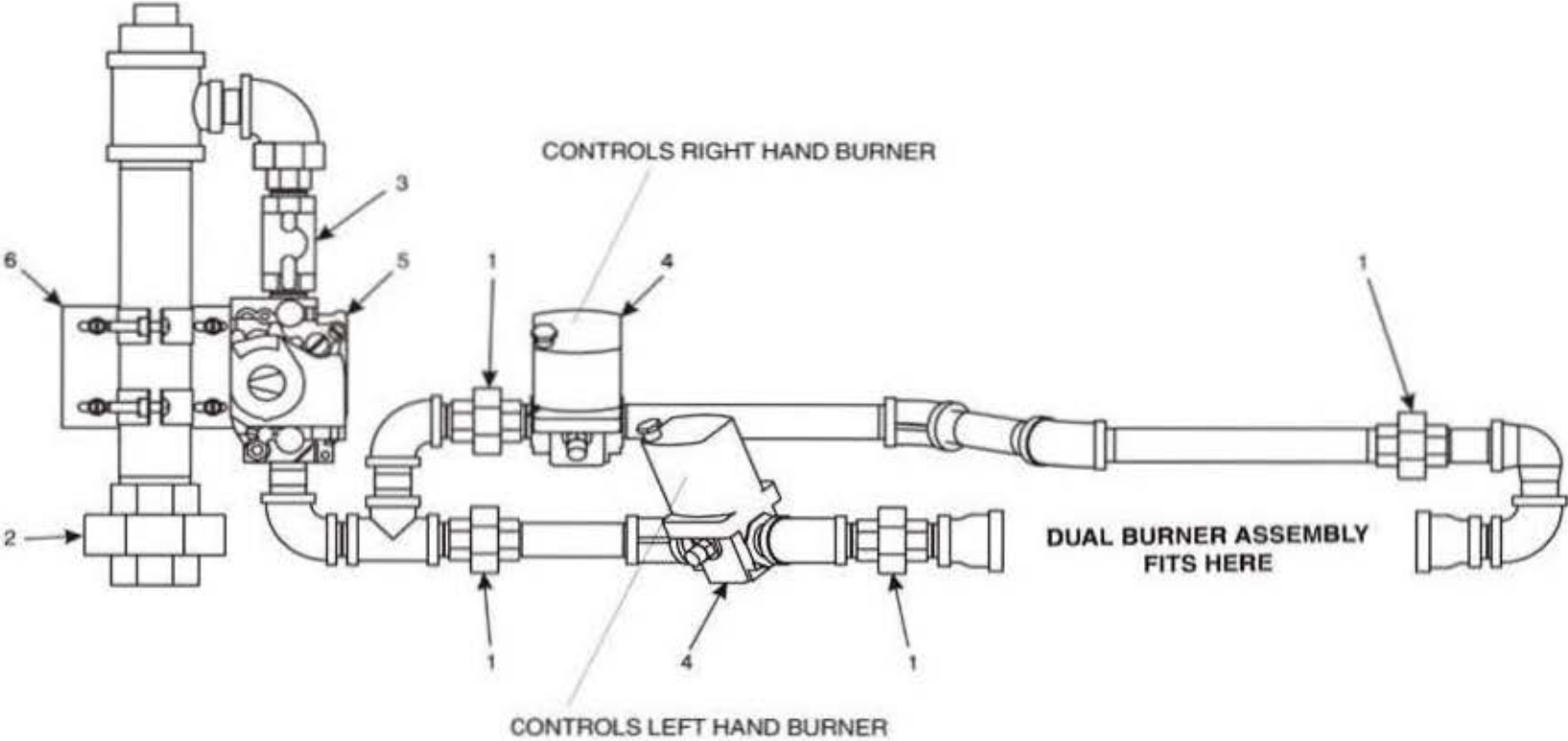

Parts for GAS PIPING

ITEM	QTY.	P/N	DESCRIPTION
1	4	23051-0003	UNION, 1/2"
2	1	23051-0012	UNION, 1-1/4"
3	1	23115-0009	MANUAL ON/OFF GAS VALVE, 1/2", BALL
4	2	59450	MODULATING GAS VALVE, 1/2" (41647)
5	1	54724	VALVE, COMBINATION, 1/2" - NATURAL GAS
5A	1	28092-0018	SPRING FOR LP CONVERSION
6	1	42410-0016	BRACKET/CLAMP

View of BURNER/BLOWER MOTOR ASSEMBLY

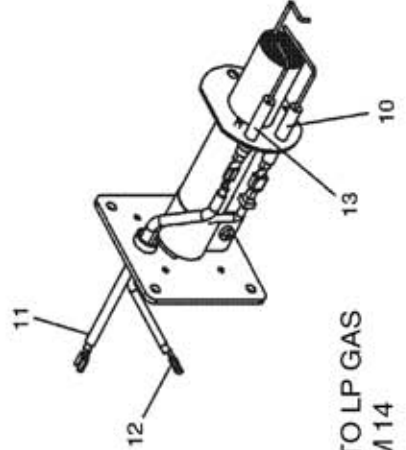
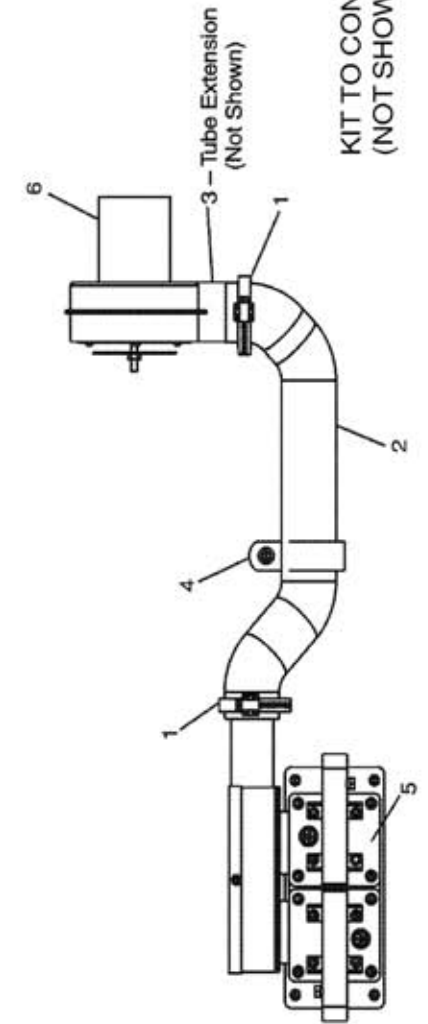
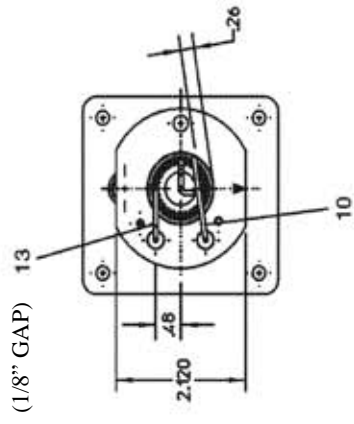
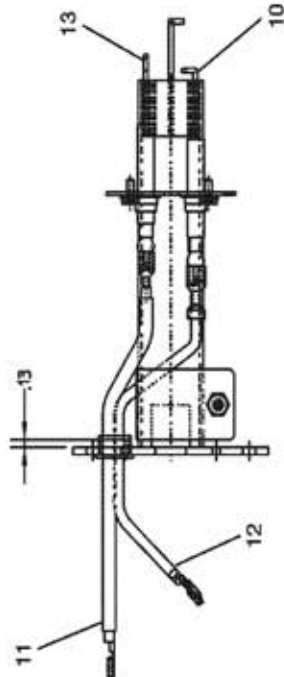
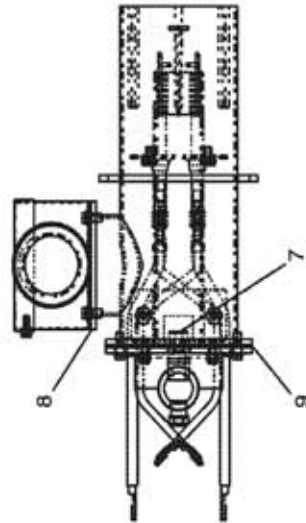
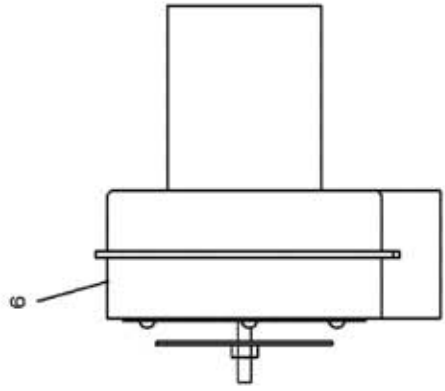
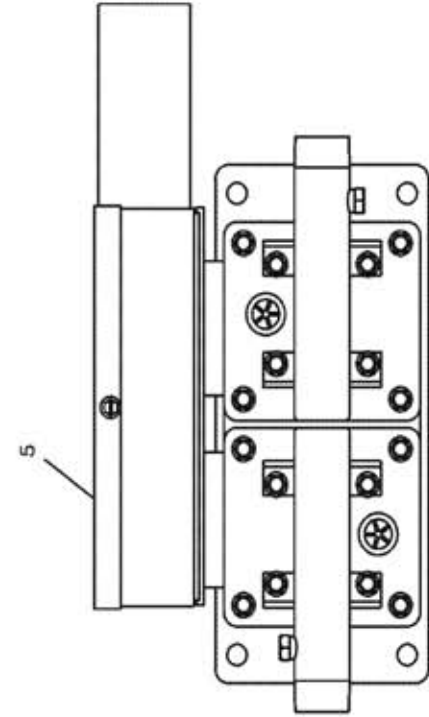
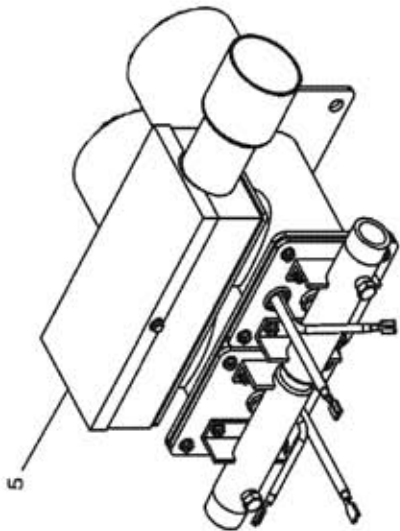

**KIT TO CONVERT TO LP GAS
(NOT SHOWN) ITEM 14**

Parts for BURNER/BLOWER MOTOR ASSEMBLY

ITEM	QTY.	P/N	DESCRIPTION
1	2	22450-0259	CLAMP, DUCT
2	1	22450-0255	DUCT
3	1	35210-0053	TUBE EXTENSION <i>(Not Shown)</i>
4	1	58754	CLAMP
5	1	54719	DUAL ASSEMBLY BURNER <small>(AS OF 4/1/07 - TARGETS AREA POSITIONED INSIDE BURNER TUBES)</small>
6	1	M9887	BURNER/BLOWER MOTOR, 24V DC
7	2	Contact Factory	ORIFICE, NATURAL GAS, .173, #17
8	1	Contact Factory	GASKET, AIR INTAKE
9	1	Contact Factory	GASKET, DUAL VERTURE
10	2	58833	ELECTRODE, FLAME SENSOR
11	2	58836	WIRE, IGNITION, 27" LONG, 5mm
12	2	58835	WIRE, FLAME SENSOR, 36" LONG
13	2	58834	IGNITOR, ELECTRODE - 1/8" GAP
14	1	Contact Factory	KIT TO CONVERT TO LP
14A	2	59074	ORIFICE, LP, .118
14B	1	28092-0018	SPRINGFOR GAS VALVE
15	1	Contact Factory	KIT TO CONVERT TO NAT GAS

View of FRONT CONTROL AREA(S)

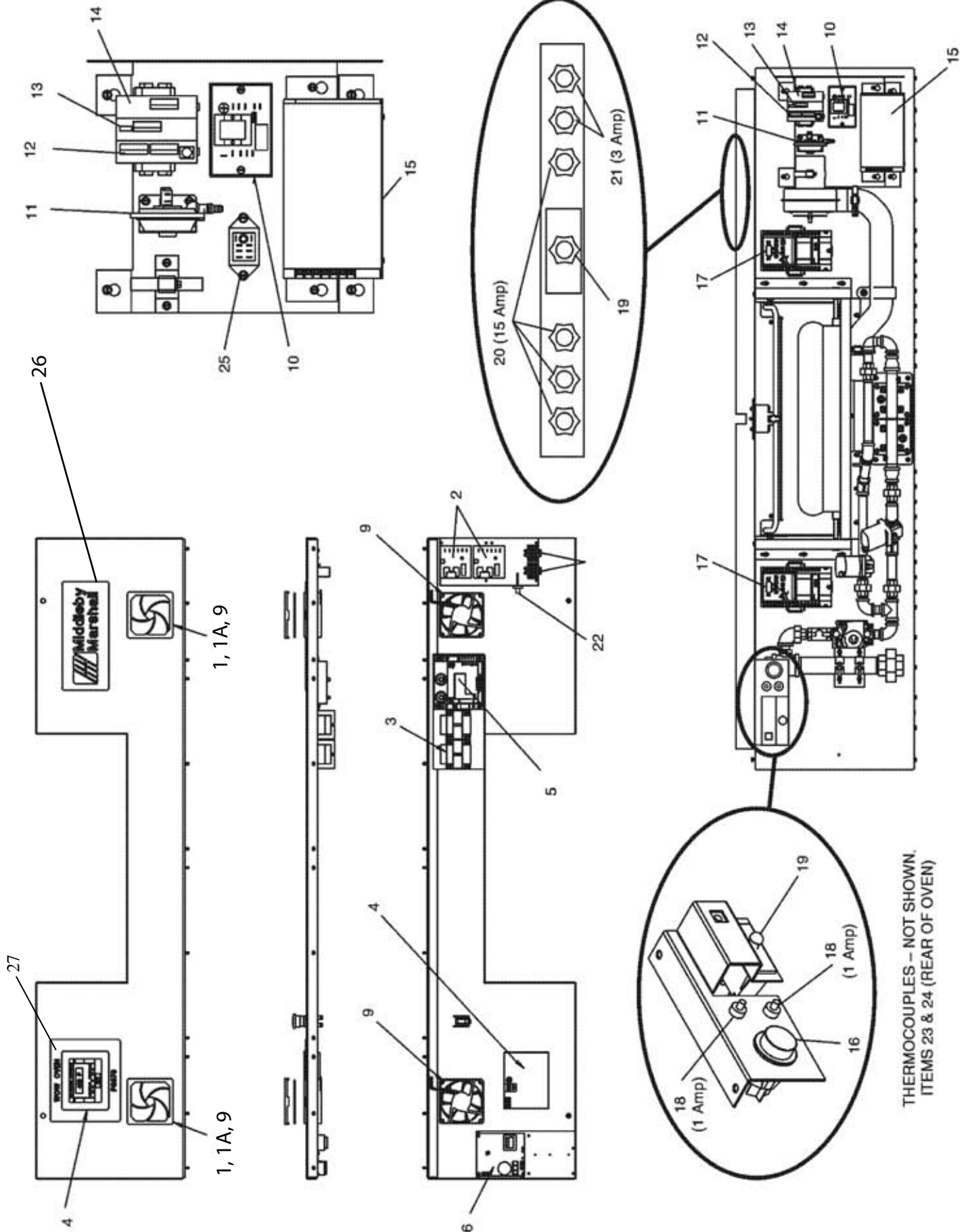

THERMOCOUPLES - NOT SHOWN.
ITEMS 23 & 24 (REAR OF OVEN)

Parts for FRONT CONTROL ARES(s)

ITEM	QTY.	P/N	DESCRIPTION
1	2	310-2458	FILTER/GUARD, FAN
1A	2	310-2468	FILTER ONLY
2	2	31651	AMPLIFIER BOARD
3	2	32108	TRANSFORMER, 240/24V, 65VA
4	1	59080	TOUCH SCREEN DISPLAY
5	1	54727	DUAL IGNITION MODULE
6	1or 2	58679	CONTROLLER, CONVEYOR
8	2	M0593	TERMINAL BLOCK, 2-POLE
9	2	M9616	COOLING FAN, 24VDC
10	1	33983	HI-LIMIT CONTROL
11	1	57141	AIR SWITCH, FRONT, BURNER/BLOWER
12	1	59082	CONTROL, (LEFT-HAND), DIGITAL, C14RS
13	1	58668	THERMOCOUPLE (MIDDLE), CONTROL, TC4
14	1	58669	CONVERTER, (RIGHT-HAND), A041
15	1	M9608	POWER SUPPLY, 24VDC
16	1	35145	RESET SWITCH W/GREEN LIGHT, HI-LIMIT
17	2	59169	INVERTOR -PROGRAMMED
18	2	45644	CIRCUIT BREAKER, 1 AMP
19	2	28021-0047	SWITCH, INTERLOCK
20	4	45037	CIRCUIT BREAKER, 15 AMP
21	2	45036	CIRCUIT BREAKER, 3 AMP
22	1	33812-8	THERMOCOUPLE, 2.5" x 60", CONTROL COMPARTMENT
23	4	33812-6	THERMOCOUPLE, 12" x 120", REAR OF OVEN
24	1	33812-1	THERMOCOUPLE 6" (HIGH LIMIT) REAR OF OVEN (33984)
25	1	59132	RELAY, DPDT, 24VDC COIL
26	1	58764	MIDDLEBY LOGO
27	1	58980	LABEL-WOW OVEN -PS770

View(s) of REAR COMPARTMENT AND BLOWER (CONVEYOR DRIVE END SHOWN)

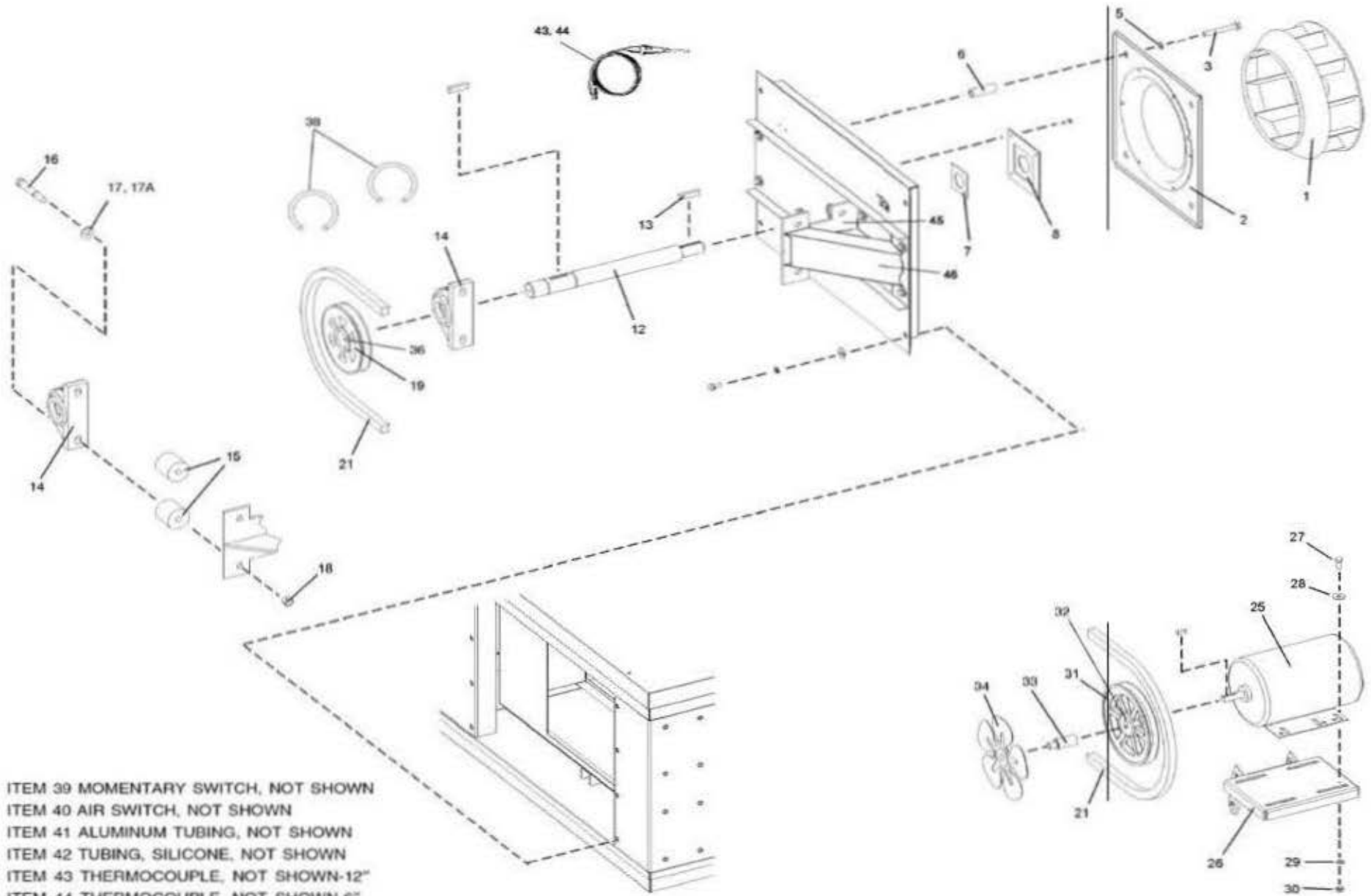

- ITEM 39 MOMENTARY SWITCH, NOT SHOWN
- ITEM 40 AIR SWITCH, NOT SHOWN
- ITEM 41 ALUMINUM TUBING, NOT SHOWN
- ITEM 42 TUBING, SILICONE, NOT SHOWN
- ITEM 43 THERMOCOUPLE, NOT SHOWN-12"
- ITEM 44 THERMOCOUPLE, NOT SHOWN-6"
- ITEM 47 PHOTO CELL
- ITEM 48 MOUNTING BRACKET, PHOTO CELL

NOTE: IDENTIFY THE DEFECTIVE INNER FROM THE DEFECTIVE OUTER BEARING ITEM 14 PER ENGINEERING'S REQUEST (THESE PARTS ARE TO BE RETURNED FOR OUR INSPECTION)

Parts for EACH REAR COMPARTMENT AND BLOWER

ITEM QTY.	P/N	DESCRIPTION
1A 1	22521-0005	BLOWER WHEEL, IDLER END
1B 1	22521-0006	BLOWER WHEEL, CONVEYOR DRIVE END
2 1	37210-0124	PLATE, INLET RING
3 4	21211-0001	SCREW, CAP HEX HD 3/8"-16 x 3"
5 10	21422-0001	LOCKWASHER, SPLIT 3/8"
6 4	35210-0576	SPACER
7 1	35210-0541	SHAFT SEAL, PTFE
8 1	37210-0101	PLATE, SHAFT SEAL INNER
12 1	57323	SHAFT BLOWER
13 1	35210-0286	KEY, BLOWER WHEEL
14 2	57321	BEARING
15 4	57320	SPACER, BEARING
16 4	2000535	SCREW, CAP HEX HD
17 4	A6235	FLATWASHER, 7/17"
17A 4	21422-0016	LOCKWASHER
18 4	21121-0013	HEX NUT, 1/2"-13
19 1	57295	PULLEY, 5"
21 1	58777	BELT
25 1	57288	MOTOR, BLOWER 2HP
26 1	59133	BRACKET, MOTOR MOUNTING
27 4	6673	SCREW, CAP HEX HD 5/16"-18 x 1"

ITEM QTY.	P/N	DESCRIPTION
28 4	A3682	LOCKWASHER, SPLIT 5/16"
31 1	57296	PULLEY, 5.6"
32 1	57297	INSERT, 5/8"
33 1	43024	EXTENDER, FAN
34A 1	27399-0008	FAN BLADE, CW, 8", CONVEYOR DRIVE END
34B 1	27399-0009	FAN BLADE, CCW, 8", IDLER END
35 1	57316	BRACKET, MOTOR SUPPORT
36 1	57298	INSERT, 1-7/16"
37 1	Contact Factory	KEY, 5/8 x 1
38 2	57325	RING
39 1	28021-0061	SWITCH, MOMENTARY
40 1	50610	AIR SWITCH
41 AP	15125-0002	ALUMINUM TUBING
42 AP	22450-0297	TUBING, SILICONE
43 4	33812-6	THERMOCOUPLE, 12" x 120", REAR OF OVEN
44 1	33812-1	THERMOCOUPLE 6" (HIGH LIMIT) (33984)
45 1	41575	MOUNTING BRACKET
46 1	44550	SUPPORT BRACKET
47 1	59112	PHOTO CELL, 24V DC
48 1	59108	MOUNTING BRACKET, PHOTO CELL

View of Single-Belt Conveyor

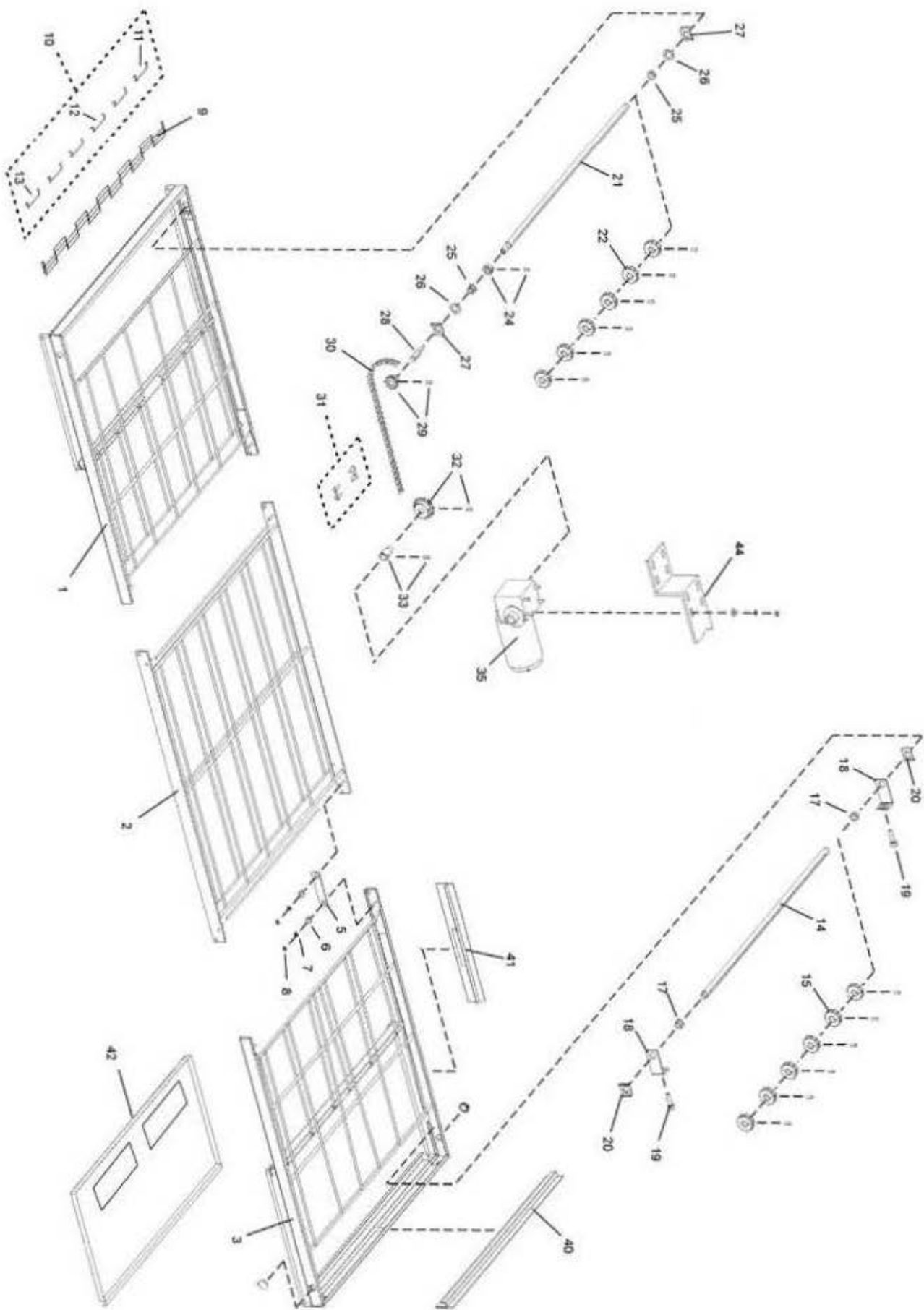

Parts for Single-Belt Conveyor

ITEM	QTY	PART NO.	DESCRIPTION
1	1	37210-0117	WELDMENT, CONVEYOR DRIVE FRAME
2	1	37210-0046	WELDMENT, CONVEYOR CENTER FRAME
3	1	37210-0116	WELDMENT, CONVEYOR IDLER FRAME
5	4	35210-0429	PIVOT PLATE
6	8	35210-0491	BUSHING, CONVEYOR ADJUSTMENT
7	8	F716A8805	WASHER, EXTERNAL TOOTH 1/4"
8	8	21176-0001	LOCKNUT, HEX 1/4"-20
9A	1	22450-0265	CONVEYOR BELT, COMPLETE, 32"W x 206"L
9B	--	33900-0032	CONVEYOR BELT, 32"W x 12"L (0.81 x 0.30m)
10	1	51380	MASTERLINKS KIT, 32" (0.81m) BELT (INC. ITEMS 11-13)
11	1	--	MASTERLINK, LEFT
12	4	--	MASTERLINK, CENTER
13	1	--	MASTERLINK, RIGHT
14	1	35000-1011	SHAFT, IDLER
15	6	22229-0003	SPROCKET, CONVEYOR BELT
17	2	22034-0003	BUSHING, BRONZE 3/4" O.D. x 5/8" I.D.
18	2	37000-0413	BRACKET, IDLER SHAFT ADJUSTMENT
19	2	35000-1008	SCREW, CONVEYOR TENSION ADJUSTMENT
20	2	54947	BRACKET, SHAFT SUPPORT
21	1	35000-1012	SHAFT, DRIVE

ITEM	QTY	PART NO.	DESCRIPTION
22	6	22229-0003	SPROCKET, CONVEYOR BELT
24	1	22011-0013	COLLAR, SHAFT, WITH SET SCREW
25	2	22034-0003	BUSHING, BRONZE 3/4" O.D. x 5/8" I.D.
26	2	35000-1080	SPACER, NYLON 1-1/4" O.D. x 3/4" I.D.
27	2	54947	BRACKET, SHAFT SUPPORT
28	1	35000-1013	ADAPTER, DRIVE SHAFT
29	1	22152-0017	SPROCKET, DRIVE SHAFT, 5/8" BORE, 9T, WITH SET SCREW
30	1	42400-0164	ASSEMBLY, ROLLER CHAIN (62 LINKS) WITH MASTERLINK
31	1	22273-0001	MASTERLINK, ROLLER CHAIN
32	1	22152-0018	SPROCKET, DRIVE MOTOR, 5/8" BORE, 15T, WITH SET SCREW
33	1	35210-0640	ADAPTER, DRIVE MOTOR WITH SET SCREW
35	1	58678	DRIVE MOTOR, BRUSHLESS, 1400:1 130VDC
40	1	55027	END STOP, CONVEYOR, 29-1/4" LONG
41	1	55028	REAR STOP, CONVEYOR, 18" LONG
42	2	30004	CRUMB PAN
43	1	M10098	HARNESS, WIRE
44	1	45035	MOUNTING BRACKET, DRIVE MOTOR

View of "SPLIT" Belt Conveyor

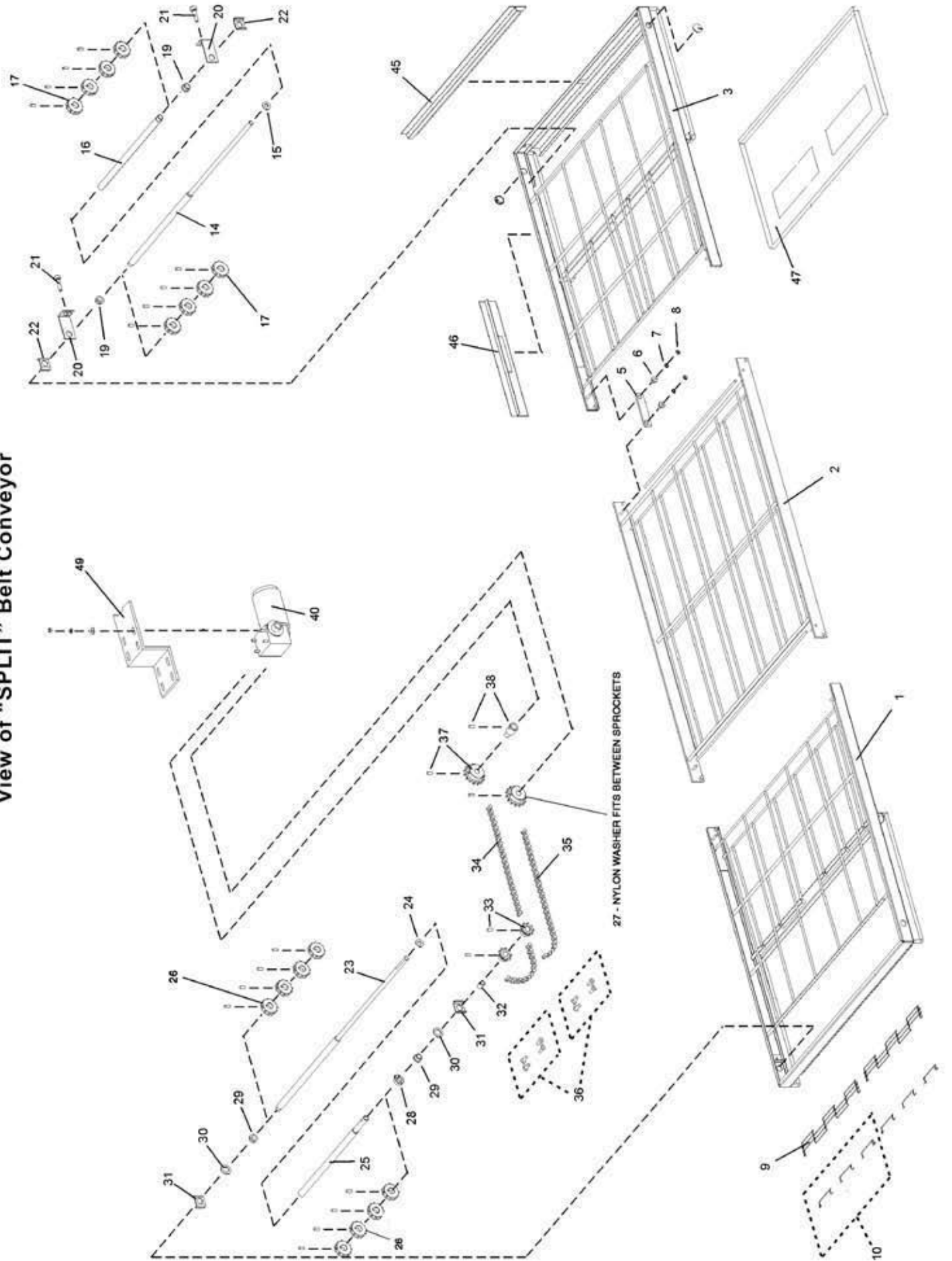

Parts for "SPLIT" Belt Conveyor

ITEM	QTY	PART NO.	DESCRIPTION	ITEM	QTY	PART NO.	DESCRIPTION
1	1	37210-0117	WELDMENT, CONVEYOR DRIVE FRAME	26	8	22229-0003	SPROCKET, CONVEYOR BELT
2	1	37210-0046	WELDMENT, CONVEYOR CENTER FRAME	27	1	35000-1531	SPACER, NYLON, FITS BETWEEN SPROCKET
3	1	37210-0116	WELDMENT, CONVEYOR IDLER FRAME	28	1	22011-0014	COLLAR, SPLIT LOCKING
5	4	35210-0429	PIVOT PLATE	29	2	22034-0003	BUSHING, BRONZE 3/4" O.D. x 5/8" I.D.
6	8	35210-0491	BUSHING, CONVEYOR ADJUSTMENT	30	2	35000-1080	SPACER, NYLON 1-1/4" O.D. x 3/4" I.D.
7	8	F716A8805	WASHER, EXTERNAL TOOTH 1/4"	31	2	54947	BRACKET, SHAFT SUPPORT
8	8	21176-0001	LOCKNUT, HEX 1/4"-20	32	1	35900-0023	BUSHING, SPLIT BELT DRIVE SPROCKET
9A	2	22450-0271	CONVEYOR BELT, COMPLETE, 15"W x 206"L (0.38 x 5.23m)	33	2	22152-0017	SPROCKET, DRIVE SHAFT, 5/8" BORE, 9T, WITH SET SCREW
9B	--	33900-0037	CONVEYOR BELT, 15"W x 12"L (0.38 x 0.30m)	34	1	42400-0164	ASSEMBLY, ROLLER CHAIN COMPLETE (62 LINKS)
10	2	51382	MASTERLINKS KIT, 15" (0.81m) BELT (INC. ITEMS 11-13)	35	1	42410-0128	ASSEMBLY, ROLLER CHAIN COMPLETE (48 LINKS)
14	1	42400-0354	SHAFT, IDLER, REAR, 32-3/4"	36	2	22273-0001	MASTERLINK, ROLLER CHAIN
15	1	21415-0001	FLAT WASHER, BRONZE, 1" O.D. X 1/2" I.D.	37	2	22152-0018	SPROCKET, DRIVE MOTOR, 5/8" BORE, 15T, WITH SET SCREW
16	1	35000-1535	SHAFT, IDLER, FRONT, 16-3/8"	38	1	35210-0640	ADAPTER, DRIVE MOTOR WITH SET SCREW
17	8	22229-0003	SPROCKET, CONVEYOR BELT	40	2	58678	DRIVE MOTOR, BRUSHLESS, 1/8 HP, 1400:1
19	2	22034-0003	BUSHING, BRONZE 3/4" O.D. x 5/8" I.D.	45	1	55027	END STOP, CONVEYOR, 29-1/4"
20	2	37000-0413	BRACKET, IDLER SHAFT ADJUSTMENT	46	1	55028	REAR STOP, CONVEYOR, 18"
21	2	35000-1008	SCREW, CONVEYOR TENSION ADJUSTMENT	47	2	30004	CRUMB PAN
22	2	54947	BRACKET, SHAFT SUPPORT	48	2	M10098	HARNES, WIRE
23	1	42400-0355	SHAFT, DRIVE, REAR, 35-1/3"	49	1	45035	MOUNTING BRACKET, DRIVE MOTOR
24	1	21415-0001	FLAT WASHER, BRONZE, 1" O.D. X 1/2" I.D.				
25	1	35000-1536	SHAFT, DRIVE, FRONT, 17-3/4"				

Standard Finger Configuration and Parts

F A B E X E B A F



C D X D C

Notes

SYMMETRICAL FINGER CONFIG.
 AVG CONTROL T/CS: 4 USED
 ENT: TOP INNER & OUTER LOCATIONS: 12" PROBES
 EXIT: TOP INNER & OUTER LOCATIONS: 12" PROBES
 RPM= 2100RPM, INVERTERS SET @ 63Hz AND ALL ENERGY SAVING MODES, LOW SPEED @ 40Hz
 BAKE TIME & TEMP: 4'30" @ 490°F + or - 10°F
 BOTH SIDES END PLUGS HAVE DIVERTERS
 OVEN DERATED TO 175,000 BTU/HR

- A = 45084 WLDMT, OTR PLT W/EXT TAB S/L4
 35000-1366 PLATE, INNER PERF L6 ALUZ
 45083 ASSY, RAISED MANF W/PERF BAFFEL
- B = 392251 WLDMT, PLT OTR S/L6 W/EXT TAB
 35000-1366 PLATE, INNER PERF L6 ALUZ
 45083 ASSY, RAISED MANF W/PERF BAFFEL
- C = 37900-0051 PLATE, OUTER S/L6
 35000-1366 PLATE, INNER PERF L6 ALUZ
 36449 WLDMT, MANF W/PERF BAFFLE ALUZ
- D = 55041 WLDMT, OUTER L18 W/12 ROWS
 35210-0520 PLATE, INNER PERF L18 ALUZ
 43034 ASSY, MANF W/PERF BAFFLE ALUZ
- E = 35210-0535 PLATE, BLANK PRTL 2.75 UPR
- F = 35210-0536 PLATE, FULL BLANK ALUZ
- G =

Rev.	Date	Description	By
E	2/23/2007	CHG'D DESC FROM 770M TO 770G ECN006363A	AJ
D	9/19/2006	CHANGED BAKE TEMP WAS 480-490 F ECN 006285	AJ
C	2/15/2006	CHANGED DESC FROM PS670M TO PS770M ECN006034	AJ
B	1/9/2006	RELEASE TO PROD RPM WAS 2000, Hz WAS 60 ECN 004386	AJ

Description

CNFIG, FNG PS770M PJS @2100RPM

P/N	Rev.
58762	E



REV	DATE	ECN	REVISION DESCRIPTION	BY	CHK	DATE
C	04/25/2006	004145	REARRANGED CUSTOMER HEADLINE	PC	NSS	05/05/2006
D	09/19/2006	004295	CHANGED TEMPERATURES	PC	NSS	09/19/2006
E	02/27/2007	004333	CHANGE TO BESE FROM 7700 TO 7706	AJ	NSS	02/27/2007

PS770G PAPA JOHN'S
LEFT-TO-RIGHT or RIGHT-TO-LEFT CONVEYOR

Low Altitude @ - 3000 ft
Bake time: 4 mins. 30 sec.
Temperature 490-500°F/254-27°C

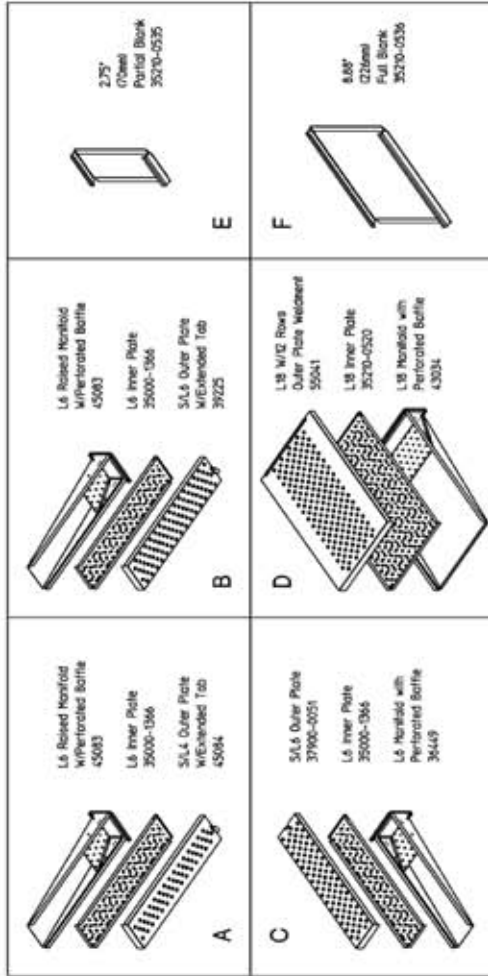
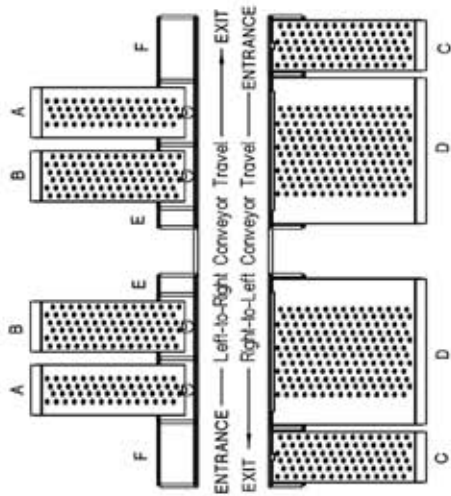

**Right to Left or Left to Right - No Change to Finger Configuration
RPM: 2100 (Inverters Set @ 63Hz)**

MATERIAL	SAUGE	TOLERANCE UNLESS SPECIFIED	THIS DRAWING IS CONFIDENTIAL AND PROPERTY OF
RYLAR		ANGLES ± 1.0°	THE MIDDLEBY CORPORATION 1400 Teestmaster Drive Eggen, Illinois 60120 847-741-3300
FINISH		DEC ± 0.05 IN ± 0.05 MM ± 0.05	
DRAWN	CHECKED	APPROVED	
AJ	MS	MS	
ALL DIMENSIONS ARE IN INCHES UNLESS OTHERWISE SPECIFIED. DO NOT SCALE DRAWING.			
PART NO			REV
58762-1			1 OF 1
LBL, FGR CNFG 770G P J ' S @ 2100RPM			E

THERMOCOUPLE PLACEMENTS 59077 REV G

PS770G PJ'S

NOTE: WIRE ALL TC2 PROBES TO TC2 TERMINAL

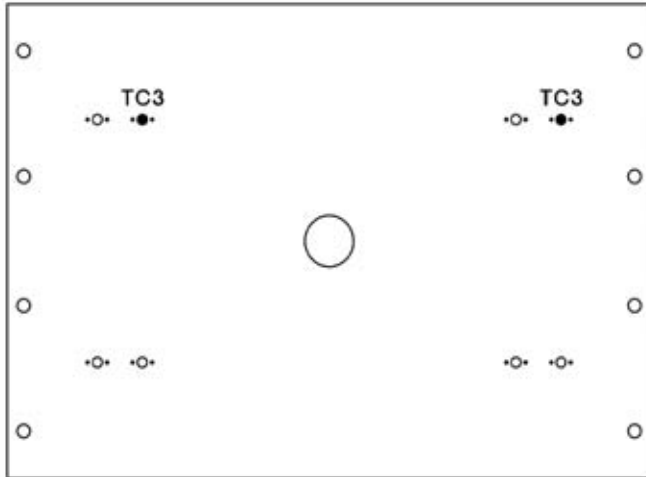

NOTE: WIRE ALL TC3 PROBES TO TC3 TERMINAL

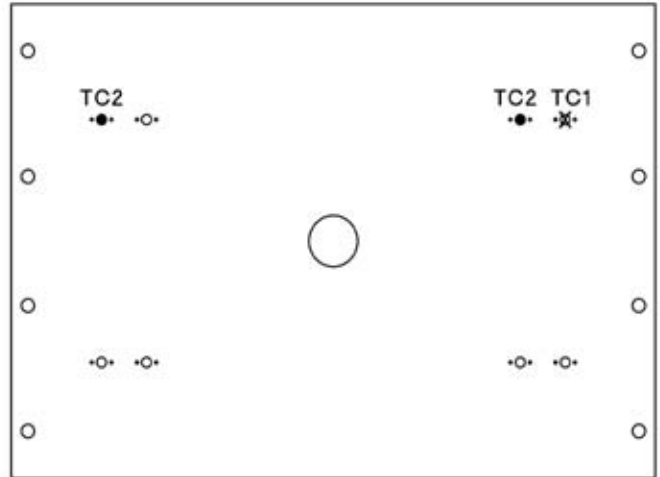

- (4) 12" CONTROL PROBES (P/N 33812-6)
- ✱ (1) 6" HIGH LIMIT PROBE (P/N 33812-1)

REAR VIEW

P/N: 59077 REV.

REV	DATE	ECN	REVISION DESCRIPTION	BY	CHK	DATE
D_	06/01/2006	006160	REVERSED POSITIONS FOR TC2 & TC3	FC	WSS	07/12/2006
E_	09/19/2006	006285	REVERSED POSITIONS OF TC2 & TC3	FC	WSS	09/19/2006
F_	02/23/2007	006363A	CHG'D DESC FROM 770M TO 770G	AJ	WSS	02/27/2007
G_			T/C Positions Shown for Either Conveyor Direction			

MATERIAL MYLAR	GAUGE:	TOLERANCE UNLESS SPECIFIED ANGLES ± 1.0° DEC .X ± .030 .XX ± .015 .XXX ± .005	THIS DRAWING IS CONFIDENTIAL AND PROPERTY OF THE MIDDLEBY CORPORATION 1400 Toastmaster Drive Elgin, Illinois 60120 847-741-3300
FINISH			
DRAWN AJ	CHECKED WSS	APPROVED WSS	
02/23/2007	02/27/2007	02/27/2007	
LBL, TC		PS770G PJ'S@2100RPM	
ALL DIMENSIONS ARE IN INCHES UNLESS OTHERWISE SPECIFIED. DO NOT SCALE DRAWING		PART NO 59077	SHT 1 OF 1 REV G_

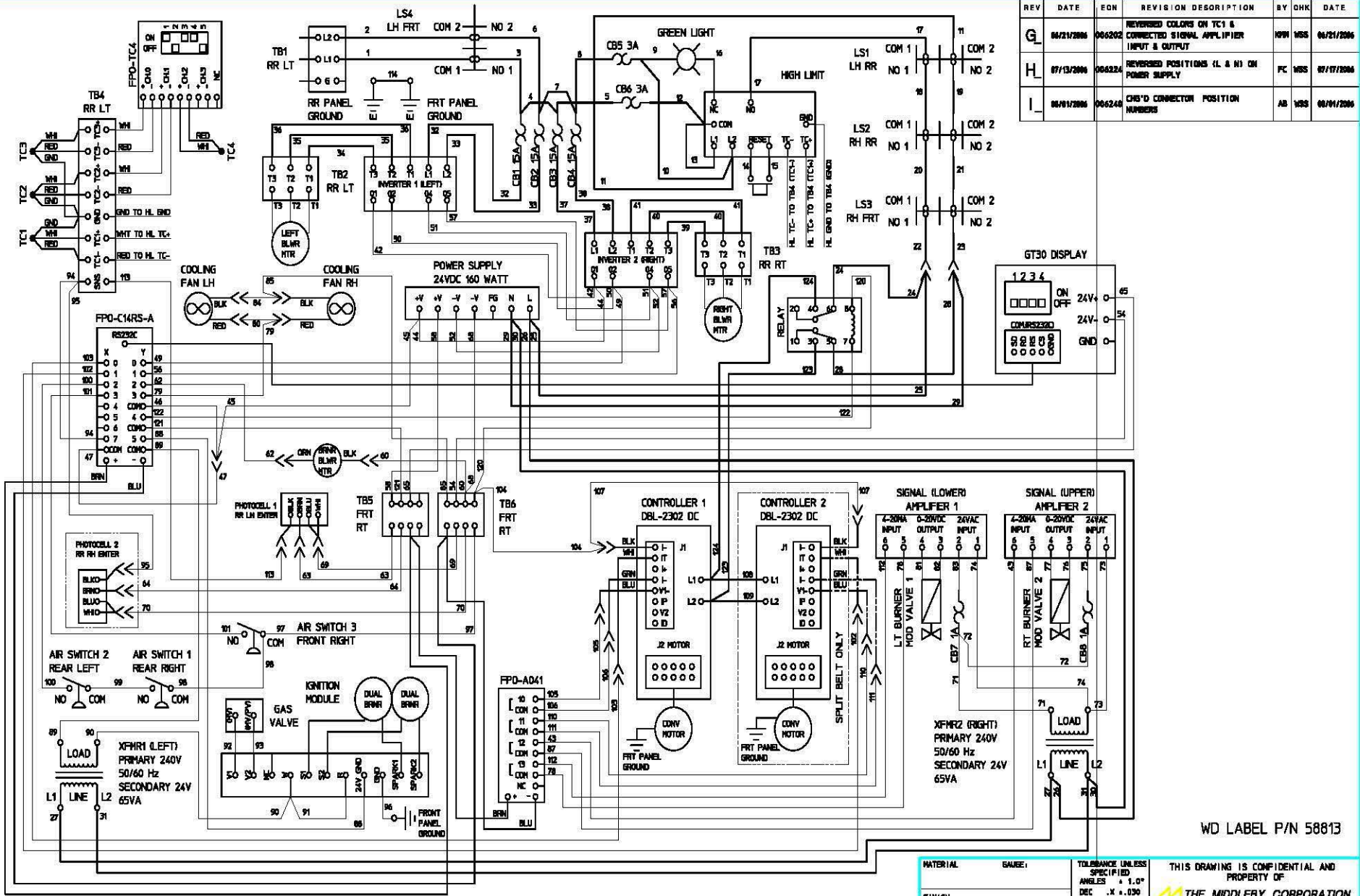

REV	DATE	EON	REVISION DESCRIPTION	BY	CHK	DATE
G	06/21/2006	066202	REVERSED COLORS ON TC1 & CONNECTED SIGNAL APPLIFIER INPUT & OUTPUT	HW	WSS	06/21/2006
H	07/13/2006	066224	REVERSED POSITIONS (L & R) ON POWER SUPPLY	PC	WSS	07/17/2006
I	06/01/2006	066244	CB'D CONNECTOR POSITION NUMBERS	AB	WSS	06/01/2006

WD LABEL P/N 58813

MATERIAL	Gauge:	TOLERANCE UNLESS SPECIFIED
FINISH		ANGLES ± 1.0°
		DEC .X ± .030
		.XX ± .015
		.XXX ± .005
DRAWN	CHECKED	APPROVED
AB	WSS	WSS
06/01/2006	06/01/2006	06/01/2006

THIS DRAWING IS CONFIDENTIAL AND PROPERTY OF
THE MIDDLEBY CORPORATION
 1400 Toastmaster Drive
 Elgin, Illinois 60120
 847-741-3300

WD, G208-240/50/60/1 PS870/770

ALL DIMENSIONS ARE IN INCHES UNLESS OTHERWISE SPECIFIED. DO NOT SCALE DRAWING	PART NO	SHT	REV
	54745	1 of 1	I

MIDDLEBY MARSHALL
PS 770 INITIAL START-UP / CHECK OUT PROCEDURES

After following the standard start-up form please complete this form and attach it to the start-up form.

1. _____ Photocell—assure that when breaking the photocell beam the LED on the back of the photocell is lit. If LED on back of photocell stays lit then it is out of adjustment (adjust accordingly). If LED never lights, adjust the gain located on the back of the photocell 1/8th of a turn counter clockwise then remount and aim. The photocell should trip with 2 pizza screens stacked on top of each other from the reflector back to the photo eye (all the way across the conveyor)
2. _____ Make sure the end plugs them selves are installed correctly and the air curtains are in the second hole from the top.
3. _____ Set the energy modes to:

OVEN WITH POS CABLE	OVEN WITHOUT POS CABLE
MODE 2--7:00 MINUTES	MODE 2--7:00 MINUTES
MODE 3--14:00 MINUTES	MODE 3--20:00 MINUTES
MODE 4--1 HOUR	MODE 4--1 HOUR
4. _____ Does the conveyor start within 5 degree's of set point? Both sides of the oven need to be within 5 degree's of set point temperature for conveyor to operate
5. _____ Flame color- if the flame is yellow at full flame, internal air shutter on each burner should be checked to confirm that they are set to 1/8".
6. _____ During heat up- both sides (right&left) should heat up within 30 degrees of each other, if not check thermocouple wiring to insure it is correct.
7. _____ verify micro-amps on the ignition module are greater then 2.0 you will read this on the fc1+and- and fc2+ and -. If not adjust air shutter and bypass on modulating valves.
8. _____ verify the low flame bypass is set correctly; there are 2 ways of doing this. First option is to go into the maintenance screen using the password NOHRA and turn the burner on low flame. The other is stated in step 9 below (either method is acceptable)
9. Bypass (low flame) setting—in mode 2 , both burners should stay lit. This can be tested by passing your hand over the reflector, and assuring the temp rises. If not increase bypass rate (located on the side of the modulating valve under the blue cap) to correct. Natural gas ¼ turn from off-propane 1/3 turn from off.
10. _____ In mode 1 the temperature should not continually rise above set point on either side. If it does lower bypass.

Serial number _____

Customer order number _____

Signature _____ date _____

NOTE: ATTACH This PS770 Initial Start-Up/Check Out Procedures Completely Filled Out Along With The Completely Filled Out Startup Checklist Pages 1 And 2 (Form #P/N 37201 • Rev. F • V1 • 7/05)

