

# Parts Manual

with Wiring Diagrams  
for domestic ovens

Starting Serial # 982150606

Serial # Code (Nine Digit Code)  
(for units produced prior to mid-July, 2006)  
First 4 digits - order of production  
Fifth digit - model specific  
Sixth and Seventh digit - month of production  
Eighth and Ninth digit - year of production

Serial # Code (Ten Digit Code)  
(for units produced after to mid-July, 2006)  
First 5 digits - order of production  
Sixth digit - model specific  
Seventh and Eighth digit- month of production  
Ninth and Tenth digit - year of production

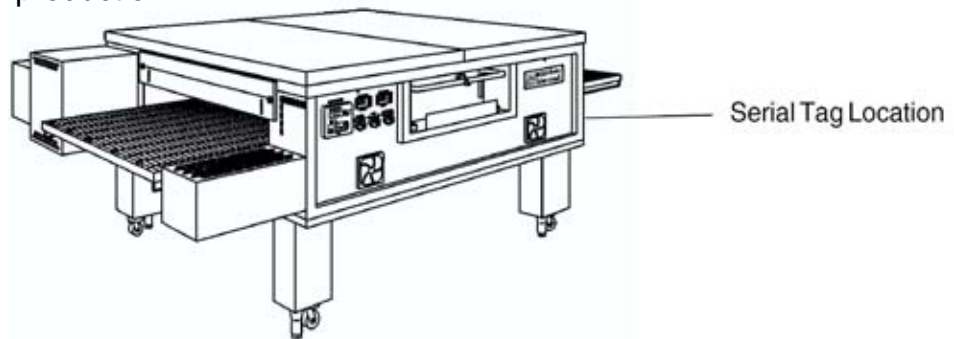

## Table of Contents: Page 2



www.middleby.com  
email: techsupport@middleby.com  
1400 Toastmaster Drive  
Elgin, IL 60120  
1-847-741-3300 fax 1-847-741- 4406

# Table of Contents

Spec Sheet .....	3
Key Parts .....	6
Cross Reference of Wiring Diagram Symbols and Part Number(s) .....	7
View of Installation Kit(s) and Base Kit(s) .....	8
Parts for Installation Kit(s) and Base Kit(s) .....	9
View of Oven Panels, End Plugs and Window .....	10
Parts for Oven Panels, End Plugs and Window .....	11
View of Gas Piping .....	12
Parts for Gas Piping .....	13
View(s) of Burner/Blower Motor Assembly .....	14
Parts for Burner/Blower Motor Assembly .....	15
View(s) of Front Control Area(s) .....	16
Parts for Front Control Area(s) .....	17
View of Rear Compartment and Blowers (Conveyor Drive End Shown) .....	18
Parts for Rear Compartment and Blowers (Conveyor Drive End Shown) .....	19
View of “Single” Belt Conveyor .....	20
Parts for “Single” Belt Conveyor .....	21
View of “Split” 50/50 15” Wide Belt Conveyor .....	22
Parts for “Split” 50/50 15” Wide Belt Conveyor .....	23
View of “Split” 40/60 Belt Conveyor (12”/18”) .....	24
Parts for “Split” 40/60 Belt Conveyor (12”/18”) .....	25
Standard Finger Configuration 59730D and Part Numbers .....	26
Finger Label -59730-1 .....	27
Thermocouple Placements L-R (Shipped Standard) 59072G.....	28
Thermocouple Placements R-L (Converted to Right to Left in Field) 59073G .....	29
Wiring Diagram, G208-240, 50/60Hz, 1 Phase 54745 Rev. I .....	30



PATENTS PENDING

**Principle**

Middleby Marshall PS Series Conveyor ovens bake both faster and at a lower temperature than other ovens. Patented vertical columns of hot air move heat aerodynamically instead of using high temperatures. The streams of hot air remove the boundary layers of cool heavy air which tend to insulate the product. This gives very rapid baking without burning. All PS870WOW ovens are designed to cook pizza at 5:45 to 6:45 minutes belt speed.

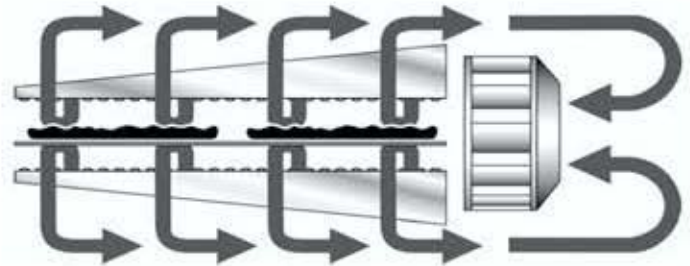

**Standard Features**

- **Impingement PLUS!** low oven profile and dual air return
- **Patented EMS Energy Management System** reduces gas consumption and increases cooking efficiency
- 70"/1778mm-long cooking chamber
- 32"/813mm-wide, 106"/2692mm-long conveyor belt

**Energy Management System**

The PS870 features an Energy Management System (EMS) that automatically reduces gas consumption. Touch Screen Control can be programmed in one energy saving mode.

**Cleanability**

PS870 ovens are designed for easy cleaning. Removable parts include: crumb pans, end panels, air fingers, and a folding conveyor belt assembly.

**Easily Serviced**

Control compartment is designed for quick and easy access. All electrical controls are door-mounted.

**Warranty**

All PS870 models have a one year parts and labor warranty. Oven start-up and demonstration are included at no additional charge (USA only).

**Ventilation**

For installation under a ventilation hood only.

## PS870-2 Double Oven with 15" (381mm) leg extensions

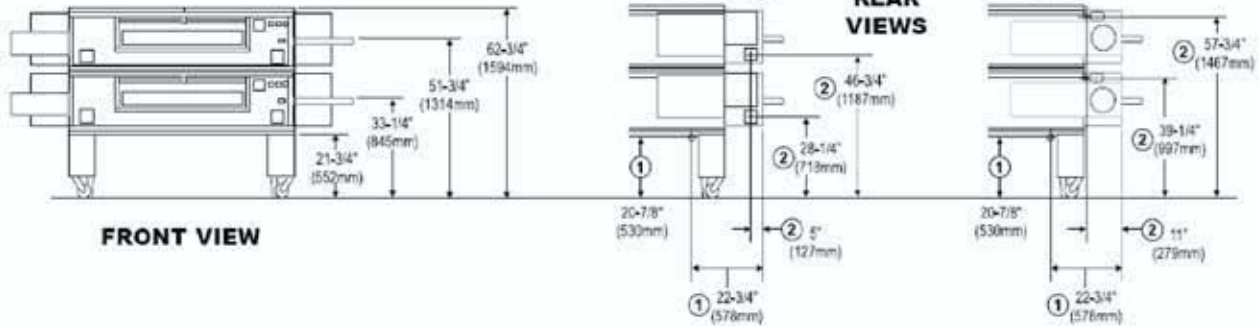

## PS870-3 Triple Oven with 4" (102mm) leg extensions

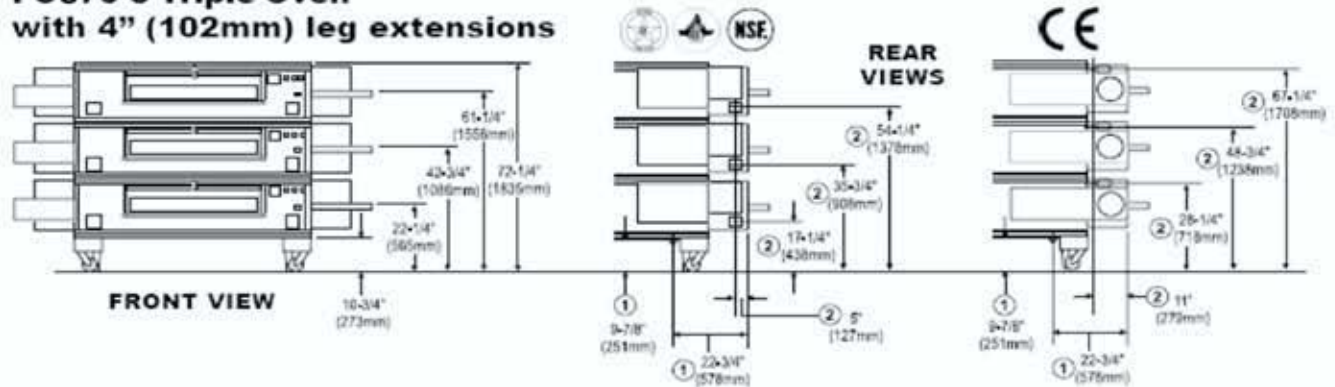



**RECOMMENDED MINIMUM CLEARANCES**

Rear of oven to wall	Right side of oven to wall	Left side of oven to wall
0" (0mm)	0" (0mm)	0" (0mm)

**GENERAL INFORMATION**

Model	Heating Zone	Baking Area	Belt Length	Belt Width	Oven Depth	Height	Max. Operating Temp.	Bake Time Range	Ship Wt.	Ship Cube
PS870-1 with 19" (483mm) leg extensions	70" 1778mm	15.5 sq. ft. 1.44m <sup>2</sup>	106" 2692mm	32" 813mm	61-3/4" 1568mm	48-1/4" 1226mm	550°F 288°C	5:45 6:45	1750 lbs. 795kg	160 ft. <sup>3</sup> 4.5m <sup>3</sup>
PS870-2 with 15" (381mm) leg extensions	140" 3556mm	31 sq. ft. 2.88m <sup>2</sup>	106" 2692mm	32" 813mm	61-3/4" 1568mm	62-3/4" 1594mm	550°F 288°C	5:45 6:45	3500 lbs. 1589kg	320 ft. <sup>3</sup> 9.0m <sup>3</sup>
PS870-3 with 4" (102mm) leg extensions	210" 5334mm	46.5 sq. ft. 4.32m <sup>2</sup>	106" 2692mm	32" 813mm	61-3/4" 1568mm	72-1/4" 1835mm	550°F 288°C	5:45 6:45	5250 lbs. 2384kg	480 ft. <sup>3</sup> 13.5m <sup>3</sup>

**ELECTRICAL SPECIFICATIONS**

Model	Version	Voltage	Phase/Freq.	Supply
PS870	 	208-240V	1/60 Hz	3 pole, 3 wire (2 hot, 1 grd)

*The average current draw during operation is significantly lower.*

**Max Current Draw at Startup**

Amps
20A*

**Breakers**

As per  
local codes

**GAS SUPPLY SPECIFICATIONS**

	Min. Gas Pipe Size	Supply Gas Pressure	Rated Heat Input
Natural Gas	2" (50.8mm) main One 1-1/4" (12.7mm) NPT branch to lower oven cavity with individual full-flow shutoff valve	6-12" W.C. (14.9-29.9 mbar)	175,000 BTU (44.1 kcal, 51.3 kW/hr.) per oven cavity
Propane Gas	2" (50.8mm) main One 1-1/4" (12.7mm) NPT branch to lower oven cavity with individual full-flow shutoff valve	11-14" W.C. (27.4-34.9 mbar)	175,000 BTU (44.1 kcal, 51.3 kW/hr.) per oven cavity

\* The gas supply pressures shown are for ovens installed in North America. The required gas supply pressures of other locations are dependent on the local gas type and on all applicable local codes.

**ALL SPECIFICATIONS SUBJECT TO CHANGE WITHOUT NOTICE.**

# KEY PARTS

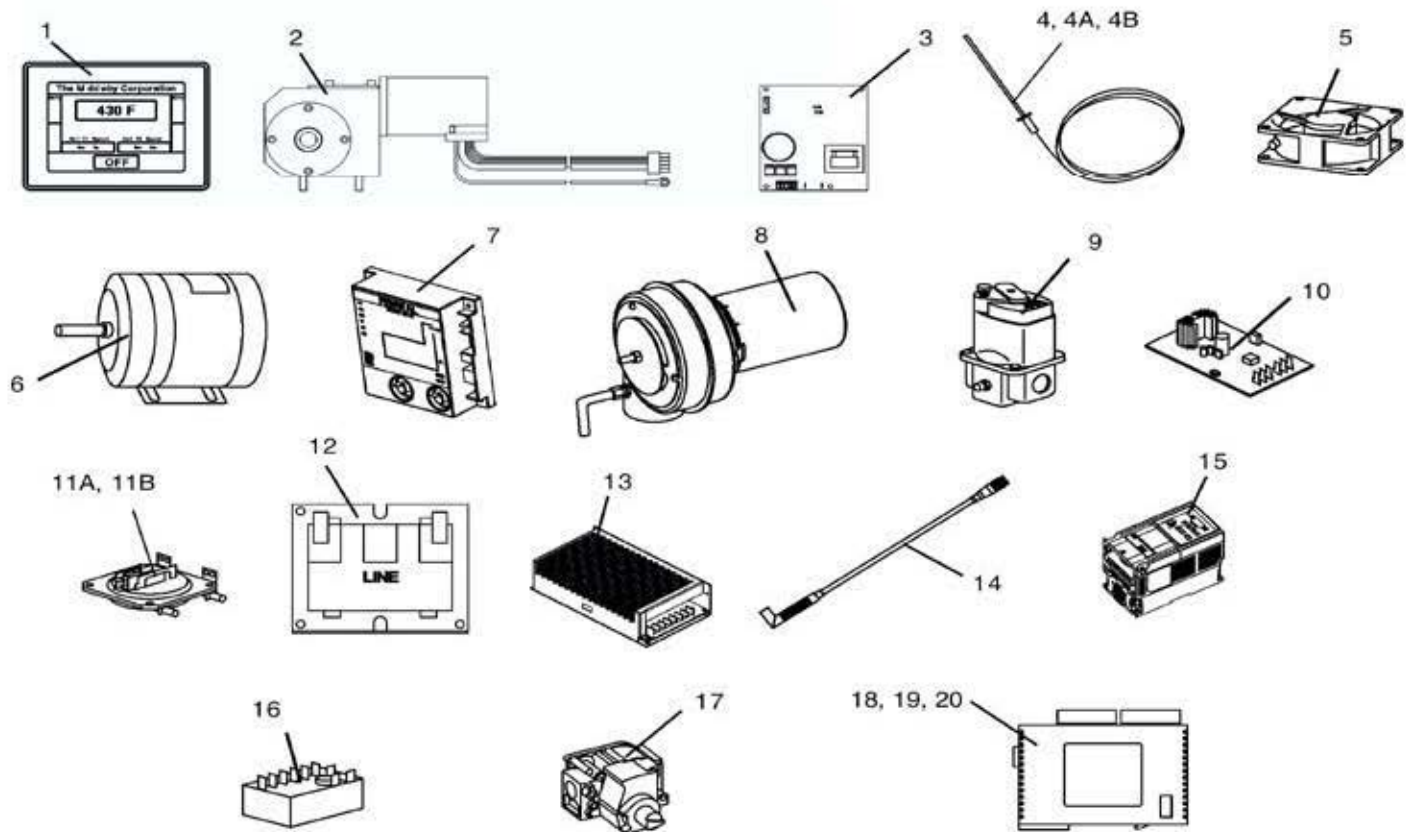

ITEM	PART NO.	DESCRIPTION	QUANTI
1	59081	Display, Touch Screen- Programmed	1
2	58678	Drive Motor, Conveyor, 1400:1, 130VDC	1 or 2
3	58679	Controller, Conveyor	1 or 2
4	33812-7	Thermocouple, 9-1/2" Temp. Control	5
4A	33812-8	Thermocouple, 2.5" Control Compartment	1
4B	33812-1	Thermocouple, 6" High Limit (33984)	1
5	M9616	Cooling Fan, 6", 24VDC	2
6	57288	Blower Motor, 2 hp, 1725 RPM	2
7	54727	Ignition Module, Dual	1
8	M9887	Burner/Blower Motor, 24VDC	1
9	59450	Modulating Gas Valve, 1/2"(41647)	2
10	31651	Amplifier Board	2
11A	50610	Air Switch, Rear Blower	2
11B	57141	Air Switch, Burner/Blower Motor, Front	1
12	32108	Transformer, 240V/24V, 65VA	2
13	M9608	Power Supply, 24VDC	1
14	59112	Photocell	1
15	59168	Inverter, 2 hp-Programmed	2
16	33983	Hi Limit Control Module	1
17	54724	Gas Valve, Main, 1/2" Natural Gas	1
18	59109	Control Module, Digital, C14RS, Left	1
19	58668	Thermocouple Module, Digital, TC4, Middle	1
20	58669	Convertor Module, Digital, A041, Right	1
21	58833	Flame Sensor	2
22	58834	Ignitor	2
23	58676	Control Cable-Touch Screen Display to PLC	1
24	59132	Relay-Glass	1
25	58777	Blower Belt	2

## CROSS REFERENCE of WIRING DIAGRAM SYMBOLS and PART NUMBERS

• Air Switch 1 -Rear Right .....	50610	• Ignition Module, Dual .....	54727
• Air Switch 2 - Rear Left.....	50610	• Inverter - 1 Left, 2HP .....	59168
• Air Switch 3 - Front Right.....	57141	• Inverter - 2 Right, 2HP .....	59168
• Blower Motor–Left .....	57288	• Switch(es)	
• Blower Motor–Right .....	57288	• LS1 (LH RR), Momentary .....	28021-0061
• Burner Blower Motor .....	M9887	• LS2 (RH RR), Momentary .....	28021-0061
• Circuit Breakers		• LS3 (RH Front), Inter Lock .....	28021-0047
• CB1 - 15A .....	45037	• LS4 (LH Front), Inter Lock .....	28021-0047
• CB2 - 15A .....	45037	• Reset Button .....	35145
• CB3 - 15A .....	45037	• Mod Valve 1(41647).....	59450
• CB4 - 15A .....	45037	• Mod Valve 2 (41647) .....	59450
• CB5 - 3A .....	45036	• Photocell 1 Entrance .....	59112
• CB6 - 3A .....	45036	• Photocell 2 Exit .....	59112
• CB7 - 1A .....	45644	• Power Supply .....	M9608
• CB8 - 1A .....	45644	• Relay .....	59132
• Cooling Fan LH .....	M9616	• Signal Amplifier 1 .....	31651
• Cooling Fan RH .....	M9616	• Signal Amplifier 2 .....	31651
• Controller 1 DC .....	58679	• TB1 RR LT (3 Pole) .....	44390
• Controller 1 DC (split belt) .....	58679	• TB2 RR LT (3 Pole) .....	44390
• Conveyor Motor .....	58678	• TB3 RR RT (3 Pole) .....	44390
• Conveyor Motor (split belt) .....	58678	• TB4 RR LT (8 Pole) .....	31047
• Dual Burner .....	54719	• TB5 Comp Brkt (4 Pole) .....	M0593
• Converter Module - Digital A041, Right .....	58669	• TB6 Comp Brkt (4 Pole) .....	M0593
• Control Module - Digital C14RS-A, Left .....	59109	• TC1 - 6" High Limit (33984) .....	33812-1
• Thermocouple Module - Digital TC4, Middle .....	58668	• TC2 - 9-1/2", Oven Temp. ....	33812-7
• Gas Valve .....	54724	• TC3 - 9-1/2", Oven Temp. ....	33812-7
• Green Light (Reset Button) .....	35145	• TC4 - 2.5", Control Compartment .....	33812-8
• GT30 Display .....	59081	• XFMR1 - 240V/24V 65 VA .....	32108
• High Limit .....	33983	• XFMR2 - 240V/24V 65 VA .....	32108

Wiring Diagram on Page 30.

Settings: Bake Time 6:30 @ 440°F High Blower Speed 2415 RPM @ 74 Hz. Low Blower Speed 40Hz.

**View of INSTALLATION KIT (Part Number 59057)**

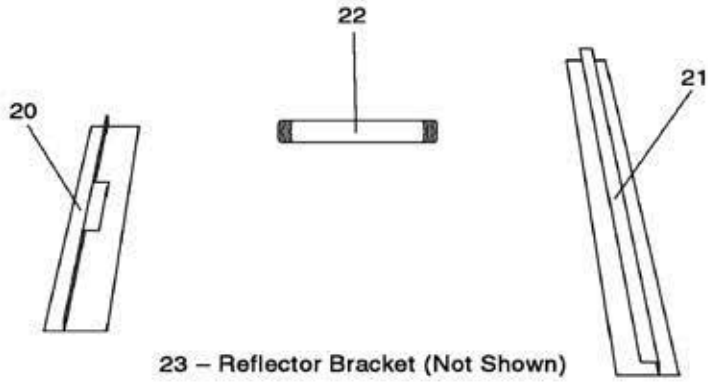

---

**View of BASE PAD KIT**

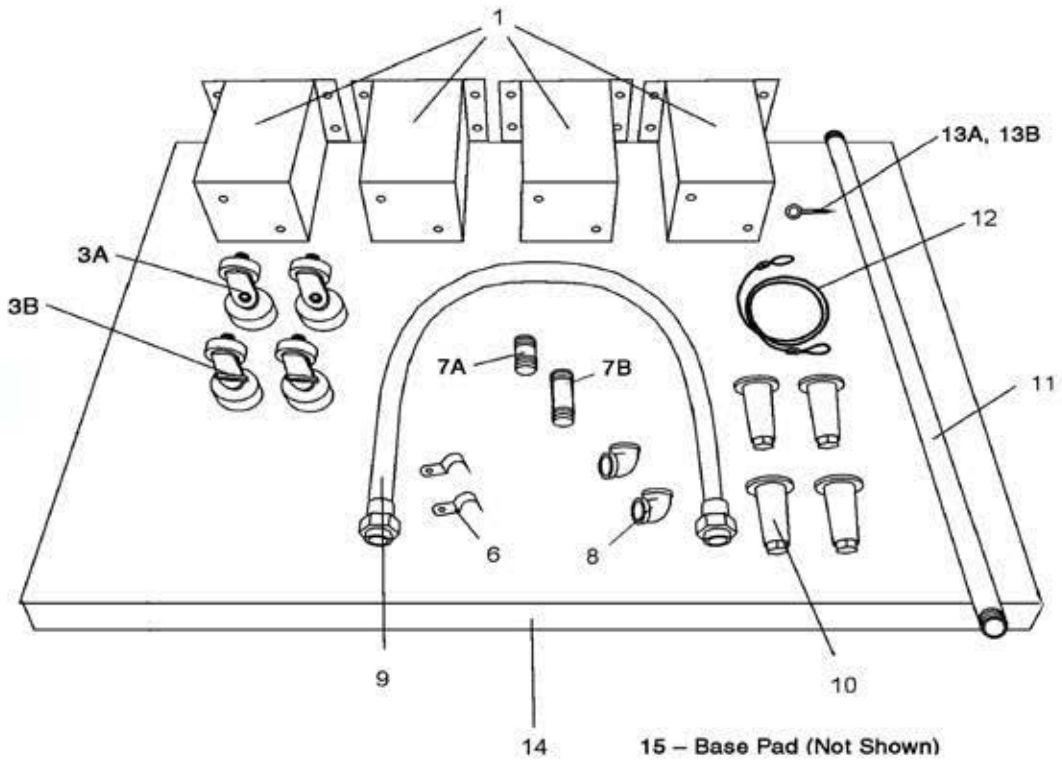

**Parts for INSTALLATION KIT (Part Number 59057)**

ITEM	QTY. - SGL. BELT	P/N	DESCRIPTION
20	1	55028	CONVEYOR REAR STOP, 18"
21	1	55027	CONVEYOR END STOP, 29-1/4"
22A	1	33120-0053	GAS PIPE NIPPLE, 1-1/4" X 9-1/2"
22B	2	59910	GAS PIPE NIPPLE, 1-1/4" X 4"
23	1	59419	BRACKET, REFLECTOR, R.H.

ITEM	QTY. SGL OVEN 19" LEGS 49026-0009	QTY. SGL/DBL OVEN/W 15" LEGS 49026-0011	QTY. TRIPLE OVEN 49026-0012	P/N	DESCRIPTION
1A	4	—	—	37210-0060	LEG, 19" (483mm) (OPTIONAL)
1C	—	4	—	37210-0057	LEG, 15" (381mm)
1D	—	—	4	39684	LEG, 4" (102mm) (43158, set of 4)
3A	2	2	2	37115-0102	CASTER, SWIVEL WITH 3/4" STUD
3B	2	2	2	58930	CASTER, SWIVEL WITH BRAKE
6	2	2	2	27271-0004	PIPE CLAMP, 1-1/2"
7A	2	2	2	33120-0055	NIPPLE, 1-1/4" DIA. X 3" L, NPT
7B	1	1	1	33120-0054	PIPE, 1-1/4" DIA. X 6" L
7C	2	2	2	59910	GAS PIPE 1-1/4" X 4"
8	2	2	2	23122-0007	ELBOW, 90°, 1-1/4" DIA.
9	1	1	1	22361-0003	GAS HOSE, 1-1/4" DIA. x 72" L
10	4	4	4	22450-0028	LEG, 6" (152mm) ADJUSTABLE WITH 3/4" STUD
11	1	1	1	33120-0056	GAS PIPE, 1-1/4" DIA. x 54" L
12	1	1	1	22450-0253	RESTRAINT CABLE, 60" (1524mm)
13A	1	1	1	21392-0005	EYE BOLT, WALL
13B	1	1	1	37699	EYE BOLT, BASE PAD
14	2	2	2	35210-0656	TOP COVER (RIGHT OR LEFT)

**NOT SHOWN:**

15	1	1	1	37210-0055	BASE PAD
16	2	2	2	21292-0001	SCREW, TEKS HWH #2PT #10-16 x 3/4"
17	16	16	—	21216-0018	BOLT, HEX CAP 1/2"-13 x 1-1/4"
18	16	16	—	21416-0003	FLAT WASHER, 1/2"
19	16	16	—	21426-0004	LOCK WASHER, 1/2"
20	8	8	8	59156	SCREW, TOP COVER, 1-1/2" LONG

**View of PANELS, END PLUGS and WINDOW**

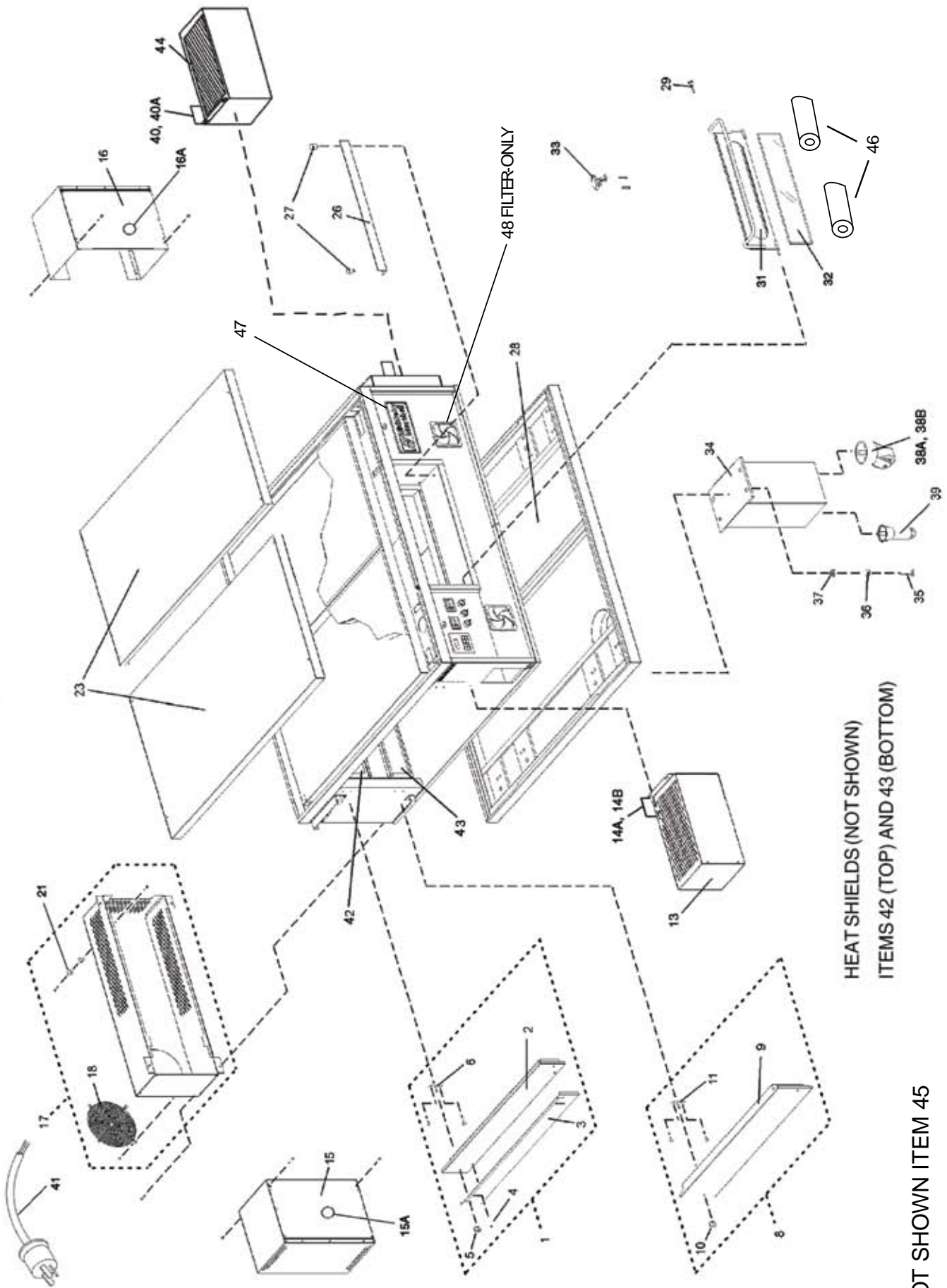

HEAT SHIELDS (NOT SHOWN)  
ITEMS 42 (TOP) AND 43 (BOTTOM)

NOT SHOWN ITEM 45

EARLIER MODELS REQUIRED A RIGHT TO LEFT KIT TO CONVERT TO LEFT OPERATION PART #59340

**Parts for PANELS, END PLUGS and WINDOW**

ITEM QTY.	P/N	DESCRIPTION	ITEM QTY.	P/N	DESCRIPTION
1	39539	ASSY, UPPER END PLUG (INC. ITEMS 2-6)	28	37210-0055	BASE PAD
2	41778	WELDMENT, UPPER END PLUG	29	34121-0003	SCREW, WINDOW PIVOT
3	50834	EYEBROW	31	45012	ASSEMBLY, WINDOW/LATCH (INC. ITEM 32 & 33)
4	220295	SCREW, "AB" HEX WSHR HD #10 X 3/4"	32	41597	GLASS, WINDOW, PRE-CUT, 3-1/2" X 20"
5	36452	WING NUT, 1/4"-20 W/PLASTIC GRIP	33	45087	LATCH
6	41708	PLATE, END PLUG MOUNTING	34A	37210-0060	LEG, 19"
8	39569	ASSY, LOWER END PLUG (INC. ITEMS 9-11)	34B	37210-0057	LEG, 15"
9	41779	WELDMENT, LOWER END PLUG PS500	34C	39684	LEG, 4"
10	36452	WING NUT, 1/4"-20 W/PLASTIC GRIP	35	21216-0018	BOLT, HEX CAP 1/2"-13 X 1-1/4" - SINGLE & DOUBLE OVENS
11	41708	PLATE, END PLUG MOUNTING	36	21426-0004	LOCKWASHER, 1/2" - SGL & DBL OVENS
13	57501	ASSEMBLY, DRIVE MOTOR SHROUD	37	21416-0003	FLAT WASHER, 1/2" - SGL & DBL OVENS
14A	59098	BRACKET FOR REFLECTOR	38A	37115-0102	CASTER, SWIVEL WITH 3/4" STUD - SINGLE, DOUBLE, & TRIPLE OVENS
14B	59099	REFLECTOR	38B	58930	CASTER, SWIVEL WITH BRAKE
15	57286	ASSEMBLY, LEFT MOTOR SHROUD	39	22450-0028	LEG, 6" (152mm) ADJUSTABLE WITH 3/4" STUD - SINGLE, DOUBLE, & TRIPLE OVENS
15A	58758	GLASS, 2" x 2" x 0.25"	40	59098	BRACKET, REFLECTOR, RIGHT HAND
16	57293	ASSEMBLY, RIGHT MOTOR SHROUD	40A	59099	REFLECTOR
16A	58758	GLASS, 2" x 2" x 0.25"	41	49975	CORD & PLUG, L6-20P
17	54715	ASSEMBLY, REAR SHROUD (INC. ITEM 18 & 19)	42	59148	HEAT SHIELD, TOP
18	31765	GRILL, COOLING FAN	43	59149	HEAT SHIELD, BOTTOM
21	48522	SPACER	44	59226	ASSEMBLY, SHROUD, RIGHT HAND
23	35210-0656	TOP COVER	45	59340	RIGHT TO LEFT DIRECTION KIT-EARLY MODELS PRODUCED BEFORE 09/06
26	42488	WINDOW GUARD	46	59562	COOL HANDLE INSULATOR
27	30927	BUMPER, WINDOW	47	58764	MIDDLEBY LOGO
			48	310-2468	FILTER ONLY
			49	59568	Partition Kit
			50	59455	Top Panel Partition 6" x 5.13" x 37"
			51	59464	Bottom Panel-L-Shaped 2" x 4.13" x 33.36"

# View of GAS PIPING

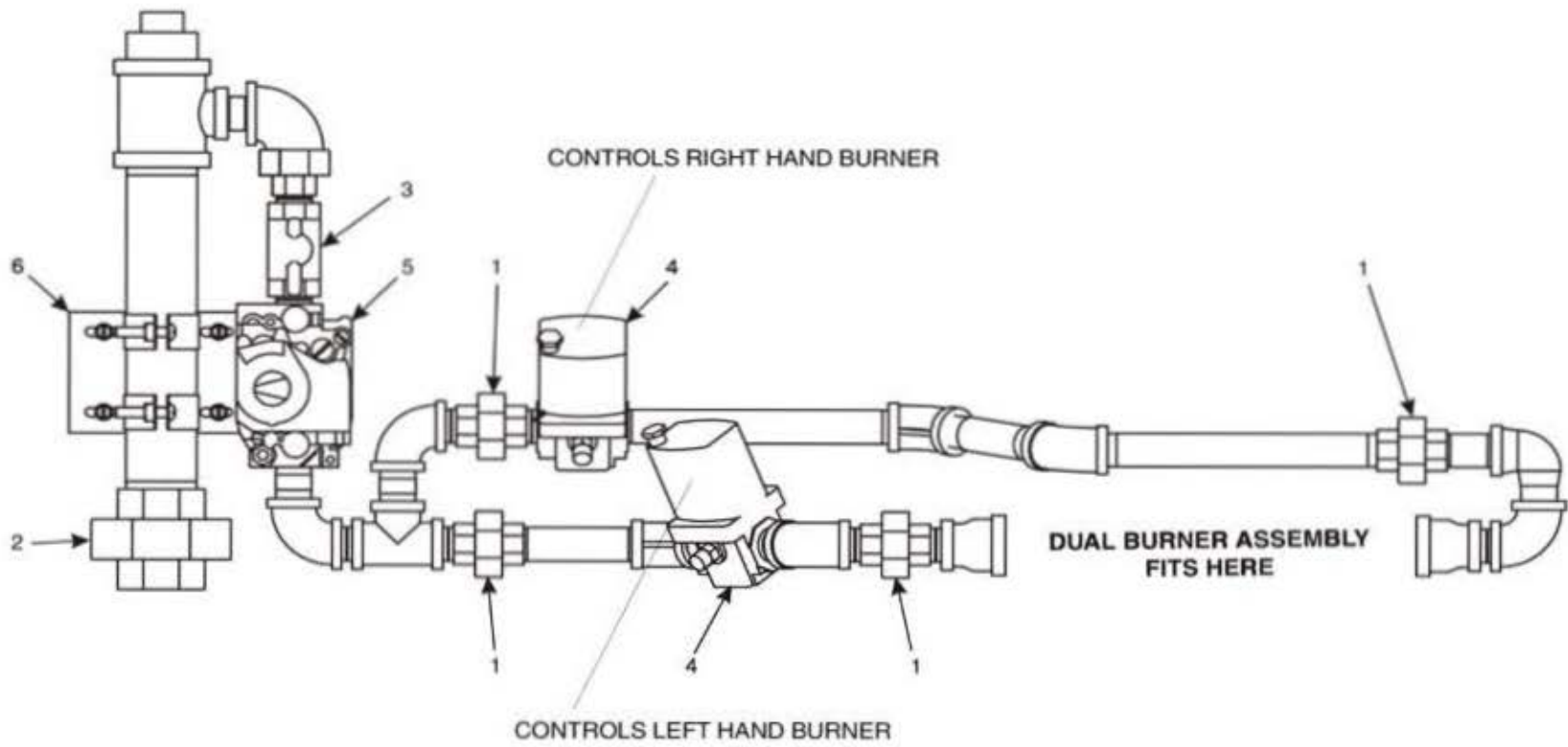

## Parts for GAS PIPING

ITEM	QTY.	P/N	DESCRIPTION
1	4	23051-0003	UNION, 1/2"
2	1	23051-0012	UNION, 1-1/4"
3	1	23115-0009	MANUAL ON/OFF GAS VALVE, 1/2", BALL
4	2	59450	MODULATING GAS VALVE, 1/2" (41647)
5	1	54724	VALVE, COMBINATION, 1/2" -NATURAL GAS
5A	1	28092-0018	SPRING FOR LP CONVERSION
6	1	42410-0016	BRACKET/CLAMP

**View of BURNER/BLOWER MOTOR ASSEMBLY**

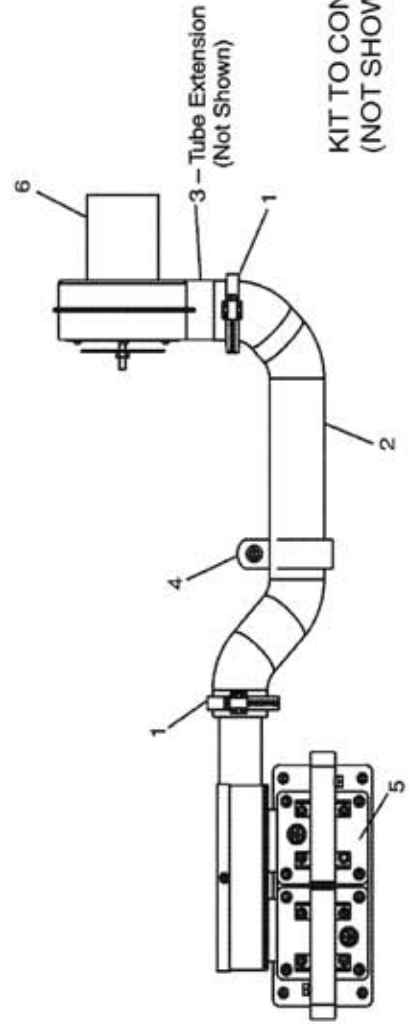
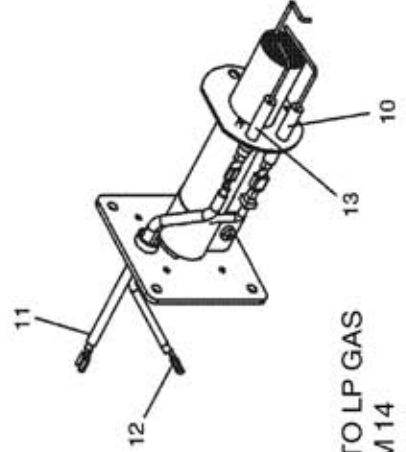
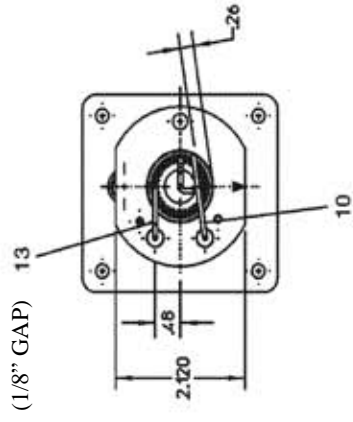
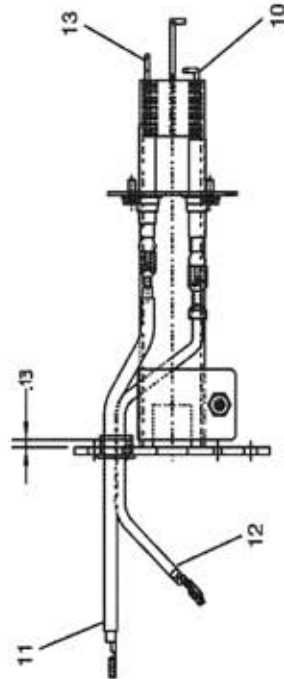
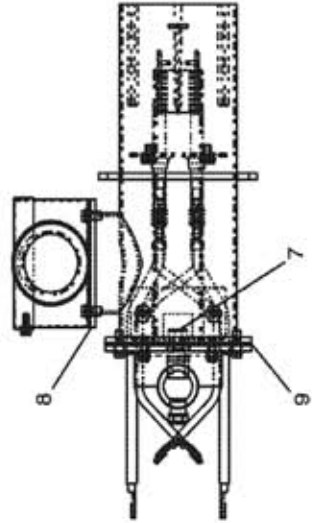
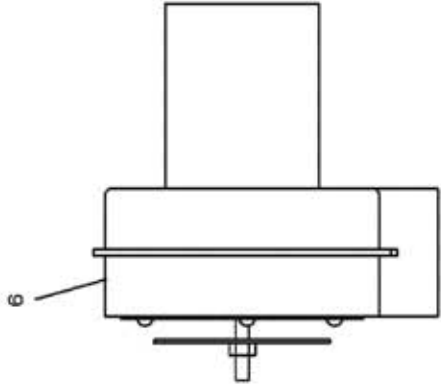
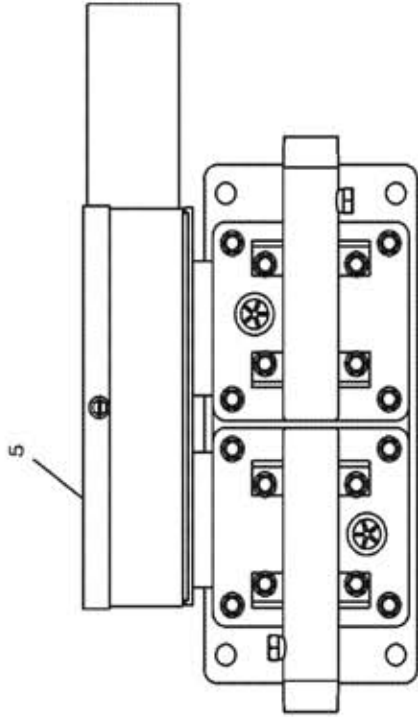
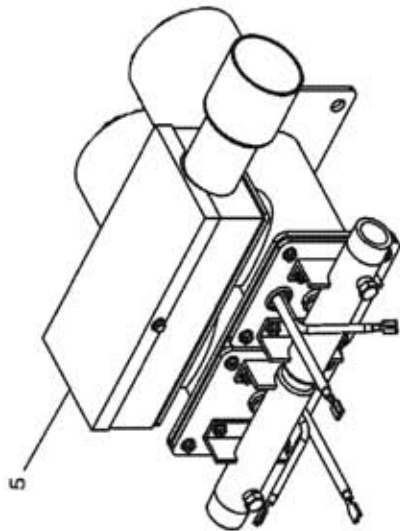

KIT TO CONVERT TO LP GAS  
(NOT SHOWN) ITEM 14

## Parts for BURNER/BLOWER MOTOR ASSEMBLY

ITEM	QTY.	P/N	DESCRIPTION
1	2	22450-0259	CLAMP, DUCT
2	1	22450-0255	DUCT
3	1	35210-0053	TUBE EXTENSION <i>(Not Shown)</i>
4	1	58754	CLAMP
5	1	54719	DUAL ASSEMBLY BURNER <i>(As of 5/1/07 - Targets are Positioned Inside Burner Tubes)</i>
6	1	M9887	BURNER/BLOWER MOTOR, 24V DC
7	2	Contact Factory	ORIFICE, NATURAL GAS, .173, #17
8	1	Contact Factory	GASKET, AIR INTAKE
9	1	Contact Factory	GASKET, DUAL VERTURE
10	2	58833	ELECTRODE, FLAME SENSOR
11	2	58836	WIRE, IGNITION, 27" LONG, 5mm
12	2	58835	WIRE, FLAME SENSOR, 36" LONG
13	2	58834	IGNITOR, ELECTRODE-1/8" GAP
14	1	Contact Factory	KIT TO CONVERT TO LP
14A	2	59074	ORIFICE, LP. 118
14B	1	28092-0018	SPRING FOR GAS VALVE
15	1	Contact Factory	KIT TO CONVERT TO NAT GAS

View(s) of FRONT CONTROL AREA(S)

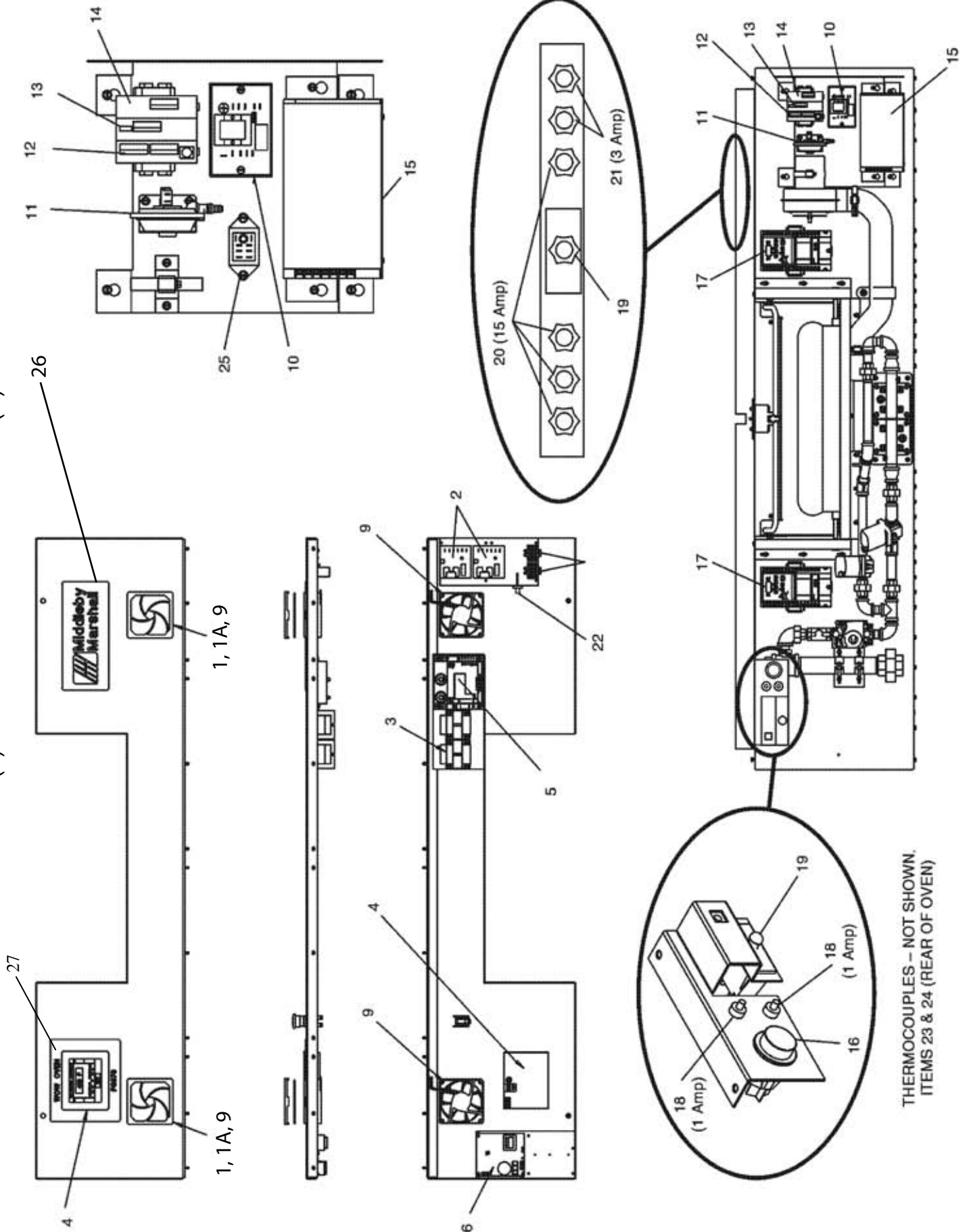

**Parts for FRONT CONTROL AREA(s)**

<b>ITEM</b>	<b>QTY.</b>	<b>P/N</b>	<b>DESCRIPTION</b>
1	2	310-2458	FILTER/GUARD, FAN
1A	2	310-2468	FILTER ONLY
2	2	31651	AMPLIFIER BOARD
3	2	32108	TRANSFORMER, 240/24V, 65VA
4	1	59081	TOUCH SCREEN DISPLAY
5	1	54727	DUAL IGNITION MODULE
6	1or 2	58679	CONTROLLER, CONVEYOR
8	2	M0593	TERMINAL BLOCK, 2-POLE
9	2	M9616	COOLING FAN, 24VDC
10	1	33983	HI-LIMIT CONTROL
11	1	57141	AIR SWITCH, FRONT, BURNER/BLOWER
12	1	59109	CONTROL, (LEFT-HAND), DIGITAL, C14RS -PROGRAMMED
13	1	58668	THERMOCOUPLE (MIDDLE), CONTROL, TC4
14	1	58669	CONVERTER, (RIGHT-HAND), A041
15	1	M9608	POWER SUPPLY, 24VDC
16	1	35145	RESET SWITCH W/GREEN LIGHT, HI-LIMIT
17	2	59168	INVERTOR -PROGRAMMED
18	2	45644	CIRCUIT BREAKER, 1 AMP
19	2	28021-0047	SWITCH, INTERLOCK
20	4	45037	CIRCUIT BREAKER, 15 AMP
21	2	45036	CIRCUIT BREAKER, 3 AMP
22	1	33812-8	THERMOCOUPLE, 2.5" x 60", CONTROL COMPARTMENT
23	5	33812-7	THERMOCOUPLE, 9-1/2" x 120", REAR OF OVEN
24	1	33812-1	THERMOCOUPLE 6" (HIGH LIMIT) REAR OF OVEN (33984)
25	1	59132	RELAY, DPDT, 24VDC COIL
26	1	58764	MIDDLEBY LOGO
27	1	59085	LABLE - MIDDLEBY MARSHALL WOW OVEN

**View(s) of REAR COMPARTMENT AND BLOWER (CONVEYOR DRIVE END SHOWN)**

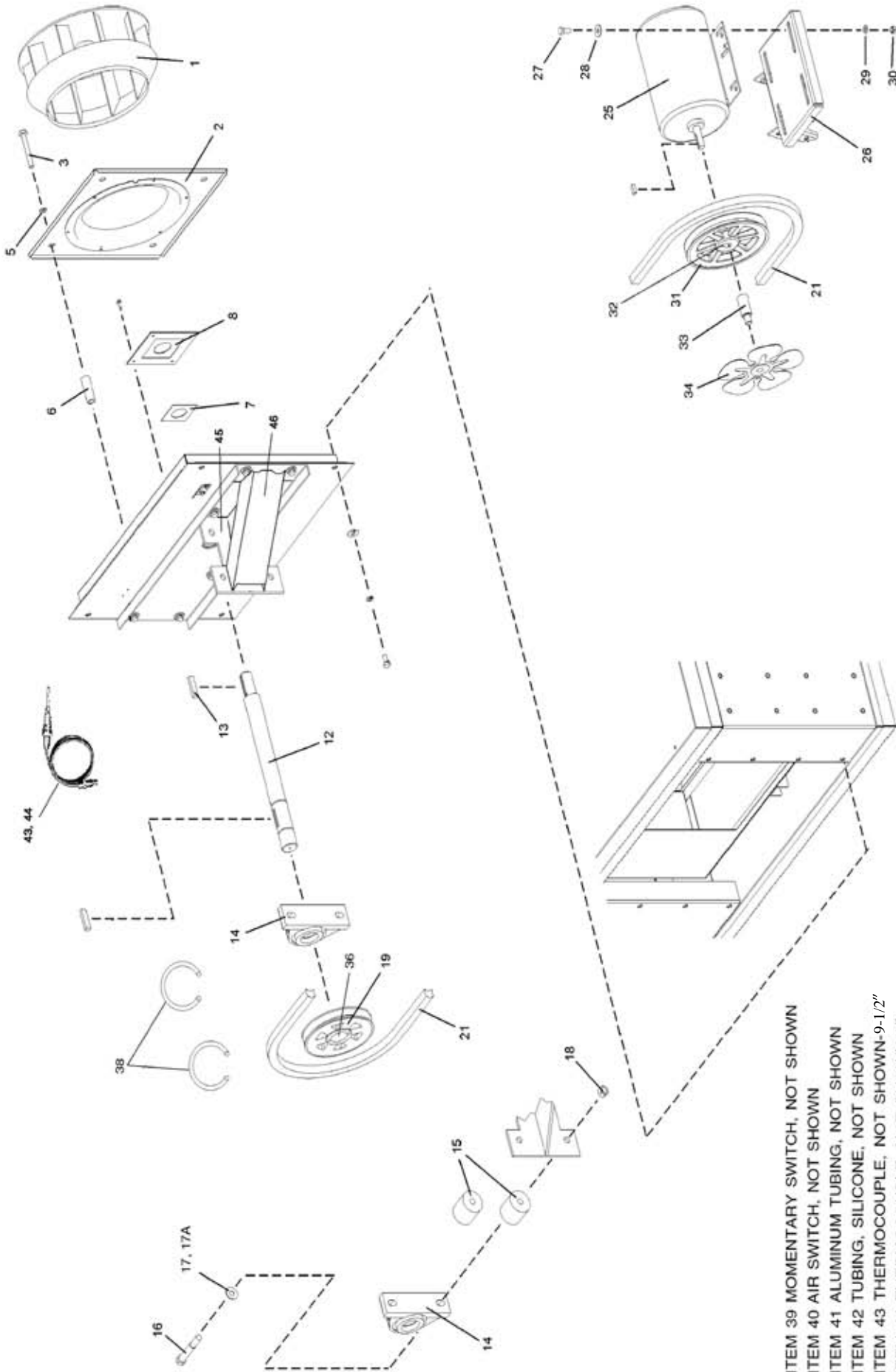

- ITEM 39 MOMENTARY SWITCH, NOT SHOWN
- ITEM 40 AIR SWITCH, NOT SHOWN
- ITEM 41 ALUMINUM TUBING, NOT SHOWN
- ITEM 42 TUBING, SILICONE, NOT SHOWN
- ITEM 43 THERMOCOUPLE, NOT SHOWN-9-1/2"
- ITEM 44 THERMOCOUPLE, NOT SHOWN-6"
- ITEM 47 PHOTO CELL
- ITEM 48 MOUNTING BRACKET, PHOTO CELL

**NOTE: IDENTIFY THE DEFECTIVE INNER FROM THE DEFECTIVE OUTER BEARING ITEM 14 PER ENGINEERING'S REQUEST (THESE PARTS ARE TO BE RETURNED FOR OUR INSPECTION)**

## Parts for EACH REAR COMPARTMENT AND BLOWER

ITEM QTY.	P/N	DESCRIPTION
1A 1	22521-0005	BLOWER WHEEL, IDLER END
1B 1	22521-0006	BLOWER WHEEL, CONVEYOR DRIVE END
2 1	37210-0124	PLATE, INLET RING
3 4	21211-0001	SCREW, CAP HEX HD 3/8"-16 x 3"
5 10	21422-0001	LOCKWASHER, SPLIT 3/8"
6 4	35210-0576	SPACER
7 1	35210-0541	SHAFT SEAL, PTFE
8 1	37210-0101	PLATE, SHAFT SEAL INNER
12 1	57323	SHAFT BLOWER
13 1	35210-0286	KEY, BLOWER WHEEL
14 2	57321	BEARING
15 4	57320	SPACER, BEARING
16 4	2000535	SCREW, CAP HEX HD
17 4	A6235	FLATWASHER, 7/17"
17A 4	21422-0016	LOCKWASHER
18 4	21121-0013	HEX NUT, 1/2"-13
19 1	57295	PULLEY, 5"
21 1	58777	BELT
25 1	57288	MOTOR, BLOWER 2HP
26 1	59133	BRACKET, MOTOR MOUNTING
27 4	6673	SCREW, CAP HEX HD 5/16"-18 x 1"

ITEM QTY.	P/N	DESCRIPTION
28 4	A3682	LOCKWASHER, SPLIT 5/16"
31 1	57296	PULLEY, 5.6"
32 1	57297	INSERT, 5/8"
33 1	43024	EXTENDER, FAN
34A 1	27399-0008	FAN BLADE, CW, 8", CONVEYOR DRIVE END
34B 1	27399-0009	FAN BLADE, CCW, 8", IDLER END
35 1	57316	BRACKET, MOTOR SUPPORT
36 1	57298	INSERT, 1-7/16"
37 1	Contact Factory	KEY, 5/8 x 1
38 2	57325	RING
39 1	28021-0061	SWITCH, MOMENTARY
40 1	50610	AIR SWITCH
41 AP	15125-0002	ALUMINUM TUBING
42 AP	22450-0297	TUBING, SILICONE
43 4	33812-6	THERMOCOUPLE, 12" x 120", REAR OF OVEN
44 1	33812-1	THERMOCOUPLE 6" (HIGH LIMIT) (33984)
45 1	41575	MOUNTING BRACKET
46 1	44550	SUPPORT BRACKET
47 1	59112	PHOTO CELL, 24V DC
48 1	59108	MOUNTING BRACKET, PHOTO CELL

View of Single-Belt Conveyor

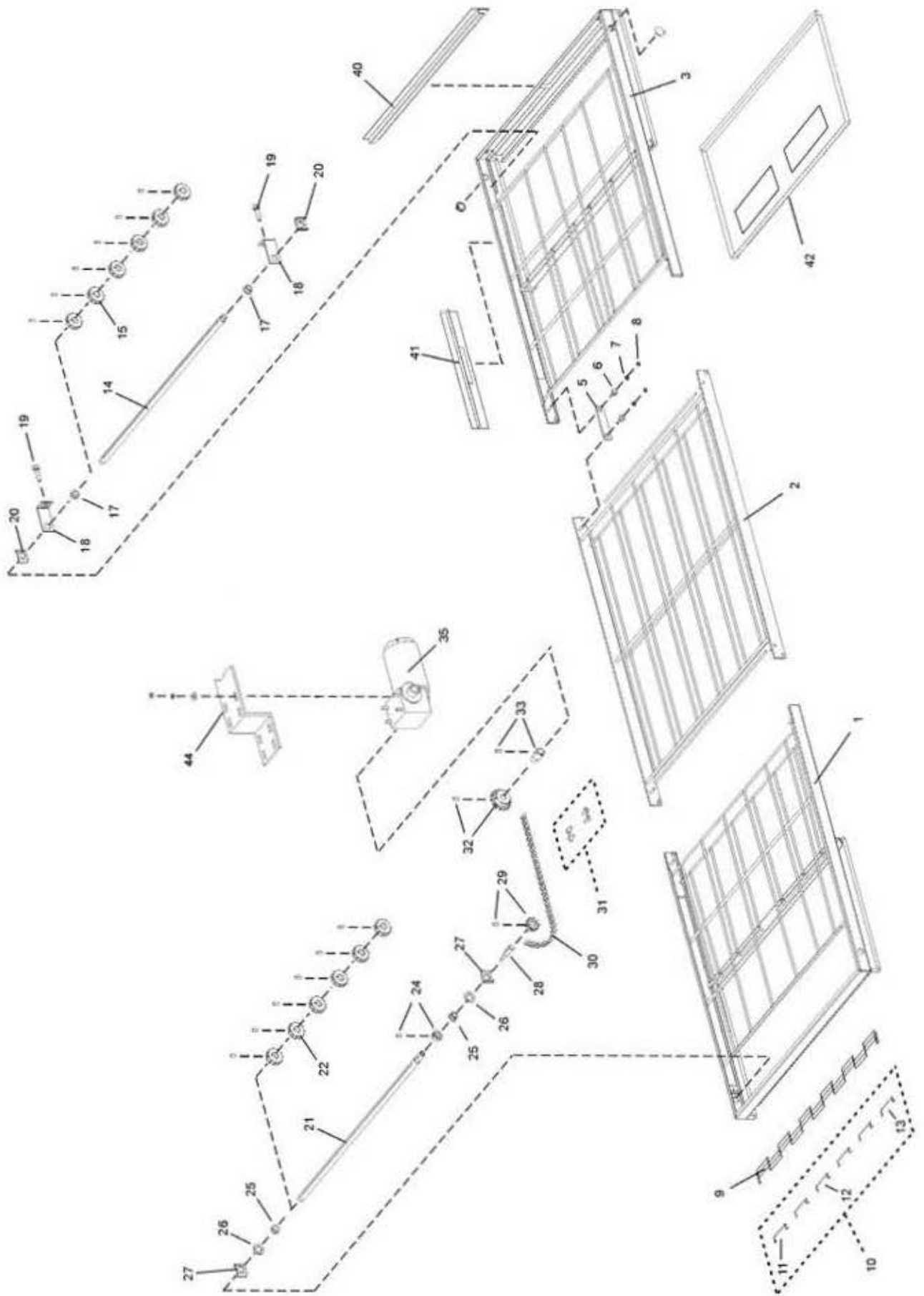

## Parts for Single-Belt Conveyor

ITEM	QTY	PART NO.	DESCRIPTION	ITEM	QTY	PART NO.	DESCRIPTION
1	1	37210-0117	WELDMENT, CONVEYOR DRIVE FRAME	22	6	22229-0003	SPROCKET, CONVEYOR BELT
2	1	37210-0046	WELDMENT, CONVEYOR CENTER FRAME	24	1	22011-0013	COLLAR, SHAFT, WITH SET SCREW
3	1	37210-0116	WELDMENT, CONVEYOR IDLER FRAME	25	2	22034-0003	BUSHING, BRONZE 3/4" O.D. x 5/8" I.D.
5	4	35210-0429	PIVOT PLATE	26	2	35000-1080	SPACER, NYLON 1-1/4" O.D. x 3/4" I.D.
6	8	35210-0491	BUSHING, CONVEYOR ADJUSTMENT	27	2	54947	BRACKET, SHAFT SUPPORT
7	8	F716A8805	WASHER, EXTERNAL TOOTH 1/4"	28	1	35000-1013	ADAPTER, DRIVE SHAFT
8	8	21176-0001	LOCKNUT, HEX 1/4"-20	29	1	22152-0017	SPROCKET, DRIVE SHAFT, 5/8" BORE, 9T, WITH SET SCREW
9A	1	22450-0265	CONVEYOR BELT, COMPLETE, 32"W x 206"L	30	1	42400-0164	ASSEMBLY, ROLLER CHAIN (62 LINKS) WITH MASTERLINK
9B	--	33900-0032	CONVEYOR BELT, 32"W x 12"L (0.81 x 0.30m)	31	1	22273-0001	MASTERLINK, ROLLER CHAIN
10	1	51380	MASTERLINKS KIT, 32" (0.81m) BELT (INC. ITEMS 11-13)	32	1	22152-0018	SPROCKET, DRIVE MOTOR, 5/8" BORE, 15T, WITH SET SCREW
11	1	--	MASTERLINK, LEFT	33	1	35210-0640	ADAPTER, DRIVE MOTOR WITH SET SCREW
12	4	--	MASTERLINK, CENTER	35	1	58678	DRIVE MOTOR, BRUSHLESS, 1400:1 130VDC
13	1	--	MASTERLINK, RIGHT	40	1	55027	END STOP, CONVEYOR, 29-1/4" LONG
14	1	35000-1011	SHAFT, IDLER	41	1	55028	REAR STOP, CONVEYOR, 18" LONG
15	6	22229-0003	SPROCKET, CONVEYOR BELT	42	2	30004	CRUMB PAN
17	2	22034-0003	BUSHING, BRONZE 3/4" O.D. x 5/8" I.D.	43	1	M10098	HARNESS, WIRE
18	2	37000-0413	BRACKET, IDLER SHAFT ADJUSTMENT	44	1	45035	MOUNTING BRACKET, DRIVE MOTOR
19	2	35000-1008	SCREW, CONVEYOR TENSION ADJUSTMENT				
20	2	54947	BRACKET, SHAFT SUPPORT				
21	1	35000-1012	SHAFT, DRIVE				

View of "SPLIT" 50/50 Belt Conveyor (15' Width)

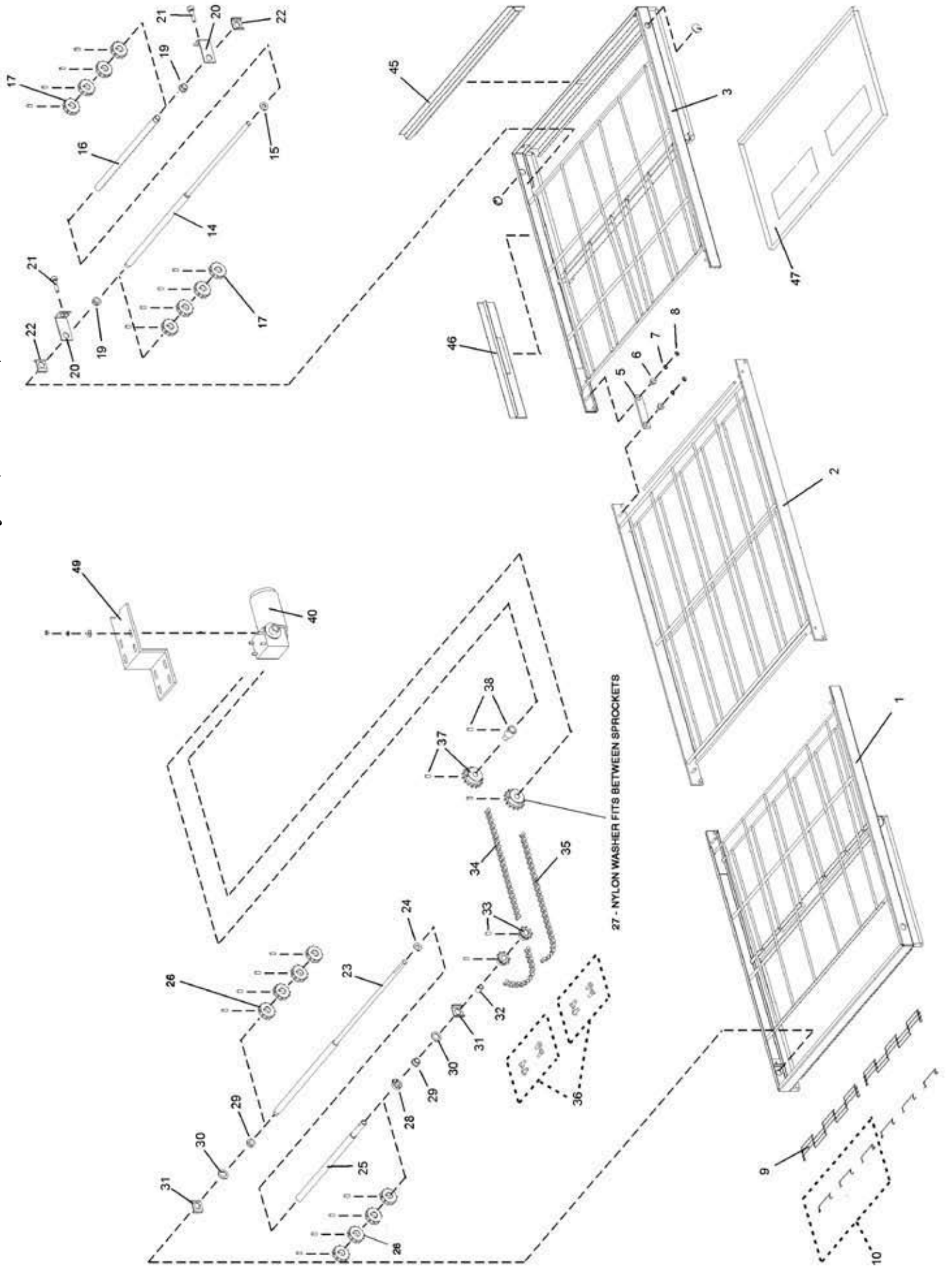

## Parts for "SPLIT" 50/50 Belt Conveyor (15" Width)

ITEM	QTY	PART NO.	DESCRIPTION	ITEM	QTY	PART NO.	DESCRIPTION
1	1	37210-0117	WELDMENT, CONVEYOR DRIVE FRAME	26	8	22229-0003	SPROCKET, CONVEYOR BELT
2	1	37210-0046	WELDMENT, CONVEYOR CENTER FRAME	27	1	35000-1531	SPACER, NYLON, FITS BETWEEN SPROCKET
3	1	37210-0116	WELDMENT, CONVEYOR IDLER FRAME	28	1	22011-0014	COLLAR, SPLIT LOCKING
5	4	35210-0429	PIVOT PLATE	29	2	22034-0003	BUSHING, BRONZE 3/4" O.D. x 5/8" I.D.
6	8	35210-0491	BUSHING, CONVEYOR ADJUSTMENT	30	2	35000-1080	SPACER, NYLON 1-1/4" O.D. x 3/4" I.D.
7	8	F716A8805	WASHER, EXTERNAL TOOTH 1/4"	31	2	54947	BRACKET, SHAFT SUPPORT
8	8	21176-0001	LOCKNUT, HEX 1/4"-20	32	1	35900-0023	BUSHING, SPLIT BELT DRIVE SPROCKET
9A	2	22450-0271	CONVEYOR BELT, COMPLETE, 15"W x 206"L (0.38 x 5.23m)	33	2	22152-0017	SPROCKET, DRIVE SHAFT, 5/8" BORE, 9T, WITH SET SCREW
9B	--	33900-0037	CONVEYOR BELT, 15"W x 12"L (0.38 x 0.30m)	34	1	42400-0164	ASSEMBLY, ROLLER CHAIN COMPLETE (62 LINKS)
10	2	51382	MASTERLINKS KIT, 15" (0.81m) BELT (INC. ITEMS 11-13)	35	1	42410-0128	ASSEMBLY, ROLLER CHAIN COMPLETE (48 LINKS)
14	1	42400-0354	SHAFT, IDLER, REAR, 32-3/4"	36	2	22273-0001	MASTERLINK, ROLLER CHAIN
15	1	21415-0001	FLAT WASHER, BRONZE, 1" O.D. X 1/2" I.D.	37	2	22152-0018	SPROCKET, DRIVE MOTOR, 5/8" BORE, 15T, WITH SET SCREW
16	1	35000-1535	SHAFT, IDLER, FRONT, 16-3/8"	38	1	35210-0640	ADAPTER, DRIVE MOTOR WITH SET SCREW
17	8	22229-0003	SPROCKET, CONVEYOR BELT	40	2	58678	DRIVE MOTOR, BRUSHLESS, 1/8HP, 1400:1
19	2	22034-0003	BUSHING, BRONZE 3/4" O.D. x 5/8" I.D.	45	1	55027	END STOP, CONVEYOR, 29-1/4"
20	2	37000-0413	BRACKET, IDLER SHAFT ADJUSTMENT	46	1	55028	REAR STOP, CONVEYOR, 18"
21	2	35000-1008	SCREW, CONVEYOR TENSION ADJUSTMENT	47	2	30004	CRUMB PAN
22	2	54947	BRACKET, SHAFT SUPPORT	48	2	M10098	HARNESS, WIRE
23	1	42400-0355	SHAFT, DRIVE, REAR, 35-1/3"	49	1	45035	MOUNTING BRACKET, DRIVE MOTOR
24	1	21415-0001	FLAT WASHER, BRONZE, 1" O.D. X 1/2" I.D.				
25	1	35000-1536	SHAFT, DRIVE, FRONT, 17-3/4"				

**View of 12"/18" Split 40/60 Belt Conveyor**

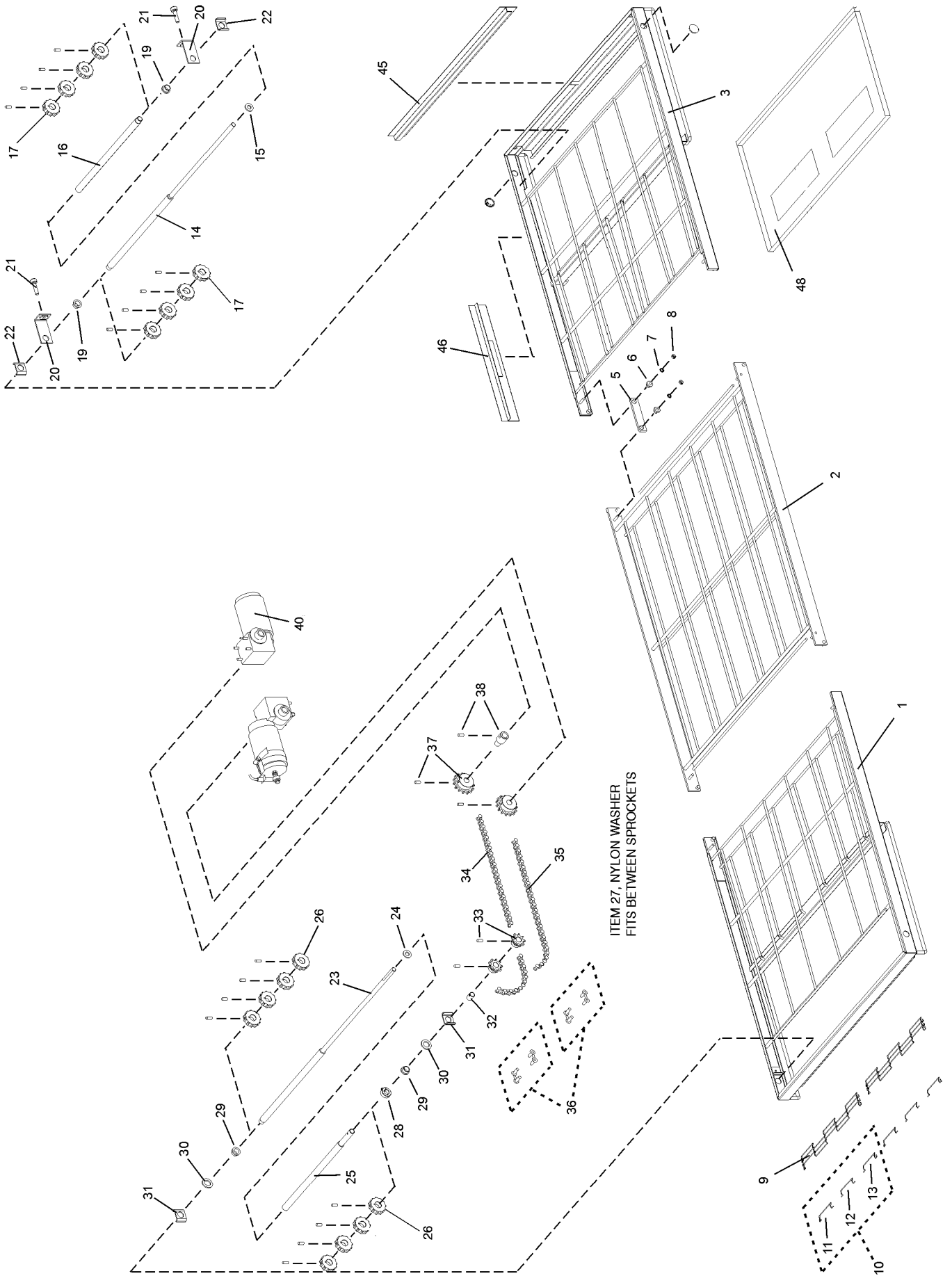

## Parts for 12"/18" Split 40/60 Belt Conveyor

ITEM QTY.	P/N	DESCRIPTION
1	37210-0117	WELDMENT, CONVEYOR DRIVE FRAME
2	37210-0046	WELDMENT, CONVEYOR CENTER FRAME
3	37210-0116	WELDMENT, CONVEYOR IDLER FRAME
5	35210-0429	PIVOT PLATE
6	35210-0491	BUSHING, CONVEYOR ADJUSTMENT
7	F716A8805	WASHER, EXTERNAL TOOTH 1/4"
8	21176-0001	LOCKNUT, HEX 1/4"-20
9A	41650	CONVEYOR BELT, COMPLETE, 12"W x 204"L
9B	—	CONVEYOR BELT, 12"W x 12"L
9C	41651	CONVEYOR BELT, COMPLETE, 18"W x 204"L
9D A/R	8500236	CONVEYOR BELT, 18"W x 12"L
10A	—	MASTERLINK KIT, 12" BELT
10B	58391	MASTERLINK KIT, 18" BELT
11	—	MASTERLINK, LEFT
12	—	MASTERLINK, CENTER
13	—	MASTERLINK, RIGHT
14	41654	SHAFT, IDLER, REAR, 32.87" L 18" SECTION
15	21415-0001	FLAT WASHER, BRONZE, 1" O.D. X 1/2" I.D.
16	41653	SHAFT, IDLER, FRONT, 13.37" L 12" SECTION
17	22229-0003	SPROCKET, CONVEYOR BELT
19	22034-0003	BUSHING, BRONZE 3/4" O.D. x 5/8" I.D.
20	37000-0413	BRACKET, IDLER SHAFT ADJUSTMENT
21	35000-1008	SCREW, CONVEYOR TENSION ADJUSTMENT
22	54947	BRACKET, SHAFT SUPPORT
23	41659	SHAFT, DRIVE, REAR, 35.31" L 18" SECTION

ITEM QTY.	P/N	DESCRIPTION
24	21415-0001	FLAT WASHER, BRONZE, 1" O.D. X 1/2" I.D.
25	41658	SHAFT, DRIVE, FRONT, 14.81" L 12" SECTION
26	22229-0003	SPROCKET, CONVEYOR BELT
27	35000-1531	SPACER, NYLON-FITS BETWEEN SPROCKETS
28	22011-0014	COLLAR, SPLIT LOCKING
29	22034-0003	BUSHING, BRONZE 3/4" O.D. x 5/8" I.D.
30	35000-1080	SPACER, NYLON 1-1/4" O.D. x 3/4" I.D.
31	54947	BRACKET, SHAFT SUPPORT
32	35900-0023	BUSHING, SPLIT BELT DRIVE SPROCKET
33	22152-0017	SPROCKET, DRIVE SHAFT, 5/8" BORE, 9T, WITH SET SCREW
34	42400-0164	ASSEMBLY, ROLLER CHAIN COMPLETE (62 LINKS)
35	42410-0128	ASSEMBLY, ROLLER CHAIN COMPLETE (48 LINKS)
36	22273-0001	MASTERLINK, ROLLER CHAIN
37	22152-0018	SPROCKET, DRIVE MOTOR, 5/8" BORE, 15T, WITH SET SCREW
38	35210-0640	ADAPTER, DRIVE MOTOR WITH SET SCREW
40	58678	DRIVE MOTOR, BRUSHLESS, 1/8 HP, 1400:1
45	55027	END STOP, CONVEYOR, 29-1/4" LONG
46	55028	REAR STOP, CONVEYOR, 18" LONG
48A	30004	CRUMB PAN, ALUMINIZED (WITH OPENINGS)



REV	DATE	ECN	REVISION DESCRIPTION	BY	CHK	DATE
B	11/28/2004	004286	RELEASE TO PRODUCTION	AJ	AJ	11/28/2004
C	02/28/2007	004363	ADDED STANDARD TO PARTITION KIT	AJ	MSS	02/27/2007
D	03/05/2007	007034	CHG DESC WAS CONFIG, PHOR PS870M PHI@2415RPM, ADDED PARTITIONS TO DRAWING	FC	AJ	03/07/2007



# PS870G PIZZA HUT

LEFT-TO-RIGHT or RIGHT-TO-LEFT CONVEYOR DIRECTION

Finger Arrangement:  
PIN 59730 Rev.D 03/5/07

Low Altitude ID - 3000 III  
Belt line: 6 mins. 30 secs.  
Temperature: 440°F/227°C

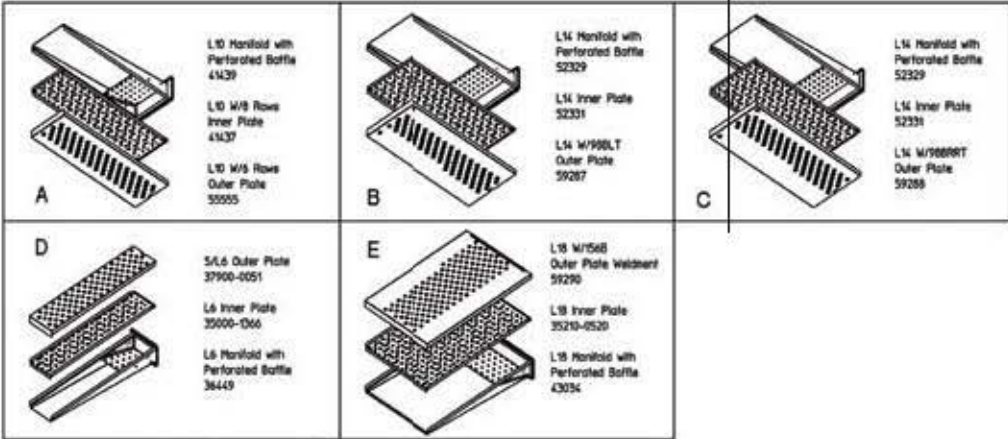
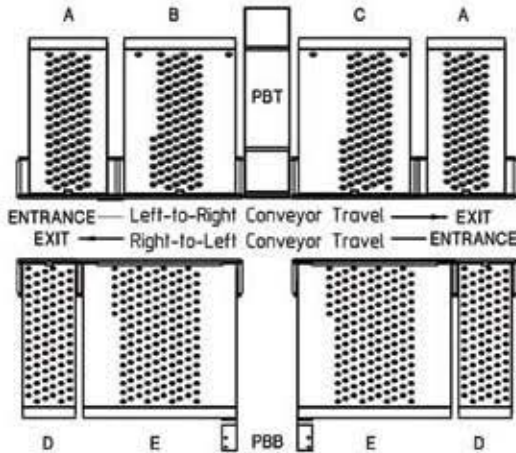

Right to Left or Left to Right - No Change to Finger Config  
RPM: 2415 (Inverters Set @ 74 Hz)  
PBT: Partition Box Top  
PBB: Partion Bracket Bottom (2 Required)

27

MATERIAL	GUAGE:	TOLERANCE UNLESS SPECIFIED	THIS DRAWING IS CONFIDENTIAL AND PROPERTY OF <b>THE MIDDLEBY CORPORATION</b> 1400 Toddmaster Drive Elgin, Illinois 60120 847-741-3300
NYLAR		ANGLES ± 1.0°	
FINISH		DEC .X ± .030 .XX ± .015 .XXX ± .005	
DRAWN	CHECKED	APPROVED	
FC 03/05/2007	AJ 03/07/2007	AJ 03/07/2007	

①	LBL, FGR CNFG 870G PHI@2415RPM		
ALL DIMENSIONS ARE IN INCHES UNLESS OTHERWISE SPECIFIED. DO NOT SCALE DRAWING	PART NO 59730-1	SHT 1 of 1	REV D

REV	DATE	ECN	REVISION DESCRIPTION	BY	CHK	DATE
E	09/19/2006	006285	REVERSED POSITIONS OF TC2 & TC3	FC	WSS	09/19/2006
F	11/28/2006	006286	REMOVED RPM FROM DESCRIPTION	AJ	AJ	11/28/2006
G	02/20/2007	007034	CHANGED DESCRIPTION FROM 870M TO 870G	AJ	WSS	02/27/2007

# PS870G PHI

EXIT ← CONVEYOR DIRECTION - LEFT TO RIGHT → ENTRANCE

NOTE: WIRE ALL TC2 PROBES TO TC2 TERMINAL

NOTE: WIRE ALL TC3 PROBES TO TC3 TERMINAL

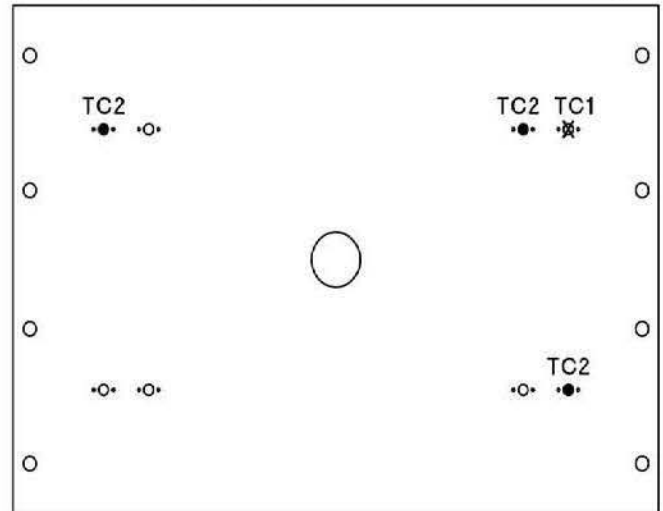
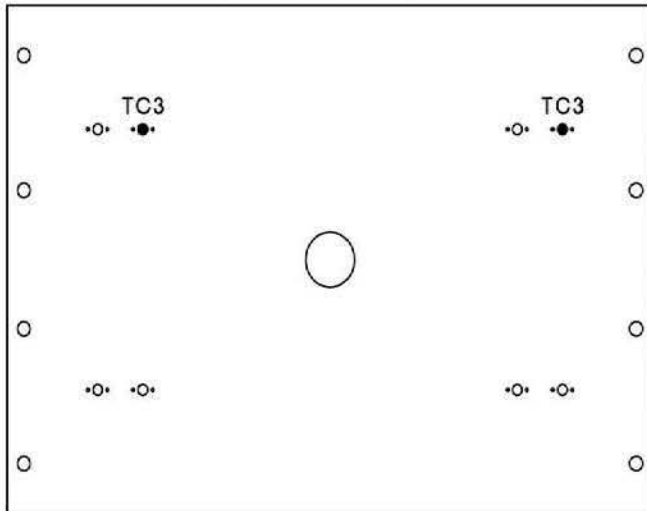

- (5) 9.5" CONTROL PROBES (P/N 33812-7)
- \*• (1) 6" HIGH LIMIT PROBE (P/N 33812-1)

## REAR VIEW

P/N: 59072 REV.G

MATERIAL MYLAR	GAUGE:	TOLERANCE UNLESS SPECIFIED ANGLES ± 1.0° DEC .X ± .030 .XX ± .015 .XXX ± .005	THIS DRAWING IS CONFIDENTIAL AND PROPERTY OF <b>THE MIDDLEBY CORPORATION</b> 1400 Toastmaster Drive Elgin, Illinois 60120 847-741-3300
FINISH			
DRAWN AJ 02/20/2007	CHECKED WSS 02/27/2007	APPROVED WSS 02/27/2007	

ⓐ

LBL, TC L/R PS870G PHI

ALL DIMENSIONS ARE IN INCHES UNLESS OTHERWISE SPECIFIED. DO NOT SCALE DRAWING

PART NO

59072

SHT

1 OF 1

REV

G\_

REV	DATE	ECN	REVISION DESCRIPTION	BY	CHK	DATE
E	08/30/2006	006285	REVERSED POSITION OF TC1, TC2 & TC3	FC	WSS	09/19/2006
F	11/28/2006	006286	REMOVED RPH FROM DESCRIPTION	AJ	AJ	11/28/2006
G	02/20/2007	007034	CHANGED DESCRIPTION FROM 870H TO 870G	AJ	WSS	02/27/2007

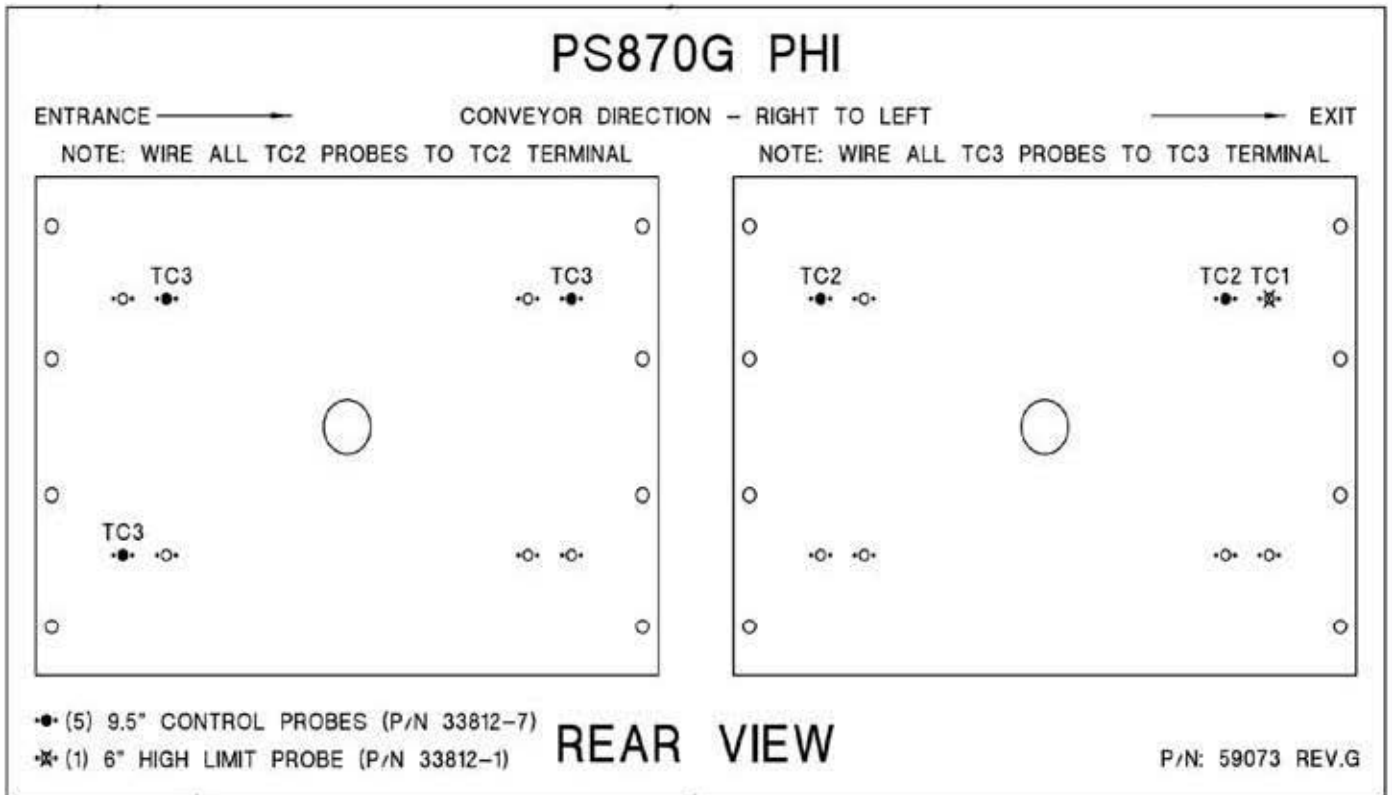

MATERIAL MYLAR	GAUGE:	TOLERANCE UNLESS SPECIFIED ANGLES $\pm 1.0^\circ$ DEC .X $\pm .030$ .XX $\pm .015$ .XXX $\pm .005$	THIS DRAWING IS CONFIDENTIAL AND PROPERTY OF <b>THE MIDDLEBY CORPORATION</b> 1400 Toastmaster Drive Elgin, Illinois 60120 847-741-3300
FINISH			
DRAWN AJ	CHECKED WSS	APPROVED WSS	
02/20/2007	02/27/2007	02/27/2007	
<b>LBL, TC R/L PS870G PHI</b>			
ALL DIMENSIONS ARE IN INCHES UNLESS OTHERWISE SPECIFIED. DO NOT SCALE DRAWING.		PART NO <b>59073</b>	SHT 1 OF 1
			REV <b>G</b>

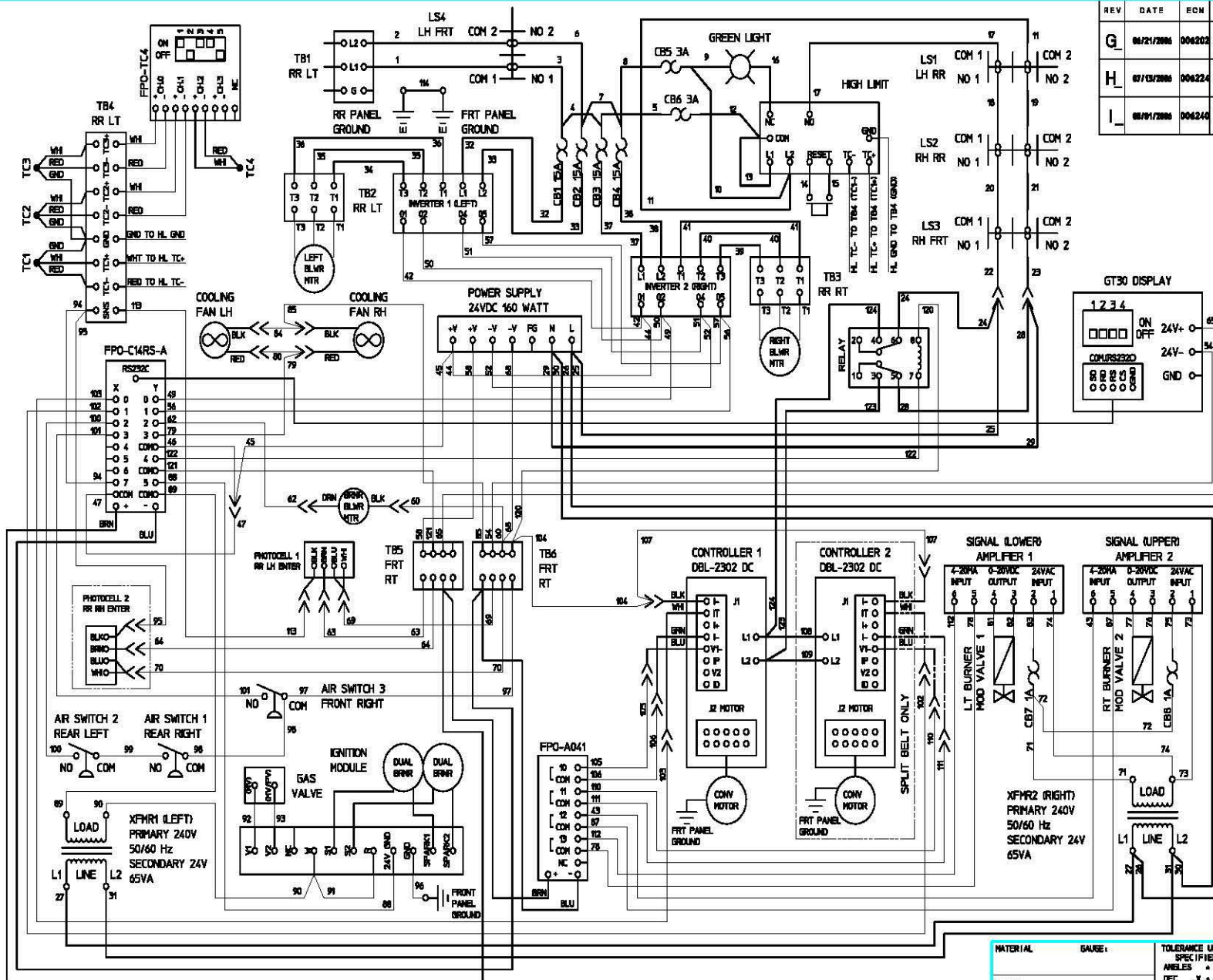

REV	DATE	EON	REVISION DESCRIPTION	BY	CHK	DATE
G	06/21/2006	006202	REVERSED COLORS ON TC1 & CONNECTED SIGNAL AMPLIFIER INPUT & OUTPUT	WPN	MSB	06/21/2006
H	07/13/2006	006222	REVERSED POSITIONS (L & R) ON POWER SUPPLY	PC	MSB	07/17/2006
I	08/01/2006	006242	CHG'D CONNECTOR POSITION NUMBERS	AB	MSB	08/01/2006

WD LABEL P/N 58813

MATERIAL	GAGE:	TOLERANCE UNLESS SPECIFIED	THIS DRAWING IS CONFIDENTIAL AND PROPERTY OF <b>THE MIDDLEBY CORPORATION</b> 1400 Toastmaster Drive Elgin, Illinois 60120 847-741-3300
FINISH		ANGLES ± 1.0° DEC .X ± 0.30 .XX ± 0.15 .XXX ± 0.05	
DRAWN	CHECKED	APPROVED	
AB	08/01/2006	MSB	08/01/2006

WD, G208-240/50/60/1 PS870/770  
 ALL DIMENSIONS ARE IN INCHES UNLESS OTHERWISE SPECIFIED. DO NOT SCALE DRAWING  
 PART NO 54745  
 SHIT 1 OF 1  
 REV I

