



SPL012706-PF-BD
Dated: January 27, 2006
Replaces: P/N 39443
Rev. C VI 3/99

Parts Manual

*& operating instructions, programming,
error codes & wiring diagrams*

MODEL TCO2114C MIGHTY CHEF CONVEYOR OVEN

Serial # Code

First 4 digits - order of production

Fifth digit - model specific

Sixth and Seventh digit - month of production

Eighth and Ninth digit - year of production

TABLE OF CONTENTS: PAGE 2

For Owner's Operating & Installation Manual
See P/N 43336
Rev, B VI 5/00
on our website

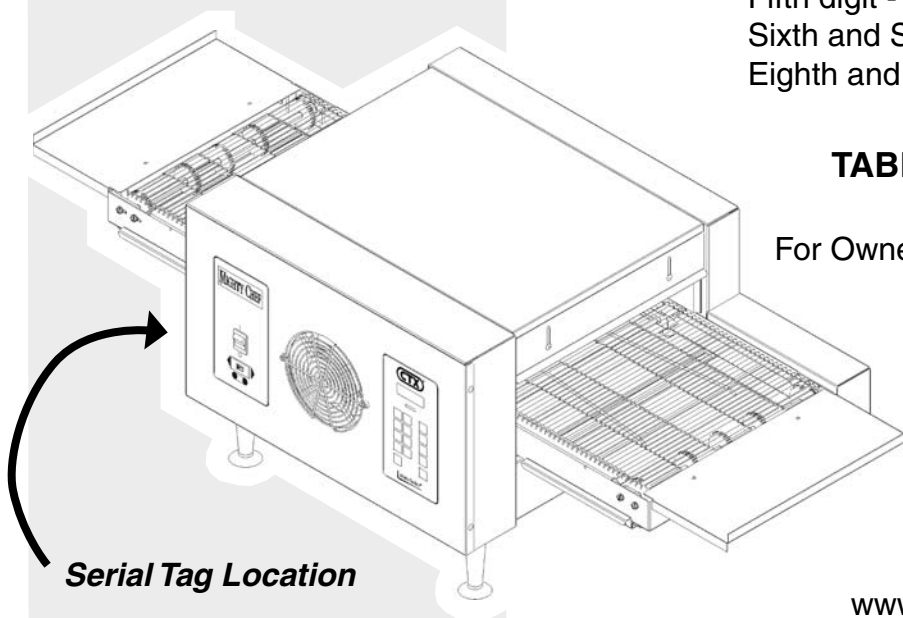

2006 Middleby Marshall Inc.

www.middleby.com

email: techsupport@middleby.com

1-847-741-3000 fax 1-847-741-4406 (Parts Department)



is a registered trademark of Middleby Marshall, Inc. All rights reserved.
Middleby Cooking Systems Group • 1400 Toastmaster Drive • Elgin, IL 60120

TABLE OF CONTENTS

Specification Sheet.	3
Operation Instructions & Shutdown Procedure	5
Programming Preset Menu Selections.	6
Display Messages and Error Codes	7
View of Body Panels and Legs.	8
Parts for Body Panels and Legs	9
View of Front and Rear Components	10
Parts for Front and Rear Components Parts List	11
View of Front Panel and Control Components.	12
Parts for Front Panel and Control Components	13
View of Conveyer System	14
Parts for Conveyer System	15
Wiring Diagram (US) 208/240V 1-Phase 38248F Sheet 1.	16
Ladder Diagram (US) 208/240V 1-Phase 38248F Sheet 2	17
Wiring Diagram (US) 208V 3-Phase 51351D Sheet 1	18
Ladder Diagram (US) 208V 3-Phase 51351D Sheet 2	19
Wiring Diagram (EUROPEAN) 230V 1-Phase 38703E Sheet 1	20
Ladder Diagram (EUROPEAN) 230V 1-Phase 38703E Sheet 2	21
Wiring Diagram (EUROPEAN) 380/400V 3-Phase 38710G Sheet 1	22
Ladder Diagram (EUROPEAN) 380/400V 3-Phase 38710G Sheet 2	23



Infrared Conveyor Ovens

Foodservice Equipment

Job _____ Item# _____

Mighty Chef® Countertop Conveyor Oven

Patented



Model TCO2114

New conveyor oven with precision electronics.

- High production with consistent quality
- Precise cook times and temperatures can be entered into patented MenuSelect® control
- Five (5) programmable menus, each has independent time and temperature selections.
- Electronically calibrated for accurately maintaining precise temperatures
- Top and bottom temperatures are individually controlled
- Safe, cool exterior

Application

Conveyor ovens are designed to easily and quickly cook, bake or broil with consistent quality results. Ideal for pizza, garlic toast, cookies, sandwiches, pretzels and much more.

General Information

The conveyor oven is designed for placement on a countertop and can be stacked up to 3 high with stacking brackets. The oven is equipped with a 14" wide, stainless steel chain-link belt. Selecting the direction from the mechanical switch can easily reverse the belt direction. The overall dimensions are 22"W x 54.5"L x 17.6"H, including legs, and the oven chamber is 22"W x 14.5"D x 3"H. The installed weight is 98 lbs. The oven is supplied with crumb trays, conveyor end trays and adjustable heat curtains.

Construction

The oven is constructed of welded and reinforced stainless steel. The outer case has a unique air-cooled "cool case", patented design, that is cool-to-the-touch.

Heating

There are upper and lower independent, pre-formed tubular heaters that radiate the heat throughout the cooking chamber. Heaters are controlled by electronic thermostats. The allowable temperature range is 200°F - 599°F (93°C - 315°C), and the cook time range is 30 seconds to 15 minutes.

Electrical

The oven is wired 208V or 240V, 60 Hz, 1-phase; or 230V, 50 Hz, 1-phase; or 380-400V, 50 Hz, 3-phase. See electrical information chart on back. The oven is rated at 5.0kW on 208V, 230V and 380-400; oven is rated 5.3kW when used on 240V. 208V and 240V ovens are equipped with an attached 6-ft electrical cord and 6-30P NEMA plug; 230V oven is equipped with 1.8 m cord & IEC 309 plug; 380-400V ovens require field wiring.

MenuSelect® Control

The patented MenuSelect® control feature allows the operator to preset up to five (5) different times and temperatures into the control. The control accurately executes the times and temperatures automatically, and a ready light glows when the desired temperatures are reached.

Warranty

Warranted for one year covering parts and on-site labor under the "No Quibble" warranty (USA only).

Ordering Information

- 208V, 1-Phase, 50/60 Hz
- 230V, 1-Phase, 50/60 Hz (CE Version)
- 240V, 1-Phase, 50/60 Hz
- 380-400V, 3-Phase, 50 Hz (CE Version)

Accessories

- [T2114Stack](#) - Stacking Bracket

TCO 2114



6-30P NEMA Plug
208/240V, 50/60Hz

TCO 2114



IEC 309
230V, 50/60Hz



Form 2206







A MIDDLEBY COMPANY



1400 Toastmaster Drive
Elgin, Illinois 60120 USA
(847) 741-3300 Fax: (847) 741-0015
www.middleby.com

OPERATION INSTRUCTIONS

1. **TO PROGRAM A NEW PRESET MENU SELECTION:** Perform the procedure in Part E, Programming Preset Menu Selections in this Section. At least one menu selection **MUST** be programmed before the oven can be operated.



 2. **TO TEMPORARILY OVERRIDE A PRESET MENU SELECTION:** Perform the procedure in Part E, Programming Preset Menu Selections **BUT** press  instead of  (in Steps 3 and 8). Instead of permanently overwriting the menu selection, the new set temperature and cook time settings are only temporary. To cancel the temporary menu selection, press any preset menu key or disconnect electrical power to the oven.

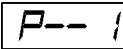



 3. **TO CHOOSE A PRESET MENU SELECTION:**
 - a. Press  (or any other preset menu key). The display will read . The number in the display (1 is shown above) will match the menu key that was pressed (1-5).
 - b. Wait for the  light to illuminate. The light will illuminate after both heating zones reach their set temperatures.
 - c. Load the product onto the conveyor.

 4. **TO COOK A SINGLE PIZZA, OR THE LAST OF A GROUP OF PIZZAS:**
 - a. Choose a preset menu selection, and wait for the  light to illuminate.
 - b. Press  .  and  will alternate in the display. The number in the display (1 is shown above) will match the current menu selection (1-5).
 - c. Load the pizza product onto the conveyor.

IMPORTANT
After 1/2 of the cook time has elapsed, the temperature of the top zone will be automatically lowered. After the entire cook time has elapsed, the program will return to its normal top zone temperature.

After  is pressed, the menu selection cannot be changed until the cook time has elapsed.

 5. **TO VIEW THE SET TEMPERATURES:** Press either  or  . The top or bottom set temperature will be displayed for 5 seconds.

 6. **TO VIEW HEATING ZONE REFERENCE TEMPERATURES:** Press  +  or  +  . The top or bottom reference temperature will be displayed for 5 seconds.

 7. **TO VIEW THE COOK TIME:** Press  . The cook time will be displayed for 5 seconds.
-

SHUTDOWN PROCEDURE

1. Switch the Power On/Off (I/O) switch to the OFF (iOî) position.

2. Wait for the oven's cooling fan to turn off.

3. Disconnect electrical power to the oven at the circuit breaker/fused disconnect.

PROGRAMMING PRESET MENU SELECTIONS

IMPORTANT

Adding a menu program to the oven will overwrite an existing program. DO NOT enter a new menu program over an existing program that you wish to keep!

1. Restore power to the oven at the circuit breaker/fused disconnect.



2. Switch the Power On/Off (I/O) Switch to the ON (iŕ) position.

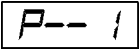

3. Press and hold  until  appears in the display.



4. **CHOOSE A MENU SELECTION TO PROGRAM** Press and hold  (or any other preset menu key) until  appears in the display and begins to flash. The number in the display (iŕ is shown above) will match the menu key that was pressed (1-5).

5. **SET TOP TEMPERATURE**

a. Press . The current top set temperature appears in the display.

b. Press  and  as necessary to change the displayed temperature.

i Pressing  once increases the iactiveŕ (flashing) digit by one. This digit irolls overŕ to its minimum value if  is pressed when the digit shows its maximum value.



ii Pressing  once causes the next digit to the right to become the iactiveŕ (flashing) digit. If the far-right digit is flashing when  is pressed, the far-left digit will flash and become the iactiveŕ digit.

IMPORTANT

The allowed temperature range is 200-599°F (93-315°C). If you program a set temperature between 0°F (or 0°C) and 99°F (37°C), the heater will be set to OFF. If you program a set temperature between 100°F (38°C) and 199°F (92°C), the temperature will automatically change to 200°F (93°C), the display will flash, and a beep will sound to alert you to the temperature change.

6. **SET BOTTOM TEMPERATURE**

a. Press . The current bottom set temperature appears in the display.



b. Press  and  as necessary to change the displayed temperature.

IMPORTANT

Unless you are following specific time and temperature instructions, the top and bottom zone temperatures should be set WITHIN 50°F (28°C) of each other. Greater temperature differences may cause the hotter zone to heat the cooler zone. This can cause inconsistent cooking results.

7. **SET COOK TIME**







a. Press . The current cook time appears in the display (minutes : seconds).

b. Press  and  as necessary to change the displayed time.



IMPORTANT

The allowed cook time range is 00:30-15:00. If you program a cook time outside of this range, the time will change to the closest allowed time (00:30 if your time was too short, or 15:00 if it was too long). The display will flash, and a beep will sound to alert you to the changed cook time.

8. Press ONE of the following keys:

- , , or  : Re-enter the top setpoint temperature, bottom set point temperature, or cook time.
-  : Turn off Programming Mode. This returns the oven to normal operation.
- Any other key except  or  : Resume operation, but leave Programming Mode active. Other Preset Menu Selections can be programmed at this time.

DISPLAY MESSAGES AND ERROR CODES

DISPLAY SHOWS	PROBLEM	ACTION
Flashing temperatures or cook times during programming, and oven is beeping	Set Temperatures or Cook Time Outside of Allowed Range	Re-enter the program using Set Temperatures and Cook Time within the allowed range. Also, refer to Part E, <i>Programming Preset Menu Selections</i> , in this Section.
OFF	Heating Element turned off	If the element should be on, re-enter the program using Set Temperatures within the allowed range. Also, refer to Part E, <i>Programming Preset Menu Selections</i> in this Section.
----	No Menu Selection Chosen	Choose or program a preset menu selection.
E-00	Preset Menu Program Lost	Re-enter the Preset Menu program.
E-01	High Ambient Condition Temperature inside the control enclosure exceeds 65°C. The oven shuts down, then beeps continuously.	Check the cooling fan (centered on the front panel of the oven) for cleanliness and proper operation. If the fan is not running after the oven heats, or the oven remains in a high ambient condition, contact your local Authorized Service Agent.
E-02	Conveyor Runaway The conveyor runs at full speed. The oven shuts down, then beeps continuously.	Check for the proper speed setting by pressing  . If the speed setting is correct, and the conveyor continues to run at full speed, contact your Authorized Service Agent.
E-04	Conveyor Loose or Jammed Conveyor is stopped when the speed setting is between 0:15 and 15:00.	Switch the Power On/Off (I/O) Switch to the OFF (iOi) position. Switch the breaker/fused disconnect to the OFF position. Allow the oven to cool for at least 30 minutes. <div style="display: flex; align-items: center;">  <p>CAUTION - HOT DO NOT ATTEMPT TO FREE A JAMMED CONVEYOR BELT WHILE THE COOKING CHAMBER IS WARM. SEVERE INJURY MAY RESULT.</p> </div> <p>If the conveyor is jammed, free the obstruction from the conveyor belt. If the conveyor still will not operate properly after the jam is cleared, OR if the error message appears when the conveyor is NOT jammed, contact your local authorized service agent.</p>
E-35	Top Heating Zone Failure	Contact your local authorized service agent.
E-36	Bottom Heating Zone Failure	Contact your local authorized service agent.
E-40	Heating Zone Temperature High Limit One or both of the heating zones have reached a temperature greater than 315°C.	Contact your local authorized service agent.

View of Body Panels and Legs

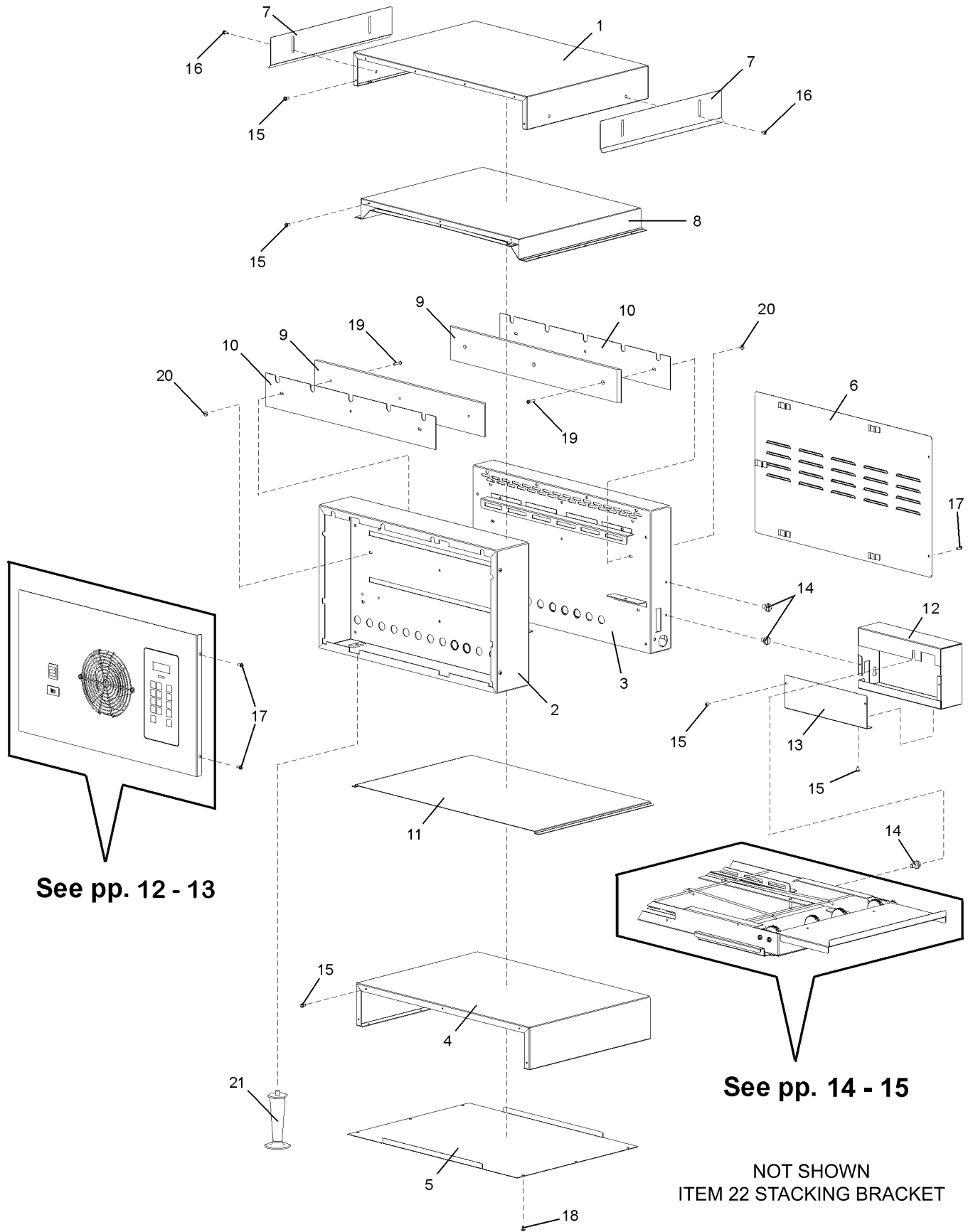

Parts for Body Panels and Legs

ITEM	P/N	QTY.	DESCRIPTION
1	39010	1	TOP COVER PANEL
2	37360	1	FRONT ENCLOSURE
3	37361	1	REAR ENCLOSURE
4	50127	1	BOTTOM ENCLOSURE (FLOOR PANEL), USED AFTER 2/05
4	36689	1	BOTTOM ENCLOSURE (FLOOR PANEL), USED BEFORE 1/05
5	36701	1	BOTTOM COVER PANEL
6	37303	1	REAR COVER PANEL
7	36695	2	ADJUSTABLE HEAT CURTAIN
8	57265	1	TOP REFLECTOR ASSEMBLY, USED AFTER 2/05
8	37362	1	TOP REFLECTOR ASSEMBLY, USED BEFORE 1/05
9	38251	2	EMITTER
10	38252	2	MICA INSULATION PANEL
11	36687	1	BOTTOM REFLECTOR PLATE (CENTER CRUMB TRAY)
12	36696	1	DRIVE CHAIN COVER PLATE, REAR
13	36699	1	DRIVE CHAIN COVER PLATE, FRONT
14	7007413	3	SCREW, SHOULDER
15	3B20A8801	A/R	SCREW, "F" HEX WSHR HD 8-32 X 3/8"
16	21256-0008	4	SCREW, MS SLT TRS HD 10-32 X 3/8"
17	2000096	4	SCREW, MS SLT TRS HD 8-32 X 1/4"
18	B301A8803	6	SCREW, "AB" PHIL TRS HD 8-32 X 1/4"
19	2000144	6	SCREW, MS PHIL PAN HD 8-32 X 3/4"
20	2001347	6	NUT, KEPS 8-32
21	34979	4	LEG ASSEMBLY, 4" (102mm) WITH SUCTION CUP
22	39130	2	STACKING BRACKET

View of Front & Rear Components
Front Components

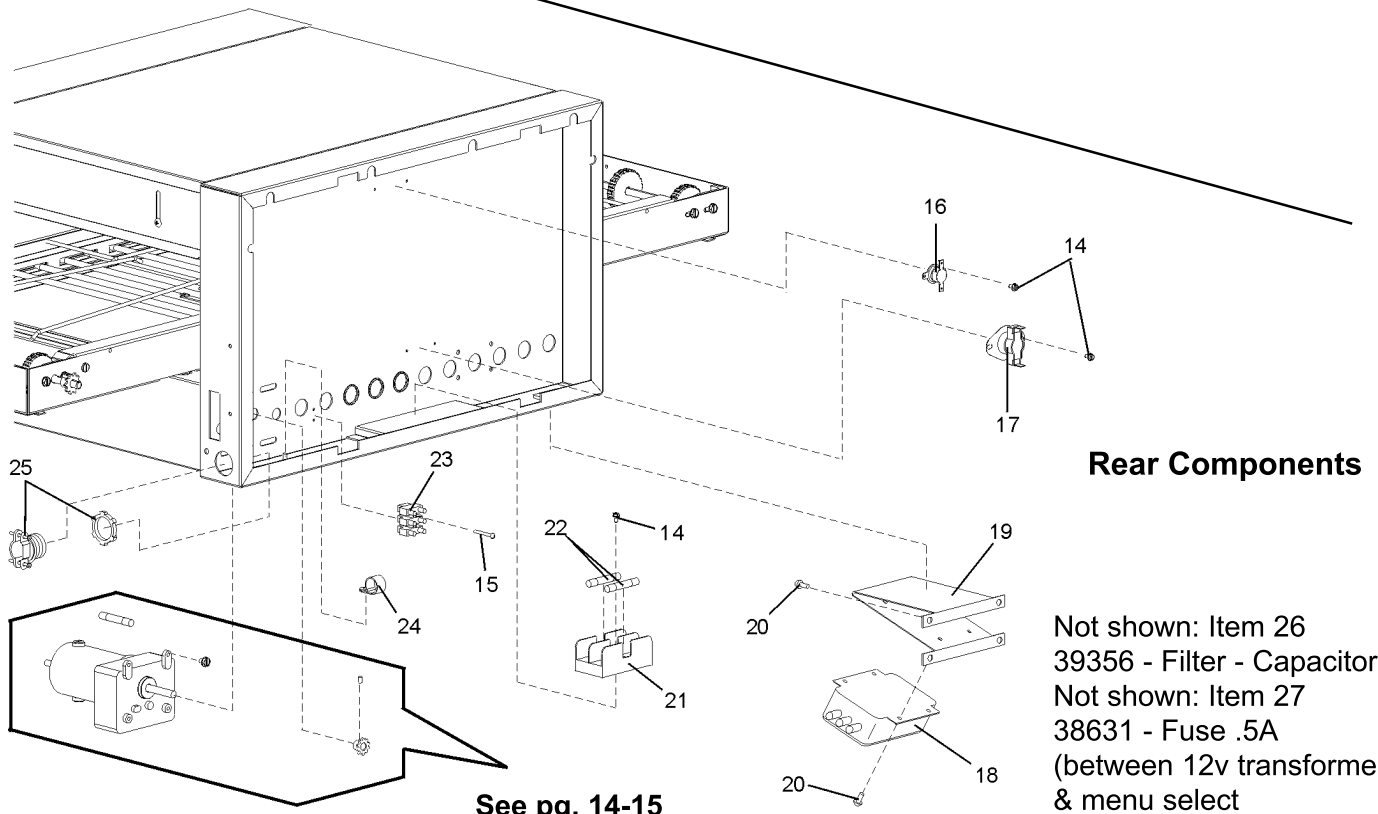
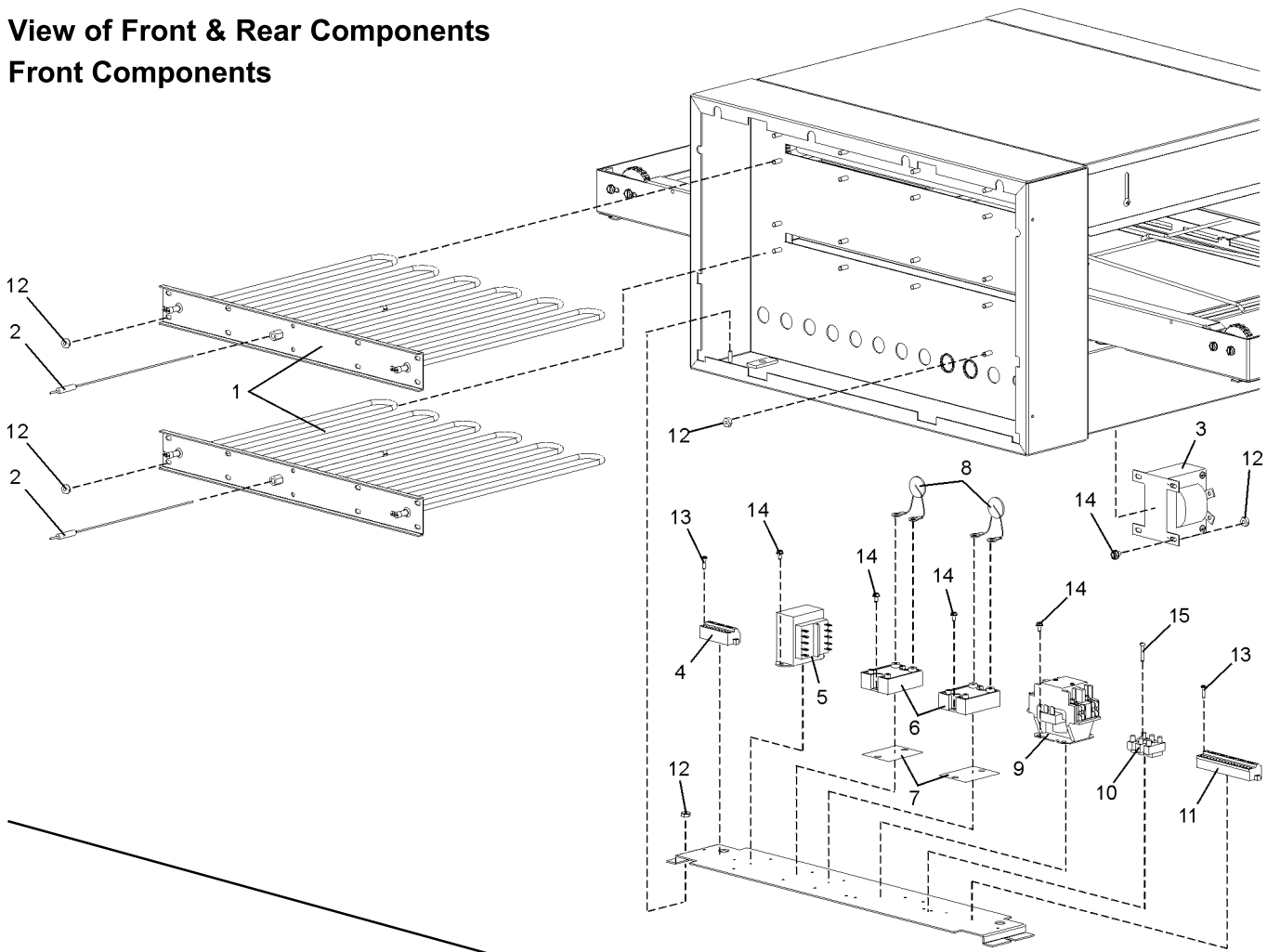

Rear Components

Not shown: Item 26
 39356 - Filter - Capacitor
 Not shown: Item 27
 38631 - Fuse .5A
 (between 12v transformer
 & menu select)

See pg. 14-15

Parts for Front & Rear Components

ITEM	P/N	QUANTITY				DESCRIPTION
		TCO21 14 (UL) 208V 50/60 Hz, 1 Ph	TCO21 14 (UL) 240V 50/60 Hz, 1 Ph	TCO21 14 (CE) 230V 50 Hz, 1 Ph	TCO21 14 (CE) 380-400V 50 Hz, 3 Ph	
1	46504	2	--	--	--	HEATER ASSEMBLY, 208V/2500W
1	46505	--	2	2	2	HEATER ASSEMBLY, 230V/2500W
2	46503	2	2	2	2	THERMOCOUPLE
3	30697	1	1	1	1	TRANSFORMER, 230V/115V 50VA
4	37351	1	1	1	1	CONNECTOR, 10-PIN FEMALE
5	35818	1	1	1	1	TRANSFORMER, 230V/12V
6	38469	2	2	2	2	SOLID STATE RELAY, 240V/25A
7	220009	2	2	2	2	GASKET, SILICON
8	3430108A	2	2	2	2	VARISTOR
9	3000639	1	1	1	--	CONTACTOR, 2-POLE 35A-208/240V
9	3000647	--	--	--	1	CONTACTOR, 4-POLE 50A
10	33406	1	1	--	--	TERMINAL BLOCK (FRONT), 3-POLE
11	37789	1	1	1	1	CONNECTOR, 17-PIN FEMALE
12	2001371	A/R	A/R	A/R	A/R	NUT, KEPS 10-32
13	3510A12	4	4	4	4	SCREW, MS SLT PAN HD 5-40 X 1/2"
14	2000023	A/R	A/R	A/R	A/R	SCREW, MS SLT HEX WSHR HD 6-32 X 1/4"
15	39004	4	4	2	2	SCREW, T/S SHLDR THB 10-32 X 3/8"
16	38079	1	1	1	1	TSTAT, SNAP DISC NO (CLOSE 250°F/121°C)
17	30519	1	1	1	1	TSTAT, SNAP DISC NC (OPEN 250°F/121°C)
18	33813	--	--	1	1	RFI FILTER
19	38688	--	--	1	1	BRACKET, RFI FILTER
20	K1DS195	--	--	8	8	SCREW, MS SLT PAN HD 5-40 X 1/4"
21	30140	1	1	1	1	FUSEBLOCK
22	28154-0009	2	2	2	2	FUSE, TYPE CC, 5A/600V
23	33406	1	1	--	--	TERMINAL BLOCK (REAR), 3-POLE
23	39258	1	1	1	1	TERMINAL BLOCK (REAR), 5-POLE
24	27276-0002	1	1	1	1	CABLE CLAMP, NYLON, 5/8"
25	31791	1	1	1	1	CABLE CLAMP, 3/4"
Not Shown:						
26	39356	--	--	--	1	FILTER - CAPACITOR
27	38631	1	1	1	1	FUSE - .5A (BETWEEN 12V TRANSFORMER & MENU SELECT
--	37350	1	1	--	--	CORD AND PLUG (NEMA 6-30P)
--	30641	--	--	1	--	CORD AND PLUG (IEC 309 STYLE)
--	38295	1	1	--	--	WIRESET (UL VERSIONS)
--	38705	--	--	1	--	WIRESET (CE 230V 1 Ph VERSION)
--	38797	--	--	--	11 1	WIRESET (CE 380-400V 3 Ph VERSION)

View of Front Panel and Control Components

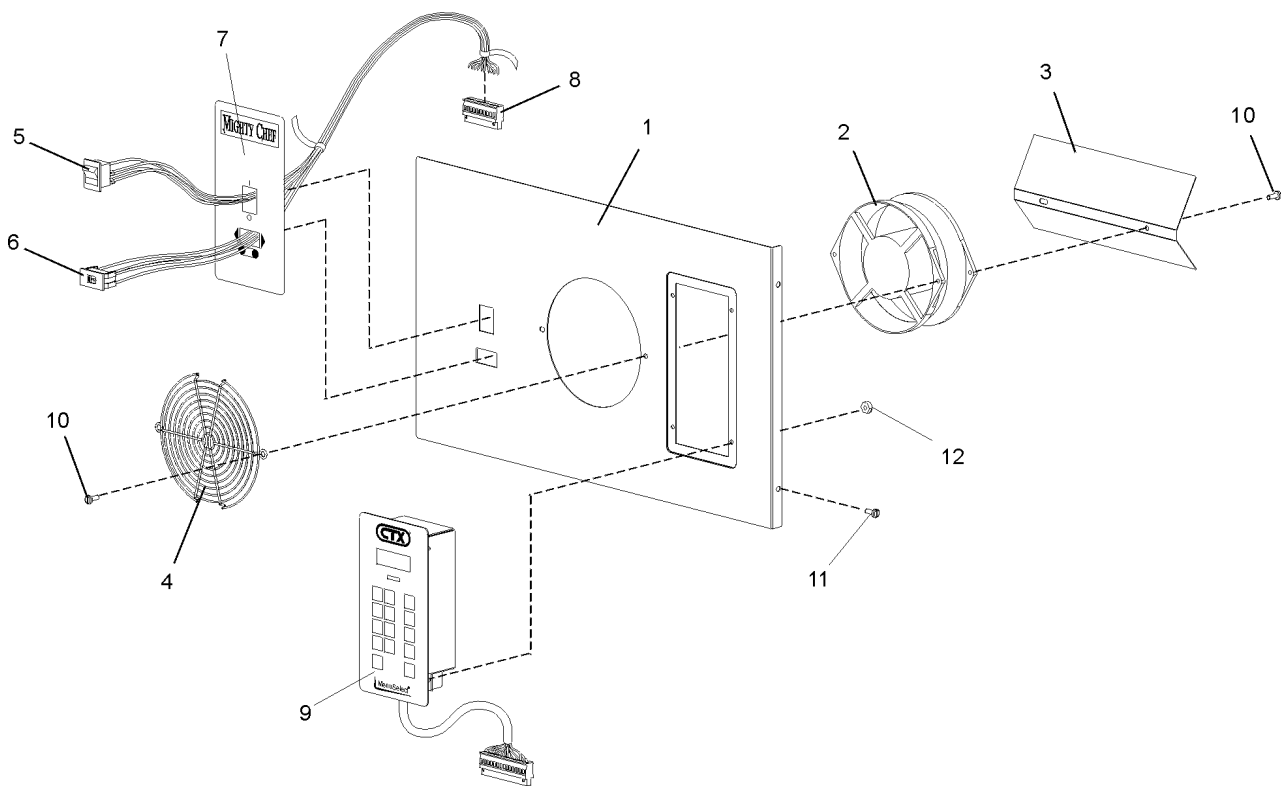

Parts for Front Panel and Control Components

ITEM	P/N	QTY.	DESCRIPTION
1	37961	1	FRONT PANEL
2	38471	1	COOLING FAN
3	38276	1	COOLING FAN AIR DEFLECTOR
4	31497	1	COOLING FAN GRILL - 6" DIAMETER
5	35824	1	POWER ON/OFF (I/O) SWITCH
6	37646	1	CONVEYOR REVERSING SWITCH
7	45402	1	DECAL, SWITCH LABELS, SELF-ADHESIVE
8	38214	1	CONNECTOR, 10-PIN MALE
9	37349	1	MENUSELECT® CONTROL
10	220282	4	SCREW, SLT TRS HD 10-32 X 1/2", BLACK
11	2000096	2	SCREW, MS SLT TRS HD 10-32 X 3/8"
12	2001347	4	NUT, KEPS 8-32

View of Conveyor System

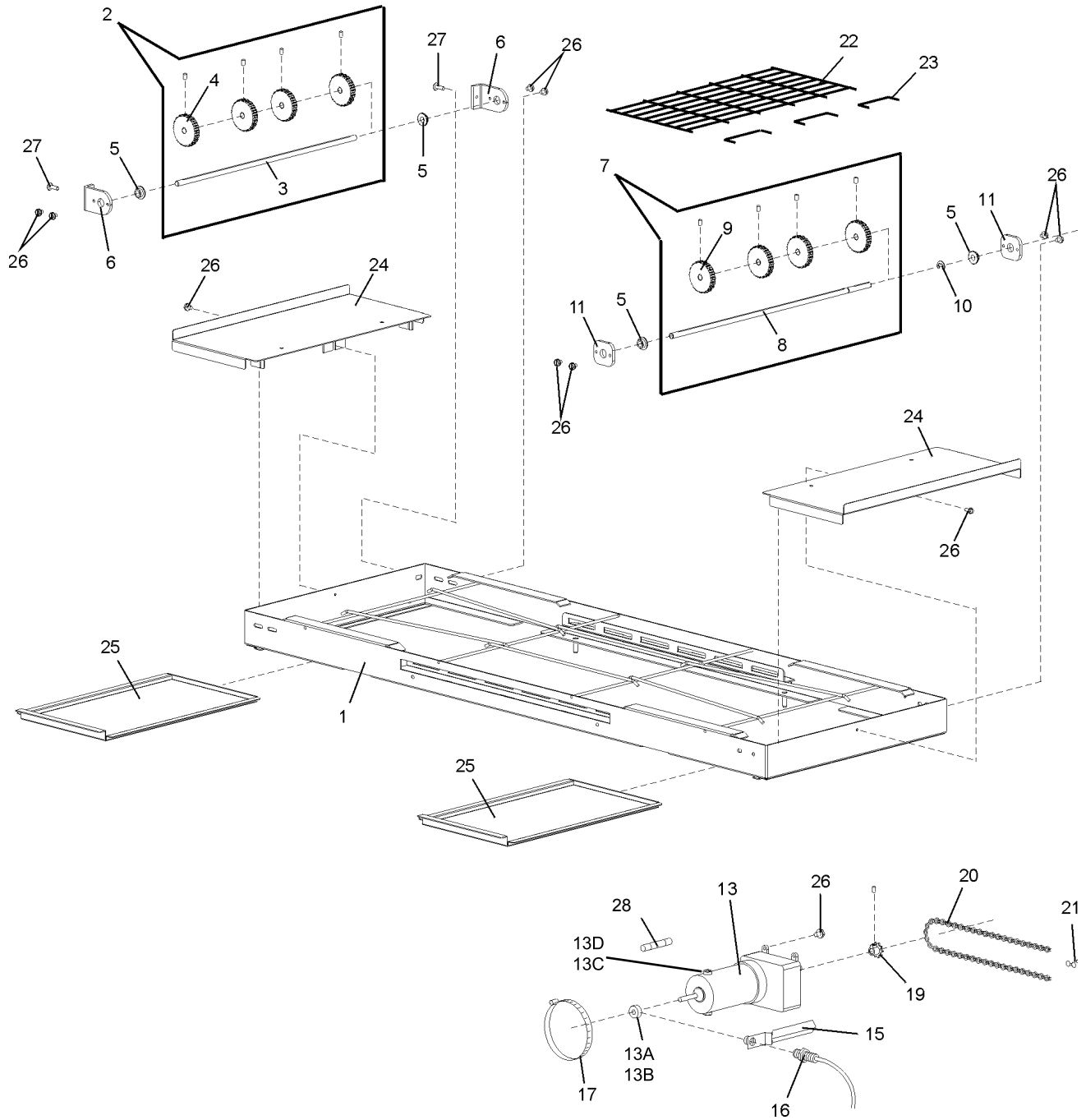

Parts for Conveyor System

ITEM	P/N	QTY.	DESCRIPTION
1	37309	1	CONVEYOR FRAME
2	37316	1	IDLER SHAFT ASSEMBLY
3	36745	1	IDLER SHAFT
4	37950	4	SPROCKET W/SET SCREW
5	36742	4	BUSHING
6	36729	2	IDLER BEARING BLOCK/TENSIONER
7	37315	1	DRIVE SHAFT ASSEMBLY
8	37314	1	DRIVE SHAFT
9	37950	4	SPROCKET W/SET SCREW
10	3102930	1	RETAINING CLIP, E-RING, 5/16"
11	36733	2	DRIVE BEARING BLOCK
12	34129	1	SPROCKET, DRIVE SHAFT, 12T W/SET SCREW
13	58390	1	MOTOR, CONVEYOR DRIVE WITH 2-POLE MAGNET
13A	39002	1	MAGNET 2-POLE
13B	310-0017	1	ADHESIVE
13C	300-2757	1	CONVEYOR DRIVE MOTOR- ONLY
13D	58484	1	KIT, 2 BRUSHES & 2 CAPS
13E	30153	1	BRUSH, SOLD INDIVIDUALLY, QTY 2 REQUIRED
15	22450-0248	1	BRACKET, SENSOR MOUNTING
16	38185	1	PICKUP SENSOR ASSEMBLY
17	220416	1	CLAMP, SENSOR MOUNTING
19	38216	1	SPROCKET, DRIVE MOTOR, 10T W/SET SCREW
20	39003	1	DRIVE CHAIN, #25, COMPLETE
21	3101212	1	MASTER LINK, #25
22	38247	1	CONVEYOR BELT, COMPLETE (7 FT./2.13m)
23	38246	3	MASTER LINK, CONVEYOR BELT
24	38257	2	END TRAY
25	36686	2	CRUMB TRAY
26	2000177	A/R	SCREW, MS SLT HEX WSHR HD 10-32 X 1/4"
27	35817	2	SCREW, TRS HD 10-32 X 5/8" SS
28	31053	1	FUSE .25A

REV	DATE	ECN	REVISION DESCRIPTION	BY	CHK	DATE
D	09/10/1998	980502	RELOCATE MOTOR WIRE ON SHT 2	RN		
E	04/21/1999	990325	ADDED 6 IN GROUND WIRE & NOTE ON SHT 2	KMH	MSS	06/21/1999
F	01/28/2006	060024	REMOVED PART NUMBERS FROM DRAWING.	KMH	MSS	01/28/2006

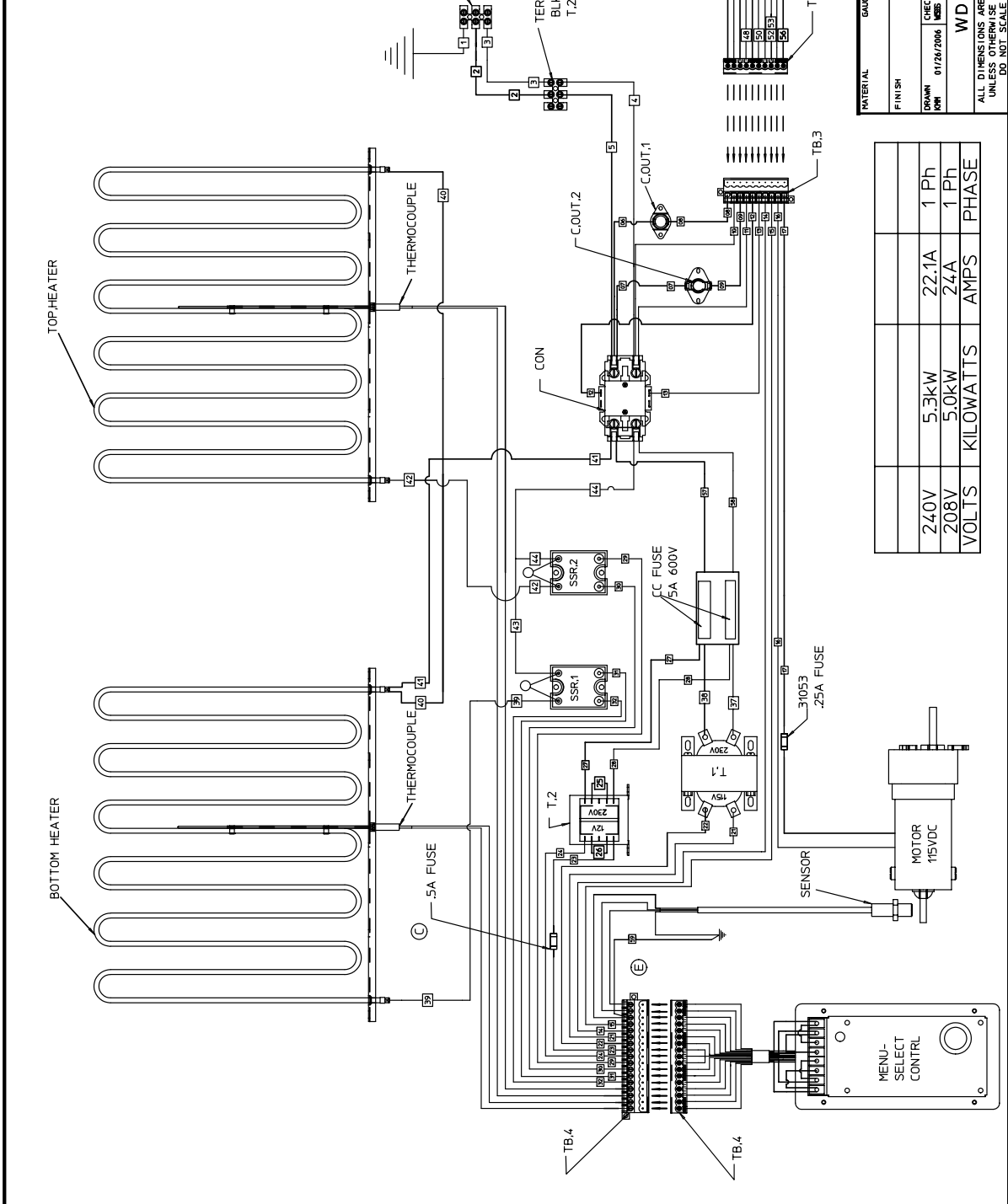

MATERIAL	Gauge:	TOLERANCE UNLESS OTHERWISE SPECIFIED	THIS DRAWING IS CONFIDENTIAL AND PROPERTY OF
FINISH		ANGLES $\pm 1.0^\circ$	THE MIDDLEBY CORPORATION
DEC		.X $\pm .030$	1400 Toaster Drive
CHECKED		.XX $\pm .015$	Elgin, Illinois 60120
01/28/2006		APPROVED	847-741-3300
MSS		MSS	01/28/2006
WD, 208V OR 240V TCO2114			
PART NO 3 8 2 4 8			SHT 1 OF 2
REV F			

240V	5.3kW	22.1A	1 Ph
208V	5.0kW	24A	1 Ph
VOLTS	KILOWATTS	AMPS	PHASE

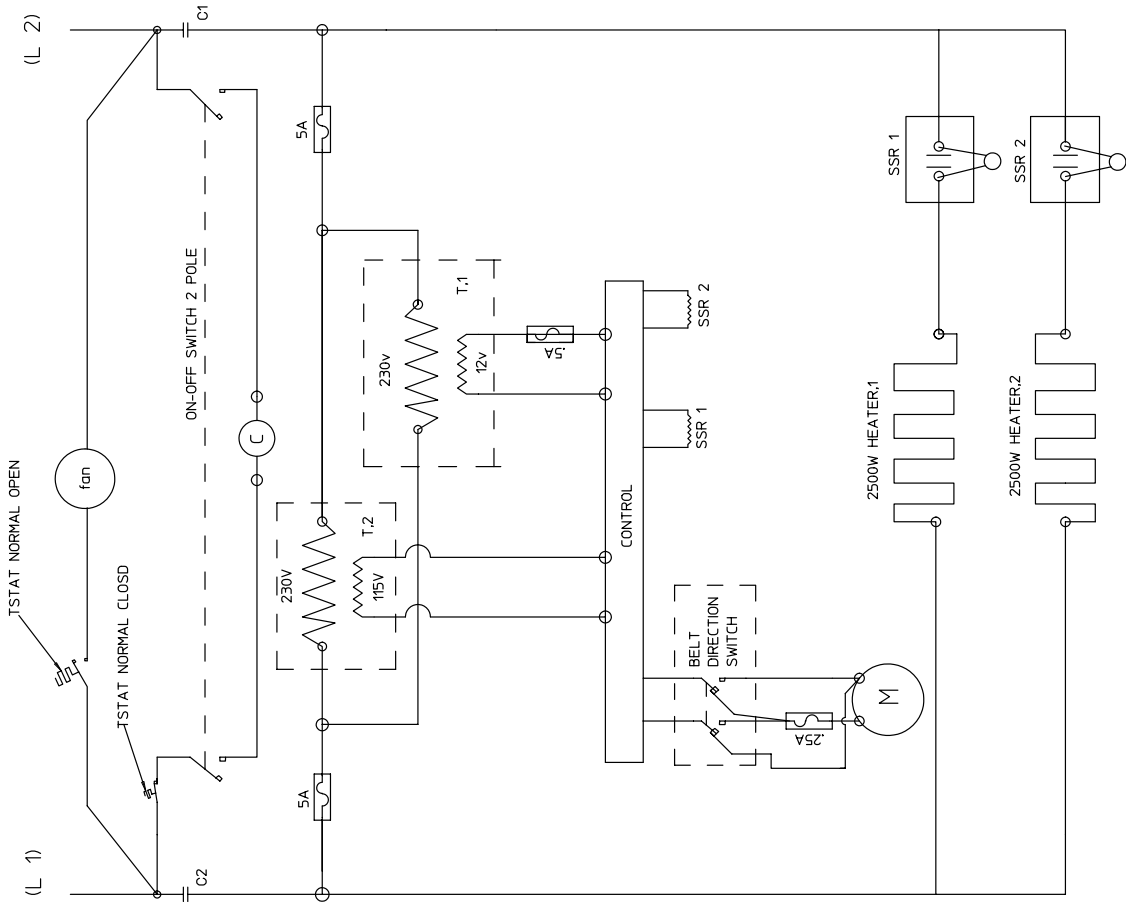

Ⓔ NOTE: WD LABEL P/N 38415

TOLERANCE UNLESS SPECIFIED: DIMENSIONS .005 ANGLES .X .030 DEC .XX .015 .XXX .005	DRAWN KMM 01/26/2006	CHECKED WSS 01/26/2006	APPROVED WSS 01/26/2006	THIS DRAWING IS CONFIDENTIAL AND PROPERTY OF THE MIDDLEBY CORPORATION 1400 Toolmaster Drive Elgin, Illinois 60120 847-741-3300
WD, 208V OR 240V TCO2114				SHT 2 OF 2
ALL DIMENSIONS ARE IN INCHES UNLESS OTHERWISE SPECIFIED. DO NOT SCALE DRAWING				REV F

REV	DATE	ECN	REVISION DESCRIPTION	BY	CHK	DATE
B	01/22/2003	003335	RELEASED FOR PRODUCTION	KMH	MS	01/02/2003
C	10/04/2003	003335A	REMOVED LANGUAGES, ADDED CORD ASSY & COLORS TO CORD LEGS.	KMH	MS	10/13/2003
D	01/26/2006	066026	REMOVED PART NUMBERS FROM DRAWING.	KMH	MS	01/26/2006

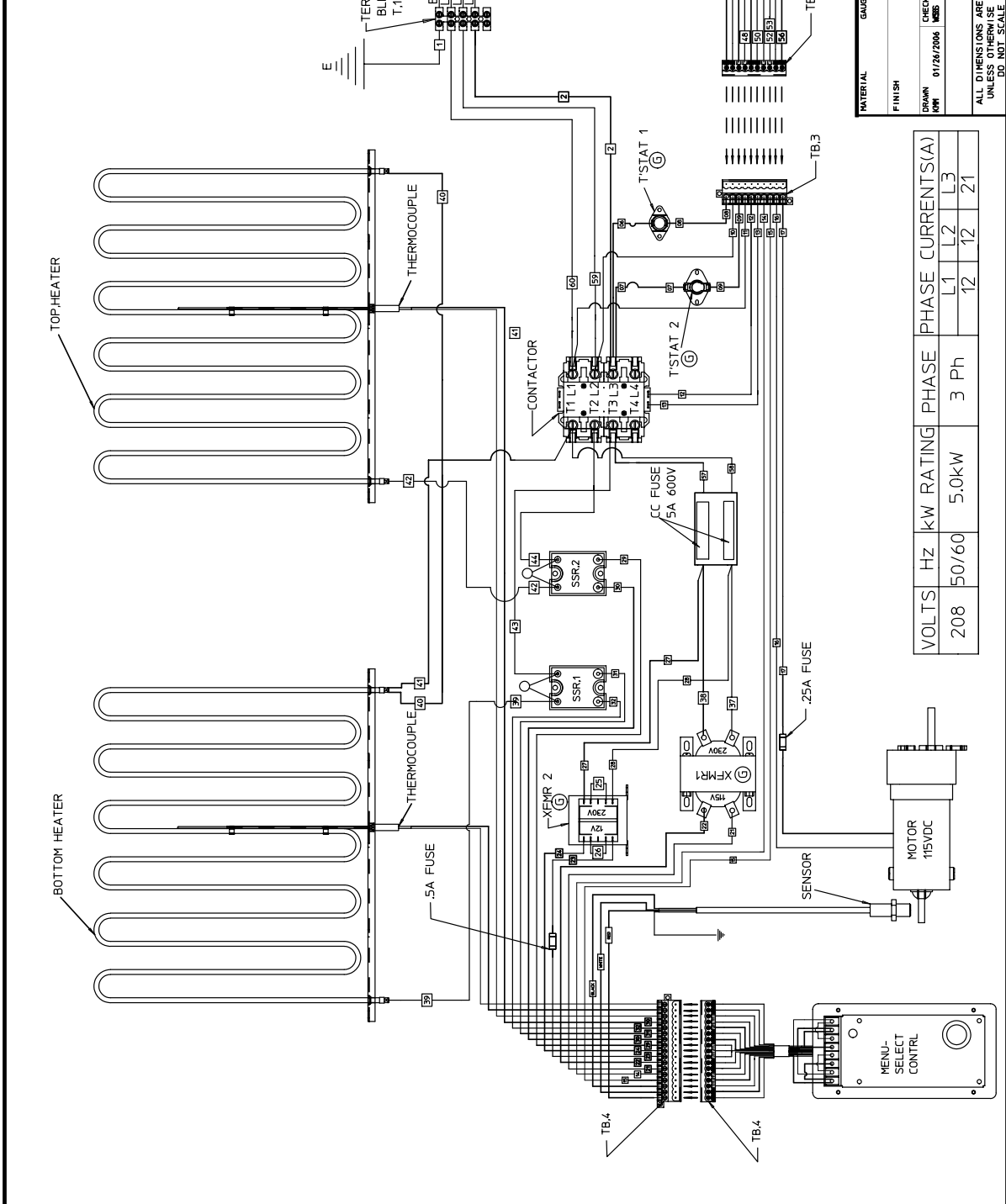

MATERIAL GAUGE:

TOLERANCE UNLESS SPECIFIED:
 ANGLES ± 1.0°
 DEC ± .015
 .XX ± .005

FINISH

DRAWN: KMH 01/26/2006
 CHECKED: MS 01/26/2006
 APPROVED: MS 01/26/2006

PROPERTY OF THE MIDDLEBY CORPORATION
 1400 Toastmaster Drive
 Elgin, Illinois 60120
 847-741-3300

WD, 208V 3PH TCO

ALL DIMENSIONS ARE IN INCHES UNLESS OTHERWISE SPECIFIED. DO NOT SCALE DRAWING.

PART NO: 51351
 SHT: 1 OF 2
 REV: D

VOLTS	HZ	kW RATING	PHASE	PHASE CURRENTS(A)
208	50/60	5.0kW	3 Ph	L1 12 L2 12 L3 21

(L 1) (L 2)

(L 3)

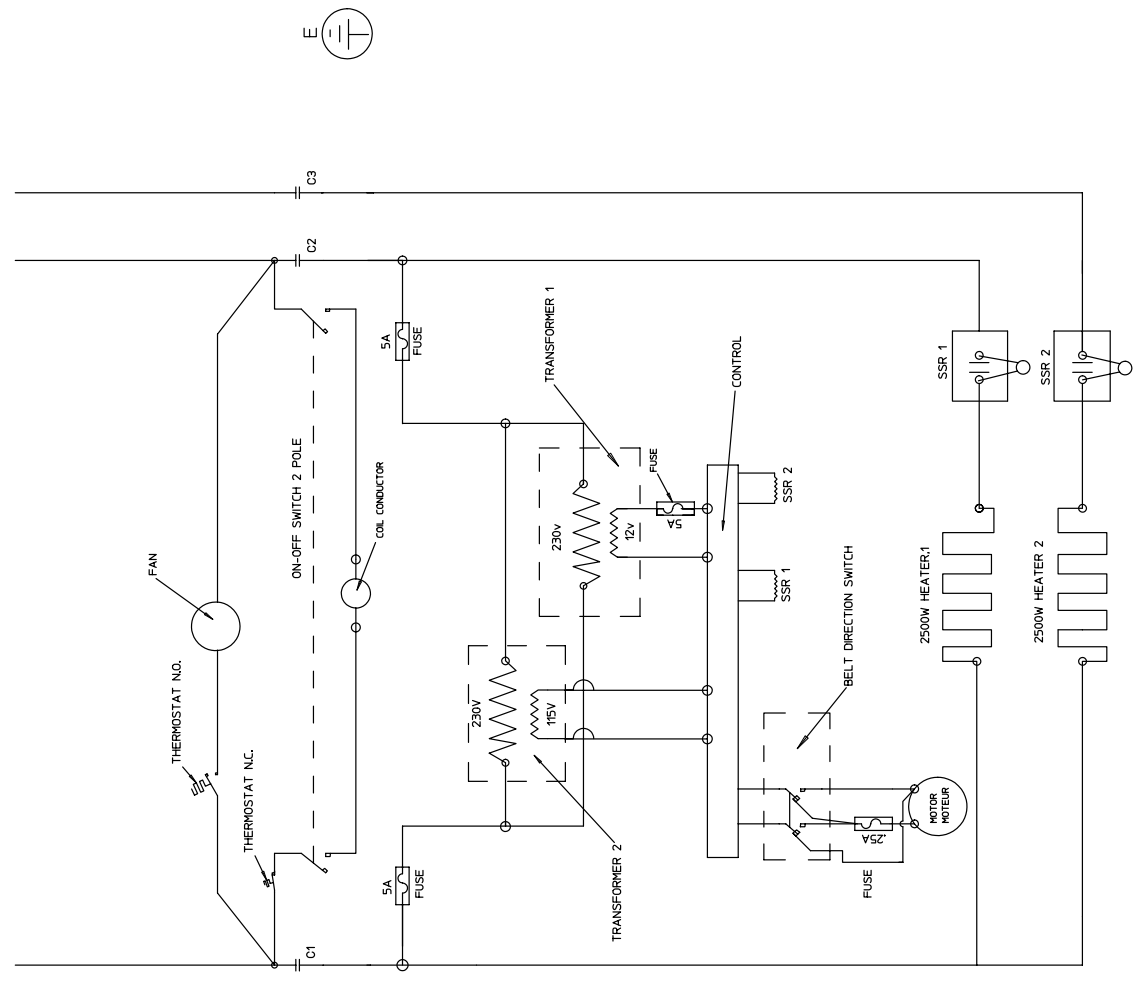

NOTE: 1) WD LABEL P/N 51561
 2) ALL WIRES TO BE #18 AWG.
 UNLESS OTHERWISE SPECIFIED.

TOLERANCES UNLESS SPECIFIED	DRAWN	DATE	THIS DRAWING IS CONFIDENTIAL AND PROPERTY OF
ANGLES ± 1.0°	KMM	01/26/2006	THE MIDDLEBY CORPORATION
DEC .X ± .030	CHECKED		1400 Toastmaster Drive
.XX ± .015	WSS	01/26/2006	Elgin, Illinois 60120
.XXX ± .005	APPROVED		847-741-3300

WD, 208V 3PH TCO
 PART NO 51351
 SHT 2 OF 2
 REV D

ALL DIMENSIONS ARE IN INCHES UNLESS OTHERWISE SPECIFIED.
 DO NOT SCALE DRAWING

REV	DATE	ECN	REVISION DESCRIPTION	BY	CHK	DATE
C	05/17/1999	990264	ADDED FRENCH, GERMAN, DUTCH & FLEMISH LANGUAGES TO PAGE 2	KHM	WSS	05/21/1999
D	06/03/1999	990292	ADDED SPANISH TO PAGE 2	KHM	WSS	04/03/1999
E	02/21/2006	066266	REMOVED PART NUMBERS FROM DRAWING	AJ		

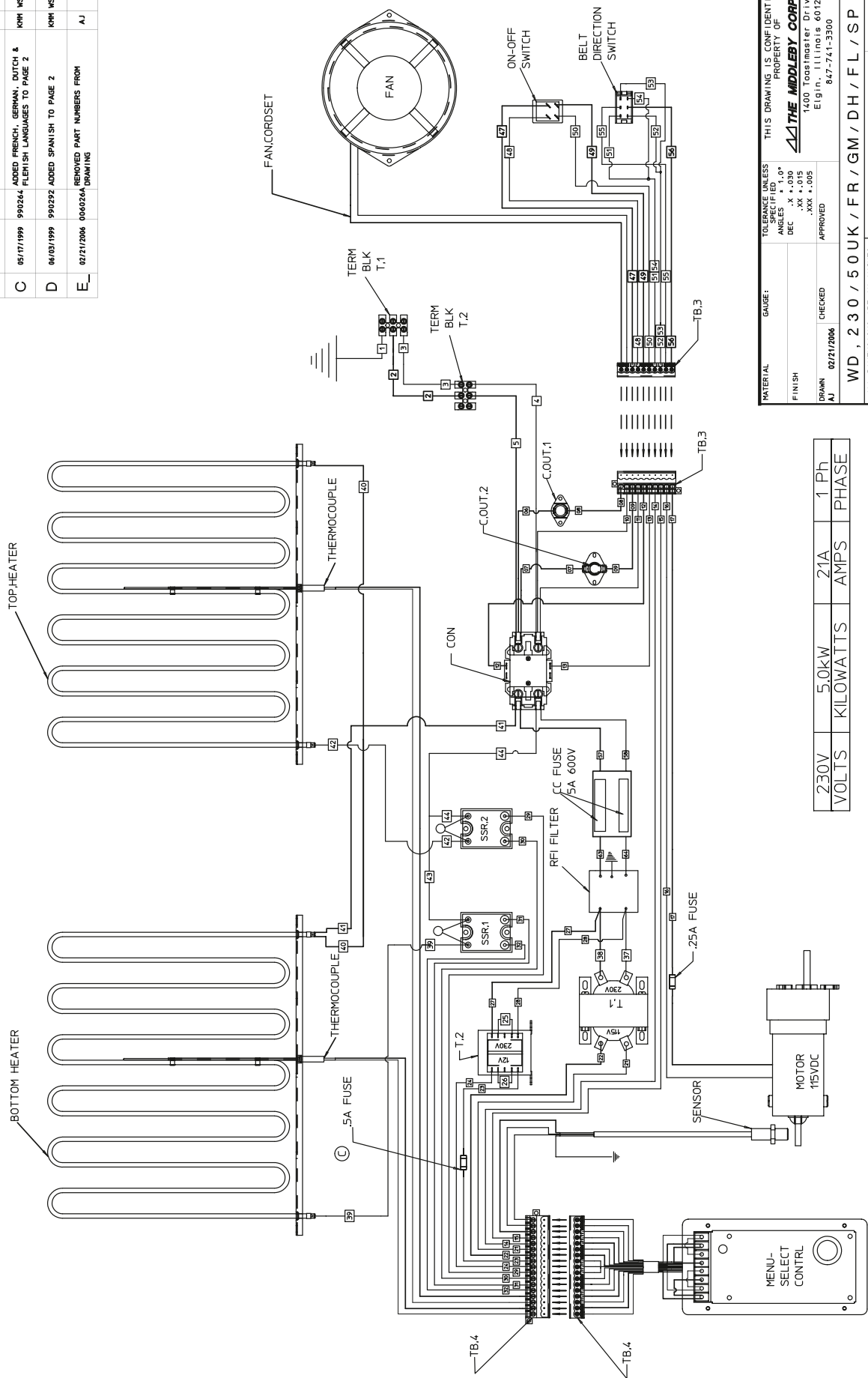

MATERIAL	GAUGE:	TOLERANCE UNLESS SPECIFIED	THIS DRAWING IS CONFIDENTIAL AND PROPERTY OF
FINISH		ANGLES ± 1.0°	THE MIDDLEBY CORPORATION
DRAWN	CHECKED	DEC .X ± .030	1400 TogaMaster Drive
AJ		XXX ± .005	Elgin, Illinois 60120
		APPROVED	847-741-3300
WD, 230 / 5.0kW / FR / GM / DH / FL / SP		PART NO	38703
ALL DIMENSIONS ARE IN INCHES UNLESS OTHERWISE SPECIFIED. DO NOT SCALE DRAWING.		SHT	1 OF 2
		REV	E-

230V	5.0kW	21A	1 Ph
VOLTS	KILOWATTS	AMPS	PHASE

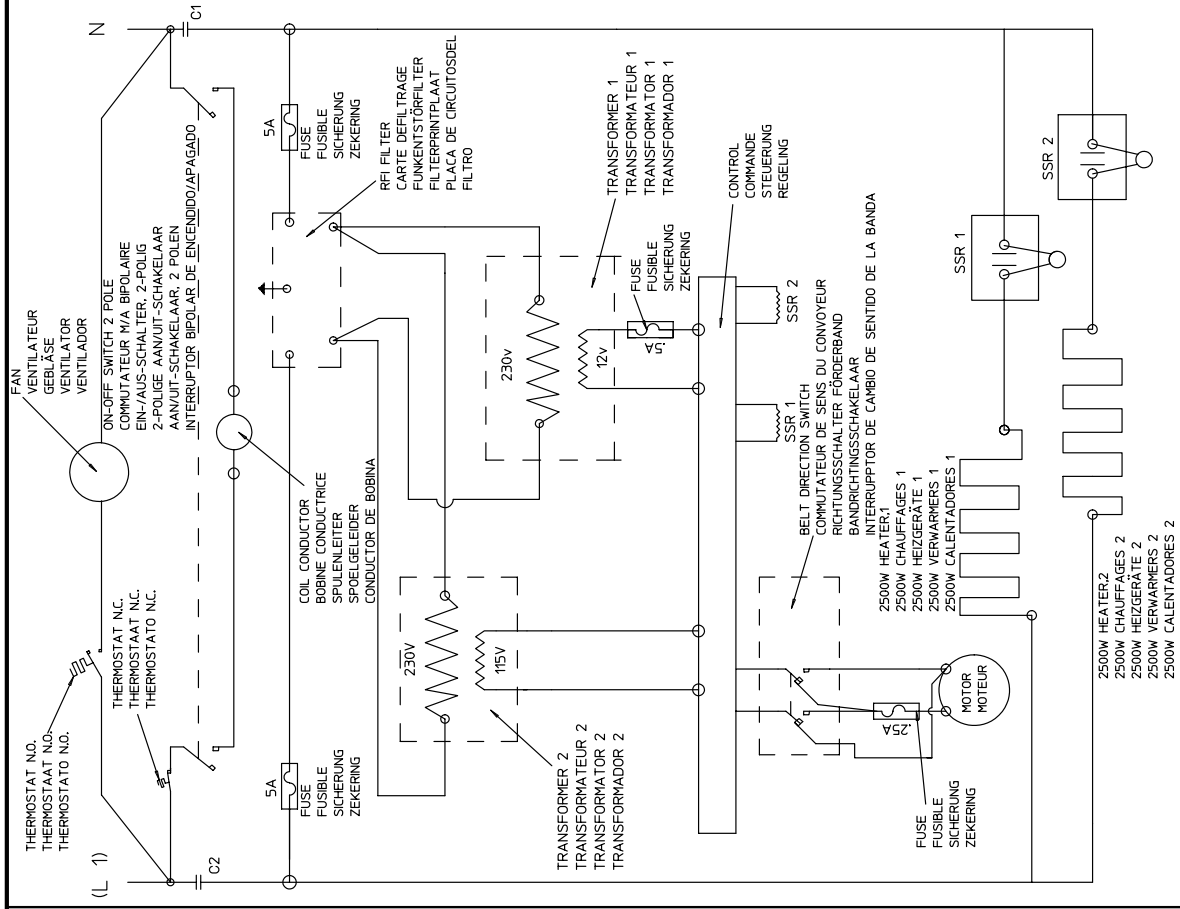

NOTE: 1) WD LABEL P/N 38704.
 2) ALL WIRES ARE TO BE #18 AWG.
 UNLESS OTHERWISE SPECIFIED.

TOLERANCE UNLESS SPECIFIED ANGLES ± 1.0° DEC .XX ± .015 .XXX ± .005	DRAWING DATE 02/21/2006 CHECKED APPROVED	THIS DRAWING IS CONFIDENTIAL AND THE PROPERTY OF THE MIDDLEBY CORPORATION 1400 Tomlinson Drive Elyria, Ohio 44120 847-741-3300
WD, 230 / 50UK / FR / GM / DH / FL / SP TCO		PART NO 38703
ALL DIMENSIONS ARE IN INCHES UNLESS OTHERWISE SPECIFIED. DO NOT SCALE DRAWING		SHEET 2 OF 2 REV E

REV	DATE	ECN	REVISION DESCRIPTION	BY	CHK	DATE
E	05/17/1999	990264	ADDED FRENCH, GERMAN, DUTCH & FLEMISH LANGUAGES TO PAGE 2	KHM	NSS	05/21/1999
F	08/21/2003	003335	CHANGED DEC. REVERSED T.1 (L1, L2, L3), REVERSED W.1 & W.2	ATH	NSS	09/02/2003
G	01/26/2006	006024	REMOVED PART NUMBERS FROM DRAWING.	KHM	NSS	01/26/2006

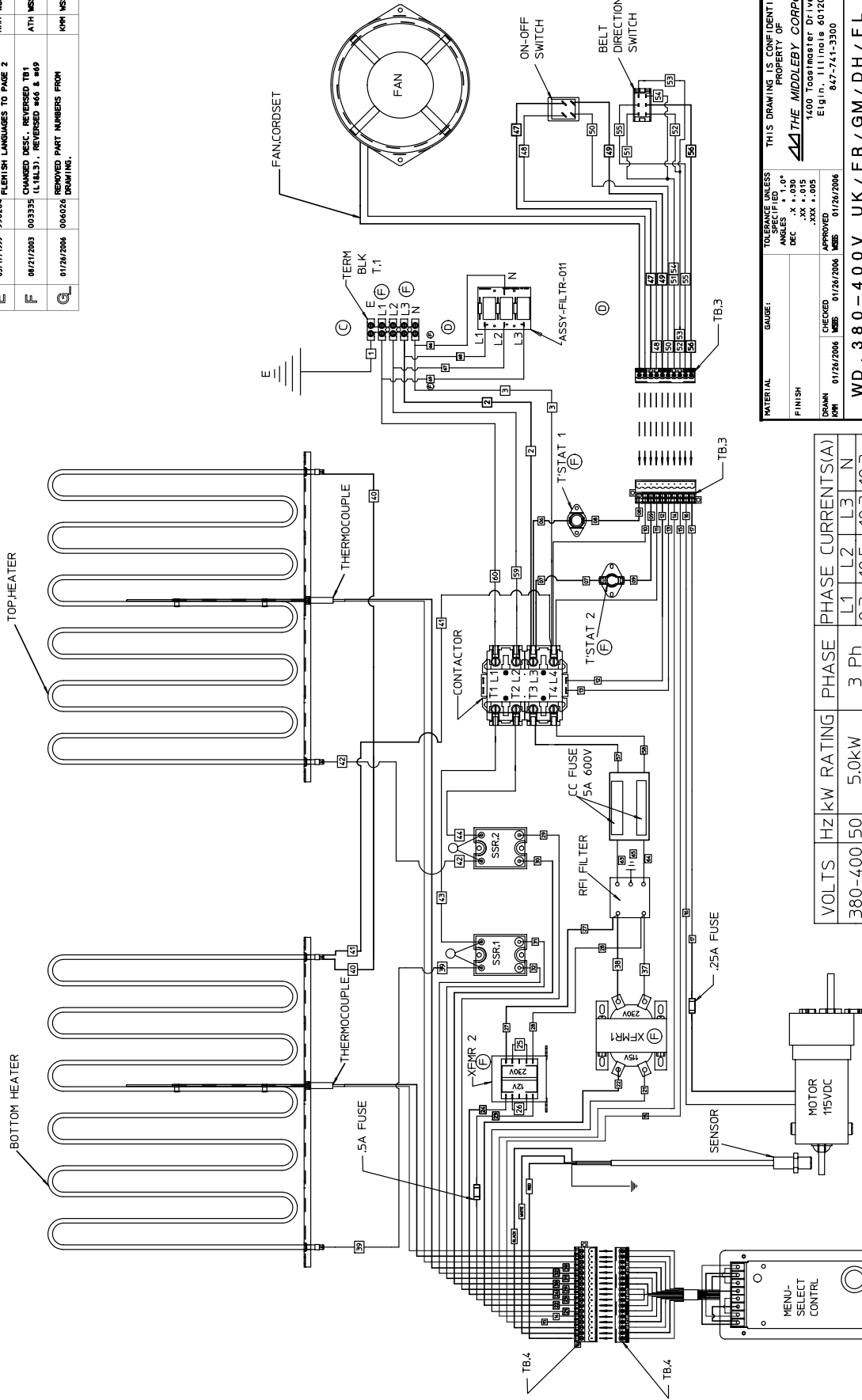

MATERIAL		FINISH		TOLERANCE UNLESS SPECIFIED					
				ANGLES 1.0°					
				DEC .X +.030					
				.XX +.015					
				.XXX +.005					
DRAWN	01/26/2006	CHECKED	01/26/2006	APPROVED	01/26/2006				
W.1		N.S.S.		N.S.S.					
WD, 380-400V UK/FR/GM/DH/FL TCO									
ALL DIMENSIONS ARE IN INCHES UNLESS OTHERWISE SPECIFIED. DO NOT SCALE DRAWING.				PART NO	38710	SHT	1 OF 2	REV	G_

VOLTS	Hz	KW RATING	PHASE	PHASE CURRENTS(A)
380-400	50	5.0kW	3 Ph	L1 L2 L3 N
				0.3 10.5 10.3 10.3

THIS DRAWING IS CONFIDENTIAL AND PROPERTY OF THE MIDDLEBY CORPORATION
 1100 TOWNSEND DRIVE
 ELGIN, ILLINOIS 60120
 847-741-3300

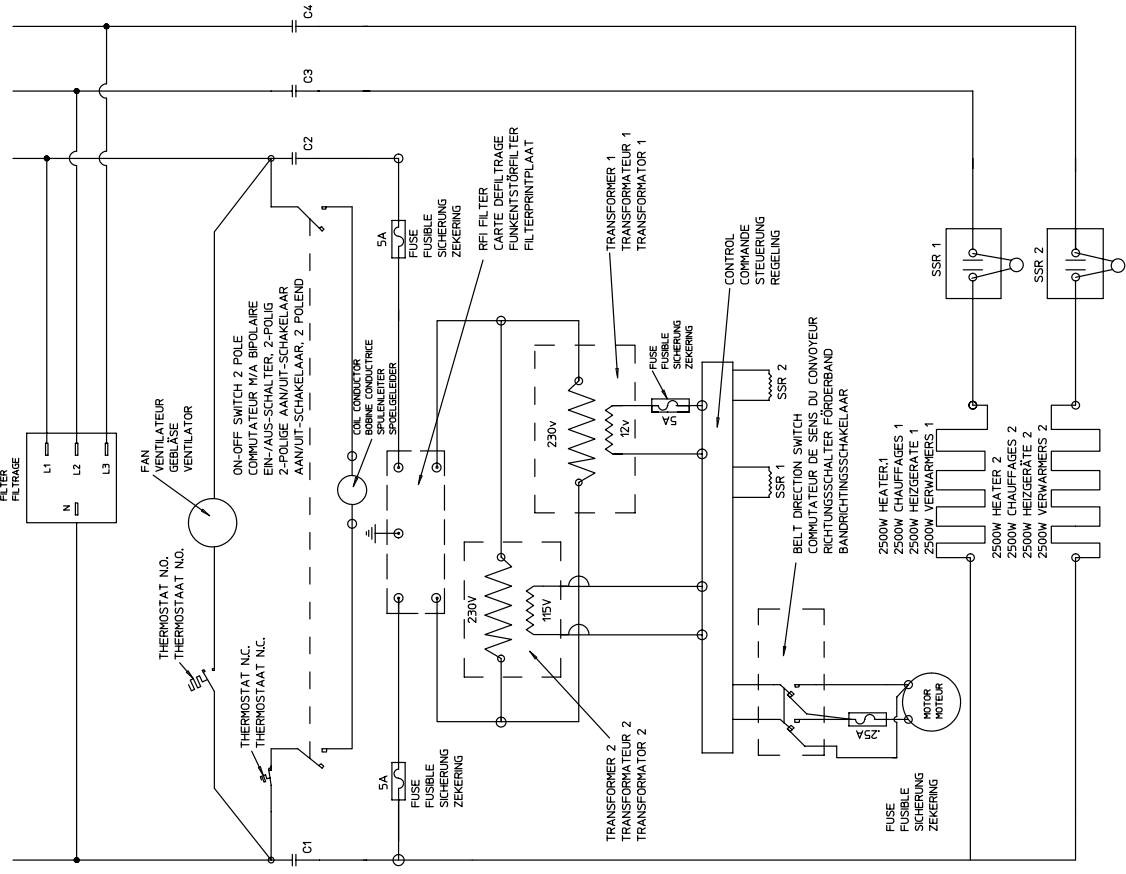

NOTE: 1) WD LABEL P/N 38713.
 2) ALL WIRES TO BE #18 AWG.
 UNLESS OTHERWISE SPECIFIED.

TOLERANCE UNLESS SPECIFIED IS		DRAWN		THIS DRAWING IS CONFIDENTIAL AND PROPERTY OF	
ANGLES	+ 1.0°	KM	01/26/2006	THE MIDDLEBY CORPORATION	
DEC	.X +.030	CHECKED		1400 Tossmeister Drive	
	.XX +.015	MSS	01/26/2006	Elgin, Illinois 60120	
	.XXX +.005	APPROVED		847-741-3300	
MSS		01/26/2006	WD, 380 - 400V UK / FR / GM / DH / FL TCO		
ALL DIMENSIONS ARE IN INCHES UNLESS OTHERWISE SPECIFIED. DO NOT SCALE DRAWING.			PART NO	38710	REV
			SHT	2 OF 2	G

