

Parts Manual

*with Wiring Diagrams
for domestic and standard export ovens*

Serial # Code (Nine Digit Code)
(for units produced prior to mid-July, 2006)
First 4 digits - order of production
Fifth digit - model specific
Sixth and Seventh digit - month of production
Eighth and Ninth digit - year of production

The X70/X55/X55GWB requires a 208/240V, 1Phase Power Supply. Therefore, the Control Circuit is 208/240V. A Modulating Gas Valve and Signal Amplifier Board were incorporated to reduce energy consumption and increase cooking efficiency. We call this our Energy Management System (EMS).

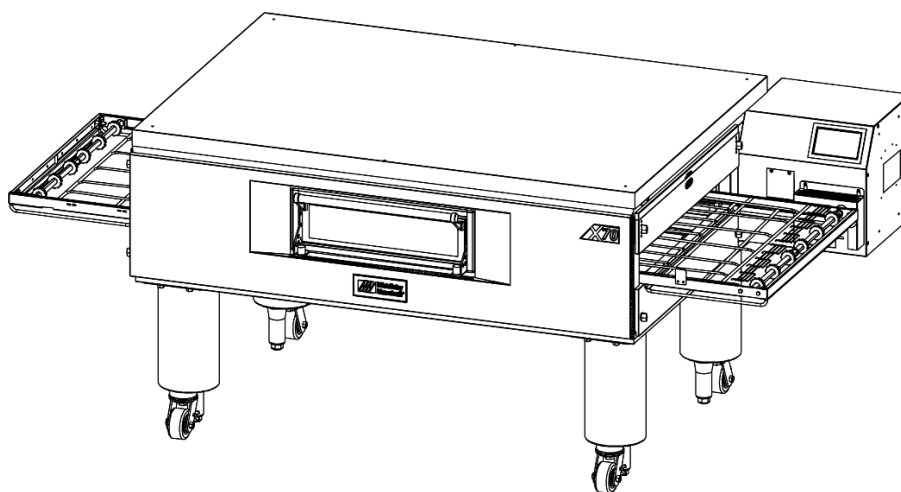

X70G Single Oven Shown

Table of Contents: Page 2

www.middleby.com

email: techsupport@middleby.com

1-847-741-3300 fax 1-847-741-4406

Table of Contents

| | |
|--|----|
| Dimension Drawings | 3 |
| Specifications | 6 |
| Key Parts | 8 |
| Installation Kits | 9 |
| Base/Top Kits | 11 |
| Parts for Base Pad Kits | 13 |
| View and Parts of BLOWER WHEELS | 16 |
| View(s) and Parts of BURNER/BLOWER ASSEMBLY | 17 |
| View of CONTROL BOX LR OT ASSEMBLY | 18 |
| Parts of CONTROL BOX LR OT ASSEMBLY..... | 19 |
| View and Parts of PHOTOEYE/BOX ASSEMBLY | 20 |
| View and Parts of MANIFOLD/PIPE ASSEMBLY..... | 21 |
| View of GAS PIPE ASSEMBLY | 22 |
| Parts for GAS PIPE ASSEMBLY | 23 |
| View of X70 SINGLE BELT CONVEYOR | 24 |
| Parts for X70 SINGLE BELT CONVEYOR | 25 |
| View of X70 SINGLE BELT CONVEYOR IDLER AND DRIVE END ASSEMBLIES | 26 |
| Parts for X70 SINGLE BELT CONVEYOR IDLER AND DRIVE END ASSEMBLIES | 27 |
| View of X70 SPLIT BELT CONVEYOR | 28 |
| Parts for X70 SPLIT BELT CONVEYOR..... | 29 |
| View of X70 SPLIT BELT CONVEYOR IDLER AND DRIVE END ASSEMBLIES | 30 |
| Parts for X70 SPLIT BELT CONVEYOR IDLER AND DRIVE END ASSEMBLIES..... | 31 |
| View of X55 SINGLE BELT CONVEYOR | 32 |
| Parts for X55 SINGLE BELT CONVEYOR | 33 |
| View of X55 SINGLE BELT CONVEYOR IDLER AND DRIVE END ASSEMBLIES | 34 |
| Parts for X55 SINGLE BELT CONVEYOR IDLER AND DRIVE END ASSEMBLIES | 35 |
| View of X55G SPLIT BELT CONVEYOR..... | 36 |
| Parts for X55G SPLIT BELT CONVEYOR..... | 37 |
| View of X55G SPLIT BELT CONVEYOR IDLER AND DRIVE END ASSEMBLIES..... | 38 |
| Parts for X55G SPLIT BELT CONVEYOR IDLER AND DRIVE END ASSEMBLIES..... | 39 |
| View of X55WB CONVEYOR SPLIT BELT..... | 40 |
| Parts for X55WB CONVEYOR SPLIT BELT..... | 41 |
| View of X55WB CONVEYOR SPLIT BELT IDLER AND DRIVE END ASSEMBLIES..... | 42 |
| Parts for X55WB CONVEYOR SPLIT BELT IDLER AND DRIVE END ASSEMBLIES..... | 43 |
| View of X55WB CONVEYOR SINGLE BELT | 44 |
| Parts for X55WB CONVEYOR SINGLE BELT..... | 45 |
| View of X55WB CONVEYOR SINGLE BELT IDLER AND DRIVE END ASSEMBLIES | 46 |
| Parts for X55WB CONVEYOR SINGLE BELT IDLER AND DRIVE END ASSEMBLIES..... | 47 |
| View of X55 70/30 SPLIT BELT CONVEYOR | 48 |
| Parts for X55 70/30 SPLIT BELT CONVEYOR..... | 49 |
| View of X55 70/30 SPLIT BELT CONVEYOR IDLER AND DRIVE END ASSEMBLIES | 50 |
| Parts for X55 70/30 SPLIT BELT CONVEYOR IDLER AND DRIVE END ASSEMBLIES..... | 51 |
| MIDDLEBY MARSHALL X70G WIRING DIAGRAM G208-240 volt 50/60 Hz, 1 Phase | 52 |
| MIDDLEBY MARSHALL X55G/X55GWB WIRING DIAGRAM G208-240 volt 50/60 Hz, 1 Phase | 53 |

X70G Series Direct Gas Fired Conveyor Oven

NOTE: Drawings show ovens equipped with casters.

X70G Single Oven

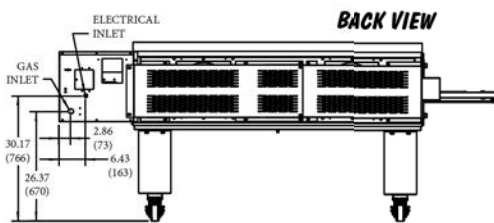
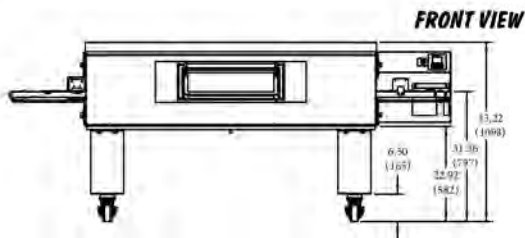
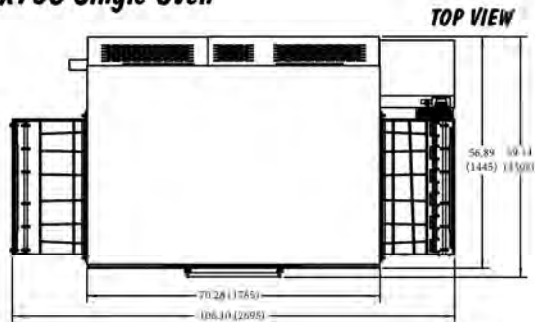

X70G Double Oven

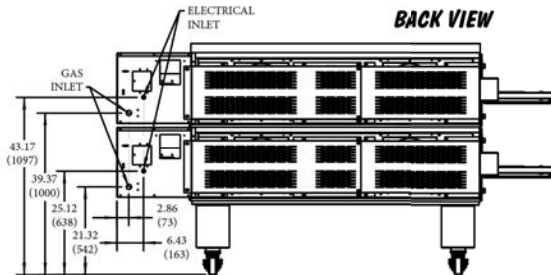
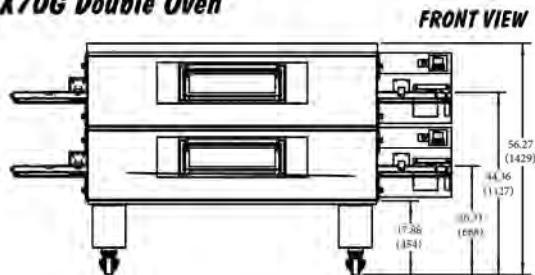

X70G Triple Oven

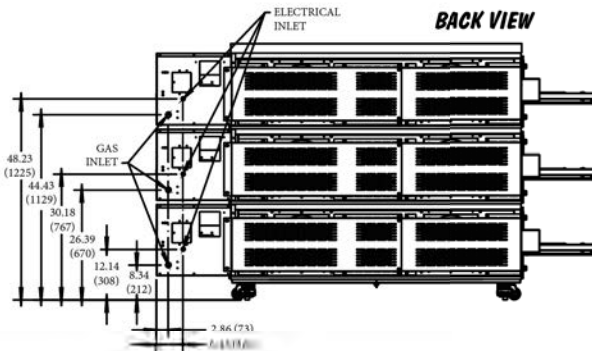
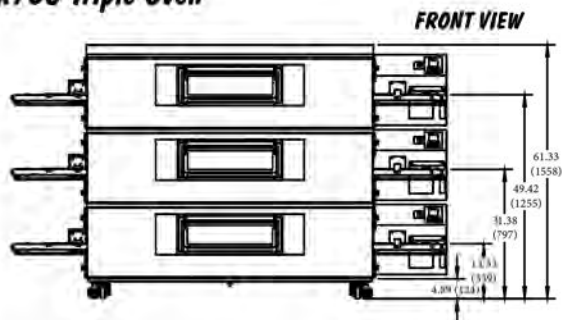

X55G Series Direct Gas Fired Conveyor Oven

NOTE: Drawings show ovens equipped with casters.

X55G Single Oven

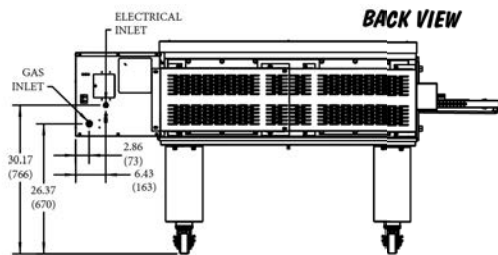
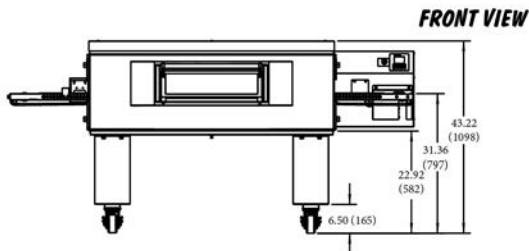
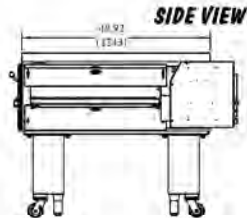
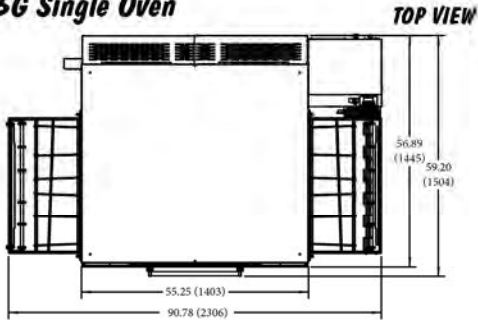

X55G Double Oven

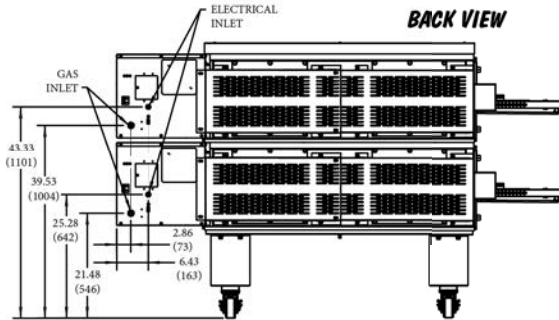
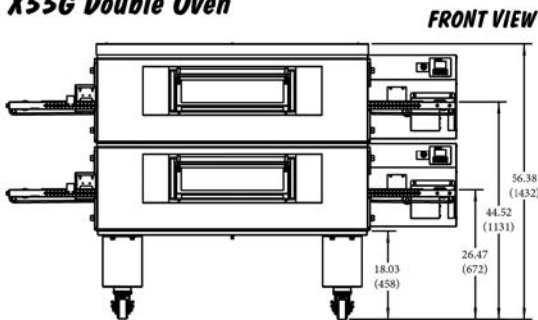

X55G Triple Oven

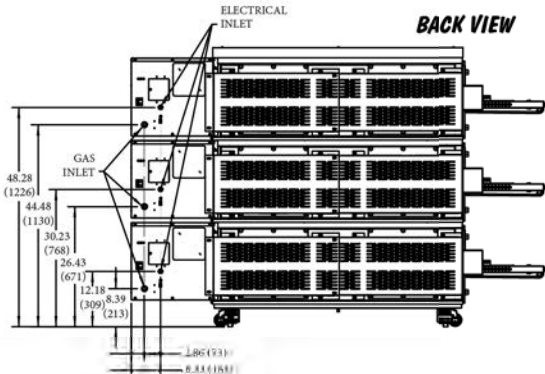
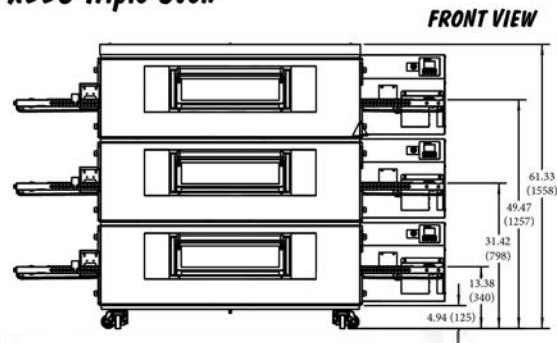

X55GWB Series Direct Gas Fired Conveyor Oven

NOTE: Drawings show ovens equipped with casters.

X55GWB Single Oven

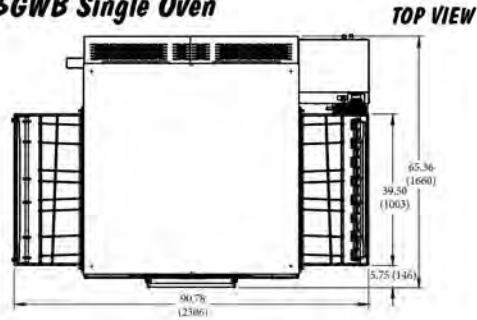

SIDE VIEW

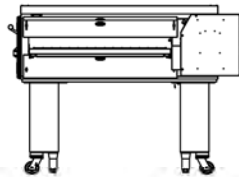

FRONT VIEW

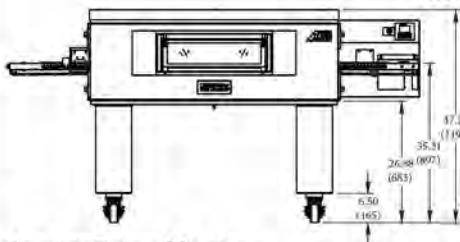

BACK VIEW

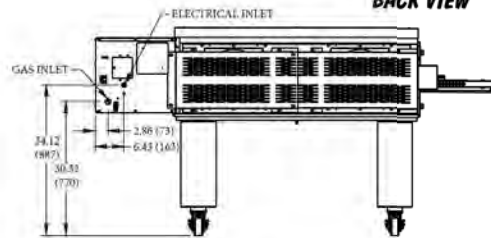

X55GWB Double Oven

FRONT VIEW

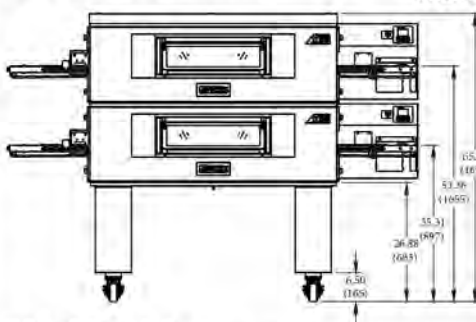

BACK VIEW

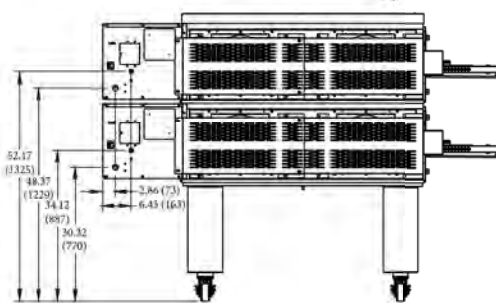

X55GWB Triple Oven

FRONT VIEW

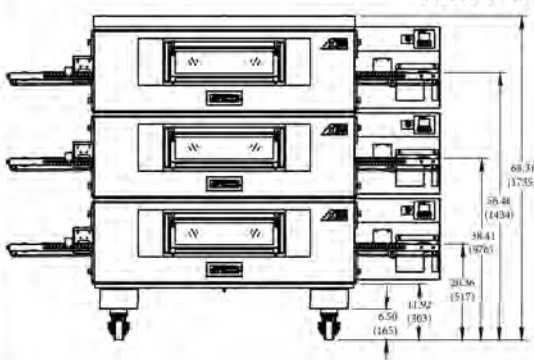

BACK VIEW

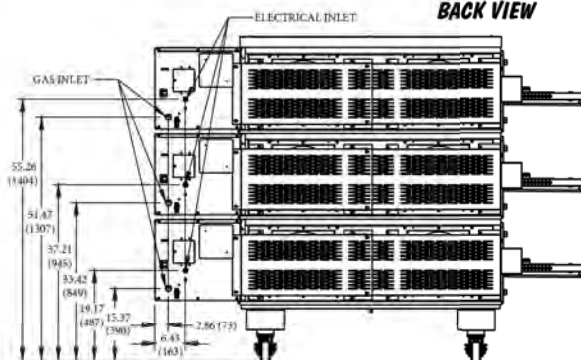

X70G/X55G SERIES Gas Conveyor Oven

RECOMMENDED MINIMUM CLEARANCES

| <i>Rear of Oven to Wall</i> | <i>Control end of Conveyor to Wall</i> | <i>Non-control end of Conveyor to Wall</i> |
|---------------------------------|--|--|
| 6" (152 mm) | 6" (152 mm) | 6" (152 mm) |

GENERAL INFORMATION

| Model | Heating Zone | Baking Area | Max. Operating Temp. | Bake Time Range | Ship Wt. | Ship Cube |
|-------|---------------|--|----------------------|-----------------|------------------------|--|
| X70G | 70" (1778 mm) | 15.6 ft ² (1.4 m ²) | 600°F (315°C) | 1 – 19 minutes | 1,415 lbs. (648 kg) | 98"L x 35"W x 74"H (2489 x 889 x 1880 mm) |
| X55G | 55" (1379 mm) | 12.2 ft ² (1.1 m ²) | 600°F (315°C) | 1 – 19 minutes | 1,290 lbs. (585 kg) | 98"L x 35"W x 74"H (2489 x 889 x 1880 mm) |

X70G/X55G SERIES OVEN SPECIFICATIONS

| <i>Dimensions</i> | <i>Single Oven</i> | <i>Double Oven</i> | <i>Triple Oven</i> |
|-------------------|---------------------|---------------------|---------------------|
| Overall Height | 43.25" (1,131 mm) | 56.27" (1,575 mm) | 68.31" (1,753 mm) |
| Overall Depth | 59.14" (1,690 mm) | 59.14" (1,690 mm) | 59.14" (1,690 mm) |
| Overall Length | | | |
| X70 | 106.1" (2,692 mm) | 106.1" (2,692 mm) | 106.1" (2,692 mm) |
| X55 | 90.78" (2,305.8 mm) | 90.78" (2,305.8 mm) | 90.78" (2,305.8 mm) |
| Conveyor Width | 32" (813 mm) | 32" (813 mm) | 32" (813 mm) |

ELECTRICAL SPECIFICATIONS

| <i>Main Blower</i> | <i>Control Circuit</i> | | | | | | |
|--------------------|------------------------|--------------|------------------|----------------------|--------------|--------------------------|-------------------|
| <i>Voltage</i> | <i>Voltage</i> | <i>Phase</i> | <i>Frequency</i> | <i>Current Draw*</i> | <i>Poles</i> | <i>Wires</i> | <i>Breakers</i> |
| 208-240VAC | 24VDC | 1 | 50/60 Hz | 12 Amps | 2 | 3 Wire (2 hot, 1 ground) | As per local code |

* The current draw ratings shown above are maximum values at startup. The average current draw during operation is significantly lower.

GAS SUPPLY SPECIFICATIONS

| <i>Gas Type</i> | <i>Inlet Pressure**</i> | <i>Manifold Pressure</i> | <i>Rated Heat Input</i> | <i>Main Orifice Diameter**</i> | <i>Fixed Bypass Orifices**</i> |
|-----------------|----------------------------|--------------------------|-------------------------------|-----------------------------------|------------------------------------|
| Natural | | | | | |
| X70 | 8-12" W.C. (20-30 mbar) | 3.5" W.C. (8.7 mbar) | 160,000 BTU/hr (46.89 kWh) | 0.1654" (4.2 mm) Dia. | #46 Drill – 0.081" (2.057 mm) Dia. |
| X55 | 8-12" W.C. (20-30 mbar) | 3.5" W.C. (8.7 mbar) | 140,000 BTU/hr (42.5 kWh) | #24 Drill – 0.152" (3.86 mm) Dia. | #46 Drill – 0.081" (2.057 mm) Dia. |
| Propane | | | | | |
| X70 | 8-12" W.C. (20-30 mbar) | 6.0" W.C. (14.9 mbar) | 160,000 BTU/hr (46.89 kWh) | #32 Drill – 0.116" (2.95 mm) Dia. | #53 Drill – 0.059" (1.49 mm) Dia. |
| X55 | 8-12" W.C. (20-30 mbar) | 6.0" W.C. (14.9 mbar) | 140,000 BTU/hr (42.5 kWh) | #36 Drill – 0.1065" (2.7 mm) Dia. | #53 Drill – 0.059" (1.49 mm) Dia. |

** The gas supply pressures and orifice sizes shown are for ovens installed in North America. The required gas supply pressures and orifice sizes of ovens installed in other locations are dependent on the local gas type and on all applicable local codes.

ALL SPECIFICATIONS SUBJECT TO CHANGE WITHOUT NOTICE

X55GWB SERIES Gas Conveyor Oven

RECOMMENDED MINIMUM CLEARANCES

| <i>Rear of Oven to Wall</i> | <i>Control end of Conveyor to Wall</i> | <i>Non-control end of Conveyor to Wall</i> |
|---------------------------------|--|--|
| 6" (152 mm) | 6" (152 mm) | 6" (152 mm) |

GENERAL INFORMATION

| Model | Heating Zone | Baking Area | Belt Length | Belt Width | Depth | Height | Max. Operating Temp. | Bake Time Range | Ship Wt. | Ship Cube |
|--------|------------------|---|---------------------|-----------------|---------------------|---------------------|----------------------|-------------------|------------------------|--|
| X55GWB | 55" (1379 mm) | 12.2 ft ² (1.1 m ²) | 90.78" (2306 mm) | 38" (965 mm) | 59.20" (1504 mm) | 43.22" (1098 mm) | 600°F (315°C) | 1 – 19 minutes | 1,349 lbs. (612 kg) | 98"L x 35"W x 74"H (2489 x 889 x 1880 mm) |

ELECTRICAL SPECIFICATIONS

| Main Blower Voltage | Control Circuit Voltage | Phase | Frequency | Current Draw* | Poles | Wires | Breakers |
|---------------------|-------------------------|-------|-----------|---------------|-------|--------------------------|-------------------|
| 208-240VAC | 24VDC | 1 | 50/60 Hz | 15 Amps | 2 | 3 Wire (2 hot, 1 ground) | As per local code |

* The current draw rating shown above are maximum values for normal operation, amperage draw will be less than the listed value. The required gas supply pressures of other locations are dependent on the local gas type and on all applicable local codes.

GAS SUPPLY SPECIFICATIONS

| Gas Type | Inlet Pressure** | Manifold Pressure | Rated Heat Input | Main Orifice Diameter** | Fixed Bypass Orifices** |
|----------|-----------------------------|--------------------------|-------------------------------|--|---|
| Natural | 6-12" W.C. (15-30 mbar) | 3.5" W.C. (8.7 mbar) | 160,000 BTU/HR (46.89 kWh) | #24 Drill – 0.152" (3.86 mm) Dia. P/N 76978 | #46 Drill – 0.081" (2.057 mm) Dia. P/N 49951 |
| Propane | 11-14" W.C. (27-35 mbar) | 6.0" W.C. (14.9 mbar) | 160,000 BTU/HR (46.89 kWh) | #36 Drill – 0.1065" (2.7 mm) Dia. P/N 77272 | #53 Drill – 0.059" (1.49 mm) Dia. P/N 22174-0006 |

** The gas supply pressures and orifice sizes shown are for ovens installed in North America. The required gas supply pressures and orifice sizes of ovens installed in other locations are dependent on the local gas type and on all applicable local codes.

Minimum Gas Pipe Sizes:

Natural Gas - 2" (50.8 mm) main supply line. One 3/4" (19 mm) NPT branch per oven cavity with individual full-flow shutoff valve.

Propane Gas - 2" (50.8 mm) main supply line. One 3/4" (19 mm) NPT branch per oven cavity with individual full-flow shutoff valve.

NOTE: Each oven includes (1) 3/4" (19 mm) NPT x 48" (1219 mm) flexible, vinyl coated gas hose, EXCEPT for CE Countries.

ALL SPECIFICATIONS SUBJECT TO CHANGE WITHOUT NOTICE

KEY PARTS

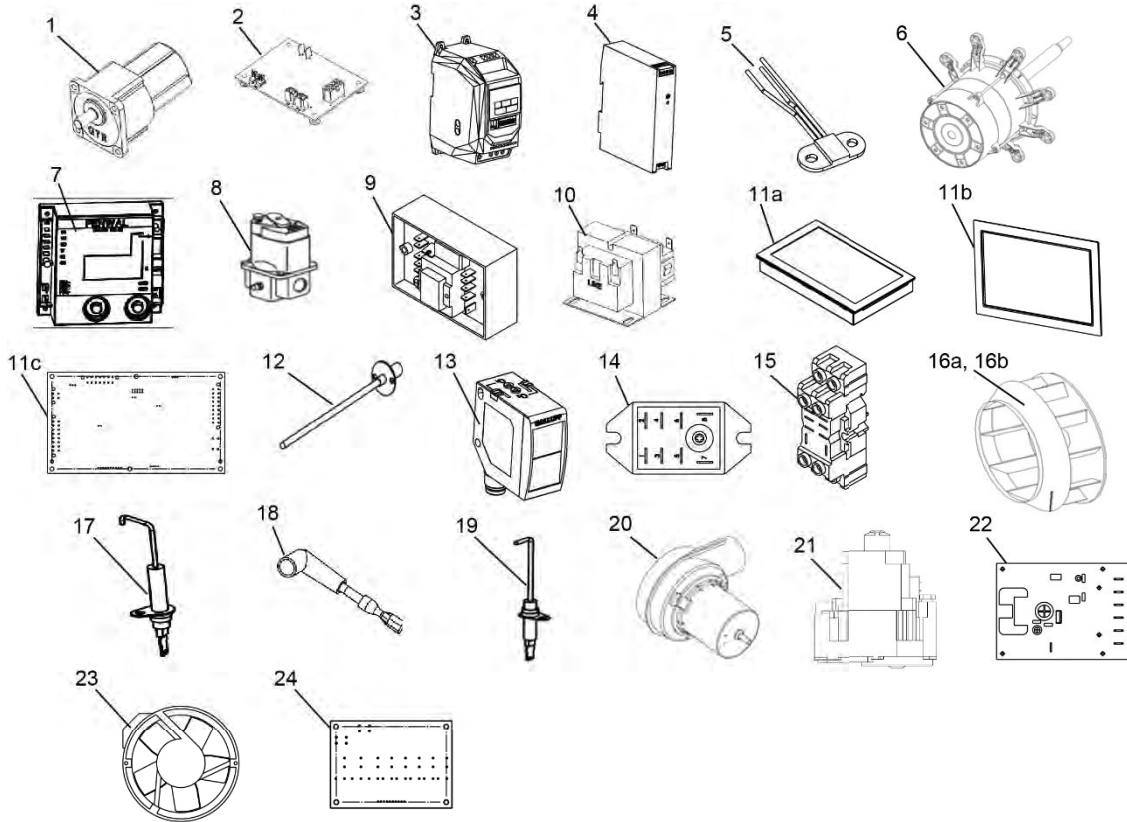

| ITEM | PART NO. | DESCRIPTION | QUANTITY |
|------|----------|---|----------|
| 1 | 74106 | Motor, Conveyor Drive | 1 or 2 |
| 2 | 77277 | Conveyor Control Board | 1 or 2 |
| 3 | 74097 | Inverter, 2HP (230V Input) | 2 |
| 4 | 76979 | Power Supply, 24VDC, 120W | 1 |
| 5 | 71421 | Rotation Sensor, Hamlin (For Burner Blower Motor) | 1 |
| 6 | 76118 | Blower Motor, 1 HP Havantic | 2 |
| 7 | 78218 | Dual Ignition Module | 1 |
| 8 | 59450 | Modulating Gas Valve | 1 |
| 9 | 33983 | Hi Limit Control Module 240V | 1 |
| 10 | 32108 | Transformer, 240 Primary/24 Secondary | 2 |
| 11 A | 79324 | One Touch Control | 1 |
| 11 B | 77764 | MLUI Bezel | 1 |
| 11 C | 77275 | Main I/O Board | 1 |
| 12 | 33812-11 | 8-1/2" Thermocouple, Grounded (5 per oven) | 6 |
| 13 | 72209 | Photo Sensor | 1 |
| 14 | 60952 | 240VAC Coil, 10A Relay | 1 |
| 15 | 77020 | Socket, Din Rail Relay IDEC | 1 |
| 16 A | 76888 | CW Blower Wheel 12 - 1/4 12 BLD | 1 |
| 16 B | 76887 | CCW Blower Wheel 12 - 1/4 12 BLD | 1 |
| 17 | 69855 | Igniter, Single Rod | 1 |
| 18 | 77422 | Ignition Cable, Wireset, X70/X55 = 60" | 1 |
| 19 | 69854 | Flame Sensor | 1 |
| 20 | 77436 | Burner Blower Assy | 1 |
| 21 | 54724 | Main Combination Gas Valve | 1 |
| 22 | 31651 | Amplifier Board | 1 |
| 23 | 51399 | Cooling Fan | 1 |
| 24 | 77276 | Relay Board | 1 |
| N/S | 76455 | Protective Lens Kit for Photo Sensor (Eye) Assy | 1 |

View of X70G/X55G INSTALLATION KIT

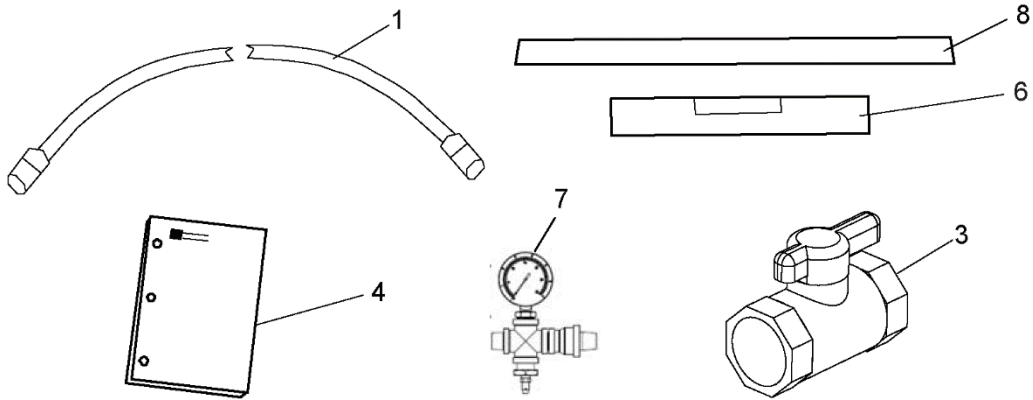

Single Oven Requires One P/N 77594

| ITEM NO. | QTY | PART NO. | DESCRIPTION |
|----------|-----|------------|---|
| 1 | 1 | 22361-0001 | FLEXIBLE GAS HOSE |
| 2 | 1 | 22450-0130 | BAG, POLY 4 MIL 9" X 12" with MINI GRIP |
| 3 | 1 | 23115-0010 | GAS 3/4 BALL "FP" T HANDLE VALVE |
| 4 | 1 | 42612 | SUPPLEMENT SERVICE AGENCY LIST KIT |
| 5 | 1 | 47430 | CARTON 10 X 10 X 36 |
| 6 | 1 | 61823 | BACK SIDE CONV EXT STOP |
| 7 | 1 | 72782 | TAP & ADAPTER ASSY |
| 8 | 1 | 72835 | EXTRUDED 29.25" END STOP |

Double Oven Requires One P/N 78560

| ITEM NO. | QTY | PART NO. | DESCRIPTION |
|----------|-----|------------|---|
| 1 | 2 | 22361-0001 | FLEXIBLE GAS HOSE |
| 2 | 2 | 22450-0130 | BAG, POLY 4 MIL 9" X 12" with MINI GRIP |
| 3 | 2 | 23115-0010 | GAS 3/4 BALL "FP" T HANDLE VALVE |
| 4 | 2 | 42612 | SUPPLEMENT SERVICE AGENCY LIST KIT |
| 5 | 2 | 47430 | CARTON 10 X 10 X 36 |
| 6 | 2 | 61823 | BACK SIDE CONV EXT STOP |
| 7 | 2 | 72782 | TAP & ADAPTER ASSY |
| 8 | 2 | 72835 | EXTRUDED 29.25" END STOP |
| 9 | 1 | 70759 | STACKING GASKET |

Triple Oven Requires One P/N 78561

| ITEM NO. | QTY | PART NO. | DESCRIPTION |
|----------|-----|------------|---|
| 1 | 3 | 22361-0001 | FLEXIBLE GAS HOSE |
| 2 | 3 | 22450-0130 | BAG, POLY 4 MIL 9" X 12" with MINI GRIP |
| 3 | 3 | 23115-0010 | GAS 3/4 BALL "FP" T HANDLE VALVE |
| 4 | 3 | 42612 | SUPPLEMENT SERVICE AGENCY LIST KIT |
| 5 | 3 | 47430 | CARTON 10 X 10 X 36 |
| 6 | 3 | 61823 | BACK SIDE CONV EXT STOP |
| 7 | 3 | 72782 | TAP & ADAPTER ASSY |
| 8 | 3 | 72835 | EXTRUDED 29.25" END STOP |
| 9 | 2 | 70759 | STACKING GASKET |

View of X55GWB INSTALLATION KIT

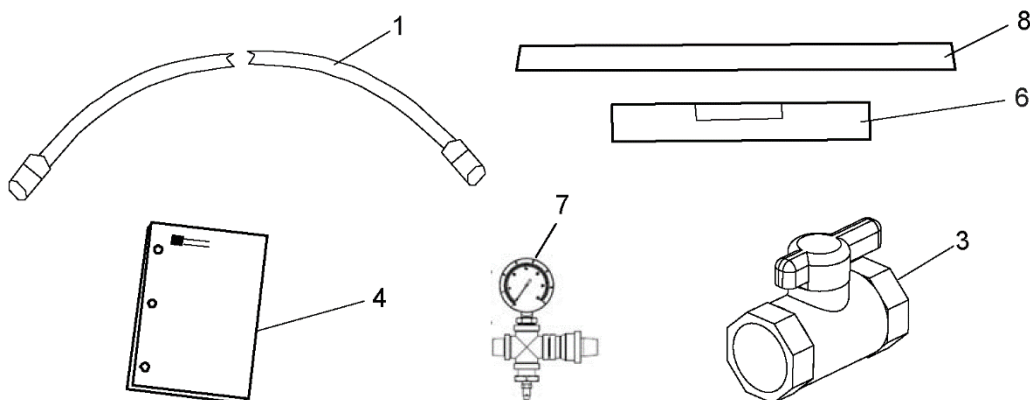

Single Oven Requires One P/N 77594

| ITEM NO. | QTY | PART NO. | DESCRIPTION |
|----------|-----|------------|---|
| 1 | 1 | 22361-0001 | FLEXIBLE GAS HOSE |
| 2 | 1 | 22450-0130 | BAG, POLY 4 MIL 9" X 12" with MINI GRIP |
| 3 | 1 | 23115-0010 | GAS 3/4 BALL "FP" T HANDLE VALVE |
| 4 | 1 | 42612 | SUPPLEMENT SERVICE AGENCY LIST KIT |
| 5 | 1 | 47430 | CARTON 10 X 10 X 36 |
| 6 | 1 | 61823 | BACK SIDE CONV EXT STOP |
| 7 | 1 | 72782 | TAP & ADAPTER ASSY |
| 8 | 1 | 72835 | EXTRUDED 29.25" END STOP |

Double Oven Requires One P/N 78560

| ITEM NO. | QTY | PART NO. | DESCRIPTION |
|----------|-----|------------|---|
| 1 | 2 | 22361-0001 | FLEXIBLE GAS HOSE |
| 2 | 2 | 22450-0130 | BAG, POLY 4 MIL 9" X 12" with MINI GRIP |
| 3 | 2 | 23115-0010 | GAS 3/4 BALL "FP" T HANDLE VALVE |
| 4 | 2 | 42612 | SUPPLEMENT SERVICE AGENCY LIST KIT |
| 5 | 2 | 47430 | CARTON 10 X 10 X 36 |
| 6 | 2 | 61823 | BACK SIDE CONV EXT STOP |
| 7 | 2 | 72782 | TAP & ADAPTER ASSY |
| 8 | 2 | 72835 | EXTRUDED 29.25" END STOP |
| 9 | 1 | 70759 | STACKING GASKET |

Triple Oven Requires One P/N 78561

| ITEM NO. | QTY | PART NO. | DESCRIPTION |
|----------|-----|------------|---|
| 1 | 3 | 22361-0001 | FLEXIBLE GAS HOSE |
| 2 | 3 | 22450-0130 | BAG, POLY 4 MIL 9" X 12" with MINI GRIP |
| 3 | 3 | 23115-0010 | GAS 3/4 BALL "FP" T HANDLE VALVE |
| 4 | 3 | 42612 | SUPPLEMENT SERVICE AGENCY LIST KIT |
| 5 | 3 | 47430 | CARTON 10 X 10 X 36 |
| 6 | 3 | 61823 | BACK SIDE CONV EXT STOP |
| 7 | 3 | 72782 | TAP & ADAPTER ASSY |
| 8 | 3 | 72835 | EXTRUDED 29.25" END STOP |
| 9 | 2 | 70759 | STACKING GASKET |

View of X70G/X55G OVEN BASE/TOP KIT with 19" LEGS

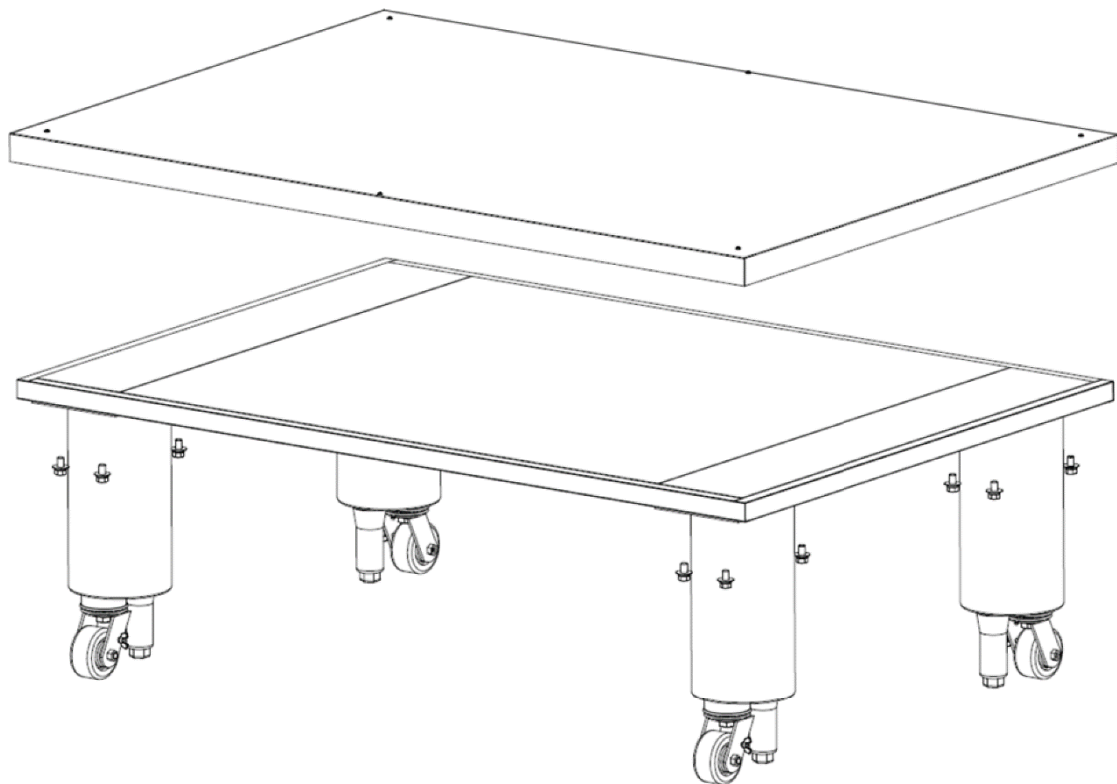

View of X70G/X55G OVEN BASE/TOP KIT with 15" LEGS

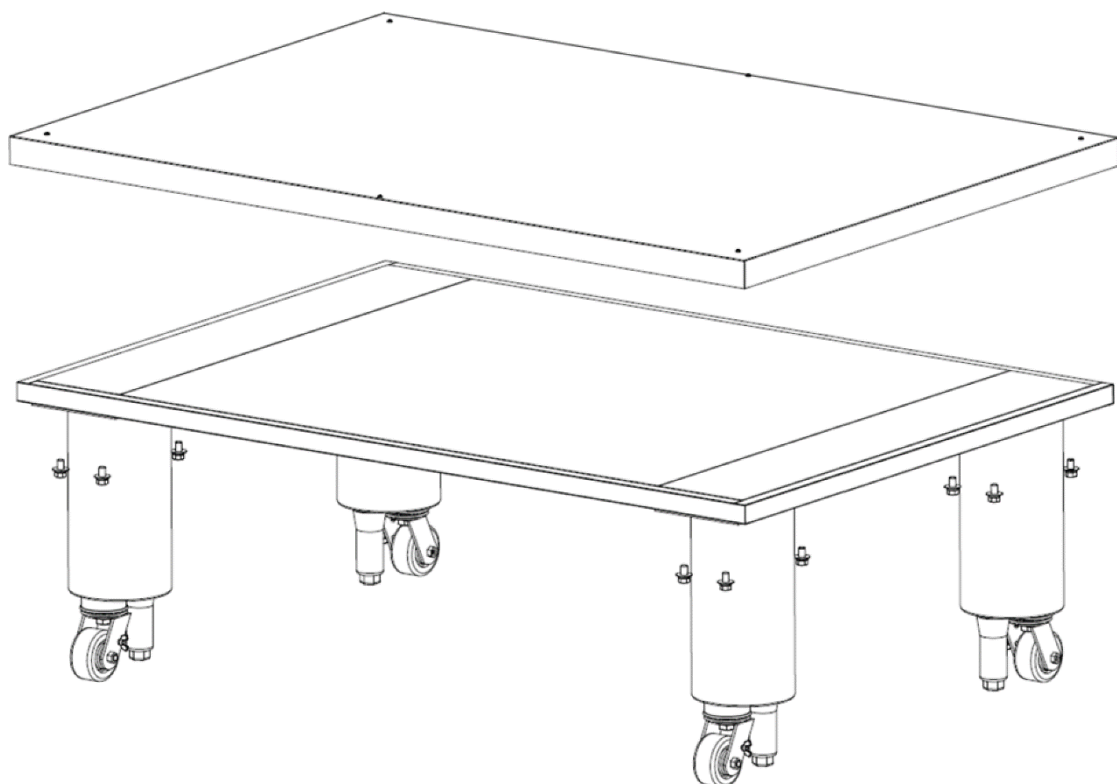

View of X70G/X55G/X55GWB TRIPLE OVEN BASE/TOP KIT

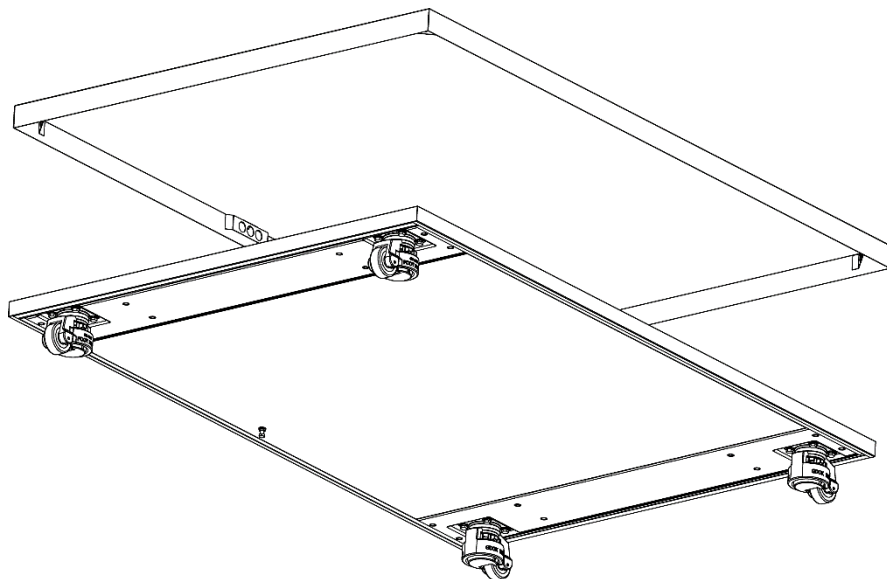

**PARTS LIST FOR SINGLE and DOUBLE X70G OVEN BASE/TOP KIT with 10" LEGS
P/N: 77609**

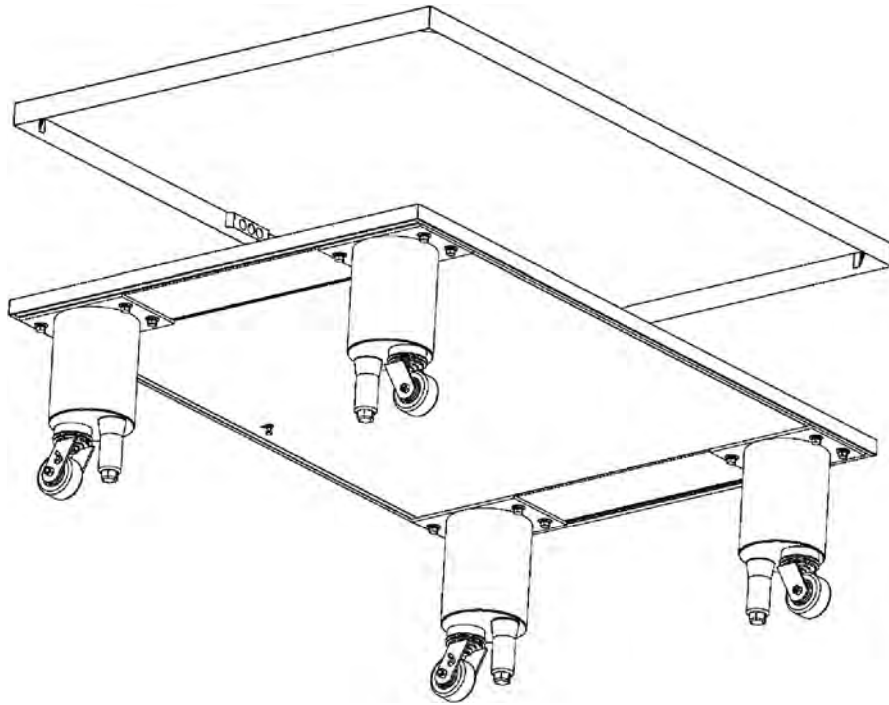

| ITEM NO. | QTY | PART NO. | DESCRIPTION |
|----------|-----|------------|---|
| 1 | 1 | 76772 | BASE ASSEMBLY (X70 Series) |
| 2 | 1 | 77470 | COVER ASSEMBLY/CORNER BRACE |
| 3 | 4 | 70049 | 10" LEG WELDMENT PS360G |
| 4 | 4 | 74319 | CASTER with BRAKE & 4" WHEEL |
| 5 | 4 | 22450-0028 | 6" ADJUSTABLE LEVELING LEG with 3/4" STUD |
| 6 | 16 | 21416-0003 | WASHER, FLAT 1/2 SS |
| 7 | 16 | 2001045 | SCREWS CAP HX HD 1/2-13X1 ZP |
| 8 | 16 | 21426-0004 | WASHER, LOCK 1/2 SS |
| 9 | 1 | 31239 | NUT, HEX FLANGE LOCKING 5/16-18 |
| 10 | 1 | 61832 | SCREW, HEX 5/16-18 1-1/2" |

**PARTS LIST FOR SINGLE and DOUBLE X55G OVEN BASE/TOP KIT with 10" LEGS
P/N: 77613**

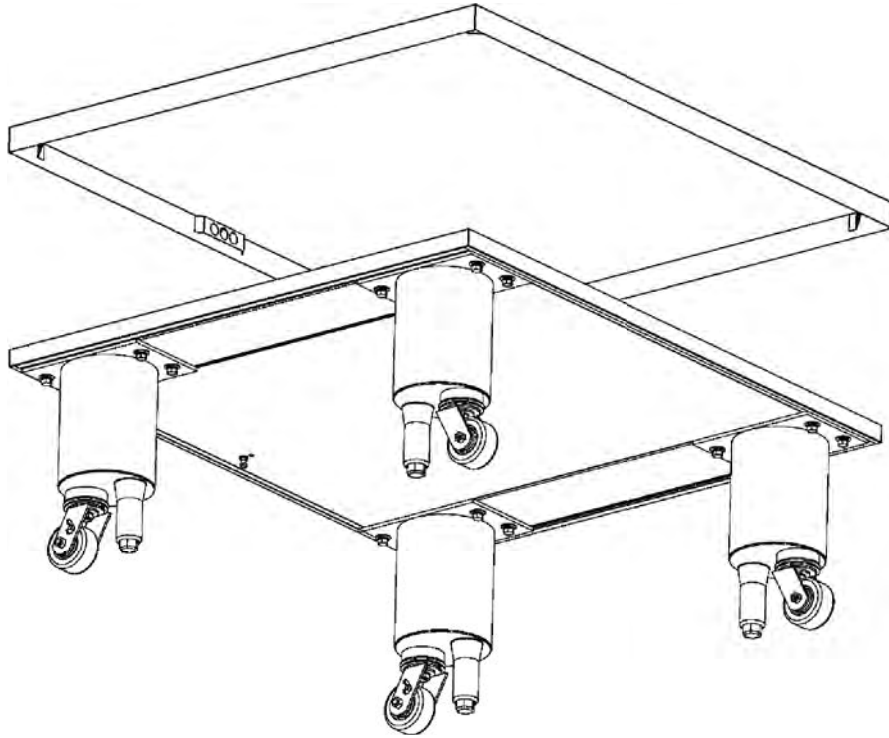

| ITEM NO. | QTY | PART NO. | DESCRIPTION |
|----------|-----|------------|---|
| 1 | 1 | 22450-0228 | RETRAINING DEVICE |
| 2 | 1 | 77088 | BASE ASSEMBLY (X55 Series) |
| 3 | 1 | 77492 | COVER ASSEMBLY TOP/CORNER BRACE |
| 4 | 4 | 70049 | 10" LEG WELDMENT PS360G |
| 5 | 4 | 74319 | CASTER with BRAKE & 4" WHEEL |
| 6 | 4 | 22450-0028 | 6" ADJUSTABLE LEVELING LEG with 3/4" STUD |
| 7 | 16 | 21416-0003 | WASHER, FLAT 1/2 SS |
| 8 | 16 | 2001045 | SCREWS CAP HX HD 1/2-13X1 ZP |
| 9 | 16 | 21426-0004 | WASHER, LOCK 1/2 SS |
| 10 | 1 | 31239 | NUT, HEX FLANGE LOCKING 5/16-18 |
| 11 | 1 | 61832 | SCREW, HEX 5/16-18 1-1/2" |

Parts for X55GWB BASE PAD KIT

| ITEM | QTY. SGL./DBL. OVEN/W 19" LEGS | QTY. DBL. OVEN/W 4" LEGS, CASTERS | QTY. TRIPLE OVEN | P/N | DESCRIPTION |
|-------------------|---|--|------------------------|------------|--|
| 1A | 1 | — | — | 61838 | LEG, 19" (483 mm) |
| 1B | | | | | LEG, 10" (254 mm), No Longer Available |
| 1C | | | | | LEG, 15" (381 mm) |
| 1D | | | | | LEG, 4" (102 mm) (43158, set of 4) |
| 3A | — | — | 4 | 70060 | LEVELING CASTER (1650 LBS) |
| 3B | 4 | 4 | — | 74319 | CASTER STUD with BRAKE & 4" WHEEL |
| 6 | | | | | PIPE CLAMP, 1-1/2" |
| 7 | | | | | NIPPLE, 1-1/4" DIA. X 3" L, NPT |
| 7A | | | | | PIPE, 1-1/4" DIA. X 6" L |
| 8 | | | | | ELBOW, 90°, 1-1/4" DIA. |
| 9 | | | | | GAS HOSE, 1-1/4" DIA. x 72" L |
| 10 | 4 | 4 | — | 22450-0028 | LEG, 6" (152 mm) ADJUSTABLE WITH 3/4" STUD |
| 11 | | | | | GAS PIPE, 1-1/4" DIA. x 54" L |
| 12 | 1 | 1 | 1 | 22450-0228 | RESTRAINING DEVICE |
| 13 | | | | | EYE BOLT, BASE PAD |
| 14 | 1 | 1 | 1 | 77631 | TOP COVER ASSEMBLY/CORNER BRACE |
| 15 | 1 | 1 | 1 | 77233 | BASE PAD |
| NOT SHOWN: | | | | | |
| — | 16 | 16 | — | 2001045 | SCREW, CAP HEX HEAD 1/2-13 x 1 ZP |
| — | 1 | 1 | 1 | 61832 | SCREW, HEX 5/16-18 1-1/2" |
| — | 1 | 1 | 1 | 31239 | NUT, HEX FLANGE LOCKING 5/16-18 |
| — | 16 | 16 | — | 21416-0003 | FLAT WASHER, 1/2" |
| — | 16 | 16 | — | 21426-0004 | LOCK WASHER, 1/2" SS |
| — | — | — | 16 | A27721 | WASHER, LOCK 3/8 |
| — | — | — | 16 | 220373 | SCREWS CAP HX HD 3/8-16X1 18-8 |
| — | — | — | 16 | 21416-0001 | WASHER, FLAT 3/8 18-8 |

View of BLOWER WHEELS

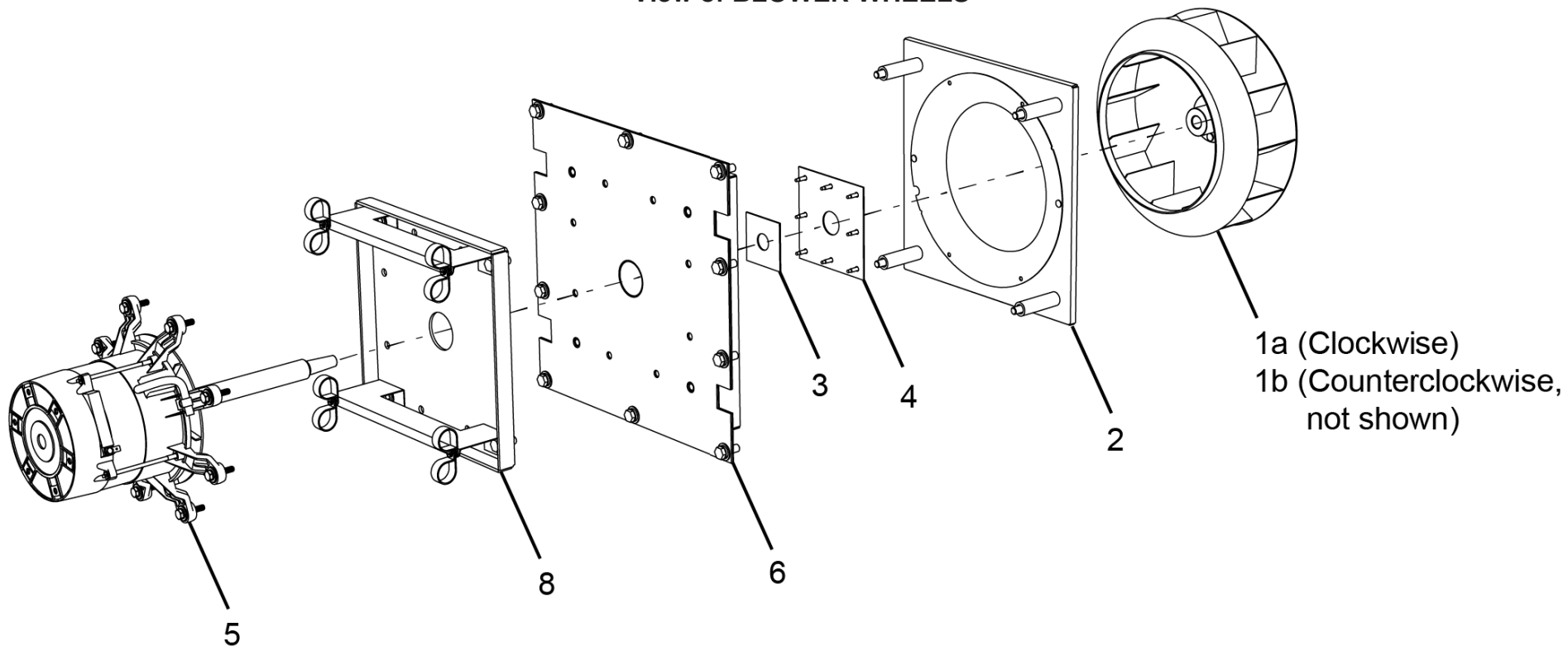

Parts for BLOWER WHEELS

| ITEM | QTY. | P/N | DESCRIPTION |
|------|------|-------|---|
| 1a | 1 | 76888 | WHEEL, IDLER SIDE, BLWR 12-1/4 12 BLD CW |
| 1b | 1 | 76887 | WHEEL, DRIVE SIDE, BLWR 12-1/4 12 BLD CCW |
| 2 | 1 | 76559 | WLDMNT, PLATE ORIFICE RING |
| 3 | 1 | 76858 | SHAFT, INNER SEAL |
| 4 | 1 | 77032 | WLDMT, INNER SHAFT SEAL X70 |
| 5 | 1 | 76118 | MTR, HAVENTIC L9, 230V, 3PH, 60HZ |
| 6 | 1 | 76549 | WLDMT, BACK WALL D-DRIVE |
| 8 | 1 | 65107 | PLATE, MTR REINF, D-DRIVE |

View(s) of BURNER/BLOWER ASSEMBLY

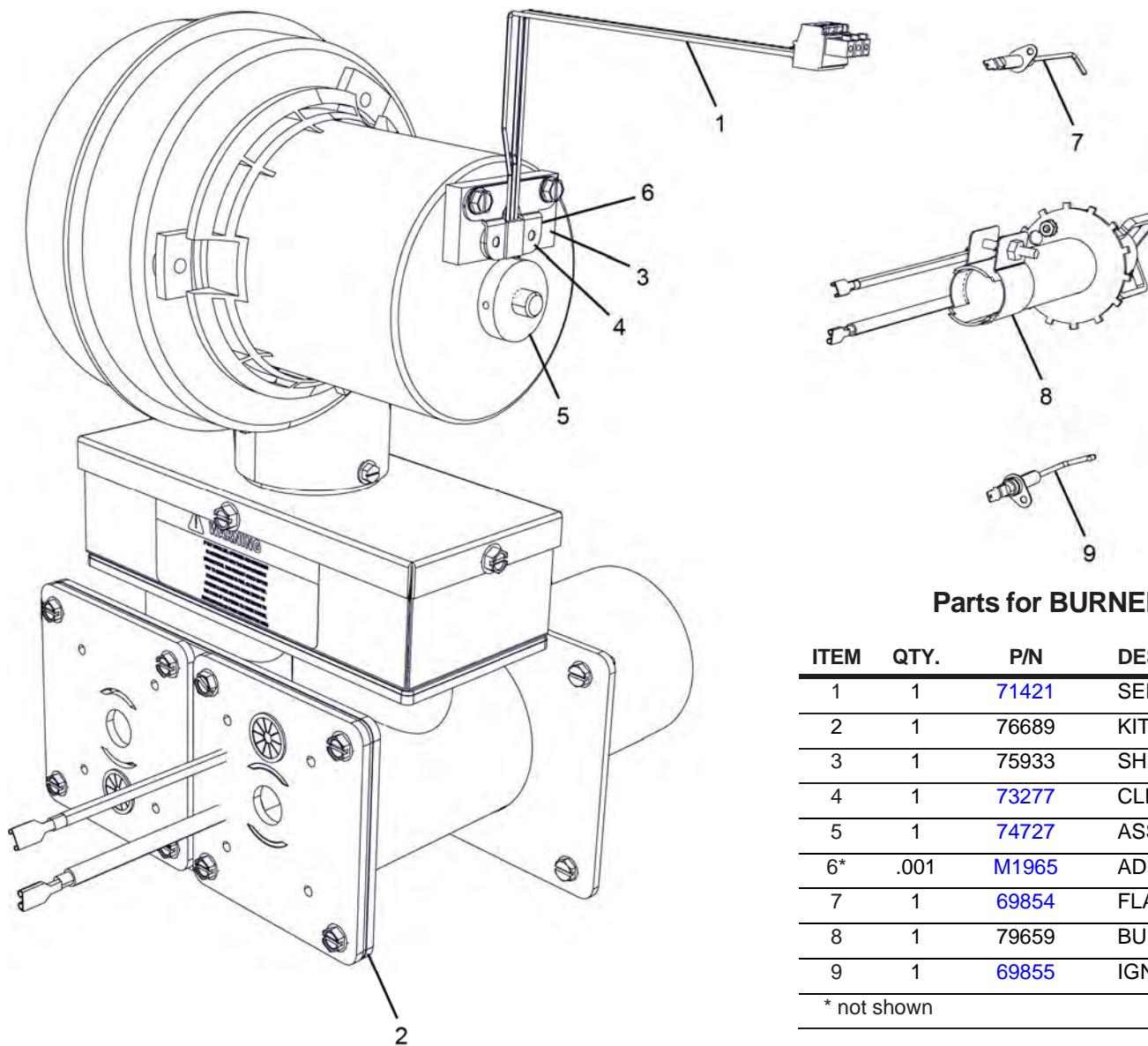

Parts for BURNER/BLOWER ASSEMBLY

| ITEM | QTY. | P/N | DESCRIPTION |
|------|------|-------|-------------------------------|
| 1 | 1 | 71421 | SENSOR, HAMLIN 55100 HALL EFF |
| 2 | 1 | 76689 | KIT, BLWR MTR/SGL BURNR |
| 3 | 1 | 75933 | SHIM, BLWR SENSOR HAMLIN |
| 4 | 1 | 73277 | CLIP, SENSOR |
| 5 | 1 | 74727 | ASSY, MAGNET RING .314 BORE |
| 6* | .001 | M1965 | ADHESIVE, SILICONE RTV |
| 7 | 1 | 69854 | FLAME SENSOR ELECTRODE, SC80 |
| 8 | 1 | 79659 | BURNERS X SERIES SERVICE KIT |
| 9 | 1 | 69855 | IGNITOR, SINGLE ROD |

* not shown

View of CONTROL BOX LR OT ASSEMBLY

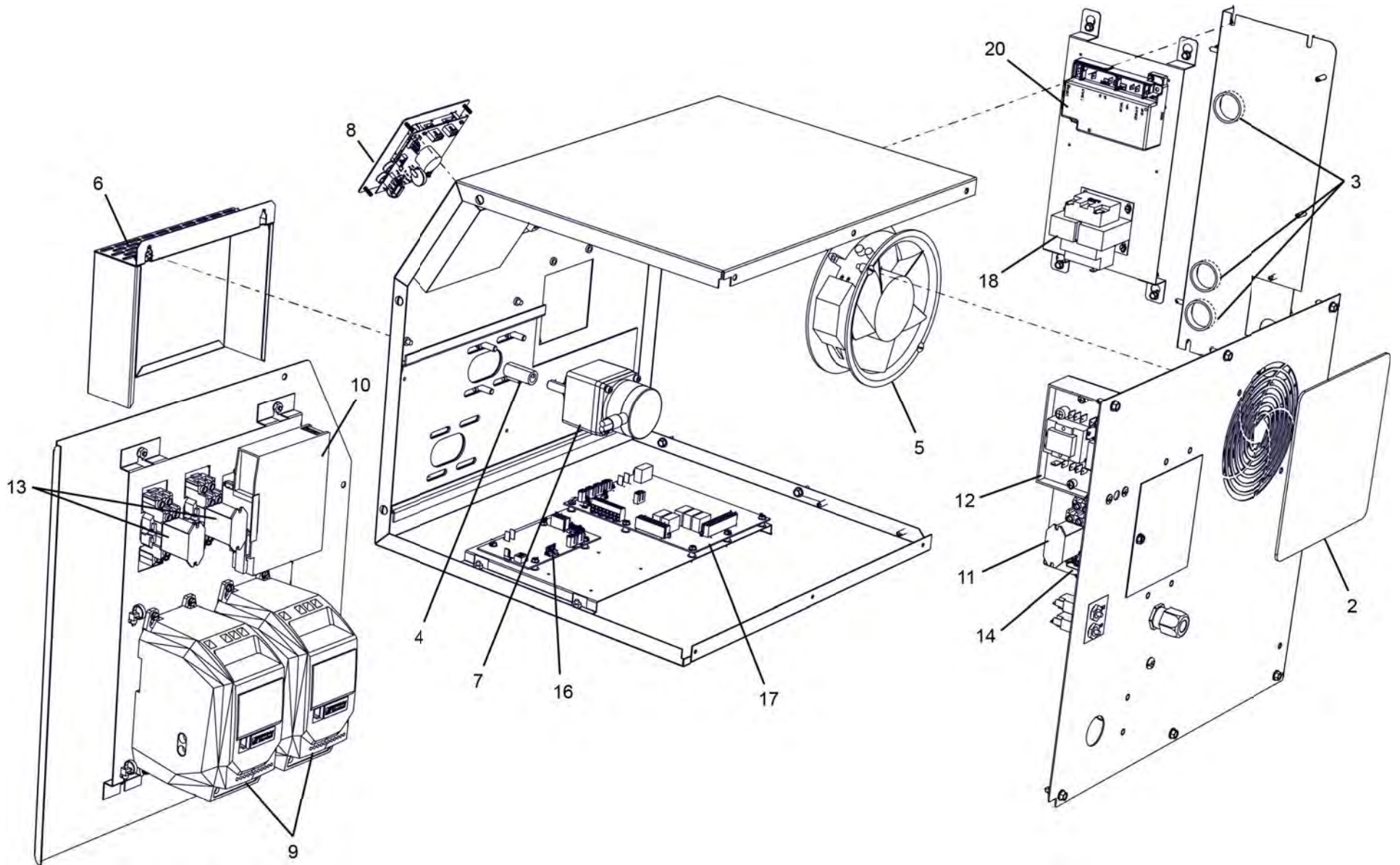

Parts for CONTROL BOX LR OT ASSEMBLY

| ITEM | QTY. | P/N | DESCRIPTION |
|------------|------|-------|--|
| 1 | 1 | 77764 | BEZEL, MLUI |
| 2 | 1 | 77553 | FILTER, MAGNETIC 180 MM FAN |
| 3 | 3 | M0709 | BUSHING, PASS THRU 1-1/2" |
| 4 | 1 | 65818 | ADAPTER, MOTOR SHAFT |
| 5 | 1 | 51399 | FAN, COOLING 230V AC 295 CFM |
| 6 | 1 | 70295 | BOX, CHAIN CRV |
| 7 | 1 | 74106 | MOTOR, GEAR 1:200 25W |
| 8 | 1 | 79324 | CONTROLLER |
| 9 | 2 | 74097 | PROGRAMMED, INVERTEK X SERIES |
| 10 | 1 | 76979 | SUPPLY, POWER 24 VDC / 60 W |
| 11 | 1 | 60952 | RELAY, DPDT 240VAC COIL, 10 A |
| 12 | 1 | 33983 | CNTRL, ELECT HI-LIMIT 240V |
| 13 | 2 | 71771 | RELAY, DPDT, 24VDC COIL |
| 14 | N/A | 77020 | SOCKET, DIN RAIL RELAY IDEC (REF ONLY – INCLUDED IN HARNESS) |
| 15* | 1 | 77276 | BOARD, RELAY |
| 16 | 1 | 77277 | BOARD, DRIVE |
| 17 | 1 | 77275 | BOARD, I/O |
| 18 | 2 | 32108 | XFMR, 240V PRO 24V 65VA SEC |
| 19* | 1 | 31651 | AMPLIFIER, SIGNAL 4-20VDC |
| 20 | 1 | 78218 | MODULE, DUAL IGNITION (BAS) |
| *not shown | | | |

View of PHOTOEYE/BOX ASSEMBLY

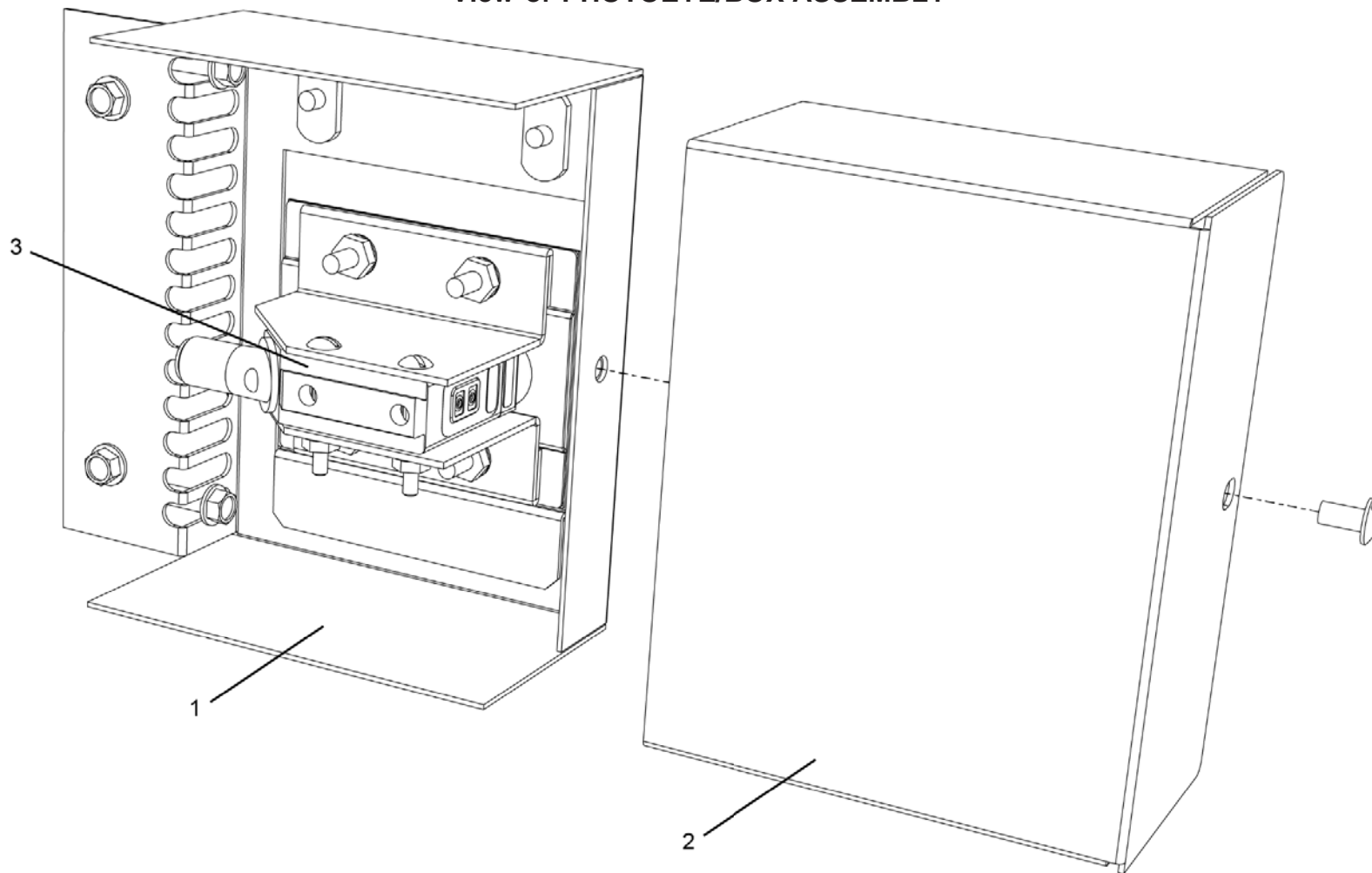

Parts for PHOTOEYE/BOX ASSEMBLY

| ITEM | QTY. | P/N | DESCRIPTION |
|------|------|-----------------------|---------------------------------|
| 1 | 1 | 76540 | WLDMT, PHOTOEYE BOX |
| 2 | 1 | 76525 | PANEL, LH REAR PHOTOEYE |
| 3 | 1 | 72209 | SENSOR/PHOTOEYE REPLACEMENT KIT |

View of MANIFOLD/PIPE ASSEMBLY

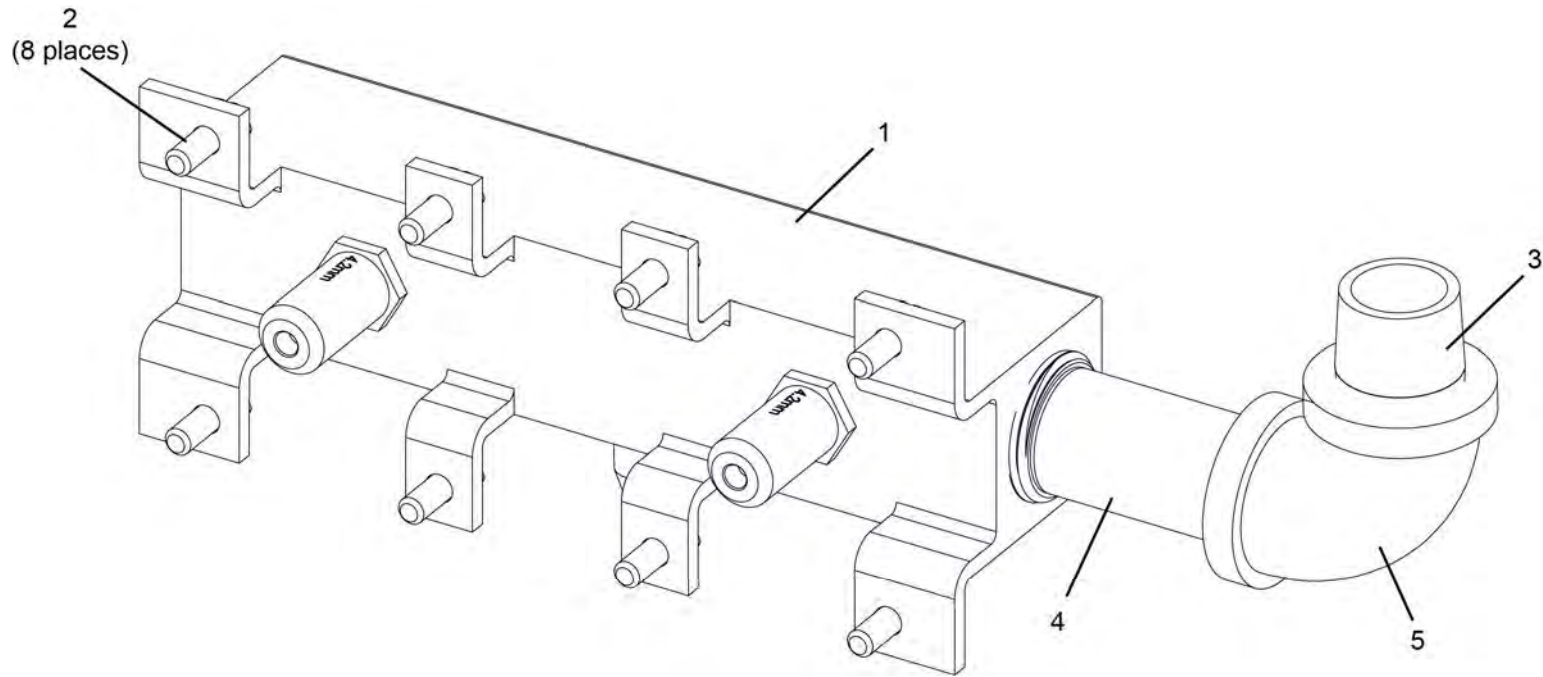

Parts for MANIFOLD/PIPE ASSEMBLY

| ITEM | QTY. | P/N | DESCRIPTION |
|------|------|------------|---------------------------------|
| 1 | 1 | 76818 | ASSY, MANIFOLD X70 |
| 2 | 8 | 58844 | SCR, MS SL HX W/HD 10-32x1/2 SS |
| 3 | 1 | 23153-0004 | NIPPLE, CLOSE BLK 1/2 |
| 4 | 1 | 23151-0031 | NIPPLE, BLK 1/2 x 2 1/2 |
| 5 | 1 | 23122-0004 | ELBOW, 90 PIPE (150xM1) 0.500 |

View of GAS PIPE ASSEMBLY

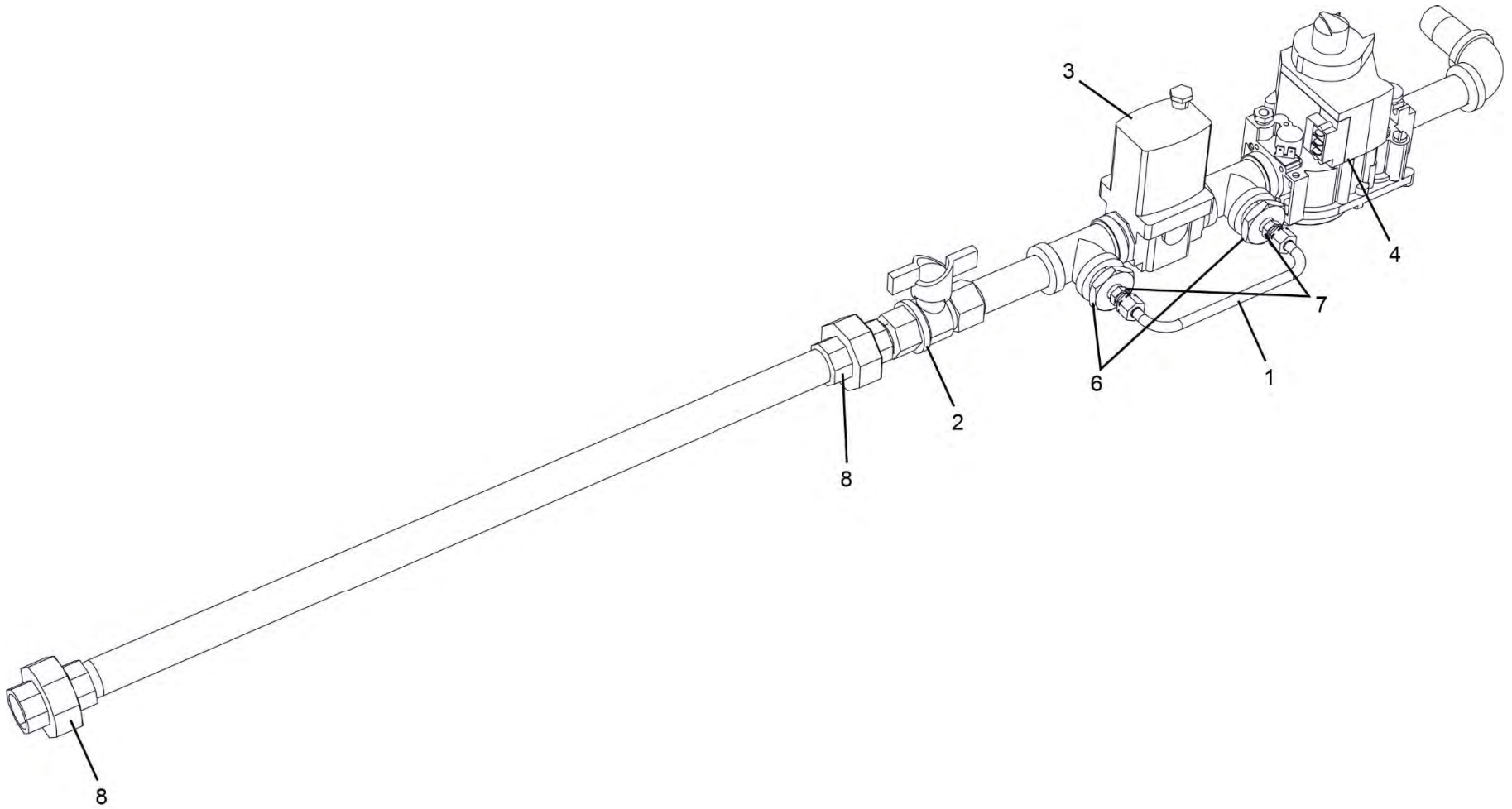

Parts for GAS PIPE ASSEMBLY

| ITEM | QTY. | P/N | DESCRIPTION |
|------|------|------------|----------------------------------|
| 1 | 1 | 70420 | TUBE, 1/4 ALUM BYPASS |
| 2 | 1 | 62307 | VALVE, GAS MANUAL BALL 1/2X1/2 |
| 3 | 1 | 59450 | VALVE, MODULE M420 NO SPRING |
| 4 | 1 | 54724 | VALVE, HONEYWELL VR8305M |
| 5 | 1 | 49951 | ORIFICE, BY-PASS #46 W .081 |
| 6 | 2 | 48742 | BUSHING, 1/2-1/8 NPT REDUCE |
| 7 | 2 | 44888 | FITTING, COMP 1/4 TUBE MALE CONN |
| 8 | 2 | 23051-0003 | UNION, PIPE (150#MI) 0.500 |

View of X70 SINGLE BELT CONVEYOR

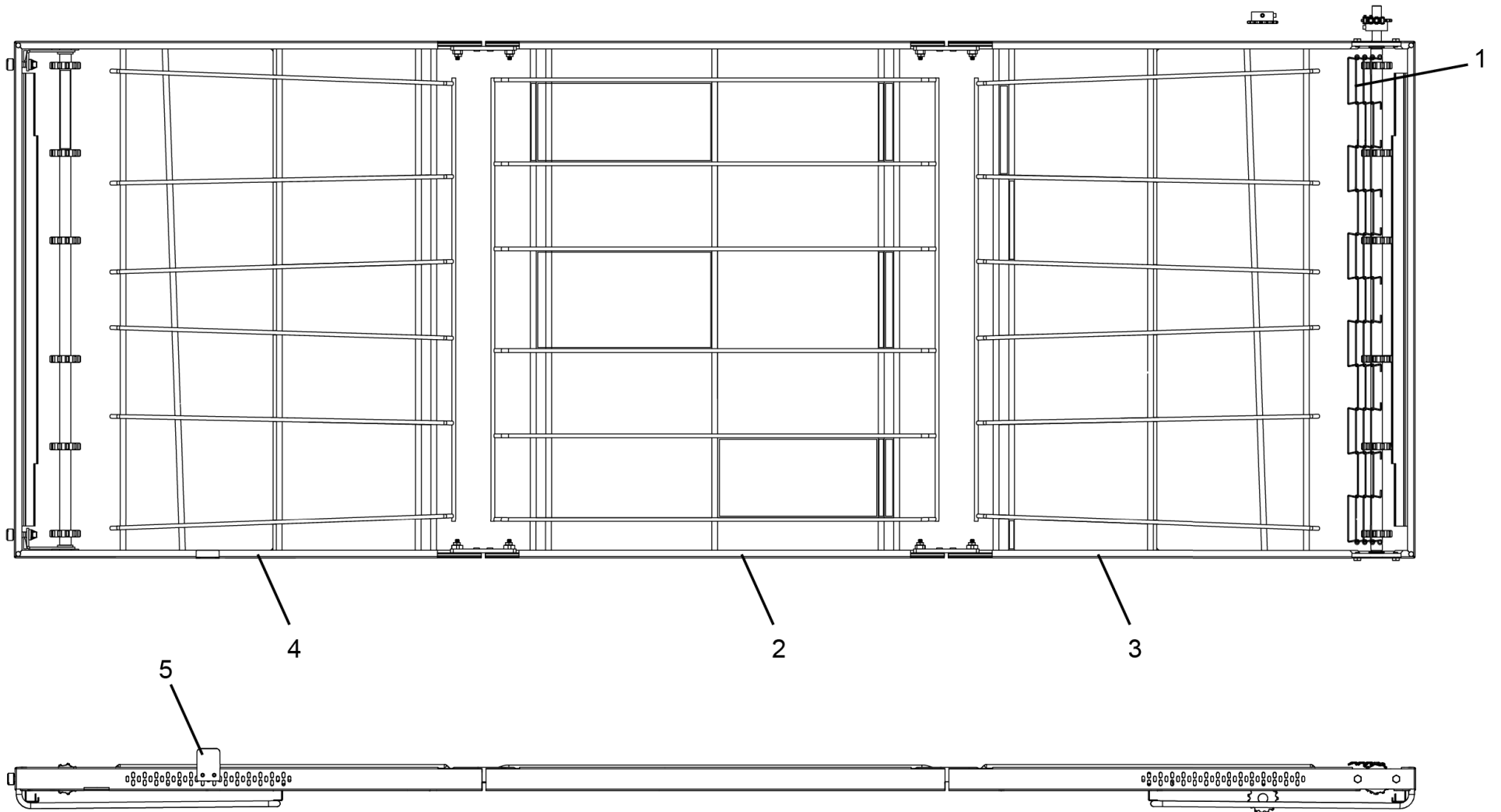

Parts for X70 SINGLE BELT CONVEYOR

| ITEM | QTY. | P/N | DESCRIPTION |
|------|------|-----------------------|---------------------------------|
| 1 | 1 | 74305 | BELT, CONV WIRE SS1/2P 31.5X206 |
| 2 | 1 | 74010 | WLDMT, CONV CTR FRAME |
| 3 | 1 | 77265 | ASSY, CONV DRIVE END SIB |
| 4 | 1 | 76303 | ASSY, CONV IDLER END SIB |
| 5 | 1 | 73299 | ASSY, LASER TARGET |
| | 1 | 79560 | KIT, CONV LINK X70 SIB |

View of X70 SINGLE BELT CONVEYOR IDLER AND DRIVE END ASSEMBLIES

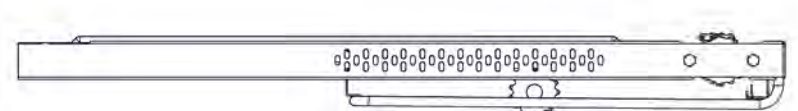
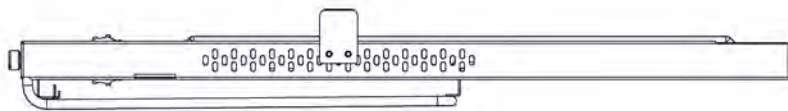
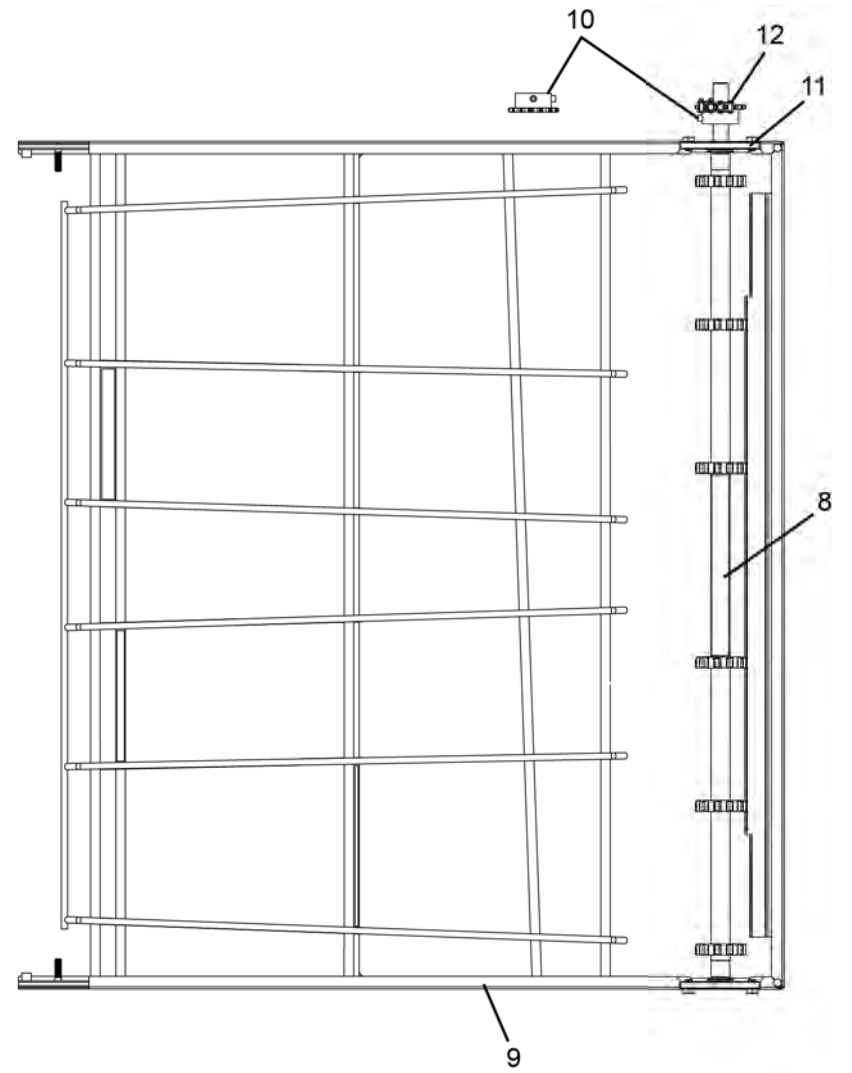
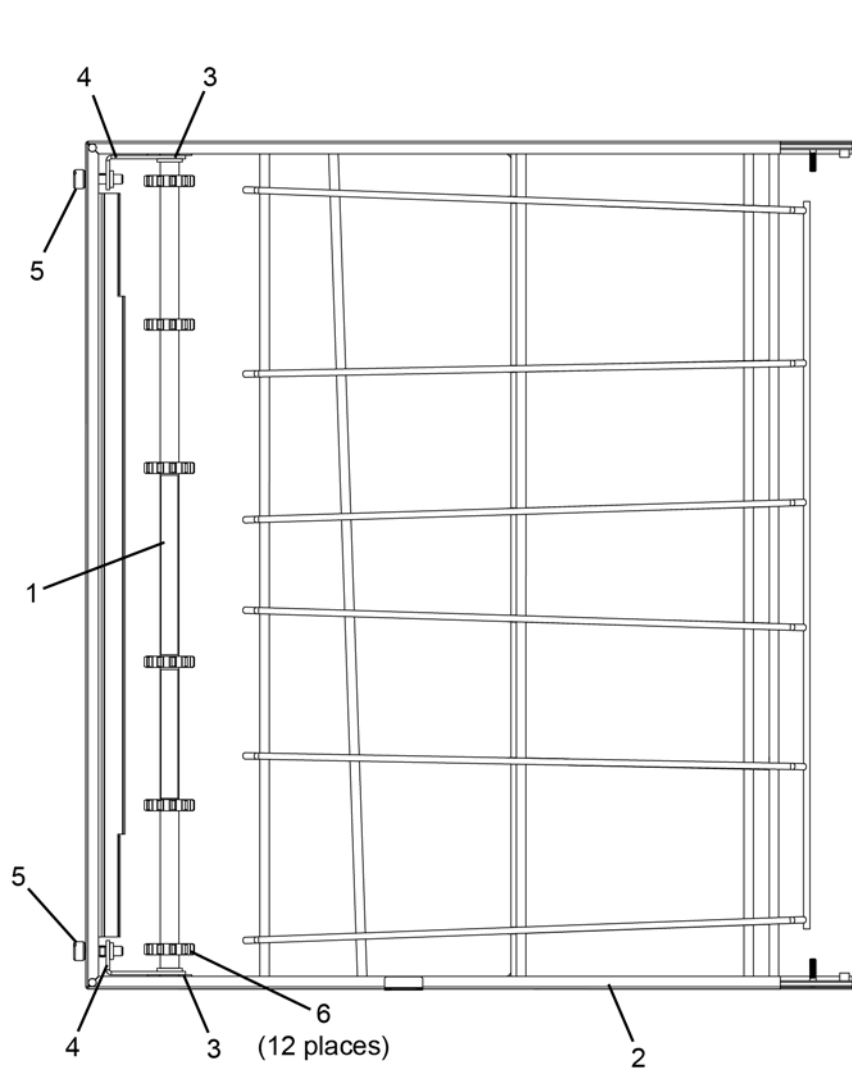

Parts for X70 SINGLE BELT CONVEYOR IDLER AND DRIVE END ASSEMBLIES

| ITEM | QTY. | P/N | DESCRIPTION |
|-------------|------|----------------------------|--------------------------------|
| 1 | 1 | 35000-1011 | SHAFT, IDLER-CONV |
| 2 | 1 | 76304 | WLDMT, CONV IDLER FRAME |
| 3 | 2 | 60179 | BRKT, SLIDER CONV |
| 4 | 2 | 37000-0413 | WLDMT, IDLER BRACKET |
| 5 | 2 | 35000-1008 | SCR, ADJ-CONV IDLER |
| 6 | 12 | 22229-0003 | SPRKT, CONV DRIVE 2.0D W/SCR |
| 7* | 2 | 22034-0003 | BUSH, FLANGE 3/4OD X 5/8ID N/D |
| 8 | 1 | 77266 | SHAFT, DRIVE CONV |
| 9 | 1 | 76307 | WLDMT, CONV DRIVE FRAME |
| 10 | 2 | 66581 | SPRKT, #35-15T-5/8 BORE |
| 11 | 2 | 69734 | ASSY, BEARING BLOCK |
| 12 | 1 | 70492 | ASSY, CHAIN ROLLER 21" |
| * not shown | | | |

View of X70 SPLIT BELT CONVEYOR

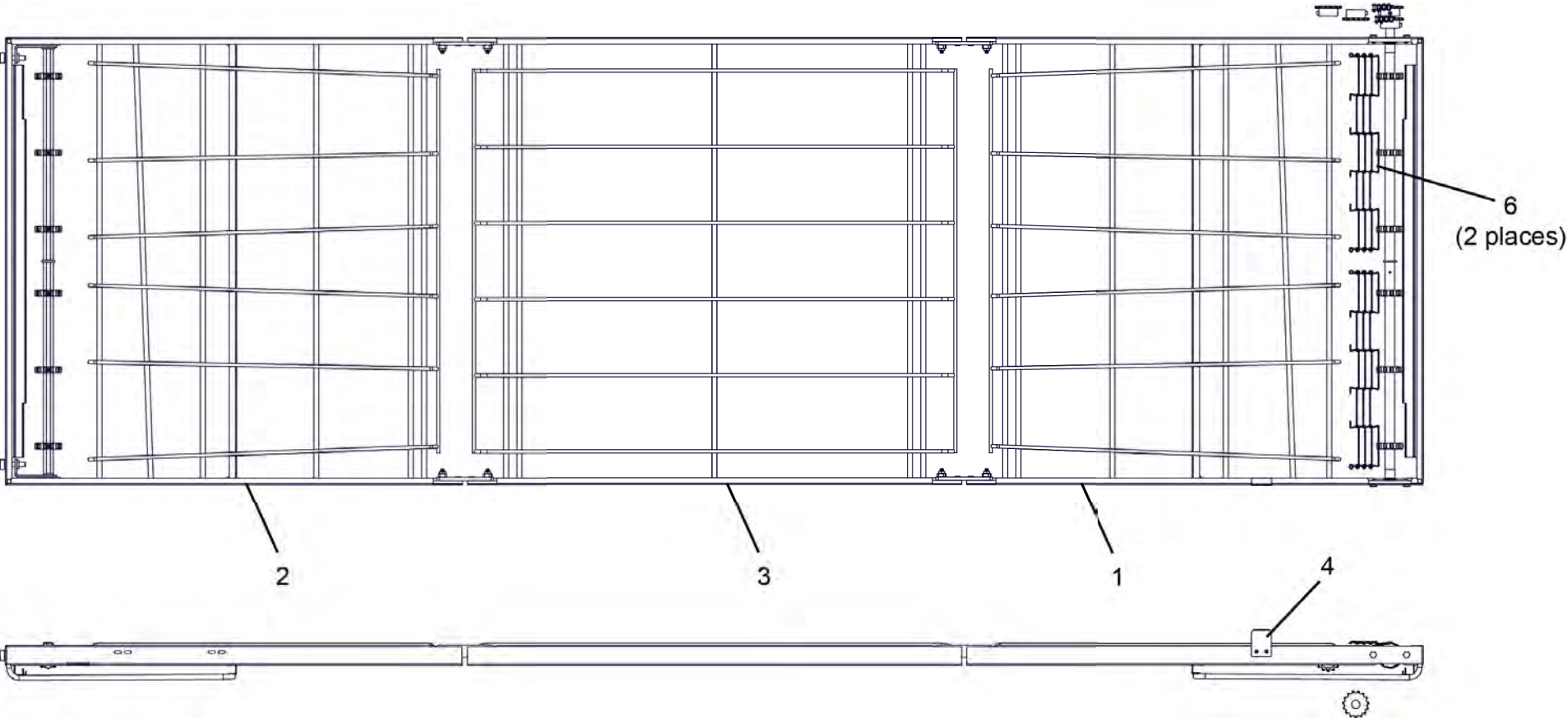

Parts for X70 SPLIT BELT CONVEYOR

| ITEM | QTY. | P/N | DESCRIPTION |
|-------------|------|------------|-----------------------------|
| 1 | 1 | 78607 | ASSY, CONV DRIVE END SPB |
| 2 | 1 | 76314 | ASSY, CONV IDLER END SPB |
| 3 | 1 | 74010 | WLDMT, X70 CONV CTR FRAME |
| 4 | 1 | 73299 | ASSY, LASER TARGET |
| 5* | 1 | 65818 | ADAPTER, MOTOR SHAFT |
| 6 | 2 | 22450-0271 | BELT, CONV WIRE SS 1/2PS024 |
| | 2 | 79563 | KIT, CONV LINK X70SPB |
| * not shown | | | |

View of X70 SPLIT BELT CONVEYOR IDLER AND DRIVE END ASSEMBLIES

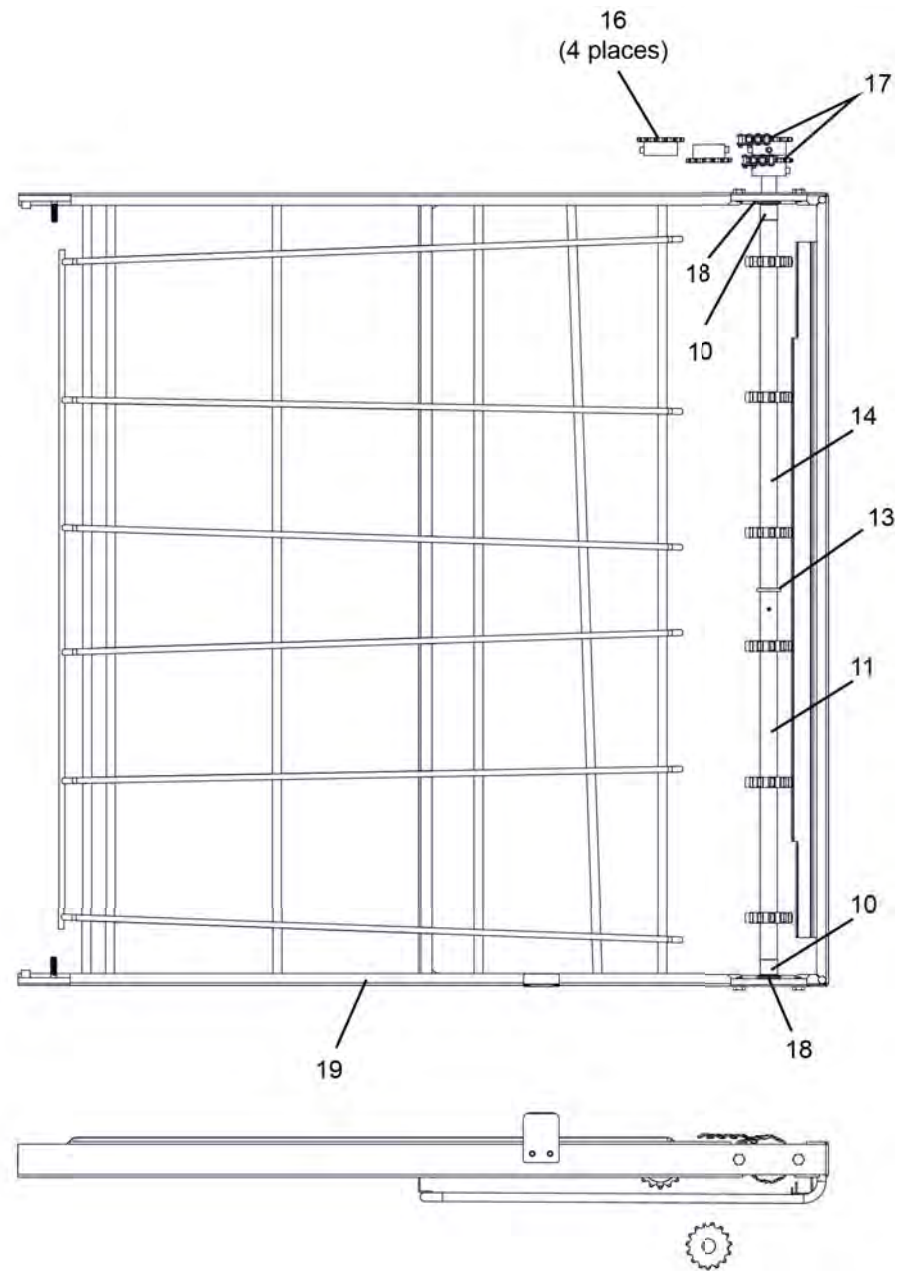
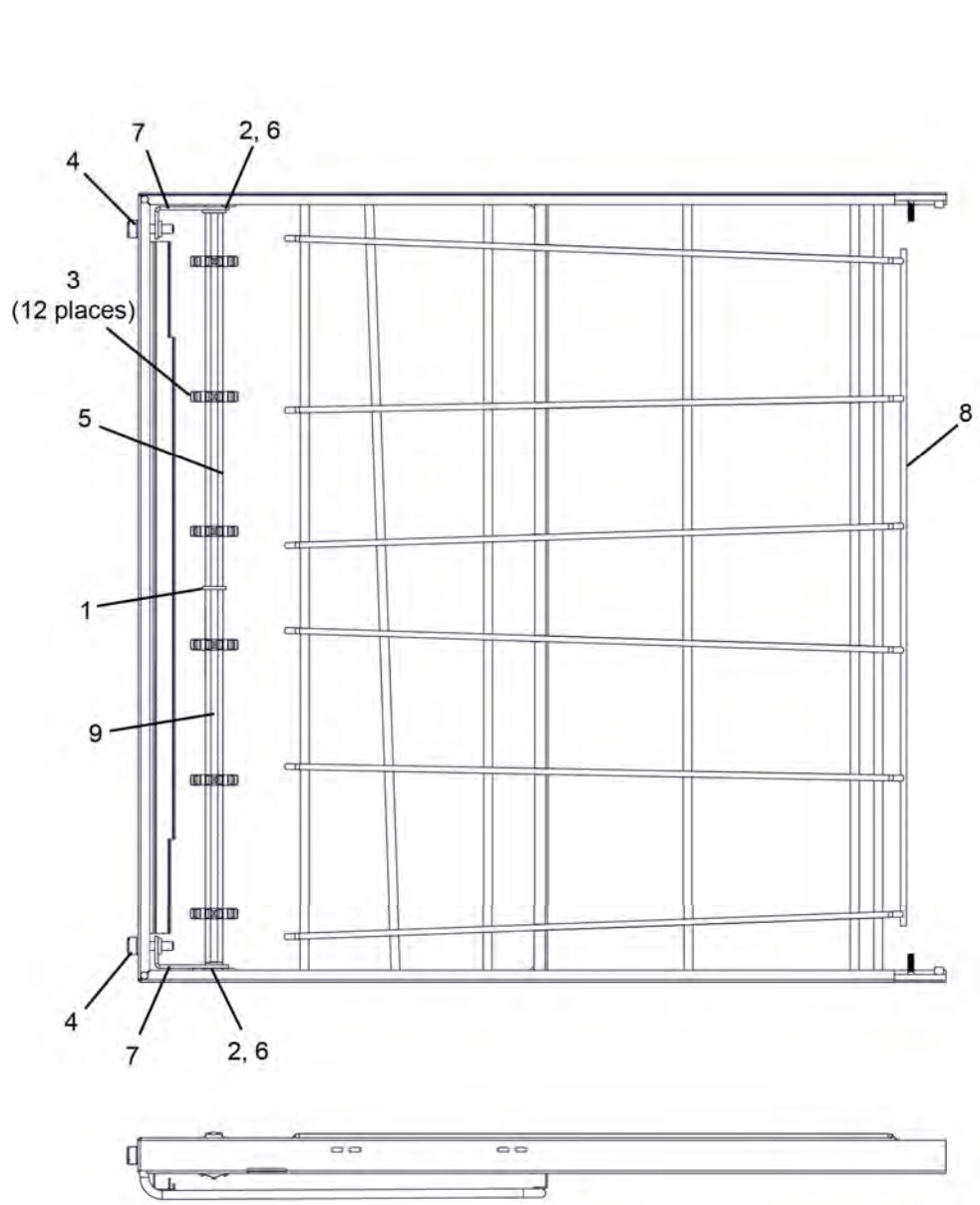

Parts for X70 SPLIT BELT CONVEYOR IDLER AND DRIVE END ASSEMBLIES

| ITEM | QTY. | P/N | DESCRIPTION |
|-------------|------|----------------------------|--------------------------------|
| 1 | 1 | 21415-0001 | WASHER, FLAT BRZ 1"X1/2"X1/8" |
| 2 | 2 | 22034-0003 | BUSH, FLANGE 3/4OD X 5/8ID N/D |
| 3 | 12 | 22229-0003 | SPRKT, CONV DRIVE 2.0D W/SCR |
| 4 | 2 | 35000-1008 | SCR, ADJ-CONV IDLER |
| 5 | 1 | 35000-1535 | WLDMT, IDLER |
| 6 | 2 | 54947 | BRKT, CONVEYOR SHAFT SUPPORT |
| 7 | 2 | 37000-0413 | WLDMT, IDLER BRACKET |
| 8 | 1 | 76304 | WLDMT, CONV IDLER FRAME |
| 9 | 1 | 42400-0354 | ASSY, FRNT CONV IDR SHT |
| 10 | 2 | 74380 | SPACER, .74OD .64ID .65H |
| 11 | 1 | 72220 | ASSY, FRNT CONV DRV SFT |
| 12* | 1 | 72858 | BUSH, SPROCKET – FRONT DRIVE |
| 13 | 1 | 21415-0001 | WASHER, FLAT BRZ 1"X1/2"X1/8" |
| 14 | 1 | 72219 | SHAFT, REAR CONV DRIVE |
| 15* | 1 | 35000-1531 | SPACER, NYLON |
| 16 | 4 | 66581 | SPRKT, #35-15T-5/8 BORE |
| 17 | 2 | 70492 | ASSY, CHAIN ROLLER 21" |
| 18 | 2 | 69734 | ASSY, BEARING BLOCK |
| 19 | 1 | 79167 | WLDMT, CONV DRIVE FRAME |
| * not shown | | | |

View of X55 SINGLE BELT CONVEYOR

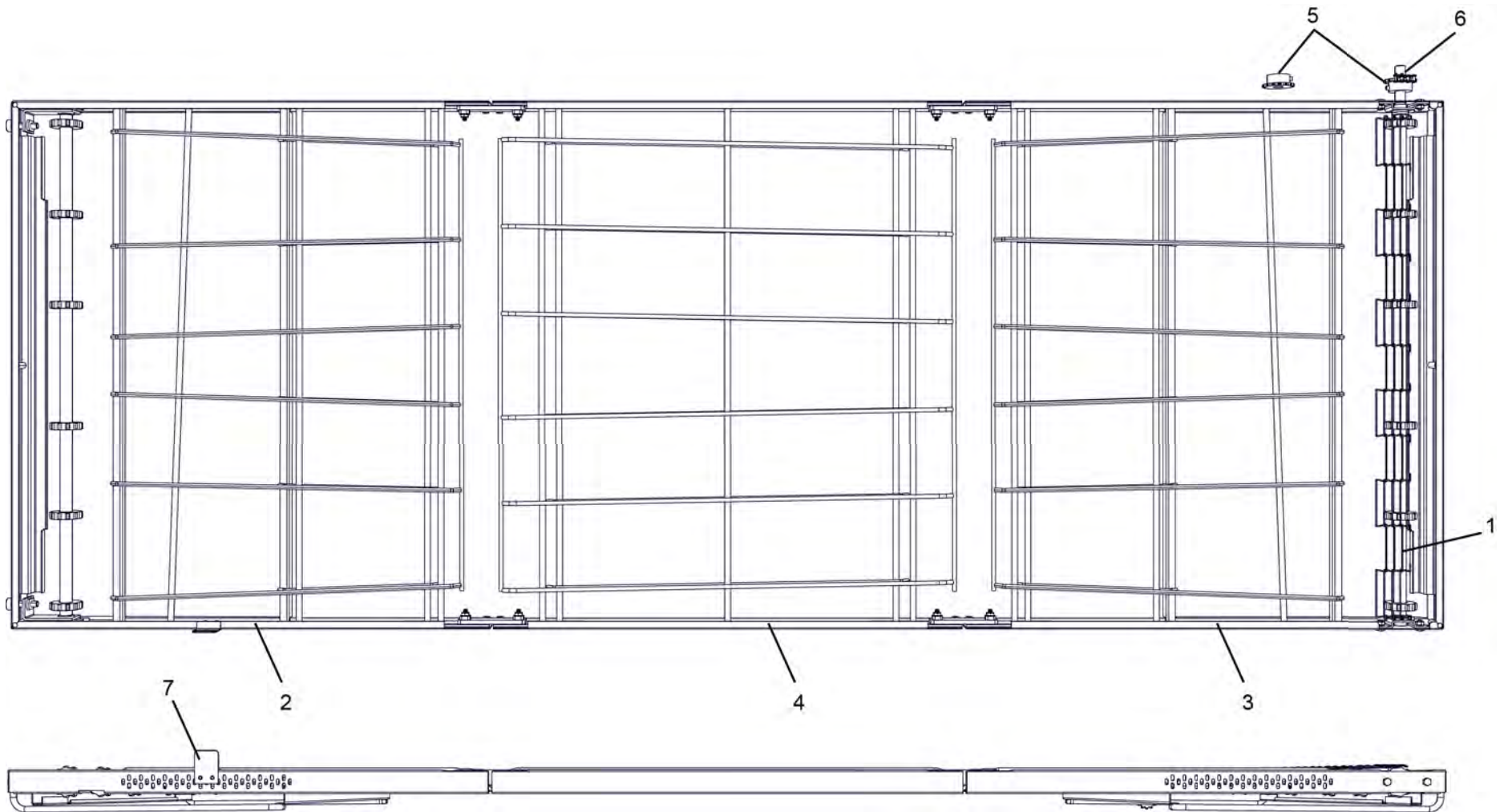

Parts for X55 SINGLE BELT CONVEYOR

| ITEM | QTY. | P/N | DESCRIPTION |
|------|------|----------------------------|----------------------------|
| 1 | 1 | 22450-0001 | BELT, CONV WIRE SS32 |
| 2 | 1 | 69624 | ASSY, CONV FRM/COMPT IDLE |
| 3 | 1 | 69623 | ASSY, CONV FRM/COMPT DRIVE |
| 4 | 1 | 69105 | WLDMT, CONV CTR FRAME |
| 5 | 2 | 66581 | SPRKT, #35-15T-5/8 BORE |
| 6 | 1 | 60123 | ASSY, CHAIN ROLLER 19-5/8" |
| 7 | 1 | 73299 | ASSY, LASER TARGET |
| | 1 | 79564 | KIT, CONV LINK X55 SIB |

View of X55 SINGLE BELT CONVEYOR IDLER AND DRIVE END ASSEMBLIES

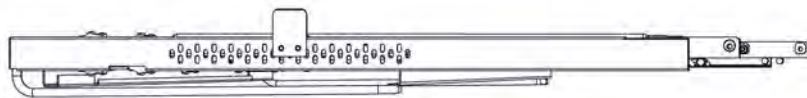
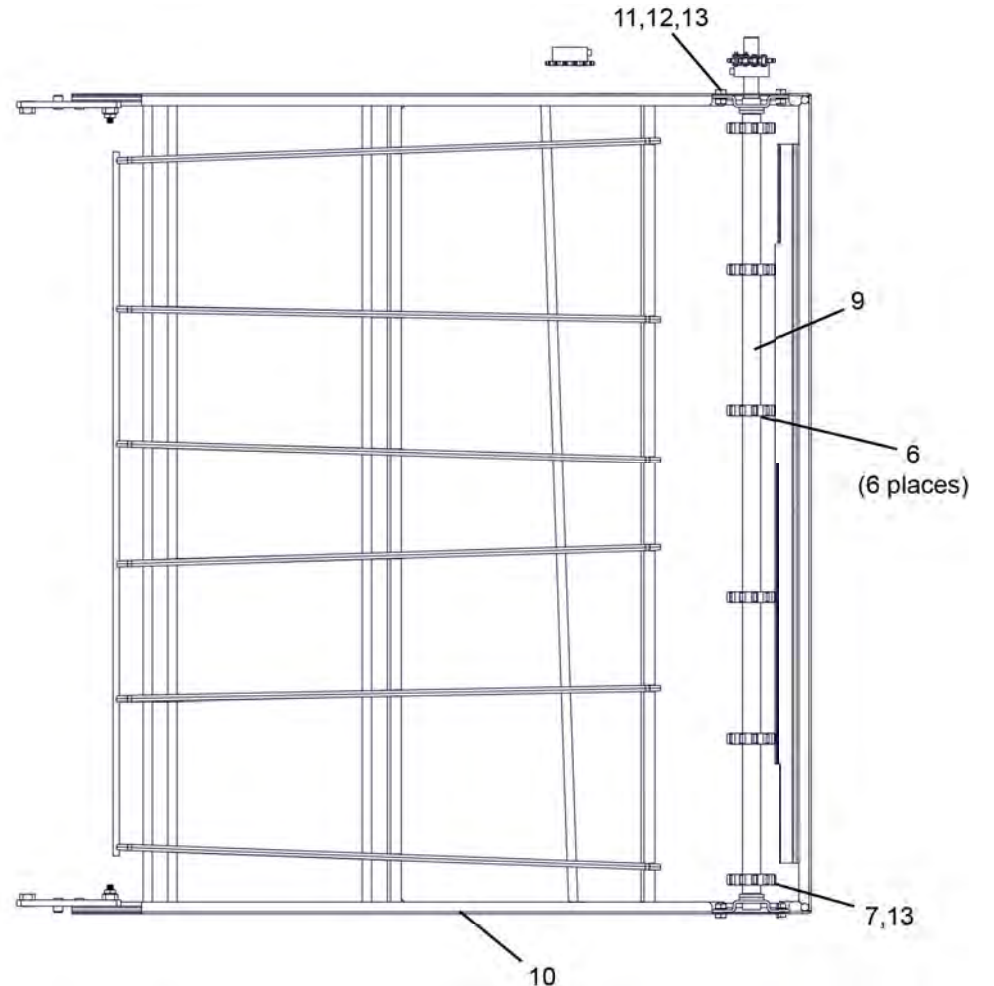
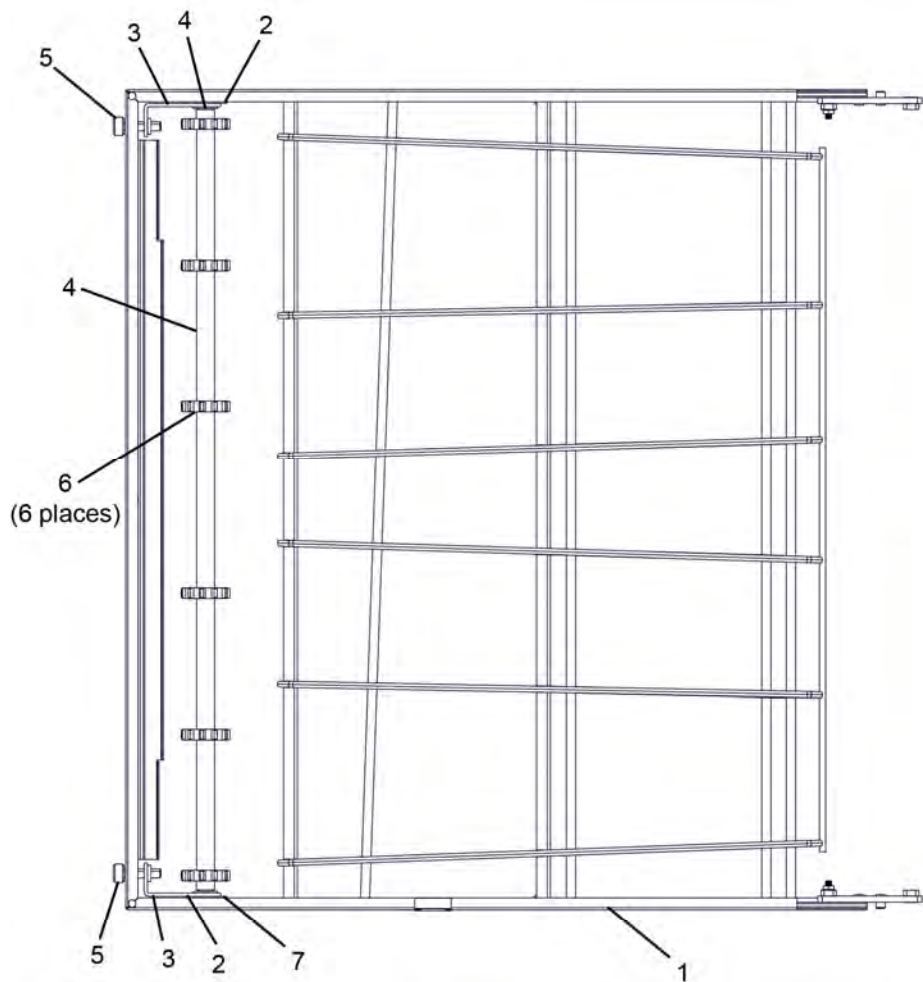

Parts for X55 SINGLE BELT CONVEYOR IDLER AND DRIVE END ASSEMBLIES

| ITEM | QTY. | P/N | DESCRIPTION |
|-------------|-------|------------|--------------------------------|
| 1 | 1 | 73977 | WLDMT, CONV FRM COMP IDL |
| 2 | 2 | 60179 | BRK, SLIDER CONV |
| 3 | 2 | 37000-0413 | WLDMT, IDLER BRACKET |
| 4 | 1 | 35000-1011 | SHAFT, IDLER-CONV |
| 5 | 2 | 35000-1008 | SCR, ADJ-CONV IDLER |
| 6 | 12 | 22229-0003 | SPRKT, CONV DRIVE 2.0D W/SCR |
| 7 | 4 | 22034-0003 | BUSH, FLANGE 3/4OD X 5/8ID N/D |
| 8* | 0.001 | M1965 | ADHESIVE, SILICONE RTV |
| 9 | 1 | 69260 | SHAFT, DRIVE CONV |
| 10 | 1 | 73976 | WLDMT, CONV FRM COMP DRV |
| 11 | 2 | 65173 | WSHR, FLT NYL .631 X 1.00X.128 |
| 12 | 2 | 49972 | BRKT, CONVEYOR SUPPORT |
| 13 | .001 | 2700058 | GASKET, BULK |
| * not shown | | | |

View of X55G SPLIT BELT CONVEYOR

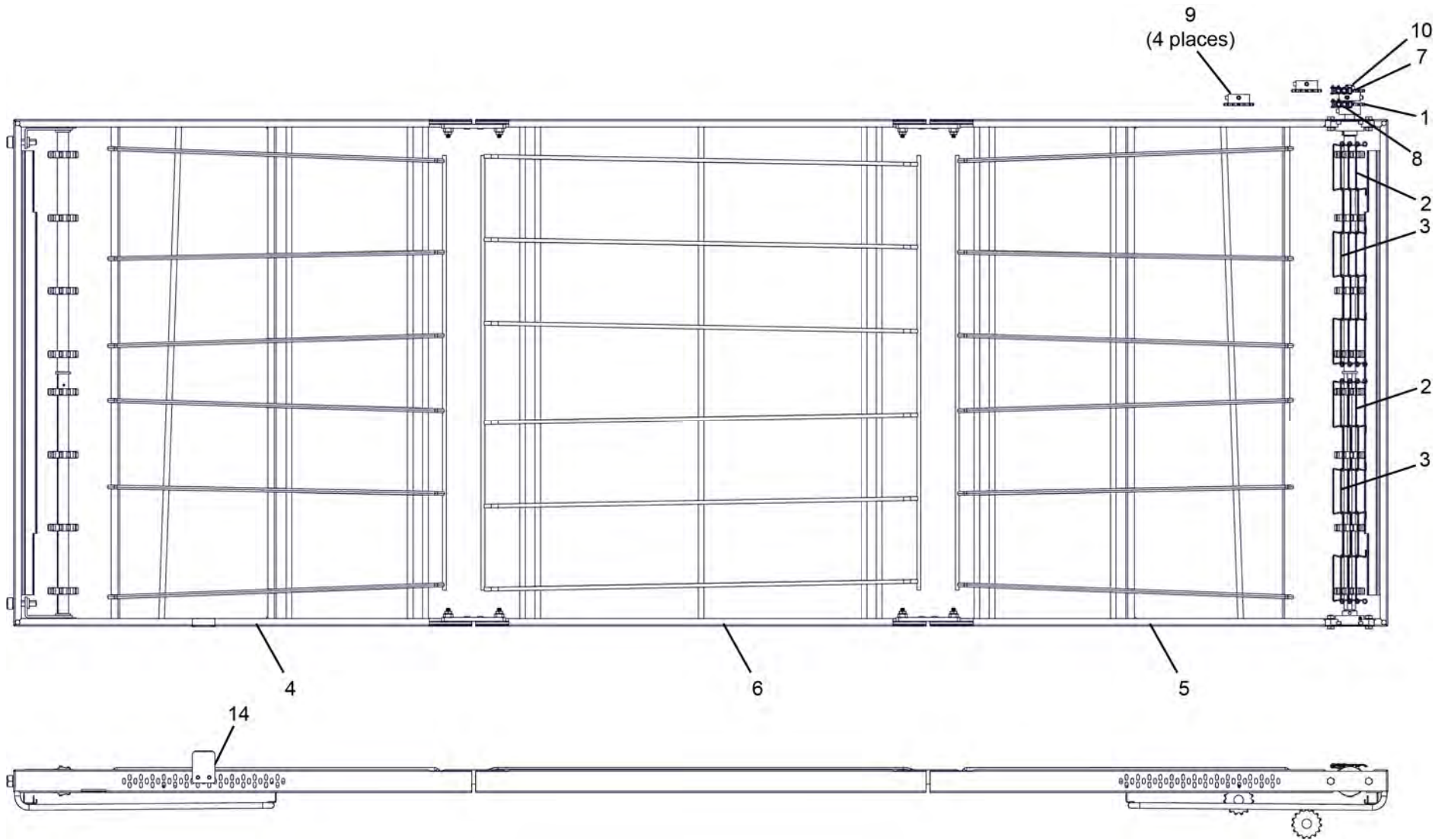

Parts for X55G SPLIT BELT CONVEYOR

| ITEM | QTY. | P/N | DESCRIPTION |
|-------------|------|----------------------------|---------------------------------|
| 1 | 1 | 35000-1531 | SPACER, NYLON |
| 2 | 1 | 79561 | KIT, CONV LINK X55 SPB |
| 3 | 2 | 69646 | BELT, CONV, WIRE SS 1.5"-184.5" |
| 4 | 1 | 69980 | ASSY, CONV FRM/COMPT ID SPB |
| 5 | 1 | 69981 | ASSY, CONV FRM/COMPT DR SPB |
| 6 | 1 | 69105 | WLDMT, CONV CTR FRAME |
| 7 | 1 | 60184 | ASSY, CHAIN ROLLER 14-1/4 |
| 8 | 1 | 60123 | ASSY, CHAIN ROLLER 19-5/8" |
| 9 | 4 | 66581 | SPRKT, #35-15T-5/8 BORE |
| 10 | 1 | 69988 | BUSH, SPROCKET-FRONT DRIVE |
| 11* | 4 | 55486 | SCR, HEX HEAD 1/4-20X 3/4 SS |
| 12* | 1 | 72325 | ADAPTER, MOTOR SHAFT |
| 13* | 4 | 2000049 | SCR, MS TRS HD 6-32X1/2 NP |
| 14 | 1 | 73299 | ASSY, LASER TARGET |
| 15* | 4 | 21426-0002 | WASHER, LOCK SS 1/4 |
| * not shown | | | |

View of X55G SPLIT BELT CONVEYOR IDLER AND DRIVE END ASSEMBLIES

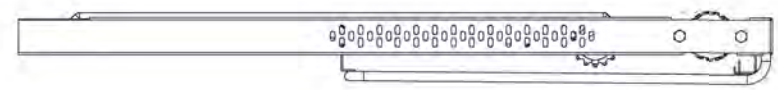
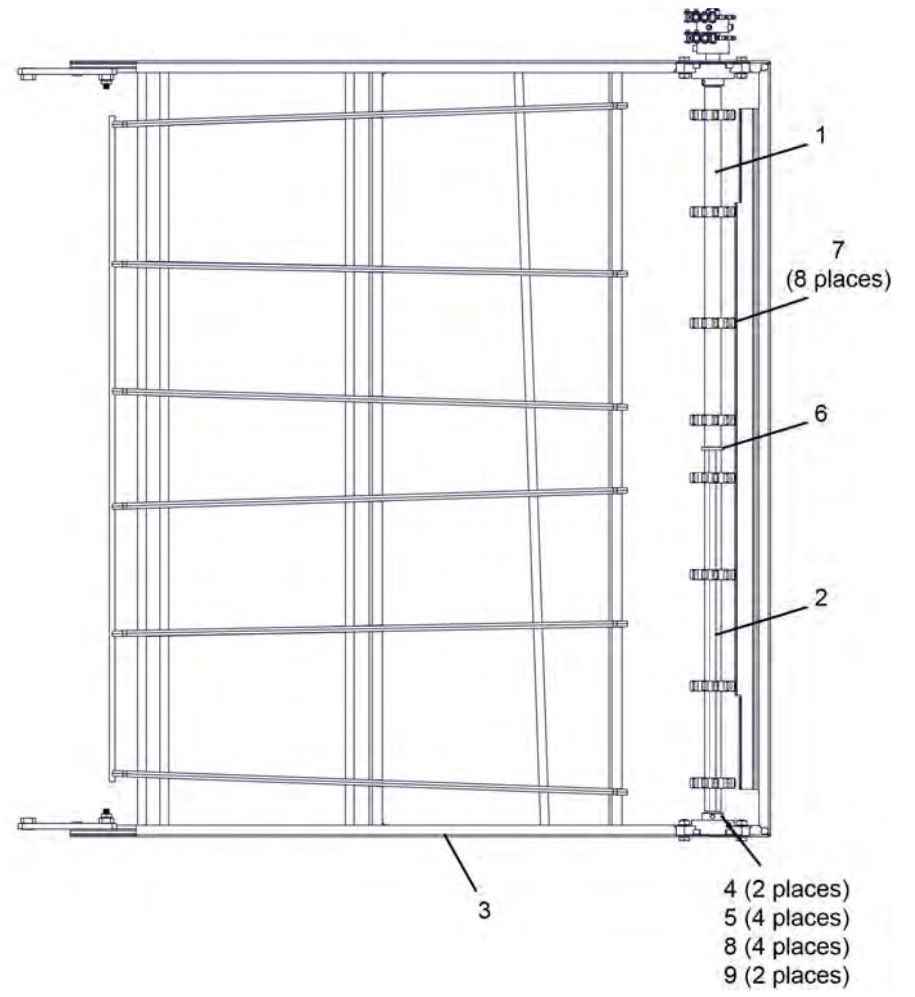
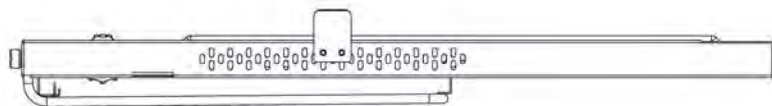
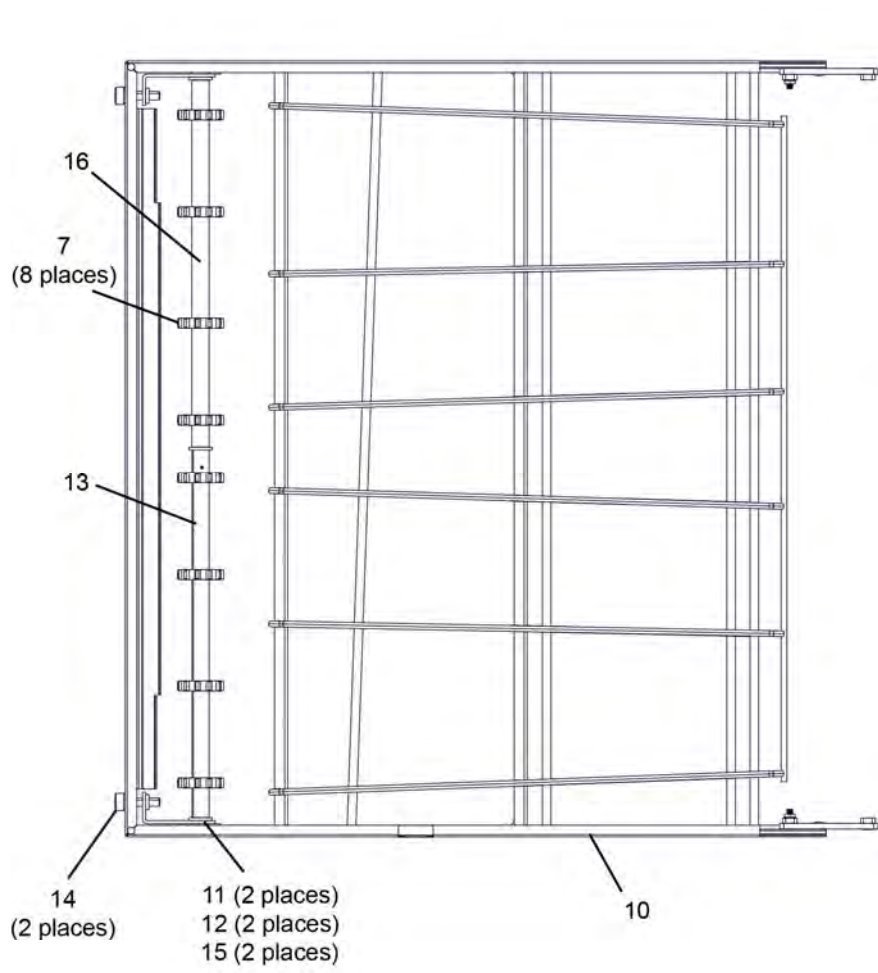

Parts for X55G SPLIT BELT CONVEYOR IDLER AND DRIVE END ASSEMBLIES

| ITEM | QTY. | P/N | DESCRIPTION |
|------|------|----------------------------|--------------------------------|
| 1 | 1 | 60985 | SHAFT, DRIVE REAR SPB |
| 2 | 1 | 69984 | ASSY, DRIVE SHAFT SPB |
| 3 | 1 | 73976 | WLDMT, CONV DRV FRM COMP |
| 4 | 2 | 71178 | BEARING, VF2S-110M BALL |
| 5 | 4 | 75290 | NUT, KEPS 1/4-20SS |
| 6 | 1 | 21415-0001 | WASHER, FLAT BRZ 1 |
| 7 | 16 | 22229-0003 | SPRKT, CONV DRIVE 2.0D W/SCR |
| 8 | 4 | A3333 | SCR, MS HX HD 1/4-20X3/4 18-8 |
| 9 | 2 | 60737 | COVER, BEARING |
| 10 | 1 | 73977 | WLDMT, CONV FRM COMP IDL |
| 11 | 2 | 60179 | BRK, SLIDER CONV |
| 12 | 2 | 37000-0413 | WLDMT, IDLER BRACKET |
| 13 | 1 | 42400-0354 | CONV. IDLER SHAFT FRONT ASSY |
| 14 | 2 | 35000-1008 | SCR, ADJ-CONV IDLER |
| 15 | 2 | 22034-0003 | BUSH, FLANGE 3/4OD X 5/8ID N/D |
| 16 | 1 | 35000-1535 | CONV. IDLER SHAFT REAR |

View of X55WB CONVEYOR SPLIT BELT

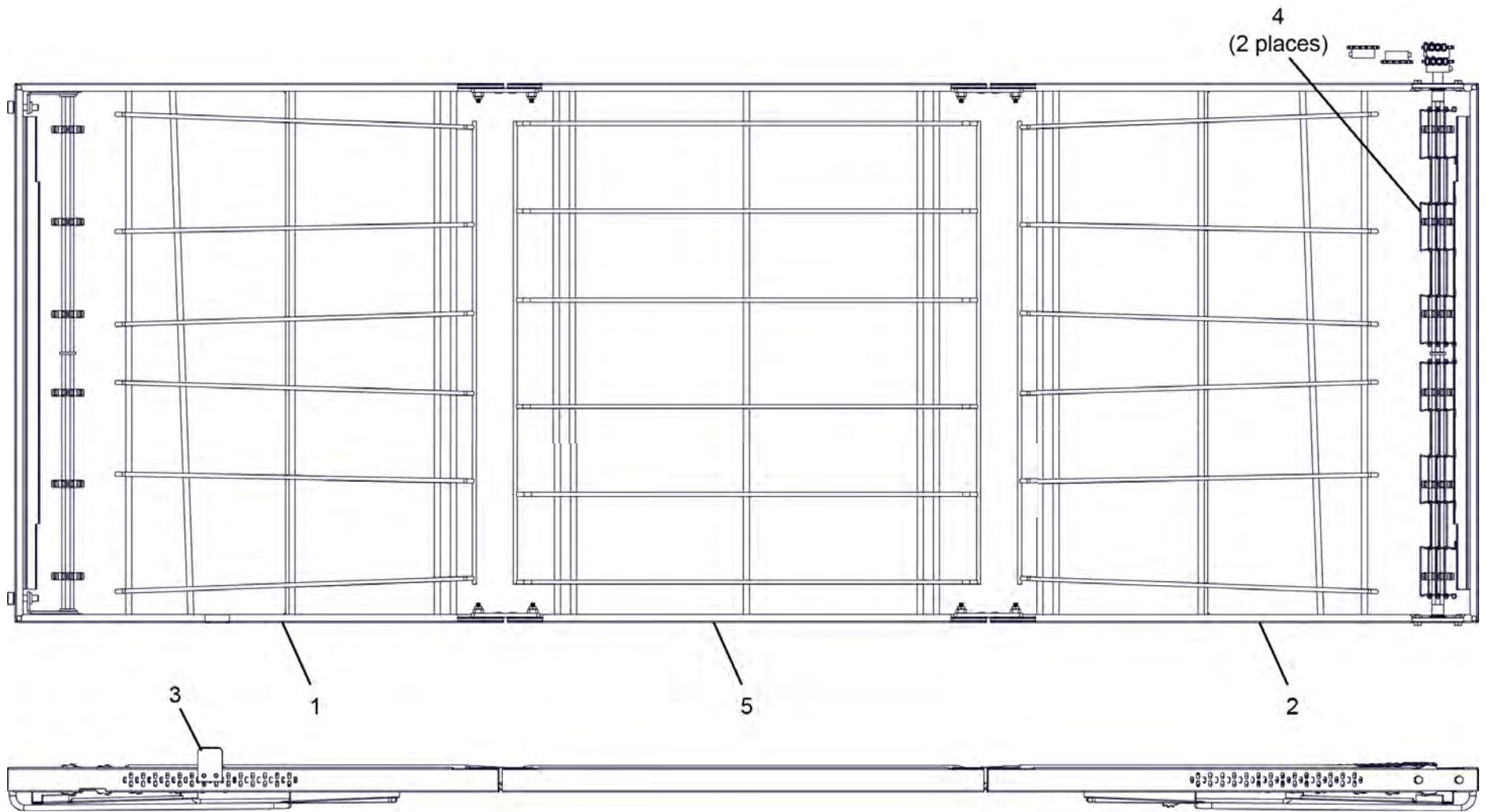

Parts for X55WB CONVEYOR SPLIT BELT

| ITEM | QTY. | P/N | DESCRIPTION |
|------|------|-----------------------|----------------------------|
| 1 | 1 | 78931 | ASSY, CONV IDLER END SPB |
| 2 | 1 | 78930 | ASSY, CONV DRIVE END SPB |
| 3 | 1 | 73299 | ASSY, LASER TARGET |
| 4 | 2 | 71255 | BELT, CONVEYOR 1/2PX18X180 |
| 5 | 1 | 70574 | WLDMT, CONV CTR FRAME |
| | 2 | 79565 | KIT, CONV LINK X55GWB SPB |

View of X55WB CONVEYOR SPLIT BELT IDLER AND DRIVE END ASSEMBLIES

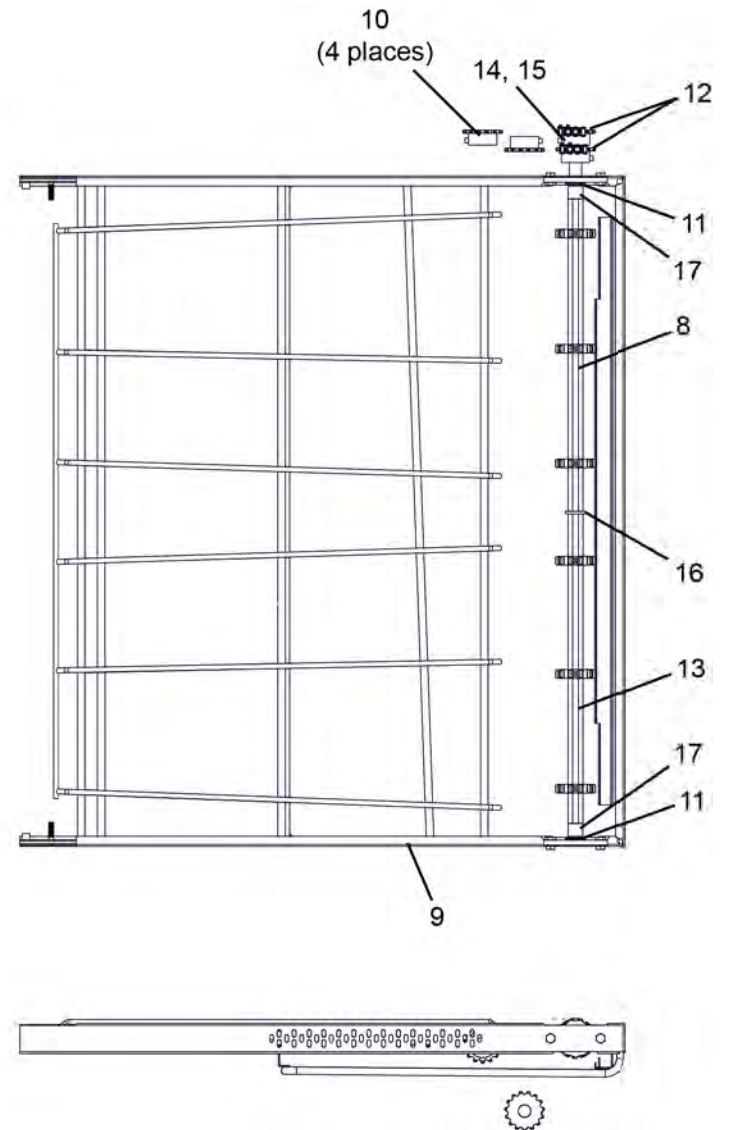
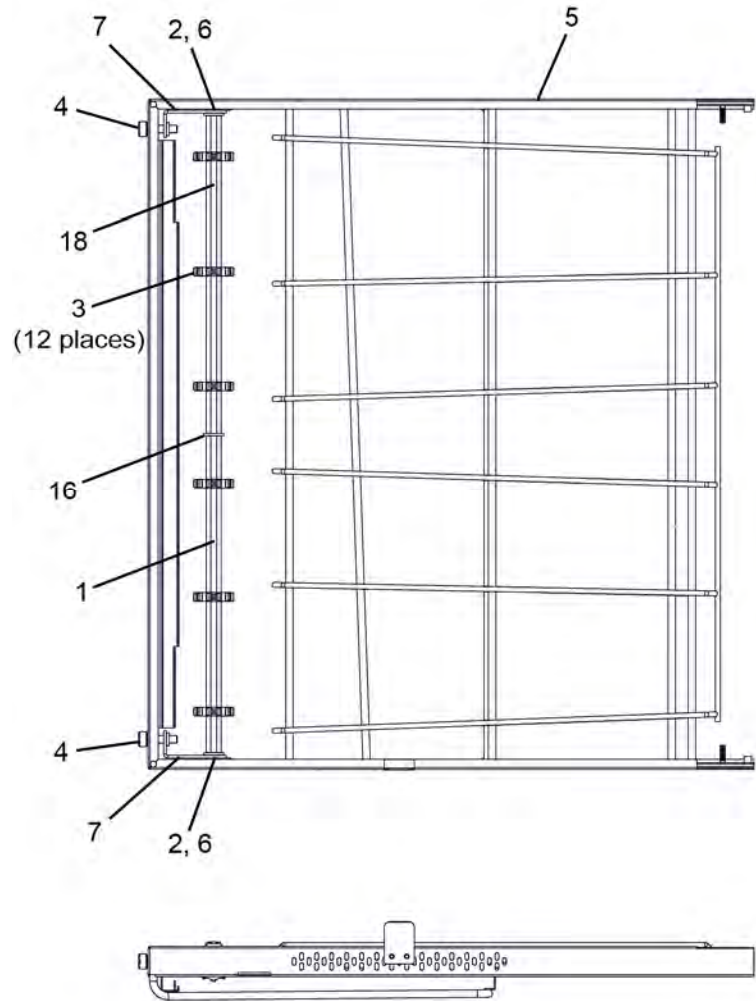

Parts for X55WB CONVEYOR SPLIT BELT IDLER AND DRIVE END ASSEMBLIES

| ITEM | QTY. | P/N | DESCRIPTION |
|------|------|------------|---------------------------------|
| 1 | 1 | 71252 | FRONT CONVEYOR IDLER SHAFT ASSY |
| 2 | 2 | 22034-0003 | BUSH, FLANGE 3/4OD X 5/8ID N/D |
| 3 | 12 | 22229-0003 | SPRKT, CONV DRIVE 2.0D W/SCR |
| 4 | 2 | 35000-1008 | SCR, ADJ-CONV IDLER |
| 5 | 1 | 73761 | WLDMT, CONV FRM COM IDL |
| 6 | 2 | 60179 | BRKT, SLIDER CONV |
| 7 | 2 | 37000-0413 | WLDMT, IDLER BRACKET |
| 8 | 1 | 71246 | ASSY, DRIVE SHAFT FRONT |
| 9 | 1 | 73755 | WLDMT, CONV FRM COMP DRV |
| 10 | 4 | 66581 | SPRKT, #35-15T-5/8 BORE |
| 11 | 2 | 69734 | ASSY, BEARING BLOCK |
| 12 | 2 | 60123 | ASSY, CHAIN ROLLER 19/5/8" |
| 13 | 1 | 71245 | SHAFT, DRIVE REAR SPB |
| 14 | 1 | 69988 | BUSH, SPROCKET-FRONT DRIVE |
| 15 | 1 | 35000-1531 | SPACER, NYLON |
| 16 | 1 | 2145-0001 | WASHER, FLAT BRZ 1 |
| 17 | 2 | 74380 | SPACER, .74OD .64ID .65H |
| 18 | 1 | 71251 | REAR CONVEYOR IDLER SHAFT ASSY |

View of X55WB CONVEYOR SINGLE BELT

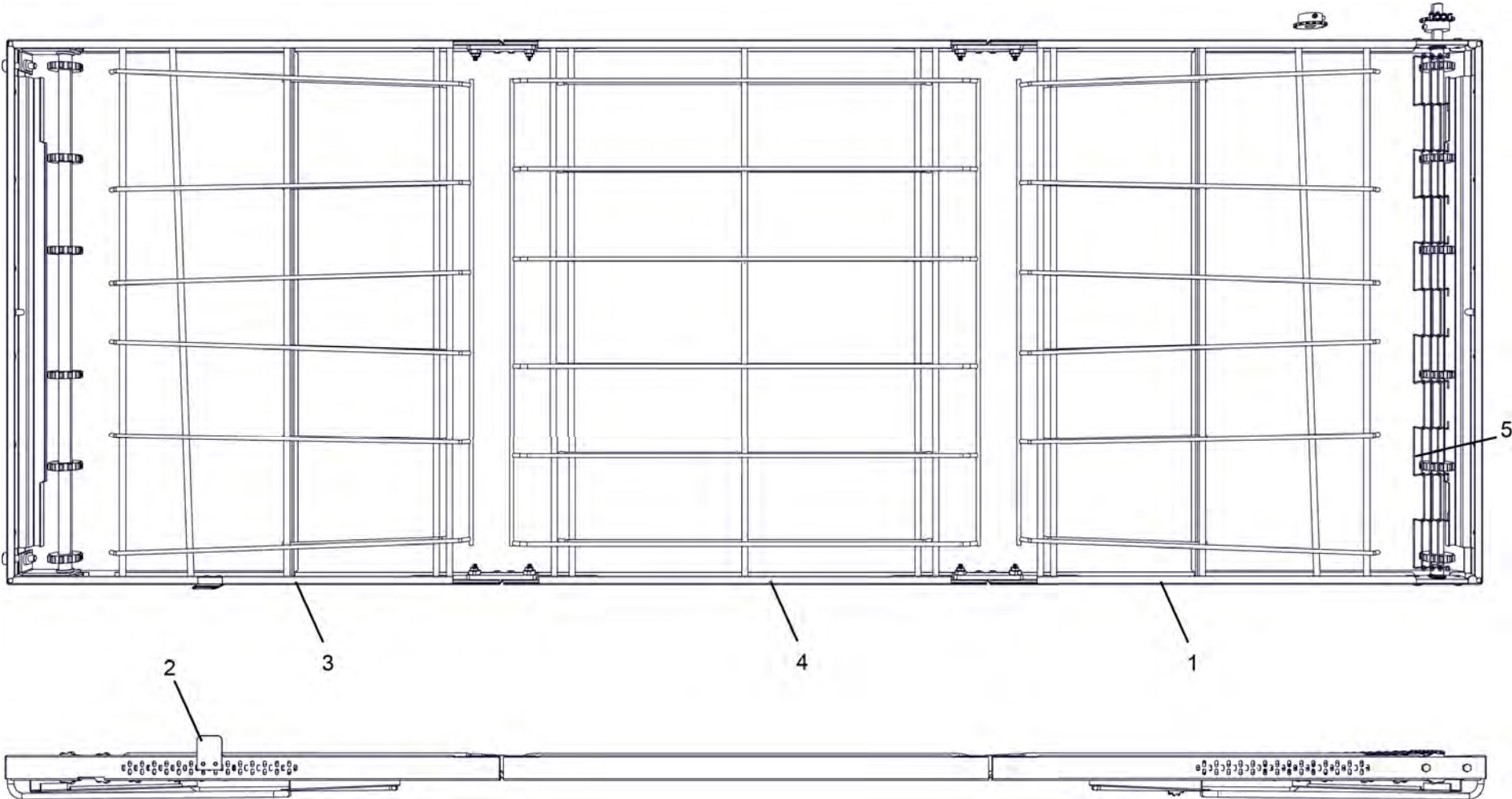

Parts for X55WB CONVEYOR SINGLE BELT

| ITEM | QTY. | P/N | DESCRIPTION |
|------|------|-----------------------|-----------------------------------|
| 1 | 1 | 78388 | ASSY, CONV DRIVE END SIB |
| 2 | 1 | 73299 | ASSY, LASER TARGET |
| 3 | 1 | 70588 | ASSY, CONV FRM/COMPT IDLE |
| 4 | 1 | 70574 | WLDMT, CONV CTR FRAME |
| 5 | 1 | 70571 | BELT, CONV 1/2P X 37X180 2.43/15S |
| | 1 | 79566 | KIT, CONV LINK X55 SIB GWB |

View of X55WB CONVEYOR SINGLE BELT IDLER AND DRIVE END ASSEMBLIES

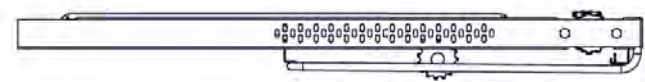
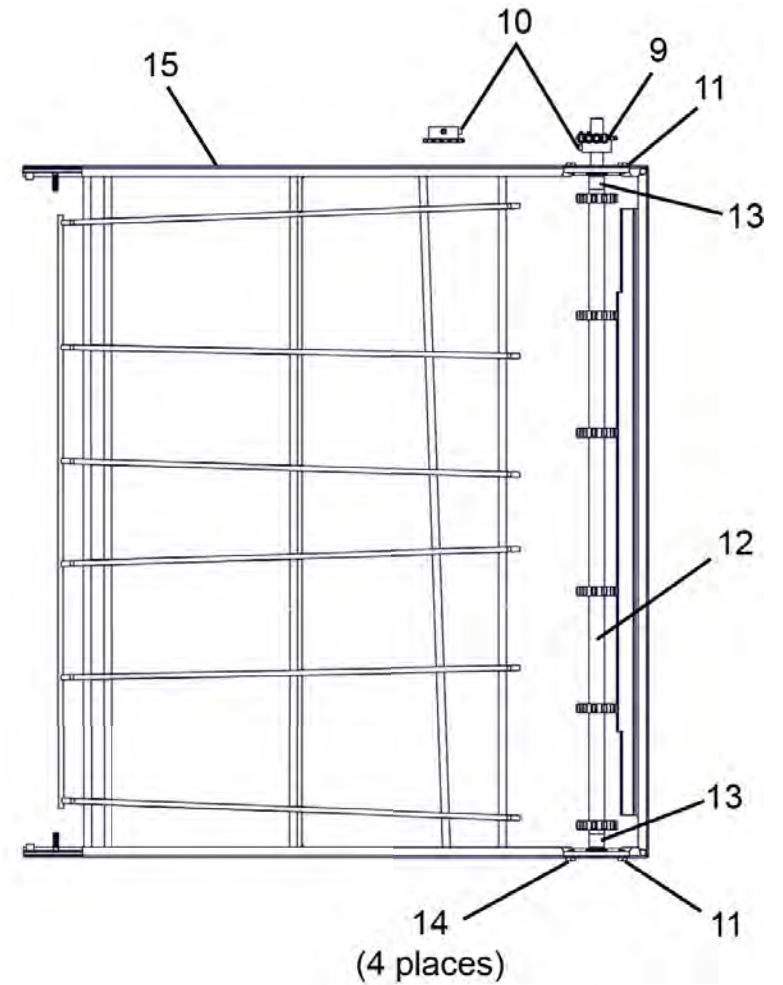
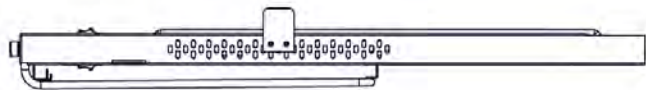
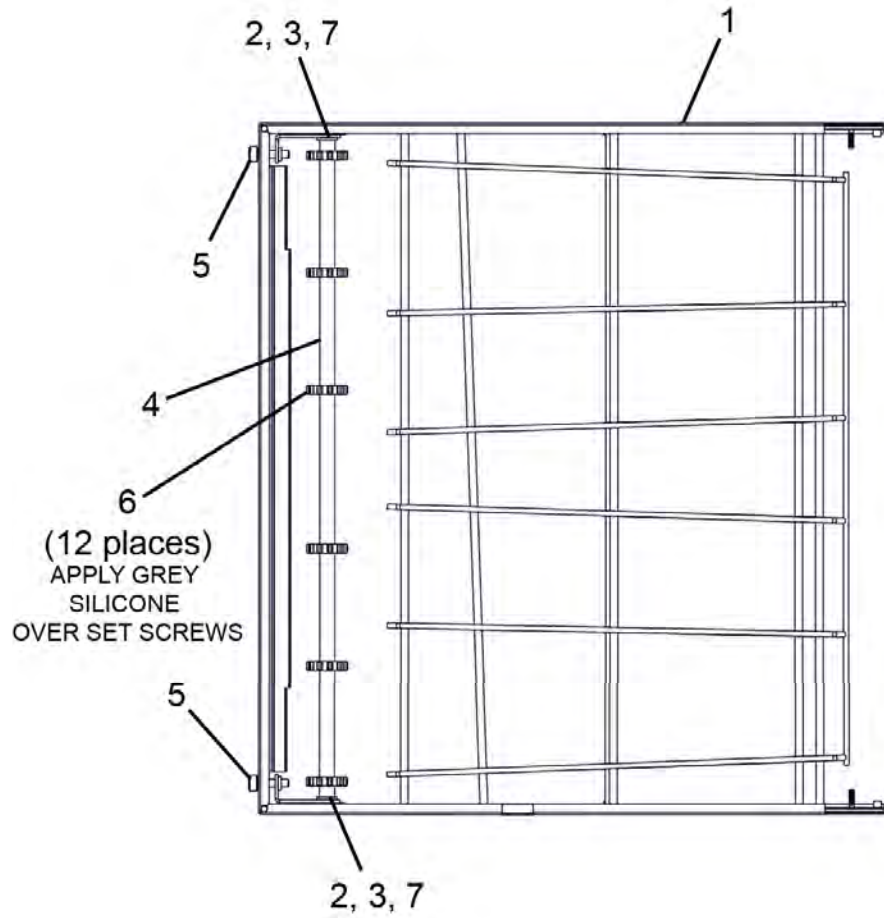

Parts for X55WB CONVEYOR SINGLE BELT IDLER AND DRIVE END ASSEMBLIES

| ITEM | QTY. | P/N | DESCRIPTION |
|-------------|-------|------------|--------------------------------|
| 1 | 1 | 73761 | WLDMT, CONV FRM COM IDL |
| 2 | 2 | 60179 | BRKT, SLIDER CONV |
| 3 | 2 | 37000-0413 | WLDMT, IDLER BRACKET |
| 4 | 1 | 70587 | SHAFT, IDLER-CONV |
| 5 | 2 | 35000-1008 | SCR, ADJ-CONV IDLER |
| 6 | 12 | 22229-0003 | SPRKT, CONV DRIVE 2.0D W/SCR |
| 7 | 2 | 22034-0003 | BUSH, FLANGE 3/4OD X 5/8ID N/D |
| 8* | .001 | 2700058 | TUBING, GREY SILICONE |
| 9 | 1 | 60123 | ASSY, CHAIN ROLLER 19/5/8" |
| 10 | 2 | 66581 | SPRKT, #35-15T-5/8 BORE |
| 11 | 2 | 69734 | ASSY, BEARING BLOCK |
| 12 | 1 | 71238 | SHAFT, DRIVE-CONV |
| 13 | 2 | 74380 | SPACER, .74OD .64ID .65H |
| 14 | 4 | M0474 | SCR, MS HEX HD 1/4-20X3/8 |
| 15 | 1 | 73755 | WLDMT, CONV FRM COMP DRV |
| 16* | 0.001 | M7972 | SEALANT, RTV |
| * not shown | | | |

View of X55 70/30 SPLIT BELT CONVEYOR

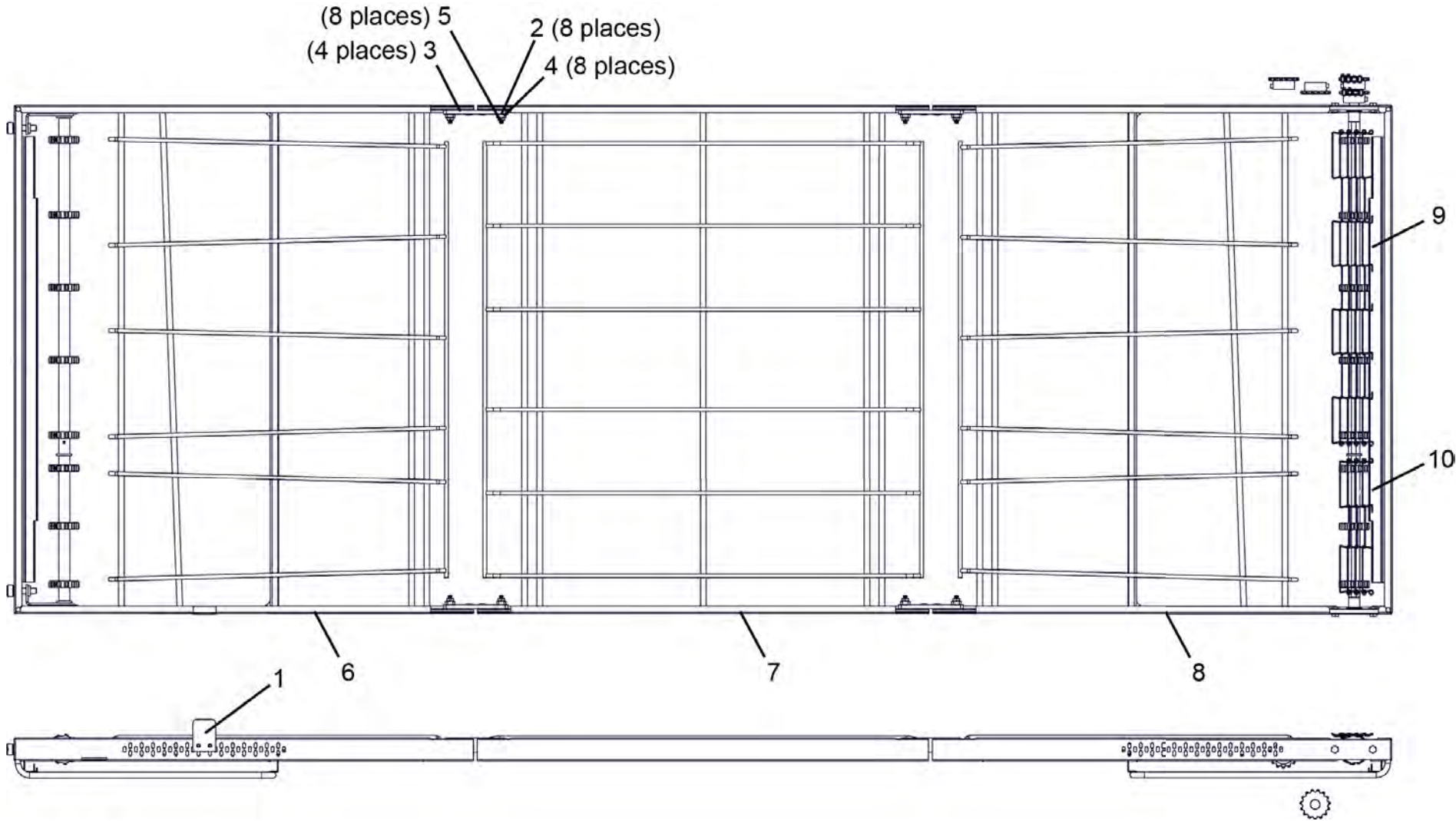

Parts for X55 70/30 SPLIT BELT CONVEYOR

| ITEM | QTY. | P/N | DESCRIPTION |
|------|------|------------|-------------------------------|
| 1 | 2 | 73299 | ASSY, LASER TARGET |
| 2 | 8 | F716A8805 | WASHER, LOCK EXT 1/4" ZPS |
| 3 | 4 | 35210-0429 | PLATE, PIVOT-CONV PS570 |
| 4 | 8 | 21176-0001 | NUT, LOCK HEX SS 1/4-20 |
| 5 | 8 | 35210-0491 | BUSHING, CONV, ADJ |
| 6 | 1 | 79359 | ASSY, CONV. IDLER END SPB |
| 7 | 1 | 69105 | WLDMT, CONV. LTR FRAME |
| 8 | 1 | 79358 | ASSY, CONV. DRIVE END SPB |
| 9 | 1 | 79365 | BELT, CONV. 1/2P X 21 X 184.5 |
| 10 | 1 | 79364 | BELT, CONV. 1/2P X 9 X 184.5 |
| | 1 | 79562 | KIT, CONV LINK X55 70/30 SPB |

View of X55 70/30 SPLIT BELT CONVEYOR IDLER AND DRIVE END ASSEMBLIES

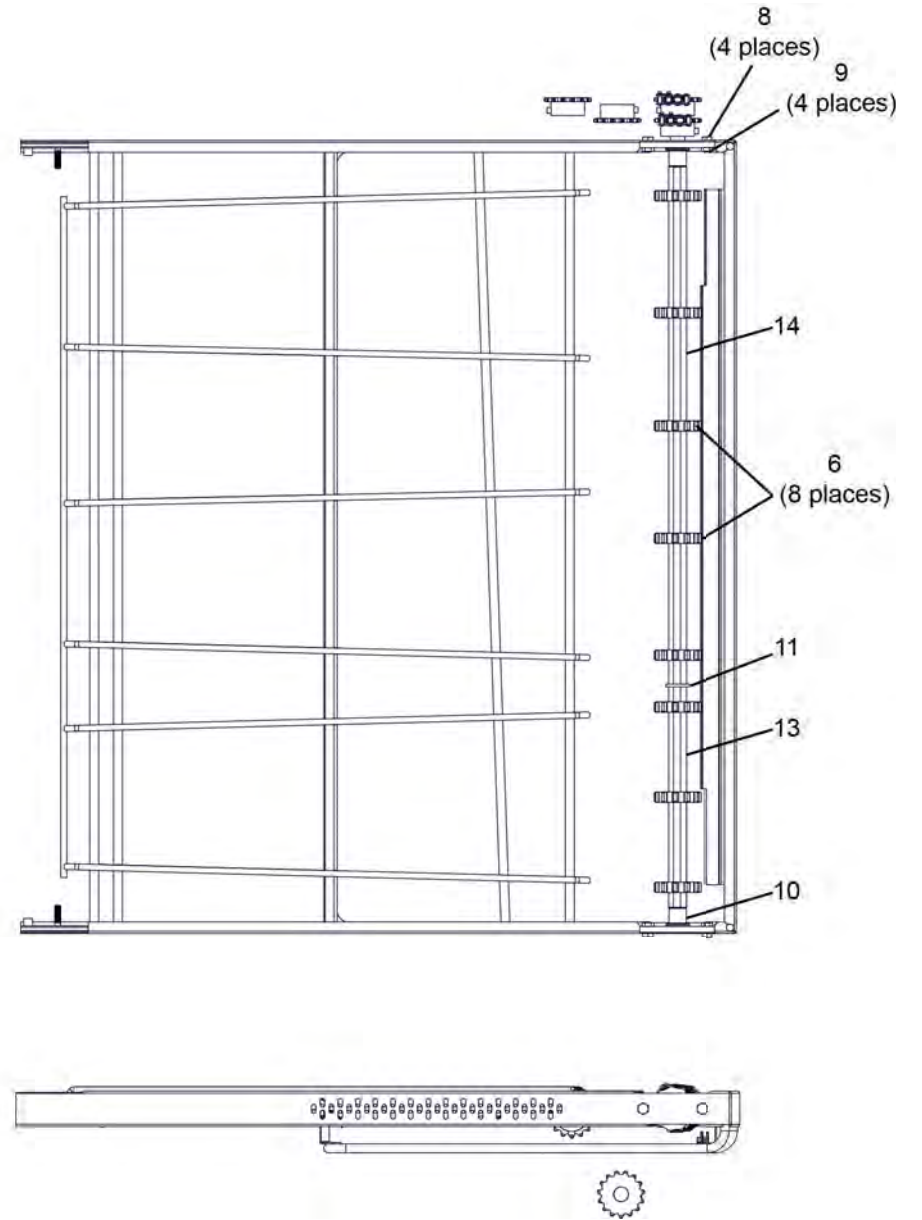
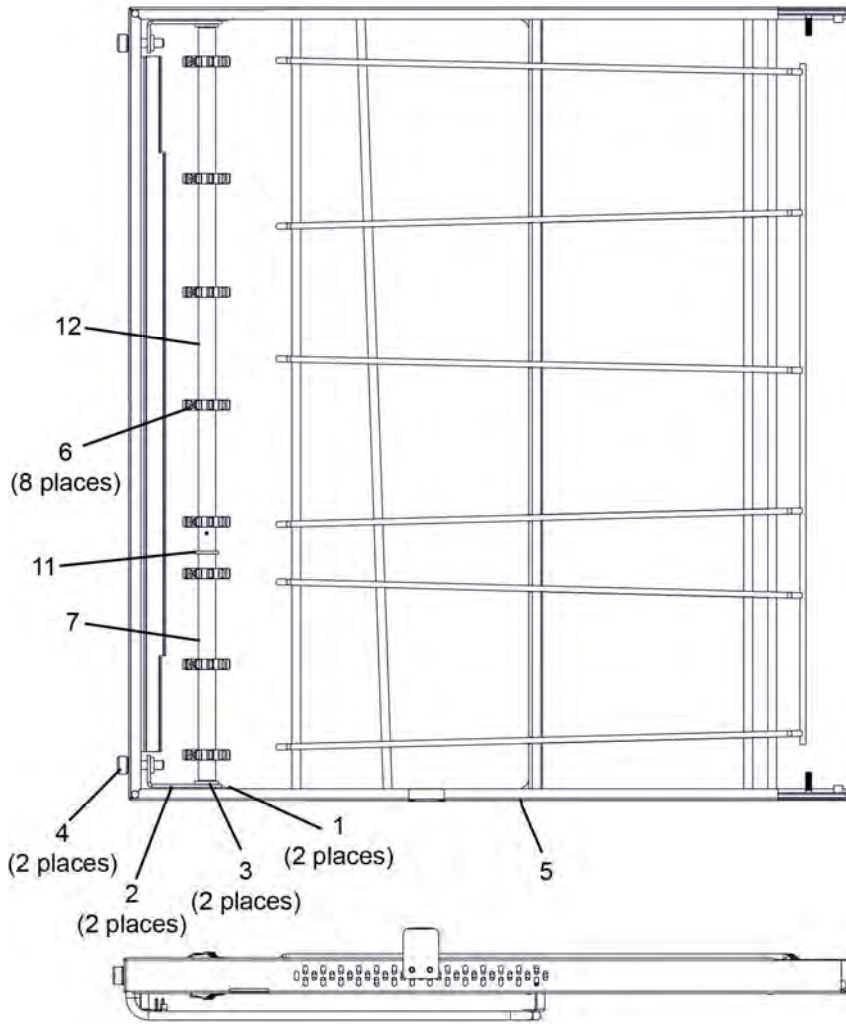

Parts for X55 70/30 SPLIT CONVEYOR IDLER AND DRIVE END ASSEMBLIES

| ITEM | QTY. | P/N | DESCRIPTION |
|------|------|------------|-----------------------------------|
| 1 | 4 | 60179 | BRKT, SLIDER CONV |
| 2 | 2 | 37000-0413 | WLDMT, IDLER BRACKET |
| 3 | 2 | 22034-0003 | BUSH, FLANGE 3/4 OD X 5/8 ID, N/D |
| 4 | 2 | 35000-1008 | SCR, ADJ-CONV IDLER |
| 5 | 1 | 79360 | WLDMT, CONV FRM COMP IDL |
| 6 | 16 | 22229-0003 | SPRKT, CONV. DRIVE 2.0D W/SCR |
| 7 | 1 | 79352 | SHAFT, REAR CONV. IDLER |
| 8 | 4 | A6153 | SCR, MS HH 1/4-20 X X1/2 18-8 |
| 9 | 4 | 21176-0001 | NUT, LOCK HEX SS 1/4-20 |
| 10 | 2 | 74380 | SPACER, 0.74OD, 0.64ID, 0.65H |
| 11 | 1 | 21415-0001 | WASHER, FLAT BRZ 1 |
| 12 | 1 | 79354 | SHAFT, FRONT CONV. IDLER ASSY |
| 13 | 1 | 79326 | SHAFT, FRONT CONV. DRIVE ASSY |
| 14 | 1 | 79325 | SHAFT, REAR CONV. DRIVE |

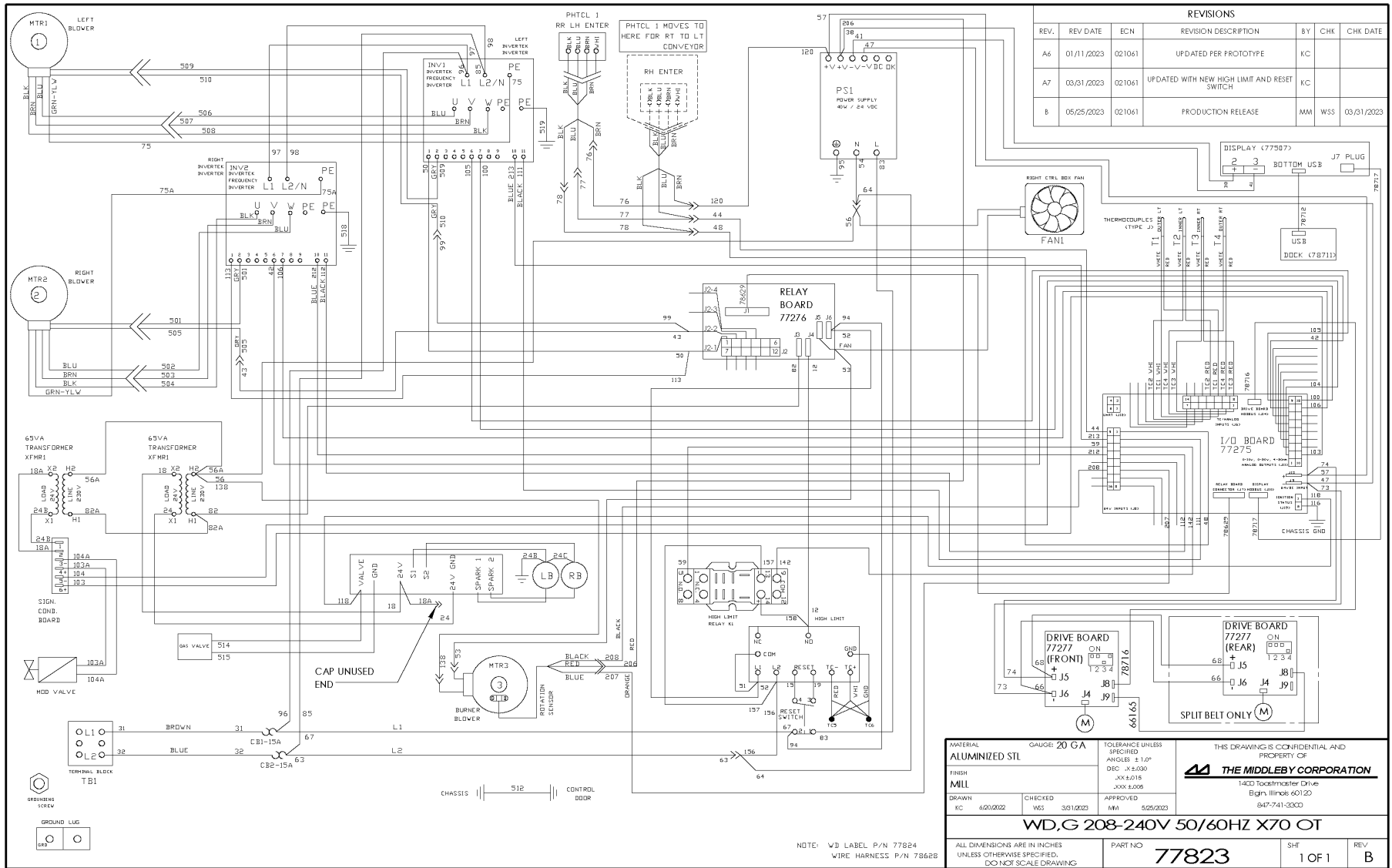

| REVISIONS | | | | | |
|-----------|------------|--------|--|----|----------------|
| REV. | REV DATE | ECN | REVISION DESCRIPTION | BY | CHK DATE |
| A6 | 01/11/2023 | 021061 | UPDATED PER PROTOTYPE | KC | |
| A7 | 03/31/2023 | 021061 | UPDATED WITH NEW HIGH LIMIT AND RESET SWITCH | KC | |
| B | 05/25/2023 | 021061 | PRODUCTION RELEASE | MM | WSS 03/31/2023 |

| | | | | | | | |
|---|-----------------------|--------------------------|---------------------------|---|---------------|---|--|
| MATERIAL ALUMINIZED STL | | GAUGE: 20 GA | | TOLERANCE UNLESS SPECIFIED ANGLES ± 1.0° DEC ± 0.030 XX ± 0.015 XXX ± 0.006 | | THIS DRAWING IS CONFIDENTIAL AND PROPERTY OF THE MIDDLEBY CORPORATION 1400 Toolmaster Drive Bryn Illinois 60120 847-741-3300 | |
| FINISH MILL | DRAWN KC 6/20/2022 | CHECKED VSS 3/31/2023 | APPROVED NMA 5/25/2023 | WD,G 208-240V 50/60HZ X70 OT | | | |
| ALL DIMENSIONS ARE IN INCHES UNLESS OTHERWISE SPECIFIED. DO NOT SCALE DRAWING. | | | | PART NO 77823 | SHF 1 OF 1 | REV B | |

MIDDLEBY MARSHALL X70G WIRING DIAGRAM G208-240 volt 50/60 Hz, 1 Phase

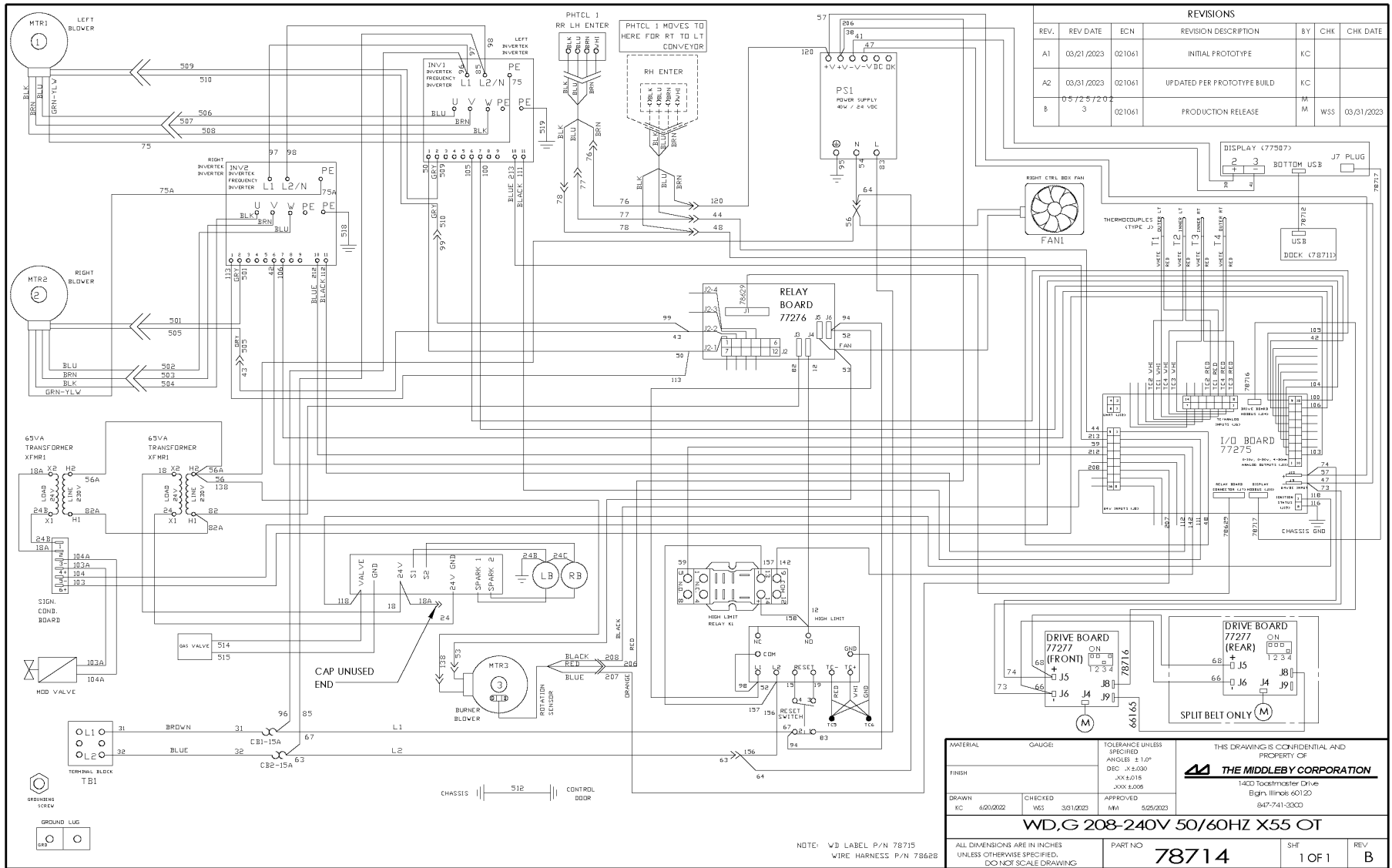

MIDDLEBY MARSHALL X55G/x55GWB WIRING DIAGRAM G208-240 volt 50/60 Hz, 1 Phase

NOTES

NOTES

NOTES