

DV 80.2/80.2 WAHR

Door-type high temperature sanitizing dishwasher

Installation, Operation and Maintenance manual



CAUTION - Before using the machine, read the Operation, Product Description and Safety sections carefully

Contents

| | | |
|----------|--|-----------|
| 1 | NOTES ON THE OPERATING INSTRUCTIONS | 5 |
| 1.1 | Product identification | 5 |
| 1.2 | Delivery contents | 5 |
| 1.3 | Related documents | 5 |
| 1.4 | Illustration | 6 |
| 1.4.1 | <i>Warnings</i> | 6 |
| 1.4.2 | <i>Notices on use</i> | 6 |
| 1.4.3 | <i>Safety symbols in the instructions</i> | 7 |
| 2 | GUARANTEE | 7 |
| 3 | SAFETY | 7 |
| 3.1 | Intended use | 7 |
| 3.2 | Misuse | 7 |
| 3.3 | Safety information | 8 |
| 3.4 | What to do in the event of an emergency | 10 |
| 3.5 | Safety notices on the machine | 10 |
| 3.6 | Requirements for the personnel | 10 |
| 3.7 | Electromagnetic compatibility | 12 |
| 4 | PRODUCT DESCRIPTION | 12 |
| 4.1 | Functional description | 12 |
| 4.2 | Overview illustration | 13 |
| 4.3 | Membrane keypad | 13 |
| 4.4 | Wash programs | 15 |
| 4.5 | Rating plate | 15 |
| 4.6 | Detergent and rinse aid | 17 |
| 4.6.1 | <i>Detergent</i> | 17 |
| 4.6.2 | <i>Rinse aid</i> | 17 |
| 4.6.3 | <i>Checking the correct dosing settings</i> | 18 |
| 4.6.4 | <i>Dosing units</i> | 18 |
| 4.6.5 | <i>Change of products</i> | 18 |
| 4.7 | Additional equipment | 19 |
| 5 | TECHNICAL DATA | 19 |
| 6 | TRANSPORT..... | 20 |

| | | |
|-----------|--|-----------|
| 7 | REQUIREMENTS FOR INSTALLATION..... | 21 |
| 7.1 | Requirements for the installation location | 21 |
| 7.2 | Requirements for the wastewater connection | 21 |
| 7.3 | Requirements for the fresh water connection | 22 |
| 7.4 | Requirements for the electrical connection | 23 |
| 8 | INSTALLATION..... | 24 |
| 8.1 | Accessing the utility connections | 24 |
| 8.2 | Electrical installation | 25 |
| 8.3 | Connecting the fresh water pipe | 28 |
| 8.4 | Connecting the wastewater pipe | 29 |
| 8.5 | Connection for wastewater temperature control (optional) | 30 |
| 8.6 | Install waste air heat recovery (WAHR option) | 31 |
| 8.6.1 | <i>Parts supplied for installation</i> | 31 |
| 8.6.2 | <i>Installation</i> | 31 |
| 8.7 | Connecting the dosing system | 36 |
| 8.8 | Connecting the detergent and rinse aid canisters | 37 |
| 8.9 | Tabling attachment | 38 |
| 8.10 | Terminating the installation | 41 |
| 9 | COMMISSIONING | 41 |
| 9.1 | Checking the requirements for commissioning | 41 |
| 9.2 | Performing commissioning | 42 |
| 9.3 | Venting (priming) the pipes | 42 |
| 10 | OPERATION/USE | 43 |
| 10.1 | Prior to switching on the machine | 43 |
| 10.1.1 | <i>Starting up the dishwasher</i> | 45 |
| 10.2 | Washing | 45 |
| 10.2.1 | <i>Useful information for loading the washware</i> | 45 |
| 10.2.2 | <i>Selecting the wash program</i> | 46 |
| 10.2.3 | <i>Starting the wash cycle</i> | 47 |
| 10.2.4 | <i>Unloading the washware</i> | 48 |
| 10.3 | Switching off the machine | 49 |
| 10.4 | Replacing the canisters | 50 |
| 10.4.1 | <i>Replacing the canisters</i> | 50 |
| 10.5 | Malfunctions | 51 |

| | | |
|-----------|---|-----------|
| 10.5.1 | Messages | 52 |
| 10.6 | Modifying the settings | 56 |
| 10.7 | Level 1 | 57 |
| 10.7.1 | Viewing the parameters | 57 |
| 10.7.2 | Venting (priming) the pipes | 58 |
| 10.8 | Level 2 | 59 |
| 11 | CLEANING | 60 |
| 11.1 | Cleaning the interior | 60 |
| 11.2 | Cleaning the membrane keypad | 61 |
| 11.3 | Cleaning the outer stainless steel surfaces | 62 |
| 11.4 | Cleaning the surrounding area | 62 |
| 11.5 | Descaling | 62 |
| 12 | MAINTENANCE | 63 |
| 12.1 | Maintenance work | 65 |
| 12.2 | Maintenance table | 65 |
| 13 | DISMANTLING AND DISPOSAL..... | 67 |
| 13.1 | Disposal of packaging materials | 67 |
| 13.2 | Dismantling and disposal of the old machine | 67 |
| 14 | INDEX | 69 |
| 15 | NOTES..... | 71 |

1 Notes on the operating instructions

The operating instructions as well as the applicable documents must be read before initial commissioning, kept for later use, and be accessible to the operator at all times. Failure to observe the operating instructions may result in damage to persons and property.

These operating instructions can be downloaded at the following address: **www.meiko.us** or <https://partnetnet.meiko-global.com>.

1.1 Product identification

These operating instructions apply to the following machine types:

- Door-type dishwasher DV 80.2 / DV 80.2 WAHR

1.2 Delivery contents

- Door-type dishwasher DV 80.2 / DV 80.2 WAHR
- Matching racks for glassware and dishes depending on machine model
- Connection hoses for fresh water and wastewater
- Documentation

1.3 Related documents

In addition to these operating instructions, there are other documents:

- Short operating instructions
- Wiring diagram (behind the lower front panel)
- Data sheet with technical data and dimensions

1.4 Illustration

1.4.1 Warnings



WARNING – indicates a potentially hazardous situation which, if not avoided, could result in serious injury or death.



CAUTION – indicates a possible hazardous situation which, if not avoided, could result in minor or moderate injury or damage to property.

1.4.2 Notices on use

NOTE – indicates a possible hazardous situation which could result in damage to property.







IMPORTANT – indicates useful information about the product or its use.

Notes on using the document:

- A bullet point (•) indicates a list.
- Numerals (1.) indicate several action steps that must be executed in the specified order.
- Position numbers in the text that refer to position numbers in figures are shown in parentheses:
(1) Position number 1 in the figure
- The text is always below the figure and refers to it until a new image follows.

1.4.3 Safety symbols in the instructions

| | | | |
|---|-----------------------------------|---|---------------------------------------|
|  | Read the operating instructions |  | Disconnect from the power supply |
|  | Potential equalization connection |  | Warning of dangerous electric voltage |
|  | Manufacturer | | |

2 Guarantee

FOR WARRANTY ACTIVATION, please contact your authorized MEIKO service partner.

For an ASA listing, please refer to either the QR code on the back cover of this manual or visit our website at www.meiko.us. You may also contact MEIKO service directly at (800) 868-3840.

You will be asked to schedule your performance and installation inspection. This inspection is provided FREE OF CHARGE to ensure that your new dishwasher is properly installed.

YOUR GUARANTEE IS NOT VALID UNTIL THIS FREE INSPECTION HAS BEEN COMPLETED BY YOUR AUTHORIZED SERVICE AGENCY.

3 Safety

Read and observe all safety information, instructions and symbols attached to the product. Improper use may result in damage to the product or danger to the user.

3.1 Intended use

The dishwasher is intended for commercial use only and is designed to wash dishes, cutlery, glasses, kitchen utensils, baking sheets, and containers. The washware must be suitable for commercial dishwashers.

3.2 Misuse

The dishwasher must not be used for:

- Washing kitchen utensils with electrical components
- Cleaning textiles, oven cloths or steel sponges
- Washing utensils made of iron or utensils that must not come into contact with foodstuff (e.g. ashtrays, candlesticks, etc)
- Cleaning living creatures
- Washing food for subsequent consumption
- Preparing foodstuff in the machine
- Taking wash water to prepare food or for drinking
- Washing support grids of electric ranges / grills of gas ranges
- Filling the machine from an external source (e.g. shower)
- Disposing of dirty water using the dishwasher (e.g. from a cleaning bucket)
- Standing or sitting on machine parts (e.g. door)
- Washing dishes made of wood or dishes that have wooden parts
- Washing plastic parts that are not resistant to heat and alkaline solution
- Washing parts made of aluminum (pots, containers, or trays, for example, with a suitable detergent only to avoid black discoloration)
- Conversions and modifications by means of non-approved conversion kits

3.3 Safety information

- Do not open the door while the program is running.
- Only operate the dishwasher when it is in perfect working order. All protection devices and housing parts as well as the tank cover sieve must be installed.
- Place washware, in particular small items, in the appropriate rack inserts.
- The washware must not come into contact with the wash arms/rinse arms of the dishwasher.
- Wear suitable work clothing, protective gloves and sturdy shoes.
- Do not wear rings, necklaces or other pieces of jewelry.
- Connect the suction lances of the dishwasher correctly to the canisters.
- Use optional bought-in parts in accordance with the associated instructions.

Electrical connection, see page 25.

- The power supply must be fused in accordance with the regulations and a lockable main switch provided in the local electrical installation.

- The electrical safety of this machine is only ensured if it is connected to a properly installed protective conductor system. It is very important to verify this fundamental safety feature. If in doubt, have the building wiring checked by an electrically skilled person.
- Carry out the protective measures as well as the equipotential bonding connection in accordance with the regulations of the local power supply companies as well as the locally applicable regulations.

Fresh water connection

- Installation components must be suitable and permitted in accordance with local regulations.
- Turn off the shut-off valve of the fresh water supply line before carrying out installation work. Check that all lines are securely connected and tight.
- When replacing an old machine with a new one, make sure that the existing feed hose is exchanged for the new feed hose supplied with the machine.

Environment

- Do not remove safety and warning notices from the dishwasher and ensure they are legible. Replace any damaged safety and warning notices.
- Do not process hazardous substances (hazardous to health, especially toxic, highly flammable and explosive substances) in the machine.
- Do not operate the dishwasher in a potentially explosive atmosphere.

Maintenance and repair

- Observe the maintenance specifications and intervals, including those of optional bought-in parts.
- Only use original spare parts from the manufacturer.
- Before opening the housing parts, ensure the local main switch has been disconnected from power and secured so that it cannot be switched on again.

Conversions

- Installation of an external dosing system is possible. Other modifications to the machine are not permissible.
- The safety of the dishwasher must not be impaired by the subsequent installation of a dosing system. Only use dosing technology approved by MEIKO.

3.4 What to do in the event of an emergency



- In dangerous situations, disconnect the machine from the power supply using the available main switch.

3.5 Safety notices on the machine

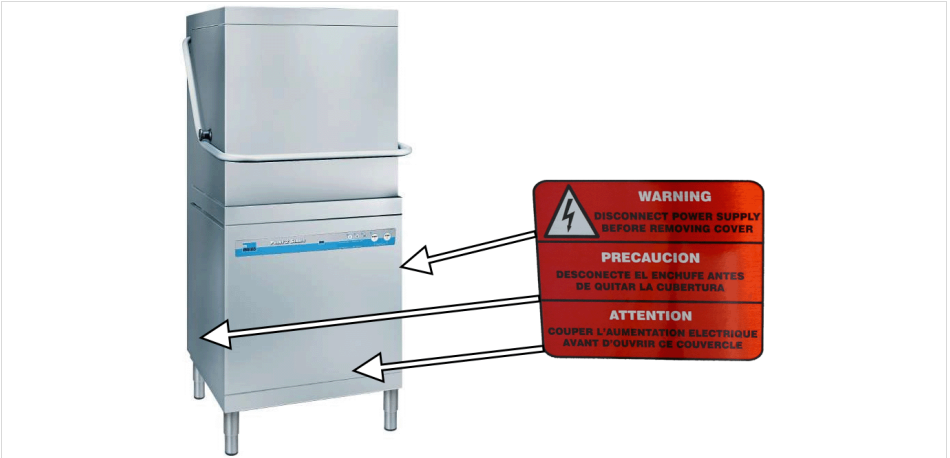

The safety notice is located on the left/right side panel and on the front panel.

3.6 Requirements for the personnel

Installation, commissioning, instruction, repairs and maintenance of MEIKO products may only be carried out by authorized service partners.

The operator must check the area around the machine or system for hazards to other persons, e.g. children or persons with reduced physical, sensory or mental capabilities, or with a lack of experience or knowledge.

During operation it must be ensured that:

- Only adequately trained and instructed personnel are allowed to work on the machine.
- Personnel responsibilities for operation, maintenance and repairs must be clearly defined.
- Any personnel undergoing training are only allowed to work on the machine under the supervision of an experienced person.
- No person is under the influence of alcohol, drugs or medication (perceptual disorder).

The required qualifications for performing specific work on the machine are determined by MEIKO:

| Persons | Trained operating personnel | In-house technician authorized by MEIKO | Service technician authorized by MEIKO |
|-----------------------------|------------------------------------|--|---|
| Activity | | | |
| Operation, use | ✓ | ✓ | ✓ |
| Cleaning | ✓ | ✓ | ✓ |
| Checking safety devices | | ✓ | ✓ |
| Troubleshooting | ✓ | ✓ | ✓ |
| Troubleshooting, mechanical | ✓ | ✓ | ✓ |
| Troubleshooting, electrical | | ✓* | ✓ |
| Maintenance | | ✓ | ✓ |
| Repairs | | ✓ | ✓ |

* When trained as an electrically skilled person



Note

The instructions must be acknowledged in writing.

Qualified personnel, as defined by these operating instructions, are persons who:

- Are over 14 years of age.
- Due to their training, experience and instruction are able to perform the required activities.
- Are authorized to perform the required activities by the person responsible for safety of the machine.
- Have read and understood the operating instructions and corresponding safety information and will follow them.

3.7 Electromagnetic compatibility



NOTE:

This equipment has been tested and found to comply with the limits for a Class A digital device, pursuant to part 15 of the FCC Rules. These limits are designed to provide reasonable protection against harmful interference when the equipment is operated in a commercial environment.

This equipment generates, uses, and can radiate radio frequency energy and, if not installed and used in accordance with the instruction manual, may cause harmful interference to radio communications. Operation of this equipment in a residential area is likely to cause harmful interference in which case the user will be required to correct the interference at his own expense.

4 Product description

4.1 Functional description

The dishwasher has one wash cycle and one final rinse cycle.

A temperature controller keeps the set wash temperature at 155°F (66°C), minimum. A rotary pump circulates the water from the wash tank into the wash nozzles. The water jets hit the washware from different directions. This ensures uniform washing results.

The wash cycle is followed by a fresh water final rinse. A separate nozzle system rinses the washware using hot fresh water with at least 180°F (82°C). This heats up the washware for the subsequent drying process.

At the same time, the rinse water is used to regenerate the wash water; this reduces the degree of soiling of the wash water.

4.2 Overview illustration

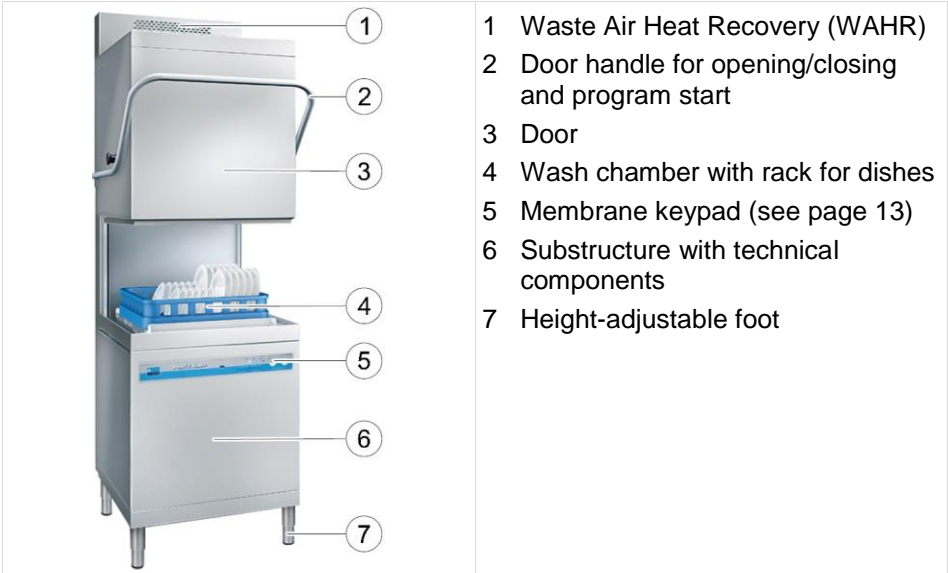

4.3 Membrane keypad

The membrane keypad has 5 keys and 4 control lights. The display reports the current temperatures of the wash and rinse water and displays information messages and error codes where applicable. The control lights at the keys indicate readiness for operation, the active wash program, and a running wash cycle.

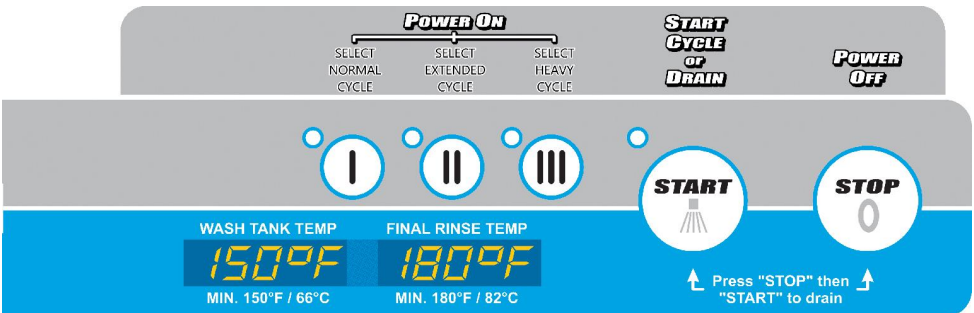

Key



START key with control light

- Starts the program
- Control light on: wash program is running
- Control light flashing: self-cleaning program / drain program is running



STOP key

- Program stops
- Switch-off / prepares self-cleaning feature



Program keys 1–3 with control lights



- Any key switches the dishwasher on
- Program selection
- Control light 1, 2 or 3 on: dishwasher ready for operation / wash program 1, 2 or 3 selected
- Control light 1, 2 or 3 flashing: dishwasher is being made ready for operation

Display

| Display | Meaning |
|---|---|
|  | Current wash temperature Current final rinse temperature |

4.4 Wash programs

DV 80.2

| Program | Meaning | Washware |
|---|-----------|---|
|  | Short | Lightly soiled washware |
|  | Standard | Normally soiled washware |
|  | Intensive | Heavily soiled washware pots, containers, kitchen utensils |

Program assignment



| No. | Setpoint for boiler temperature | | Setpoint for wash cycle time | |
|-----|---------------------------------|------|------------------------------|-------|
| | | | Washing | Total |
| | [°F] | [°C] | [s] | [s] |
| 1 | 185 | 85 | 41 | 66 |
| 2 | 185 | 85 | 65 | 90 |
| 3 | 185 | 85 | 185 | 210 |

NOTE

The concentration of the rinse aid in the water remains constant: if the rinse time is changed, the dosing amount of the rinse aid changes correspondingly.

4.5 Rating plate

The rating plate is on the inside of the front panel and on the right side panel. The rating plate includes the following information:

| | | | |
|--|---|--|-----------|
|  | | MEIKO ① Maschinenbau GmbH & Co. KG D-77652 Offenburg 800-868-3840 | |
| MODEL | ② | INCOMING WATER TEMP | ⑧ °F ⑨ °C |
| SERIAL NUMBER | ③ | NOTE: "AUTO-SAFE" FEATURE AUTOMATICALLY ADJUSTS TIME CYCLE FOR LOWER INCOMING WATER TEMPERATURES | |
| VOLTS | ④ | MINIMUM WASH TANK TEMP | ⑩ °F ⑪ °C |
| HZ | ⑤ | MINIMUM FINAL RINSE TEMP | ⑫ °F ⑬ °C |
| PH | ⑥ | MINIMUM CYCLE TIME (SECONDS): | |
| AMPS | ⑦ | WASH | ⑭ |
|  | | RINSE | ⑮ |
| Intertek 3082672 ETL LISTED CONFORMS TO ANSI/UL 921 CERTIFIED TO CSA 22.2 No. 168 MADE IN GERMANY | | DWELL/DRAIN | ⑯ |
| | | TOTAL CYCLE | ⑰ |

*****CAUTION*****
THIS UNIT MUST BE CONNECTED TO THE FOLLOWING POWER SYSTEM:

⑱

THIS POWER SYSTEM REQUIRES L1, L2 AND L3 (3 PHASE ONLY) BE CONNECTED AND MACHINE GROUND (GND) MINIMUM SUPPLY CIRCUIT CONDUCTOR AMPACITY

⑲

MAXIMUM PROTECTIVE DEVICE AMPACITY : FIXED TRIP CIRCUIT BREAKER

⑳

*****CAUTION*****
FOR SUPPLY CONNECTIONS, USE WIRES RATED FOR AT LEAST 90°C (194°F) USE COPPER CONDUCTOR ONLY

| | |
|--|--|
| 1 Name and address of manufacturer | 2 Model name |
| 3 Serial number | 4 Voltage |
| 5 Frequency | 6 Number of phases |
| 7 Rated current | 8 Incoming water temperature (°F) |
| 9 Incoming water temperature (°C) | 10 Min. water temperature in wash tank (°F)* |
| 11 Min. water temperature in wash tank (°C)* | 12 Min. water temperature for final rinse (°F) |
| 13 Min. water temperature for final rinse (°C) | 14 Min. duration of wash cycle |
| 15 Min. duration of rinse cycle | 16 Duration of drain cycle |
| 17 Duration of total cycle | 18 Power system |
| 19 Min. conductor ampacity | 20 Max. protective device ampacity |

* The water temperature in the wash tank is equal to the rinse temperature.

4.6 Detergent and rinse aid



WARNING – Risk of injury from contact with chemicals

- Observe the safety data sheets and dosing recommendations of the chemical manufacturers.
- Use safety eyewear.
- Wear protective gloves.
- Do not mix different chemical products.



CAUTION

- Only use products that are suitable and approved for commercial dishwashers.
- Do not mix different detergents.

By default, the dishwasher is provided with dosing units for dosing liquid detergent/rinse aid. Manual dosing with powder cleaner is not intended.

4.6.1 Detergent

Detergents are alkaline (pH value should be >7) and are needed to dissolve soiling from the washware. If necessary, the concentration can be adjusted depending on the water quality, washware and degree of soiling. This setting is made during commissioning by an authorized MEIKO service technician or the chemicals supplier. The typical concentration is 0.256 oz/gallon (2 ml/l).

4.6.2 Rinse aid

Rinse aids are acidic (pH value should be between 2 and 7) and accelerate drying of the washware by reducing the surface tension of the water so that it can run off the washware quickly.

Dosing depends on the local water quality and is correct when the water drips evenly from the washware. This setting is made during commissioning by an authorized MEIKO service technician or the chemicals supplier. The typical concentration is 0.0256 oz/gallon (0.2 ml/l).

4.6.3 Checking the correct dosing settings

To check if the normal settings are correct for your chemicals, run three empty wash cycles without a rack to completely cycle the water system and obtain accurate test results. This will only take a few minutes. Then, run a sample load with soiled dishes and examine the results.

- If the detergent setting is too low, the dishes will not be adequately cleaned. In some cases, this can be corrected by simply selecting a longer program time (using the cycle selection II (Extended) or cycle selection III (Heavy) keys). However, the detergent concentration may also need to be adjusted.
- Low rinse aid settings may cause spotting and streaking on the dishes.
- If too much of one of the two chemicals is added, the additional chemicals will be wasted. Often, this is difficult to recognize unless you determine the period your chemicals supply will last. In case the chemicals are used up quickly, you might need to adjust the concentration of the chemicals.

Any adjustments to the factory-set chemical dosing system may ONLY be performed by an authorized MEIKO service partner. Changes by non-authorized personnel will void the guarantee.

4.6.4 Dosing units

The components of the dosing units are subject to high demands and must therefore be regularly maintained and, if necessary, replaced in accordance with the maintenance specification.

The service life of the dosing units and other dishwasher components depends on the use of suitable chemicals.

4.6.5 Change of products



CAUTION

When changing the detergent product (even to a product from the same manufacturer), crystallization may occur, which can lead to failure of the dosing system.

- When changing the detergent product, flush the dosing system using warm water.

Procedure for changing the detergent product:

1. Provide a suitable container with warm water and insert the suction lance.

2. Thoroughly flush the dosing system several times by **venting (priming) the lines**, see page 42.
3. Wipe the suction lance and put it into the canister with the other detergent product.
4. Refill the dosing system by **venting (priming) the lines**.

4.7 Additional equipment

Auto Safe

An internal boiler heating is regulated by the electronic control system to ensure a proper final rinse temperature, regardless of the fresh water temperature.

Soft Start

The wash water is pumped at a reduced pressure for the first few seconds of the wash cycle. This protects the washware from being damaged by a sudden burst of pressure.

Pressure booster pump

A pressure booster pump ensures that the final rinse pressure remains constant.

Drain pump

For wall drains or floor drains.

Aqua Stop

Automatically shuts the machine down if a water leak is detected.

5 Technical data

MEIKO has created a data sheet that shows machine dimensions as well as connection and consumption values.

For additional data, please refer to the data sheet.

Transport weight (including packaging)

| Version | Weight, approx. |
|---------|--------------------|
| DV 80.2 | 334 lbs (151.5 kg) |

Noise emission

Workplace noise level $L_{pA} \leq 70$ dB(A).

6 Transport



IMPORTANT

During shipping and installation, the dishwasher must be positioned upright or on its left side. Some water may remain in the lines after pre-shipment testing. If the unit is positioned in any manner **except** upright or on its left side, this water can affect the operation of the water level sensor.

- Check that the delivery is complete immediately upon receipt by comparing it with MEIKO's order confirmation and/or the delivery note.
- If applicable, submit claims for any missing parts immediately to the freight forwarder and notify MEIKO.
- Check the machine for shipping damage.

NOTE

If you suspect any shipping damage, the shipping company and MEIKO (Customer Service (800) 868-3840) must be informed immediately in writing. Photograph any damaged parts and send the pictures to MEIKO.



WARNING – Danger of injury due to machine tipping

- Only qualified personnel may carry out transport works.
- Please observe the safety information on the packaging.
- Always transport the machine on a wooden frame only.
- Wear protective gloves and safety shoes.

The packaging is specifically designed to allow the machine to be moved safely and securely using a pallet jack. For safe transport, the dishwasher is supported by a special square timber frame.

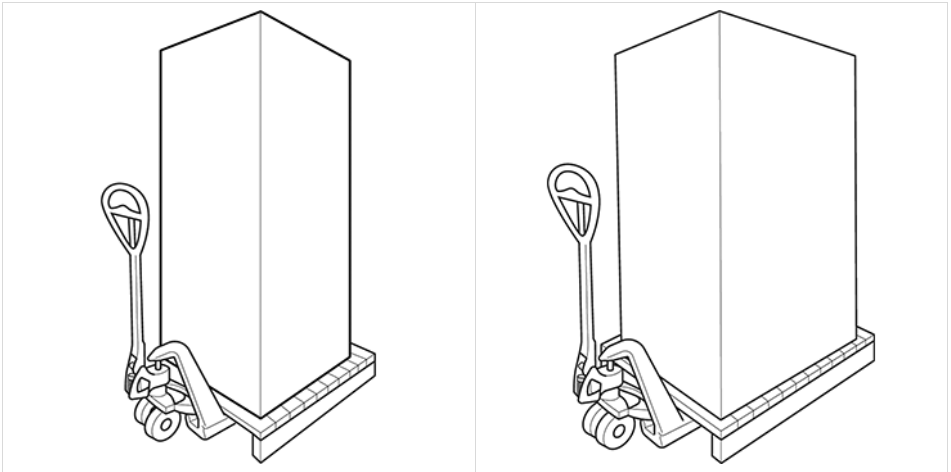

- Transport with care.
- Observe the instructions for safe transport on the packaging.
- Open the packaging using a suitable tool.
- Unpack the dishwasher only once transport is completed.

7 Requirements for installation

7.1 Requirements for the installation location

- The area **MUST** be frost-free. Freezing temperatures (32°F/0°C or lower) inhibit proper operation and can damage internal components.
- The area **MUST** have a firm floor surface. It is possible to compensate for uneven flooring by adjusting the feet.
- The area should be away from appliances, furniture or surfaces that can be damaged by steam. If this is not possible, these items should be protected from the small quantities of steam that are released during normal operation of the dishwasher.

7.2 Requirements for the wastewater connection

A wastewater pipe is integrated into the drain pump.

- Connect the drain hose to the on-site wastewater pipe.
- Observe the minimum height for the drain of 24" (610 mm).
- Minimum diameter of the drain: 1 ½" (38 mm).

- Depending on the dishwasher's field of application, a grease trap may be included, based on the general/location-specific regulations.
- Drain Water temperature can be in excess of 150 °F (65 °C). If a local plumbing code requires a lower drain temperature, please refer to optional Drain Water Tempering kit.

7.3 Requirements for the fresh water connection

Fresh water connections and their components must be made in accordance with local regulations. From a biological perspective, the fresh water must be of drinking water quality. This also applies to treated water.

Installation components and materials must be suitable and permitted in accordance with local regulations. A solenoid valve is integrated into the dishwasher's fresh water pipe. This, together with the leakage detector in the base drip tray in the subframe, ensures that the fresh water supply is shut off in the event of a leak in the machine.

Recommended water hardness:

- 1–3 grains per U.S. gallon (gpg) (6 gpg, maximum)

Recommended water temperature:

- 140°F (60°C)
Colder water will result in a longer preheat time during startup and will extend the wash cycle time. The required temperatures will still be reached.

Pressure range of the fresh water supply flow pressure upstream of the solenoid valve:

- 8.7–72.5 psi (0.6–5 bar)

Measures to ensure correct water pressure:

- If the minimum flow pressure is too low, increase the pressure using a pressure booster pump (not supplied as standard).
- If the maximum pressure is exceeded, limit the pressure using a pressure regulator (not supplied as standard).

Other measures:

- Make sure that no foreign iron particles can enter the machine via the fresh water connection. The same also applies to contamination by other metal particles (e.g. copper shavings).
- A dirt trap must be fitted in the fresh water supply to protect the solenoid valve. An additional dirt trap is not required.

- The feed hose must be sufficiently long so that the machine can be moved for servicing purposes.

7.4 Requirements for the electrical connection



IMPORTANT

The wiring diagram is under the upper cover of the dishwasher. It must remain in the dishwasher. The rating plate with the electrical connected values is on the inside of the front panel and on the outside on the right side panel.

Requirements for the operating company:

- The correct voltage and current type must be available.
- Safeguard the power supply in accordance with the regulations and provide it with an all-pole main switch in the permanently installed electrical installation.
- Connect the dishwasher to an equipotential bonding system.
- Do not connect any additional consumers to the fuse protecting the dishwasher.
- Electricity supply without a neutral conductor (N): When connecting to three-phase current, use a 4-pole terminal strip (L1, L2, L3, PE) or a 3-pole terminal strip (L1, L2, PE).

The products are intended for permanent connection to the locally available power supply and have been tested for the market accordingly. Any other type of electrical connection must be made by specially trained personnel.

Install the dishwasher in accordance with local regulations. In the absence of any such regulations, install the machine in accordance with the applicable requirements in the National Electrical Code, NFPA 70, Canadian Electrical Code (CEC), Part 1, CSA C22.1 and the Standard for Ventilation Control and Fire Protection of Commercial Cooking Operations, NFPA 96.

8 Installation

▶ IMPORTANT

During shipping and installation, the dishwasher must be positioned upright or on its left side. Some water may remain in the lines after pre-shipment testing. If the unit is positioned in any manner **except** upright or on its left side, this water can affect the operation of the water level sensor.

▶ IMPORTANT

Installation may be performed only by an authorized service technician.

8.1 Accessing the utility connections

In order to attach the dishwasher supply connections, the front panel must be removed.

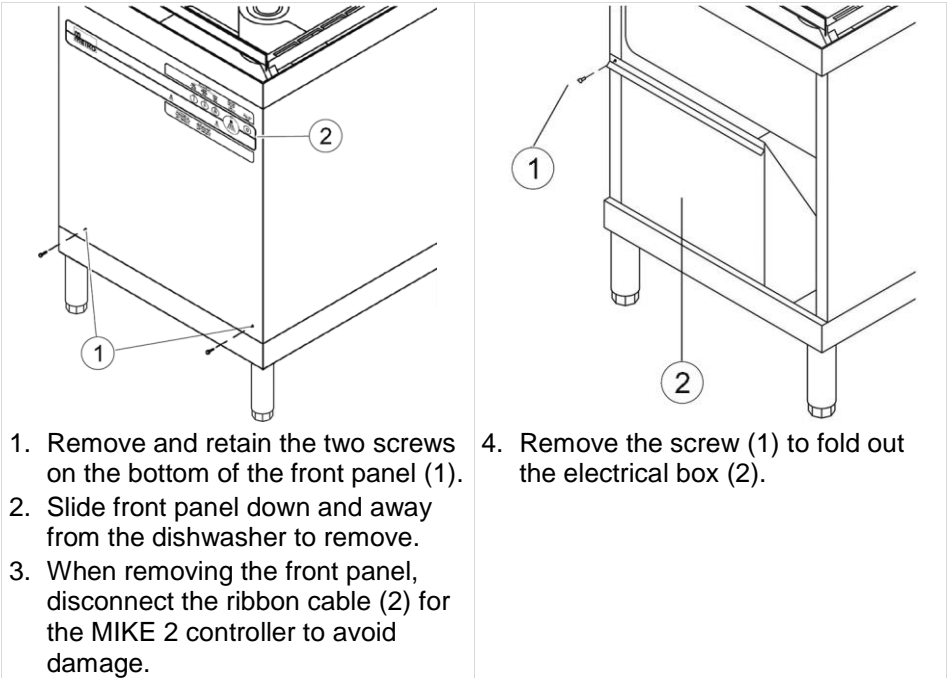

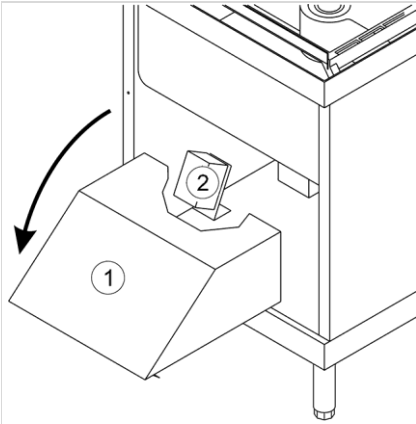

Fold out the electrical box and connect the terminal block for the main electrical supply (1) and the terminal block for the chemical dispenser (2, if used).

After connection, perform all steps in reverse order.

8.2 Electrical installation



WARNING – Danger to life from electric shock

- Work on the electrical system must only be conducted by qualified personnel who comply with the electrotechnical rules.
- Disconnect the machine from the power supply before removing any casing parts or working on the electrical system. To do this, turn the local main switch to **OFF** and ensure that it cannot be switched back on again.
- Attach all housing parts again before switching on the voltage again.

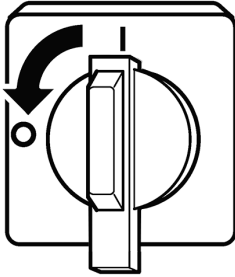

1. To do this, turn the local main switch to OFF and ensure that it cannot be switched back on again.
2. Check whether the supply lines are sufficiently dimensioned for the machine's current consumption. The amperage and minimum supply line requirements are indicated on the rating plate and on the electrical data label.

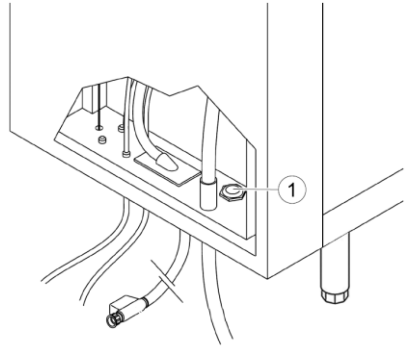

3. Route the electrical supply line through the strain relief (1) and to the electrical box.
4. Check that the electrical supply line is long enough to allow the machine to be repositioned for subsequent maintenance.
5. Fasten the supply line using the strain relief (1). You should leave enough slack in the supply line to prevent stress on the connections.

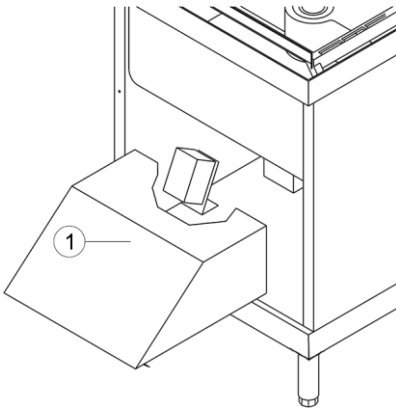

6. The main terminals (1) are located in the electrical box.

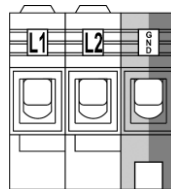

**208-230 V, 60 Hz,
1 Phase**

L1 und L2 = „hot“
(line)
yel/grn = ground

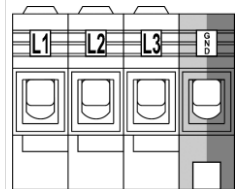

**208-230 V, 60 Hz,
3 Phase or
460 V, 60 Hz
3 Phase**

L1, L2, L3 = „hot“
(line)
yel/grn = ground

7. Connect the supply line in accordance with the figure and the wiring diagram.

Line voltage for Exhaust fan (Option)

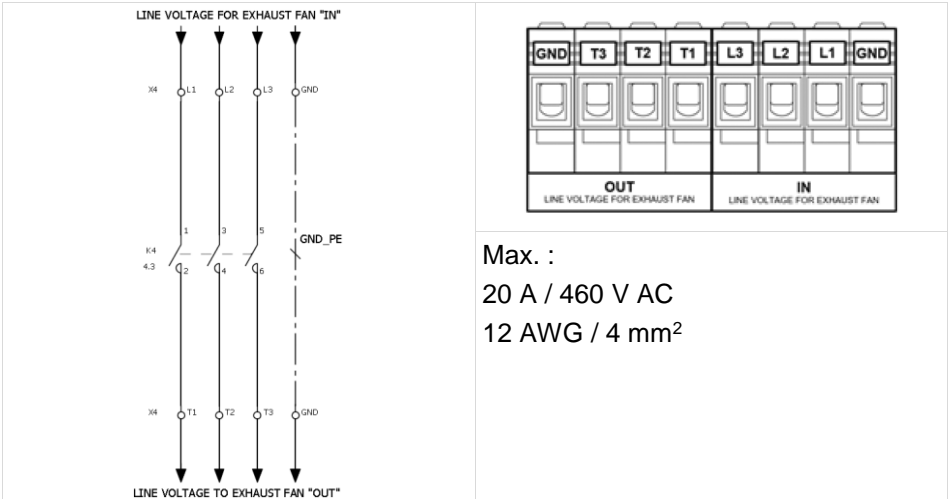

Max. :
20 A / 460 V AC
12 AWG / 4 mm²

Terminal:

- Screw torque: 0.8...1.0 NM
- Solid/fine-stranded conductor 0.5...6 mm² / 22...8 AWG
- Strip length 12 mm / 0.47 inch
- To connect the wires to the terminals for the on-site ventilation system, the front panel must be removed.

Strain relief:

- Clamping range of the strain relief from 11–21 mm / 0.43–0.83 inch: minimum outer diameter of the connection line 11 mm / 0.43 inch, maximum outer diameter of the connecting line 21 mm / 0.83 inch
- The strain relief must be tightened to withstand a direct pulling force of 156 NM / 35 lb (156 N) applied for 1 minute, without any displacement, in accordance with UL 921

Supply connection:

- Flexible cords and cables shall comply with CSA C22.2 No. 49 and UL 62 and shall be Type S, SE, SO, SOO, ST, STO, or STOO
- The on-site ventilation system must be connected to the equipotential bonding. All power supply connections must be made in accordance with „UL Standard for Safety for Commercial Dishwashers, UL 921, Eighth Edition, Dated January 30, 2020“ section „4.7 Powersupply connections“.

Protective equipotential bonding

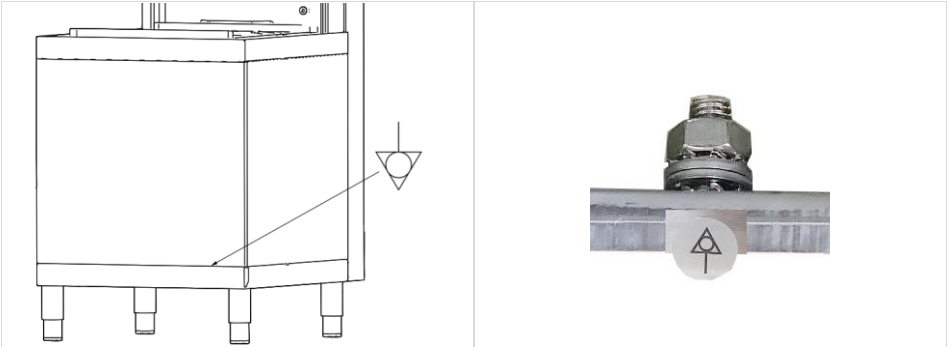

The screw for the equipotential bonding is located on the front of the machine behind the front panel.

8.3 Connecting the fresh water pipe

NOTE

Damage to property due to deposits

Deposits in the fresh water supply (tube sealant, metal particles, soldering agent etc.) can result in damage to the dishwasher.

- Prior to connection, thoroughly flush the fresh water pipe using fresh water.



IMPORTANT

The fresh water pipe must be sufficiently long so that the dishwasher can be moved for servicing purposes.



IMPORTANT

When installing a machine with WAHR, it is mandatory to connect the machine to the cold water pipe.

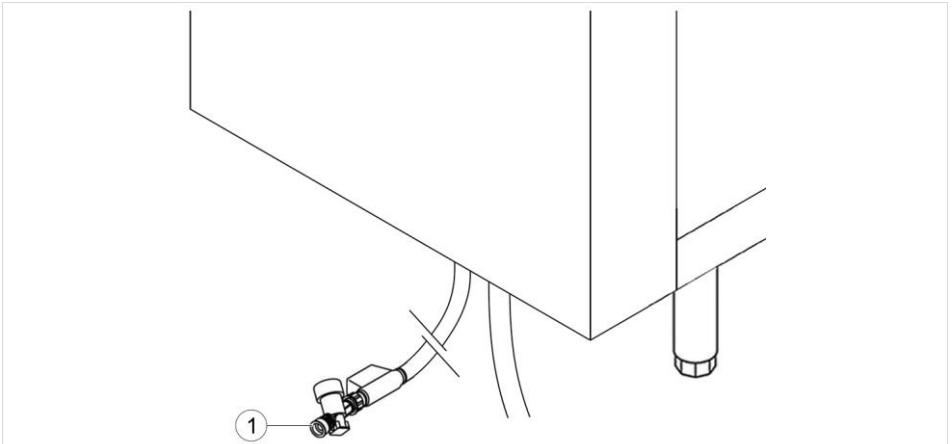

1. Connect the dishwasher fresh water connection (1, in the scope of delivery) to the fresh water supply.
2. Check the water pressure, water temperature and water hardness to see if the values are in the correct range, see page 22.

8.4 Connecting the wastewater pipe

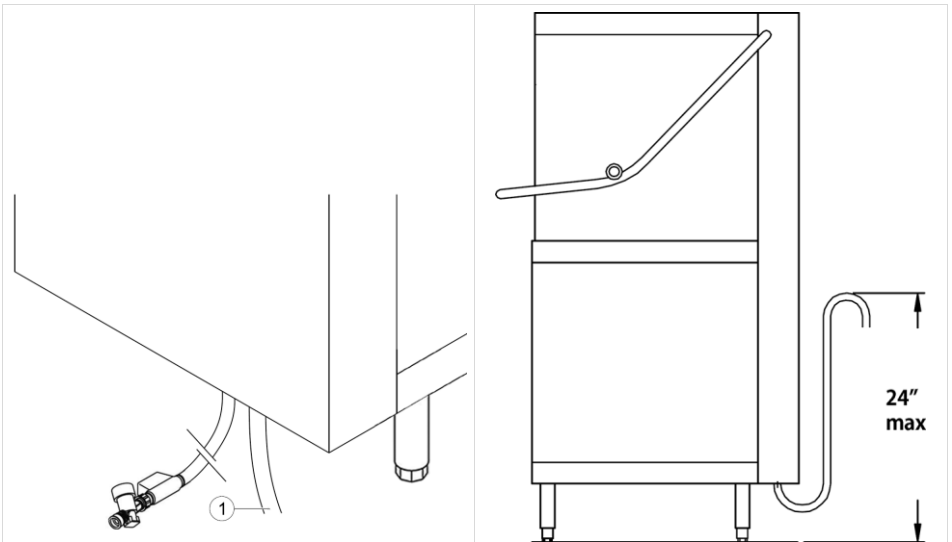

1. Route and connect the wastewater hose (1) of the dishwasher to the drain. The drain height must not be higher than 24" (610 mm).

2. Install a grease trap (not supplied as standard) in the wastewater pipe if this is required by the local regulations.
3. If local regulations require a lower wastewater temperature than 150°F (65°C), install the wastewater temperature conditioning kit, see page 21.

8.5 Connection for wastewater temperature control (optional)

The wastewater can have a temperature of more than 150 °F (65 °C). Install a temperature conditioning kit if a lower wastewater temperature is required by local regulations.

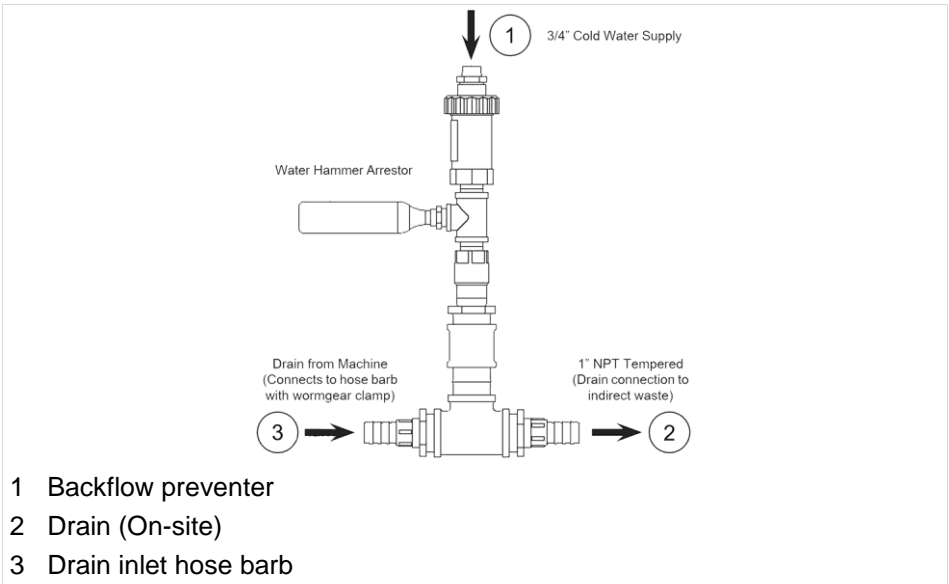

Connection procedure:

1. Position tempering assembly, as required, behind the machine..
2. Connect **cold water supply line** to the backflow preventer (1), using a 1/2" pipe fitting. If you are soldering, be sure to remove the union on the backflow preventer. This will insure that the plastic internal parts do not melt.
3. Connect from drain (2) of the tempering assembly to an indirect waste drain pipe. If required, the 1" barb can be removed and the drain can be connected using 1" fittings and pipe.
4. Connect drain hose from the machine to the drain inlet hose barb (3) and secure with wormgear clamp.

5. Turn on **cold water** and check for leaks.
6. Fill machine and operate. The drain water exiting the drain water tempering assembly (2) should be no higher than 140 °F (60 °C).

8.6 Install waste air heat recovery (WAHR option)

8.6.1 Parts supplied for installation

| Part | Quantity | Part | Quantity |
|--------------------------------------|----------|---------------------------|----------|
| 1. Bolt (M5 x 12) | 6 | 2. Washer (M5) | 10 |
| 3. Nut (M5 self-locking with flange) | 6 | 4. Nut (M5, self-locking) | 4 |
| 5. Cable ties (200 mm) | 10 | 6. Self-tapping screws | 11 |
| 7. Metal clip | 8 | | |

8.6.2 Installation



IMPORTANT

Before installing the WAHR unit, make sure that the machine is **not** connected to the power supply!



1. Ensure that the machine is properly adjusted.

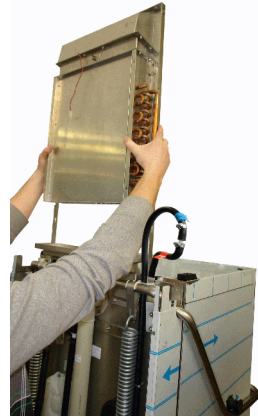

2. Unpack the heat exchanger and place it on the machine as shown.

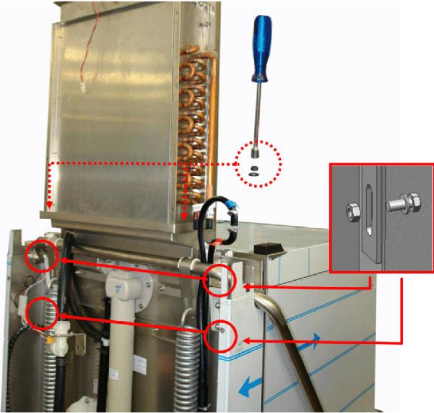

3. Align the heat exchanger and mount it with the supplied fixing material (top: 2x M5 bolt + M5 self-locking nut, bottom: 4x M5 washer + M5 self-locking nut with flange).

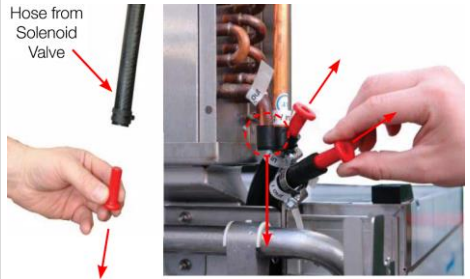

4. Remove and discard the 5 hose plugs.

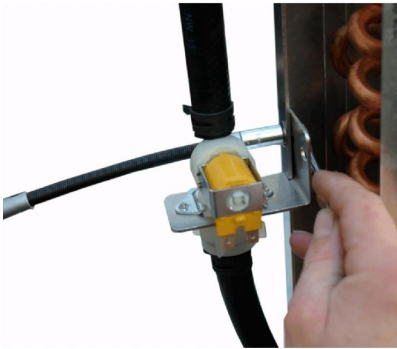

5. Secure the solenoid valve to the back of the heat exchanger with 1x M5 bolt, 1x M5 self-locking nut and 1x M5 washer. Screw the angled holder into the Twistlock.



6. Connect the hose to the 90° elbow and secure it with the supplied spring clamp.



7. Connect the hoses to the heat exchanger as marked and secure with hose clamps. When mounting the hoses, make sure that the connection pipes are not damaged (kinked).



8. Make sure that the hoses are routed behind the supplied protective bracket so that they do not become trapped in the door mechanism.

CAUTION – Do not kink or crush the hoses when connecting them, otherwise the machine cannot be filled properly.



9. Secure the connection cable with the cable ties supplied.



10. Connect the solenoid valve.

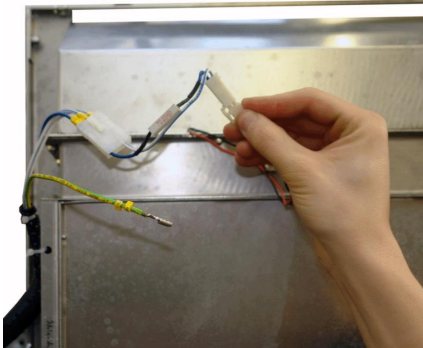

11. Connect the Molex connectors for the fan.

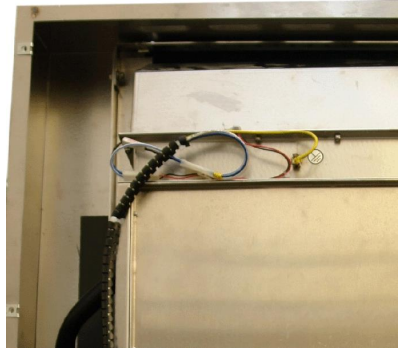

12. Connect the earth cable.
Lay/fasten the cable properly in the rear channel.

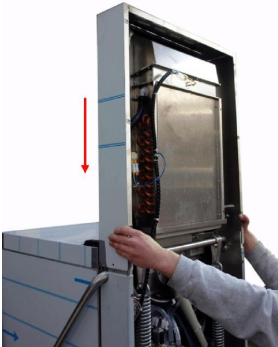

13. Fit the hood/cover for the heat exchanger.

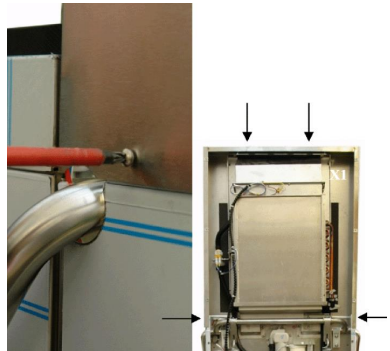

14. Secure the hood/cover for the heat exchanger with 4 self-tapping screws.



15. Screw on the cross member with 1x M5 bolt, 1x M5 self-locking nut and 1x M5 washer.



16. Option: For machines with a rear panel, place the metal clips (6x) over the remaining holes.



17. Fasten the rear panel of the heat exchanger using 6x self-tapping screws. **Then** fasten the lower rear panel of the machine.



18. Completely installed waste air heat recovery system.



IMPORTANT

Always connect the machine to cold water (maximum 80°F/27°C) for the heat recovery to work properly.

Black electrical connection

E The strain relief is located at the bottom rear of the machine. The wiring should be loose enough to allow the machine to be moved for maintenance.

Fresh water connection

W The connection for the garden hose with internal thread (3/4") is present. When using the supplied external Y strainer, the female garden hose adapter can be removed to provide a 1/2" NPT male or 3/4" NPT female connection as needed. The supplied hose has a length of 4'7" (2616 mm).

Connection to the drain

D Requires an indirect connection to a 1-1/2" (38 mm) drain pipe (wall or floor). The supplied hose is 4'7" (2616 mm) long and should be cut to the appropriate length at the time of installation so that the machine can be repositioned for maintenance.

8.7 Connecting the dosing system

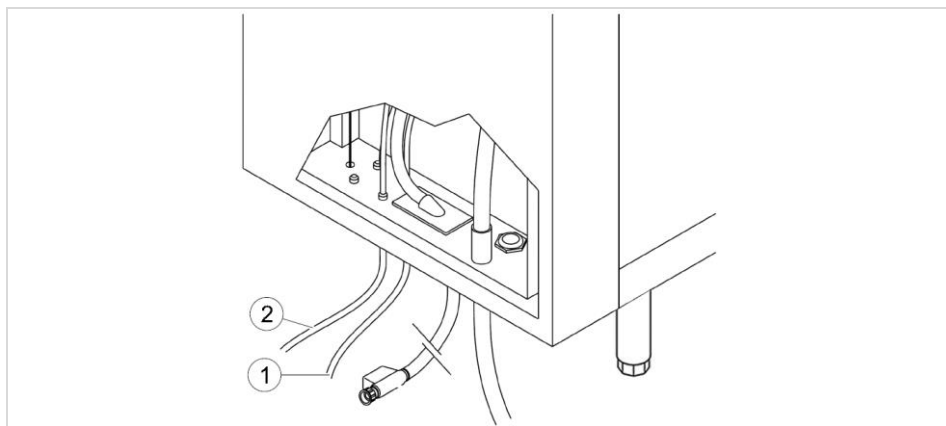

1 Detergent pipe (transparent)

2 Rinse pipe (blue)

The DV 80.2/80.2 WAHR is designed for use with liquid detergent and liquid rinse aid. All versions are equipped with internal dosing units for liquid detergent and rinse aid and two feed hoses (1, 2) exiting from the lower rear of the machine. These hoses can be easily connected to the canisters for detergent and rinse aid.



NOTE

If you wish to use an external chemical dosing system, please contact the MEIKO plant for additional instructions and requirements.

8.8 Connecting the detergent and rinse aid canisters



WARNING – Risk of injury from contact with chemicals

- Observe the safety data sheets and dosing recommendations of the chemical manufacturers.
- Use safety eyewear.
- Wear protective gloves.
- Do not mix different chemical products.

1. Ensure that the rinse aid/detergent is compatible with the machine. In particular, use a commercial, low-foaming detergent suitable for commercial dishwashers.
2. Check that the canisters/dispensers are correctly installed according to the manufacturer's instructions.

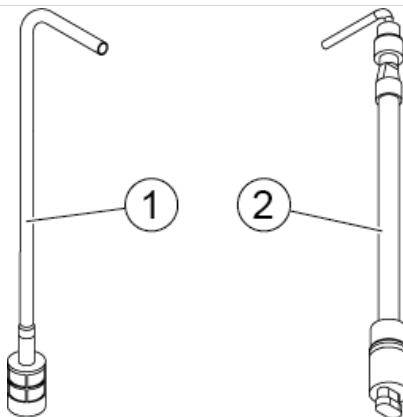

3. Insert the rinse aid suction lance (1) and the detergent suction lance (2) in the corresponding canister.
4. Slide the rinse aid hose (blue) and the detergent hose (transparent) onto the associated suction lance hoses. The suction lances must be inserted so that they are completely at the bottom.
5. Clamp the two hoses using a collar clamp.

8.9 Tabling attachment

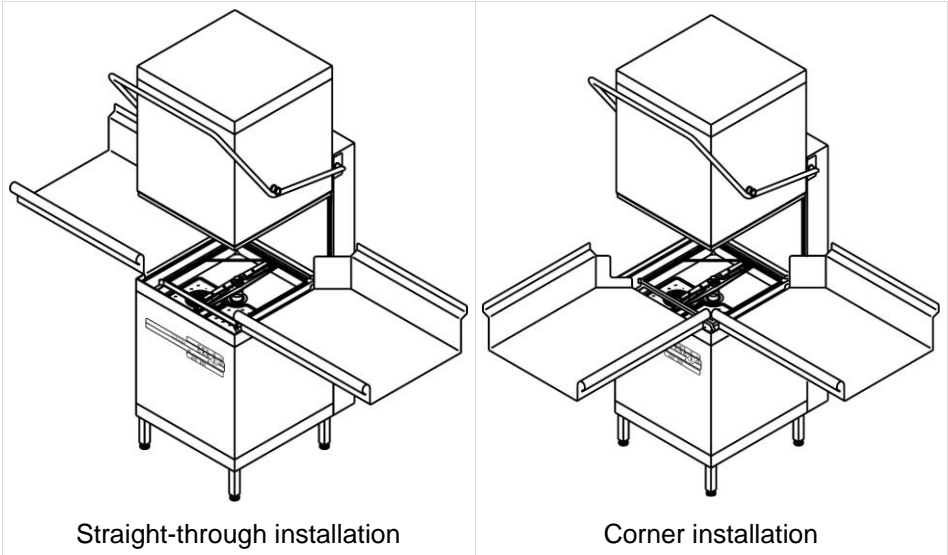

If the machine is to be placed in a corner, perform the following steps before attaching the tables:

1. Set up the machine so that the **left rear side** of the machine faces the corner of the wall, as shown in the figure above. For corner installations, this placement is necessary to ensure that the operator can access the control panel.

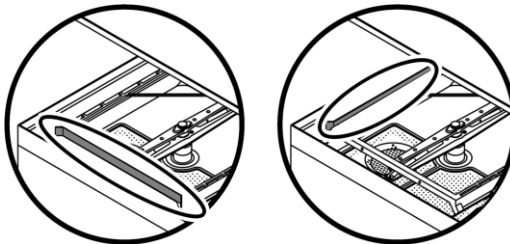

2. Remove the front rack guide. The guide is held by two nuts. Replace the guide on the **left** side in the two mounting holes provided.

Position the machine and the tables:

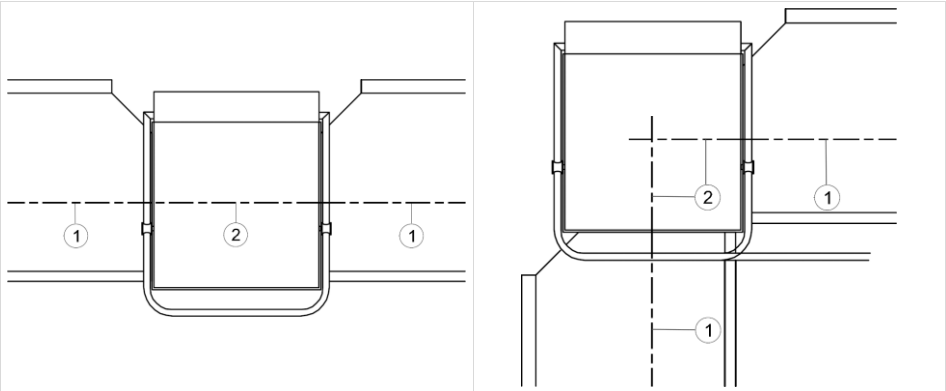

3. Ensure that the centerline of the opening at the end of each table (1) is aligned with the centerline of the rack holder of the machine (2).
4. Ensure that the height of the table surface matches the height of the machine shelf rail to ensure a smooth transition. The standard height of the table surface is 34" (864 mm).
5. Check that the machine is level.

NOTE

The height of the machine and most tables can be adjusted by turning the feet at the ends of the legs.



CAUTION

- After adjusting the height of the machine, always check that it is level to ensure proper operation.

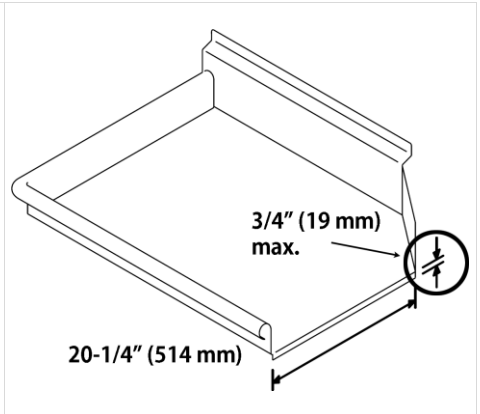
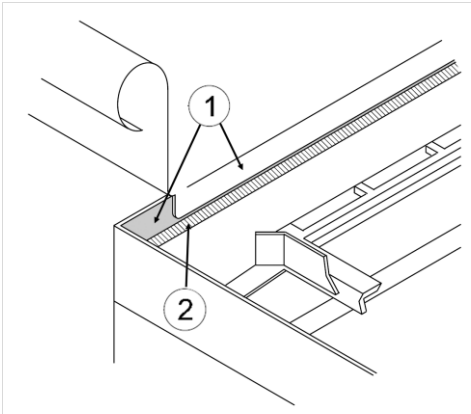

- Position each table lip on the machine. Make sure that the insertion lip is in contact with the inner, vertical mounting surface (2). If the table insertion lip extends beyond the vertical mounting surface and up to the slanted inside of the machine (2), it is not fitted properly. The table insertion lip should be no more than 3/4" (19 mm) deep to ensure proper installation on the machine.

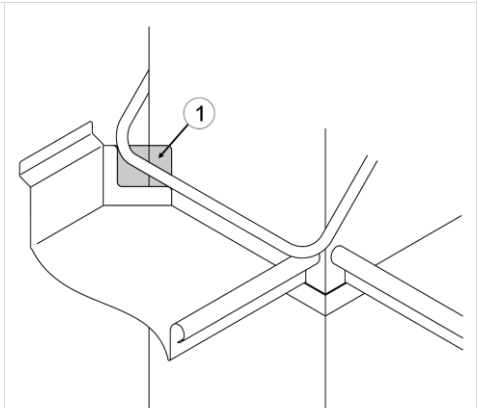
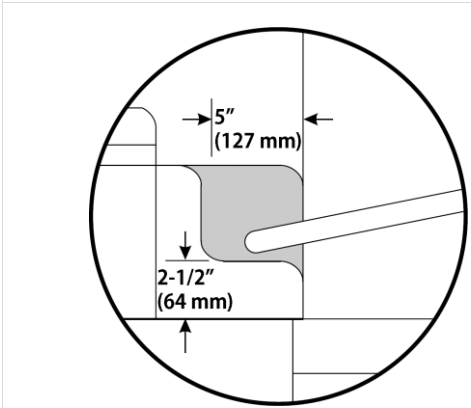

- For corner installations, check that the sides of the front table do not prevent the door handle from being pushed down far enough to operate the door switch. Slowly push down on the handle, there should be an audible "click" when the switch engages.
- If necessary, cut the table sides (1) to clear the handle and allow the switch to engage.
- After the tables have been correctly positioned, secure them to the machine with silicone sealant.

8.10 Terminating the installation

1. Check and tighten all screws of the electrical connections.
2. Reattach all housing parts to the machine.
3. Set the circuit breaker/fuse disconnect switch to ON.
4. Vent the detergent and rinse aid dosing units, see page 42.

For disposal of packaging materials, see page 67!

9 Commissioning



WARNING – Danger of injury when entering a danger zone

- Only qualified personnel may work on the machine.
- Remove unauthorized persons from the danger zone.
- Block off the danger zone and mark it for third parties.
- Always wear cut-resistant protective gloves when removing casing parts or working inside the machine.

9.1 Checking the requirements for commissioning

NOTE

Damage to property due to steam emission

Small quantities of steam may escape from the dishwasher. It is possible that adjacent furniture swells.

- Protect adjacent furniture from swelling.
- If possible, avoid installing the machine in an area close to furniture susceptible to swelling.

Requirements to be provided by the customer:

- Consistently frost-free storage and installation area.
- Anti-slip floor coverings provided in the work area around the machine.
- All connections are made correctly as described above.

9.2 Performing commissioning

To avoid damage or injuries during machine commissioning, please note the following points:

- Check supplier parts (e.g. external water handling devices). More detailed information can be found in the relevant operating instructions.
- Ensure that all tools and foreign parts are removed from the machine.
- Check if all casing parts are mounted on the machine.
- Turn on the main switch.
- Vent the pipes for the chemicals and check for correct dosing.











9.3 Venting (priming) the pipes





Venting of the detergent or rinse pipes must be performed during commissioning to fill the pipes with detergent and rinse aid.

The pipes must also be vented if the dosing units have sucked in air. This occurs if a canister is completely emptied during operation, or if one of the suction lances was not inserted all the way to the bottom of the canister.

For machines with external dosing systems, the detergent and rinse pipes must be vented in accordance with the manufacturer instructions.

For machines with built-in dosing systems, vent the pipes as follows:

| | |
|---|---|
|   | <p>1. Press the STOP key for approx. 5 seconds until CodE 1- - - - is displayed.</p> |
|   | <p>2. Press the START key 5 times until 1-1 - - - - is displayed.</p> |
|   | <p>3. Press the program key I. 1-2 - - - - is displayed.</p> |
|   | <p>4. Press the START key. Priming of the rinse pipe will start. The time remaining is displayed. By default, priming takes 180 seconds.</p> |
|   | <p>5. If the time has expired and 1-2 - - - - is displayed, press program key I. 1-3 - - - - is displayed.</p> |

| | |
|---|---|
|   | <p>6. Press the START key. Priming of the detergent pipe will start. The time remaining is displayed. By default, priming takes 30 seconds.</p> |
|   | <p>7. If the time has expired and 1-3 ---- is displayed, press the STOP key to switch the machine off.</p> |

10 Operation/use

10.1 Prior to switching on the machine



WARNING – Risk of injury from contact with chemicals

- Observe the safety data sheets and dosing recommendations of the chemical manufacturers.
- Use safety eyewear.
- Wear protective gloves.
- Do not mix different chemical products.

The dishwasher may only be used if the operating instructions have been read and understood. Incorrect operation may result in personal injury or damage to property.

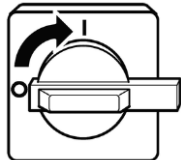
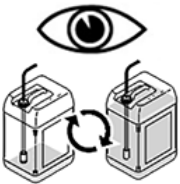
| | |
|---|---|
|  <p>1. Ensure the water supply is available.</p> |  <p>2. Turn on the main switch.</p> |
|  | <p>3. Check the detergent and rinse aid and replace in accordance with the manufacturer instructions, if necessary.</p> |

NOTE

If there is air in the hoses, the dosing function will not work properly. The hoses must be vented, see page 42.

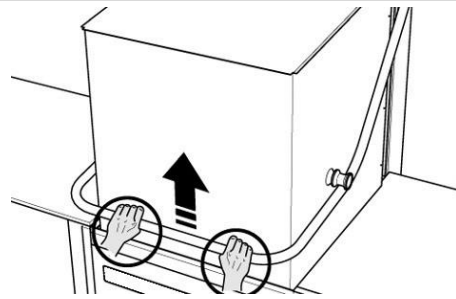

4. Open the door.

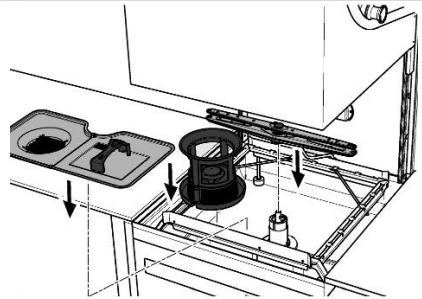

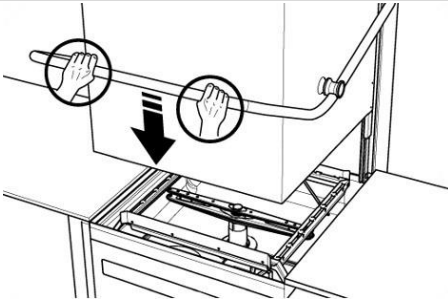

5. Insert the filter, the tank cover sieve and the wash systems.



6. Close the door.

10.1.1 Starting up the dishwasher

The time required for the machine to be ready to operate depends on the temperature of the supplied water and the capacity of the installed boiler or tank heating.

| | |
|---|---|
|  <p>The dishwasher is closed and does not have a rack inside.</p> <ol style="list-style-type: none">1. Press wash program keys 1, 2 or 3. |  <p>The dishwasher will be filled and heated up. During this time, the control light above the selected program key flashes.</p> |
|  <p>When the machine is ready to operate, the control light above the selected program key is permanently on.</p> | |

10.2 Washing

10.2.1 Useful information for loading the washware

- ▶ • Remove gross leftovers.
- Pour leftover drinks into the sink.
- Soak cutlery until it will be washed.
- Do not polish glasses, cutlery and dishes as even clean and fresh towels may not be germ-free.



- Always load hollow containers upside down. Otherwise, the water will not be drained from the washware and brilliant drying will not be possible.
- Keep a space between the hollow containers so that they do not rub against each other. This prevents scratches.
- Select a rack with appropriate compartment dividers so that the glasses will remain a correct position.



- Place plates, trays, and dishes into the racks at an angle. The inner surfaces face upwards.



- If cutlery quivers are used, always load the cutlery pieces with the handles down.
- Load an assortment of spoons, knives and forks into each cutlery quiver, as identical cutlery often is too closely spaced.
- Do not overload the individual cutlery quivers.



- Do not stack dishes in the rack. Direct contact with the wash water would be more difficult and a longer program duration would need to be selected. It is more efficient to load the rack with fewer items and run shorter wash cycles.

10.2.2 Selecting the wash program



- Press the required program key.



The control light of the selected program key is on.

10.2.3 Starting the wash cycle

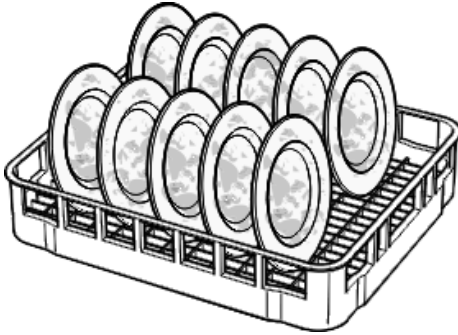

1. Pre-wash the washware (remove any gross food waste, napkins, tooth picks, lemon peel etc.).
2. Put the washware into the rack and pre-clean with the hand sprayer.

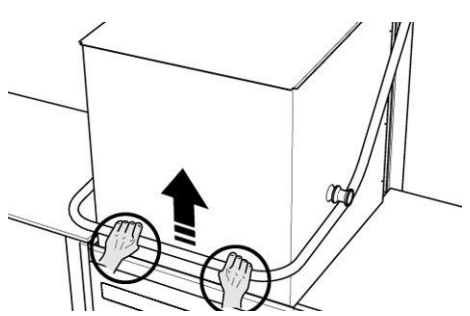

3. Open the door.

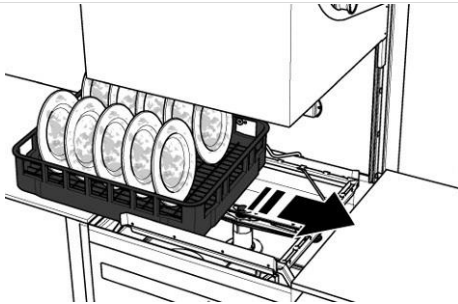

4. Insert the rack into the dishwasher.



5. Change the program, if required, see page 46.

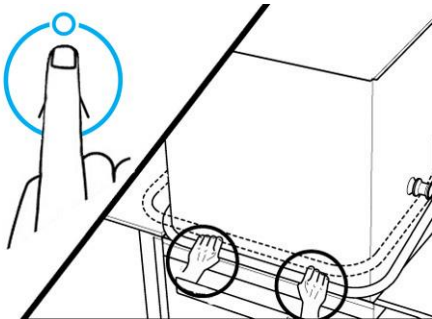

6. Close the door and press the door handle down briefly to start the cycle. Alternatively press the **START** key. The control light is on as long as the program is active.

The dishwasher is equipped with a Soft Start feature, which pumps the water through the arms slowly for the first few seconds of the cycle to protect fragile ware. After a few seconds, full pressure will engage. The time of the total cycle will be at least as long as the times shown on the machine's rating plate. When using a cold water supply, the machine will automatically extend the wash cycle if necessary until the final rinse water can be heated to the minimum of 180 °F.

If the machine is equipped with the optional waste air heat recovery system, a separate heat recovery cycle will follow the final sanitizing rinse.



IMPORTANT

The door should not be opened during the heat recovery cycle, or steam will escape into the room.

10.2.4 Unloading the washware



CAUTION – Danger of burns from hot wash water, hot washware and hot machine parts

- Wear protective gloves, if necessary.
- Let the washware cool down before emptying, if necessary.
- Let the machine cool down before touching machine parts, if necessary.
- Never open the door during a wash cycle.
- Only open and close the door using the designated handle(s).

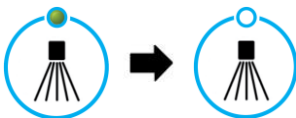

At the end of the program, the control light turns off and an acoustic signal sounds.

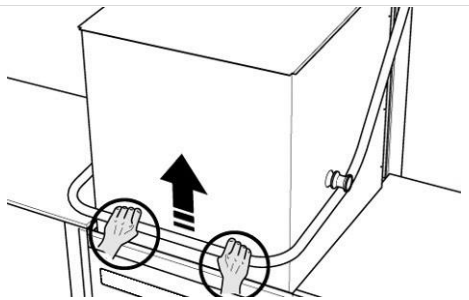

1. Open the door.

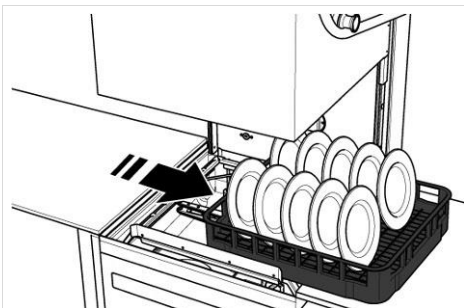

2. Carefully remove the rack.

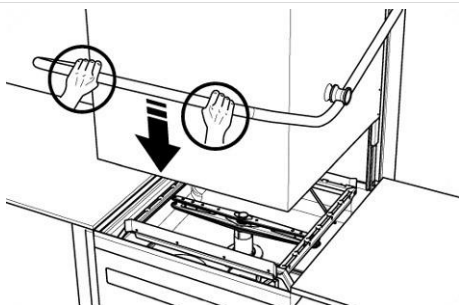

3. Close the door.

10.3 Switching off the machine



WARNING – Danger of scalding

- Do not open the door during self-cleaning.

The dishwasher is closed and does not have a rack inside.



1. Press the **STOP** button.
All control lights turn off.



2. Press the **START** key.



The self-cleaning program starts. The control light near the **START** key flashes. The wash water is pumped out and the wash chamber is sprayed with hot fresh water.

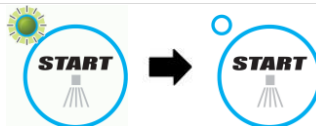

At the end of the program, the control light turns off. Now, the machine can be cleaned, .

10.4 Replacing the canisters



WARNING – Risk of injury from contact with chemicals

- Observe the safety data sheets and dosing recommendations of the chemical manufacturers.
- Use safety eyewear.
- Wear protective gloves.
- Do not mix different chemical products.

10.4.1 Replacing the canisters

INFO

420

Rinse aid empty

INFO

520

Detergent empty



IMPORTANT

The canisters for detergent and rinse aid are located in close proximity to the dishwasher.



IMPORTANT

When using a suction lance that detects whether a canister is empty, shortage of detergent or rinse aid will be indicated on the display.

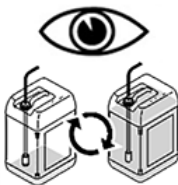

1. Remove the suction lance from the empty canister and insert it into a full canister.

2. If air has been sucked in: vent the pipes, see page 42.

10.5 Malfunctions

Many malfunctions can be rectified without the help of the customer service. The following malfunctions can be remedied by the operating personnel or the in-house technician.

Common malfunctions

| Malfunction | Possible cause | Remedy |
|------------------------------------|---------------------------------|---|
| Dishwasher not filling up | No water available | Open shut-off valve |
| | Dirt trap clogged | Clean dirt trap |
| | Door open | Close door |
| Final rinse not spraying | No water available | Open shut-off valve |
| | Dirt trap clogged | Clean dirt trap |
| Streaks/smears on washware | Inappropriate rinse aid | Change product |
| | Incorrect dosing quantity | Adjust dosing quantity |
| | Water pre-treatment defective | Check water pre-treatment |
| Bubbles and streaks on washware | Overdosing | Have the dosing quantity adjusted |
| Water drops on washware | Underdosing | |
| Strong foam formation in wash tank | Dirt level too high | Pre-wash washware more thoroughly/change tank water more frequently |
| | Hand dishwashing detergent used | Do not use a foaming hand dishwashing detergent for pre-cleaning or for cleaning the machine. Foam can cause malfunctions in the dishwasher and poor washing results. |
| | Inappropriate detergent | Change product |
| | Inappropriate rinse aid | |

Please contact your authorized MEIKO customer service if the listed measures cannot solve the problem.

For a list of authorized customer service points, please either scan the QR code on the back cover of these operating instructions, visit our website at www.meiko.us or give us a call at (800) 868-3840.

10.5.1 Messages



When a malfunction occurs, an information or error message (**INFO/ERR**) is displayed.

- Information messages (**INFO**) can be acknowledged using the START key. If the cause has been remedied (see table), operation can be continued.
- Error messages (**ERR**) usually require the deployment of an authorized service technician.
- If the machine displays an information or error message not listed in the following tables, contact your service technician.

| INFO | Description | Possible cause | Measures/remedy |
|------|-------------------------------------|--|--|
| 120 | Emergency program active | No boiler/tank heating No fresh water supply | Further operation possible with restrictions Call service technician |
| 121 | Door not closed | Door open I/O circuit board defective Microswitch defective Microswitch not set correctly | Close door Call service technician |
| 122 | Incorrect password/no authorization | Code entered incorrectly | Enter code again |
| 123 | Factory settings of parameter list | Switching supply voltage on/off | No intervention by operator necessary Message disappears after 5 min. |
| 126 | Maintenance required | Set operating hours (P 122) or batch number | Further operation possible |

| INFO | Description | Possible cause | Measures/remedy |
|------|--|--|---|
| | | (P 123) has been reached | Call service technician |
| 325 | Drain pump active after triggering of safety level | Wash tank overfilled | Wait until machine is drained |
| 420 | Lack of rinse aid (with fill-level detection integrated) | Canister empty Suction lance not inserted correctly | Replace empty canister Check suction lance Vent pipes, if necessary |
| 520 | Lack of detergent (with fill-level detection integrated) | | |

| ERR | Description | Possible cause | Measures/remedy |
|-----|---|--|--|
| 001 | EEPROM error | EEPROM not available/defective, incorrectly plugged in, incorrect data, empty | Further operation not possible Call service technician |
| 111 | Leakage in base drip tray | Leak in feed hose Drain hose not connected correctly to drain | Replace feed hose, if necessary Check drain hose |
| 118 | Signal of the two door contact switches not the same | Malfunction/defect of door contact switch | |
| 201 | Boiler level not reached during first filling (with pressure booster pump integrated) | Fresh water supply not sufficient (water supply valve closed) Feed hose | Check water supply Check feed hose Check pre-filter/strainer and clean, if necessary |
| 202 | Boiler level not reached on time during filling (with pressure booster pump integrated) | kinked/loose/leaking Incoming water strainer dirty Solenoid valve defective Boiler switch defective | Call service technician, if necessary |
| 203 | No changed detected at boiler level switch when emptying (with | Pressure booster pump defective Connections (e.g. pressure | Further operation not possible |

| ERR | Description | Possible cause | Measures/remedy |
|------------|--|--|--|
| | pressure booster pump integrated) | booster pump) loose Starting capacitor defective | Call service technician |
| 204 | No change yet detected at boiler level switch (with pressure booster pump integrated) after rinse time expired | Boiler level switch defective No signal for pressure booster pump on - from I/O circuit board No signal for boiler full - from I/O circuit board | |
| 205 | Boiler temperature not reached after max. heating time (P310) | Boiler heating defective/welding beads on heater Temperature sensor defective, incorrect mounting position Boiler contactor defective, circuit breaker triggered No signal from I/O circuit board | Further operation not possible Call service technician |
| 206 | Wash time increase | Boiler not ready on time for final rinse (temperature or level not reached) Boiler heating defective (welding beads) Temperature sensor defective Boiler contactor defective, circuit breaker triggered No signal from I/O circuit board | Acknowledge message, further operation possible Allow the program to end without operator intervention Call service technician if this occurs more often |
| 210 | Short-circuit of boiler temperature sensor | Sensor defective Sensor position not correct | Further operation not possible Call service technician |
| 211 | Interruption of boiler temperature sensor | Plug contact not connected properly | |
| 212 | "Actual" boiler temperature too high (>95°C) | Contactors contact sticking Incorrect sensor/defective sensor | |

| ERR | Description | Possible cause | Measures/remedy |
|------------|---|---|--|
| 301 | Number of circulatory pumping cycles for tank filling exceeded Tank level analysis disrupted | Supply water pressure too low Incoming water strainer dirty Rinse nozzles dirty Air gap dirty Condensate in level pipe Feed hose kinked/loose/leaking | Check water supply Check feed hose Clean incoming water strainer Clean rinse nozzles Call service technician, if necessary |
| 302 | While draining during the wash program, the level does not fall below tank level 1 on time (with drain pump integrated) | Capacity of drain pump too low Drain pump dirty/defective Impeller loose Connections of drain pump loose | Further operation not possible Call service technician |
| 303 | While draining during the wash program, the level does not fall below tank level 3 on time (with drain pump integrated) | Starting capacitor defective, tank level analysis disrupted Aquastop does not close correctly No signal from I/O circuit board | Call service technician |
| 304 | Tank temperature not reached after max. heating duration (P314) | Tank heating defective/welding beads on heater Temperature sensor defective, incorrect mounting position Tank contactor defective, circuit breaker triggered | Further operation not possible Call service technician |
| 305 | Number of boiler fills insufficient for rinsing. Tank level 2 not reached | Supply water pressure too low Incoming water strainer dirty Rinse nozzles dirty Air gap dirty Condensate in level pipe Feed hose kinked/loose/leaking Level sensor defective Plug contact not connected properly | Check water supply Check feed hose Clean incoming water strainer Clean rinse nozzles Call service technician, if necessary |





| ERR | Description | Possible cause | Measures/remedy |
|-----|---|--|---|
| 306 | Max. tank level exceeded. Tank level analysis disrupted | Air gap dirty Condensate in level pipe Level sensor defective Plug contact not connected properly | Drain dishwasher and refill Call service technician |
| 307 | Tank level sensor defective | Connector loose Sensor or I/O circuit board defective | Call service technician |
| 310 | Short-circuit of temperature sensor | Sensor defective Sensor position not correct | Further operation not possible Call service technician |
| 311 | Interruption of temperature sensor | Plug contact not connected properly | |
| 312 | Actual tank temperature too high (>85°C) | Contacting contact sticking Incorrect sensor/defective sensor | |

Please contact your authorized MEIKO customer service if:

- There is an issue with the dishwasher, but no error code is displayed, OR
- An error code is displayed that is not listed here, OR
- The listed measures cannot solve the problem.

For a list of authorized customer service points, please either scan the QR code on the back cover of these operating instructions, visit our website at www.meiko.us or give us a call at (800) 868-3840.

10.6 Modifying the settings

| Key | Meaning | Key | Meaning |
|---|---|---|--|
|  | STOP key <ul style="list-style-type: none"> • Starts programming |  | START key <ul style="list-style-type: none"> • Confirms entry and jumps to next position in the code |
|  | Program key 1 <ul style="list-style-type: none"> • Increases value by one |  | Program key 2 <ul style="list-style-type: none"> • Decreases value by one |



Code
1

1. Press the **STOP** key for approx. 5 seconds until **CodE 1----** is displayed.



2. Enter the code for the required level. For level 1, it is sufficient to press the **START** key 5 times.

Level 1: Advanced settings (code 11111)

Level 2: Dosing settings (code 40044)



After entering the correct code, the desired level (1, 4) is displayed in the left field at the first digital position.



If the entry is incorrect, the **Info 122** message appears.

10.7 Level 1

| Code display | Meaning |
|--------------|---|
| | View parameter, see page 57. |
| | Vent (prime) rinse pipe, see page 58. |
| | Vent (prime) detergent pipe, see page 58. |

10.7.1 Viewing the parameters



1. Switch to **level 1 (11111)**, .



2. Select entry 1-1.



3. Confirm the selection.



The first parameter is displayed.

















4. Scroll through and view the parameters using the wash program keys.



Level 1 can be exited with the **on/off** key.

10.7.2 Venting (priming) the pipes

| | |
|---|---|
|   | <p>1. Press the STOP key for approx. 5 seconds until CodE 1----- is displayed.</p> |
|   | <p>2. Press the START key 5 times until 1-1 ----- is displayed.</p> |
|   | <p>3. Press the program key I. 1-2 ----- is displayed.</p> |
|   | <p>4. Press the START key. Priming of the rinse pipe will start. The time remaining is displayed. By default, priming takes 180 seconds.</p> |
|   | <p>5. If the time has expired and 1-2 --- -- is displayed, press program key I. 1-3 ----- is displayed.</p> |
|   | <p>6. Press the START key. Priming of the detergent pipe will start. The time remaining is displayed. By default, priming takes 30 seconds.</p> |
|   | <p>7. If the time has expired and 1-3 --- -- is displayed, press the STOP key to switch the machine off.</p> |

10.8 Level 2

Switch to level 2 (40044), see page 59.

The parameters relevant for the dosing technology are displayed and can be changed.

| Para. | Definition | Adjustment range / Setting |
|-------------|---|---|
| P104 | Dosing quantity for rinse aid | 0.10–1.00 ml/l (0.20 is the default setting) |
| P105 | Dosing quantity for detergent | 0.10–20.0 ml/l (2.00 is the default setting) |
| P218 | Lack of rinse aid indication | 1/0 = Display on/off (Note: must be set to 0) |
| P219 | Lack of detergent indication | 1/0 = Display on/off (1 is the default setting) |
| P224 | Activation mode for rinse aid dosing unit | 0 = Do not activate (Should only be selected if not using rinse aid!) 1 = Activate through calculated runtime (default setting) Note: settings 2 or 3 must NEVER be used on this model! |
| P225 | Activation mode for detergent dosing unit | 0 = Do not activate 1 = Activate through calculated runtime 3 = Activate like wash pump (only used if utilizing an external dispensing system) Note: Setting 2 must NEVER be used on this model! |
| P321 | Capacity of rinse aid dosing unit | 0.10–10 l/h - Must be set to 1.3 l/h |
| P322 | Capacity of detergent dosing unit | 0.10–20 l/h - Must be set to 7.0 l/h |
| P326 | Vent (priming) time for rinse pipe | 0–255 s (180 s is the default setting) |
| P327 | Vent time (priming) for detergent pipe | 0–100 s (30 s is the default setting) |

11 Cleaning

11.1 Cleaning the interior

⚠ CAUTION - Danger of burns from hot machine parts

- Allow the machine to cool down before cleaning.
- Wear protective gloves, if necessary.
- Only use the handles provided for opening or closing.

⚠ CAUTION – Property damage to electrics due to water ingress

- Never wash the machine, control cabinets and other electrical components using a water hose or high-pressure cleaner.
- Make sure that no water can enter the machine unintentionally.
- If installed at ground level, never flood the surrounding room.



IMPORTANT

Do not use a foaming hand dishwashing detergent for pre-cleaning the dishes. Do not use detergents or stainless steel cleaning agents on the interior of the machine. Foam causes malfunctions and poor washing results.

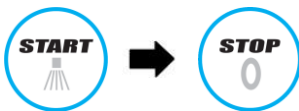

1. Switch off and drain the machine, see page 49.

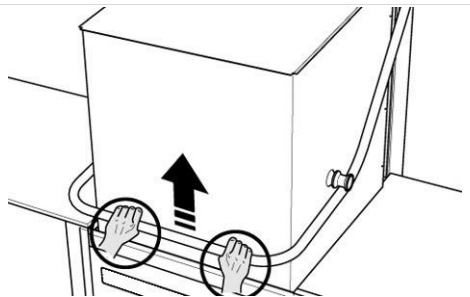

2. Open the door.

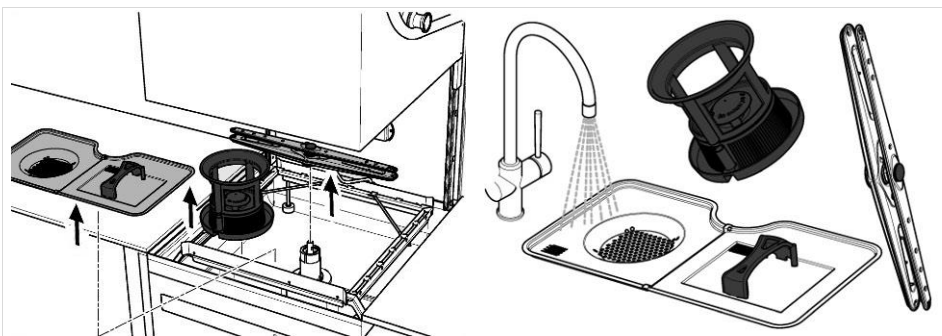

3. Remove the tank cover sieve, filter, rinsing arms and rinse arms (also the upper ones!).

5. Remove all food residues sticking to the tank, the tank heater and the sieves using a brush. Clean the nozzles of the rinsing and rinse arms.

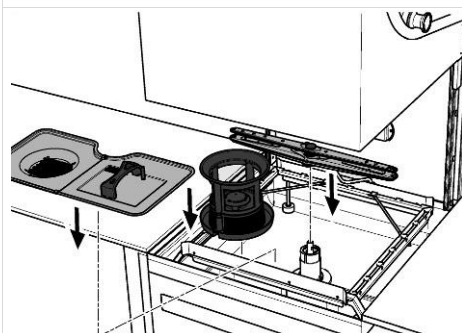

4. Reinstall all parts in reverse order. MEIKO recommends leaving the door open slightly overnight.

11.2 Cleaning the membrane keypad

Clean the membrane keypad using a damp cloth.

IMPORTANT - Make sure that the membrane keypad does not contact any stainless steel cleaning agents as this may result in damage to the membrane keypad.

11.3 Cleaning the outer stainless steel surfaces



CAUTION – Property damage to stainless steel due to incorrect cleaning

Cleaning of stainless steel parts using inappropriate detergents, care products and cleaning utensils leads to damage, deposits or discoloration on the machine.

- Never use aggressive detergents or abrasives.
- Never use detergents that contain hydrochloric acid or chlorine-based bleachers.
- Do not use cleaning utensils previously used to clean non-stainless steel.

Clean the outside of the dishwasher, especially the door handle, once a day. Clean stainless steel surfaces with cleaning agents suitable for stainless steel only.

11.4 Cleaning the surrounding area

- Do not use aggressive detergents (e.g. aggressive tile cleaners).
- Make sure that no water can enter the machine unintentionally.
- Do not flood the surrounding area.

11.5 Descaling



WARNING – Danger of injury from contact with acids

- Observe the safety data sheets and dosing recommendations of the chemical manufacturers.
- Use safety eyewear.
- Wear protective gloves.
- Remove descaler residues from all parts of the machine without delay to avoid damage.

Operating the dishwasher using hard water causes lime scale deposits to occur on the boiler interior and tank interior. Descale the inside of the tank, if necessary.

The boiler can be descaled by a service technician only.

Operating the dishwasher using hard water can cause lime scale deposits to occur in the boiler interior and tank interior. If this occurs, it is necessary to descale the tank interior, the boiler casing, the tank heating, the boiler heating and the wash and rinse systems.

Notes on descaling:

- For descaling, only use products suitable for commercial dishwashers. Follow the manufacturer instructions.
- Completely flush the descaling agent out of the dishwasher. To do so, perform 3–6 wash cycles without a rack. Any remaining descaling agent residues must be removed using a soft cloth and hot water. Then, perform a final wash cycle.
- Drain the dishwasher at the end of the descaling process.
- Assign the task of descaling the boiler to the customer service, if necessary.

12 Maintenance



WARNING – Danger to life from electric shock

- Work on the electrical system must only be conducted by qualified personnel who comply with the electrotechnical rules.
- Disconnect the machine from the power supply before removing any casing parts or working on the electrical system. To do this, turn the local main switch to **OFF** and ensure that it cannot be switched back on again.
- Attach all housing parts again before switching on the voltage again.



WARNING – Danger of injury when entering a danger zone

- Only qualified personnel may work on the machine.
- Remove unauthorized persons from the danger zone.
- Block off the danger zone and mark it for third parties.
- Always wear cut-resistant protective gloves when removing casing parts or working inside the machine.



CAUTION – Danger of burns from hot wash water, hot washware and hot machine parts

- Wear protective gloves, if necessary.
- Let the washware cool down before emptying, if necessary.
- Let the machine cool down before touching machine parts, if necessary.
- Never open the door during a wash cycle.
- Only open and close the door using the designated handle(s).



IMPORTANT

Environmental damage due to improper disposal of liquids

Environmentally hazardous liquids may be used during work on the machine. Improper disposal of these liquids can cause environmental damage.

- Always capture, store and transport liquids in suitable containers.
- Never mix liquids.
- Dispose of liquids properly in accordance with local requirements.

12.1 Maintenance work



IMPORTANT

Maintenance work must only be carried out by an authorized in-house technician or an authorized service technician.

MEIKO recommends having the machine serviced by an authorized service technician at least once a year and concluding a maintenance contract. As part of the maintenance, an electrical safety inspection is also carried out. Wear parts are checked and replaced, if necessary, and the machine is tested. Neglected or improper maintenance increases the residual risk of unforeseen damage to property and persons, for which no liability will be assumed.

Wear parts include, for example:

- Dosing hoses
- Door seal
- Supply water hose

12.2 Maintenance table

| Maintenance work | Checke | Cleaned | Replace | Maintenance requirement (minimum) |
|--|--------|---------|---------|-----------------------------------|
| 1. Pumps | | | | |
| Check pumps for leaks and any visible damage | | | | Once a year |
| Check pumps for running noise and correct function | | | | Once a year |
| Check pump sieves for correct seating/function | | | | Once a year |
| Check slide ring sealing/counter ring | | | | Once a year |
| 2. Wash systems | | | | |
| Check water level in tank | | | | Once a year |
| Check wash water pipe for leaks | | | | Once a year |
| Check that wash arm is complete and generates correct spray pattern | | | | Once a year |
| Check rotating arm hub | | | | Once a year |
| 3. Fresh water final rinse | | | | |
| Check flow water pressure | | | | Once a year |
| Check that rinse system is complete and generates correct spray pattern | | | | Once a year |
| Check system for leaks | | | | Once a year |
| 4. Casing and built-in components | | | | |
| Check the housing, tank, sheet metal body, door and sub-structure cover for damage and correct operation | | | | Once a year |

| Maintenance work | | | | Checke | Cleaned | Replace | Maintenance requirement (minimum) |
|---|----|-----|-------|---------------|----------------|----------------|--|
| Check tank cover sieves | | | | | | | Once a year |
| Check boiler, hoses, clamps, plastic parts and seals | | | | | | | Once a year |
| 5. Fresh water installation | | | | | | | |
| Check level control | | | | | | | Once a year |
| Check valves, clean dirt trap | | | | | | | Once a year |
| Check that all taps (incl. hand sprayer) are watertight | | | | | | | Once a year |
| For partial/full demineralization: check function | | | | | | | Once a year |
| For GiO MODULE: Replace pre-filter | | | | | | | Every 6 months |
| 6. Wastewater installation | | | | | | | |
| Check for tightness | | | | | | | Once a year |
| For drain pumps, check pressure hose position and draining behavior | | | | | | | Once a year |
| 7. Electrical installation | | | | | | | |
| Check all fuses | | | | | | | Once a year |
| Check tank and boiler heating | | | | | | | Once a year |
| Check temperature controller and limit switch | | | | | | | Once a year |
| 8. Electrical safety check (optional certificate) | | | | | | | |
| Perform visual check | | | | | | | Once a year |
| Check protective conductor | | | | | | | Once a year |
| Measure insulation resistance | | | | | | | Once a year |
| Measure current on protective conductor | | | | | | | Once a year |
| 9. Detergent dosing | | | | | | | |
| Check dosing and correct quantity, if necessary | | | | | | | Once a year |
| Replace peristaltic hose and associated seals on the nozzles | | | | | | | Once a year |
| 10. Rinse aid dosing | | | | | | | |
| Check dosing and correct quantity, if necessary | | | | | | | Once a year |
| Replace peristaltic hose and associated seals on the nozzles | | | | | | | Once a year |
| 11. Test run with functional test of entire machine | | | | | | | |
| Check test wash and cleaning results | | | | | | | Once a year |
| Visually check entire machine for leaks | | | | | | | Once a year |
| 12. Water quality, temperature | | | | | | | |
| Drinking water | °F | gpg | µS/cm | | | | Once a year |
| Water quality after water treatment (if available) | °F | gpg | µS/cm | | | | Once a year |

13 Dismantling and disposal

In addition to valuable raw materials and recyclable materials, the packaging and the old machine may also contain substances that are harmful to health and the environment but were required for the function and safety of the old machine.

13.1 Disposal of packaging materials

All the packaging is made from recyclable materials. The following materials are used:

- Square timber frame
- Plastic sheeting (PE film)
- Foam material
- Cardboard packaging (edge protection)
- Packaging strap (steel strip)
- Packaging strap (plastic (PP))
- Transport safety bracket (stainless steel)



Note

The square timber frame consists of untreated raw pine/spruce wood. In order to guard against pests, country-specific import regulations may also stipulate the use of treated wood.

13.2 Dismantling and disposal of the old machine



WARNING – Risk of injury from contact with chemicals

- Observe the safety data sheets and dosing recommendations of the chemical manufacturers.
- Use safety eyewear.
- Wear protective gloves.
- Do not mix different chemical products.

- If necessary, wash machine parts, containers, dosing units and hoses using fresh water to remove chemical residues. Wear suitable clothing (gloves, safety glasses) for this.



The machine is marked with this symbol. Please observe the local regulations for proper disposal of your old machine.

The components should be separated based on the material and recycled.

14 Index

A

Accessing the utility connections 24

C

Change of products..... 18

Cleaning..... 60

 Descaling.....62

 Interior.....60

 Surrounding area.....62

Cleaning the interior..... 60

Cleaning the outer stainless steel
surfaces..... 62

Cleaning the surrounding area ... 62

Code entry..... 57

Commissioning..... 41

 Requirements.....41

Connecting the detergent and rinse
aid canisters..... 37

Connecting the dosing system.... 36

Connection

 Fresh water.....28

 Wastewater pipe.....29

D

Delivery contents..... 5

Descaling..... 62

Designation..... 5

Detergent..... 17

Detergent and rinse aid..... 17

Dismantling..... 67

Dismantling and disposal..... 67

Disposal of packaging materials . 67

Disposal of the old machine..... 67

Dosing units..... 18

E

Electrical installation.....25

Electromagnetic compatibility..... 12

F

Functional description..... 12

G

Guarantee..... 7

I

Illustration..... 6

Install WAHR option..... 31

Installation..... 21, 24

Intended use..... 7

L

Level 1..... 57

Level 2..... 59

M

Maintenance..... 65

Maintenance table..... 65

Malfunctions..... 51

Membrane keypad..... 13, 61

Messages..... 52

Misuse..... 7

Modifying the settings..... 56

N

Noise emission..... 19

Notes on the operating instructions
..... 5

O

| | |
|----------------------------|----|
| Operation/use | 43 |
| Overview illustration..... | 13 |

P

Parameters

| | |
|------------|----|
| View | 57 |
|------------|----|

| | |
|--------------------------------------|----|
| Parts supplied for installation..... | 31 |
|--------------------------------------|----|

| | |
|--------------------------------|----|
| Performing commissioning | 42 |
|--------------------------------|----|

| | |
|-------------------|----|
| Preparation | 43 |
|-------------------|----|

| | |
|-------------------------|----|
| Priming the pipes | 42 |
|-------------------------|----|

| | |
|---------------------------|----|
| Product description | 12 |
|---------------------------|----|

Program

| | |
|-----------------|----|
| Assignment..... | 15 |
|-----------------|----|

Programs

| | |
|--------------|----|
| DV 80.2..... | 15 |
|--------------|----|

R

| | |
|--------------------|----|
| Rating plate | 15 |
|--------------------|----|

| | |
|-------------------------|---|
| Related documents | 5 |
|-------------------------|---|

| | |
|-------------------------------|----|
| Replacing the canisters | 50 |
|-------------------------------|----|

| | |
|--|----|
| Requirements for the electrical connection..... | 23 |
|--|----|

| | |
|---|----|
| Requirements for the fresh water connection..... | 22 |
|---|----|

| | |
|--|----|
| Requirements for the installation location..... | 21 |
|--|----|

| | |
|----------------------------------|----|
| Requirements for the personnel . | 10 |
|----------------------------------|----|

| | |
|--|----|
| Requirements for the wastewater connection..... | 21 |
|--|----|

| | |
|-----------------|----|
| Rinse aid | 17 |
|-----------------|----|

S

| | |
|--------------|---|
| Safety | 7 |
|--------------|---|

| | |
|--------------------------|---|
| Safety information | 8 |
|--------------------------|---|

| | |
|------------------------------------|----|
| Safety notices on the machine | 10 |
|------------------------------------|----|

| | |
|-------------------------------------|---|
| Safety symbols in the instructions. | 7 |
|-------------------------------------|---|

| | |
|---------------------|----|
| Switching off | 49 |
|---------------------|----|

| | |
|--------------------|----|
| Switching on | 43 |
|--------------------|----|

T

| | |
|-------------------------|----|
| Tabling attachment..... | 38 |
|-------------------------|----|

| | |
|----------------------|----|
| Technical data | 19 |
|----------------------|----|

| | |
|------------------------------------|----|
| Terminating the installation | 41 |
|------------------------------------|----|

| | |
|-----------------|----|
| Transport | 20 |
|-----------------|----|

U

| | |
|--|----|
| Useful information for loading the washware | 45 |
|--|----|

V

| | |
|-----------------------------------|----|
| Venting (priming) the pipes | 58 |
|-----------------------------------|----|

| | |
|-------------------------|----|
| Venting the pipes | 42 |
|-------------------------|----|

W

| | |
|---------------------|----|
| Wash programs | 15 |
|---------------------|----|

Washing

| | |
|----------------------------------|----|
| Selecting the wash program | 46 |
|----------------------------------|----|

| | |
|-------------------------------|----|
| Starting the wash cycle | 47 |
|-------------------------------|----|

| | |
|----------------------------------|----|
| Starting up the dishwasher | 45 |
|----------------------------------|----|

| | |
|------------------------------|----|
| Unloading the washware | 48 |
|------------------------------|----|

| | |
|---------------------------------|----|
| Wastewater temperature control. | 30 |
|---------------------------------|----|

| | |
|---|----|
| What to do in the event of an emergency..... | 10 |
|---|----|



Scan QR code to access MEIKO U.S. ASA listings.
ASA listing can also be accessed at
www.meiko.us



**MEIKO Maschinenbau
GmbH & Co. KG**
Englerstraße 3
77652 Offenburg
Germany
www.meiko-global.com
info@meiko-global.com

MEIKO USA, Inc.
1349 Heil Quaker Boulevard
La Vergne, TN 37086
Phone (615) 399-6600
Toll Free (800) 55 MEIKO
Fax (615) 399-6620
sales@meiko.us
24H Toll Free Service +1 800
868 3840
service@meiko.us

Design and construction subject to change without prior notice!

Quick programming instructions

DV 80.2 (USA)



03.23/K-PROG_DV80.2_9022057_EN-US_2020-04.docx

Keyboard use during programming

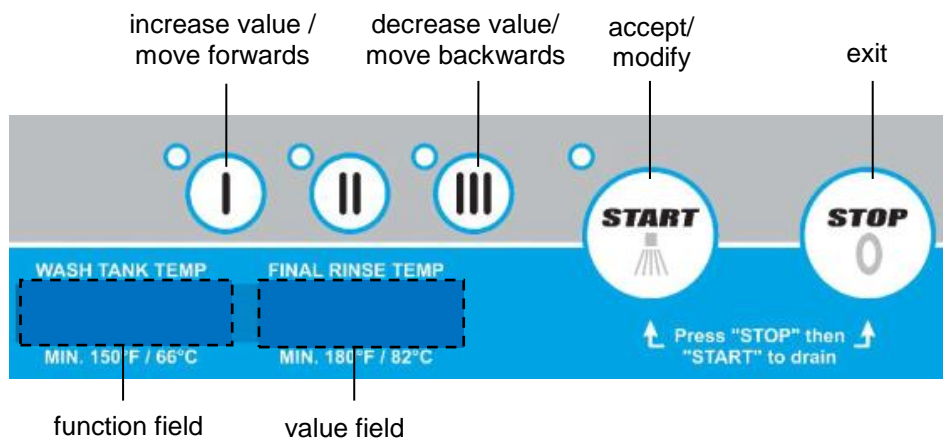

General:

In order to program the drive, the power supply must be ensured, and the machine must be completely switched off (no LED must be lit).

Code – entry:

View service data: **CODE 10000**

Modify service data: **CODE 10001**



To get into the code entry mode, you should keep the "0" key pressed (for around 3 seconds) until you see **Code 1----** on the display unit. By pressing the "0" key once again, you can leave the programming area at any time.

The digit to be modified will flash. Using the key "I" will increase the display unit values, which will be accepted by using the "accept" key. You should select each of the digits in this way one after the other, until the code has been completely entered.

If your entry is incorrect, you will leave the code entry procedure, and the information code 122 will be displayed. If you enter all the digits correctly, you will arrive at the service level.

You can move forwards using the "I" key, and backwards using the "III" key.

The following main positions are available on the service level:

- 1-1 ---- View / modify parameters
- 1-2 ---- Ventilate rinse aid inlet
- 1-3 ---- Ventilate detergent inlet

View parameters:

1-1 ---- Accept the position using the "accept" key, or use the "I" or "III" keys to select the parameters. On the left, the parameter Pxxx will be displayed, and on the right, the value belonging to it. You can use the "0" key to go back one level.



Modify parameters:

1-1 ---- Choice of parameters as when viewing, but access is via code for "modify service data".

To modify one of the parameters, select it by using the "accept" key – the value will flash.

Select the value by using the "I" key or the "III" key, and save using the "accept" key. You can leave the current level and go back to the previous level by using the "0" key.

- Ventilate rinse aid inlet** 1-2 ----
- Ventilate detergent inlet** 1-3 ----

Select the position you require. The selected dosing pump will be energized and the remaining running time will be displayed.



Exit the ventilation program by using the "exit" key.

Information/ error display:



If you receive an information message, you must follow the instructions. The wash operation will still be possible.



If you receive an error message, no further wash operation is usually possible. Notify customer service.

Parameter mode

Attention: the modification of factory set parameters may cause the restricted overall operation of the machine. In case of arbitrary modification of parameters by unauthorized personnel, guarantee claims will become invalid.

| Par. no. | Service parameters/ setting options | Use as | Value range | Unit | Factory setting | Observation |
|----------|---|-----------|----------------|--------------------|-----------------|--|
| 101 | Wash program / key 1 | Parameter | 1 .. 50 | - | 1 | Assign wash program no. to key 1; verification adjustable |
| 102 | Wash program / key 2 | Parameter | 1 .. 50 | - | 2 | Assign wash program no. to key 2; verification adjustable |
| 103 | Wash program / key 3 | Parameter | 1 .. 50 | - | 3 | Assign wash program no. to key 3; verification adjustable |
| 104 | Rinse aid dosing quantity | Parameter | 0,10 .. 1,00 | ml/liters of water | 0.2 | Value must be set approximately according to manufacturer's information, then it must be corrected depending on the water hardness and the wash result. |
| 105 | Detergent dosing quantity | Parameter | 0,1... 20,0 | ml/liters of water | 2.0 | Value must be set approximately according to manufacturer's information, then it must be corrected depending on the water hardness and the wash result. |
| 107 | Switch beep on / off | Parameter | 0/1 | - | 1 | Switch acoustic ready message on / off by beep |
| 111 | Total operating time display | Display | 5-digit | Hrs. | 0 | Operating time, query only |
| 112 | Total number of wash cycles | Display | 5-digit | - | 0 | wash cycles / loads, query only |
| 113 | Number of wash cycles since last reset | Display | 5-digit | - | 0 | wash cycles / loads, resetting possible |
| 114 | Serial number | Display | 8-digit | - | Serial number | Possibility of querying factory settings Attention: the first 5 digits will be displayed in rotation with the last 3 digits! |
| 120 | Load factory setting service parameters | Parameter | 0/1 | - | 0 | Effective only upon power supply reset ON / OFF. Attention! All changes to service parameters will be reversed. Power supply reset must be carried out within 5 minutes, otherwise factory settings will not be loaded. Without power supply reset, the information 123 will be displayed. |

Wash program parameters 101-103

| Wash program no.: | Boiler temperature target value [°F] | Wash time target value | |
|-------------------|--------------------------------------|------------------------|-----------|
| | | Washing [s] | Total [s] |
| 1 | 185 | 41 | 66 |
| 2 | 185 | 65 | 90 |
| 3 | 185 | 185 | 210 |

Details of further pre-defined wash programs are given in the Service Instructions.