



## **MHC-22 Holding Cabinet Items 86002 & 86003**

---

### **Service, Installation and Operation Manual**

Please read this manual completely before attempting to install or operate this equipment!

Notify carrier of damage!

Inspect all components immediately.



**Important Information**  
**Read Before Use**  
**Please Save These Instructions!**

February 2014



## Important Warning And Safety Information



WARNING

Read This Manual Thoroughly Before Operating, Installing, Or Performing Maintenance On The Equipment.



WARNING

Failure To Follow Instructions In This Manual Can Cause Property Damage, Injury Or Death.



WARNING

Do Not Store Or Use Gasoline Or Other Flammable Vapors Or Liquids In The Vicinity Of This Or Any Other Appliance.



WARNING

Unless All Cover And Access Panels Are In Place And Properly Secured, Do Not Operate This Equipment.



WARNING

This Appliance Is Not Intended For Use By Persons Who Lack Experience Or Knowledge, Unless They Have Been Given Supervision Or Instruction Concerning Use Of The Appliance By A Person Responsible For Their Safety.



WARNING

This Appliance Is Not To Be Played With.



WARNING

Do Not Clean With Water Jet.



WARNING

Do Not Use Electrical Appliances Inside The Food Storage Compartment Of This Appliance.



CAUTION

Observe the following:

- Minimum clearances must be maintained from all walls and combustible materials.
- Keep the equipment area free and clear of combustible material.
- Allow adequate clearance for air openings.
- Operate equipment only on the type of electricity indicated on the specification plate.
- Unplug the unit before making any repairs.
- Retain this manual for future reference.

## Contents

Receiving & Inspecting The Equipment .....	3
Serial Number Information .....	4
Warranty Information.....	4
Regulatory Certifications.....	4
Specifications .....	5
Installation.....	6
Control Panel.....	7
Operation.....	8
Quick-Start Programming Instructions .....	9-12
Maintenance .....	13-14
Application Guide .....	15
Personalized Product Settings.....	16
Troubleshooting .....	17
Diagnostic Mode .....	18
Wiring Diagram.....	19
Sequence Of Operation .....	19
Replacement Parts.....	20
Replacement Instructions .....	21
Notes .....	22-23

## Receiving And Inspecting The Equipment

Care should be taken during unloading so the equipment is not damaged while being moved into the building.

1. Visually inspect the exterior of the package and skid or container. Any damage should be noted and reported to the delivering carrier immediately.
2. If damaged, open and inspect the contents with the carrier.
3. In the event that the exterior is not damaged, yet upon opening, there is concealed damage to the equipment notify the carrier. Notification should be made verbally as well as in written form.
4. Request an inspection by the shipping company of the damaged equipment. This should be done within 10 days from receipt of the equipment.
5. Check the lower portion of the unit to be sure legs are not bent.
6. Freight carriers can supply the necessary damage forms upon request.
7. Retain all packaging material until an inspection has been made or waived.

## Serial Number Information

MHC-22 holding cabinet serial numbers are located on the data plate that also includes the model number. The data plate is located on the rear of the unit.

**Always have the serial number of your unit available when calling for parts or service.**

©2014 Merco. All rights reserved. Reproduction without written permission is prohibited.

## Warranty Information

Visit [http://www.mercoproducts.com/minisite/service/warranty\\_info](http://www.mercoproducts.com/minisite/service/warranty_info) to:

- Register your product for warranty.
- Verify warranty information.
- View and download a copy of your warranty.

## Regulatory Certifications

120V Models are certified by:



**Underwriters Laboratories Sanitation**



**Underwriters Laboratories (UL)**

**Underwriters Laboratories of Canada (ULC)**

230V Models are certified by:



**Underwriters Laboratories Sanitation**



**European Conformity**

**Technical Inspection Association**

## Specifications

Item/Sku	Model/Description	V-Hz-Ph	Watts	Amps	Plug Type	Net Wt. lbs/kg	Ship Wt. lbs/kg
86002	MHC-22	120-60-1	1250	10.4	NEMA 5-15P	30/14	35/16
86003	MHC-22, CE	230-50-1	1250	5.5	CEE 7/7	30/14	35/16

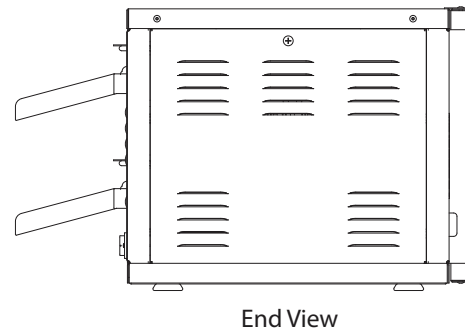
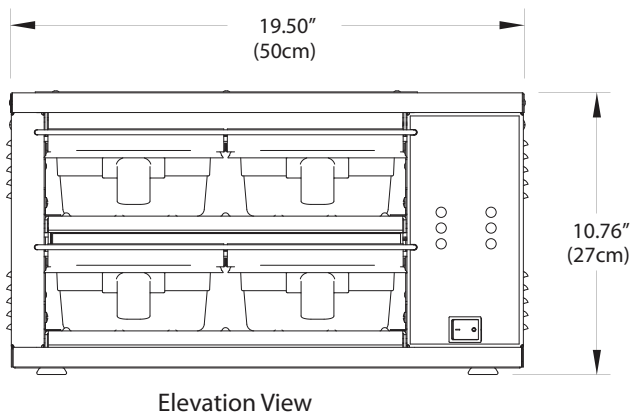
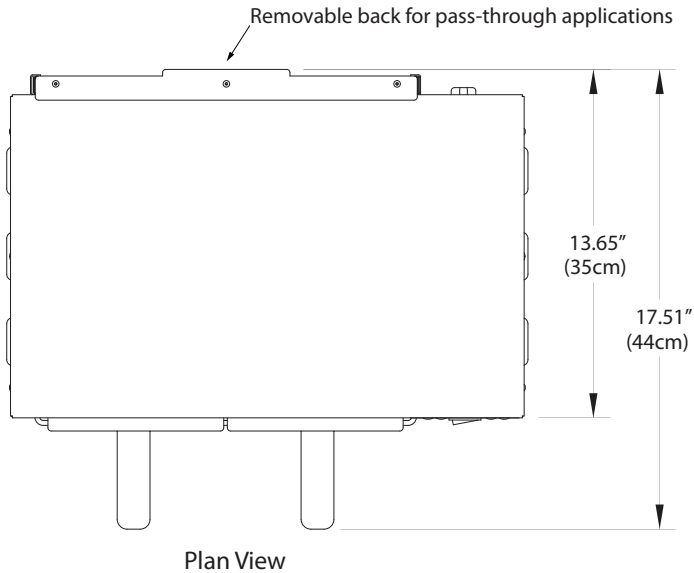

## Installation

### Site Preparation

Choose a well-ventilated location. Place the holding cabinet on a suitable table or counter capable of supporting the weight of 30 lbs. or 14 kg. The power supply must be in accordance with the specifications on the data plate located on the rear of the appliance. It should be installed on a dedicated service line with no other equipment on the circuit. The unit must be positioned so that the unit's plug is accessible.

### Installation Instructions

1. Remove legs from unit.
2. Place mounting brackets on either side of unit and attach by inserting the screws/washers (provided) into the holes left by the vacated legs. Tighten firmly.
3. With brackets securely attached to the unit, place the unit where it is to be mounted and mark the locations for stud placement.
4. Mount unit to shelf using hardware (not included) capable of handling the weight of unit.
5. With stud locations marked, attach studs with stud gun. Insert nut and washer on each stud then insert unit with mounting brackets followed by additional washers and nuts to complete the installation. NOTE: Studs should be 1/4-20 stainless steel. Studs, washers and nuts are not included.

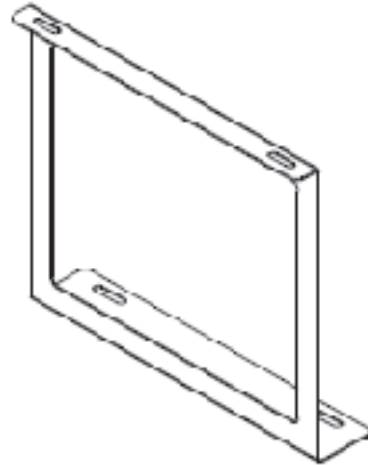

Mounting Kit contains (2) brackets, (4) screws & (4) washers

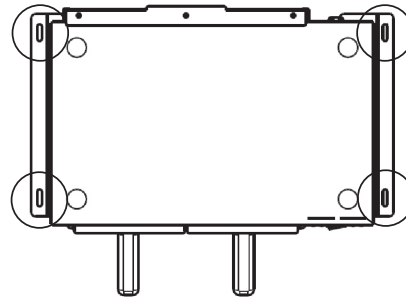

Hole locations to mark for stud placement

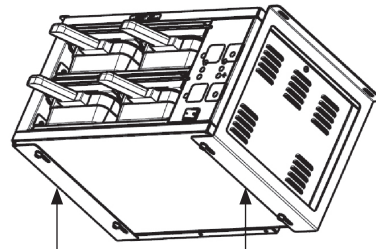

Mounting brackets on either side of unit

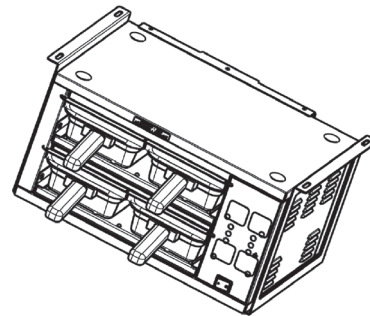

Unit with mounting kit attached

## Control Panel

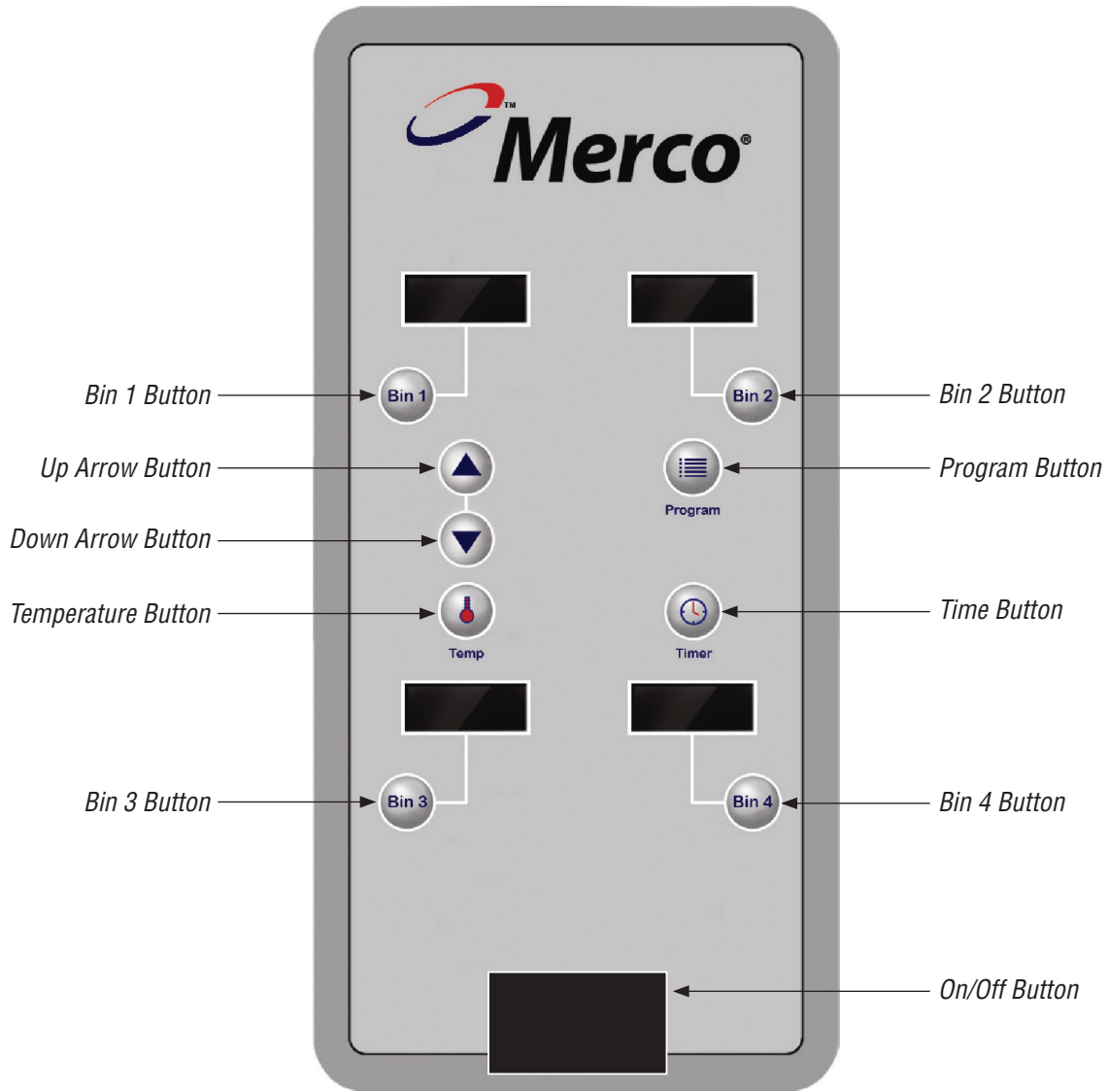

# Operation

The Merco Holding Cabinet has been designed to afford foodservice operators the ability to cook menu components in advance and then gently store that product in the holding bins until an order is received. Once that order has been placed, the crew can assemble the order using hot and fresh menu components from the holding bins. This allows for operators to serve to order, helping increase speed of service while maintaining high product quality standards.

The holding bin controller is, at all times, operating in one of three modes:

- Normal mode
- Programming mode
- Diagnostic mode

Instructions for each of these operating modes are detailed below.



If the supply cord appears to be damaged, do not attempt to operate unit. Contact service agent or qualified technician to repair.



When holding potentially hazardous foods, the minimum shelf temperature must be 220°F for the upper-bin heating element and 200°F for the lower-bin heating element.

## Normal Mode

This is the normal mode of operation. The product for each bin is displayed, timers are activated for loaded bins, alarms are generated for cook more and expired product.

### Typical Operator Actions

Action	Instructions
Turn Unit On	Push Power On/Power Off button. Green Power button will illuminate in on position.
Load bin with product and start timer	Pull out tray, load product and reinsert bin. Push and hold bin button. Bin display will change to show presence of product. Control will sound one short beep. Release hold of bin button.
Empty bin and stop timer	Pull out tray and remove product. Reinsert tray. Press and hold bin button. The bin display will indicate empty bin (----). Control will sound one short beep.

Action	Instructions
Silence Alarm for Cook or Dump	Locate bin displaying Attn and press the bin button. The alarm will be silenced. Bin will continue to indicate desired action: Cook (it is now time to cook additional product) or Dump (it is now time to discard product in bin).

## Normal Display Modes

Each bin display consists of two parts, a primary and secondary message word. These words are displayed one after the other, repeating regularly. The following sections describe the type of displays present under various conditions.

**Bin empty display:** Bin display shows product name followed by ---- to indicate that bin is empty.

**Bin loaded:** Bin display shows product name followed by a brief display of the time remaining until the product expires.

**Bin alarm for Cook More:** Bin display shows Attn and a brief Cook message. Once the alarm is silenced, the display will show the product name followed by Cook. This condition persists until the product expires or the bin is emptied.

**Bin alarm for Holding Time Expiration:** Bin display shows Attn followed by Dump. Once the alarm is silenced, the display indicates the product name followed by Dump. This condition persists until the bin is emptied.

## Programming Mode

See the next section, Quick Start Programming Instructions.

## Diagnostic Mode

See page 18.

## Quick-Start Programming Instructions

### Pre-Programmed Menu Items

For your convenience, the Merco Holding Cabinet has been pre-programmed with numerous food items that might be useful with your application. A complete listing of pre-programmed menu items and their respective settings can be found in the Application Guide section of this manual. If you decide to use any of these pre-programmed menu items, move directly to Part Four of the Quick-Start Programming Instructions listed below. If you wish to create a new menu item, please follow all four parts of the Quick-Start Programming Instructions listed below.

### Quick-Start Programming Instructions

This unit has the flexibility to provide the operator with numerous options throughout the programming process. The instructions on the following pages will help you to easily navigate through the basic process of setting up the food items and storing them to the desired bins. The information listed below has been formatted to provide you with a brief overview of what programming steps will be performed on the following pages. Please read this information first before beginning the process.

### Food Product Names

The MHC-22-GEN can hold up to 32 separate food items in memory. Each of these food items are programmed by the operator with various temperature, time, and bin location settings. These food items correspond to the four product storage bins of the unit.

For your convenience, a personalized product settings chart has been included on page 16. As menu items are stored and saved into memory, we recommend you note these individual settings in the chart for future reference.

### 1. Part One – Assigning A Food Item Name Into Memory

Part one allows you to create a food product name you wish to save in memory. The display allows for the use of up to four characters in assigning a name. So, if you wish to assign the food item bacon , you may want to save the name as BACN .

### 2. Part Two – Temperature Settings For Food Items

Food items may have unique temperature settings necessary to hold and maintain quality. As a result, temperature settings need to be assigned to each food item created.

### 3. Part Three – Time Settings For Food Items

Food items may also have unique time settings necessary to hold and maintain quality. As a result, separate cook time and dump time settings need to be assigned to each food item created.

### 4. Part Four – Assigning Food Item To A Storage Bin

At this point all the necessary characteristics have been assigned to the food product created. The last step in the process is to assign that food item (and its temperature and time setting characteristics) to the desired storage bin. Once this has been completed you are ready to go back to part one and create the next food item.

NOTE: When programming the unit, the operator will have a maximum of 14 seconds between programming steps before the unit will time out. If this happens the operator will be required to begin again with the first step in the part.



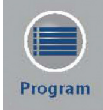
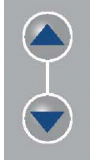
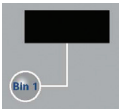
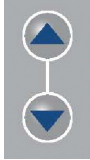
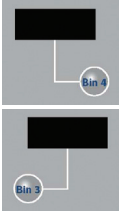
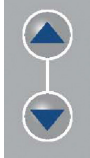
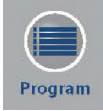



**Quick-Start Programming Instructions, continued**

Part One: Creating A Food Product Name		
Step	Button	Instruction
1		Press and hold Program button until you hear a short, double-beep sound. Release.
2		Press and hold Program button again until you hear a short, double-beep sound. Release.
3		Press Up Arrow button or Down Arrow button to locate the next available name slot (PD1, PD2, PD3, etc). This is where you create the name of the food item and save it to memory. For example, you may want to save bacn in place of PD2.
4		Press and release Bin 1 button. Display will flash.
5		Press Up Arrow button or Down Arrow button to change the first character in the name of the food item you wish to save into memory.
6		Press Bin 4 button to move to the next character in the name of the food item you wish to save. If you need to go back to a previous character, press Bin 3 button.
7		Press Up Arrow button or Down Arrow button to change the second character in the name of the food item you wish to save. Continue through steps 4 and 5 until finished with the last character of the name of food item. Remember there is a maximum of four available characters to spell item name.
8		Press and hold the Program button until you hear a short, double-beep sound to save setting and return to normal operating mode.

**Upper & Lower Temperature Settings For Food Product**

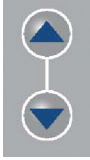
Each product bin has upper and lower heating elements that provide the heat necessary to hold your food product. It is critically important that each of these heat zones be set to the appropriate temperature for each type of food product you wish to store in the bins. The temperature settings for each of these bins will change with the type of food product being stored.

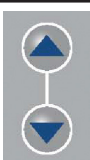

Part Two: Assigning Upper & Lower Temp Settings For Food Product		
Step	Button	Instruction
1		Press and hold Program button until you hear a short, double-beep sound. Release.
2		Press and hold Program button again until you hear a short, double-beep sound. Release.
3		Press Up Arrow button or Down Arrow button to locate desired product (displayed in Bin 1).
4		Press Temp button to make changes the lower temperature of the selected product.
5		Press Up Arrow button or Down Arrow button to set the lower temperature.
6		Press Temp button again to make changes the upper temperature.
7		Press Up Arrow button or Down Arrow button to set the upper temperature.

## Quick-Start Programming Instructions, continued

### Part Two: Assigning Upper & Lower Temp Settings For Food Product

Step	Button	Instruction
8		<p>Press and hold Program button until you hear a short, double-beep sound. Release. Lower and upper temperature settings for desired product have now been saved.</p> <p>Follow these steps each time (while selecting the appropriate product in step 3) to assign lower and upper temperature settings to each food product.</p>







### Food Product Cook Time And Dump Time

The MHC-22-GEN unit has been designed to provide the operator with two different types of alarms; Cook Time and Dump Time. The operator will assign these times to each type of food product being held.

**Cook Time Alarm:** This alarm has been designed to provide the operator advance warning that the product being held in the assigned bin is set to expire shortly. When this alarm sounds, the operator should begin preparing additional food to ensure there is no down time between preparing and providing food. The cook time alarm should be set for the time necessary to completely prepare additional product of this type.

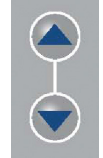

**Dump Time Alarm:** This alarm has been designed to provide the operator with a warning that the food product has reached the end of its shelf life and should be discarded. To insure the highest level of quality, food product should never be given to customers after the dump time alarm has sounded.

### Part Three: Assigning Cook Time And Dump Time Settings For Product

Step	Button	Instruction
1		Press and hold Program button until you hear a short, double-beep sound. Release.
2		Press and hold Program button again until you hear a short, double-beep sound. Release.
3		Press Up Arrow button or Down Arrow to scroll through the available names in memory until you reach the desired product name.
4		Press Time button to select Cook time setting.
5		Press Up Arrow button or Down Arrow to set the appropriate cook time. Note: Time characters are equal to hours and minutes. For example, 2:05 is equal to 2 hours and 5 minutes.
6		Press Time button to select Dump time setting.

**Quick-Start Programming Instructions, continued**

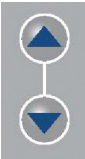
**Part Three: Assigning Cook Time And Dump Time Settings For Product**



Step	Button	Instruction
7		Press Up Arrow button or Down Arrow to set the appropriate Dump time. Note: Time characters are equal to hours and minutes. For example, 2:05 is equal to 2 hours and 5 minutes.
8		Press and hold Program button until you hear a short, double-beep sound. Release. The Cook time and Dump time settings have been saved. Follow these steps each time (while selecting the appropriate product in step 3) to assign Cook and Dump time settings to each product.

**Storage Bins For Food Product**

With the MHC-22-GEN unit, a total of 32 separate food items can be store in memory. Of these 32 food items, any combination of 4 food items may be made active at any one time. For example, all four bins could hold hamburger at the same time or they could be used to hold four separate food items.

The trays used to hold the food product in each bin are made of plastic and are dishwasher safe. These trays are also interchangeable between bins.

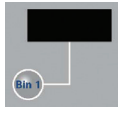
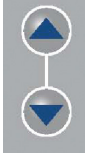
**Part Four: Assigning Food Product To A Storage Bin**

Step	Button	Instruction
1		Press and hold Program button until you hear a short, double-beep sound. Release.
2		Press Bin 1.
3		Press Up Arrow button or Down Arrow to scroll through the available names in memory until you reach the desired product name.
4		Press and hold Program button until you hear a short, double-beep sound. Release. The product name is now stored in Bin 1. Follow these steps each time (while selecting the appropriate bin in step 2) to assign product name to each of the 4 available bins.

The process of creating a food item, storing its characteristics, and assigning it to a bin are complete. Follow these steps again to create and assign additional food items.

## Maintenance



Disconnect power supply before servicing or cleaning this unit. Safeguard power so it cannot be accidentally restored. Failure to do so could result in serious injury.



Unit must be cool to touch and disconnected from power source prior to cleaning. Do not use power-cleaning equipment, steel wool, or wire brushes on stainless steel or painted surfaces.



This appliances plug is the disconnect device and, as such, the unit must be installed so that the plug is accessible.

Merco Holding Cabinets are designed for easy cleaning and minimum maintenance. The stainless steel outer case requires nothing more than a daily wiping with a damp cloth. If, however, an excessive amount of food particles/grease are allowed to collect, a non-abrasive cleaner (hot sudsy water) may be used. The Product Holding Bin and Bin Lid may be cleaned via dishwasher or with warm soapy water. Care must be taken to prevent water or cleaning compounds from getting on internal parts, especially the switches on the control panel.

### Bin Lid Removal Instructions

Note: The illustration below features a Merco MHC-1 (1-Bin Unit). These instructions also apply to the MHC-22 (2x2 Bin Unit).

1. Remove bin.



2. Gently pull retention rod.



3. Lower front of bin lid.



4. Remove bin lid.

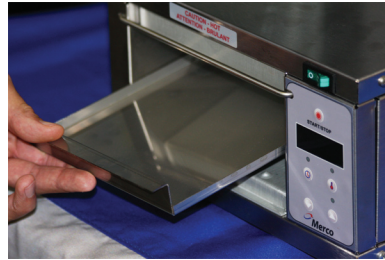

5. Instal in reverse order.

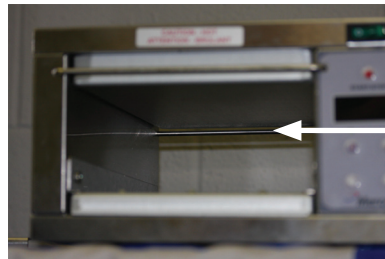

*Rear Retaining Rod*

Note: When installing the bin lid, be sure back end of lid rests on the rear retaining rod, otherwise the lid will not rest properly on the bin.

## Maintenance, continued

### Stainless Steel Care and Cleaning

To prevent discoloration or rust on stainless steel several important steps need to be taken. First, we need to understand the properties of stainless steel. Stainless steel contains 70-80% iron, which will rust. It also contains 12-30% chromium, which forms an invisible passive film over the steel's surface, which acts as a shield against corrosion. As long as the protective layer is intact, the metal is still stainless. If the film is broken or contaminated, outside elements can begin to breakdown the steel and begin to form discoloration or rust. Proper cleaning of stainless steel requires soft cloths or plastic scouring pads.

### **NEVER USE STEEL PADS, WIRE BRUSHES OR SCRAPERS!**

Cleaning solutions need to be alkaline based or non-chloride cleaners. Any cleaner containing chlorides will damage the protective film of the stainless steel. Chlorides are also commonly found in hard water, salts, and household and industrial cleaners. If cleaners containing chlorides are used be sure to rinse repeatedly and dry thoroughly. Routine cleaning of stainless steel can be done with soap and water. Extreme stains or grease should be cleaned with a non-abrasive cleaner and plastic scrub pad. Always rub with the grain of the steel. There are stainless steel cleaners available which can restore and preserve the finish of the steels protective layer. Early signs of stainless steel breakdown are small pits and cracks. If this has begun, clean thoroughly and start to apply stainless steel cleaners in attempt to restore the passivity of the steel.



**Never use an acid based cleaning solution! Many food products have an acidic content, which can deteriorate the finish. Be sure to clean the stainless steel surfaces of ALL food products. Common items include, tomatoes, peppers and other vegetables.**

### Plastic Tray Cleaning

Food-approved detergents can be used if they are diluted per manufacturer's directions and adequately rinsed away prior to high temp drying cycle. Basic alcohols such as isopropyl are acceptable for hard-to-remove stains. Otherwise, do not use organic solvents.

**Environmental stress cracking has occurred, proper dilution and rinsing per manufacturers' directions are mandatory.**

## Application Guide

The guide shown below contains food items that have been pre-programmed at the factory for your convenience. Please note that this is meant to be a guide and that minor adjustments may be necessary to meet your specific quality requirements.. We recommend that you test these items and adjust settings as needed.

<i>Product Code</i>	<i>Product Description</i>	<i>Entry Temp (°F)</i>	<i>Upper Temp (°F)</i>	<i>Lower Temp (°F)</i>	<i>Recommended Hold Time (mins)</i>	<i>Recommended Cook Time (mins)</i>
Eggs	Eggs	160	160	180	60	10
Bacn	Bacon	175	200	200	20	5
Hsh1	Hash Browns	180	200	200	15	5
Hsh2	Hash Browns (cover removed)	180	200	200	20	5
Bsct	Biscuits	170	200	200	60	10
Saus	Sausage Patties	180	200	200	240	15
Ham	Ham Steak	160	200	200	120	10
Dogs	Hot Dogs	180	200	200	240	15
Ch Br	Chicken Breasts	170	200	200	240	15
Burg	Hamburger Patties	175	200	200	240	15
Fish	Breaded Fish Fillets	180	190	190	45	10
Ck Pt	Breaded Chicken Patties	180	200	200	45	10
Mt Lf	Meat Loaf	180	220	220	120	10
Mt Bl	Meatballs	180	220	220	120	10
Past	Pasta	180	200	200	240	15
Veg	Vegetables	150	200	200	120	10
Frut	Fruit Compote	175	200	200	240	15
Chil	Chili	175	200	200	240	15
Spin	Spinach Dip	180	200	200	240	15
Mozz	Mozzarella Sticks	165	200	200	15	5
Popp	Poppers	175	200	200	15	5
PD22	n/a	n/a	200	200	240	15
PD23	n/a	n/a	200	200	240	15
PD24	n/a	n/a	200	200	240	15
PD25	n/a	n/a	200	200	240	15
PD26	n/a	n/a	200	200	240	15
PD27	n/a	n/a	200	200	240	15
PD28	n/a	n/a	200	200	240	15
PD29	n/a	n/a	200	200	240	15
PD30	n/a	n/a	200	200	240	15
PD31	n/a	n/a	200	200	240	15
PD32	n/a	n/a	200	200	240	15

## Personalized Product Settings

The following chart has been provided as a reference tool for future use if you decide to create new menu items separate from what have been pre-programmed. We recommend writing the food item characteristics in the chart below to use as a quick reference tool. You may want to revert back to this chart in the future to reference the different saved settings (product name, upper temp, lower temp, cook time, dump time).

<i>Product Code</i>	<i>Product Description</i>	<i>Upper Temp</i>	<i>Lower Temp</i>	<i>Cook Time</i>	<i>Dump Time</i>
PD01					
PD02					
PD03					
PD04					
PD05					
PD06					
PD07					
PD08					
PD09					
PD10					
PD11					
PD12					
PD13					
PD14					
PD15					
PD16					
PD17					
PD18					
PD19					
PD20					
PD21					
PD22					
PD23					
PD24					
PD25					
PD26					
PD27					
PD28					
PD29					
PD30					
PD31					
PD32					

## Troubleshooting

<i>Symptom</i>	<i>Possible Cause</i>	<i>Evaluation</i>
Holding Cabinet will not heat	Incoming Power Supply	Verify power cord is secured firmly in receptacle. Measure the incoming voltage. Check circuit breakers. Reset if required. Call power company if needed.
	Power Switch	Check continuity between switch terminals. Replace switch as needed.
Unit doesn't reach desired temperature	Thermocouple	Check for continuity in circuit.
	Heat Element	Compare cavity temperature with display reading. Insert temperature probe into center of cavity. Acceptable temperature variation is +/- 20° from display reading. Check for loose connection. Check the Amp draw on each element for proper load. Check page 5 for rating information. If the amp draw is high or low, check the individual elements for opens, shorts and proper resistance. WITH POWER OFF: To check resistance of the elements, remove all leads from the elements and use a digital multimeter. The element resistance should be 120V – 87 ohms. Replace heating element (shelf) as needed.
		Check thermostat (common wire). Please note that if thermostat is bad, both circuits will be bad.
Temperature is too high	Thermocouple	Check for incorrectly wired thermocouple. Thermocouple wire polarities are reversed.
	Heat Element	Compare cavity temperature with display reading. Insert temperature probe into center of cavity. Acceptable temperature variation is +/- 20° from display reading. Check for loose connection. Check the Amp draw on each element for proper load. Check page 5 for rating information. If the amp draw is high or low, check the individual elements for opens, shorts and proper resistance. WITH POWER OFF: To check resistance of the elements, remove all leads from the elements and use a digital multimeter. The element resistance should be 120V – 87 ohms. Replace heating element (shelf) as needed.
Display reads unusual characters		Make sure wires are connected properly (grounded).
		If wires are grounded properly, new control board is needed.
On/Off switch doesn't light (but unit works properly)	Power Switch	Check wiring to switch.

## Diagnostic Mode

Press and hold down the Temperature button until you hear a short, double-beep sound. In this mode all displays indicate temperatures for either the upper or lower heaters for each bin. Pressing the Up and Down arrow buttons will select the upper and lower heaters respectively.

In this mode, pressing the Time button will also display the PWM output power duty cycle. This is shown as a percent for the corresponding heater.

The thermocouple calibration system can only be accessed from within the diagnostic mode.

### Thermocouple Calibration System

Make sure heater zone to be calibrated is at temperature and stable. Measure actual temperature and proceed with following procedure.

Enter Diagnostic Mode by pressing and holding down the Temperature button. After a second or so, the actual temperatures as measured by holding cabinet are displayed.

Use Up or Down buttons to select either the upper or lower heating zone for each bin.

Press Bin select button to select bin containing heating zone to be calibrated.

Note: Bin display will alternate between showing temperature and calibration offset. As the calibration offset is changed the temperature displayed will reflect this.

Use the Up and Down buttons to make the displayed temperature match the actual temperature as independently measured.

To apply the temperature calibration correctly, press and hold the Temperature button down. While pressing the Temperature button, press Program button (for 1 second) until the unit beeps.

Once program is completed the temperature correction is applied and the heater zone will adjust its temperature. The user interface returns to the actual temperature display.

Once a bin is selected for programming, if no keys are entered for 10 seconds the calibration mode is terminated and the display returns to actual temperature display mode.

### Thermocouple Fault Detection

The thermocouple (TC) fault detection logic is disabled for 10 minutes following initial power application. This allows time for all heating zones to develop enough heat to not trigger a shorted thermocouple fault.

If a fault is detected in any bin, the display for that bin will show ErNN where NN is a numeric error code.

- This two digit error code (NN) uses the first digit for the upper heater zone
- The second digit of NN represents the lower heater zone.
- If a short is detected, the digit will be a 1.
- If an open is detected a 2 will be displayed.
- If the heater zone is operating properly, a 0 will be displayed.

<i>Example Code</i>	<i>Indicates</i>
Er01	Upper heater zone is good. Lower heater zone TC short detected.
Er02	Upper heater zone is good. Lower heater zone TC open detected.
Er10	Upper heater zone TC short detected. Lower heater zone is good.
Er20	Upper heater zone TC open detected. Lower heater zone is good.
Er22	Upper and Lower heater zone TC's detected open.
Cold	Temperature of heater zone is below set point.
Hot	Temperature of heater zone is above set point.

Once an error is indicated for a heater zone the affected heater is shut off.

The only way to clear an error indication is by cycling the power off then on again.

To reset the holding bin controller to the factory configuration, hold down the upper-left Bin button while powering on the controller. Release the Bin button as soon as the displays illuminate. This resets the following settings:

- All product names
- Upper and lower temperature for each product
- Expiration and Cook More time for each product

# Wiring Diagram

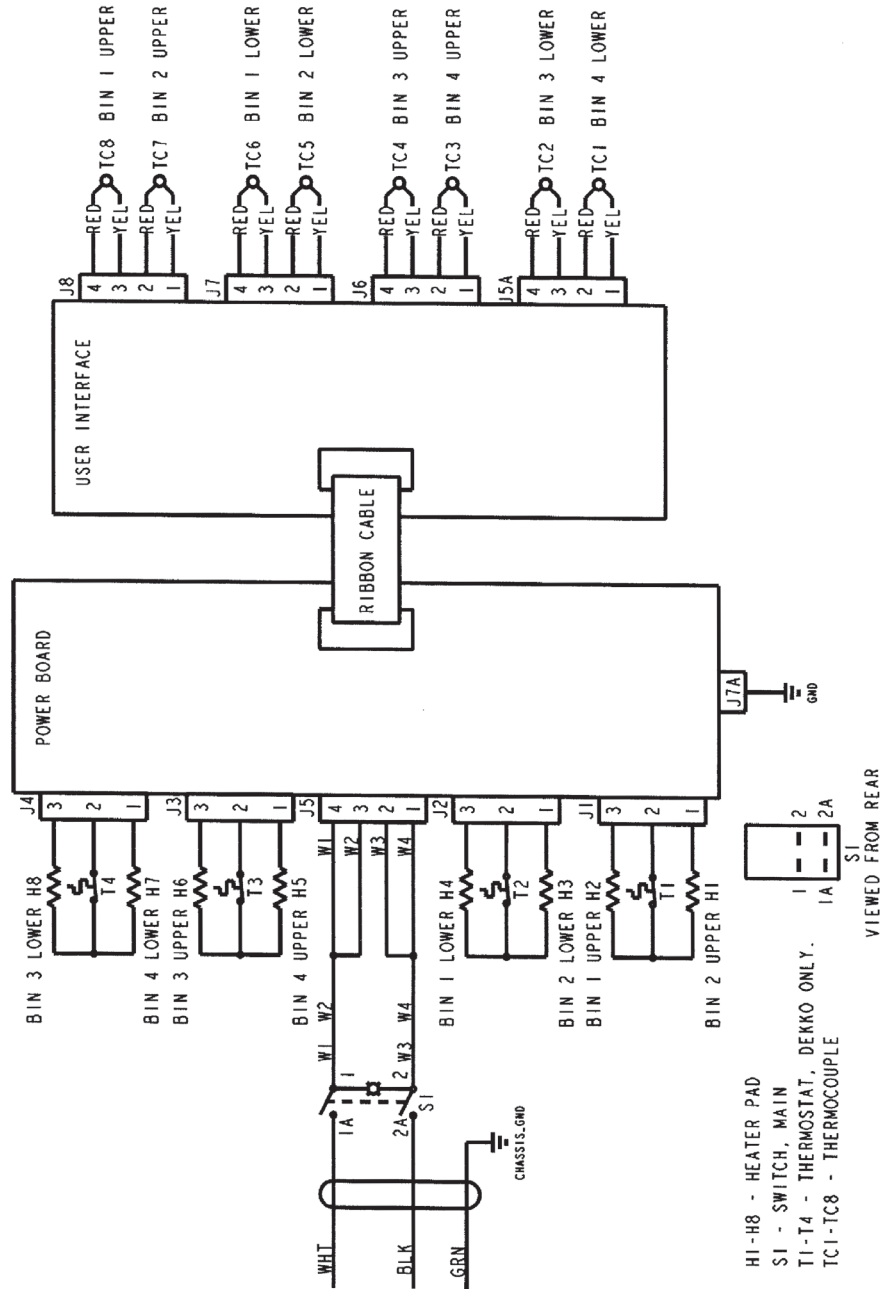

## Sequence Of Operation

Power Supply	Electrical power is supplied to the unit by a 3 conductor service for single phase. 120VAC Black conductor is hot. White conductor is neutral. Green and yellow conductor is ground. Power is permanently supplied to the main power switch.
Heating Circuit	Closing the main power switch supplies voltage to the power board and user interface. Temperature is set through the user interface which then intermittently supplies 120VAC to the heater plates. Temperature is then controlled by the thermocouples sending a reference signal back to the user interface.

# Replacement Parts

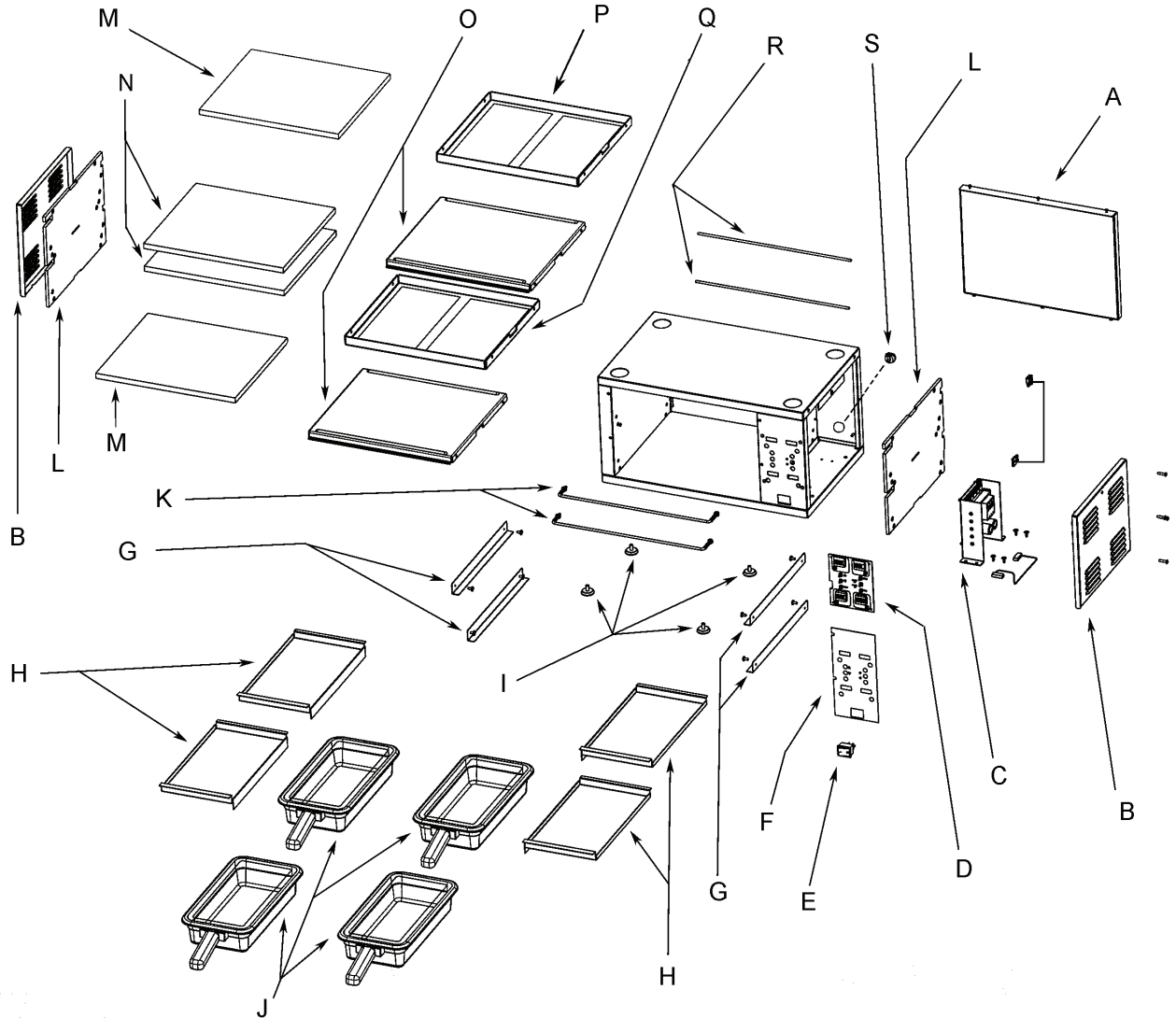

Key	Part Number	Part Description
A	MER340040	Back Panel Assembly
B	MER340041	Side Panel
C	MER340042	Power Board Assembly- 120V
	MER10000988-CE	Power Board Assembly- 230V
D	MER340043	Controller, User Interface
E	MER340038	Switch, Rocker, Lighted
F	MER10000949	Overlay, Control Panel
G	MER340045	Bracket, Heater Side
H	MER340020	Tray Seal
I	MER340011	Leg
J	MER340015	Tray, Plastic
K	MER340025	Tray Cover, Front Retention Rod, Assembly
L	MER10000968	Side Insulation
M	MER340048	Top / Bottom Insulation
N	MER10000966	Heater Insulation

Key	Part Number	Part Description
O	MER10000946-02	Lower Shelf Assembly-120V
	MER90001079	Lower Shelf Assembly-230V
P	MER340051	Upper Upper Shelf Assembly-120V
	MER90001078-01	Upper Upper Shelf Assembly-230V
Q	MER340052	Lower Upper Shelf Assembly-120V
	MER90001078-02	Lower Upper Shelf Assembly-230V
R	MER340053	Rod, Rear Tray Seal Retainer
S	MER000170-SP	Strain Relief
	MER340056	Cable (On/Off Switch to Power Board)
-	MER10001682	Pan Insert
-	MER340095	Power Cord, NEMA 5-15P
-	MER340097	Power Cord, Euro - 230V
-	MER340017	Retention Rod Spring
-	MER340014	Retention Rod Spring Clip
-	MER340055	Ribbon Cable (Power Board to Interface)

## Replacement Instructions

### Heat Shelf Replacement

1. Disconnect power.
2. Take out screws holding L Brackets in cavity.
3. Disconnect thermocouple and all power connections to board. Mark all wires for reassembly.
4. Take out power board.
5. Take out shelf mounting screws from both sides.
6. Remove shelves and feed wiring out of unit.



Be careful to avoid tearing the aluminum foil while working with wire connections.

7. Reassemble in reverse order.

### User Interface (U.I.) Board Replacement



When replacing U.I. board, be sure ribbon cable is connected so that blue wire is facing towards interior of unit.

1. Remove four (4) screws.
2. Disconnect thermocouples.
3. Disconnect ribbon cable.
4. Remove board.
5. Reassemble in reverse order.

## Notes

## Notes





*Thank you for choosing Merco!*

Help is a phone call away. Help our team of professional, courteous customer service reps by having your model number and serial number available at the time of your call (800) 733-8829.

Model: \_\_\_\_\_ S/N: \_\_\_\_\_

Installation Date: \_\_\_\_\_



For a list of Merco's authorized parts depots, visit our website at [www.mercoproducts.com](http://www.mercoproducts.com)

Register your Merco warranty online.  
Go to [www.mercoproducts.com](http://www.mercoproducts.com)  
under the service tab to complete.



980 S. Isabella Rd., Mt. Pleasant, MI 48858, U.S.A. • (989) 773-7981 or (800) 733-8829 • Fax (989) 773-3210 • [www.mercoproducts.com](http://www.mercoproducts.com)  
Merco reserves the right to make changes in design or specifications without prior notice. ©2014 Merco. All rights reserved. Printed in the U.S.A.

DMMOMHC22 02/14  
9291486