

SPLIT-TYPE AIR CONDITIONERS

INDOOR UNIT

Revision D:

- Specifications of MLZ-KP09/12/18NA-U1 and MLZ-KP09/12/18NA2-U1 have been corrected.

OBH802 REVISED EDITION-C is void.

**No. OBH802
REVISED EDITION-D**

SERVICE MANUAL

Models

MLZ-KP09NA - U1

MLZ-KP12NA - U1

MLZ-KP18NA - U1

MLZ-KP09NA2 - U1

MLZ-KP12NA2 - U1

MLZ-KP18NA2 - U1

**Outdoor unit service manual
MXZ-C*NA, MXZ-C*NAHZ Series
(OBH702, OCH573)**

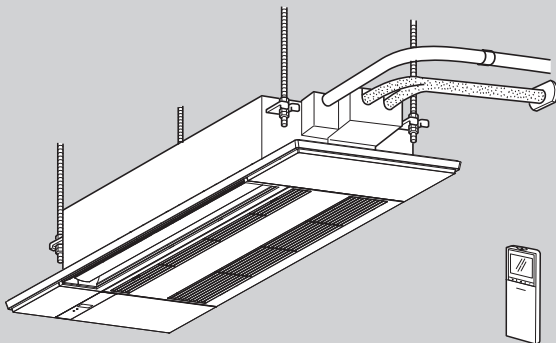

CONTENTS

1. TECHNICAL CHANGES	2
2. PART NAMES AND FUNCTIONS	3
3. SPECIFICATION	4
4. OUTLINES AND DIMENSIONS	6
5. WIRING DIAGRAM	7
6. REFRIGERANT SYSTEM DIAGRAM	9
7. SERVICE FUNCTIONS	10
8. MICROPROCESSOR CONTROL	13
9. TROUBLESHOOTING	22
10. DISASSEMBLY INSTRUCTIONS	37

PARTS CATALOG (OBB802)

Use the specified refrigerant only

Never use any refrigerant other than that specified.

Doing so may cause a burst, an explosion, or fire when the unit is being used, serviced, or disposed of.

Correct refrigerant is specified in the manuals and on the spec labels provided with our products.

We will not be held responsible for mechanical failure, system malfunction, unit breakdown or accidents caused by failure to follow the instructions.

<Preparation before the repair service>

- Prepare the proper tools.
- Prepare the proper protectors.
- Provide adequate ventilation.
- After stopping the operation of the air conditioner, turn off the power-supply breaker and pull the power plug.
- Discharge the capacitor before the work involving the electric parts.

<Precautions during the repair service>

- Do not perform the work involving the electric parts with wet hands.
- Do not pour water into the electric parts.
- Do not touch the refrigerant.
- Do not touch the hot or cold areas in the refrigeration cycle.
- When the repair or the inspection of the circuit needs to be done without turning off the power, exercise great caution not to touch the live parts.

WARNING

- When the refrigeration circuit has a leak, do not execute pump down with the compressor.
- When pumping down the refrigerant, stop the compressor before disconnecting the refrigerant pipes. The compressor may burst if air etc. get into it.
- When opening or closing the valve below freezing temperatures, refrigerant may spurt out from the gap between the valve stem and the valve body, resulting in injuries.

Revision A:

- 5. WIRING DIAGRAM has been modified.

Revision B:

- MLZ-KP09/12/18NA2-U1 have been added.

Revision C:

- Specifications of MLZ-KP09NA-U1 and MLZ-KP09NA2-U1 have been corrected.
- Some descriptions have been modified.

Revision D:

- Specifications of MLZ-KP09/12/18NA-U1 and MLZ-KP09/12/18NA2-U1 have been corrected.

1

TECHNICAL CHANGES

MLZ-KP09NA-U1

MLZ-KP12NA-U1

MLZ-KP18NA-U1

1. New model

MLZ-KP09NA-U1 → MLZ-KP09NA2-U1

MLZ-KP12NA-U1 → MLZ-KP12NA2-U1

MLZ-KP18NA-U1 → MLZ-KP18NA2-U1

1. Indoor electronic control P.C. board has been changed.

2

PART NAMES AND FUNCTIONS

INDOOR UNIT

MLZ-KP09NA MLZ-KP12NA MLZ-KP18NA
 MLZ-KP09NA2 MLZ-KP12NA2 MLZ-KP18NA2

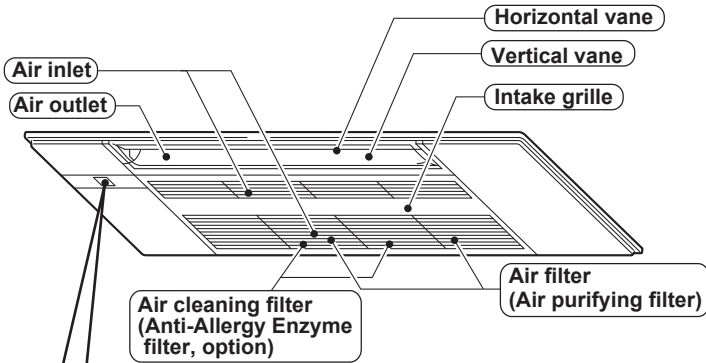

Display section

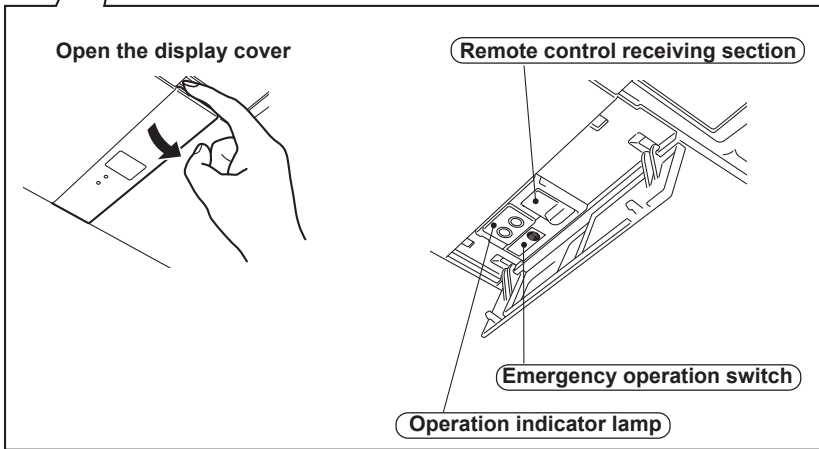
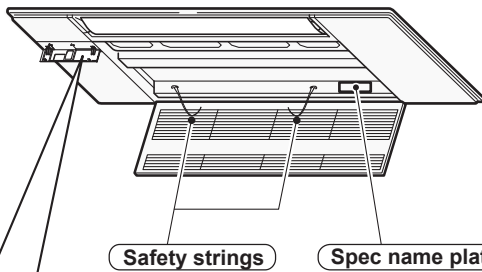

ACCESSORIES

	MODELS	MLZ-KP09NA	MLZ-KP12NA	MLZ-KP18NA
		MLZ-KP09NA2	MLZ-KP12NA2	MLZ-KP18NA2
①	Alkaline battery (AAA) for remote controller		2	
②	Drain hose (with insulation)		1	
③	Special washer (with cushion, 4pcs)		8	
④	Installation template		1	
⑤	Fixing screw for ④ M5 x 30 mm		4	
⑥	Band		1	
⑦	Fixing screw for ⑥ 4 x 16 mm		2	
⑧	Remote controller		1	
⑨	Remote controller holder		1	
⑩	Fixing screw for ⑨ 3.5 x 16 mm (Black)		2	

3

SPECIFICATION

1. Multi connection

Indoor model		MLZ-KP09NA MLZ-KP09NA2	MLZ-KP12NA MLZ-KP12NA2	MLZ-KP18NA MLZ-KP18NA2	
Power supply	V, phase, Hz	208/230, 1, 60			
Max. fuse size (time delay)/ Disconnect switch	A	15			
Airflow High - Med. - Low - SLow	COOL Dry (Wet)	CFM	311 - 282 - 254 - 212	332 - 297 - 258 - 212	403 - 346 - 293 - 212
	HEAT Dry	CFM	325 - 290 - 247 - 212	350 - 311 - 272 - 212	417 - 364 - 311 - 212
Sound level High - Med. - Low - SLow	Cooling	dB (A)	38 - 34 - 31 - 27	40 - 36 - 32 - 27	47 - 41 - 36 - 29
	Heating	dB (A)	37 - 34 - 29 - 26	40 - 36 - 32 - 26	48 - 42 - 37 - 26
Cond. drain connection O.D.	in.	Ø1 (26 mm)			
Dimensions	W	43-3/8			
	D	in.	14-3/16		
	H	7-5/16			
Weight	lb.	34			
External finish	White				
Control voltage (by built-in transformer)	12 - 24 V DC				

NOTE: Test conditions are based on ARI 210/240.

Specifications and rated conditions of main electric parts

Item	Model	MLZ-KP09NA	MLZ-KP12NA	MLZ-KP18NA
		MLZ-KP09NA2	MLZ-KP12NA2	MLZ-KP18NA2
Fuse	(F11)	T3.15AL250V		
Horizontal vane motor	(MV1)	12 V DC		
Vertical vane motor	(MV2)	12 V DC		
Varistor	(NR11)	470 V		
DRAIN PUMP	(DP)	230 V 6.4 W		
FLOAT SENSOR	(FS)	5 V DC		

3-1. OPERATING RANGE

(1) POWER SUPPLY

	Rated voltage	Guaranteed voltage (V)
Indoor unit	208/230 V 1 phase 60 Hz	Min. 187 208 230 Max. 253 ----- ----- ----- -----

(2) OPERATION

*The operating range of the outdoor unit depends on the connected outdoor unit.

Mode	Condition	Intake air temperature (°F)			
		Indoor		Outdoor	
		DB	WB	DB	WB
Cooling	Standard temperature	80	67	95	—
	Maximum temperature	90	73	115	—
	Minimum temperature	67	57	14	—
	Maximum humidity	78%		—	
Heating	Standard temperature	70	60	47	43
	Maximum temperature	80	67	75	65
	Minimum temperature	70	60	-13	-14

3-2. OUTLET AIR SPEED AND COVERAGE

Multi connection

Model	Mode	Function	Airflow (CFM)	Air speed (ft./s.)	Coverage (ft.)
MLZ-KP09NA MLZ-KP09NA2	HEAT	Dry	325	13.6	21.7
	COOL	Dry	311	13.0	20.7
		Wet	—	—	—
MLZ-KP12NA MLZ-KP12NA2	HEAT	Dry	350	14.6	23.3
	COOL	Dry	332	13.9	22.1
			Wet	—	—
MLZ-KP18NA MLZ-KP18NA2	HEAT	Dry	417	17.5	27.6
	COOL	Dry	403	16.9	26.7
			Wet	—	—

- The air coverage is the figure up to the position where the air speed is 1 ft./s., when air is blown out horizontally from the unit properly at the High speed position. The coverage should be used only as a general guideline since it varies according to the size of the room and furniture arranged inside the room.

MLZ-KP09NA MLZ-KP12NA MLZ-KP18NA
MLZ-KP09NA2 MLZ-KP12NA2 MLZ-KP18NA2

Unit: inch

INDOOR UNIT

INDOOR UNIT OUTLINE DRAWING

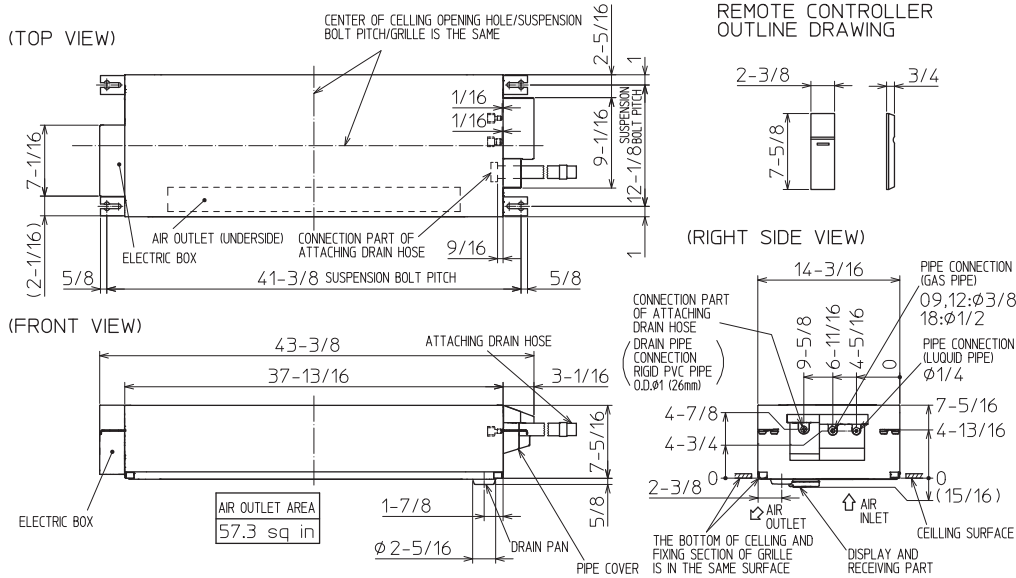

GRILLE OUTLINE DRAWING (MLP-444W)

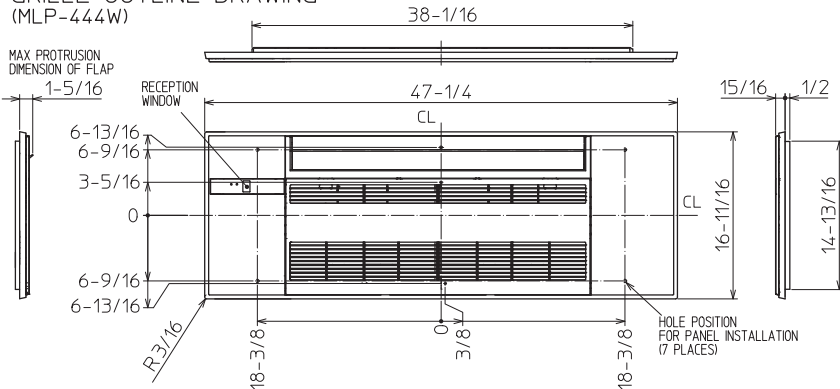

		KP09/12NA	KP18NA
EXTENSION PIPE	LIQUID PIPE O.D.	ø1/4	
	GAS PIPE O.D.	ø3/8	ø1/2
CONNECTING OF PIPE	LIQUID PIPE	FLARED CONNECTION ø1/4	
	GAS PIPE	FLARED CONNECTION ø3/8	FLARED CONNECTION ø1/2
DRAIN HOSE	HEAT INSULATOR O.D.	ø1	EFFECTIVE LENGTH 18-7/8
DRAIN PIPE CONNECTION	RIGID PVC PIPE O.D. ø1 (26mm)		

NOTE1. CUT THE DRAIN HOSE (ACCESSORY) FOR USE, IF NECESSARY.

INDOOR UNIT DETAIL VIEW (TOP VIEW)

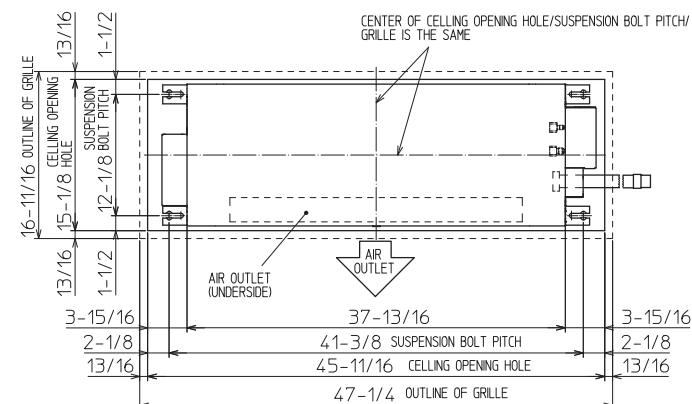

THE METHOD FOR STANDING DRAIN FROM INDOOR UNIT
 ※ CUT THE DRAIN HOSE (ACCESSORY) FOR USE, IF NECESSARY.

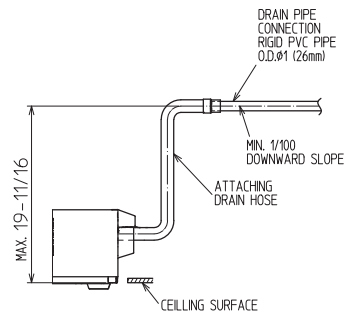

5

WIRING DIAGRAM

INDOOR UNIT

MLZ-KP09NA- U1

MLZ-KP12NA- U1

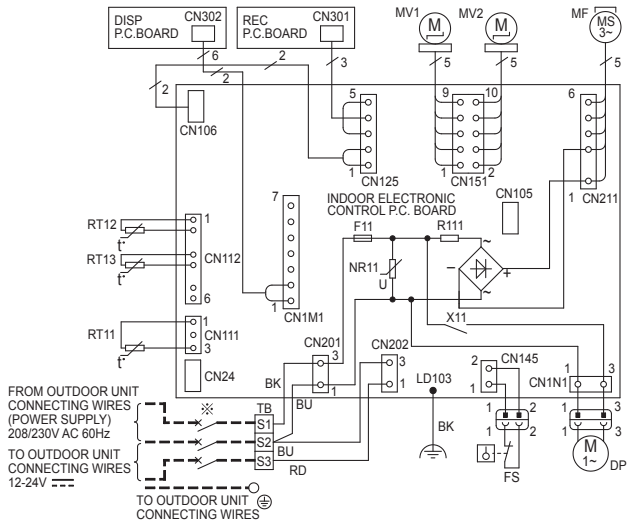

SYMBOL	NAME	SYMBOL	NAME
MF	FAN MOTOR	RT11	ROOM TEMP. THERMISTOR
MV1	HORIZONTAL VANE MOTOR	RT12	COIL TEMP. THERMISTOR(MAIN)
MV2	VERTICAL VANE MOTOR	RT13	COIL TEMP. THERMISTOR(SUB)
DP	DRAIN PUMP	NR11	VARISTOR
FS	FLOAT SENSOR	R111	RESISTOR
F11	FUSE (T3.15AL250V)		
X11	RELAY		
TB	TERMINAL BLOCK		

- NOTES :
- About the outdoor side electric wiring refer to the outdoor unit electric wiring diagram for servicing.
 - Use copper conductors only. (For field wiring)
 - Symbols below indicate.

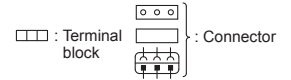

- REMARQUES :
- Pour le câblage électronique côté extérieur, se reporter au schéma d'entretien du câblage électronique de l'appareil extérieur.
 - Utiliser des fils d'alimentation en cuivre.
 - Les symboles ont les significations suivantes

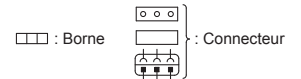

- * A disconnect should be required by local code.
- * Se procurer un sectionneur conforme aux réglementations locales.

MLZ-KP09NA2- U1

MLZ-KP12NA2- U1

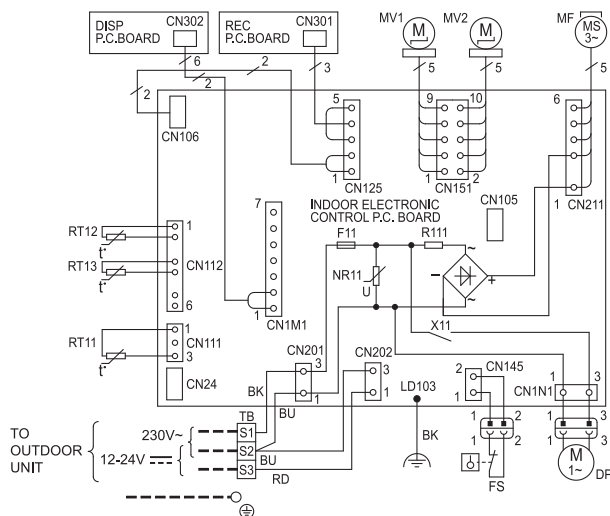

SYMBOL	NAME	SYMBOL	NAME
MF	FAN MOTOR	RT11	ROOM TEMP. THERMISTOR
MV1	HORIZONTAL VANE MOTOR	RT12	COIL TEMP. THERMISTOR(MAIN)
MV2	VERTICAL VANE MOTOR	RT13	COIL TEMP. THERMISTOR(SUB)
DP	DRAIN PUMP	NR11	VARISTOR
FS	FLOAT SENSOR	R111	RESISTOR
F11	FUSE (T3.15AL250V)		
X11	RELAY		
TB	TERMINAL BLOCK		

- NOTES :
- About the outdoor side electric wiring refer to the outdoor unit electric wiring diagram for servicing.
 - Use copper conductors only. (For field wiring)
 - Symbols below indicate.



- REMARQUES :
- Pour le câblage électronique côté extérieur, se reporter au schéma d'entretien du câblage électronique de l'appareil extérieur.
 - Utiliser des fils d'alimentation en cuivre.
 - Les symboles ont les significations suivantes

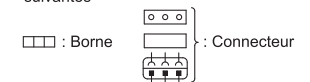

- * A disconnect should be required by local code.
- * Se procurer un sectionneur conforme aux réglementations locales.

MLZ-KP18NA- U1

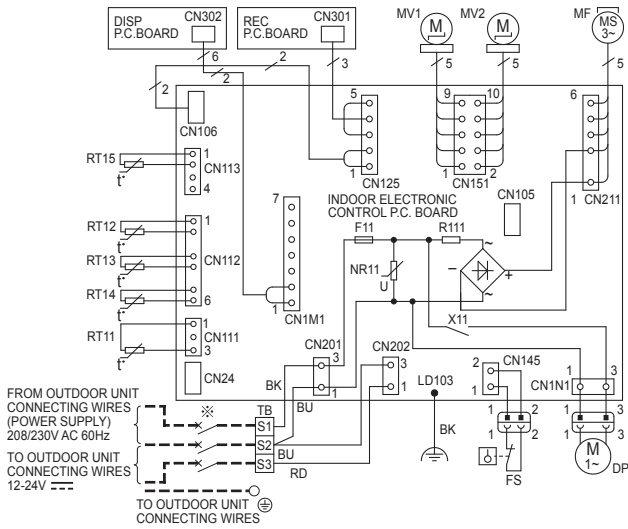

SYMBOL	NAME	SYMBOL	NAME
MF	FAN MOTOR	RT11	ROOM TEMP. THERMISTOR
MV1	HORIZONTAL VANE MOTOR	RT12	COIL TEMP. THERMISTOR(MAIN1)
MV2	VERTICAL VANE MOTOR	RT13	COIL TEMP. THERMISTOR(SUB)
DP	DRAIN PUMP	RT14	COIL TEMP. THERMISTOR(MAIN2)
FS	FLOAT SENSOR	RT15	COIL TEMP. THERMISTOR(MAIN3)
F11	FUSE (T3.15AL250V)	NR11	VARISTOR
X11	RELAY	R111	RESISTOR
TB	TERMINAL BLOCK		

※ A disconnect should be required by local code.
 ※ Se procurer un sectionneur conforme aux réglementations locales.

NOTES :

- About the outdoor side electric wiring refer to the outdoor unit electric wiring diagram for servicing.
- Use copper conductors only. (For field wiring)
- Symbols below indicate.

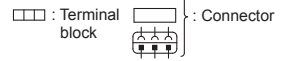

REMARQUES :

- Pour le câblage électronique côté extérieur, se reporter au schéma d'entretien du câblage électronique de l'appareil extérieur.
- Utiliser des fils d'alimentation en cuivre.
- Les symboles ont les significations suivantes

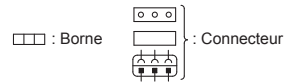

MLZ-KP18NA2- U1

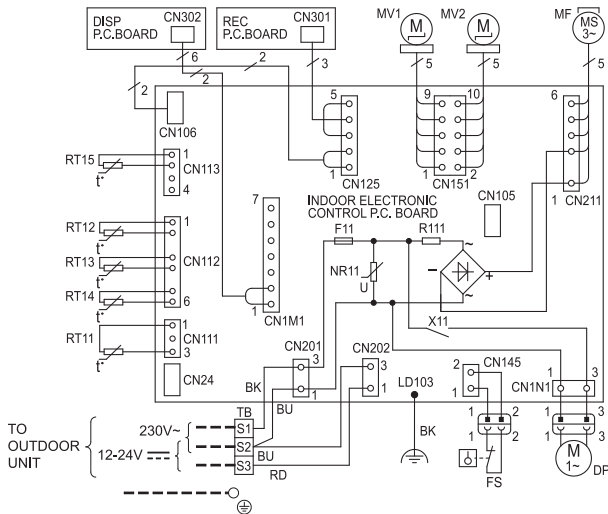

SYMBOL	NAME	SYMBOL	NAME
MF	FAN MOTOR	RT11	ROOM TEMP. THERMISTOR
MV1	HORIZONTAL VANE MOTOR	RT12	COIL TEMP. THERMISTOR(MAIN1)
MV2	VERTICAL VANE MOTOR	RT13	COIL TEMP. THERMISTOR(SUB)
DP	DRAIN PUMP	RT14	COIL TEMP. THERMISTOR(MAIN2)
FS	FLOAT SENSOR	RT15	COIL TEMP. THERMISTOR(MAIN3)
F11	FUSE (T3.15AL250V)	NR11	VARISTOR
X11	RELAY	R111	RESISTOR
TB	TERMINAL BLOCK		

* A disconnect should be required by local code.
 * Se procurer un sectionneur conforme aux réglementations locales.

NOTES :

- About the outdoor side electric wiring refer to the outdoor unit electric wiring diagram for servicing.
- Use copper conductors only. (For field wiring)
- Symbols below indicate.

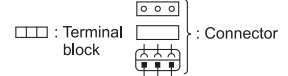

REMARQUES :

- Pour le câblage électronique côté extérieur, se reporter au schéma d'entretien du câblage électronique de l'appareil extérieur.
- Utiliser des fils d'alimentation en cuivre.
- Les symboles ont les significations suivantes

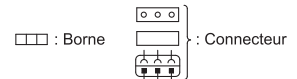

6

REFRIGERANT SYSTEM DIAGRAM

INDOOR UNIT

**MLZ-KP09NA
MLZ-KP12NA
MLZ-KP09NA2
MLZ-KP12NA2**

**MLZ-KP18NA
MLZ-KP18NA2**

Unit: inch(mm)

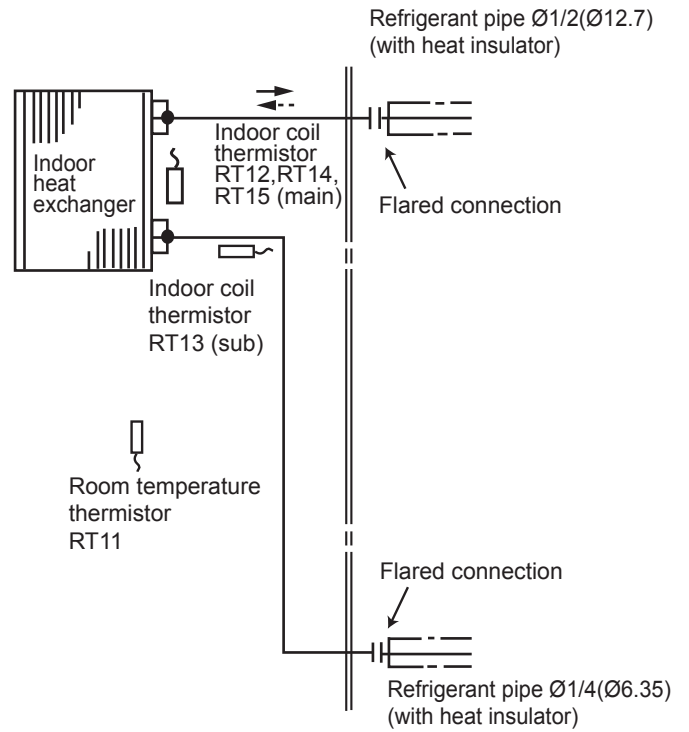
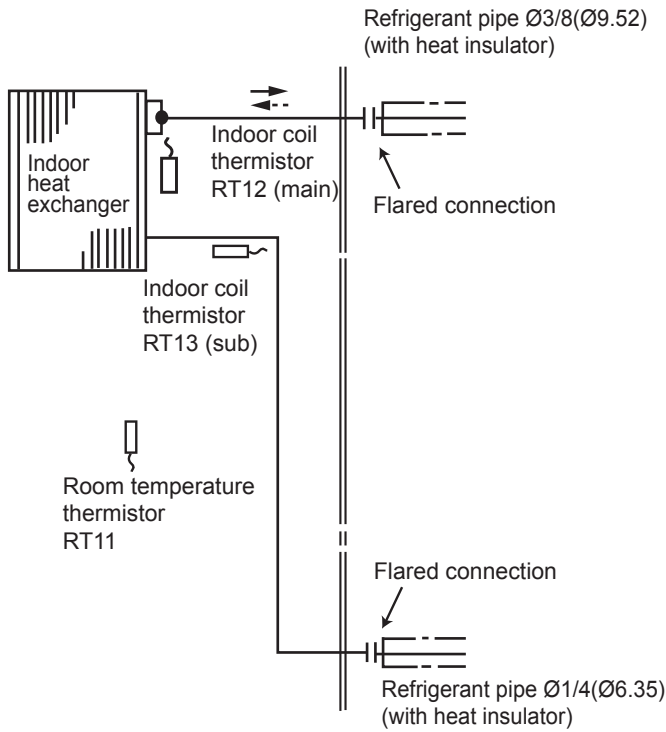

→ Refrigerant flow in cooling
 - - - → Refrigerant flow in heating

MLZ-KP09NA MLZ-KP12NA MLZ-KP18NA
MLZ-KP09NA2 MLZ-KP12NA2 MLZ-KP18NA2

7-1. TIMER SHORT MODE

- For service, the following set time can be shortened by bridging the timer short mode point on the electronic control P.C. board. (Refer to 9-7.)
- The set time for the ON/OFF timer can be reduced to 1 second for each minute.
- After the breaker is turned on, the time for starting the compressor, which normally takes 3 minutes, can be reduced to 3 seconds. Restarting the compressor, which takes 3 minutes, cannot be reduced.

7-2. HOW TO SET REMOTE CONTROLLER EXCLUSIVELY FOR A PARTICULAR INDOOR UNIT

A maximum of 4 indoor units with wireless remote controllers can be used in a room.

To operate the indoor units individually with each remote controller, assign a number to each remote controller according to the number of the indoor unit.

This setting can be set only when all the following conditions are met:

- The remote controller is powered OFF.
- Weekly timer is not set.
- Weekly timer is not being edited.

1. How to modify the electronic control P.C. board

Turn OFF the power supply before modification. To assign a number to each indoor unit, cut off "JR05" and "JR06" on the electronic control P.C. board as shown in Table 1. (Refer to 9-7.)

Table 1

	JR05	JR06
Unit No. 1	No modification	No modification
Unit No. 2	Cut off JR05	No modification
Unit No. 3	No modification	Cut off JR06
Unit No. 4	Cut off JR05	Cut off JR06

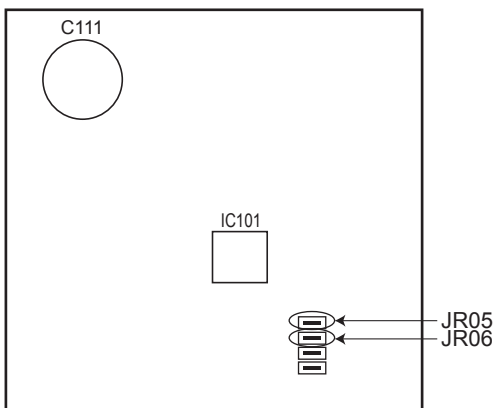

2. How to set the remote controller

- (1) Hold down [1~4] button on the remote controller for 2 seconds to enter the pairing mode.
- (2) Press [1~4] button again and assign a number to each remote controller.
Each press of [1~4] button advances the number in the following order: 1 → 2 → 3 → 4.
- (3) Press  button to complete the pairing setting.

After the setting, turn ON the power supply and with the remote controller headed towards the indoor unit, press the STOP/OPERATE (OFF/ON) button. If 1 or 2 beeps is heard from the indoor unit, the setting is completed correctly. The remote controller that first sends a signal to an indoor unit will be regarded as the remote controller for the indoor unit.

Once they are set, the indoor unit will only receive the signal from the assigned remote controller afterwards.

7-3. AUTO RESTART FUNCTION

When the indoor unit is controlled with the remote controller, the operation mode, the set temperature, and the fan speed are memorized by the indoor electronic control P.C. board. "AUTO RESTART FUNCTION" automatically starts operation in the same mode just before the shutoff of the main power.

Operation

- ① If the main power has been cut, the operation settings remain.
- ② After the power is restored, the unit restarts automatically according to the memory.
(However, it takes at least 3 minutes for the compressor to start running.)

How to disable "AUTO RESTART FUNCTION"

- ① Turn off the main power for the unit.
- ② Cut the jumper wire to JR77 on the indoor electronic control P.C. board. (Refer to 9-7.)

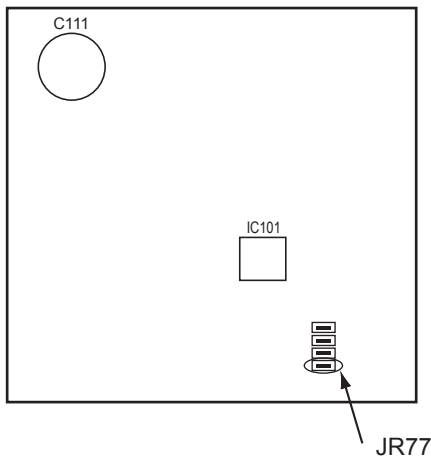

NOTE:

- The operation settings are memorized when 10 seconds has passed after the indoor unit was operated with the remote controller.
- If main power is turned OFF or a power failure occurs while AUTO START/STOP timer is active, the timer setting is cancelled.
- If the unit has been off with the remote controller before power failure, the auto restart function does not work as the power button of the remote controller is off.
- To prevent breaker tripping due to the rush of starting current, systematize other home appliance not to turn on at the same time.
- When some air conditioners are connected to the same supply system, if they are operated before power failure, the starting current of all the compressors may flow simultaneously at restart. Therefore, the special counter-measures are required to prevent the main voltage-drop or the rush of the starting current by adding to the system that allows the units to start one by one.

7-4. P.C. BOARD MODIFICATION FOR CHANGING AIRFLOW VOLUME

Change Slide switch SW3 setting according to the height of ceiling.

Slide switch SW3	Normal	Increase airflow volume
Ceiling height	8.0 ft. (2.4 m) or below	above 8.0 ft. (2.4 m) and 9.0 ft. (2.7 m) or below

NOTE: When the ceiling is above 9.0 ft. (2.7 m), airflow volume may be insufficient even with the Slide switch (SW3) set to "increase airflow".

How to change Slide switch (SW3) setting (Factory setting is normal)

1. Make sure that the breaker for air conditioner is turned OFF.
2. Remove the electrical cover (1) and (2) of the indoor unit.
3. Slide out the electronic control P.C. board, and switch up the Slide switch (SW3).
4. Put the electronic control P.C. board back to the original position, and install the electrical cover (1) and (2).

NOTE:

- Install the indoor unit at least 7.2 ft. (2.2 m) above floor or grade level.
- Perform static elimination before setting.

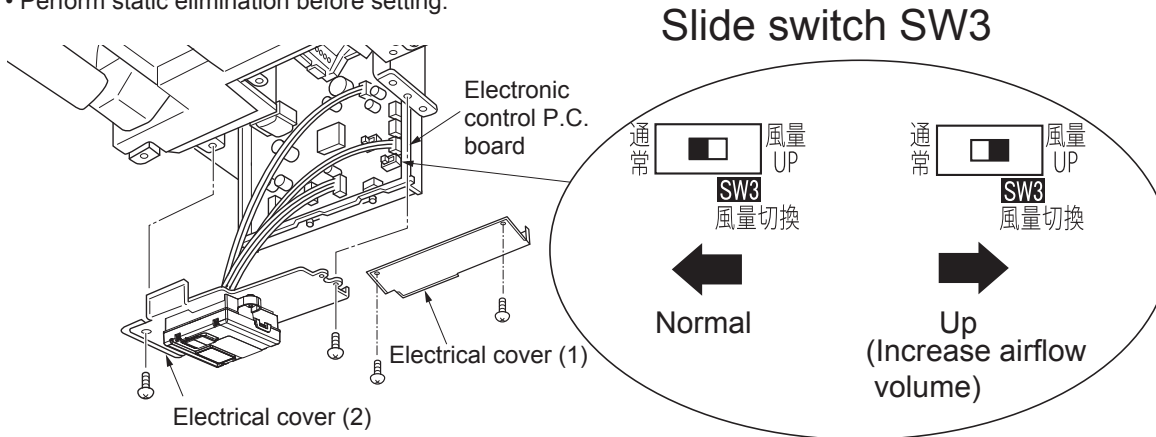

7-5. P.C. BOARD MODIFICATION FOR CHANGING AIRFLOW DIRECTION ADJUSTMENT

The setting when the higher airflow is preferred in the Airflow direction (1)

The angle of airflow direction (1) can be slightly heightened by changing SWV1 to up. However, it may cause the dirt on the ceiling.

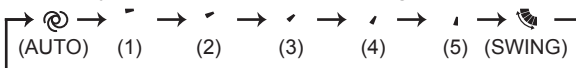

How to change Slide switch (SWV1) setting (Factory setting is normal)

1. Make sure that the breaker for air conditioner is turned OFF.
2. Remove the electrical cover (1) and (2) of the indoor unit.
3. Slide out the electronic control P.C. board, and change the slide switch (SWV1) to up.
4. Put the electronic control P.C. board back to the original position, and install the electrical cover (1) and (2).

NOTE:

- Perform static elimination before setting.

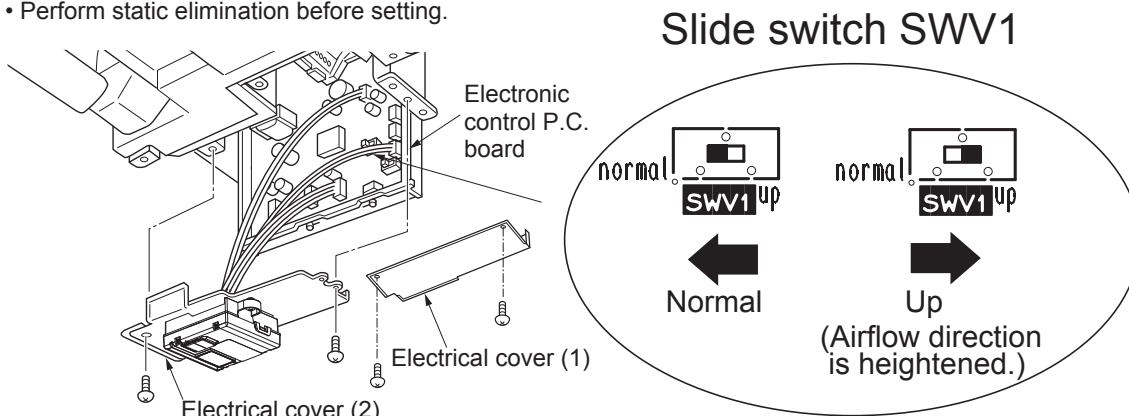

MLZ-KP09NA MLZ-KP12NA MLZ-KP18NA
 MLZ-KP09NA2 MLZ-KP12NA2 MLZ-KP18NA2

WIRELESS REMOTE CONTROLLER

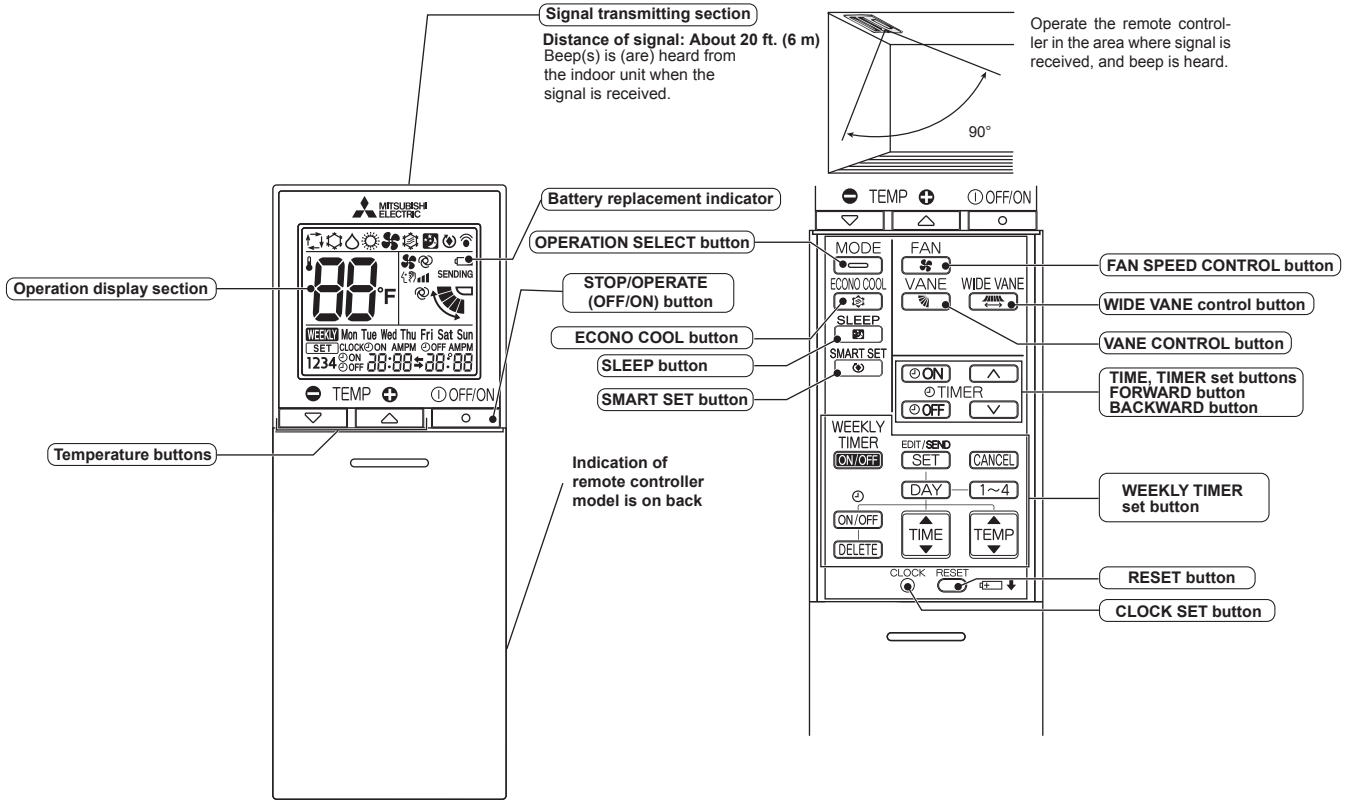

NOTE: Last setting will be stored after the unit is turned OFF with the remote controller. Indoor unit receives the signal of the remote controller with beeps.

INDOOR UNIT DISPLAY SECTION

Operation Indicator lamp

The operation indicator at the right side of the indoor unit indicates the operation state.

•The following indication applies regardless of shape of the indication.

Indication	Operation state	Room temperature
● ●	The unit is operating to reach the set temperature	About 4°F(2°C) or more away from set temperature
● ○	The room temperature is approaching the set temperature	About 2 to 4°F(1 to 2°C) from set temperature
● ☉	Standby mode (Refer to multi system operation)	—

● Lit
 ☉ Blinking
 ○ Not lit

8-1. COOL (❄️) OPERATION

- (1) Press STOP/OPERATE(OFF/ON) button.
OPERATION INDICATOR lamp of the indoor unit turns on with a beep tone.
- (2) Select COOL mode with OPERATION SELECT button.
- (3) Press TEMPERATURE buttons TEMP \ominus or \oplus button to select the desired temperature. The setting range is 61 - 88°F (16 - 31°C).

1. Coil frost prevention

The compressor operational frequency is controlled by the temperature of the indoor heat exchanger to prevent the coil from frosting.

When the temperature of indoor heat exchanger becomes too low, the coil frost prevention mode works.

The indoor fan operates at the set speed and the compressor stops. This mode continues until the temperature of indoor heat exchanger rises.

NOTE: Do not operate COOL mode at low outside temperature [less than 14°F (-10°C)]. Water condensed in the unit may drip and wet or damage furniture, etc.

8-2. DRY (☁️) OPERATION

- (1) Press STOP/OPERATE(OFF/ON) button.
OPERATION INDICATOR lamp of the indoor unit turns on with a beep tone.
- (2) Select DRY mode with OPERATION SELECT button.
- (3) The set temperature is determined from the initial room temperature.

1. Coil frost prevention

Coil frost prevention works the same way as that in COOL mode. (8-1.1.)

8-3. FAN (🌀) OPERATION

- (1) OPERATION INDICATOR lamp of the indoor unit turns on with a beep tone.
- (2) Select FAN mode with OPERATION SELECT button.
- (3) Select the desired fan speed. When AUTO, it becomes Low.
Only indoor fan operates.
Outdoor unit does not operate.

8-4. HEAT (🔥) OPERATION

- (1) Press STOP/OPERATE(OFF/ON) button.
OPERATION INDICATOR lamp of the indoor unit turns on with a beep tone.
- (2) Select HEAT mode with OPERATION SELECT button.
- (3) Press TEMPERATURE buttons TEMP \ominus or \oplus button to select the desired temperature. The setting range is 50°F(10°C) and 61 - 88°F (16 - 31°C).

1. Cold air prevention control

When the compressor is not operating or is starting, and the temperature of indoor heat exchanger and/or the room temperature is low or when defrosting is being done, the indoor fan will stop or rotate in Very Low speed.

2. Defrosting

Defrosting starts when the temperature of outdoor heat exchanger becomes too low.

The compressor stops once, the indoor/outdoor fans stop, the 4-way valve reverses, and the compressor re-starts.

This mode continues until the temperature of outdoor heat exchanger rises or the fixed time passes.

8-5. AUTO CHANGE OVER ... AUTO MODE OPERATION

Once desired temperature is set, unit operation is switched automatically between COOL and HEAT operation.

Mode selection

(1) Initial mode

When unit starts the operation with AUTO operation from OFF:

- If the room temperature is higher than the set temperature, operation starts in COOL mode.
- If the room temperature is equal to or lower than the set temperature, operation starts in HEAT mode.

(2) Mode change

COOL mode changes to HEAT mode when about 15 minutes have passed with the room temperature 4°F (2°C) below the set temperature.

HEAT mode changes to COOL mode when about 15 minutes have passed with the room temperature 4°F (2°C) above the set temperature.

NOTE 1

If 2 or more indoor units are operating in multi system, there might be a case that the indoor unit, which is operating in \square (AUTO), cannot change over to the other operating mode (COOL ↔ HEAT) and becomes a state of standby.

Refer to **NOTE 2 "FOR MULTI SYSTEM AIR CONDITIONER"**.

NOTE 2
FOR MULTI SYSTEM AIR CONDITIONER
OUTDOOR UNIT: MXZ series

Multi system air conditioner can connect 2 or more indoor units with one outdoor unit.

- When you try to operate 2 or more indoor units with one outdoor unit simultaneously, one for the cooling and the others for heating, the operation mode of the indoor unit that operates first is selected. Other indoor units cannot operate, and operation indicator lamp blinks as shown in the figure below. In this case, please set all the indoor units to the same operation mode.

OPERATION INDICATOR

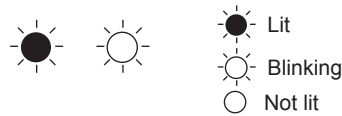

- When indoor unit starts the operation while the defrosting of outdoor unit is being done, it takes a few minutes (max. 10 minutes) to blow out the warm air.
- In the heating operation, though indoor unit that does not operate may get warm or the sound of refrigerant flowing may be heard, they are not malfunction. The reason is that the refrigerant continuously flows into it.

8-6. AUTO VANE OPERATION

1. Horizontal vane

(1) Vane motor drive

These models are equipped with a stepping motor for the horizontal vane. The rotating direction, speed, and angle of the motor are controlled by pulse signals (approximately 12 V) transmitted from indoor microprocessor.

(2) The horizontal vane angle and mode change as follows by pressing VANE CONTROL button.

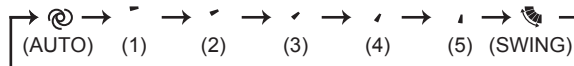

NOTE: The setting when the higher airflow is preferred in the Airflow direction (1)
 The angle of airflow direction (1) can be slightly heightened by changing SWV1 to up.
 (Refer to 7-5. P.C. BOARD MODIFICATION FOR CHANGING AIRFLOW DIRECTION ADJUSTMENT.)
 However, it may cause the dirt on the ceiling.

Factory setting is normal.

(3) Positioning

To confirm the standard position, the vane moves until it touches the vane stopper. Then the vane is set to the selected angle.

Confirming of standard position is performed in the following cases:

- (a) When the power supply turns on.
- (b) When the operation starts or finishes (including timer operation).
- (c) When the test run starts.
- (d) When multi-standby starts or finishes.
- (e) When the swing operation finishes.

(4) VANE AUTO (⊙) mode

In VANE AUTO mode, the microprocessor automatically determines the vane angle and operation to make the optimum room-temperature distribution.

(1) In COOL and DRY operation Vane angle is fixed to Angle 1.

(2) In HEAT operation Vane angle is fixed to Angle 4.

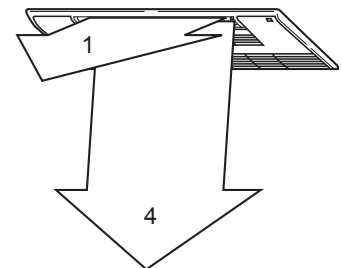

(5) STOP (operation OFF) and ON TIMER standby

In the following cases, the horizontal vane returns to the closed position.

- (a) When STOP/OPERATE(OFF/ON) button is pressed (POWER OFF).
- (b) When the operation is stopped by the emergency operation.
- (c) When ON TIMER is ON standby.

(6) SWING (🌀) mode

By selecting SWING mode with VANE CONTROL button, the horizontal vanes swing vertically.
When COOL, DRY or FAN mode is selected, only the upper vane swings.

(7) Cold air prevention in HEAT operation

The horizontal vane position is set to Upward.

(8) ECONO COOL (🌀) operation (ECONOMical operation)

When ECONO COOL button is pressed in COOL mode, set temperature is automatically set 4°F(2°C) higher by microprocessor. However, the temperature on the LCD screen on the remote controller is not changed.

Also the horizontal vane swings in various cycle.

SWING operation makes you feel cooler than set temperature. So, even though the set temperature is higher, the air conditioner can keep comfort. As a result, energy can be saved.

To cancel this operation, select a different mode or press one of the following buttons in ECONO COOL operation: ECONO COOL, WIDE VANE CONTROL or VANE CONTROL button.

2. Vertical vane

(1) Press WIDE VANE CONTROL button to change horizontal airflow direction.

•The vertical vane moves for about 30 seconds.

(After 30 seconds, the vertical vane moves to its original position. In this case, press WIDE VANE CONTROL button again.)

(2) Press WIDE VANE CONTROL button again to set horizontal airflow direction.

•The vertical vane stops and the airflow direction is set.

(3) Positioning

To confirm the standard position, the vane moves until it touches the vane stopper. Then the vane set to the desired angle.

Confirming of standard position is performed in the following cases:

(a) When STOP/OPERATE(OFF/ON) button is pressed (POWER ON).

(b) When SWING is started.

8-7. DRAIN PUMP/ FLOAT SENSOR CONTROL

1. Drain pump

Operating condition:

1. During COOL, DRY, or emergency COOL operation
2. When float sensor detects water level above fixed point during:
 - (a) HEAT operation.
 - (b) emergency HEAT operation.
 - (c) standby when during multi system operation.
 - (d) standby when ON timer is set.
 - (e) operation STOP.

Drain pump operates in conditions 1 or 2.

Operation stop condition:

Condition other than 1 or 2 indicated above.

2. Float sensor

Float moves with the up and down of water surface inside the drain pan, and judges water level.

(Fixed point differs at raised and lowered water levels.)

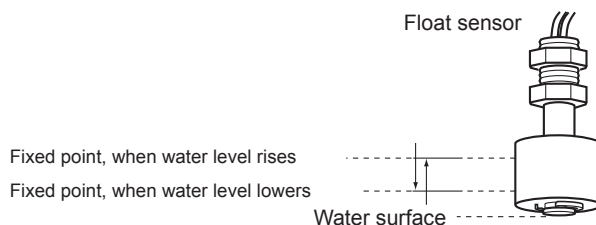

8-8. TIMER OPERATION

1. How to set the time

- (1) Check that the current time is set correctly.

NOTE: Timer operation will not work without setting the current time. Initially "0:00" blinks at the current time display of TIME MONITOR, so set the current time correctly with CLOCK SET button.

How to set the current time

- (a) Press the CLOCK set button.
(b) Press the TIME SET buttons (▲) and (▼) to set the current time.
- Each time FORWARD button (▲) is pressed, the set time increases by 1 minute, and each time BACKWARD button (▼) is pressed, the set time decreases by 1 minute.
 - Pressing those buttons longer, the set time increases/decreases by 10 minutes.
- (c) Press the CLOCK set button.
(2) Press STOP/OPERATE(OFF/ON) button to start the air conditioner.
(3) Set the time of timer.

ON timer setting

- (a) Press ON TIMER button (⊙ON) during operation.
(b) Set the time of the timer using TIME SET buttons (▲) and (▼). *

OFF timer setting

- (a) Press OFF TIMER button (⊙OFF) during operation.
(b) Set the time of the timer using TIME SET buttons (▲) and (▼). *
- * Each time FORWARD button (▲) is pressed, the set time increases by 10 minutes: each time BACKWARD button (▼) is pressed, the set time decreases by 10 minutes.

2. To release the timer

To release ON timer, press ON TIMER button (⊙ON).

To release OFF timer, press OFF TIMER button (⊙OFF).

TIMER is cancelled and the display of set time disappears.

PROGRAM TIMER

- OFF timer and ON timer can be used in combination. The set time that is reached first will operate first.
- "←" and "→" display shows the order of OFF timer and ON timer operation.

(Example 1) The current time is 8:00 PM.

The unit turns off at 11:00 PM, and on at 6:00 AM.

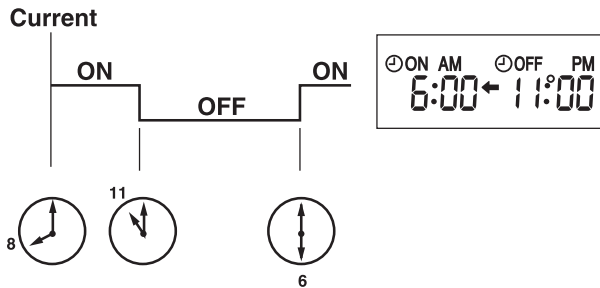

(Example 2) The current time is 11:00 AM.

The unit turns on at 5:00 PM, and off at 9:00 PM.

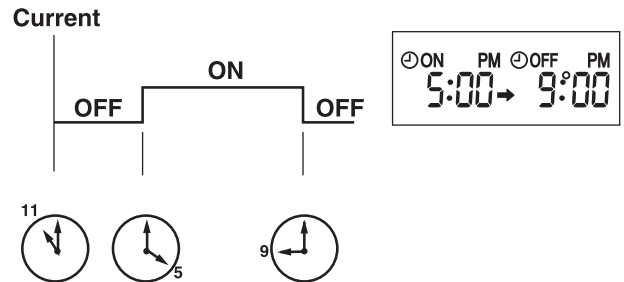

NOTE: If the main power is turned OFF or a power failure occurs while ON/OFF timer is active, the timer setting is cancelled. As these models are equipped with an auto restart function, the air conditioner starts operating with timer cancelled when power is restored.

8-9. WEEKLY TIMER OPERATION

- A maximum of 4 ON or OFF timers can be set for individual days of the week.
- A maximum of 28 ON or OFF timers can be set for a week.

E.g. : Runs at 75°F (24°C) from waking up to leaving home, and runs at 81°F (27°C) from getting home to going to bed on weekdays.
Runs at 81°F (27°C) from waking up late to going bed early on weekends.

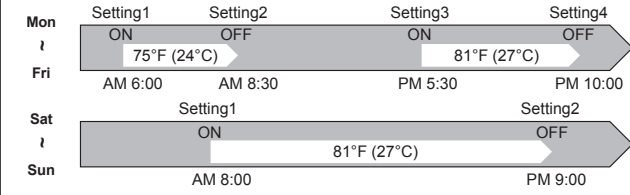

NOTE:

- The simple ON/OFF timer setting is available while the weekly timer is on. In this case, the ON/OFF timer has priority over the weekly timer; the weekly timer operation will start again after the simple ON/OFF timer is complete.
- When the weekly timer is set, temperature cannot be set to 50°F(10°C).
- The weekly timer operation and SMART SET operation cannot be used together.

1. How to set the weekly timer

* Make sure that the current time and day are set correctly.

- (1) Press **EDIT/SEND** button to enter the weekly timer setting mode.

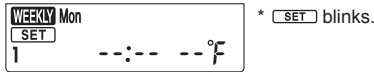

- (2) Press **DAY** and **1~4** buttons to select setting days and/or numbers.

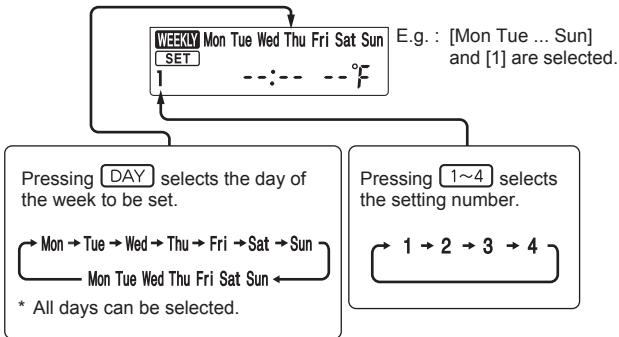

- (3) Press **ON/OFF**, **TIME**, and **TEMP** buttons to set ON/OFF, time, and temperature.

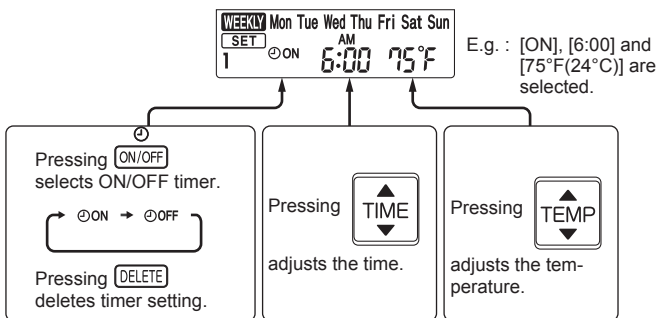

* Hold down the button to change the time quickly.

* The temperature can be set between 61°F and 88°F (16°C and 31°C) at weekly timer.





Press **DAY** and **1~4** buttons to continue setting the timer for other days and/or numbers.



(4) Press  button to complete and transmit the weekly timer setting.





*  which was blinking goes out, and the current time will be displayed.

NOTE:

- Press  button to transmit the setting information of weekly timer to the indoor unit. Point the remote controller toward the indoor unit for 3 seconds.
- When setting the timer for more than one day of the week or one number,  button does not have to be pressed per each setting. Press  button once after all the settings are complete. All the weekly timer settings will be saved.
- Press  button to enter the weekly timer setting mode, and press and hold  button for 5 seconds to erase all weekly timer settings. Point the remote controller toward the indoor unit.

(5) Press  button to turn the weekly timer ON. ()

- When the weekly timer is ON, the day of the week whose timer setting is complete, will light.

Press  button again to turn the weekly timer OFF. ()

NOTE:

The saved settings will not be cleared when the weekly timer is turned OFF.

2. Checking weekly timer setting

(1) Press  button to enter the weekly timer setting mode.

* blinks.

(2) Press  or  buttons to view the setting of the particular day or number.

(3) Press  button to exit the weekly timer setting.

8-10. SMART SET (☺) OPERATION

1. How to set SMART SET operation

- (1) Press STOP/OPERATE(OFF/ON) button.
- (2) Select COOL or HEAT mode.
- (3) Press SMART SET button.
- (4) Set the temperature, fan speed, and airflow direction for SMART SET operation.

NOTE:

- SMART SET operation cannot be selected during DRY, FAN or AUTO mode operation.
- The setting range of HEAT mode SMART SET operation is 50°F (10°C) and 61 - 88°F (16 - 31°C).
- 2 groups of setting can be saved. (One for COOL, one for HEAT)
- SMART SET operation and the weekly timer operation cannot be used together.
- SMART SET operation and SLEEP operation cannot be set at the same time



2. How to cancel operation

- Press SMART SET button again.
- SMART SET operation can also be cancelled by pressing OPERATION SELECT button to change the operation mode. The preferred setting can be saved for the next time with a single press of SMART SET button.

8-11. SLEEP (Z) OPERATION

1. How to set SLEEP operation

- (1) Press STOP/OPERATE (OFF/ON) button.
- (2) Select COOL, DRY, HEAT or FAN mode.
- (3) Press SLEEP (Z) button.

(4) PRESS TEMPERATURE buttons [ (Increase) and  (Decrease)] to set the temperature of SLEEP operation.

Fan speed: AUTO

Horizontal vane: Position set on the remote controller

Operation indicator lamp: Dimly lit

- Once the above procedure is completed, the settings will be saved.
- After the settings are saved, a single push of SLEEP (Z) button during operation activates SLEEP operation with the same settings every time.
- Temperature for SLEEP operation cannot be set during DRY or FAN mode.

Set temperature for SLEEP operation

For about 30 minutes after SLEEP (Z) button is pressed, the set temperature remains as set for the operation running when SLEEP button is pressed. It will change to the set temperature for SLEEP operation in about 30 minutes.

Pressing SLEEP (Z) button again returns the operation to the previous settings.

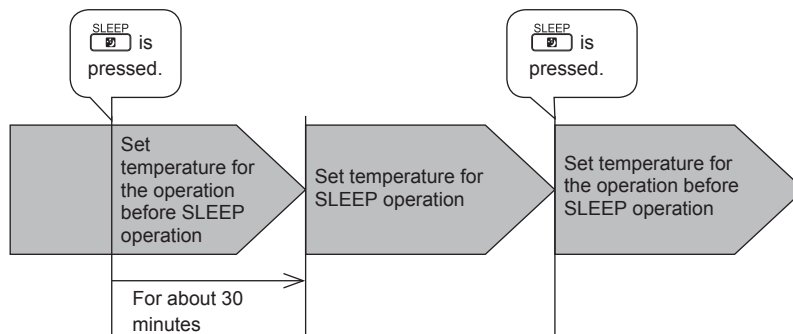

NOTE:

- ON/OFF timer is available during SLEEP operation.
- When a preset ON time for the weekly timer becomes during SLEEP operation, the weekly timer operation has priority. SLEEP operation will be cancelled, and the operation set on the weekly timer will start.

2. How to cancel operation

- Press SLEEP (Z) button again.
- The operation returns to the previous settings.
- SLEEP operation is also cancelled when the FAN button is pressed or the operation mode is changed.

NOTE: SLEEP operation and SMART SET operation cannot be set at same time.

8-12. EMERGENCY/TEST OPERATION

In the case of test run operation or emergency operation, use the emergency operation switch on the right side of the indoor unit. Emergency operation is available when the remote controller is missing or has failed, or the batteries in the remote controller are running down. The unit will start and OPERATION INDICATOR lamp will light up.

The first 30 minutes of operation is the test run operation. This operation is for servicing. The indoor fan runs at High speed and the temperature control does not work.

After 30 minutes of test run operation, the system shifts to EMERGENCY COOL/HEAT MODE with a set temperature of 75°F(24°C). The fan speed shifts to Medium.

The coil frost prevention works even in the test run or the emergency operation.

In the test run or emergency operation, the horizontal vane operates in VANE AUTO (@) mode.

Emergency operation continues until the emergency operation switch is pressed once or twice or the unit receives any signal from the remote controller. In the latter case normal operation will start.

NOTE: Do not press the emergency operation switch during normal operation.

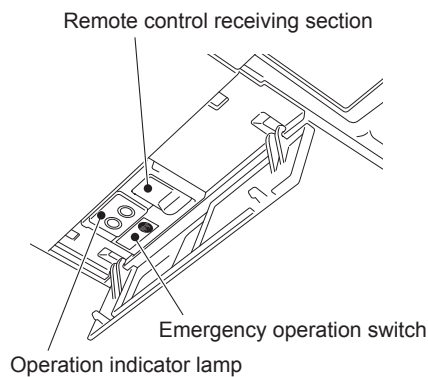

Operation mode	COOL/HEAT
Set temperature	75°F(24°C)
Fan speed	Medium
Horizontal vane	Auto

The operation mode is indicated by the Operation Indicator lamp as following

Operation Indicator lamp

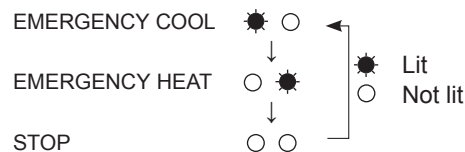

8-13. 3-MINUTE TIME DELAY OPERATION

When the system turns OFF, compressor will not restart for 3 minutes as 3-minute time delay function operates to protect compressor from overload.

8-14. Changing temperature indication (°F/°C)

- The preset unit is °F.
- °F → °C: Press RESET button while the TEMPERATURE buttons are pressed.
- °C → °F: Press RESET button while the TEMPERATURE buttons are pressed.

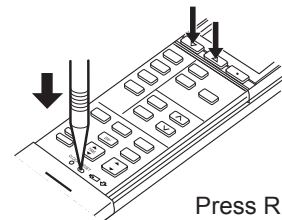

Press RESET button gently using a fine-tipped object.

MLZ-KP09NA MLZ-KP12NA MLZ-KP18NA MLZ-KP09NA2 MLZ-KP12NA2 MLZ-KP18NA2

9-1. CAUTIONS ON TROUBLESHOOTING

1. Before troubleshooting, check the following:

- 1) Check the power supply voltage.
- 2) Check the indoor/outdoor connecting wire for miswiring.

2. Take care of the following during servicing

- 1) Before servicing the air conditioner, be sure to turn off the unit first with the remote controller, and then after confirming the horizontal vane is closed, turn off the breaker and/or disconnect the power plug.
- 2) Be sure to turn OFF the power supply before removing the front panel, the cabinet, the top panel, and the electronic control P.C. board.
- 3) When removing the electronic control P.C. board, hold the edge of the board with care NOT to apply stress on the components.
- 4) When connecting or disconnecting the connectors, hold the connector housing. DO NOT pull the lead wires.

<Incorrect>



Lead wiring

<Correct>

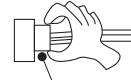

Connector housing

3. Troubleshooting procedure

- 1) Check if the OPERATION INDICATOR lamp on the indoor unit is blinking ON and OFF to indicate an abnormality. To make sure, check how many times the OPERATIONAL INDICATOR lamp is blinking ON and OFF before starting service work.
- 2) Before servicing, verify that all connectors and terminals are connected properly.
- 3) When the electronic control P.C. board seems to be defective, check for disconnection of the copper foil pattern and burnt or discolored components.
- 4) Refer to 9-2, 9-3 and 9-4.

4. How to replace batteries

Weak batteries may cause the remote controller malfunction.

In this case, replace the batteries to operate the remote controller normally.

- ① Remove the front lid and insert batteries. Then reattach the front lid.

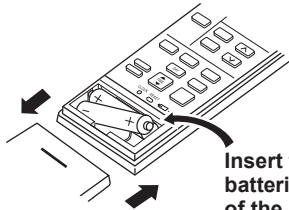

Insert the negative pole of the batteries first. Check if the polarity of the batteries is correct.

- ② Press RESET button with a fine-tipped object, and then use the remote controller.

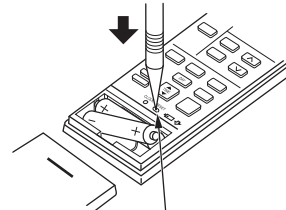

RESET button

NOTE: 1. If RESET button is not pressed, the remote controller may not operate correctly.

2. This remote controller has a circuit to automatically reset the microprocessor when batteries are replaced.

This function is equipped to prevent the microprocessor from malfunctioning due to the voltage drop caused by the battery replacement.

3. Do not use the leaking batteries.

INFORMATION FOR MULTI SYSTEM AIR CONDITIONER

OUTDOOR UNIT : MXZ series

Multi system air conditioner can connect two or more indoor units with one outdoor unit.

- Unit will not operate in case the total capacity of indoor units exceeds the capacity of outdoor units. Do not connect indoor units beyond the outdoor unit capacity. Operation indicator lamp blinks as shown in the figure below.
- When you try to operate two or more indoor units with one outdoor unit simultaneously, one for the cooling and the other for heating, the operation mode of the indoor unit that operates earlier is selected. The other indoor units cannot operate and indicate as shown in the figure below. In this case, please set all the indoor units to the same operation mode.

OPERATION INDICATOR

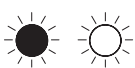

Lit



Blinking



Not lit

- When indoor units start operation while the defrosting of outdoor unit is being done, it takes a few minutes (maximum 10 minutes) to blow out the warm air.
- In the heating operation, though indoor unit that does not operate may get warm or the sound of refrigerant flowing may be heard, they are not malfunction. The reason is that the refrigerant continuously flows into it.

9-2. FAILURE MODE RECALL FUNCTION

Outline of the function

This air conditioner can memorize the abnormal condition which has occurred once.

Even though LED indication listed on the troubleshooting check table (9-4.) disappears, the memorized failure details can be recalled.

1. Flow chart of failure mode recall function for the indoor/outdoor unit

Operational procedure

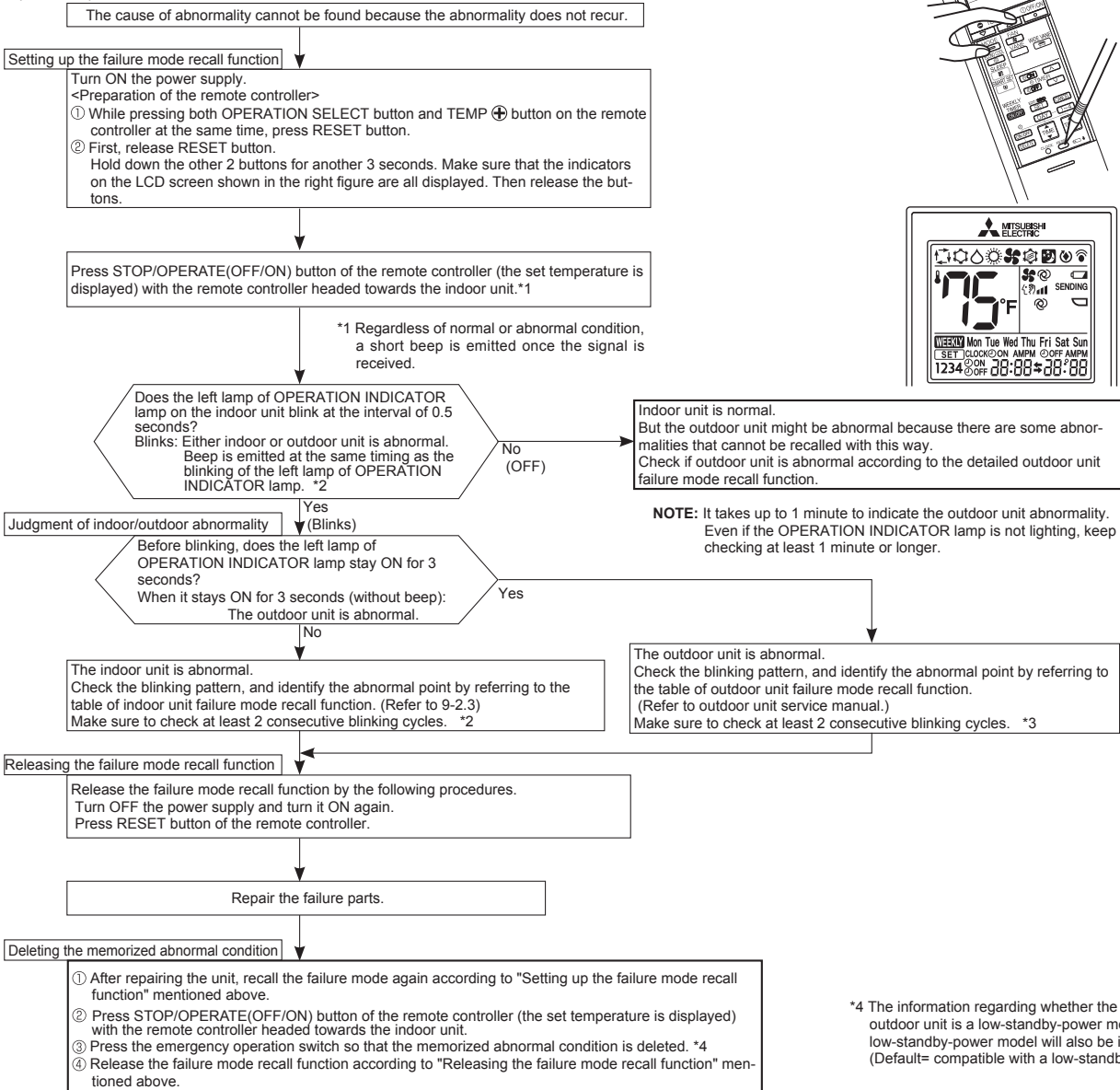

NOTE: 1. Make sure to release the failure mode recall function after it is set up, otherwise the unit cannot operate properly.
 2. If the abnormal condition is not deleted from the memory, the last abnormal condition is kept memorized.

*2. Blinking pattern when the indoor unit is abnormal:

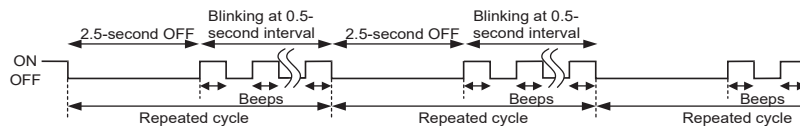

*3. Blinking pattern when the outdoor unit is abnormal:

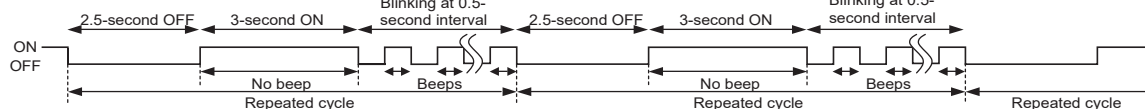

2. Flow chart of the detailed outdoor unit failure mode recall function

Operational procedure

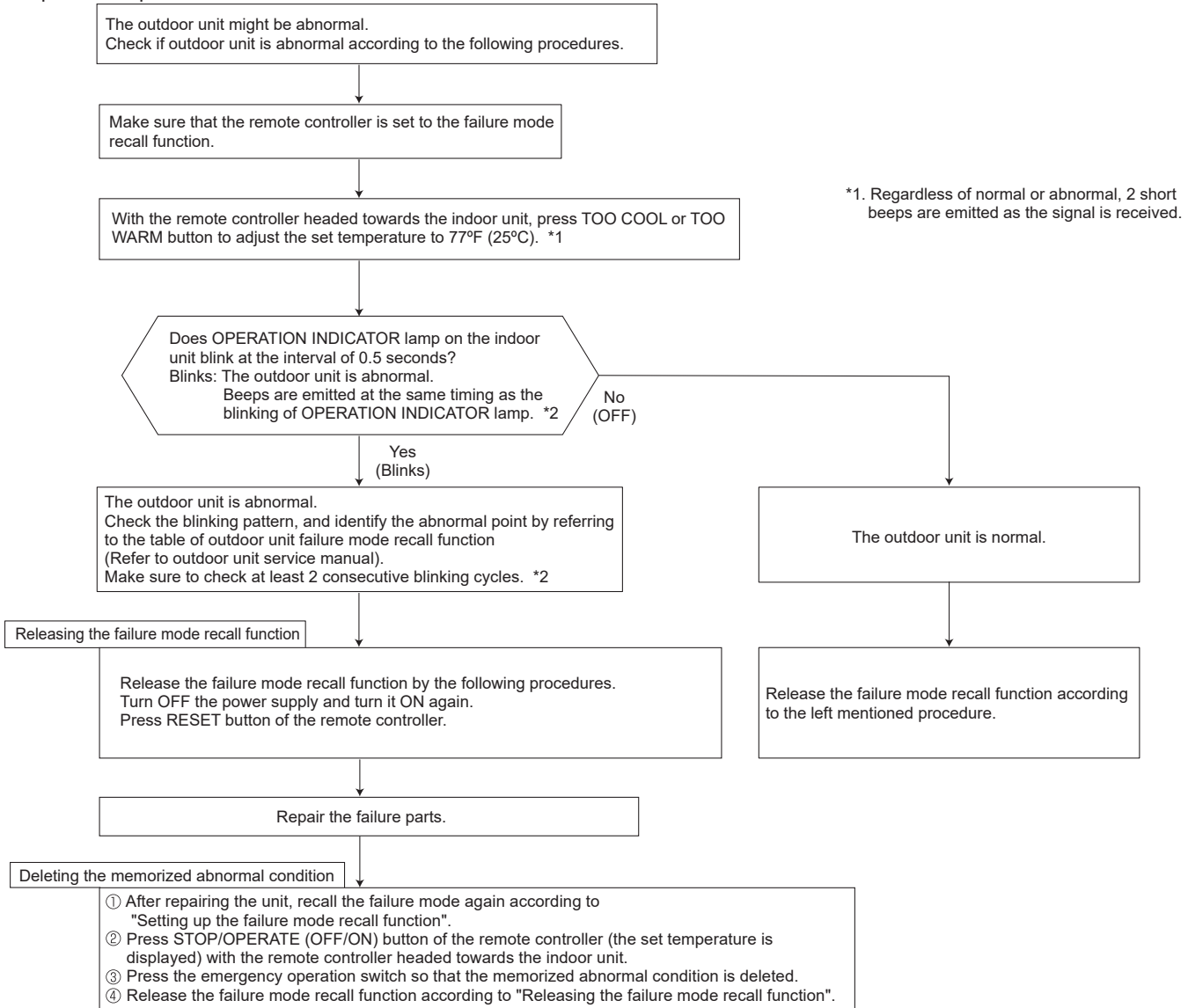

Note1. Make sure to release the failure mode recall function after it is set up, otherwise the unit cannot operate properly.
2. If the abnormal condition is not deleted from the memory, the last abnormal condition is kept memorized.

*2. Blinking pattern when outdoor unit is abnormal:

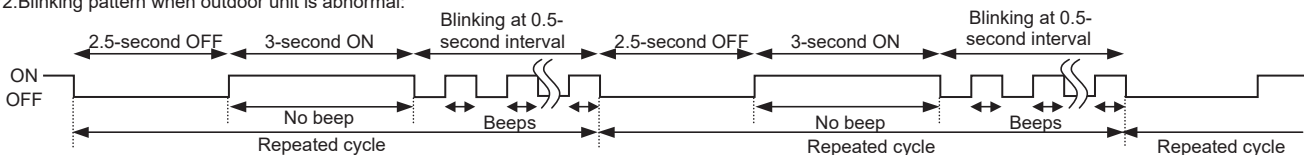

3. Table of indoor unit failure mode recall function

NOTE: Blinking patterns of this mode differs from the ones of Troubleshooting check table (9-4.).

Left lamp of OPERATION INDICATOR lamp	Right lamp of OPERATION INDICATOR lamp	Abnormal point (Failure mode)	Condition	Remedy
Not lit	Not lit	Normal	—	—
1-time blink every 0.5-second	Not lit	Room temperature thermistor	When the room temperature thermistor short or open circuit is detected every 8 seconds during operation.	Refer to the characteristics of the room temperature thermistor (9-7.).
2-time blink 2.5-second OFF	Not lit	Indoor coil thermistor (Main 1, 2 and sub) [Main 2: MLZ-KP18NA/KP18NA2]	When the indoor coil thermistor short or open circuit is detected every 8 seconds during operation.	Refer to the characteristic of the main 1,2 indoor coil thermistor and the sub indoor coil thermistor (9-7.).
3-time blink 2.5-second OFF	Not lit	Serial signal error	When the serial signal from the outdoor unit is not received for a maximum of 6 minutes.	Refer to 9-6. ④ "How to check miswiring and serial signal error".
5-time blink 2.5-second OFF	Not lit	Drain pump Float sensor	<ul style="list-style-type: none"> • Float sensor is open. • Float sensor detects abnormal water level. 	<ul style="list-style-type: none"> • Check the float sensor and the drain pump. • Check the connectors of float sensor and the drain pump. • Refer to 9-6. ⑤ "Check of float sensor".
11-time blink 2.5-second OFF	Not lit	Indoor fan motor	When the rotational frequency feedback signal is not emitted during 12 seconds the indoor fan operation.	Refer to 9-6. ⑥ "Check of indoor fan motor".
12-time blink 2.5-second OFF	Not lit	Indoor control system	When it cannot properly read data in the nonvolatile memory of the indoor electronic control P.C. board.	Replace the indoor electronic control P.C. board.
13-time blink 2.5-second OFF	Not lit	Indoor coil thermistor (Main 3) [MLZ-KP18NA/KP18NA2]	When the indoor coil thermistor short or open circuit is detected every 8 seconds during operation.	Refer to the characteristic of the main 3 indoor coil thermistor (9-7.).

9-3. INSTRUCTION OF TROUBLESHOOTING

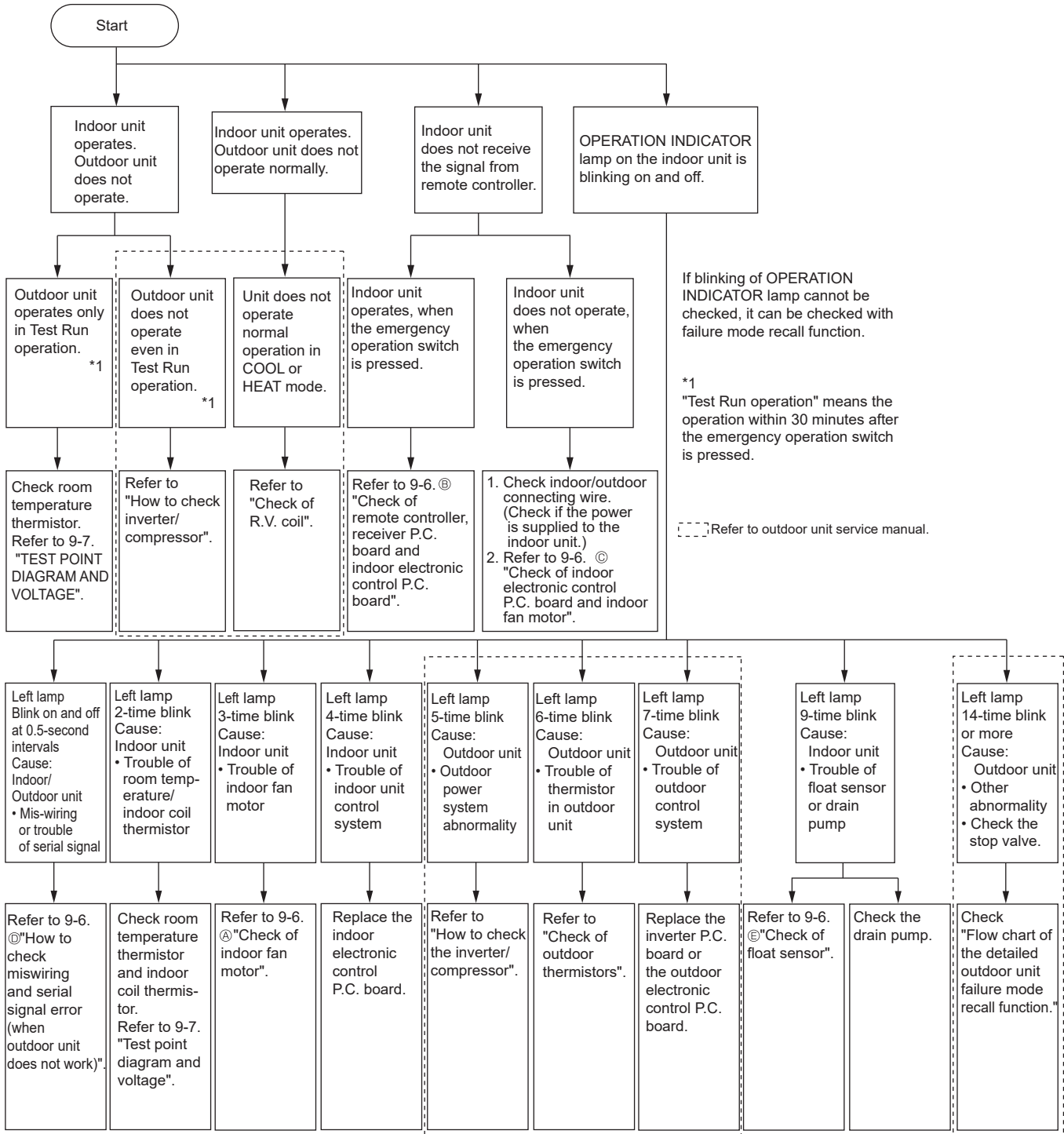

9-4. TROUBLESHOOTING CHECK TABLE

OPERATION INDICATOR



Lit

Blinking

Not lit

· Blinking of OPERATION INDICATOR lamp (left-hand side lamp) indicates abnormalities.

NOTE: Before taking measures, make sure that the symptom reappears for accurate troubleshooting.

Self check table

No.	Abnormal point	Operation indicator lamp	Symptom	Condition	Remedy
1	Miswiring or serial signal	Left lamp blinks. 0.5-second ON 0.5-second OFF	Indoor unit and outdoor unit do not operate.	When the serial signal from the outdoor unit is not received for a maximum of 6 minutes.	<ul style="list-style-type: none"> Refer to 9-6. ② "How to check miswiring and serial signal error".
2	Indoor coil thermistor Room temperature thermistor	Left lamp blinks. 2-time blink 2.5-second OFF	Indoor unit and outdoor unit do not operate.	When the indoor coil or the room temperature thermistor is shorts or opens circuit.	<ul style="list-style-type: none"> Refer to the characteristics of indoor coil thermistor, and the room temperature thermistor on 9-7.
3	Indoor fan motor	Left lamp blinks. 3-time blink 2.5-second OFF	Indoor unit and outdoor unit do not operate.	When the rotational frequency feedback signal is not emitted during the indoor fan operation.	<ul style="list-style-type: none"> Refer to 9-6. ④ "Check of indoor fan motor".
4	Indoor control system	Left lamp blinks. 4-time blink 2.5-second OFF	Indoor unit and outdoor unit do not operate.	When it cannot properly read data in the nonvolatile memory of the indoor electronic control P.C. board.	<ul style="list-style-type: none"> Replace the indoor electronic control P.C. board.
5	Outdoor power system	Left lamp blinks. 5-time blink 2.5-second OFF	Indoor unit and outdoor unit do not operate.	The compressor stops 3 times consecutively for over current protection or start-up failure protection within 1 minute after start-up.	<ul style="list-style-type: none"> Refer to "Check of inverter/compressor". Check the stop valve. Refer to outdoor unit service manual.
6	Outdoor thermistors	Left lamp blinks. 6-time blink 2.5-second OFF	Indoor unit and outdoor unit do not operate.	When the outdoor thermistors short or open circuit during the compressor operation.	<ul style="list-style-type: none"> Refer to "Check of outdoor thermistor". Refer to outdoor unit service manual.
7	Outdoor control system	Left lamp blinks. 7-time blink 2.5-second OFF	Indoor unit and outdoor unit do not operate.	When it cannot properly read data in the nonvolatile memory of the inverter P.C. board or the outdoor electronic control P.C. board.	<ul style="list-style-type: none"> Replace the inverter P.C. board or the outdoor electronic control P.C. board. Refer to outdoor unit service manual.
8	Drain pump	Left lamp blinks. 9-time blink 2.5-second OFF	Indoor unit and outdoor unit do not operate.	<ul style="list-style-type: none"> Float sensor is open. Float sensor detects abnormal water level. 	<ul style="list-style-type: none"> Check the float sensor characteristics. Check the drain pump. Check the drain pipe. Check the connectors of float sensor and the drain pump. Refer to 9-6. ⑤ "Check of float sensor".
9	Other abnormality	Left lamp blinks. 14-time blink or more 2.5-second OFF	Indoor unit and outdoor unit do not operate.	An abnormality other than above mentioned is detected.	<ul style="list-style-type: none"> Check the abnormality in detail using the failure mode recall function. Refer to outdoor unit service manual.

NOTE: When the indoor unit has started operation and the above failures are detected (the first detection after the power ON), the indoor electronic control P.C. board turns OFF the indoor fan motor with OPERATION INDICATOR lamp blinking.

OPERATION INDICATOR

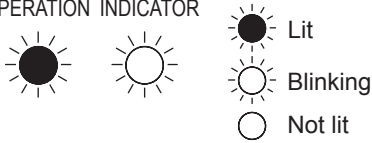

- Blinking of OPERATION INDICATOR lamp (right-hand side lamp) indicates abnormality.
- OPERATION INDICATOR lamp (left-hand side lamp) is lighted.

No.	Abnormal point	Operation indicator lamp	Symptom	Condition	Remedy
1	MXZ type Operation mode setting	<p>Right lamp blink</p> <p>2.5-second OFF</p>	Outdoor unit operates but indoor unit does not operate.	When the operation mode of the each indoor unit is differently set to COOL (includes DRY) and HEAT at the same time, the operation mode of the indoor unit that has operated at first has the priority.	<ul style="list-style-type: none"> · Unify the operation mode. Refer to outdoor unit service manual.

NOTE: When the indoor unit has started operation and the above failures are detected (the first detection after the power ON), the indoor electronic control P.C. board turns OFF the indoor fan motor with OPERATION INDICATOR lamp blinking.

9-5. TROUBLESHOOTING CRITERION OF MAIN PARTS

MLZ-KP09NA MLZ-KP12NA MLZ-KP18NA
MLZ-KP09NA2 MLZ-KP12NA2 MLZ-KP18NA2

Part name	Check method and criteria	Figure								
Room temperature thermistor (RT11)	Measure the resistance with a multimeter. [Part temperature 50°F - 86°F (10°C - 30°C)]	/								
Indoor coil thermistor (RT12,RT14,RT15 (MAIN), RT13 (SUB))	<table border="1" style="margin-left: auto; margin-right: auto;"> <tr> <td style="text-align: center;">Normal</td> </tr> <tr> <td style="text-align: center;">8 kΩ ~ 20 kΩ</td> </tr> </table>		Normal	8 kΩ ~ 20 kΩ						
Normal										
8 kΩ ~ 20 kΩ										
Indoor fan motor	Check 9-6. ④.	/								
Float sensor (FS)	<p>Disconnect connector and check with a multimeter. Check open or short according to the float position.</p> <table border="1" style="margin-left: auto; margin-right: auto;"> <tr> <td rowspan="2" style="text-align: center; vertical-align: middle;">Float position</td> <td style="text-align: center;">Float sensor</td> <td style="text-align: center;">Float sensor</td> </tr> <tr> <td style="text-align: center;">Float</td> <td style="text-align: center;">Float</td> </tr> <tr> <td style="text-align: center;">Normal</td> <td style="text-align: center;">Short</td> <td style="text-align: center;">Open</td> </tr> </table>	Float position	Float sensor	Float sensor	Float	Float	Normal	Short	Open	/
Float position	Float sensor		Float sensor							
	Float	Float								
Normal	Short	Open								
Drain pump (DP)	<p>Measure the resistance between the terminals with a multimeter. [Part temperature 50°F - 86°F (10°C - 30°C)]</p> <table border="1" style="margin-left: auto; margin-right: auto;"> <tr> <td style="text-align: center;">Color of the lead wire</td> <td style="text-align: center;">Normal</td> </tr> <tr> <td style="text-align: center;">BLUE-BLUE (Drain pump side)</td> <td rowspan="2" style="text-align: center;">520Ω ~ 620Ω</td> </tr> <tr> <td style="text-align: center;">RED-RED (Control P.C. board side)</td> </tr> </table>	Color of the lead wire	Normal	BLUE-BLUE (Drain pump side)	520Ω ~ 620Ω	RED-RED (Control P.C. board side)	/			
Color of the lead wire	Normal									
BLUE-BLUE (Drain pump side)	520Ω ~ 620Ω									
RED-RED (Control P.C. board side)										
Horizontal vane motor (MV1)	<p>Measure the resistance between the terminals with a multimeter. [Part temperature 68°F - 86°F (20°C - 30°C)]</p> <table border="1" style="margin-left: auto; margin-right: auto;"> <tr> <td style="text-align: center;">Color of the lead wire</td> <td style="text-align: center;">Normal</td> </tr> <tr> <td style="text-align: center;">RED-YLW</td> <td style="text-align: center;">Each phase 300Ω</td> </tr> </table>	Color of the lead wire	Normal	RED-YLW	Each phase 300Ω					
Color of the lead wire	Normal									
RED-YLW	Each phase 300Ω									
Vertical vane motor (MV2)	<p>Measure the resistance between the terminals with a multimeter. [Part temperature 68°F - 86°F (20°C - 30°C)]</p> <table border="1" style="margin-left: auto; margin-right: auto;"> <tr> <td style="text-align: center;">Color of the lead wire</td> <td style="text-align: center;">Normal</td> </tr> <tr> <td style="text-align: center;">RED-YLW</td> <td style="text-align: center;">Each phase 300Ω</td> </tr> </table>	Color of the lead wire	Normal	RED-YLW	Each phase 300Ω					
Color of the lead wire	Normal									
RED-YLW	Each phase 300Ω									

9-6. TROUBLESHOOTING FLOW

When the left lamp of OPERATION INDICATOR lamp blinks 3 times and the right lamp of OPERATION INDICATOR lamp is not lighted.
Indoor fan does not operate.

A Check of indoor fan motor

The indoor fan motor error has occurred, and the indoor fan does not operate.

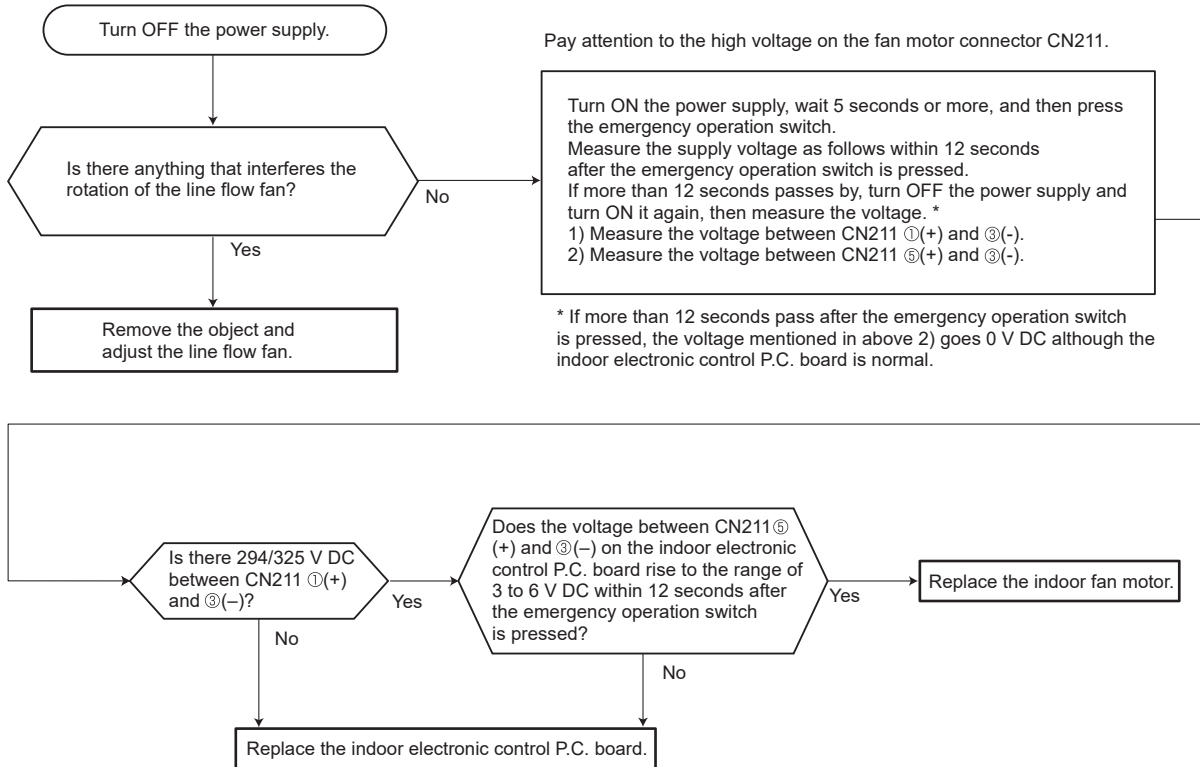

The indoor fan motor error has occurred, and the indoor fan repeats "12-second ON and 30-second OFF" 3 times, and then stops.

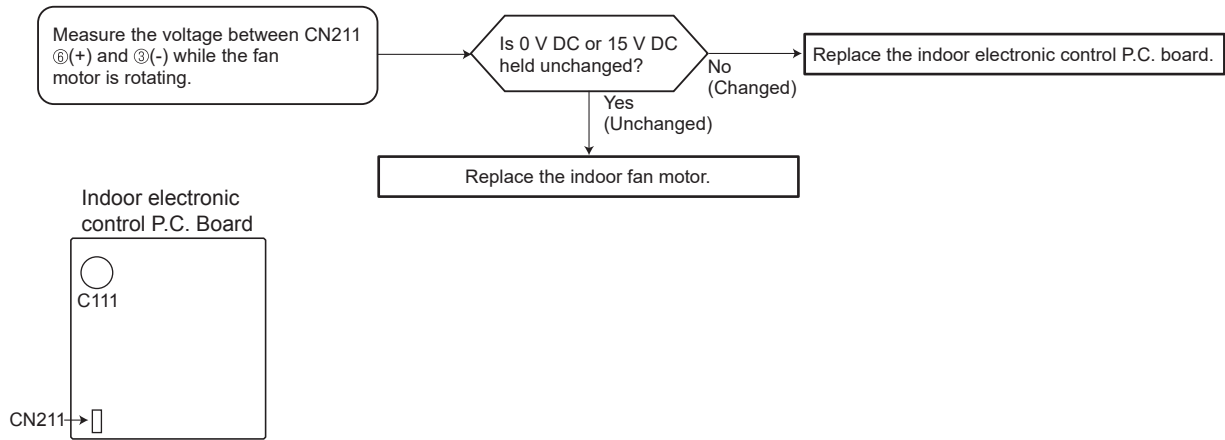

Indoor unit operates by pressing the emergency operation switch, but does not operate with the remote controller.

Ⓑ Check of remote controller, receiver P.C. board and indoor electronic control P.C. board

* Check if the remote controller is exclusive for this air conditioner.

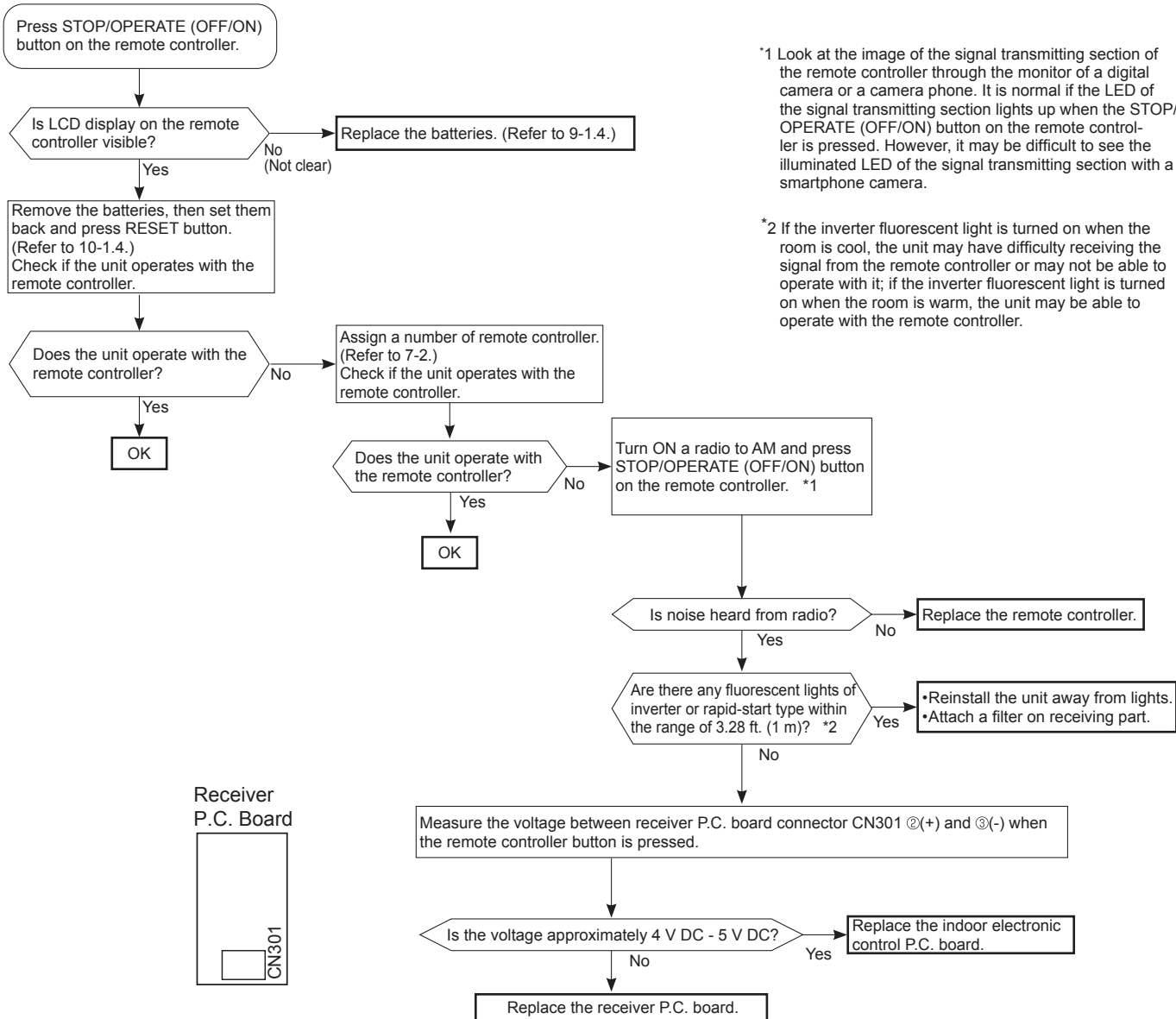

*1 Look at the image of the signal transmitting section of the remote controller through the monitor of a digital camera or a camera phone. It is normal if the LED of the signal transmitting section lights up when the STOP/OPERATE (OFF/ON) button on the remote controller is pressed. However, it may be difficult to see the illuminated LED of the signal transmitting section with a smartphone camera.

*2 If the inverter fluorescent light is turned on when the room is cool, the unit may have difficulty receiving the signal from the remote controller or may not be able to operate with it; if the inverter fluorescent light is turned on when the room is warm, the unit may be able to operate with the remote controller.

The unit cannot be operated with the remote controller.
 Also, OPERATION INDICATOR lamp does not light up by pressing the emergency operation switch.

© Check of indoor electronic control P.C. board and indoor fan motor

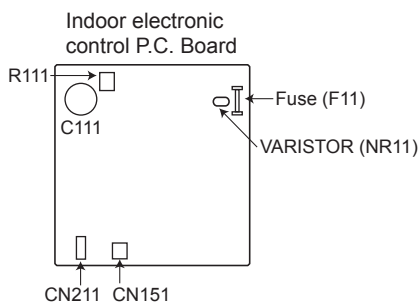
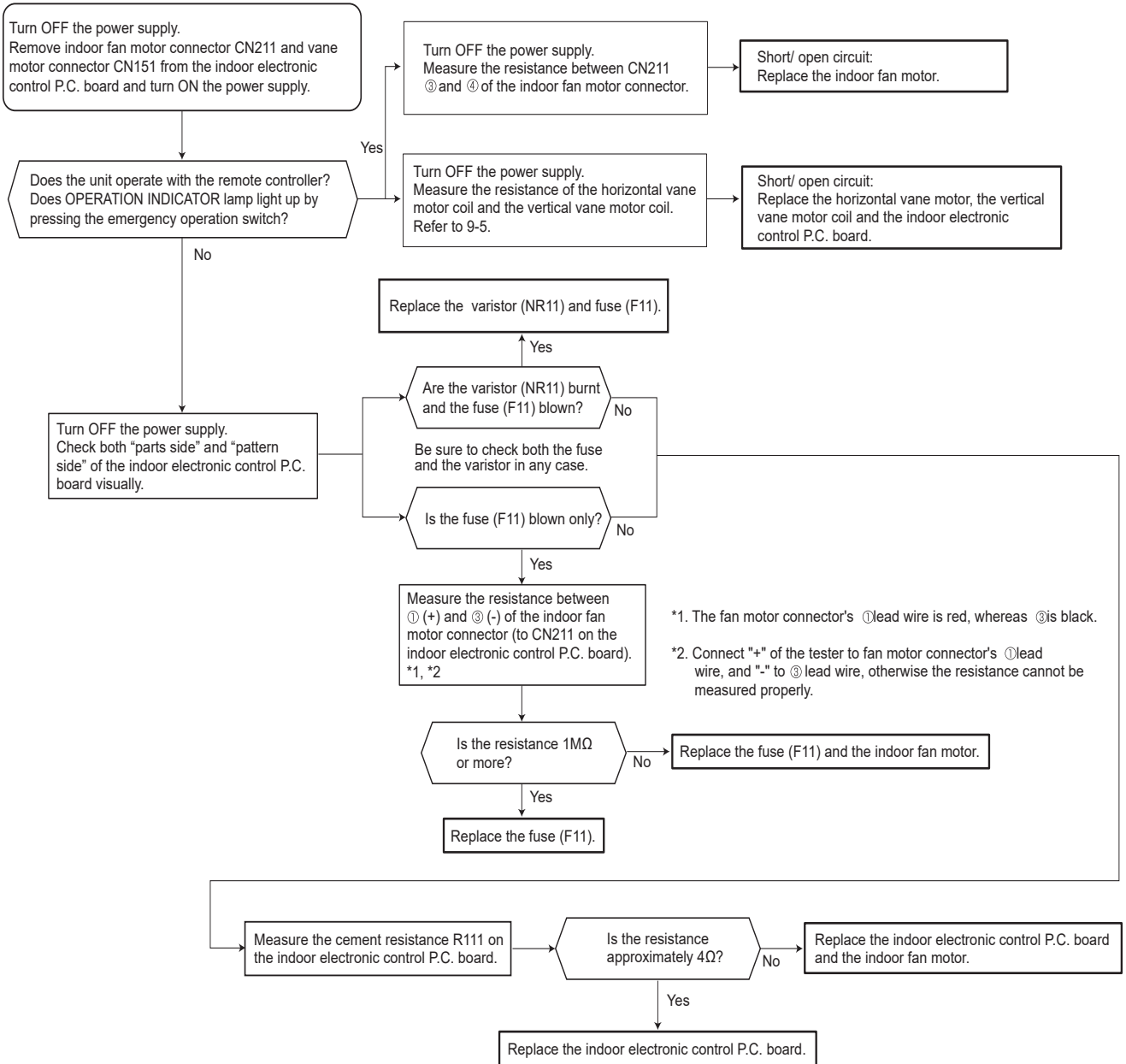

When the left lamp of OPERATION INDICATOR lamp blinks ON and OFF in every 0.5-second.
Outdoor unit does not operate.

D How to check miswiring and serial signal error

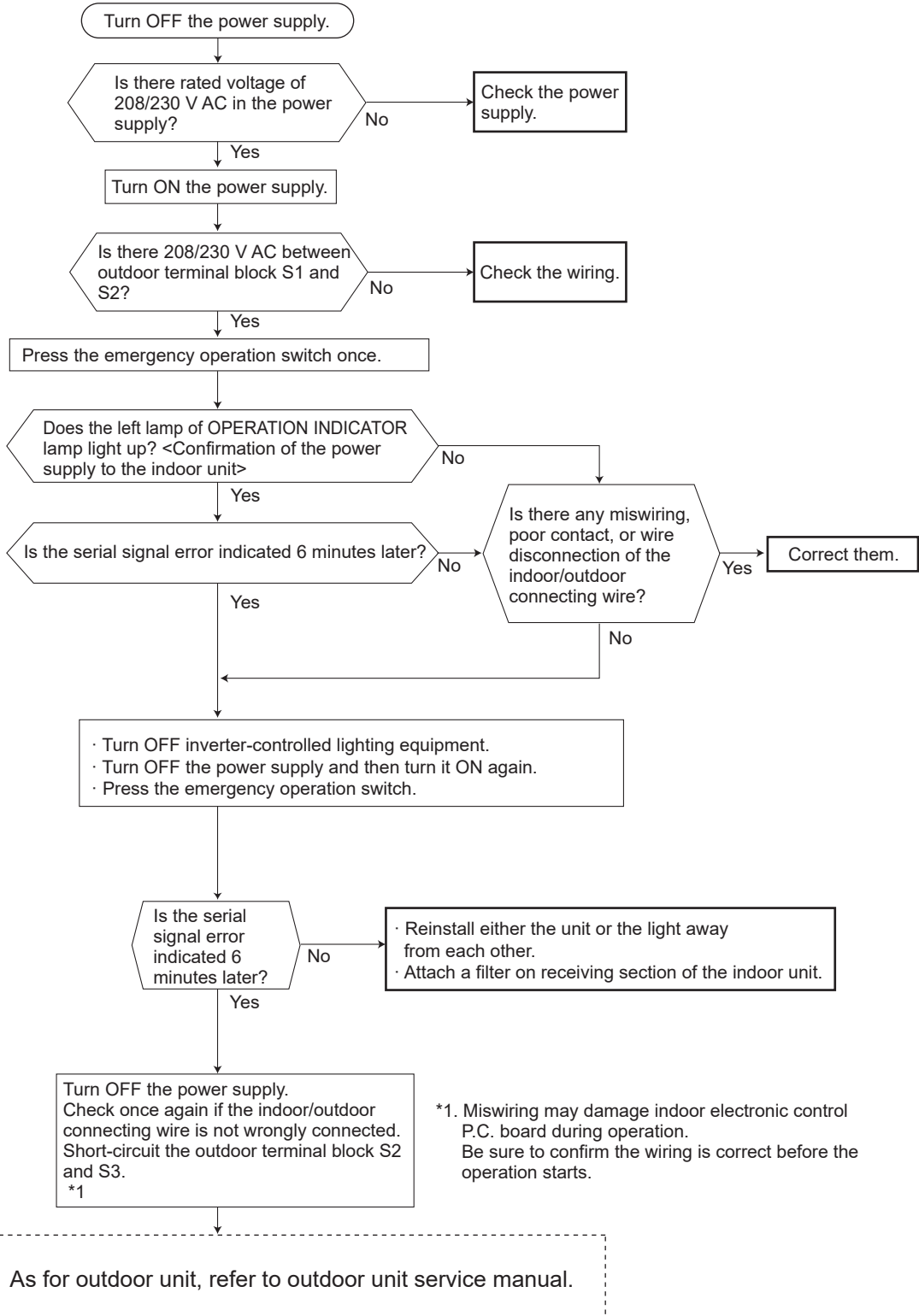

*1. Miswiring may damage indoor electronic control P.C. board during operation. Be sure to confirm the wiring is correct before the operation starts.

When the left lamp of OPERATION INDICATOR lamp blinks 9-time.
Indoor unit and outdoor unit do not operate.

E Check of float sensor

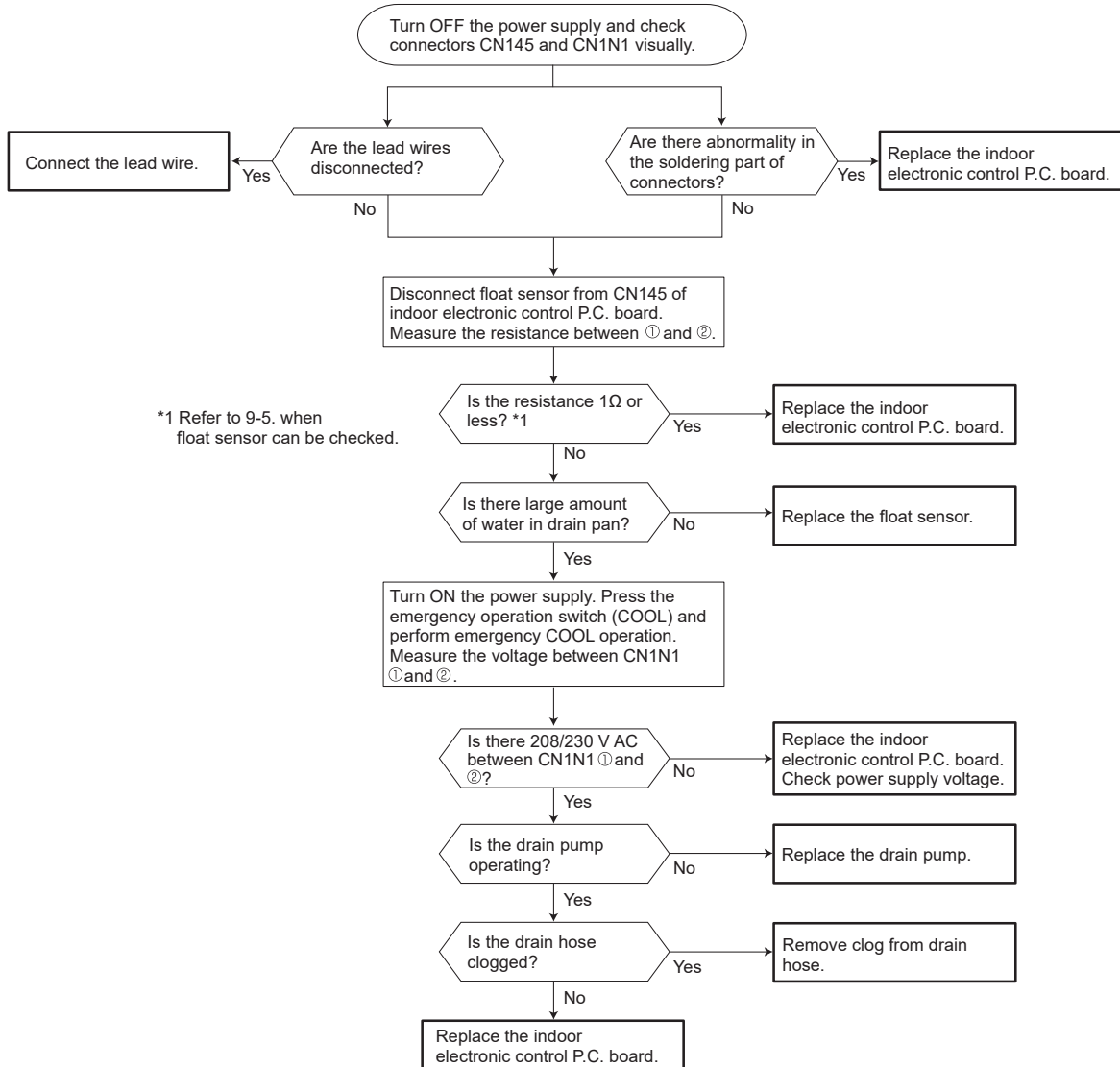

*1 Refer to 9-5. when float sensor can be checked.

Indoor electronic control P.C. board

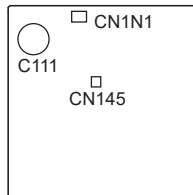

F Electromagnetic noise enters into TV sets or radios

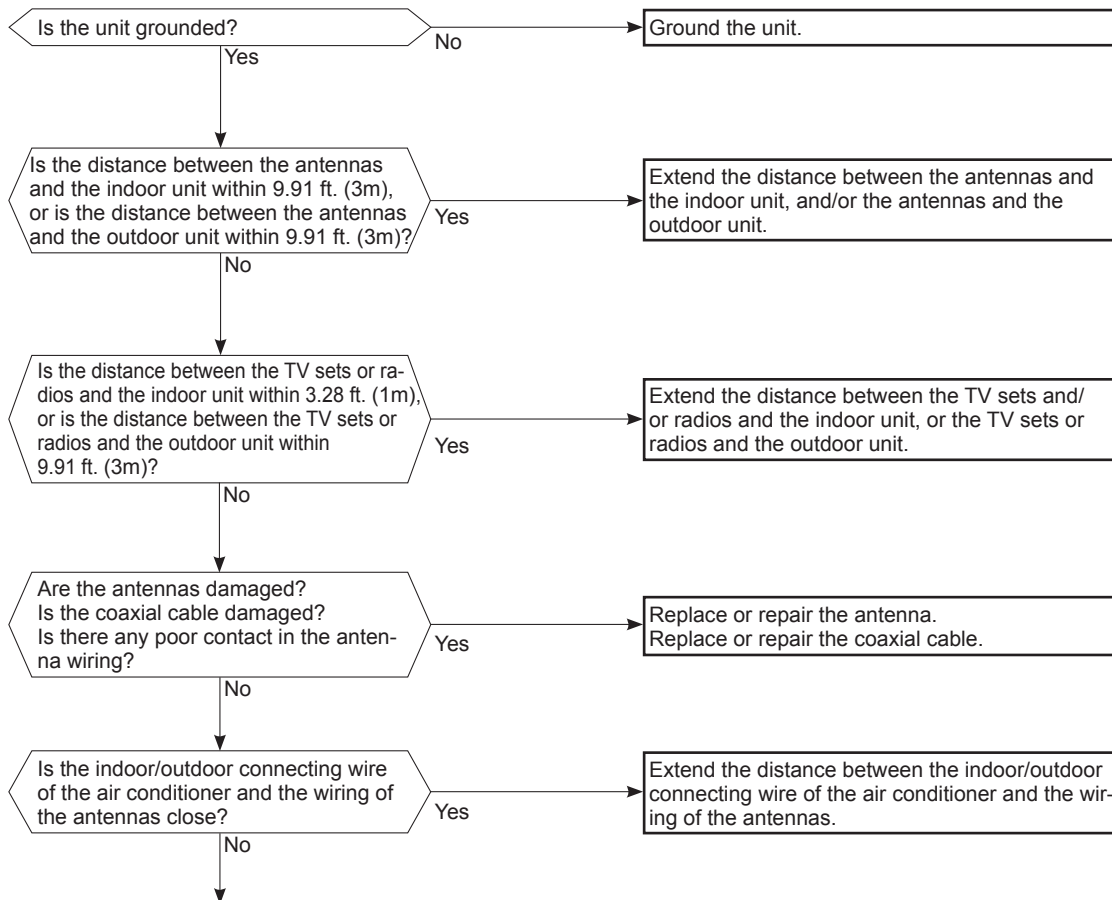

Even if all of the above conditions are fulfilled, the electromagnetic noise may enter, depending on the electric field strength or the installation condition (combination of specific conditions such as antennas or wiring).

Check the following before asking for service.

1. Devices affected by the electromagnetic noise
TV sets, radios (FM/AM broadcast, shortwave)
2. Channel, frequency, broadcast station affected by the electromagnetic noise
3. Channel, frequency, broadcast station unaffected by the electromagnetic noise
4. Layout of:
indoor/outdoor unit of the air conditioner, indoor/outdoor wiring, ground wire, antennas, wiring from antennas, receiver
5. Electric field intensity of the broadcast station affected by the electromagnetic noise
6. Presence or absence of amplifier such as booster
7. Operation condition of air conditioner when the electromagnetic noise enters in
 - 1) Turn OFF the power supply once, and then turn ON the power supply. In this situation, check for the electromagnetic noise.
 - 2) Within 3 minutes after turning ON the power supply, press STOP/OPERATE (OFF/ON) button on the remote controller for power ON, and check for the electromagnetic noise.
 - 3) After a short time (3 minutes later after turning ON), the outdoor unit starts running. During operation, check for the electromagnetic noise.
 - 4) Press STOP/OPERATE (OFF/ON) button on the remote controller for power OFF, when the outdoor unit stops but the indoor/outdoor communication still runs on. In this situation, check for the electromagnetic noise.

9-7. TEST POINT DIAGRAM AND VOLTAGE
MLZ-KP09NA MLZ-KP12NA MLZ-KP18NA
Indoor electronic control P.C. board

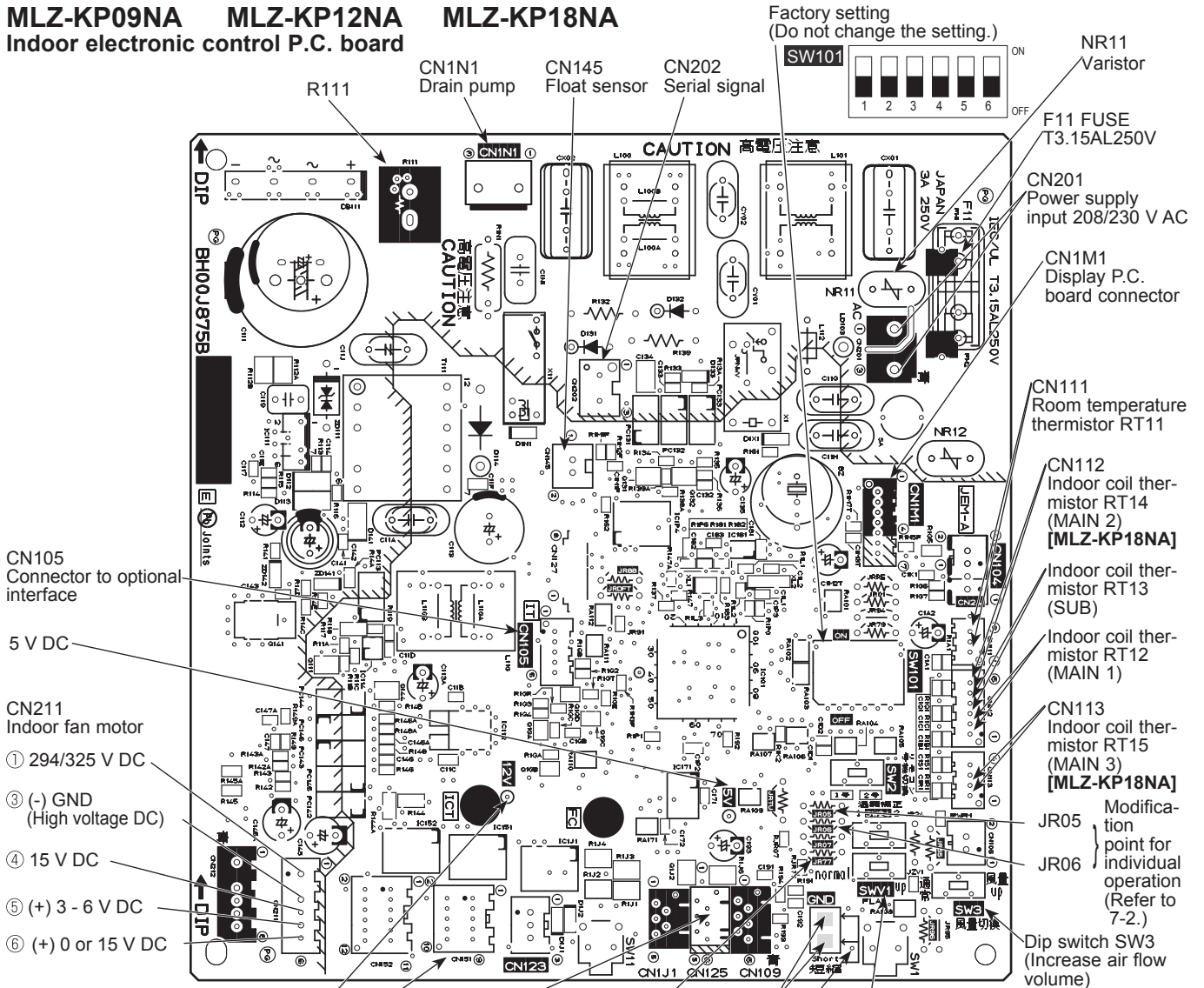

Receiver P.C. board

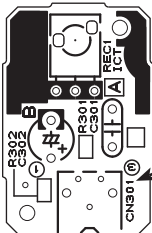

Display P.C. board

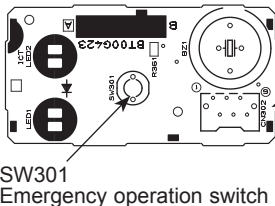

To disable "Auto restart function", cut the Jumper wire to JR77. (Refer to 7-3.)

**Indoor coil thermistor [RT12,RT14,RT15 (MAIN), RT13 (SUB)]
 Room temperature thermistor (RT11)**

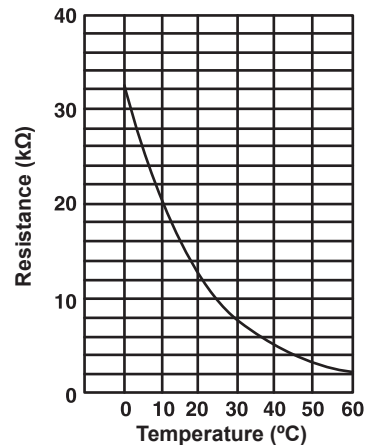

<Detaching method of the terminal with locking mechanism>

The terminal which has the locking mechanism can be detached as shown below.
 There are 2 types of the terminal with locking mechanism.
 The terminal without locking mechanism can be detached by pulling it out.
 Check the shape of the terminal before detaching.

(1) Slide the sleeve and check if there is a locking lever or not.

(2) The terminal with this connector shown below has the locking mechanism.

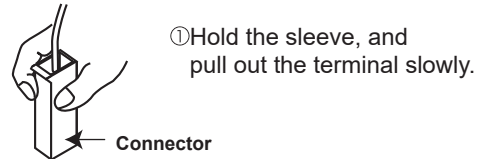
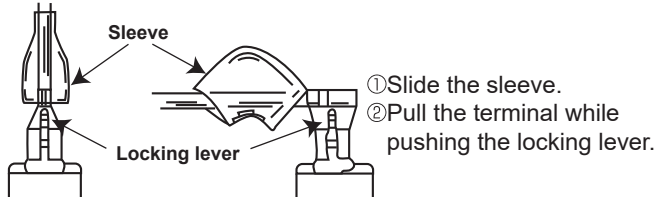

MLZ-KP09NA MLZ-KP12NA MLZ-KP18NA
MLZ-KP09NA2 MLZ-KP12NA2 MLZ-KP18NA2

NOTE: Turn OFF the power supply before disassembly.

→ : Indicates the visible parts in the photos/figures.
 ---→ : Indicates the invisible parts in the photos/figures.

OPERATING PROCEDURE	PHOTOS/FIGURES
<p>1. Removing the intake grille</p> <p>(1) Slide the tabs (2 places) of intake grille in the direction of the arrow (Figure 1).</p> <p>(2) Hold the intake grille and pull it down to open (Figure 2).</p> <p>(3) Slide the grille shafts (1 each on the left and right sides) off the intake grille and remove the intake grille (Figure 3).</p> <p>(4) Remove the safety strings of intake grille from the hooks (Figure 4).</p>	<p>Photo 1</p> <p>Remote control receiving section</p> <p>Places for installing the air cleaning filters [(Anti-Allergy Enzyme filters (option)) [Install to air filters.(Air purifying filter)]]</p> <p>Horizontal vane</p> <p>Intake grille</p> <p>Electrical parts</p> <p>Safety string</p> <p>Places for installing the air filter(Air purifying filter)</p> <p>Safety string</p> <p>Figure 1</p> <p>Tab</p> <p>Figure 2</p> <p>Figure 3</p> <p>Shaft</p> <p>Figure 4</p> <p>Safety string</p> <p>Hook</p>

OPERATING PROCEDURE

2. Removing the grille

- (1) Remove the intake grille.
- (2) Remove the fixing screws for side panels (2 screws) on the left and right sides (Figure 5).
- (3) Open the side panels on the left and right sides. Remove the safety strings from the grille and remove the side panels (Figure 5).
- (4) Open the horizontal vane completely.
- (5) Remove the screw cap in the center of air outlet (Figure 5).
- (6) Remove the fixing screws ① at 4 places on the left and right sides (Figure 6).
- (7) Remove the fixing screws ① at 2 places in the middle and the fixing screw ② in the center (Figure 6).
- (8) Remove the temporary holding tabs of the grille from the hooks of the indoor unit (Figure 6).

<Installing the grille>

- (1) Open the horizontal vane completely.
- (2) Remove the screw cap in the center of air outlet (Figure 5).
- (3) Attach the temporary holding tabs of the grille to the hooks of the indoor unit (Figure 6).
- (4) Place the grille so that it fits closely with the ceiling surface. Loosely fasten with the provided fixing screws ① at 4 places on the left and right side (Figure 6).
- (5) Tighten the fixing screws ① at 2 places in the middle and the fixing screw ② in the center (Figure 6).
- (6) Tighten the fixing screws ① at 4 places on the left and right sides.

NOTE: Make sure there are no gaps between the indoor unit and the grille, or between the grille and the ceiling surface. If there are any gaps, the wind may come in and it may cause water to drip (Figure 7).

NOTE: Tighten the fixing screws ① and ② completely (Figure 6).

NOTE: If there are any gaps between the grille and the ceiling, with the grille attached, slightly adjust the installation height of the unit and clear the gap (Figure 8).

PHOTOS/FIGURES

Figure 5

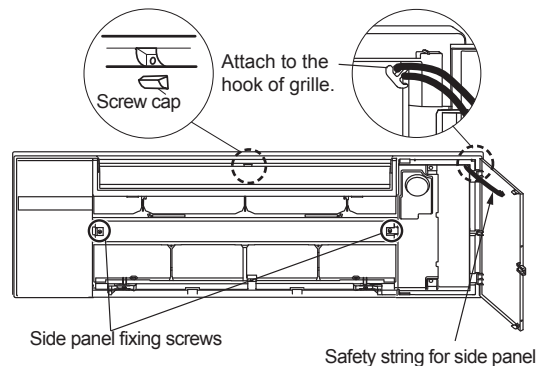

Figure 6

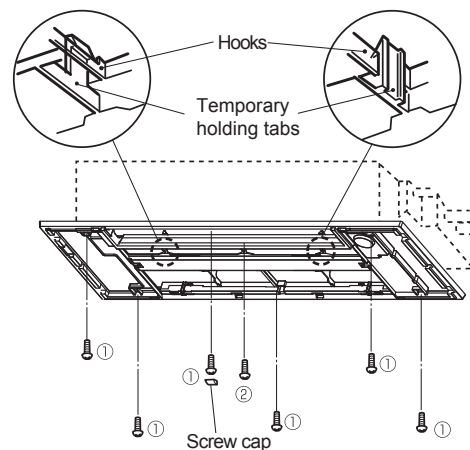

Figure 7

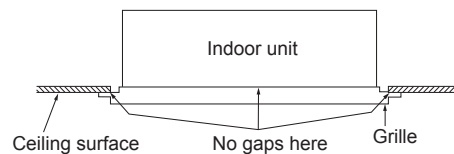
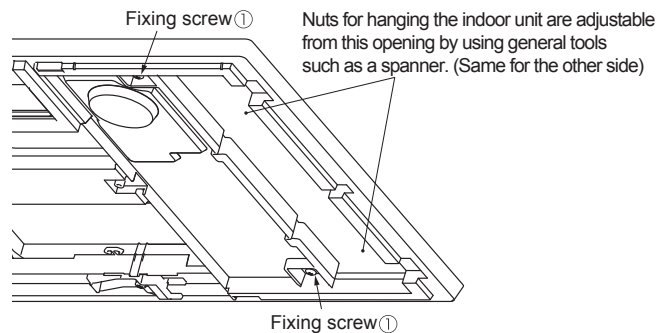

Figure 8



OPERATING PROCEDURE

- (7) Install the screw cap.
 - (8) After attaching the safety strings for the left and right side panels to the grille, install the side panels (Figure 9).
- NOTE:** Make sure that the tabs of the side panels securely fit into place (Figure 9).
- NOTE:** Open the display cover to make sure the positioning marks are aligned.
- NOTE:** Make sure that there are no gaps between the emergency operation switch and the side panel (Figure 10).
- NOTE:** Make sure that the safety strings do not hang out of the side panels.
- (9) Fix with the side panel fixing screws on the left and right sides (Figure 10).
 - (10) Attach the air cleaning filters (Anti-Allergy Enzyme filters), if any, to the catches on the air filters (Air purifier filters) (Figure 11).
 - (11) Attach the safety strings for intake grille to the grille and insert the grille shafts into the holes of the intake grille (Figure 11).
 - (12) Close the intake grille (Figure 12).
- NOTE:** Press the intake grille firmly against the grille until a click is heard from each tab on the left and right sides.

<Check after installing>

- (1) Check that there are no gaps between the indoor unit and the grille, or between the grille and the ceiling surface.
- NOTE:** If there are any gaps, the wind may come in and it may cause water to drip.
- (2) Check that the screw cap is installed.
 - (3) Check that the left and right side panels are installed securely.
 - (4) Check that the emergency operation switch is installed securely.
 - (5) Check that the display cover of side panel is installed securely.
 - (6) Check that the filters are installed securely.
- NOTE:** If the filters are not installed securely, the intake grille may not close properly.
- (7) Check that the safety strings (4 places) are attached securely.

Figure 12

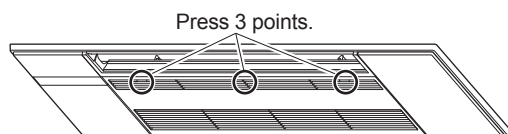

PHOTOS/FIGURES

Figure 9

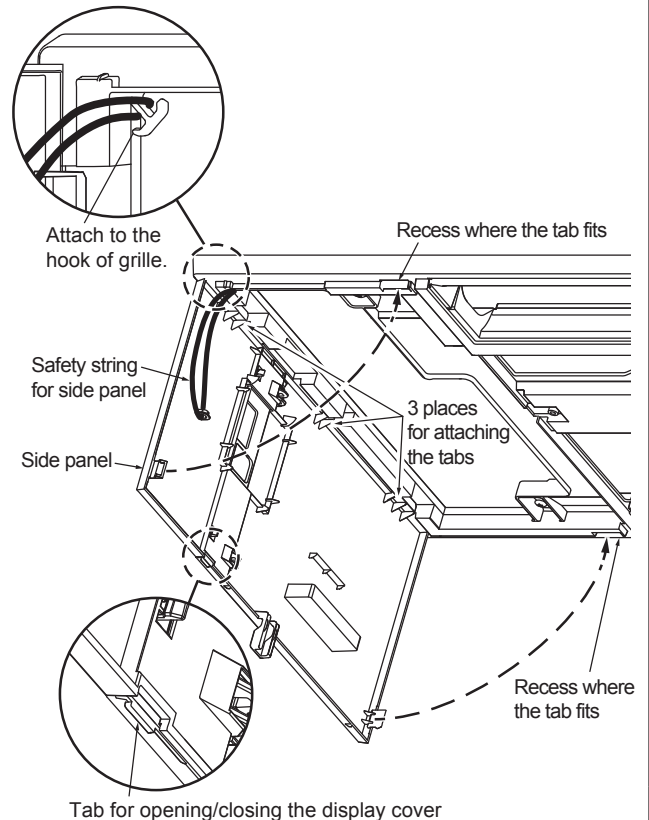

Figure 10

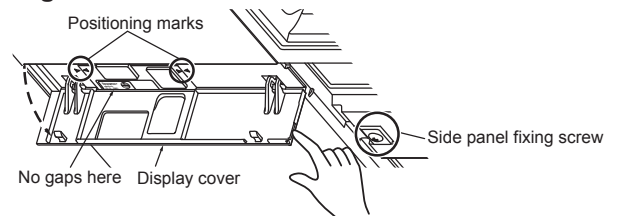
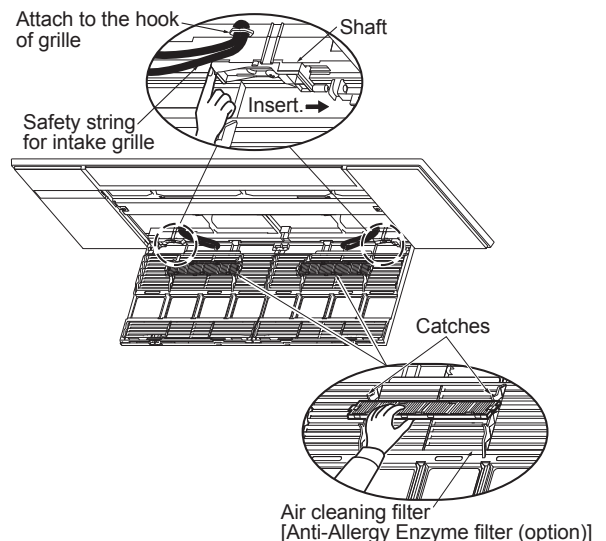

Figure 11



OPERATING PROCEDURE

3. Removing the indoor electric control P.C. board, the receiver P.C. board and the display P.C. board

- (1) Remove the intake grille.
- (2) Remove the side panel (L).
- (3) Remove the electrical cover ① and ② (4 fixing screws) (Photo 2).
- (4) Partially slide the indoor electronic control P.C. board out.
- (5) Disconnect all the connectors and lead wires on the board to remove the indoor electric control P.C. board.
- (6) Remove the tabs at the top and bottom of lamp cover, and open the lamp cover.
- (7) Disconnect the connectors and lead wires, and remove the receiver P.C. board and the display P.C. board.

4. Removing the heat exchanger and stabilizer

- (1) Remove the grille.
- (2) Remove the room temperature thermistor.
- (3) Remove the tabs (2 places) in the center of stabilizer and remove the drain pan (4 fixing screws).
- (4) Remove the electrical cover ① and ②.
- (5) Disconnect the connectors of the horizontal and vertical vane motors.
- (6) Remove the indoor coil thermistors (main and sub).
- (7) Remove the drain cover (3 fixing screws).
- (8) Remove the pipe band.
- (9) Remove the heat exchanger (6 fixing screws).
- (10) Remove the stabilizer (2 fixing screws).

5. Removing the horizontal and vertical vane motors

- (1) Remove the grille.
- (2) Remove the drain pan.
- (3) Remove the horizontal vane.
- (4) Remove the cover of horizontal and vertical vane motors (2 fixing screws).
- (5) Remove the vertical vane motor (2 fixing screws) and disconnect the connector (Photo 4).
- (6) Remove the horizontal vane motor (2 fixing screws) and disconnect the connector (Photo 4).

PHOTOS/FIGURES

Photo 2

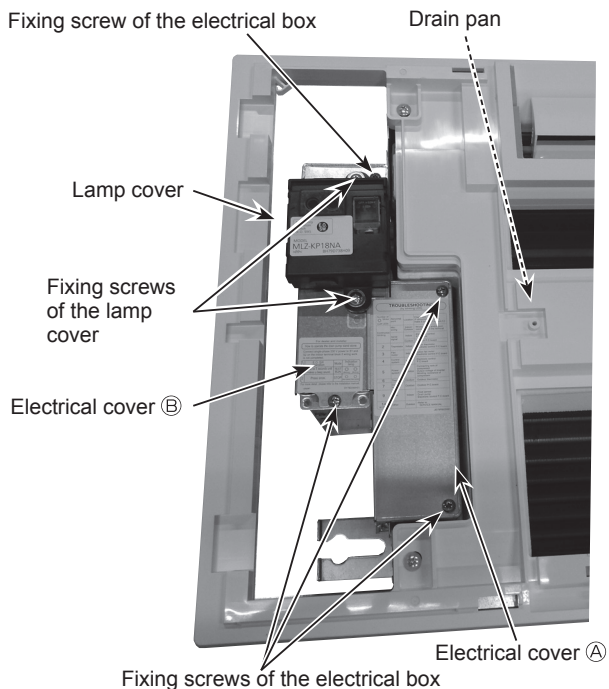

Photo 3

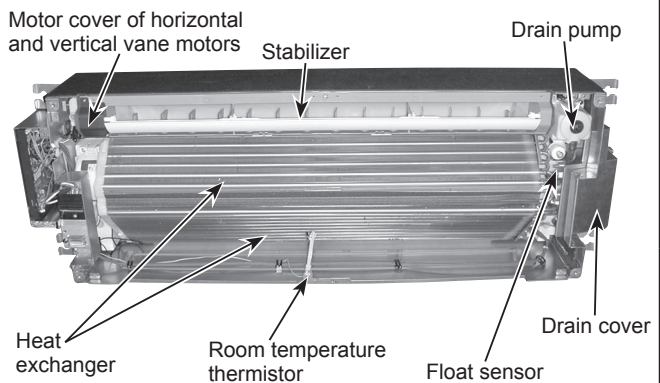
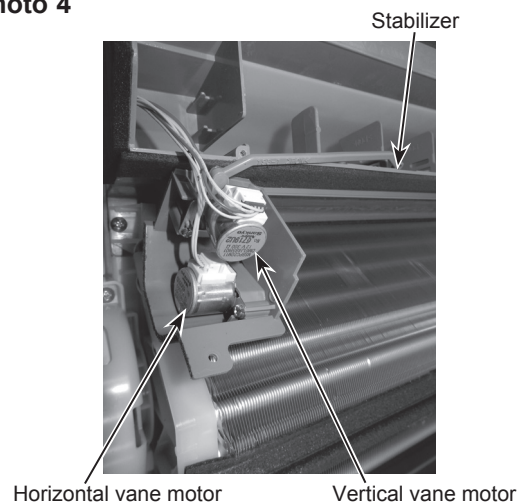
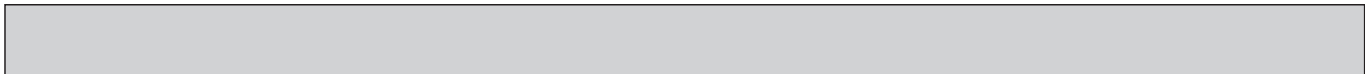
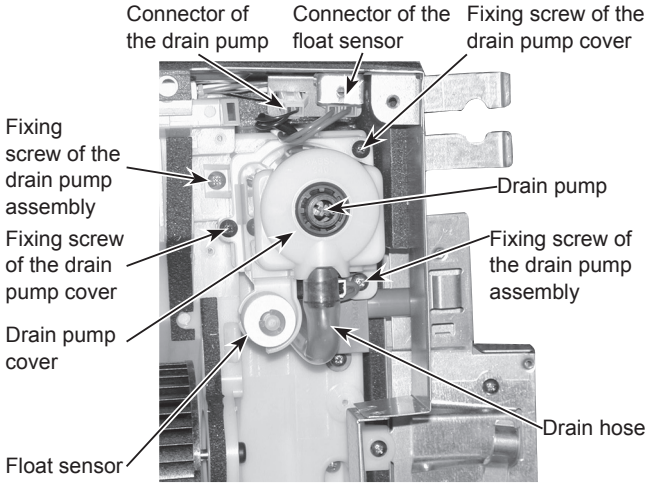
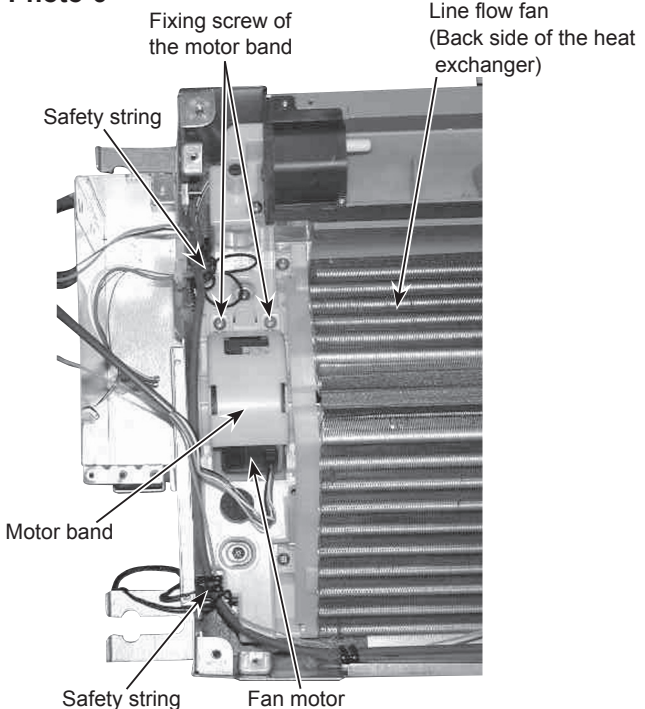

Photo 4





OPERATING PROCEDURE	PHOTOS/FIGURES
<p>6. Removing the drain pump and float sensor</p> <ol style="list-style-type: none">(1) Remove the grille.(2) Remove the drain pan.(3) Disconnect the connector of the drain pump (Photo 5).(4) Disconnect the connector of the float sensor (Photo 5).(5) Remove the drain hose (Photo 5).(6) Remove the drain pump assembly (2 fixing screws) (Photo 5).(7) Remove the drain pump cover (2 fixing screws) (Photo 5).	<p>Photo 5</p>  <p>Connector of the drain pump Connector of the float sensor Fixing screw of the drain pump cover</p> <p>Fixing screw of the drain pump assembly Drain pump</p> <p>Fixing screw of the drain pump cover Fixing screw of the drain pump assembly</p> <p>Drain pump cover Drain hose</p> <p>Float sensor</p>
<p>7. Removing the fan motor and line flow fan</p> <ol style="list-style-type: none">(1) Remove the grille.(2) Remove the drain pan.(3) Remove the drain cover.(4) Remove the pipe band.(5) Remove the electrical cover ① and ②.(6) Remove the terminal box (2 fixing screws).(7) Remove the safety strings (2 places) from the clamps and untie (Photo 6).(8) Hook the safety strings to the tabs on the side plate of indoor heat exchanger.(9) Remove the indoor heat exchanger (6 fixing screws) and slide it downward.(10) Remove the stabilizer (2 fixing screws).(11) Partially slide the indoor electric control P.C. board out.(12) Disconnect the connector (CN211) of indoor fan motor.(13) Remove the motor band (2 fixing screws) (Figure 6).(14) Remove the indoor fan motor and line flow fan. (No need to remove the indoor heat exchanger to remove these 2 items.)	<p>Photo 6</p>  <p>Fixing screw of the motor band Line flow fan (Back side of the heat exchanger)</p> <p>Safety string</p> <p>Motor band</p> <p>Safety string Fan motor</p>

mitsubishi electric corporation

HEAD OFFICE: TOKYO BUILDING, 2-7-3, MARUNOUCHI, CHIYODA-KU, TOKYO 100-8310, JAPAN

© Copyright 2018 MITSUBISHI ELECTRIC CORPORATION

Issued: Jun. 2023. No. OBH802 REVISED EDITION-D

Issued: Jan. 2023. No. OBH802 REVISED EDITION-C

Issued: Apr. 2022. No. OBH802 REVISED EDITION-B

Issued: Mar. 2019. No. OBH802 REVISED EDITION-A

Published: Mar. 2018. No. OBH802

Made in Japan

Specifications are subject to change without notice.