



IMPORTANT FOR FUTURE REFERENCE
Please complete this information and retain this manual for the life of the equipment:

Model #: _____
Serial #: _____
Date Purchased: _____

ENGLISH

Installation & Operation Manual

MKG24, MKG36, MKG48, MKG60 & MKG72

All Options



TO THE PURCHASER, OWNER AND STORE MANAGER

Please review these warnings prior to posting them in a prominent location for reference.

TO THE PURCHASER

Post in a prominent location the instructions to be followed in the event that an operator smells gas. Obtain this information from your local gas supplier.

WARNING

DO NOT store or use gasoline or other flammable vapors and liquids in the vicinity of this or any other appliance.
Do not spray aerosols in the vicinity of this appliance when it is in operation.

WARNING

Improper installation, operation, alteration, service or maintenance can cause property damage, injury or death. Read the installation, operating and maintenance instructions thoroughly before installing, operation, servicing this appliance.

WARNING

Installation, maintenance and repairs should be performed by a MagiKitch'n Authorized Service and Parts (ASAP) company technician or other qualified personnel. Installation, maintenance or repairs by unauthorized and unqualified personnel will void the warranty.

WARNING

Installation and all connections must be made according to local codes in force. In the absence of local codes in North America, the installation must conform with the National Fuel Gas Code, ANSI Z223.1/NFPA 54 or the Natural Gas and Propane Installation Code CSA B149.1 as applicable. In Australia, the appliance must be installed in compliance with AS/NZS 5601.

WARNING

During the warranty period if a customer elects to use a non-original part or modifies an original part purchased from Pitco and/or its Authorized Service and Parts (ASAP) companies, this warranty will be void. In addition, Pitco and its affiliates will not be liable for any claims, damages or expenses incurred by the customer which arises directly or indirectly, in whole or in part, due to the installation of any modified part and/or received from an unauthorized service center.

WARNING

This appliance, when installed, must be electrically grounded in accordance with local codes, or in the absence of local codes, with the National Electrical Code, ANSI/NFPA 70, or the Canadian Electrical Code, CSA C22.2, as applicable.

WARNING

Adequate means must be provided to LIMIT the movement of this appliance without depending on the gas or electrical cord connection. Single appliances equipped with legs must be stabilized by installing anchor straps. All appliances equipped with casters must be stabilized by installing restraining chains or equivalent means.

WARNING

An appliance equipped with casters and a flexible gas line must be connected to the gas supply with a quick disconnect device. In North America this quick disconnect must comply with ANSI Z24.41. In Australia, the quick disconnect must comply with AS 4627.

TO THE PURCHASER, OWNER AND STORE MANAGER

Please review these warnings prior to posting them in a prominent location for reference.



WARNING

Some surfaces of this appliance can become extremely hot during normal operation. The following symbol is affixed to the appliance to remind users to exercise caution and to always use personal safety when operating this appliance



WARNING

The power supply must be disconnected before servicing, maintaining or cleaning this appliance.

WARNING

DO NOT attempt to move this appliance or transfer hot liquids from grease box to another container when the unit is at operating temperature or filled with hot liquids. Serious personal injury could result if skin comes in contact with the hot surfaces or liquids.

WARNING

The appliance is NOT jet stream approved. DO NOT clean the appliance with a water jet.

WARNING

DO NOT use an open flame to check for gas leaks!

WARNING

DO NOT sit or stand on this appliance. The appliance's front panel, cook plate, splash back, side or workshelf are not a step. Serious injury could result from slipping, falling or contact with hot surfaces or liquids.

WARNING

NEVER use the appliance as a step for cleaning or accessing the ventilation hood. Serious injury could result from slips, trips or from contacting hot surfaces or liquids.

WARNING

DO NOT use the appliance unless it is properly secured to a table, stand or freezer / refrigerated base suited to handle the weight of the entire appliance.

WARNING

This appliance is intended for indoor use only.

WARNING

DO NOT operate appliance unless all panels and access covers are attached correctly.

WARNING

The contents of the grease box(s) must be emptied into a fireproof container at the end of operation each day. Some food particles can spontaneously combust into flames if left soaking in certain oil/shortening materials.

WARNING

It is recommended that this appliance be inspected by a qualified service technician for proper performance and operation on a yearly basis.

WARNING

There is an open flame inside this appliance. The unit may get hot enough to set nearby materials on fire. Keep the area around the appliance free from combustibles.

WARNING

DO NOT supply the appliance with a gas that is not indicated on the data plate. If you need to convert the appliance to another type of fuel, contact your Equipment Supplier or a MagiKitch'n Authorized Service and Parts (ASAP) Company.

TO THE PURCHASER, OWNER AND STORE MANAGER

Please review these warnings prior to posting them in a prominent location for reference.

WARNING

The following symbol is affixed to the appliance to remind users that, in order to safely operate this appliance, it is understood the instruction manual before attempting to operate this appliance.



WARNING

In the event of a power failure turn all controls to the “Off” position and do not attempt to operate this appliance.

WARNING

This appliance is not intended for use by persons (including children) with reduced physical, sensory or mental capabilities, or lack of experience and knowledge, unless given supervision or instruction concerning use of the appliance by a person responsible for their safety.

WARNING

This appliance is intended for professional use only and should be operated by fully trained and qualified personnel.

WARNING

Children should not be in the vicinity of this appliance when it is being operated, cleaned, maintained or serviced nor allowed to play on and/or with the appliance at any time.

WARNING

In North America, gas appliances equipped with, or mounted on equipment stands with casters must be installed with connectors that comply with the Standard for Connectors for Movable Gas Appliances, ANSI Z21.69.CSA 6.16 Latest Edition. This connection should include a quick disconnect device that complies with the Standard for Quick Disconnect Devices for Use With Gas Fuel ANSI Z221.41.CSA 6.9 Latest Edition. In Australia, an appliance equipped with casters and a flexible gas line must be connected to the gas supply with a quick disconnect device that complies with AS 4627 and a restraining cable. The restraining cable must not exceed 80% of the length of the flexible gas line. Hose assemblies for use with cooking appliances must be certified as conforming with AS/NZS 1869 and be Class B or Class D type.

1. INSTALLATION	6
1.1. CHECKING YOUR NEW GRIDDLE	6
1.2. ELECTRICAL CONNECTION(S)	6
1.3. INSTALLATION CLEARANCES	7
1.4. GAS CONNECTION(S)	7
1.4.1. Fuel Type(s)	7
1.4.2. Quick Disconnect Connection	7
1.4.3. Fuel Supply Line and Leak Pressure Testing	7
1.5. VENTILATION AND FIRE SAFETY SYSTEMS	7
1.6. INSTALLATION SETUP	8
1.6.1. Counter Use With Legs	8
1.6.2. Counter Use Without Legs	8
1.6.3. Equipment Stand	9
1.6.4. Leveling Instructions	10
1.7. FINAL GAS CONNECTION	10
1.7.1. Regulator Assembly	10
1.7.2. Gas Settings	12
1.7.3. Gas Table	13
2. OPERATION	14
2.1. LIGHTING INSTRUCTIONS	14
2.1.1. Snap-Action Thermostat Appliances	14
2.1.2. Solid State and Electric Thermostat Appliance	14
2.2. INITIAL STARTUP	15
2.2.1. Griddle Surface Seasoning	15
2.2.2. Surface Temperature Check	15
2.2.3. Shutdown Procedure	15
3. THERMOSTAT CALIBRATION SECTION	16
3.1. SNAP ACTION AND ELECTRIC THERMOSTAT	16
3.2. SOLID STATE THERMOSTAT	16
4. BASIC OPERATION	17
4.1. OPERATIONAL HELPFUL HINTS	17
4.2. SUGGESTED COOKING TIMES AND TEMPERATURES	17
5. CLEANING & MAINTENANCE SECTION	18
5.1. GRIDDLE SURFACE CLEANING, DURING OPERATION HOURS	18
5.2. GRIDDLE SURFACE CLEANING, END OF SHIFT	18
5.2.1. Plain Steel Cooking Surface	18
5.2.2. Chrome Plated Cooking Surface	18
5.3. MONTHLY MAINTENANCE	18
5.3.1. Monthly Preventative Maintenance	18
5.4. ANNUAL/PERIODIC PREVENTATIVE MAINTENANCE AND INSPECTION	19
5.4.1. Safety Evaluation	19
5.4.2. Mechanical Inspection	19
5.4.3. Systems Operation Inspection	19
5.5. VENTILATION HOOD	19
5.6. TROUBLE SHOOTING CHARTS	20
5.6.1. Cooking Performance	20
5.6.2. Operating Performance	20
6. ACCESSORIES	21
6.1. STANDARD	21
6.2. OPTIONAL	21
6.2.1. Service Shelves, Front	21
6.2.2. Cutting Boards	22
6.2.3. Warming Shelves, Rear	23
6.2.4. Equipment Stands	24
6.2.5. Miscellaneous	25
7. NOTES	26

1. Installation

1.1. Checking Your New Griddle

Your new MagiKitch'n appliance has been carefully packed into one crate. Every effort has been made to ensure that it is delivered to you in perfect condition. As you unpack your new appliance, inspect each of the pieces for damage. If something is damaged, DO NOT sign the bill of lading. Contact the shipper immediately; the shipper is only responsible for 15 days after delivery. Check the packing list enclosed with your appliance to ensure that you have received all the parts to the appliance. If you are missing any parts, contact the dealer from whom the appliance was purchased.

Locate the MagiKitch'n Model Number and Serial Number from the information plate on the inside wall, see Figure 1. Write this information and the date the appliance was purchased on the front of this manual.

If you have completed the above steps that are applicable to the appliance you purchased, the appliance is now ready to be installed. Although it may be possible for you to install and set up your new appliance, it is STRONGLY advised that you have this done by qualified service professionals. A qualified professional will ensure that the installation is safe and meets local building and fire codes.

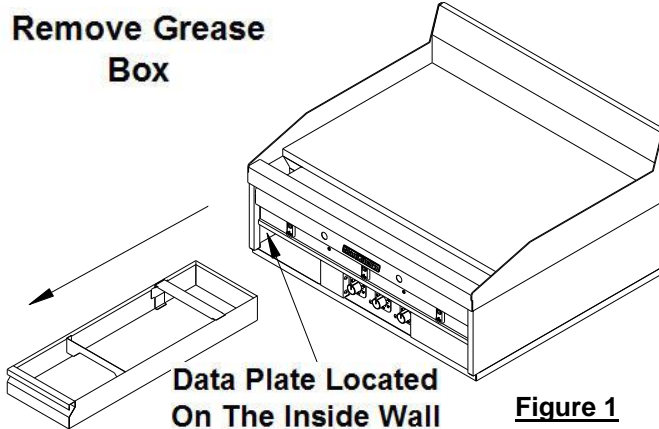

Figure 1

1.2. Electrical Connection(s)

It is advised that this appliance be plugged into a wall receptacle that is controlled by the ventilation control. This will prevent the appliance from being operated without the ventilator on. A schematic is behind the front access panel. The power requirements are listed below.

Electrical Requirements		
	North America	International
Input Voltage	120 Vac 50/60 Hz	220,230, or 240 Vac 50/60 Hz
Current/Control	0.22 Amps	0.11 Amps

CAUTION

Connecting the appliance to an electrical supply other than that indicated on the data plate. may damage the appliance and void the warranty.

WARNING

If the appliance is equipped with a power cord and it is damaged, it must be replaced by a MagiKitch'n Authorized Service and Parts (ASAP) company technician or a similarly qualified person in order to avoid a hazard. A replacement, oil resistant cord must be provided by the manufacturer.

WARNING

The electrical connection used by this appliance must comply with local codes. If there are no local codes that apply, refer to the National Electrical Code (NEC), ANSI/NFPA 70 for installation in the US. In Canada, refer to CSA Standard C22.2 and local codes. In all other cases, refer to local and national codes and regulations.

WARNING

This equipment must be installed so that the plug is accessible unless other means for disconnection from the power supply (e.g. a circuit breaker) is provided.

WARNING

If your appliance uses line current, it is equipped with an oil proof, electrical supply cord with a three-prong safety plug. This is to protect operators from electrical shock hazard in the event of an equipment malfunction. DO NOT cut or remove the grounding (third) prong from this plug; it should be plugged into a properly grounded three-prong receptacle.

1.3. Installation Clearances

Your new MagiKitch'n Griddle needs clearance around it for proper operation. Adequate clearances allow for servicing and proper burner operation. The clearances shown below are for installation in combustible and non-combustible construction. The appliance can be serviced from the front of the unit; however it may need to be pulled away from the wall for access to the gas supply and electrical supply connections. Ensure that all clearances stated on the Data plate and in the table below are strictly followed.

Location	Combustible Construction Inches (Centimeters)	Non-Combustible Construction Inches (Centimeters)
Cabinet Back - NON-CE / CE	6.0 (15.2) / 6.0 (15.2)	6.0 (15.2) / 6.0 (15.2)
Cabinet Sides - NON-CE / CE	2.0 (5.0) / 6.0 (15.2)	0.0 (0.0)

1.4. Gas Connection(s)

Your gas appliance will give you peak performance when the gas supply line is of sufficient size to provide the correct gas pressure. The gas line must be installed to meet the local building codes or National Fuel Gas Code ANSI Z223.1 Latest Edition. In Canada, install the appliance in accordance with CAN/CGA-B149.1 or .2 and local codes. In Australia, install the appliance in accordance with AS/NZS 5601. Gas line sizing requirements can be determined by your local gas company or, in North America, by referring to the National Fuel Gas Code, Appendix C, Table C-4 (for natural gas) and Table C-16 (for propane). The gas line needs to be large enough to supply the necessary amount of fuel to all appliances without losing pressure to any appliance. A properly sized and installed gas line will deliver a supply pressure between 7.0" W.C. (17.4mbars, 1.74kPa) and 10.0" W.C. (24.9mbars, 2.49kPa) natural gas or between 11.0" W.C. (27.4mbars, 2.74kPa) and 13.0" W.C. (32.4mbars, 3.25kPa) for propane to all appliances connected to the supply line, operating simultaneously at full demand. The pressure at the gas valve shall not exceed ½ PSI.

WARNING

NEVER supply the appliance with a gas that is not indicated on the data plate. Supplying incorrect gas will cause improper operation. Contact your Dealer for another gas type for the appliance.

1.4.1. Fuel Type(s)

Each appliance is equipped to work with one type of fuel. The type of fuel with which the appliance is intended to operate is stamped or printed on the data plate, see Figure 1.

CAUTION

NEVER use an adapter to make a smaller gas supply line fit the appliance connection. This may limit proper gas flow for optimum burner operation, resulting in poor performance.

1.4.2. Quick Disconnect Connection

In North America, gas appliances equipped with casters must be installed with connectors that comply with the Standard for Connectors for Movable Gas Appliances, ANSI Z21.69.CSA 6.16 Latest Edition. This connection should include a quick disconnect device that complies with the Standard for Quick Disconnect Devices for Use With Gas Fuel Appliances ANSI Z21.41.CSA 6.9 Latest Edition. In Australia, an appliance equipped with casters and a flexible gas line must be connected to the gas supply with a quick disconnect device that complies with AS 4627 and a restraining cable. The restraining cable must not exceed 80% of the length of the flexible gas line. The restraining device should be attached to the appliance at the back panel.

1.4.3. Fuel Supply Line and Leak Pressure Testing

The fuel supply system must be tested before the appliance is used. If the fuel line is going to be tested at a pressure greater than ½ PSIG (3.45 kPa, 34.5 mbar), insure that that appliance is disconnected from the fuel line. If the fuel line is to be tested at a pressure equal to or less than ½ PSIG (3.45 kPa, 34.5 mbar), the appliance can be connected during the test, but the unit's gas valve must be shut. Test all gas line connections for leaks with a solution of soap and water when pressure applied.

1.5. Ventilation and Fire Safety Systems

Your new gas appliance must have proper ventilation to function safely and properly. Exhaust gas temperatures can reach as high as 1000°F (538 °C). Therefore, it is very important to install a fire safety system. Your ventilation system should be designed to allow for easy cleaning. Frequent cleaning of the ventilation system and the appliance will reduce the chances of fire. In North America, additional information can be obtained from CSA International, 8501 East Pleasant Valley Rd., Cleveland, OH 44131. In Australia, the ventilation system must comply with AS/NZS 5601.1.

CAUTION

Excessive ventilation causes drafts, which will interfere with the operation of the appliance. Leave at least 18 inches of open space between the flue opening and the intake of the exhaust hood.

CAUTION

Ensure that your ventilation system does not cause a down draft at the appliance's flue opening. Down drafts will not allow the appliance to exhaust properly and will cause overheating which may cause permanent damage. Damage caused by down drafts will not be covered under equipment warranty. NEVER allow anything to obstruct the flow of combustibles or ventilation exiting the appliance flue.

CAUTION

NEVER connect the blower directly to the flue opening(s). The direct flow of air will cause poor temperature recovery, poor ignition and inefficient operation of the appliance and could extinguish the pilot(s).

1.6. Installation Setup

The installation of this appliance **MUST** conform to local codes. In the absence of local codes in North America, the installation must conform with the National Fuel Gas Code, ANSI Z223.1/NFPA 54 or the Natural Gas and Propane Installation Code CSA B149.1 as applicable. In Australia, the appliance must be installed in compliance with AS/NZS 5601 (current revision). To Start uncrate appliance and locate installation accessories.

1.6.1. Counter Use With Legs

CAUTION

To prevent equipment damage, **DO NOT** tilt your MagiKitch'n griddle on only two legs, or on its sides.

(See Figure 2) A set of 4" (10.2cm) legs is shipped with the appliance (unless appliance was specifically ordered without legs). A threaded insert for the leg bolt is located near each corner of the bottom appliance. Raise the appliance to allow legs to be screwed tightly into inserts. The appliance can be leveled by adjusting the feet at the bottom of the leg assembly. This can be done by turning the foot in or out to lower or raise each corner as needed.

NOTICE

4" Legs should not to be used with the Equipment Stand.

1.6.2. Counter Use Without Legs

See Figure 3). The appliance must be sealed to the counter to comply with applicable sanitation standards. A bead of silicone sealant, approximately ½ inch (13 mm) wide, is to be applied to the bottom of the unit approximately ¼" (7 mm) in from the front, back and side edges. We suggest Dow Corning ® 732 silicone 'RTV' adhesive sealant or equivalent. (See NSF Basic Criteria C-2 for details).

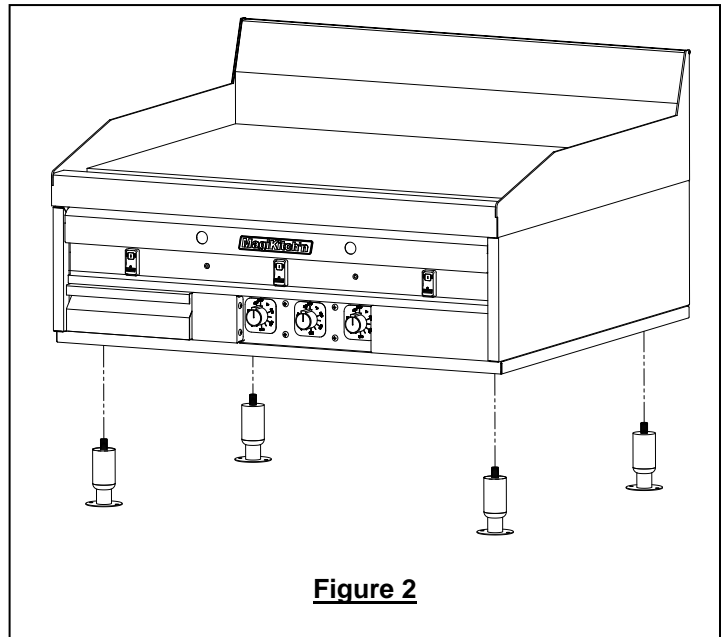
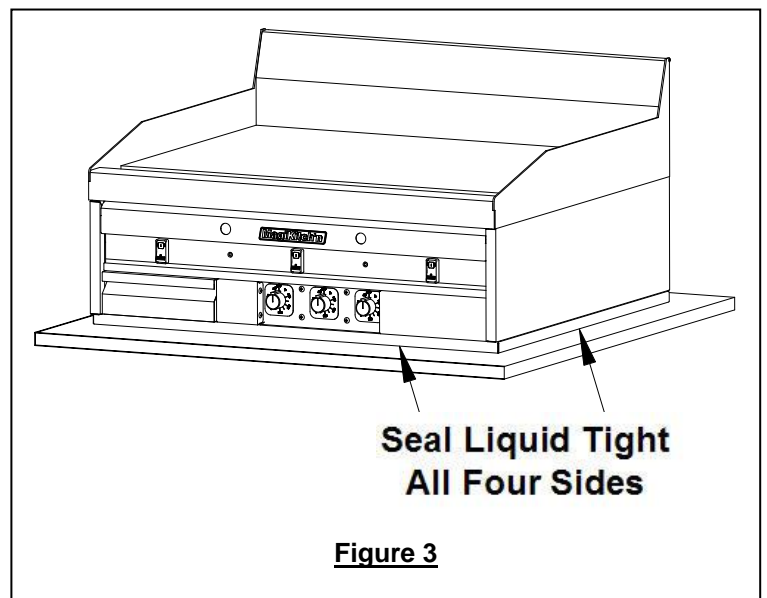

Figure 2



**Seal Liquid Tight
All Four Sides**

Figure 3

WARNING

DO NOT alter or remove structural material on the appliance to accommodate placement under a ventilation hood.

1.6.3. Equipment Stand

ATTENTION

Rear mounting brackets should be installed to the Equipment Stand prior to placing griddle on the stand.

IMPORTANT

Install the griddle so that the locking casters are at the *front of the unit*. The casters should be **LOCKED** before the unit is placed into operation.

(See Figure 4). To mount the griddle to the stand, locate joining kit supplied with stand. The joining kit should include (2) rear mounting brackets, and (4) 1/2" (13mm) mounting bolts. To mount the griddle to the equipment, perform the steps on the following page:

IMPORTANT

The appliance must be level to perform properly. Failure to level unit may result in improper performance of the appliance.

NOTICE

Larger models have 6 threaded receiving holes, but require only the four 1/2" (13mm) bolts on each corner to mount the griddle.

1. Remove (4) existing 1/4-20 nuts and bolts from the rear corners of the equipment stand.
2. Align the 2 bolt holes on the rear corners of the stand with the 2 bolt holes on the rear mounting brackets. Orient the brackets as shown in Figure #4 on this page.
3. Install the provided rear mounting brackets (2) to the rear corners by using the existing 1/4-20 hardware that were removed in step 1, tighten securely.
4. Carefully place the griddle on the equipment stand.
5. Once the griddle is on the stand, position the griddle on the stand so that the front edge of the base is flush with the front of the equipment stand. If the griddle is the only appliance to be mounted on the stand, then both sides of the griddle should be flush with the sides of the equipment stand.
6. When positioned properly, the threaded receiving holes in the griddle base should be aligned with mating clearance holes at the front of the equipment stand, and with the clearance holes in the rear mounting brackets. Install the provided 1/2" (13mm) bolts and tighten securely.

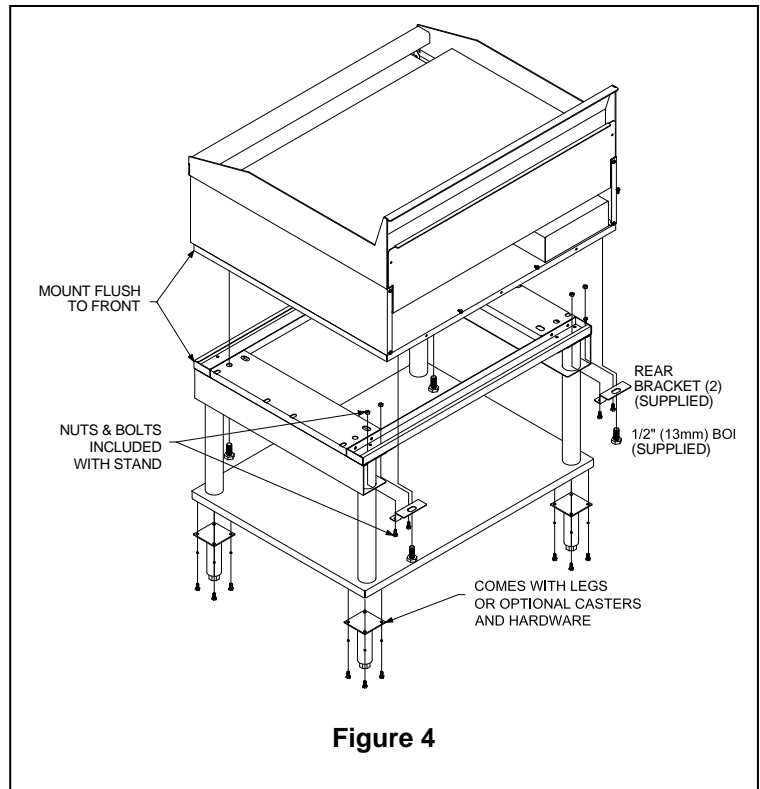

Figure 4

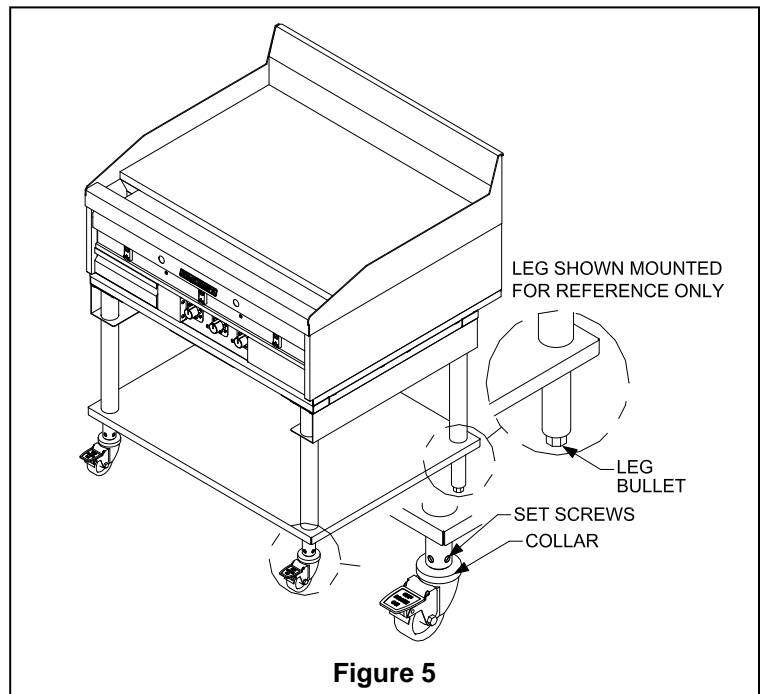

Figure 5

1.6.4. Leveling Instructions

NOTICE

Equipment stands are shipped from the factory with the legs or casters set to the minimum height adjustment. Units should be leveled at time of installation, failure to do so could cause the griddle to operate improperly.

1. Identify the corner of the stand that needs to be adjusted, remove the weight load from the corner to be leveled.
2. **Legs-** using a wrench, or pliers turn the leg bullet, See Figure 5, CCW to raise the height of the equipment stand. There is $\frac{1}{2}$ " (13mm) to $\frac{3}{4}$ " (19mm) of adjustment.
Casters- Using a Flat Head screwdriver, loosen the set screws of the caster to be leveled, See Figure 5. Turn the collar of the caster CCW to raise the height of the equipment stand. There is $\frac{3}{4}$ " (19mm) of adjustment.
After leveling adjustment is complete, re-tighten set screws.
3. Check the levelness of the equipment, if necessary Repeat steps 1 and 2.

NOTICE

This appliance may only be installed with casters provided by the manufacturer. When installed with casters in North America, a gas connection complying with ANSI Z21.69/CGA-6.16 and a quick disconnect device complying with ANSI Z21.41/CAN 1-6.9. It must also be installed with a restraining device to guard against putting any strain on the gas connections when the unit is moved. In Australia the quick disconnect device must comply with AS4627. The restraining device must not exceed 80% of the length of the flexible gas line.

1.7. Final Gas Connection

A properly installed gas supply system will deliver adequate pressure, between 7 and 8 inches w.c. (1.75-2.0 kPa, 17.5-20.0 mbars) for natural gas, or 11 to 12 inches w.c. (2.7-3.0 kPa, 27.0-30.0 mbars) for propane to all appliances connected to the line, operating at full demand.

1.7.1. Regulator Assembly

An adequate gas supply is important for the appliance to operate properly. Undersized lines or low-pressures will restrict the volume of gas required for satisfactory performance. A steady supply pressure between 7" and 8" w.c. (1.75-2.0 kPa, 17.5-20 mbars) for natural gas or 11" to 12" (2.7-3.0 kPa, 27-30 mbars) for propane gas is required. With all gas appliances operating simultaneously, the manifold pressure on all gas appliances should not show any appreciable drop. Fluctuations of more than 25% on natural and 10% on propane gas will create pilot problems and affect burner operating characteristics. Contact your gas company for correct supply line sizes. After connection, a certified gas service agent should check all newly installed equipment for correct gas pressure. The unit should be connected ONLY to the type of gas for which it is equipped. Check the gas type on the Data plate; see section 1.1 of this manual.

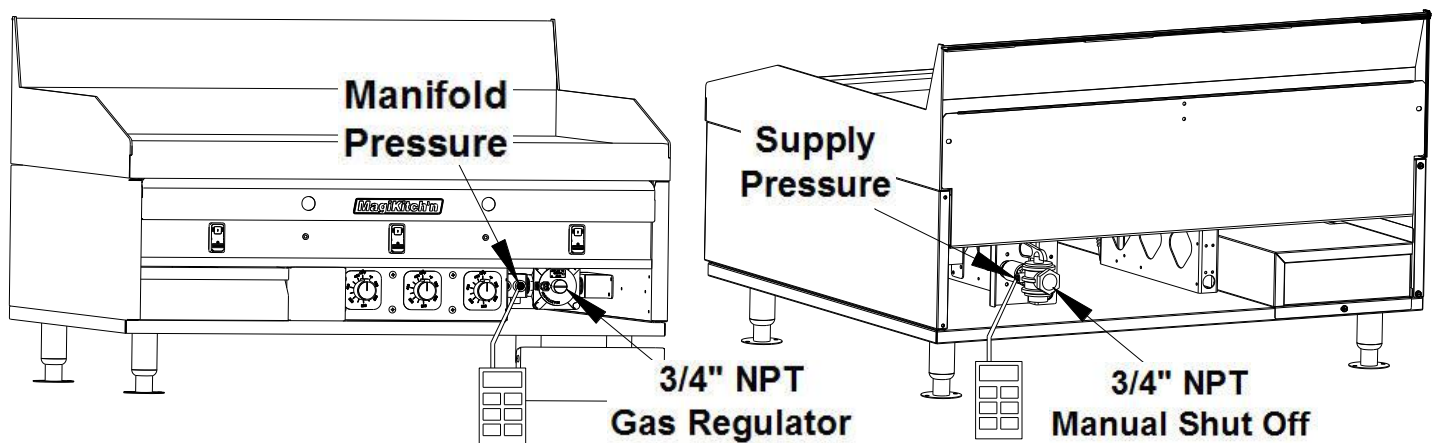

Figure 6, Matchless Ignition Regulator System

1. In most cases the gas input regulator for your new appliance has been installed at the factory, See Figures 6 & 6a depending on the model of your appliance for the location of the regulator and the manual shut off valve. **Note:** For Australian models the regulator is supplied as a separate item. This will allow the installer to choose their method of installation in accordance with AS/NZS 5601. The example in Figure 6a shows one possible method of attachment. Using a regulator other than the one supplied with the unit will void the warranty.
2. The manifold pressure must be maintained at the pressure marked on the Data plate. The manifold pressure reading is taken at the 1/8" NPT coupling located behind the lower front panel next to the gas regulator, see Figure 6 & 6a. To check the supply pressure to the appliance use the pressure test point supplied on the manual shut off valve, also see Figure 6 & 6a.
3. Use pipe joint compound that is suitable for use with LP gas on all threaded connections.
4. Turn off all thermostats.
5. Turn on gas supply and check all connections for leaks using ONLY a leak checking fluid or soapy water. NEVER use an open flame to check for gas leaks.
6. Provisions must be made for adequate air supply for both the appliance and room occupants.
7. Keep area in front of unit clear of obstructions that may block flow of combustion and/or ventilation air.

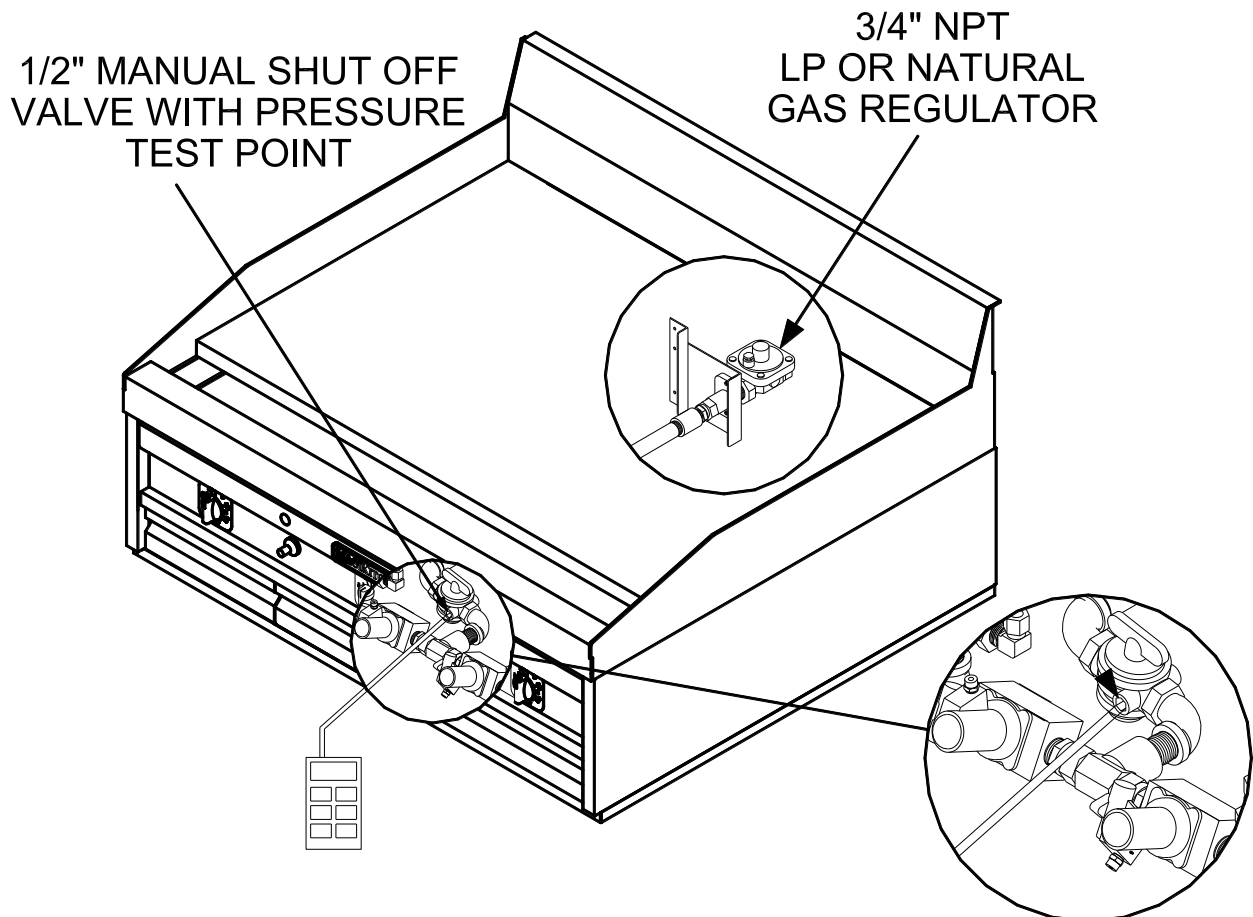

Figure 6a, Snap Action Regulator System



1.7.2. Gas Settings

Orifices are sized to provide proper gas flow to the rated BTU/hr for each model. Regulator pressure must be measured and adjusted before the unit goes into service, following installation and when operational performance is in question. The manifold and supply pressure readings are taken at the pressure test points provided, see Figure 6 & 6a.

Gas Type	BTU/hr(kW) per Burner	Manifold Pressure (All Models)
Natural	15,000 (4.4)	4.0" WC (10.1cm) [10 mbar]
Propane	15,000 (4.4)	10.0" WC (25.4cm) [25 mbar]

WARNING

Ensure that the appliance can get enough air to keep the flame burning correctly. If the flame is starved for air, it can give off a dangerous carbon monoxide gas. Carbon monoxide is a clear odorless gas that can cause suffocation.

Netherlands

This unit has been set for the appliance category K (I2K) and is suitable for the use of G and G+ gas distribution according to the specifications as shown in the NTA 8837: 2012 Annex D with a Wobbe index from 43.46 to 45.3 MJ/m³ (dry, 0°C, above value) or from 41.23 to 42.98 (dry, 15°C, upper value). This unit can also be converted and / or adjusted again for the appliance category E (I2E) This therefore means that the device "is suitable for G+ gas and H-gas, it is demonstrably suited for G+ gas and demonstrable is suitable to H-gas "within the meaning of the Decision of May 10, 2016 amending the Decree on gas appliances"

1.7.3. Gas Table

Applicable Countries	Model	Fuel Type	Gas	Appliance Category	Gross Input (kW)	Net Input (kW)	Supply Pressure (mbar)	Burner Pressure (mbar)	Burner Orifice	Pilot Orifice (code)	Governor	Nominal Gas Rate (m ³ /hr)				
AT, BG, CH, CZ, DK, EE, FI, GB, GR, HU, IE, IT, LT, LV, NO, PL, PT, RO, ES, SI, SK, SE, TR	MKG24	Nat	G20	I _{2H}	17.6	15.8	20	10	1.85 mm	N22	YES	1.7				
LU				I _{2E}												
FR				I _{2ESI}												
BE			G20/G25	I _{2E+}									20/25	2.1 mm	YES	1.7/2.0
DE			G20/G25	I _{2ELL}												
NL			G25-G25.3	I _{2L - I_{2EK}}												
BG, CH, CY, CZ, FR, DE, GB, GR, HU, IE, IT, LU, MT, NL, PL, PT, RO, ES, SI, SK, TR	LP	G31	I _{3P}	16.2	50/37	25.4	1.10 mm	LP16	YES	0.7						
AT, BG, CH, CZ, DK, EE, FI, GB, GR, HU, IE, IT, LT, LV, NO, PL, PT, RO, ES, SI, SK, SE, TR	MKG36	Nat	G20	I _{2H}	26.4	23.8	20	10	1.85 mm	N22	YES	2.5				
LU				I _{2E}												
FR				I _{2ESI}												
BE			G20/G25	I _{2E+}									20/25	1.85/2.1 mm	NO	2.5/2.9
DE			G20/G25	I _{2ELL}												
NL			G25-G25.3	I _{2L - I_{2EK}}												
BG, CH, CY, CZ, FR, DE, GB, GR, HU, IE, IT, LU, MT, NL, PL, PT, RO, ES, SI, SK, TR	LP	G31	I _{3P}	24.3	50/37	25.4	1.10 mm	LP16	YES	1.0						
AT, BG, CH, CZ, DK, EE, FI, GB, GR, HU, IE, IT, LT, LV, NO, PL, PT, RO, ES, SI, SK, SE, TR	MKG48	Nat	G20	I _{2H}	35.1	31.6	20	10	1.85 mm	N22	YES	3.3				
LU				I _{2E}												
FR				I _{2ESI}												
BE			G20/G25	I _{2E+}									20/25	1.85/2.1 mm	NO	3.3/3.9
DE			G20/G25	I _{2ELL}												
NL			G25-G25.3	I _{2L - I_{2EK}}												
BG, CH, CY, CZ, FR, DE, GB, GR, HU, IE, IT, LU, MT, NL, PL, PT, RO, ES, SI, SK, TR	LP	G31	I _{3P}	32.3	50/37	25.4	1.10 mm	LP16	YES	1.3						
AT, BG, CH, CZ, DK, EE, FI, GB, GR, HU, IE, IT, LT, LV, NO, PL, PT, RO, ES, SI, SK, SE, TR	MKG60	Nat	G20	I _{2H}	43.9	39.5	20	10	1.85 mm	N22	YES	4.2				
LU				I _{2E}												
FR				I _{2ESI}												
BE			G20/G25	I _{2E+}									20/25	1.85/2.1 mm	NO	4.2/4.9
DE			G20/G25	I _{2ELL}												
NL			G25-G25.3	I _{2L - I_{2EK}}												
BG, CH, CY, CZ, FR, DE, GB, GR, HU, IE, IT, LU, MT, NL, PL, PT, RO, ES, SI, SK, TR	LP	G31	I _{3P}	40.4	50/37	25.4	1.10 mm	LP16	YES	1.7						
AT, BG, CH, CZ, DK, EE, FI, GB, GR, HU, IE, IT, LT, LV, NO, PL, PT, RO, ES, SI, SK, SE, TR	MKG72	Nat	G20	I _{2H}	52.7	47.5	20	9	1.85 mm	N22	YES	5.0				
LU				I _{2E}												
FR				I _{2ESI}												
BE			G20/G25	I _{2E+}									20/25	1.85/2.1 mm	NO	5.0/5.8
DE			G20/G25	I _{2ELL}												
NL			G25-G25.3	I _{2L - I_{2EK}}												
BG, CH, CY, CZ, FR, DE, GB, GR, HU, IE, IT, LU, MT, NL, PL, PT, RO, ES, SI, SK, TR	LP	G31	I _{3P}	48.5	50/37	25.4	1.10 mm	LP16	YES	2.0						

2. Operation

Ensure that a proper installation has been performed on the appliance and that all warnings, cautions, and notices contained in this manual have been read, understood and adhered to before proceeding.

2.1. Lighting Instructions

2.1.1. Snap-Action Thermostat Appliances

1. Turn all thermostat knobs to the “OFF” position.

2. Open front door of the griddle, turn the manual gas shut off valve to the “ON” position. See Figure 6.

3. Press and hold the left or right **RED** pilot button, see detail Method A at right, and light the left or right pilot by depressing the Piezo ignition control, look through the pilot hole to see the pilot ignites. With pilot burning, keep the **RED** pilot knob depressed for 45 seconds or until pilot remains lit automatically. If the Piezo ignition control does not light the pilot(s), a flame source can be used to light the pilot(s) through the pilot holes provided in the front panel of the appliance.

4. Repeat steps 1, 2, and 3 for all remaining pilots.

5. Operate thermostats by turning knobs clockwise to the desired temperature and insure that burners light properly by looking through the pilot holes provided in the front panel.

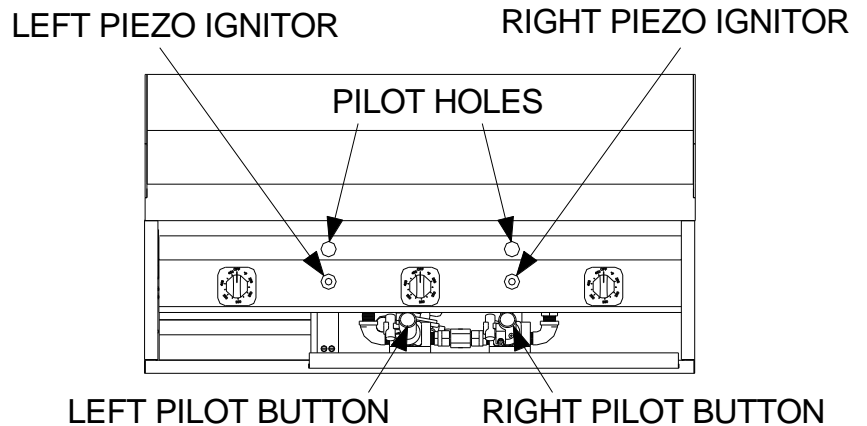

2.1.2. Solid State and Electric Thermostat Appliance

1. Turn all thermostat knobs to the “OFF” position, or the lowest possible temperature setting.

2. Turn the Manual gas shut off valve to the “ON” position, this valve is located at the rear of the unit, see Figure 6a. To open the valve to allow gas flow the handle should be in line with the manual shut off valve.

3. Turn the **RED** “I/O” switch to the “I” (ON) position for all desired Thermostats to be operated, See Figure 7. When the Pilot ready (Yellow) light illuminates, the pilot(s) are ready to operate the main burners.

4. Repeat steps 1, 2, and 3 for all thermostat controls to be operated.

5. Operate thermostats by turning knobs clockwise to the desired temperature and insure that burners light properly by looking through the pilot viewports provided in the front panel. The **RED** “I/O” switch will illuminate when the thermostat calls for heat.

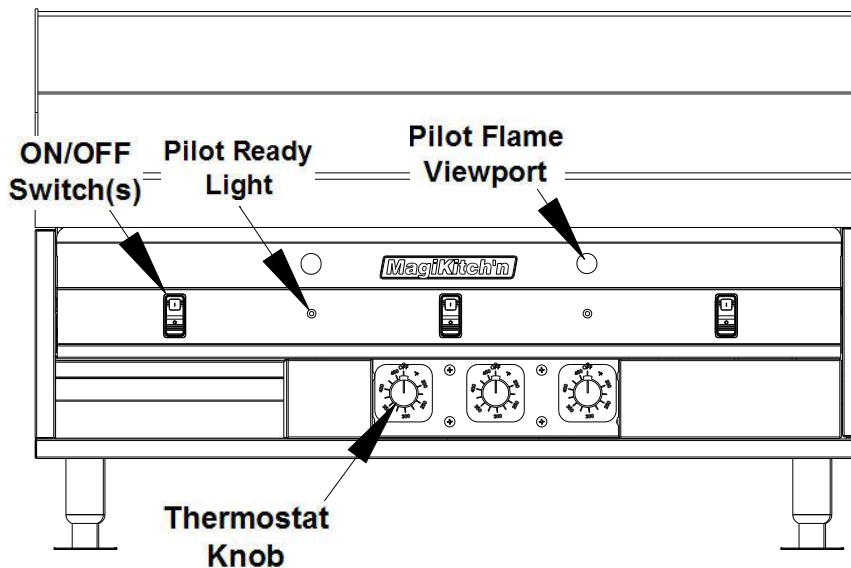

Figure 7

CAUTION

If Pilot Ready light(s) does not illuminate, Turn all Thermostat "I/O" switches for that pilot to "O" (OFF), wait five minutes before attempting to re-light.

WARNING

If the gas supply and/or the electrical power is interrupted, or if pilot(s) extinguish, turn the thermostat knobs and the gas shut off valve to the "OFF" position and wait five (5) minutes before attempting to re-light the pilot. Do not attempt to operate this appliance during a power failure.

2.2. Initial Startup**NOTICE**

New griddles should be carefully tempered and cared for in order to avoid possible damage.

Wipe the griddle surface clean. A mild soapy water solution may be used to clean the surface, be sure to rinse cooking surface thoroughly with fresh water to eliminate any soap residue. It is also important to wipe the griddle surface and surrounding areas to dry up any standing water. Never allow water on a hot griddle surface.

Seasoning is not required on a Chrome Plated Cooking surface, but the following procedure may be performed to improve the non-stick qualities of the chrome plated cooking surface.

2.2.1. Griddle Surface Seasoning

1. To season the griddle, Light all pilots and turn all the thermostat controls to 200°F, (93°C). As the unit heats up to 200°F, (93°C), apply a light film of cooking oil or beef suet over the entire cooking surface, wiping off any excess build up. This step may be repeated as necessary to apply an even coating on the griddle surface. Seasoning will help create and maintain a non-stick cooking surface on your griddle.
2. Allow the seasoned surface to idle for one hour at 200°F, (93°C), Then set the thermostats to your desired cooking temperature, once your griddle surface has reached temperature, apply another coating of seasoning oil, wiping off any excess that may cause build up.

2.2.2. Surface Temperature Check

1. If available, place grill surface thermometer over each thermostat sensing probe 12", (30.5cm), from the front edge of the griddle surface, See Figure 8 below. The sensing probes are located in line with the thermostat knobs on snap action models, or the ON/OFF switch(s) on matchless ignition models. Align your measuring device with the respective location on your appliance and monitor the temperature at all the controls that are to be adjusted.
2. Heat the griddle up to the desired cooking temperature; check the surface temperature reading on the grill thermometer. If necessary, adjust the thermostats that control any area of the surface that are not within $\pm 15^\circ\text{F}$ ($\pm 8.3^\circ\text{C}$) of the thermostat setting. The procedure for adjusting the thermostats is in Section 3.

2.2.3. Shutdown Procedure

1. Turn thermostat knobs to the "OFF" position, or the lowest possible temperature setting.
2. On matchless ignition models turn "I/O" Switch to "O" position.
3. Close manual gas valve shut off.
4. Allow griddle surface to cool normally.

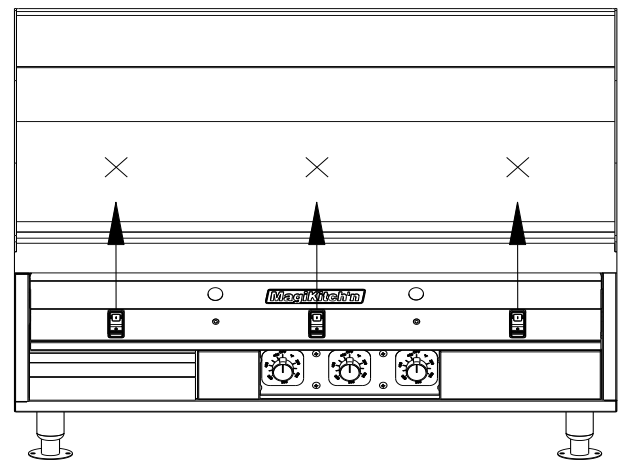

Figure 8

3. Thermostat Calibration Section

Each control typically operates a pair of burners with a Snap action, Electric or Solid State. The controls were set at the factory. However, if the griddle's surface temperature varies greatly from the setting on the thermostat knob, adjust the thermostat using the following procedure:

3.1. Snap Action and Electric Thermostat

- 1 Light pilots as described in section(s) 2.1.1 and 2.1.2.
- 2 Turn all the control knobs to the desired temperature setting.
- 3 Wait 30 minutes (or 1 hour if griddle was cold) for surface to stabilize.
- 4 Place a reliable Griddle surface thermometer, or test instrument thermocouple, able to register 300°F (149°C), in the location above the thermostat being calibrated as described in section 2.2.2. Check the temperature every 5 minutes until the temperature stabilizes and does not change by more than 30°F (16.5°C) over a 15 minute span.
- 5 If the average temperature over any burner set is not within +/-15°F (8.3°C) of the knob setting, adjust the corresponding thermostat. This is done by removing the knob, holding the thermostat knob stem, see Figure 9, (**do not allow the stem to turn or the temperature setting will not be accurate**), then turn the adjustment screw located within the center of the stem in small increments. Turn this screw counter clockwise to increase the temperature, and clockwise to decrease the temperature.
- 6 Check the temperature after 15 minutes and repeat adjustment as needed until the correct temperature is indication on the measuring instrument.

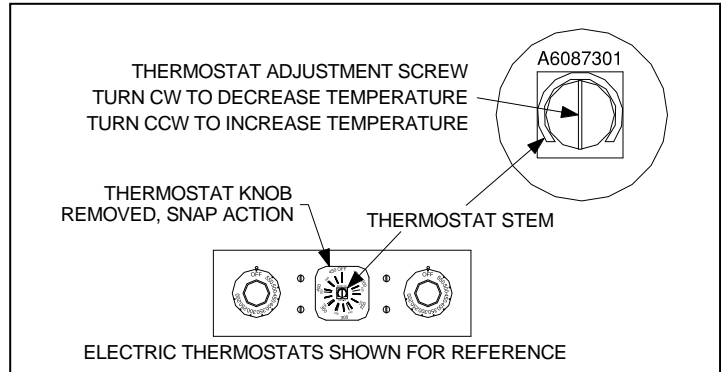

Figure 9

NOTE:

Hold the knob firmly when loosening or tightening the 5/16" (8mm) locknut that holds the knob onto the thermostat shaft to keep from changing temperature settings.

3.2. Solid State Thermostat

- 1 Light pilots as in section 2.1.1.
- 2 Set all the thermostat control knobs to the desired cooking temperatures.
- 3 Wait 30 minutes (or 1 hour if griddle was cold) for surface temperature to stabilize.
- 4 Place a reliable Grill surface thermometer, or test instrument thermocouple, (able to register 550°F (288°C)), in the location above the thermostat being calibrated described in section 2.2.2.
- 5 Check the temperature at each location every 5 minutes, and repeat until the temperature stabilizes and does not change by more than 20°F (11.0°C) over a 15 minute time period. You will need to remember the average temperature for the following steps.
- 6 If the thermostat is not operating within 10°F (5.5°C) of the temperature set point, you may need to adjust the control.
- 7 To adjust the control, carefully remove the cap on the thermostat knob, See Figure 9a, set cap aside.
- 8 While holding the knob, loosen the 5/16" (8mm) nut on the thermostat shaft, (**DO NOT REMOVE**).
- 9 Once the knob is loosened from the thermostat shaft, rotate the knob so the white indicator line of the knob is aligned with the actual temperature that you monitored in step 5.
- 10 Re-tighten the 5/16" (8mm) nut while holding the knob in position, (do not allow the stem to turn or the temperature setting will not be accurate).
- 11 Set the control to the desired temperature and monitor as in step 5, readjust temperature control as needed until desired temperature is achieved.
- 12 Make sure the control knob is secured, replace cap.

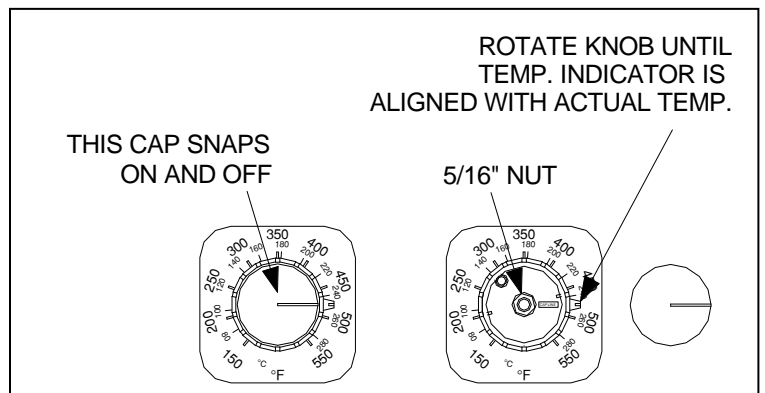

Figure 9a

4. Basic Operation

4.1. Operational Helpful Hints

1. Each thermostat controls 12" (30.5cm) of griddle surface; whenever possible use the leftmost or rightmost thermostats for the lowest cooking temperatures. The adjacent thermostats set at higher temperatures will effect centrally located thermostats.
2. For quicker thermostat response during heavy loading of the griddle, load product directly over the thermostat sensing probe. For slow periods load product to one side of the sensing probe to limit possible overheating of unused griddle surface.
3. Whenever possible, rotate the location of where product is cooked, this will keep the entire 12" (30.5cm) of the controlled area at a more even temperature.
4. If any product sticking occurs, apply a thin coat of cooking oil to the surface before loading product.
5. When using spatulas or scrapers, it is **Highly Recommended** that the corners of the tools never strike the griddle surface with any force. This could cause damage to the surface that could collect food particles, and make it difficult to clean.

4.2. Suggested Cooking Times And Temperatures

NOTICE

The times and temperatures in this chart are suggestions only. Your experience with your own menu items will be your best guide to achieving the best food product.

<i>Product</i>	<i>Temperature</i>	<i>Time</i>
Breakfast Items		
Pancakes	375°F (191°C)	2 Minutes
French Toast	400°F (204°F)	4-5 Minutes
*Breakfast Potatoes	375°F-400°F (191°C-204°C)	15-20 Minutes
Eggs		
Scrambled	300°F (149°C)	3-4 Minutes
Sunny Side Up	225°F-300°F (107°C-149°C)	3-4 Minutes
Over Easy	250°F-300°F (121°C-149°C)	2-3 Minutes
Over Hard	225°F-300°F (107°C-149°C)	3-4 Minutes
Breakfast Meats		
Sausage, Link and Patty	350°F (177°C)	3 Minutes
Bacon	350°F (177°C)	2-3 Minutes
Canadian Bacon	350°F (177°C)	2-3 Minutes
Ham Steaks	375°F (191°C)	3-4 Minutes
Broiled Ham	375°F (191°C)	2 Minutes
Ham, Pre-Cooked	375°F (191°C)	2 Minutes
Fish		
Salmon	350°F (177°C)	6-8 Minutes
Hamburgers		
2 Patties per Lb.	350°F (177°C)	6-8 Minutes
4 Patties per Lb.	350°F (177°C)	4-6 Minutes
6 Patties per Lb.	350°F (177°C)	3-4 Minutes
Steaks, Etc.		
1/2"-3/4" Thick, Medium	375°F (191°C)	5-7 Minutes
3/4"-1" Thick, Medium	375°F (191°C)	8-10 Minutes
Beef Tenderloin	400°F (204°F)	3-4 Minutes
Sandwiches, Etc.		
Grilled Cheese	375°F (191°C)	3-4 Minutes
Hot Dogs	325°F (163°F)	2-3 Minutes

*Based on cubed potatoes brought to a boil then cooled prior to finishing on griddle. To reduce burning and sticking of the potatoes, coat the griddle surface with vegetable oil and turn potatoes frequently.

5. Cleaning & Maintenance Section

5.1. Griddle Surface Cleaning, During Operation Hours

1. Keep the griddle surface clean to prevent sticking and poor food product quality.
2. Scrape the griddle plate regularly through out the day with a scraper intended for your type of griddle surfaces to remove all surface grease and food debris.

NOTICE

Do not use Grill Bricks, Grill Screens, or any other type of abrasive material on your MagiKitch'n Chrome Griddle Surface. USING ABRASIVE MATERIALS WILL VOID YOUR WARRANTY.

3. Clean and wipe out grease chutes.
4. Wipe down the exterior with a clean rag or towel to keep grease and food debris from building up on the stainless steel exterior, thermostat controls and switches.
5. At the end of the daily operation hours a degreaser, or stainless steel cleaner can be used to wipe down all the exterior surfaces. Care should be taken to rinse any cleaning solvent residue from any surfaces that may come in contact with food.
6. Remove and empty grease box(es) of any and all debris, also wipe down the inside of the grease box compartment for food particles that may have come free from the grease box.

NOTICE

The grease box is designed to contain grease run off from the griddle surface. The grease box should NEVER be allowed to overfill, and should be emptied accordingly, and grease disposed of properly.

5.2. Griddle Surface Cleaning, End Of Shift

NOTICE

Wear protective gloves and clothing when cleaning the appliance, HOT Surfaces may cause personal injury.

5.2.1. Plain Steel Cooking Surface

1. Scrape griddle surface completely with a scraper to remove grease and food debris.
2. Use a grill brick or grill screen to clean any heavy build up of carbon from the griddle surface. Never use steel wool pads, small fibers may be left behind on the cooking surface.
3. When griddle surface is cool, Clean the cooking surface with a solution of water and Magi Kleans'r, or similar type non-abrasive, non-caustic cleaners that are approved for stainless steel.
4. When the cooking surface is cleaned of all foreign debris, rinse all surfaces completely with clean water and wipe dry with a clean towel.
5. It may be necessary to season the grill again after this cleaning.

5.2.2. Chrome Plated Cooking Surface

1. Scrape griddle surface completely with supplied scraper to remove grease and food debris.

NOTICE

Do not use Grill Bricks, Grill Screens, or any other type of abrasive material on your MagiKitch'n Chrome Griddle Surface. USING ABRASIVE MATERIALS WILL VOID YOUR WARRANTY.

2. When griddle surface is cool, Scrub the Chrome surface with the supplied palmetto cleaning brush and cool water.
3. Shine the Chrome griddle cooking surface with Magi Kleans'r, water and a soft cloth.
4. Rinse with clean water and wipe away any residue with a dry cloth.

5.3. Monthly Maintenance

NOTICE

Regular maintenance of your MagiKitch'n griddle is Recommended to keep the appliance operating properly.

5.3.1. Monthly Preventative Maintenance

Food debris and grease can buildup in and around the griddle. Performing the monthly preventative maintenance steps below will keep your equipment safe and at peak performance. If you are producing high quantities of grilled foods, it may be necessary to clean these components more than once a month

- ✓ Use a grill surface thermometer to make sure thermostats are operating properly.
- ✓ Visually check that the pilot(s) flame(s) are strong and light the main burners properly.
- ✓ Visually check the appearance of the main burners, all burners should have a nice blue flame.

- ✓ Make sure that all gas connections have not been tampered with or damaged, check for leaks with a soapy water solution. **Never use an open flame to check for leaks.**
- ✓ Check to see that the flue exhaust area has no food debris, or blocked in any way. Never allow the flue to become excessively dirty. The flue being free of obstruction is imperative to proper burner operation.
- ✓ Check to see that the ventilation hood and make up air systems are working properly. Any make up air system should not be directed as to impede the flow of combustion air to the griddle, or flue exhaust from the griddle.
- ✓ Inspect griddle surface for any visible damage.
- ✓ Inspect exterior cabinet for damage, loose parts, or sharp edges.
- ✓ Check the function of all controls, lights, and switches.

5.4. Annual/Periodic Preventative Maintenance and Inspection

This section should ONLY be performed by a qualified service technician as part of a regular kitchen maintenance program. This inspection should take place a minimum of once a year by an Authorized Service Technician recommended by MagiKitch'n. It may be necessary perform this inspection more than once a year.

5.4.1. Safety Evaluation

- ✓ Check all gas connections, and verify that the griddle retention/lanyard system is in place.
- ✓ Check for food debris and grease migration in and around the cabinet of the appliance.
- ✓ Check legs/casters, and ensure all nuts and bolts are secured. (If Equipped)
- ✓ Check the power cord and plug.
- ✓ Check all exposed wiring connections, switches and indicator lights.

5.4.2. Mechanical Inspection

- ✓ Check griddle surface for damage, rust, and any cracks in the chrome plating if applicable.
- ✓ Check grease box for leaks.
- ✓ Check for grease and water migration, clean as necessary.
- ✓ Check ventilation hood drain cup and filters, clean as necessary.
- ✓ Check flue for foreign debris and hood down draft currents.
- ✓ Check for loose parts.
- ✓ Check for missing parts and fasteners, replace as necessary.

5.4.3. Systems Operation Inspection

- ✓ Check incoming gas pressure when all gas appliances are operating.
- ✓ Check burner manifold gas pressure; adjust as necessary to Data plate information.
- ✓ Check Ignition system and pilot flame, clean and adjust as necessary.
- ✓ Matchless ignition units inspect spark gap and spark electrode for damage.
- ✓ Check and clean vent opening on manual shut off valve.
- ✓ Check main gas valves for mechanical and electrical functionality.
- ✓ Check all wire terminations, check for broken, or frayed wires.
- ✓ Check temperature calibration.
- ✓ Check thermostat operation and features for proper operation.
- ✓ Verify all components are in good physical condition.
- ✓ Ensure that all components are clean, and do not have any grease or water damage.

5.5. Ventilation Hood

Proper ventilation hood operation is very important for the correct operation of this appliance and the safety of personnel. The ventilation hood should be inspected at the time of installation of this appliance to insure that it will operate properly in conjunction with the appliance. A regular schedule of examination, in accordance with ANSI/NFPA 96 latest edition and/or local codes must be followed.

Cleaning & Maintenance

MKG Series Gas Griddle



5.6. Trouble Shooting Charts

The following charts may help to eliminate any basic operational problems that you may be experiencing with your appliance. Locate the problem on the left side of the chart, and cross-reference with the possible cause. Once the problem has been identified take the appropriate action to rectify the problem.

5.6.1. Cooking Performance

If you are having poor cooking performance or any inconsistencies in product quality, please refer to the following chart for help.

		Possible Cause						
		Heat Set Too High	Moisture In Food Turning To Steam	Griddle Surface Dirty Or Un-Seasoned	Cooking Times Too Short	Product Shelf Life Expired	Improperly Stored Product	Excessive Oil Or Grease On Griddle Surface
P r o b l e m	Excessive Smoke From Fat	X	X					
	Product Sticking	X		X	X			
	Product Edges Burning	X		X	X			
	Product Centers Underdone	X				X		
	Greasy Or Un-desirable Flavor						X	X
	Grease Build Up On Griddle Surface	X		X				X

5.6.2. Operating Performance

The following chart may help to diagnose any operational issue you may be experiencing with your appliance. Some issues may **REQUIRE** that a qualified service technician perform the repairs. If a qualified service technician is required, please contact the factory.

		Possible Cause								
		Manual Gas Valve Or Gas Supply Turned Off/ Disconnected	Unit Not Plugged In	Faulty Ignition Module Or Flame Sense Circuit	Power Switch(s) Off / Faulty Control Transformer	Thermostats Turned To "Off"	Low Gas Pressure	Thermostats Not Calibrated	Thermostat Or Gas Valve Failure	Faulty Lamp/Switch
P r o b l e m	Pilot(s) Will Not Light	X	X	X	X		X			X
	Pilot Ready Light Will Not Illuminate	X	X	X	X		X			X
	Power Switch Will Not Illuminate			X		X		X	X	X
	Griddle Will Not Heat Up			X		X			X	X
	Inconsistent Surface Temperatures						X	X	X	
	Griddle Stays Hot Or Overheats							X	X	

NOTICE

All parts and service for your MagiKitch'n griddle should be ordered and installed by a MagiKitch'n Authorized Service and Parts (ASAP) dealer. Failure to do so might result in the warranty being voided.

6. Accessories

6.1. Standard

All plain steel and chrome plated griddles are shipped with a set of 4" (10cm) adjustable legs. The appliance also comes equipped from the factory with a manual gas shutoff valve, and the specified gas regulator for the model and gas type purchased.

Each MKG Chrome surfaced griddle is equipped with a Chrome Kit which includes a cleaning brush, cleaning powder, spatula, scraper, and scraper blade replacements. See the table below for Re-Order Part Nos.

Chrome Griddle Accessories	
Magi Kleans'r	9825-1525101
Palmetto Brush	9825-1524901
Spatula, (Chrome Surface)	9825-1525001
Scraper, (W/ Blade and Cover)	9825-1528001
Replacement Blades	9825-1528002

Using MagiKitch'n chrome griddle accessories are important to maintaining the life of the griddle's chrome surface

6.2. Optional

To order accessories for your griddle, call your local MagiKitch'n dealer for prices and availability. The list of available accessories for your new appliance will give you the flexibility to customize your griddle to the best fit for your operational requirements.

This section will show you a variety of front and rear work shelves, cutting boards, equipment stands, and other accessories to provide you with an efficient working appliance.

6.2.1. Service Shelves, Front

Shelf Model	MKG24	MKG36	MKG48	MKG60	MKG72
8" (20.3cm) Service Shelf, W/O Towel Bar	5125-1511601-C	5125-1511602-C	5125-1511603-C	5125-1511610-C	5125-1511611-C
*10" (25.4cm) Service Shelf, W/O Towel Bar	5125-1511604-C	5125-1511605-C	5125-1511606-C	5125-1511612-C	5125-1511613-C
*12" (30.5cm) Service Shelf, W/O Towel Bar	5125-1511607-C	5125-1511608-C	5125-1511609-C	5125-1511614-C	5125-1511615-C
8" (20.3cm) Service Shelf, W/ Towel Bar	5125-1511701-C	5125-1511702-C	5125-1511703-C	5125-1511710-C	5125-1511711-C
*10" (25.4cm) Service Shelf, W/ Towel Bar	5125-1511704-C	5125-1511705-C	5125-1511706-C	5125-1511712-C	5125-1511713-C
*12" (30.5cm) Service Shelf, W/ Towel Bar	5125-1511707-C	5125-1511708-C	5125-1511709-C	5125-1511714-C	5125-1511715-C
Towel Bar Only	5125-1511801-C	5125-1511802-C	5125-1511803-C	5125-1511804-C	5125-1511805-C

*** 10" and 12" service shelves are also available with pan cutouts. Consult factory for sizes and availability.**

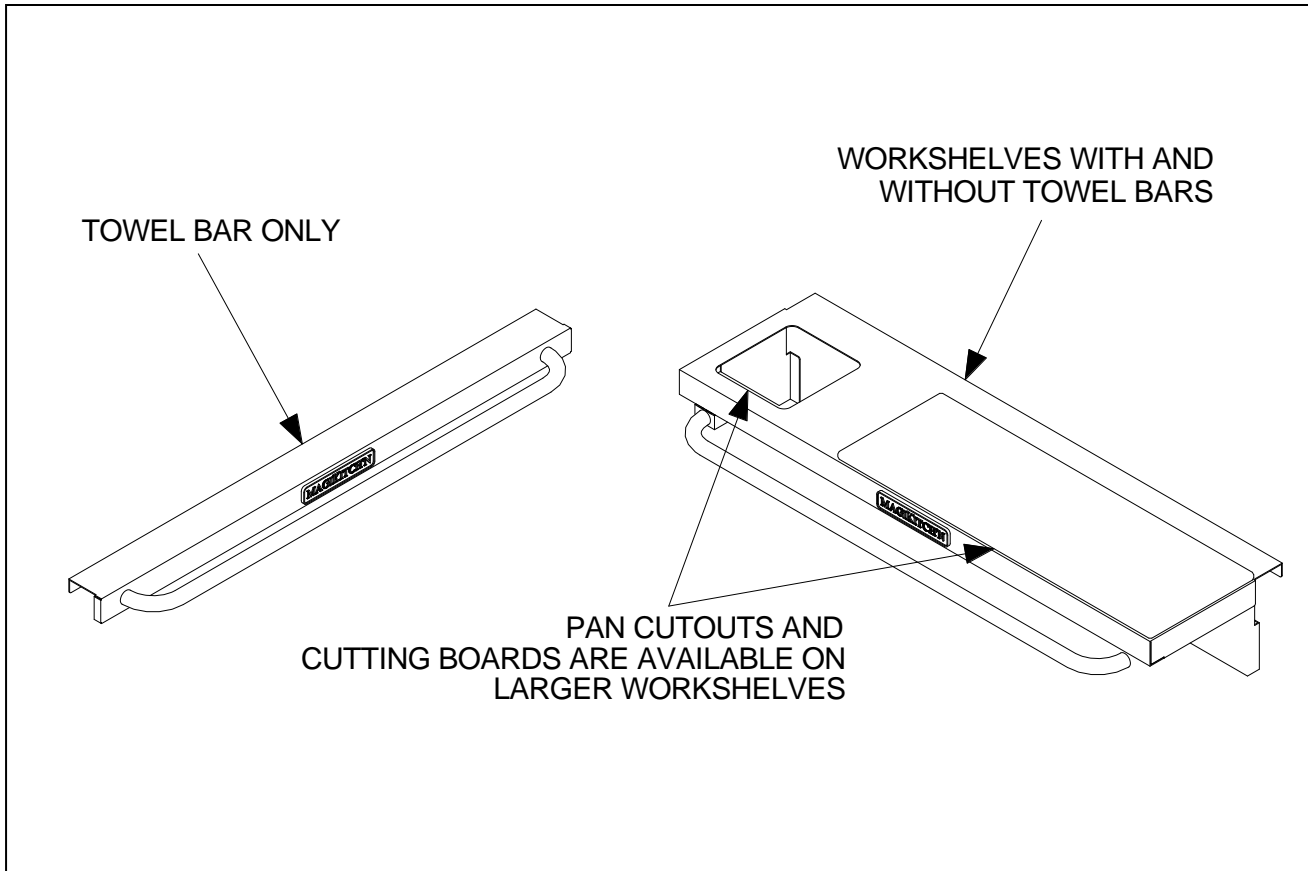

6.2.2. Cutting Boards

Size	Part No.
8" X 12" (20.3 cm X 30.5 cm) Cutting Board	1604-0643600-C
8" X 12" (20.3 cm X 61.0 cm) Cutting Board	1604-0643700-C
8" X 12" (20.3 cm X 122.0 cm) Cutting Board	1604-0643800-C
8" X 12" (20.3 cm X 183.0 cm) Cutting Board	1604-0643900-C

Other sizes are available, consult factory for size, price, and availability.

6.2.3. Warming Shelves, Rear

Shelf Model	Part No.
C/A, Shelf Rear MKG24	5225-1535701-C
C/A, Shelf Rear MKG36	5225-1535702-C
C/A, Shelf Rear MKG48	5225-1535703-C
C/A, Shelf Rear MKG60	5225-1535704-C
C/A, Shelf Rear MKG72	5225-1535705-C

Shelf Kits can be attached to existing models. The Stainless Steel shelf is removable from the shelf framework for easier cleaning if necessary.

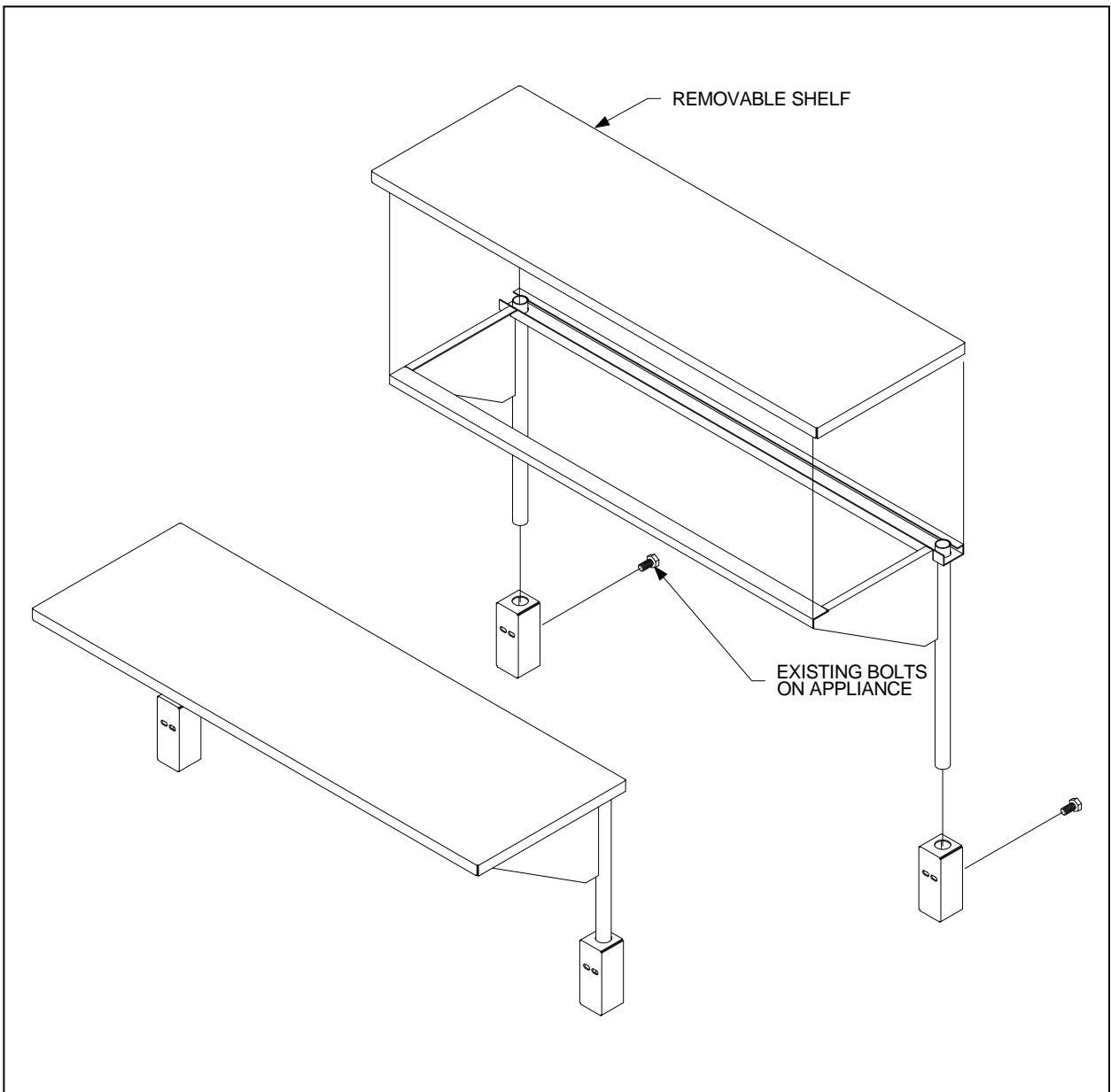

6.2.4. Equipment Stands

Equipment stands can be ordered with legs or casters (stands with casters shipped after May 2006 are equipped with adjustable casters).

NOTE:

It should also be noted that when ordering an equipment stand for your MKG appliance, you will also need to order a Joining Kit, Part No. 7225-1512101-C.

Equipment Stand Model	Part No.
MKG24, W/ Legs	5225-1512001-C
MKG24, W/ Casters	5225-1512002-C
MKG36, W/ Legs	5225-1512005-C
MKG36, W/ Casters	5225-1512006-C
MKG48, W/ Legs	5225-1512007-C
MKG48, W/ Casters	5225-1512008-C
MKG60, W/ Legs	5225-1512009-C
MKG60, W/ Casters	5225-1512010-C
MKG72, W/ Legs	5225-1512011-C
MKG72, W/ Casters	5225-1512012-C

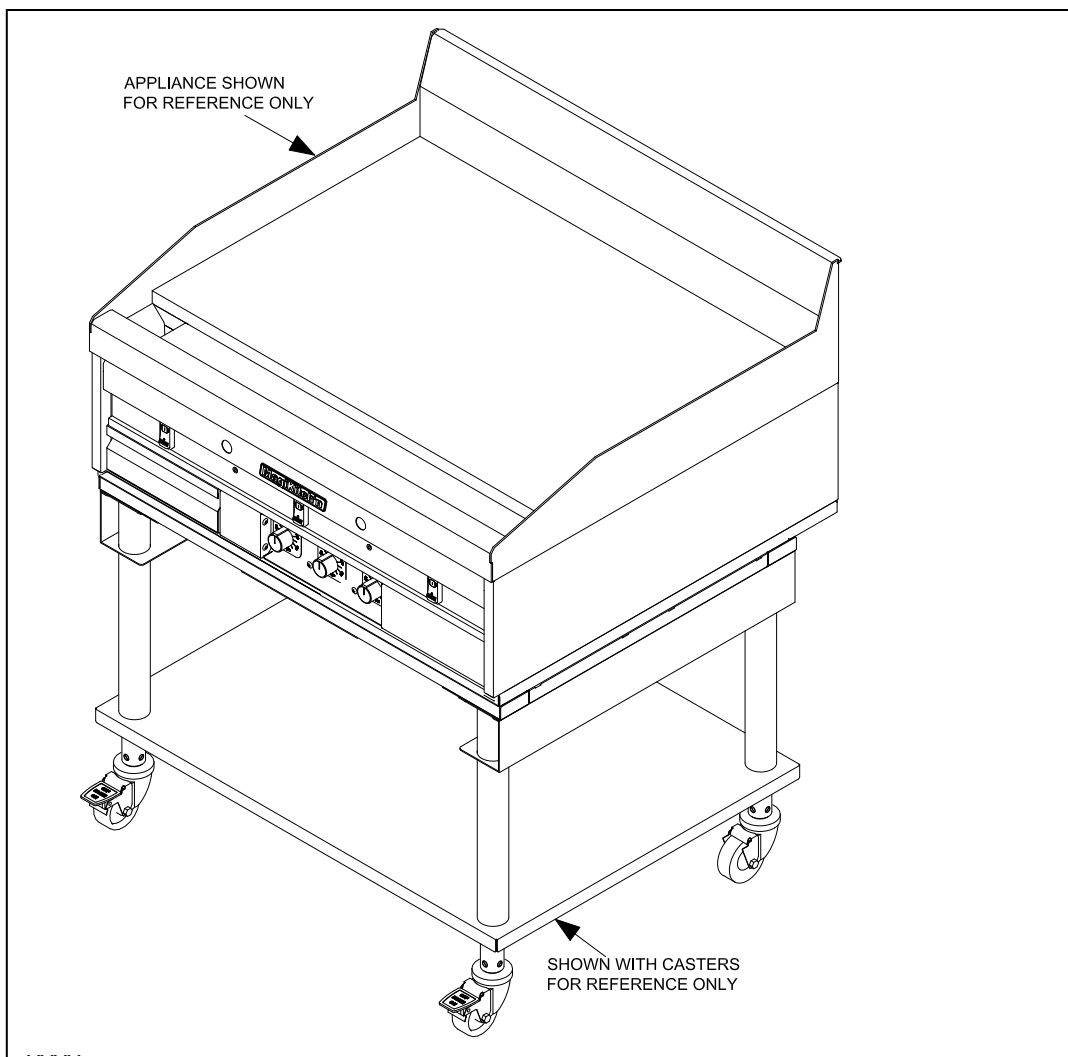

Equipment stands may be used to hold multiple MKG Griddles. They are also compatible with MagiKitch'n Series 600 APM Charbroilers.

6.2.5. Miscellaneous

Your appliance can also be used with the following miscellaneous accessories so you can customize your operation to your specific demands. The wall spacers listed below insure that you cannot push the appliance too close to the rear wall. The Utensil box gives you a handy location to store your cooking tools. The Utensil box does not interfere with any controls, and can be moved from one end of the griddle to the other without the use of tools.

Accessory	Part No.
6" (15.2 cm) Wall Spacer, MKG	5425-1526703-C
Utensil Box, MKG	9825-1532501-C
Utensil Box, MKG Towel Bar Only	9825-1532502-C

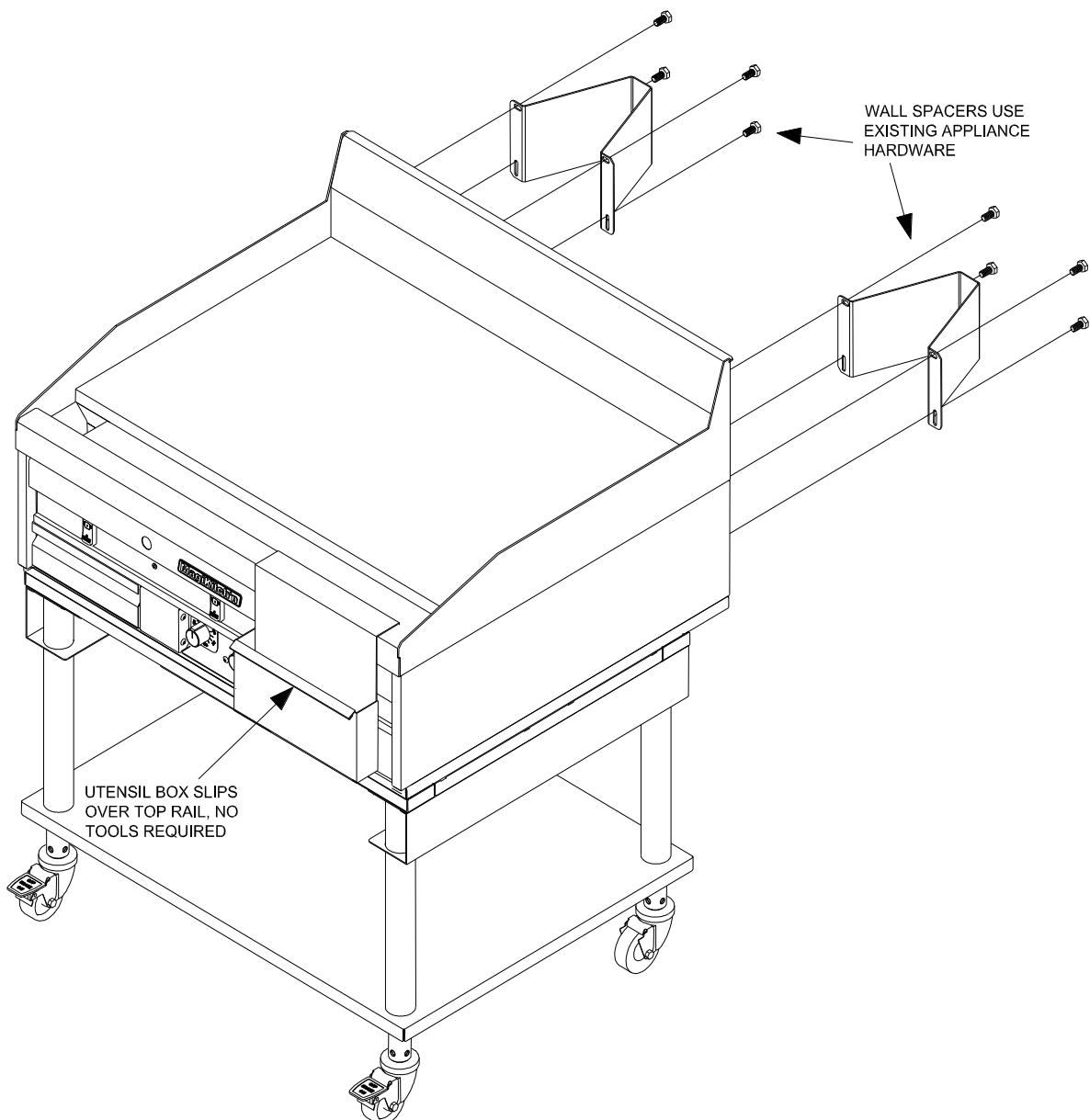



7. Notes

PAGE INTENTIONALLY LEFT BLANK



Original Instructions

In the event of problems with or questions about your order, please contact the MagiKitch'n factory at:

PH- (800) 264-7827 World Wide
Website- www.magikitchn.com

In the event of problems with or questions about your equipment, please contact the MagiKitch'n Authorized Service and Parts representative (ASAP) covering your area or contact Pitco at the numbers listed to the left.

Address - 265 Hobson St. Smithville, TN 37166