

INSTRUCTION MANUAL

MONTAGUE LEGEND

Gas Fired Deluxe Griddles

MODELS:

All "DG" Series Griddles

These instructions should be read thoroughly before attempting installation.
Set up and installation should be performed by qualified installation personnel.

Keep area around appliances free and clear from combustibles.

PLEASE RETAIN THIS MANUAL
FOR FUTURE REFERENCE.



THE MONTAGUE COMPANY

1830 STEARMAN AVENUE, P.O. BOX 4954

HAYWARD, CA 94540-4954

TEL: 510/785-8822 FAX: 510/785-3342

IMPORTANT

WARNING:

Improper installation, adjustment, alteration, service or maintenance can cause property damage, injury or death. Read the operating and maintenance instructions thoroughly before installing or servicing this equipment.

FOR YOUR SAFETY:

Do not store or use gasoline or other flammable vapors and liquids in the vicinity of this or any other appliance.

INSTRUCTIONS TO BE FOLLOWED IN THE EVENT THE USER SMELLS GAS MUST BE POSTED IN A PROMINENT LOCATION. THIS INFORMATION MAY BE OBTAINED BY CONSULTING THE LOCAL GAS SUPPLIER.

SHIPPING DAMAGE CLAIM PROCEDURE

For your protection, please note that equipment in this shipment was carefully inspected and packed by skilled personnel before leaving the factory. The transportation company assumed full responsibility for safe delivery upon acceptance of this shipment.

If shipment arrives damaged:

1. **VISIBLE LOSS OR DAMAGE** - Be certain this is noted on freight bill or express receipt, and signed by person making delivery.
2. **FILE CLAIM FOR DAMAGES IMMEDIATELY** - Regardless of the extent of damage.
3. **CONCEALED LOSS OR DAMAGE** - If damage is unnoticed until merchandise is unpacked, notify transportation company or carrier immediately, and file "concealed damage" claim with them. This should be done within fifteen (15) days of date that delivery was made to you. Be sure to retain container for inspection.

We cannot assume responsibility for damage incurred in transit. We will, however, be glad to furnish you with necessary documents to support your claim.

INSTALLATION

Montague gas griddles are manufactured for use with the type of gas indicated on the nameplate.

The Montague heavy duty gas griddles are produced with the best possible material and workmanship. PROPER INSTALLATION IS ESSENTIAL FOR SAFE AND EFFICIENT TROUBLE-FREE OPERATION.

THE INSTALLATION INSTRUCTIONS CONTAINED HEREIN ARE FOR THE USE OF QUALIFIED INSTALLATION AND SERVICE PERSONNEL ONLY. INSTALLATION OR SERVICE BY OTHER THAN QUALIFIED PERSONNEL MAY RESULT IN DAMAGE TO THE UNIT AND/OR INJURY TO THE OPERATOR.

Qualified installation personnel are individuals, a firm, corporation or company which either in person or through a representative are engaged in, and are responsible for:

The installation or replacement of gas piping or the connection, installation, repair or servicing of equipment, who is experienced in such work, familiar with all precautions required, and has complied with all requirements of state or local authorities having jurisdiction. Reference: National Fuel Gas Code Z223.1

READ CAREFULLY AND FOLLOW THESE INSTRUCTIONS

THE GRIDDLE(S) MUST BE INSTALLED IN ACCORDANCE WITH LOCAL CODES, OR IN THE ABSENCE OF LOCAL CODES, WITH THE NATIONAL FUEL GAS CODE, ANSI Z223.1, NATURAL GAS INSTALLATION CODE, CAN/CGA-B149.1, OR THE PROPANE INSTALLATION CODE, CAN/CGA-B149.2, AS APPLICABLE INCLUDING:

1. The appliance and its individual shutoff valve must be disconnected from the gas supply piping system during any pressure testing of that system at test pressures in excess of 1/2 psig. (3.45 kPa).
2. The appliance must be isolated from the gas supply piping system by closing its individual manual shutoff valve during any pressure testing of the gas supply piping system at test pressure equal to or less than 1/2 psig. (3.45 kPa).

PROVISIONS MUST BE MADE FOR ADEQUATE AIR SUPPLY TO THE UNIT(S).

WARNING - ELECTRICAL GROUNDING INSTRUCTIONS

This appliance is equipped with a three-prong (grounding) plug for your protection against shock hazard and should be plugged directly into a properly grounded three-prong receptacle. Do not cut or remove the grounding prong from this plug.

INSTALLATION

THIS APPLIANCE, WHEN INSTALLED, MUST BE ELECTRICALLY GROUNDED IN ACCORDANCE WITH LOCAL CODES, OR IN THE ABSENCE OF LOCAL CODES, WITH THE NATIONAL ELECTRICAL CODE, ANSI/NFPA No. 70 OR THE CANADIAN ELECTRICAL CODE, CSA C22.2.

VENTILATING HOOD

The griddle(s) must be installed under a properly designed ventilation hood. The hood should extend at least 6" beyond all sides of the unit. The hood should be connected to an adequate mechanical exhaust system.

Information on the construction and installation of ventilating hoods may be obtained from the "Standard for the Installation of Equipment for the Removal of Smoke and Grease Laden Vapors from Commercial Cooking Equipment", NFPA No. 96-1987, available from the National Fire Protection Association, Batterymarch Park, Quincy, MA 02269.

It is also necessary that sufficient room air ingress be allowed to compensate for the amount of air removed by the ventilation system. Otherwise, a subnormal atmospheric pressure will occur which may interfere with burner performance or may extinguish the pilot flame. In case of unsatisfactory unit performance, re-check performance with the exhaust fan in the "OFF" position.

CLEARANCES

Adequate clearance must be provided in aisle and at the side and back to allow for serviceability. Adequate clearance for air openings into the combustion chamber must be provided.

	CLEARANCES	
	COMBUSTIBLE CONSTRUCTION	NONCOMBUSTIBLE CONSTRUCTION
BACK	3"	0"
LEFT & RIGHT SIDE	2"	0"

WITH 24" LEGS: SUITABLE FOR INSTALLATION ON COMBUSTIBLE FLOORS. WITH 4" LEGS OR WITH CUSTOM BASE: FOR USE ONLY ON NONCOMBUSTIBLE COUNTERS.

CAUTION

DO NOT OBSTRUCT THE FLOW OF COMBUSTION AND VENTILATION AIR TO THE UNIT. KEEP THE APPLIANCE AREA FREE AND CLEAR FROM COMBUSTIBLES.

ASSEMBLY

Uncrate griddle as near to final location as possible. Remove all shipping straps, wrapping, cardboard, or upper crating. Leave the bottom wood pallet. Use a fork lift or an equipment hoist to raise the bottom pallet and the griddle off the floor. Loosen the two Allen screws in each leg socket. For counter models, install the supplied 4-inch legs into the leg socket and tighten the Allen screws. Place the griddle on the counter or equipment stand where it will be used. For models supplied with an equipment stand, raise the four legs and lower shelf assembly into the leg sockets and tighten the Allen screws. Lower the griddle and stand into place where it will be used. Remove and discard the wood pallet when completed.

WIRING DIAGRAM

The wiring diagram is located on the rear of the griddle. If it cannot be found please call your local Montague Servicer or Montague Dealer.

SETTING IN PLACE

Using an accurate carpenter's level, level the griddle front to back and side to side using the adjustable foot at the bottom of the legs. Turn the bottom of the foot counter-clockwise with a wrench to lengthen the leg. If casters are added to an equipment stand there is not adjustment to level the griddle. If floors are uneven, shim plates may be required for proper operation of the griddle.

ADJUSTING THE GRIDDLE PLATE

For proper operation of the griddle and adequate grease runoff, it is imperative that the griddle plate be pitched towards the front. An improperly pitched plate may result in unwanted grease build-up, excessive guard rail and control panel temperatures, pilot out-ages, and pre-mature failure of the griddle control components and burners.

Plate leveling bolts are located beneath the rear of the griddle plate. To access these bolts, remove the back and top screws that hold the flue extension in place and lift the extension off. Place an accurate carpenter's level in the center of the plate. Turn the leveling bolts equally counter-clockwise with a wrench until the rear of the plate is raised sufficiently to "crack" the bubble (see Figure below). This will result in approximately a 1/8-inch forward pitch of the plate. Replace and fasten the flue extension.

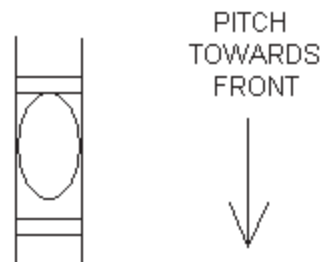

Figure 1.

Illustrating a "cracked" bubble on a carpenter's level.

INSTALLATION

GAS APPLIANCE REGULATOR

The gas regulator supplied with the griddle must be installed on the manifold inlet at the back of the unit and adjusted for the manifold pressure specified on the equipment nameplate. Unless otherwise specified, a manifold pressure of 6.0 inches of water column for natural gas and 10.0 inches of water column for propane gas is appropriate.

GAS CONNECTION

Before connecting the griddle to the gas supply line, be sure that all new piping has been cleaned and purged to prevent any foreign matter from being carried into the controls by the gas. In some cases, filters or drops are recommended. A separate Gas Shut-Off Valve must be installed upstream from the gas pressure regulator adjacent to the griddle and located in an accessible area.

WARNING: CAP ALL UNUSED OPEN ENDS OF THE GAS SUPPLY MANIFOLD.

It is important that adequately sized piping be run directly to the point of connection at the griddle with as few elbows and tees as possible. Consult local gas company for proper piping size and gas pressure.

PIPE JOINT COMPOUND OR THREAD SEALANT THAT IS USED SHOULD BE RESISTANT TO ACTION OF LIQUEFIED PETROLEUM GASES.

Turn Gas Shut Off Valve "ON" and immediately check carefully for gas leaks. Do this before attempting to operate the griddle.

TEST ALL PIPE JOINTS FOR LEAKS BEFORE OPERATING THIS INCLUDES ALL GAS CONNECTIONS THAT MAY HAVE LOOSENED DURING SHIPMENT. USE A RICH SOAP SOLUTION (OR OTHER ACCEPTED LEAK TESTER) AROUND ALL PIPE CONNECTIONS AND ALL OTHER JOINTS. DO NOT USE AN OPEN FLAME. ABSOLUTELY NO LEAKAGE SHOULD OCCUR, OTHERWISE THERE IS A DANGER OF FIRE OR EXPLOSION DEPENDING UPON CONDITIONS. NEVER USE IF LEAKAGE IS DETECTED.

PILOT ADJUSTMENT

Pilots on all griddles, except those models with suffix “-MFF”, are controlled by fixed orifices and are not adjustable. If the “-2,4OB” model option for open burners is included, then these pilots are adjustable. The front and rear pilots are controlled by one valve. To adjust the pilots, turn the adjusting screw counter-clockwise to increase or clockwise to decrease the pilot flame. Adjust the flame to a point where only a trace of yellow tip remains.

Models with suffix “-MFF”, both griddle and open burner pilots are controlled by fixed injectors and cannot be adjusted.

BURNER ADJUSTMENT

The efficiency of the griddle depends on a delicate balance between the supply of air and volume of gas so that complete combustion is achieved. Whenever this balance is disturbed, poor operating characteristics occur.

The air supply is controlled by an air shutter on the front of the burner. The air shutter openings should be increased until the flame on the burner begins to "lift." The air shutter should then be closed slightly and locked in place. A yellow streaming flame indicated insufficient air. This condition can be corrected by increasing the air shutter opening.

THERMOSTAT ADJUSTMENT

The griddle thermostats are calibrated at the factory and need no additional adjustment if the gas manifold pressure is correct. If transit or local conditions have affected the calibration, then refer to the service section of this manual for proper procedures for recalibration.

OPERATION

OPERATING INFORMATION FOR THE GRIDDLE HAS BEEN PREPARED FOR USE BY QUALIFIED AND/OR PROFESSIONAL OPERATING PERSONNEL.

CAUTION

DO NOT OBSTRUCT THE FLOW OF COMBUSTION AND VENTILATION AIR TO THE GRIDDLE. KEEP THE APPLIANCE AREA FREE AND CLEAR FROM COMBUSTIBLES.

GAS CONTROLS

IN THE EVENT A GAS ODOR IS DETECTED, SHUT DOWN UNITS AT MAIN SHUT OFF VALVE AND CONTACT THE LOCAL GAS COMPANY OR GAS SUPPLIER FOR SERVICE.

MODELS WITH SUFFIX “-M & -T”

These models contain standing automatic pilots without pilot safety valves. To light the griddle pilots, first make certain all burner manual valves or thermostat dials are rotated full clockwise to the “OFF” position. Open the gas supply shut-off valve. Immediately push the piezo igniter button repeatedly until the pilot flame is visible through the pilot viewing slot in the upper control panel. Repeat procedure for all pilots. If these models contain the “-(2,4)OB” open burner option, follow the same procedure above, then light each pilot with a match or taper by accessing through the top grate openings.

To operate the griddle or open burners with manual valves (**model suffix “-M”**), first check that the pilot(s) are burning. Then rotate the burner valve handle counter-clockwise to full “ON” to ignite the burner. Adjust the flame height to obtain the desired heat. To shut down, rotate the valve handle clockwise to the “OFF” position.

To operate the griddle on models with modulating thermostat controls (**model suffix “-T”**), first check that the pilot(s) are burning. Then push the thermostat dial inward and rotate dial counter-clockwise fully to ignite the burner. After ignition, turn the thermostat dial to the desired setting. To shut down, rotate the thermostat dial clockwise to the “OFF” position.

MODELS WITH SUFFIX “-SAT, SST, MST, & -TSF”

These models contain standing automatic pilots with 100% pilot safety valves that automatically shut off the gas supply if the griddle pilot goes out. To light the griddle pilots, first make certain all burner manual valves or thermostat dials are rotated fully clockwise to the “OFF” position. If the model contains a main power switch it should be turned off. Loosen the two screws in the lower control panel sufficiently to remove the upper control panel by lifting up and then outward. Open the gas supply shut-off valve. Locate the red button on the pilot safety valve and hold the button in. Repeatedly push the appropriate piezo igniter button until the pilot is visible through the pilot-viewing slot. Continue to hold the button down for approximately 30 seconds or until the pilot remains burning after the button is released. If the pilot goes out, repeat process. Continue procedure until all pilots are burning. Replace the upper control panel and tighten the screws in the lower panel. This procedure does not need to be repeated unless the pilot flame is extinguished.

On models containing the “-(2,4)OB” open burner option, these pilots are lit from above by accessing through the grate openings. First make certain the burner valves are rotated full clockwise to the “OFF” position. Open the gas shut-off valve. Light the pilots for each burner with a match or taper.

To operate the griddle/open burners with manual valves (**model suffix “-MST”**), first check that the pilot(s) are burning. Then rotate the burner valve handle counter-clockwise to full “ON” to ignite the burner. Adjust the flame height to obtain the desired heat. To shut down, rotate the valve handle clockwise to the “OFF” position.

To operate the griddle on models with modulating thermostat controls (**model suffix “-TSF”**), first check that the pilot(s) are burning. Then push the thermostat dial inward and rotate dial counter-clockwise fully to ignite the burner. After ignition, turn the thermostat dial to the desired setting. To shut down, rotate the thermostat dial clockwise to the “OFF” position.

To operate a griddle with snap-action thermostats (**model suffix “-SAT”**), first check that the pilots are burning and the main power switch is “ON” (red indicator light is on). Turn the desired burner thermostat dial(s) clockwise to the set temperature. The amber burner indicator light next to the dial will come on and remain on until the selected temperature is reached and the burner turns off. During operation the burner indicator light will cycle on and off with the burner as the thermostat maintains the set temperature. To turn off the burner, rotate the thermostat dial counter-clockwise to “OFF”. To turn off the griddle, turn the main power switch to “OFF”.

To operate a griddle with solid-state thermostats (**model suffix “-SST”**), first check that the pilots are burning and the main power switch is “ON”. Turn on the burner thermostat switch (press the “I” marking) next to the thermostat dial. The amber burner indicator light will come on with the burner. Set the dial to the desired set temperature. The burner indicator light will go out when the set temperature is reached, and will cycle on and off during operation as the thermostat maintains the set temperature. To turn off the burner, rotate the thermostat dial clockwise until it stops, AND TURN OFF THE BURNER THERMOSTAT SWITCH (press the “O” marking). To turn off the griddle, turn the main power switch to “OFF”.

OPERATION

SUFFIX “-(PR)” PILOT RE-LIGHT OPTION

On griddles with the “-(PR)” Pilot Re-light Option, an electronic spark module automatically lights the pilot. To light the griddle pilots, follow the procedure above up until the point where you would push the piezo igniter button. Instead, simply turn the main power switch on (the “I” position with the red indicator light on). The spark module will continuously spark until the pilot is burning. Continue with the procedure above until all pilots are burning. The spark module will continue to spark until the all pilots are burning, which may be distracting but does not harm the griddle in any way. If any pilot is extinguished for any reason, the spark module will automatically re-light it without loss of service of the griddle as long as the main power switch is on. If the main power is turned off the pilots will continue to burn, but if extinguished they will not re-light automatically, but instead the safety will shut off the gas supply after 30 to 45 seconds.

Operation of the griddle with or without this option is the same.

SUFFIX “-(EI)” ELECTRONIC IGNITION OPTION

On griddles with the “-(EI)” Electronic Ignition Option, an electronic spark lights each pilot, and then supplies gas to whichever burner is being called on by the thermostat. To light the griddle pilots, make certain the griddle thermostats are rotated full clockwise to the “OFF” position and the main power switch is turned off. Open the gas supply shut-off valve and turn the main power switch on (the “I” position with the red indicator light). The electronic ignition module will spark continuously until all pilots are burning, and will maintain them on until the main power switch is turned off (the “O” position) at the completion of the use of the griddle. If the pilot fails to ignite within 50 seconds, a complete shut down (lock-out) of the ignition system will occur. To initiate re-ignition turn the main power switch “OFF”, wait at least 30 seconds, and then turn the main power switch back “ON”. If three successive shut downs occur, check the entire system for possible causes.

Operation of a griddle with or without this option is the same.

MODELS WITH SUFFIX “-MFF”

These models are equipped with manual flame-failure valves. Each valve has an independent supply line to the pilot and the burner, and contains a thermocouple that senses when the pilot is burning. This valve will not supply gas to the burner unless the pilot is burning and will cut-off supply if the pilot is extinguished during operation.

To operate griddles with suffix “-MFF”, first make certain the main gas shut-off valve is turned on. Push in the burner valve and turn it counter-clockwise to the ignition/pilot position (“spark” symbol). Hold the valve fully in while repeatedly pushing the piezo igniter button until the pilot is burning. Continue holding the valve in for approximately 20 second or until the flame stays on when released. If the pilot goes out, wait five (5) minutes and repeat the procedure.

With the pilot burning, push the valve in and turn counter-clockwise fully (to the “flame” symbol) to ignite the burner, then adjust it back clockwise to obtain your desired grilling temperature. If the griddle will be out of service for a short period, turn the valve clockwise back to the ignition/pilot position and the burner will be off, but the pilot will remain burning. To shut the burner off, turn the valve handle fully clockwise to off (the “circle” symbol).

On models containing the “-(2,4)OB open burner option, follow the procedures above, except light the burner pilot with a match or taper by accessing through the openings in the top grate. Adjust the heat of the open burner by adjusting the height of the flame as described above. To shut the burner off, turn the valve handle fully clockwise to the off position.

CARE AND CLEANING

CAUTION: TURN OFF GAS SUPPLY WHEN SERVICING GAS CONTROL SYSTEM. ALWAYS DISCONNECT POWER FROM GRIDDLE BEFORE REMOVING EITHER CONTROL PANEL FOR SERVICE OR CLEANING.

The complete griddle should be given a periodic general cleaning. Lint and grease suspended in the air tend to collect in passages. Therefore, all flueways, air passages and openings, burner ports, primary air openings, etc. should be periodically cleaned to prevent clogging.

Griddle tops are designed to have food cooked directly on the surface. Do not put pots or pans on the griddle surface. This will scratch or nick the surface and result in improper cooking or sticking of product. Never salt food over a griddle since this will build up a gummy residue making it difficult to clean.

Avoid hitting the surface of the griddle with the edge of a spatula since this will cause nicks. The most frequently used temperatures are 300°F to 350°F. After one firing, the griddle plate will discolor. This is normal and will not affect cooking performance.

Check the grease container and drain frequently during heavy use to prevent overflow.

The open burners are designed for flexibility and the preparation of numerous types of products. An operation that cooks to order or uses the equipment for back-up may find open type burners most suited to their needs.

NOTE: Many parts of the equipment are raw steel, i.e., griddle top, top grate, solid hot tops etc. and can react with moisture forming rust. This is normal and not considered a defect. Clean with a stainless steel or fiber pad. A light coating of salt free oil may be applied to prevent further rusting.

EXTERIOR

PAINTED SURFACE: Allow equipment to cool after use and wash with a mild detergent or soap solution. Dry thoroughly with a dry cloth.

STAINLESS STEEL SURFACE: To remove dirt, grease, or product residue, from stainless steel use ordinary soap and water (with or without detergent) applied with a sponge or cloth. Dry thoroughly with a clean cloth.

To remove grease and food splatter, or condensed vapors, that have baked on the equipment apply cleanser to a damp cloth or sponge and rub cleanser on the metal in the direction of the polishing lines on the metal. Rubbing cleanser as gently as possible in the direction of the polished lines will not mar the finish of the stainless steel. **NEVER RUB WITH A CIRCULAR MOTION.** Soil and burnt deposits which do not respond to the above procedure can usually be removed by rubbing the surface with SCOTH-BRITE scouring pads or STAINLESS scouring pads. **DO NOT USE ORDINARY STEEL WOOL** as any particles left on the surface will rust and further spoil the appearance of the finish. **NEVER USE A WIRE BURSH, STEEL SCOURING PADS (EXCEPT STAINLESS), SCAPER, FILE OR OTHER STEEL TOOLS.** Surfaces which are marred collect dirt more rapidly and become more difficult to clean. Marring also increases the possibility of corrosive attack.

MAINTENANCE

To remove heat tint: Darkened areas sometimes appear on stainless steel surfaces where the area has been subjected to excessive heat. These darkened areas are caused by thickening of the protective surface of the stainless steel and are not harmful. Heat tint can normally be removed by the foregoing, but tint which does not respond to this procedure calls for a vigorous scouring in the direction of the polish lines, using SCOTCH-BRITE scouring pads or a STAINLESS scouring pad in combination with a powdered cleanser. Heat tint action may be lessened by not applying or by reducing heat to equipment during periods.

MAINTENANCE GRIDDLE SEASONING

1. Remove all factory applied protective material by washing with hot water, mild detergent or soap solution.
2. Apply a thin coat of hydrogenated shortening to the griddle surface, about one ounce per square foot of griddle surface. Spread over the entire griddle surface with a cloth to create a thin film. Wipe off any excess with a cloth.
3. Heat the griddle slowly for 15 to 20 minutes, then wipe away shortening. Repeat the procedure 2 to 3 times until the griddle has a slick, mirror like finish. Do this until you have reached the desired cooking temperature.

IMPORTANT: Do not attain a high griddle temperature (450°F/232°C) during the "break-in" period.

NOTE: Steel griddle surface will tone (blue discoloration) from heat. This toning will not diminish function or operation and is not a defect.

CLEANING SCHEDULE

OPEN TOP SECTION

DAILY: After grates and burner bowls are cooled, soak in solution of sal soda or other grease solvent. Thoroughly wash open top section with a damp cloth using a mild detergent soap. Rinse with clean, damp cloth and dry thoroughly. Remove and clean drip pan(s) under burners.

WEEKLY: Brush burner head with a stiff wire brush and clean clogged ports with a stiff wire or ice pick.

GRIDDLE SECTION

DAILY: Use flat edge of spatula or metal scraper to keep surface free of encrusted material during use, wipe frequently with heavy absorbent cloth. After griddle is cooled, polish with soft griddle stone or a good grade grill pad. **DO NOT SCRATCH.** The griddle may be washed with warm water and a cleanser. Water will not crack this griddle plate.

Empty grease container as often as necessary.

To oil the griddle, use a hydrogenated shortening. Never use salad oils, margarine or butter, as these shortenings cannot withstand temperatures greater than 300 degrees fahrenheit.

WHEN SERVICE IS NEEDED, CONTACT A LOCAL SERVICE COMPANY, DEALER, OR FACTORY TO PERFORM MECHANICAL MAINTENANCE REPAIRS. THESE INSTRUCTIONS ARE INTENDED FOR USE BY COMPETENT SERVICE PERSONNEL.

CAUTION: TURN OFF GAS SUPPLY WHEN SERVICING GAS CONTROL SYSTEM. ALWAYS DISCONNECT POWER FROM GRIDDLE BEFORE REMOVING EITHER CONTROL PANEL FOR SERVICE.

COMPONENT ACCESS

Removal of several equipment panels will provide easy access for performing adjustments and service to the Montague Deluxe Griddle. Always make certain that the gas supply shut-off valve is closed and the power cord or electrical connection is disconnected before removing access panels.

UPPER CONTROL PANEL: To remove this panel, loosen the two screws that hold the lower control panel in place, and lift the upper panel up and outward. Place the panel in a location where it will not be damaged. Removing this panel is convenient when lighting the pilots or diagnosing a malfunctioning component.

LOWER CONTROL PANEL: To open the lower control panel, remove the two screws on either side and allow the panel to drop down against its hinges. It is normally not necessary to completely remove this panel.

This will allow access to the thermostats, switches, indicator lights, and piezo igniters located in the panel; and the pressure tap, safety valves, thermocouples, manual valves, solenoid valves, pilot re-light module, electronic ignition module, and solid-state thermostat controllers located in the control compartment.

UPPER HEAT SHIELD: At the top of the control compartment bulkhead is a removable heat shield covered with a white insulation mat. Remove the two screws on either side of this panel and remove it by rotating the top outward and placing it in a location where it will not be damaged.

This will allow access to the burner pilots, thermocouples, spark electrodes, main burners, and griddle plate temperature sensors.

CONTROL PANEL COMPONENTS

The switches, indicator lights, and piezo igniter can be replaced by disconnecting electrically and then removing the component out the front of the panel. Replacement components are either snapped into place or are held by a locking nut. Re-connect the components electrically making certain they are adequately protected from grounding.

SERVICE

MODULATING THERMOSTAT (MODEL SUFFIX “-T & -TSF”)

The Model BJ Robertshaw is a combination thermostat and gas valve. The gas is turned on and the temperature setting made by a single rotation of the dial. This valve automatically locks itself in the OFF position. To use, push dial inward, rotate counter-clockwise to the desired temperature. To shut gas off, rotate clockwise to OFF position.

This thermostat is a precision instrument carefully made and properly calibrated (i.e. the dial is properly set) at the factory to control temperatures accurately. It should control temperatures for the proper cooking of food without recalibration. The calibration of this thermostat should not be changed until considerable experience with cooking results has definitely proved that the thermostat is not maintaining the proper temperature.

<p>CAUTION: THE RECALIBRATION SHOULD NOT BE MADE UNTIL THE BYPASS (MINIMUM BURNER) FLAME HAS BEEN PROPERLY ADJUSTED.</p>
--

THERMOSTAT INSTALLATION

With the upper heat shield and both control panels removed, slide the thermostat bulb assembly into the support brackets and the slot in the underside of the plate. Tighten the two holding screws. The excess capillary tube should be pulled forward and down as low as possible out of the heat zone, so that there is no chance of it coming in contact with the burner flame. Push the sleeving up against the bulb holder. A loose fit between the bulb holder and plate may damage the thermostat so that it will not control the temperature of the griddle plate.

Mount the thermostat body to the manifold mounting flange with the two slotted hex screws located in the body. Make certain the o-ring gasket is in position and undamaged. Replace the heat shield and both control panels. Insert the dial on the thermostat stem.

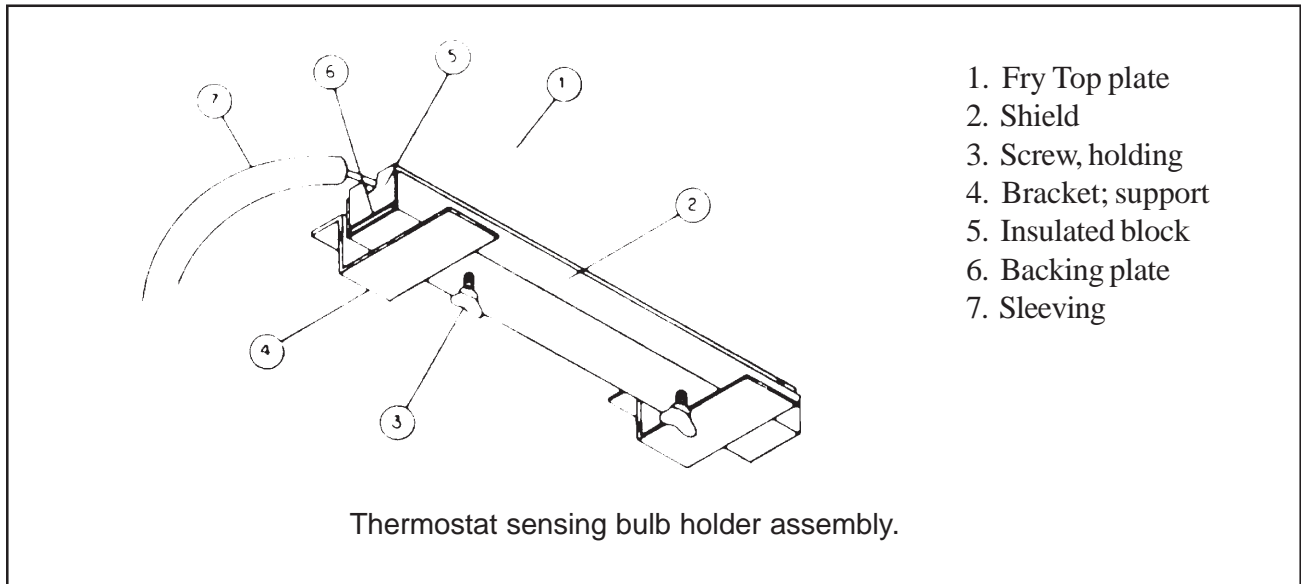

ADJUSTMENT OF BYPASS (MINIMUM BURNER) FLAME

This is the flame which must be maintained on the burners when the griddle has reached the temperature set on the dial. Enough gas must be bypassed by the control to keep the entire burner lit. The thermostat regulates the flame from high to low in accordance with the griddle temperature and will automatically turn down to this bypass flame when the temperature set on the dial is attained.

Special care should be taken to see that the thermostat bulb is in its proper place and no part of the capillary tube is in any flame or heat zone. The griddle plate should never be removed without first removing the thermostat bulb(s) from beneath the plate. Never allow capillary tube to be kinked or crushed.

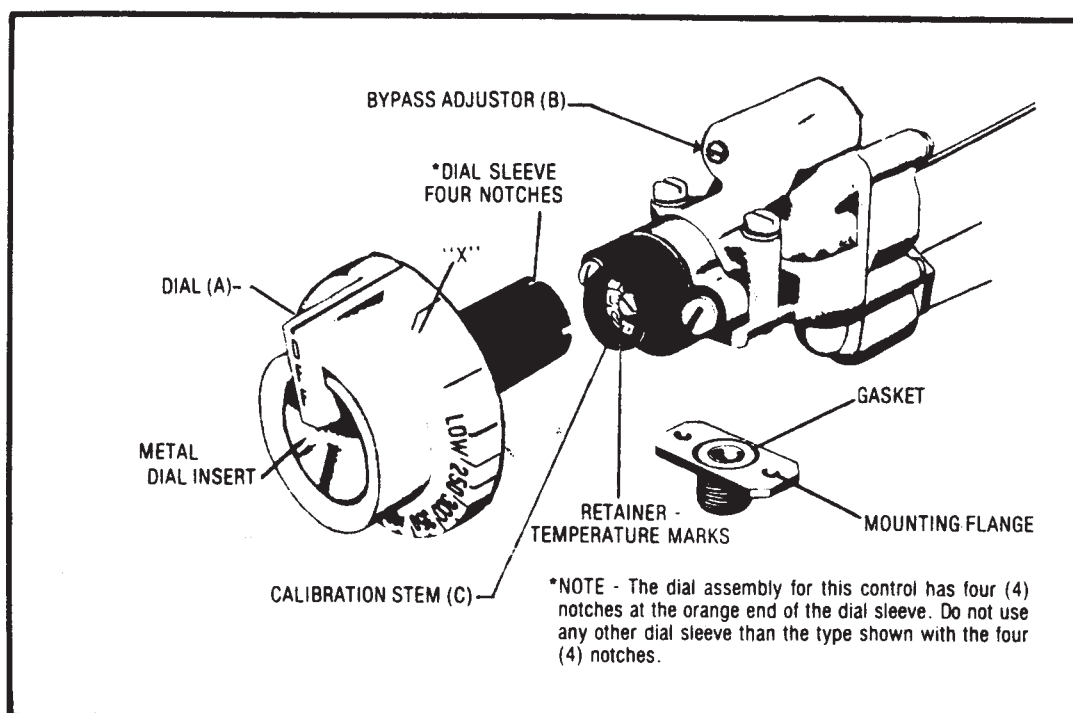

SERVICE

THE BYPASS MUST BE SET CAREFULLY AND ACCURATELY AS FOLLOWS:

1. Light burners and turn Dial (A) counter-clockwise and to a point midway between the "Gas On" mark and the next graduation to the right of it (shown by "X"). If the burner goes out entirely, the bypass is closed.
2. Slip off Dial (A). Remove the valve panel from the front of the range.
3. With a screwdriver turn bypass adjustor (B). Turning it out counterclockwise increases the bypass flame; turning it in clockwise decreases the bypass flame. Adjust until there is a flame approximately 1/8" high over the entire burner.
4. Replace dial, rotating dial clockwise until it snaps into its original position.
5. Reinstall the control panel.

GRIDDLE THERMOSTAT CALIBRATION CHECK:

The griddle temperature should be checked or recalibrated with griddle hot. NOTE: See "Adjustment of Bypass (Minimum burner) Flame" before recalibrating this thermostat.

HOT CHECK METHOD:

1. Place reliable thermometer in center of the top of the griddle plate over the thermal bulb.
2. Set Dial (A) to 350°F
3. Wait until temperature rises and remains constant.
4. If dial does not agree with thermometer readings, slip off Dial (A) and push out metal insert.
5. Replace dial, turn to 350°F mark.
6. Hold dial firmly, insert screwdriver through center of dial and push calibration stem (C) inward. DO NOT TURN THIS STEM.
7. While holding calibration stem (C) in, firmly with screwdriver, turn dial until it is set at the actual griddle temperature as shown by the thermometer. Release pressure on calibration stem. Replace dial insert.

SNAP-ACTION THERMOSTAT (MODEL SUFFIX “-SAT”)

The Robertshaw KX is a 120V snap-acting single pole thermostat. Its rugged compact design, silver contacts and heavy duty terminals are responsible for its dependable performance record.

CALIBRATION CHECK:

1. Place a reliable thermometer in the center of the top of the griddle plate over the thermal bulb.
2. Set the dial to 350°F.
3. The amber burner indicating light will switch from "ON" to "OFF" when the thermostat turns off the burner.
4. Allow three (3) such cycles for the temperature to stabilize.
5. Read the pyrometer or thermometer immediately after the light goes out for the third time and again immediately after the light comes on the next time.
6. If the average readings and the dial setting vary by more than 15°F, recalibrate by following the instructions outlined below.

To Recalibrate

1. Remove dial from dial shaft "B".
2. Turn screw "A" clockwise to decrease and counterclockwise to increase the temperature.
3. 1/4 turn changes the temperature 35°F.
4. Replace dial on dial shaft.
5. After a calibration is made, set the dial at 350°F and recheck the oven temperature using the method above, outlined by items 1 thru 6.

SERVICE

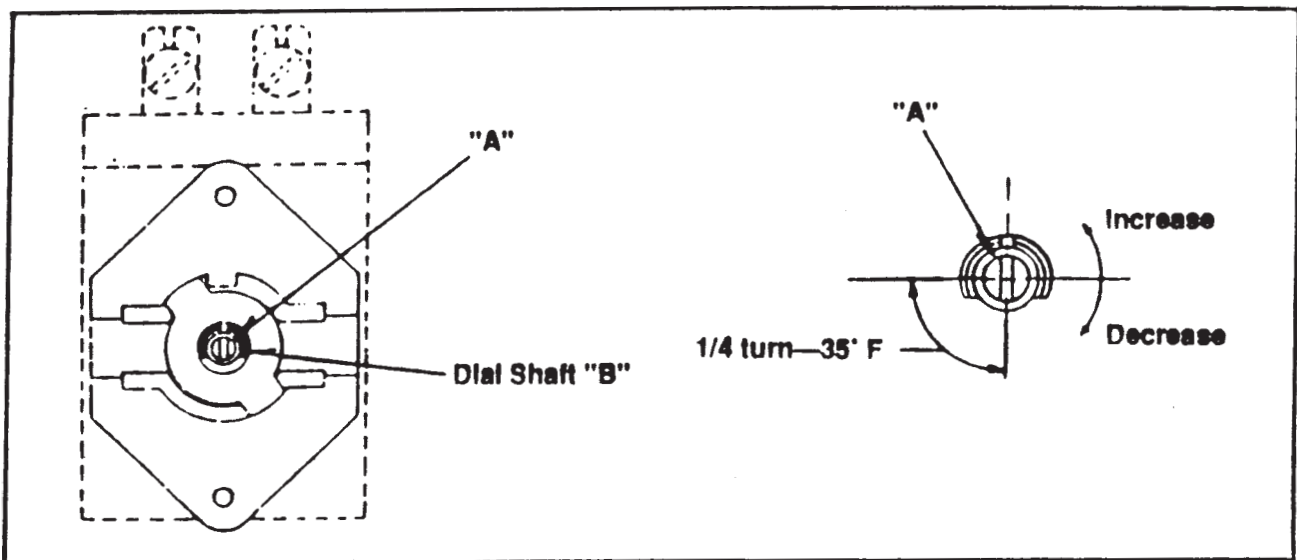

THERMOSTAT INSTALLATION

With the upper head shield and both control panels removed, slide the thermostat bulb assembly into the support brackets and the slot in the underside of the plate. Tighten the two holding screws. The excess capillary tube should be pulled forward and down as low as possible out of the heat zone, so that there is no chance of it coming in contact with the burner flame. Push the sleeving up against the bulb holder. A loose fit between the bulb holder and plate may damage the thermostat so that it will not control the temperature of the griddle plate.

Fasten the two slotted screws that hold the thermostat body onto the lower control panel. Make the electrical connections at the terminals making certain they are tight and properly protected from grounding. Install the heat shield, control panels, and the thermostat dial.

SOLID-STATE THERMOSTAT (MODEL SUFFIX “-SST”)

The 950FT Series solid-state temperature controller features a faster reacting 100K NTC thermistor sensor and a narrow on-off differential to achieve closer control with minimal overshoot. The remote panel mount potentiometer allows for easy component placement and a cooler location for the controller module.

THERMOSTAT INSTALLATION

With the upper heat shield and both control panels removed, slide the thermostat sensor assembly into the support brackets and the slot in the underside of the plate. Position the protective sleeving over the sensor bulb so the electrical leads are fully protected and covered until they exit the burner compartment. Tighten the two holding screws. Connect the sensor leads at the controller.

Remove the cover protecting the control modules from dirt and grease. Remove the two screws holding the controller mounting bracket and remove the bracket and the controllers sufficiently to access the individual controller module to be changed. Remove the four (4) nylon stand-offs from the mounting bracket. Remove the electrical connections at the power terminals, relay terminals, sensor terminals and potentiometer terminals and connect them to the appropriate terminals on the replacement module. Install the nylon stand-offs of the new module into the mounting bracket and fasten the bracket into position. Make sure all wires are neatly bundled to prevent grounding and replace the protective cover.

To replace just the remote potentiometer, the protective cover should be removed to access the three potentiometer connections (violet, yellow & orange). Remove the temperature dial and the lock nut fastening the potentiometer to the panel.

Install the new potentiometer and re-bundle the lead wires to prevent grounding.

Neither of these components are field serviceable if defective, and replacement is the only service option. Make certain when completed that the wire bundle feeding the control panel components does not become pinched when the control panel is closed and secured.

CALIBRATION CHECK

The solid-state thermostat is factory calibrated and does not require re-calibration as long as the control is working properly. The controller does have an OFFSET ADJUSTMENT that can be used to align the temperature dial markings with the indicator mark. First, carefully check calibration as follows;

1. Place a reliable thermometer in the center of the top of the griddle plate over the thermal bulb.
2. Set the dial to 350°F.
3. The amber burner indicating light will switch from "ON" to "OFF" when the thermostat turns off the burner.
4. Allow three (3) such cycles for the temperature to stabilize.
5. Read the pyrometer or thermometer immediately after the light goes out for the third time and again immediately after the light comes on the next time.
6. If the average readings and the dial setting vary by more than 10°F, adjust by following the instructions outlined below.

SERVICE

OFFSET ADJUSTMENT

DO NOT USE EXCESSIVE FORCE WHEN ADJUSTING TRIM POTS, DUE TO SINGLE TURN TRIM POT ROTATION.

NOTE: Units are shipped factory calibrated. Adjustment should only be made if optimum setting accuracy is desired at only one particular set point. This type of adjustment will reduce calibration accuracy at all other set points in the range.

To adjust setting, turn thumb head on trim pot slightly clockwise to increase process temperature and counterclockwise to decrease process temperature. This adjustment may be done using a 3/16" flatblade screwdriver. See Diagram.

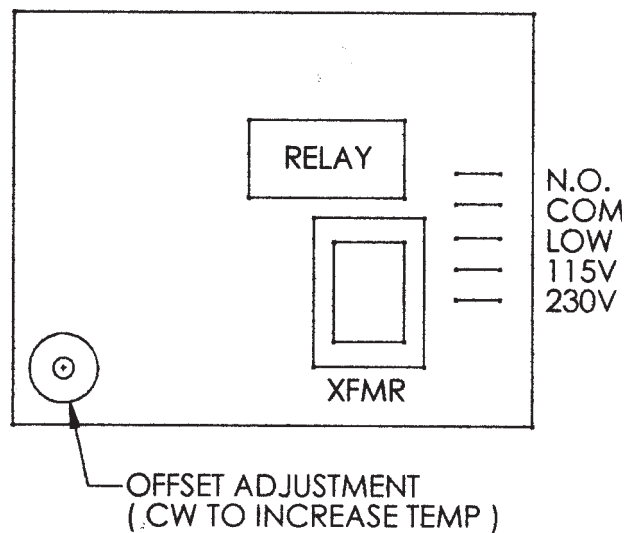

SAFETY PILOT VALVE

Model TS-11J is an automatic 100% safety pilot which provides complete gas shut off in event of pilot failure. The safety valve is held closed by spring pressure. When red bottom is pushed by hand, gas flows to pilot. Pilot heats thermocouple creating a very small amount of electricity. This energizes a magnetic coil under red button and holds valve open, permitting gas to flow to main burner and pilot without holding pressure on red button. In the event of pilot failure, the flow of electricity will stop and spring will stop flow of gas to both pilot and oven burner.

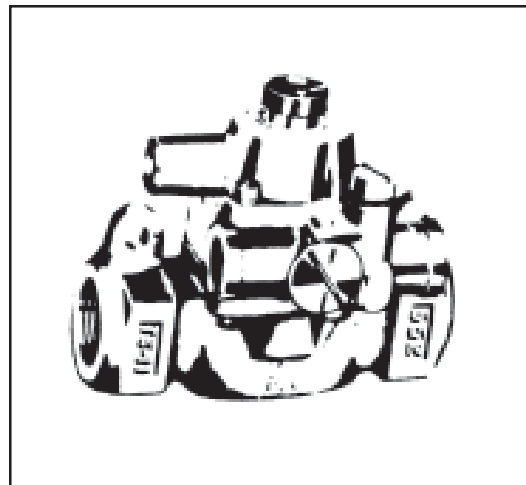

SERVICE

PILOT BURNER

PILOT SERVICE IN THE EVENT OF PILOT FLAME FAILURE

1. If pilot flame burns yellow, clean pilot orifice and pilot burner to insure a steady blue flame. The orifice can be cleaned by washing in a solvent and/or blowing out with air.
2. Flame must surround the thermocouple tip for approximately 1/2 inch.

THERMOCOUPLE OUTPUT	
CLOSED CIRCUIT MV RANGE	
NORMAL	NOT LESS THAN
15-25	8

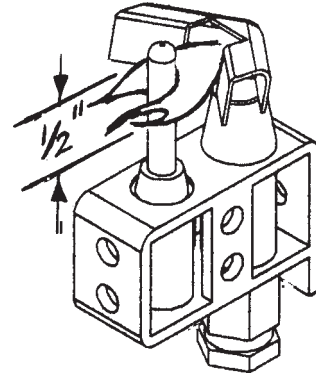

If the closed circuit check shows thermocouple output is greater than 8 millivolts and pilot will not remain lit when reset button is released, replace safety pilot magnet assembly.

3. Thermocouple lead connections must be tight, clean, and free of grease. The thermocouple nut should be started and turned all the way by hand. An additional quarter turn with a small wrench will then be sufficient.

CAUTION: OVERTIGHTENING MAY CAUSE DAMAGE TO THE THERMOCOUPLE OR MAGNET AND IS UNNECESSARY SINCE THIS IS AN ELECTRIC CONNECTION.

BURNER REPLACEMENT

Remove the upper heat shield and control panels. Disconnect the gas line from the solenoid valve to the orifice/elbow assembly. Loosen the orifice/elbow bracket screws sufficiently so the orifice hood will come free of the burner air shutter. Remove the burner out the front of the heat shield opening. To replace the burner, reverse the procedure. Make certain the rear burner bracket rests on the rear burner mount, with the locating pin centered in the bracket slot, and is held in place by the rear mount upper tabs.

PILOT RE-LIGHT OPTION (PR)

The pilot re-light module senses the pilot flame and will continuously spark until it is lit if it is extinguished. The re-light spark module is not serviceable, and only needs to be checked to be certain it has 120V power to it, the case is grounded through the mounting screws and the electrical connections are tight. The lead to the spark electrode should not be broken or grounded. The electrode should be positioned to result in a 0.150" gap to the pilot hood. If operation cannot be restored, the module should be replaced.

ELECTRONIC IGNITION OPTION (EI)

The electronic ignition control must verify that the pilot is burning before it will provide power to the main burner valve. If the pilot is extinguished during service, it will spark continuously for 50 seconds until lit, or the control will go into lock-out. To restart, the main power switch must be momentarily turned off/on. The pilot ignition control is not serviceable. Check to be certain it has 24V power to it and the case is well grounded through the mounting screws. Check all electrical connections and the spark and sensor leads for breaks or grounding. The spark electrode gap is set at 0.100" by the pilot bracket geometry and is not adjustable. If operation cannot be restored, the pilot ignition control should be replaced.

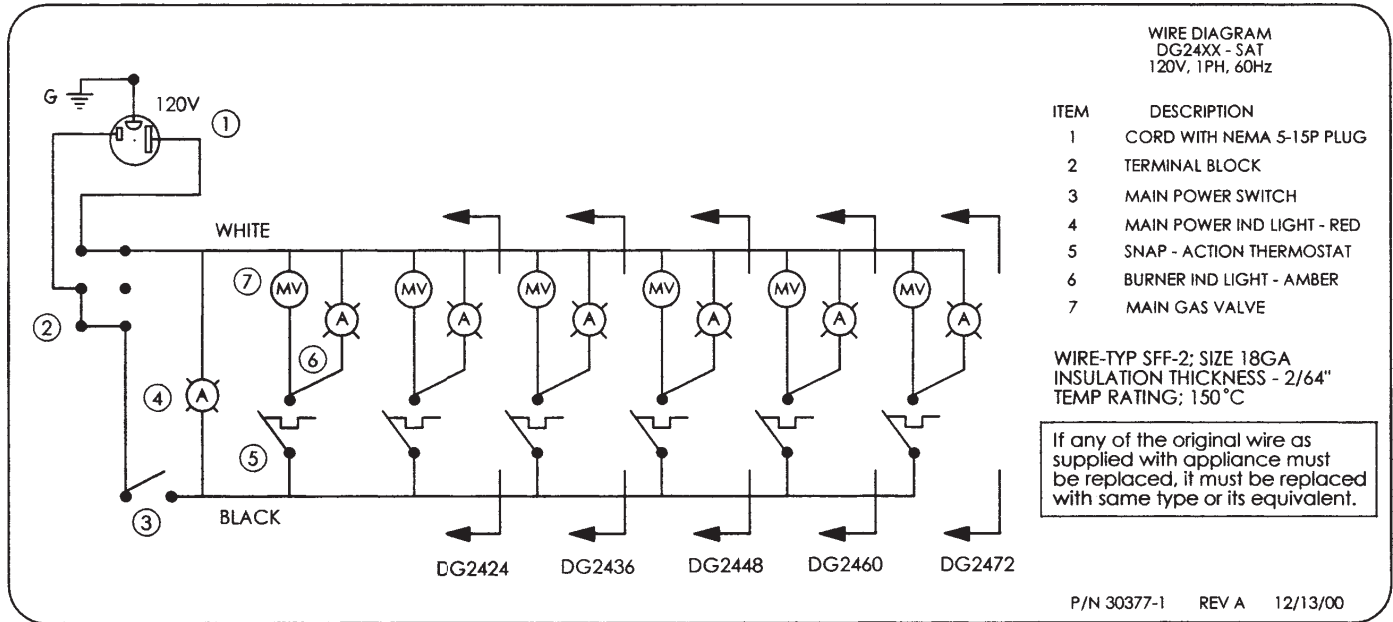

Griddles with standard snap-action thermostat.

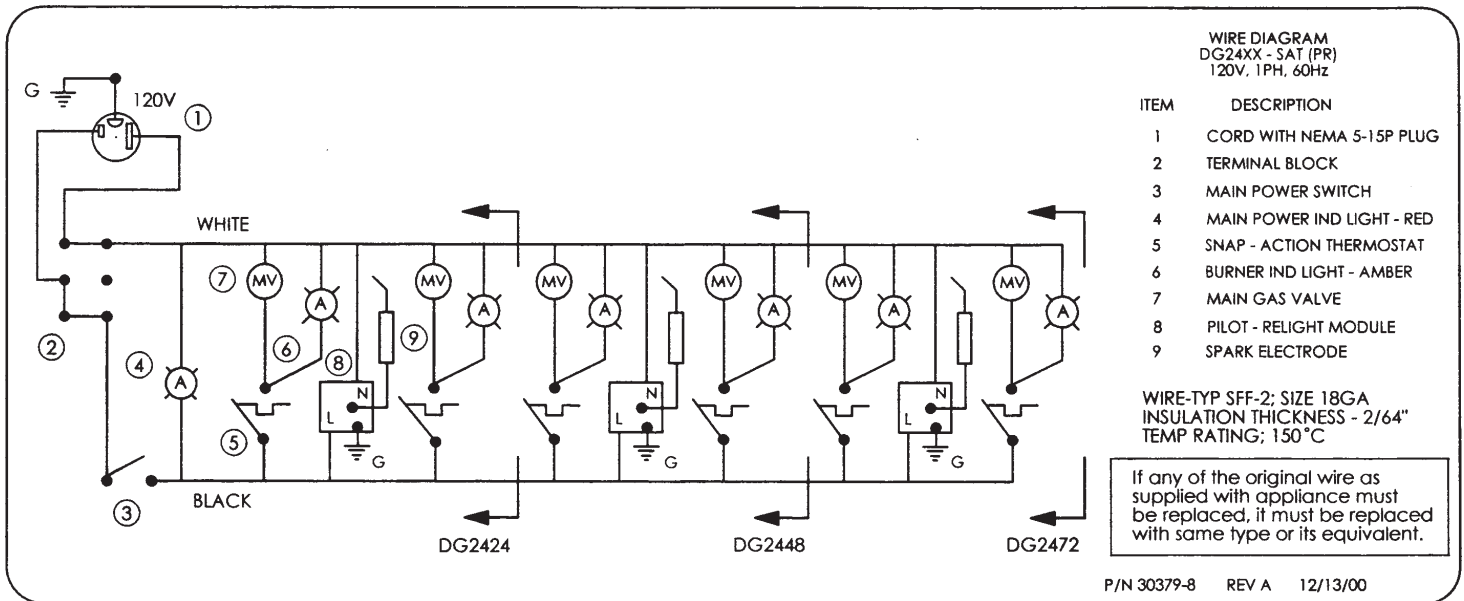

Griddles with snap-action T/stat and pilot relight option.

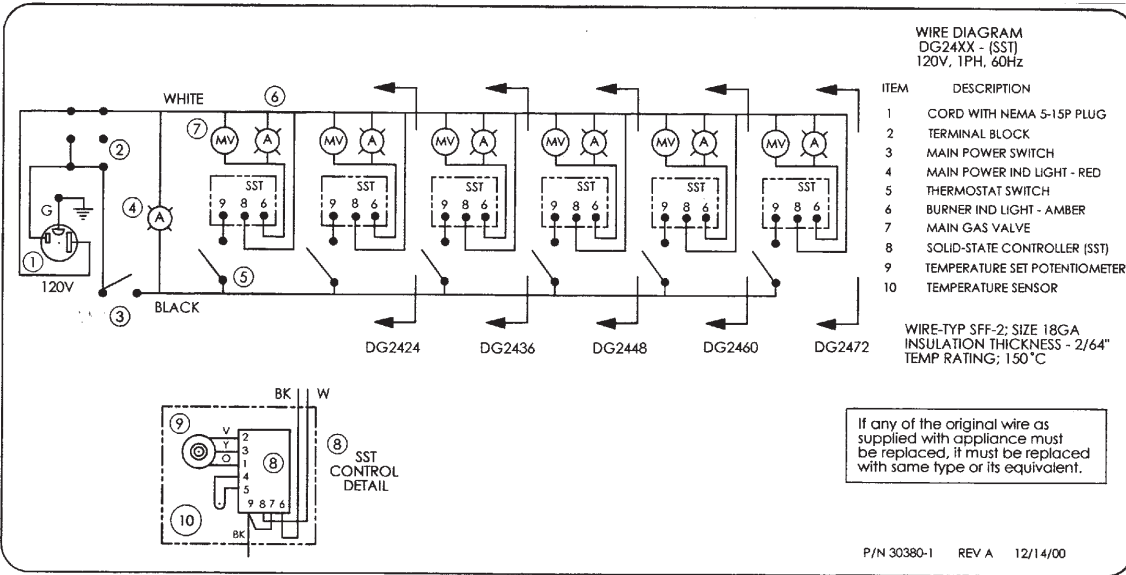

Griddles with solid-state T/stat.

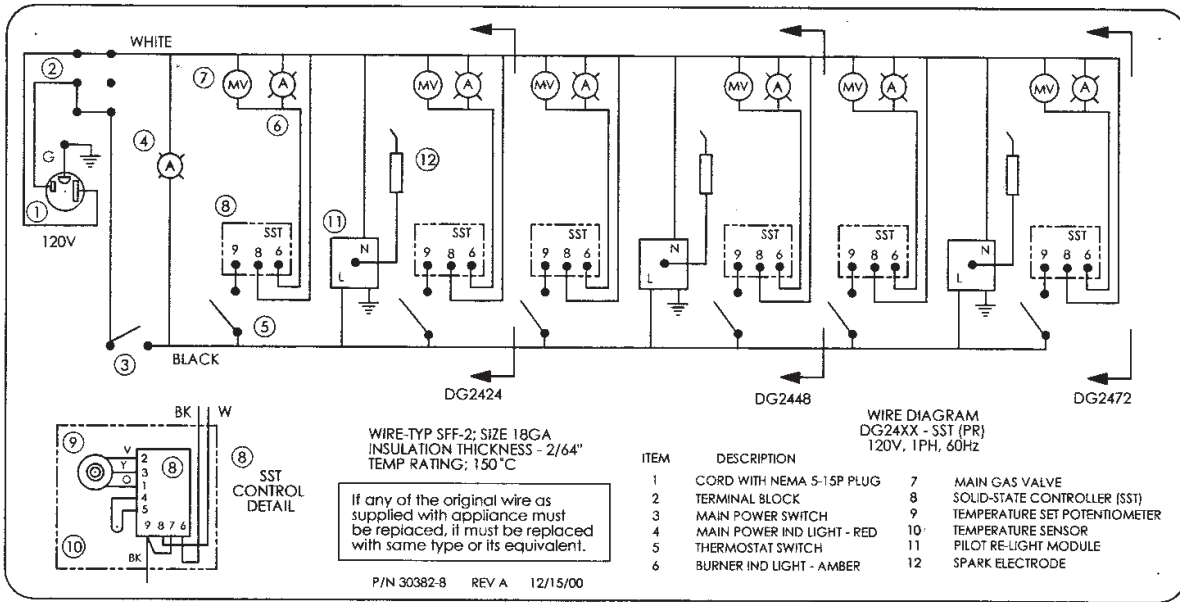

Griddles with solid-state T/stat and pilot relight option.

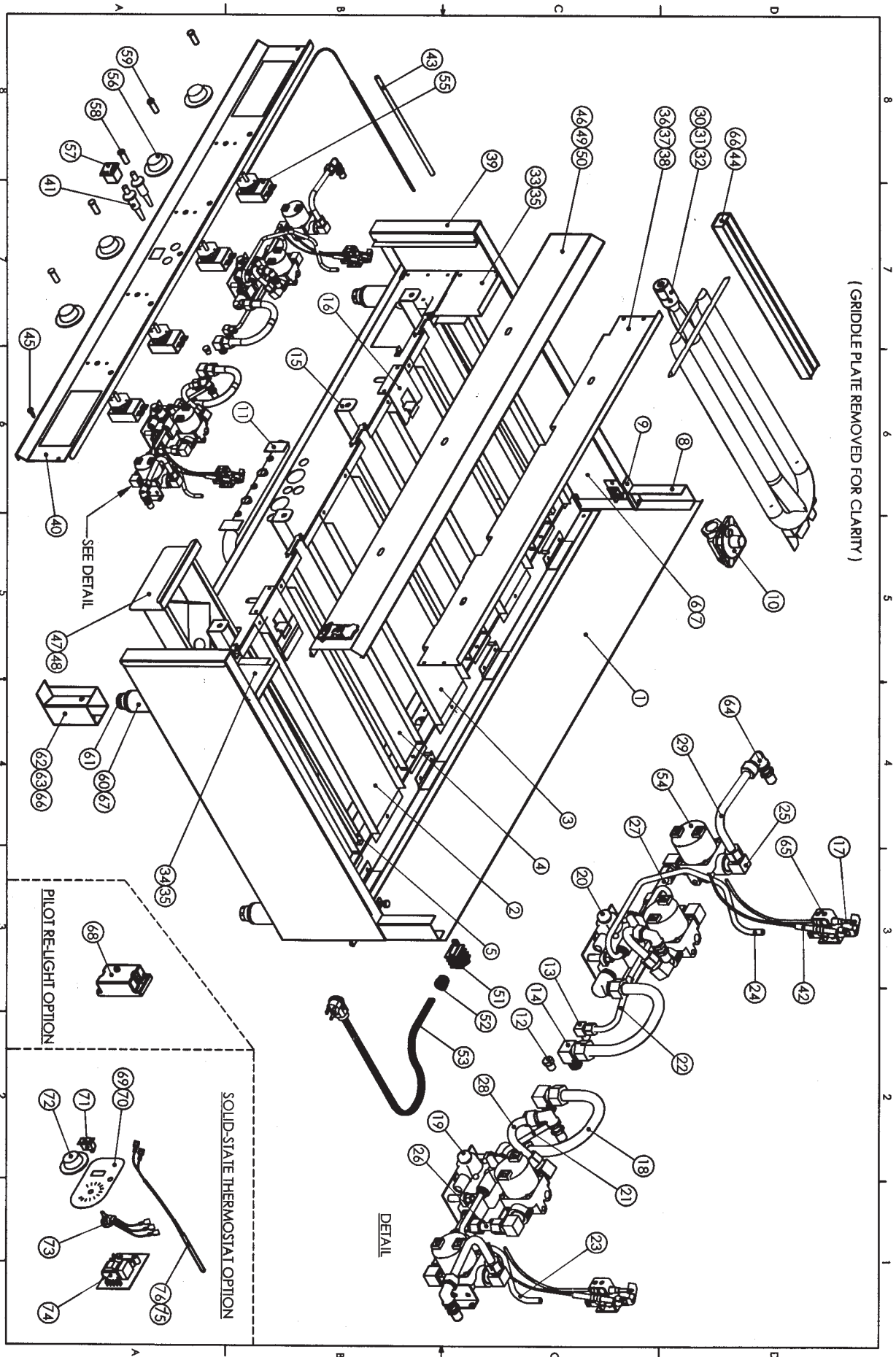

DELUXE GRIDDLE MODELS (SAT & SST) PARTS DIRECTORY

Item #	Part #	Description
1	**	FLUE BACK PANEL
2	30255-4	CENTER AIR BAFFLE W/ PILOT
3	30121-3	CENTER AIR BAFFLE-SOLID
4	30122-1	LOWER AIR BAFFLE-BURNER
5	30124-8	GREASE CONTAINER GUIDE
6	29087-4	LT SIDE AIR BAFFLE
7	30125-6	RT SIDE AIR BAFFLE
8	30224-4	FLUE POST (EG)
	30717-3	FLUE POST (SS)
9	30483-2	LEVELING BRACKET
	01869-4	LEVELING BOLT
10	14605-6	PRESSURE REGULATOR-NAT
	01040-5	PRESSURE REGULATOR-PROP
11	**	MANIFOLD ASSY
12	01279-3	HEX PLUG-1/8 NPTM
13	28532-3	ELBOW-1/8 NPTM X 1/4 CC (ALL)
14	30274-0	ELBOW-3/8 NPTM X 1/2 CC (ALL)
	30275-9	ELBOW-3/8 NPTM X 3/8 CC (2460-LT)
15	29077-7	FRONT BURNER SUPPORT
16	29088-2	PILOT BRACKET-J641DYA
17	01013-8	THERMOCOUPLE
18	30465-4	TUBING-FORMED-"U" 1/2 OD (ALL)
	30938-9	TUBING-FORMED-"U" 1/2 OD (2424 ONLY)
	30917-6	TUBING-FORMED-"U" 3/8 OD (2460-LT)
19	30639-9	SAFETY VALVE ASSY-RT OUTLET
20	30640-1	SAFETY VALVE ASSY-LT OUTLET
	30769-6	SAFETY VALVE ASSY-LT (2436, 2460)
21	30743-2	1/4 OD TUBING-MFLD/SAF (RT)
22	30749-1	1/4 OD TUBING-MFLD/SAF (LT)
	30940-0	1/4 OD TUBING-4 5/8 STRAIGHT-(2424)
	30750-5	1/4 OD TUBING-MPLD/SAF (LT)-(2436)
23	30751-3	1/4 OD TUBING-PILOT/SAF (RT)
24	30752-1	1/4 OD TUBING-PILOT/SAF (LT)
	30754-8	1/4 OD TUBING-PILOT/SAF (LT)-(2436)
25	30275-9	ELBOW-3/8 NPTM X 3/8 CC
26	30761-0	3/8 OD TUBING X 1 3/4 IN.
27	30762-9	3/8 OD TUBING X 2 1/4 IN.
	30941-9	3/8 OD TUBING X 2 3/4 IN. (2460)
28	30731-9	3/8 OD TUBING SOL/BURN "C"
29	30730-0	3/8 OD TUBING-SOL/BURN "L"
30	30368-2	BURNER ASSY-RIGHT
31	29021-1	BURNER ASSY-MIDDLE
32	30369-0	BURNER ASSY-LEFT
33	30164-7	HEAT SHIELD-LEFT
34	30165-5	HEAT SHIELD-RIGHT
35	30280-5	INSULATION-5" X 5"
36	**	CENTER HEAT SHIELD

DELUXE GRIDDLE MODELS (SAT & SST) PARTS DIRECTORY

Item #	Part #	Description
37	**	CENTER INSULATION-PUNCHED
38	30714-9	MOUNTING WASHER
39	30933-8	TRIMASSY, FRONT-LT
	30934-6	TRIMASSY, FRONT-RT
40	**	PANEL, CONTROLASSY
41	25716-8	PIEZO IGNITOR
42	30763-7	SPARK ELECTRODE
43	30295-3	INSULATION SLEEVE-12"
44	03386-3	SENSING BULB HOLDER ASSY
45	01918-6	SCREW, CONTROL PANEL
46	**	PANEL, FRONT-UPPER
47	30144-2	GREASE DRAWER
48	30764-5	GREASE DRAWER BAFFEL
49	16100-4	SMALL CHEF
50	02639-5	RETAINER CLIP
51	08584-7	TERMINAL BLOCK
52	01395-1	STRAIN RELIEF BUSHING
53	01409-5	6' GROUNDED CORD & PLUG
54	29024-6	SOLENOID VALVE, 120V
55	29023-8	THERMOSTAT 150-450F
56	30294-5	THERMOSTAT DIAL
57	19116-7	MAIN ON/OFF SWITCH
58	17150-6	INDICATOR LIGHT, RED
59	17045-0	INDICATOR LIGHT, AMBER
60	30305-4	SS LEG W/ FOOT-OUTER
61	30936-2	SS LEG W/ FOOT-MIDDLE (2460, 2472)
62	30257-0	SPOUT ASSY-RT
63	30937-0	SPOUT ASSY-LT
64	22903-2	ORIFICE ELBOW-#42 DS (NAT)
	30503-0	ORIFICE ELBOW-#52 DS (PROP)
65	30286-4	PILOT BURNER-# .021 DS (NAT)
	30504-9	PILOT BURNER-# .010 DS (PROP)
66	01860-0	THUMB SCREW
67	30619-3	SET SCREW, 1/4-20
68	28757-1	PILOT REIGNITER-120V
69	30615-0	SS OVERPLAY-RIGHT
70	30618-4	SS OVERPLAY-LEFT
71	17149-2	ON/OFF MINI-SWITCH
72	24663-8	SS THERMOSTAT DIAL
73	25377-4	POTENTIOMETER W/48 IN LEADS
74	25375-8	CONTROLLER, SS-120,208-230V
75	25376-6	SENSOR BULB
76	01758-2	INSULATION SLEEVING-PER FT

**EXACT MODEL NUMBER REQUIRED TO IDENTIFY CORRECT PART.

WARNING

If not installed, operated and maintained in accordance with the manufacturer's instructions, this product could expose you to substances in fuel or in fuel combustion which can cause death or serious illness and which are known to the State of California to cause cancer, birth defects or other reproductive harm.

The State of California enacted the California Safe Drinking Water and Toxic Enforcement Act of 1986, (Prop. 65), which "prohibits any person in the course of doing business from knowingly and intentionally exposing any individual to a chemical known to the State of California to cause cancer or reproductive toxicity without first giving clear and reasonable warning to such individuals." The Governor's Scientific Advisory Panel added carbon monoxide to the list of hazardous chemicals known to cause reproductive harm.

In order to establish full compliance with Proposition 65, we attached a yellow warning label to each gas fired unit manufactured by the Montague Company.

Carbon monoxide would not be present in concentrations that would pose a "significant risk" to the consumer when the equipment is installed, operated and maintained as follows:

1. Installed in accordance with all local codes, or in the absence of local codes, with the current National Fuel Gas Code Z223.1.
2. Installed under a properly designed and operating exhaust hood.
3. Connected to the type of gas for which the unit is equipped.
4. Proper appliance pressure regulator installed on the gas supply line and adjusted for the manifold pressure marked on the rating plate.
5. Adequate air supply to the unit.
6. The equipment is operated in the manner intended using the proper utensil for that type of appliance.
7. Keep the equipment clean and have it checked periodically.
8. Burner air adjustments, mechanical maintenance and repairs should be performed by qualified service personnel.

If the equipment is not installed, operated and maintained in accordance with the above, concentrations of carbon monoxide in excess of the established limits could present in the kitchen environment.

ALL PERSONNEL IN THE WORKPLACE WHO MAY BE SUBJECT TO ANY EXPOSURE OF CARBON MONOXIDE MUST BE WARNED OF SUCH POSSIBLE EXPOSURE. THIS WARNING SHOULD BE CONVEYED IN A MANNER SO THAT IT IS CLEARLY UNDERSTOOD BY THE EMPLOYEE, AND THE EMPLOYEE SHOULD BE ASKED IF IN FACT HE OR SHE UNDERSTANDS THE CORRECT METHOD OF OPERATION OF THE EQUIPMENT AND THAT A RISK OF EXPOSURE EXISTS IF THE EQUIPMENT IS OPERATED IMPROPERLY.



THE MONTAGUE COMPANY

1830 Stearman Avenue, P.O. Box 4954, Hayward, CA 94540-4954

IMPORTANT

When ordering parts, to eliminate mistakes and facilitate delivery, always give the following information:

Serial No. _____

Model No. _____

Change No. _____

Name & No. of Part

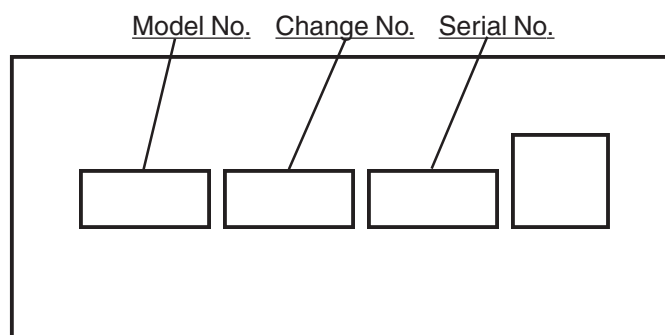

"DG" Series Rating Plate

The Montague Company
1830 Stearman Avenue
P.O. Box 4954
Hayward, CA 94540-4954

P/N 30416-6 01/01