

INSTRUCTION MANUAL

MONTAGUE **VECTAIRE**

Electric Convection Ovens

Models: EK15A, 2EK15A, EK8(N,O), 2EK8(N,O)

These instructions should be read thoroughly before attempting installation. Set up and installation should be performed by qualified installation personnel.

Keep area around appliances free and clear from combustibles.

**PLEASE RETAIN THIS MANUAL
FOR FUTURE REFERENCE.**



THE MONTAGUE COMPANY

1830 STEARMAN AVENUE, P.O. BOX 4954

HAYWARD, CA 94540-4954

TEL: 510/785-8822 FAX: 510/785-3342

CONTENTS

	Page
1. Installation	
Shipping Damage.....	1
Assembly.....	1
Leveling.....	4
Electrical Connection.....	5
2. Operation	
Operating Instructions.....	8
Special Instructions for Continuous Clean..	11
Interior.....	11
3. Baking Hints	
General Information.....	14
Cooking Hints.....	14
Meat Roasting.....	15
General Baking.....	15
Time and Temperature Chart.....	16
Baking Difficulties and Probable Causes....	18
4. Maintenance	
General Cleaning.....	20
Cleaning Stainless Steel.....	21
5. Service	
Main Circuit Breaker.....	24
Upper Control Panel.....	24
Thermostat.....	25
Timer.....	28
Fuses and Lights.....	29
Wiring Diagrams.....	30
Parts Ordering Information.....	34
Limited Warranty.....	Inside Back Cover
Renewal Parts Drawing.....	Insert

1. INSTALLATION

The Vectaire electric convection ovens are manufactured for use on the electric supply indicated on the rating plate located on the front of the hinged timer panel. Units wired for three (3) phase service CAN NOT be changed to single phase or single phase units changed to three (3) phase.

Units designated for 208 VAC will operate satisfactorily within the voltage range of 197 to 219 VAC. Units designated 230 VAC will operate satisfactorily within the voltage range of 220 to 240 VAC.

THE OVEN(S) MUST BE INSTALLED IN ACCORDANCE WITH ALL LOCAL AND STATE CODES.

The Vectaire ovens are produced with the best possible materials and workmanship. Proper installation is vital if safe operation and best performance are to be achieved.

CAREFULLY READ AND FOLLOW THESE INSTRUCTIONS

CHECK FOR SHIPPING DAMAGE

Check carton for handling damage. After carefully uncrating oven, check for "concealed" damage. Notify transportation company or carrier immediately, and file "Concealed Damage" claim with them. Be sure to retain container for their inspection.

ASSEMBLY

Uncrate oven and base as near final location as possible. Remove all packing material and accessories from oven interior.

MODEL EK-15A

ENCLOSED BASE: Install rack guides (If provided) in base. Place oven on base as shown in Figure 2. Install door handle and secure with screws that are provided.

INSTALLATION OF RACK GUIDES IN BASE - Kit No. 04651-5 (If Provided See Fig.1)

1. Set base upright and place one rack guide in position with rod extensions toward rear and through holes in back.
2. Install stop (B) behind vertical flange forming base opening.
3. Place screw through clamp (A), upper hole of base flange and stop (B). Install nut.
4. Repeat step 3 with lower hole of flange and stop. Tighten both nuts.
5. Repeat step 2, 3 and 4 for installation of other rack guide on opposite side.

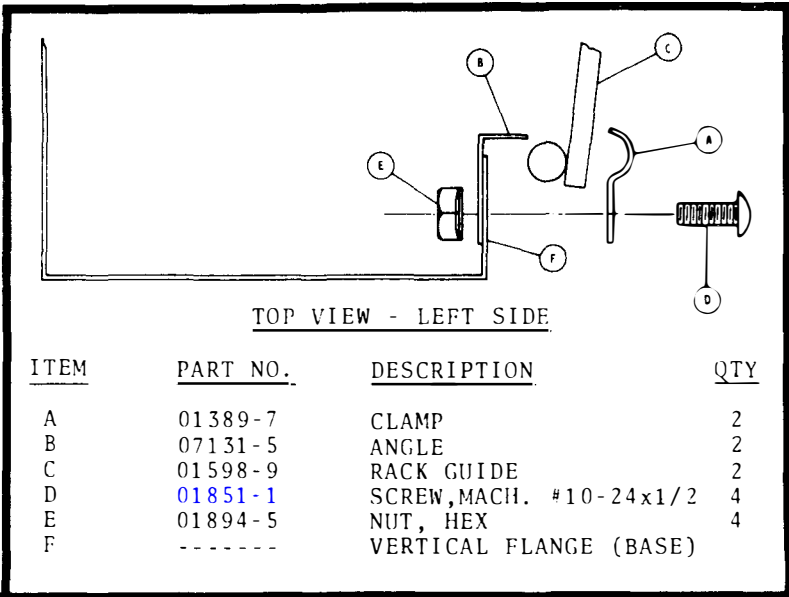

Fig. 1

MODULAR STAND: Turn modular stand frame upside down. Insert a leg into each socket (4) and firmly tighten all wing screws. Set modular stand in desired location of oven. Place oven section on stand and position oven so that locator tabs on stand engage oven bottom frame. (See Fig. 3)

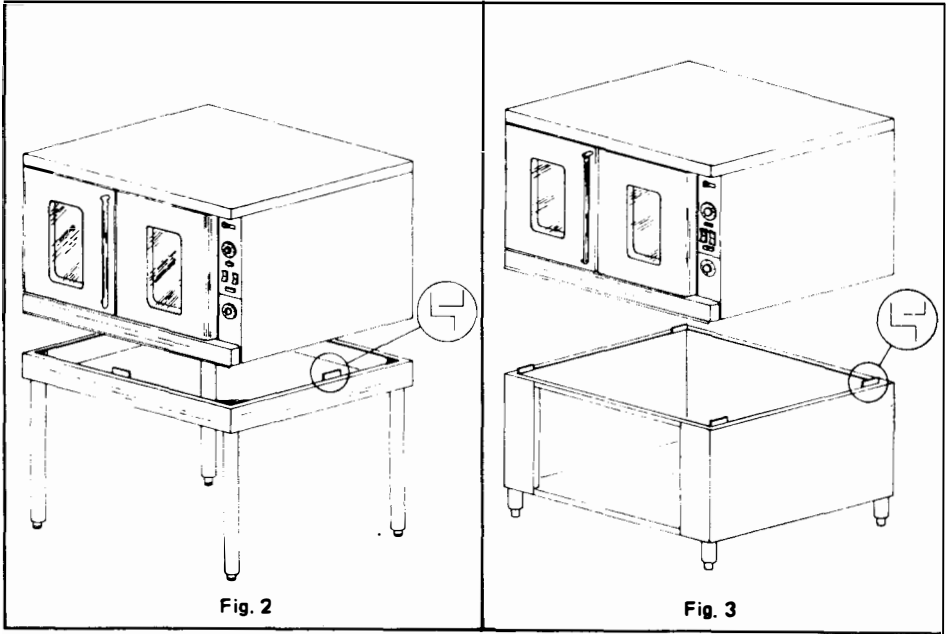

Fig. 2

Fig. 3

Model EK-15R (Roll-In Oven)

Raise oven and insert leg into each socket (4) located in oven bottom frame. Secure leg to socket by tightening all wing screws. Set oven in desired location.

Model 2EK-15A

Turn modular stand frame upside down. Insert a leg into each socket (4) and firmly tighten all wing screws. Set modular stand in desired location of oven. Place bottom oven section on stand and position oven so that locator tabs on stand engage oven bottom frame. Place top oven section on lower unit and position so that locator tabs on lower unit engage oven bottom frame. (See Fig.4)

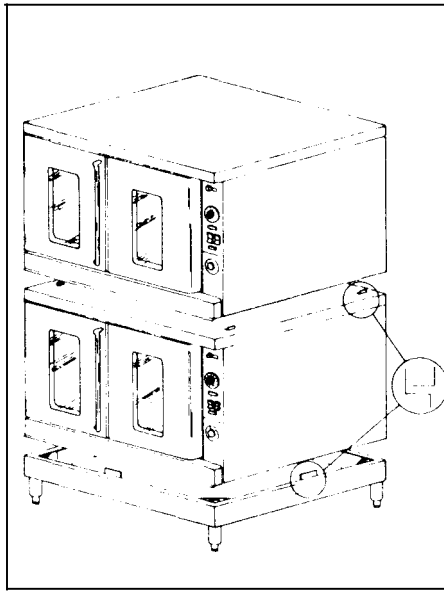

Fig. 4

Remove screws from side of moisture vent outlet on back of each oven section. Place duct over outlets and attach with these same screws.

Model 2EK-15RF (Roll-In Oven)

Screw the adjustable feet of the legs in all the way. Raise the oven and screw the complete leg assembly into mounting holes located at each corner of oven bottom frame. Turn until leg flange is tightly seated against bottom frame. Set oven in desired location.

Depending upon type of floor, it may be necessary to fasten two legs of the oven to the floor to keep the oven stationary.

IF OVENS ARE TO BE PLACED AGAINST A REAR WALL, THE TOP AND BOTTOM MUST BE LEFT OPEN TO ALLOW AIR CIRCULATION AROUND MOTOR(S).

LEVELING

Model EK-15A and 2EK-15A : When oven is in permanent position, level entire unit(s) by placing

spirit level on oven bottom and adjusting the foot on the bottom of each leg so that oven is level from front-to-back and side-to-side.

Model EK-15R and 2EK-15R (Roll-In Oven)

When oven is in permanent position, roll the empty cart into the oven. The cart should roll into recess in oven without any "drag" or scraping. Adjust the foot on each leg with cart in place in the oven. The gap between the top of cart and top of oven recess should be as small as possible (without dragging) to prevent air leakage from oven. (See Fig. 5)

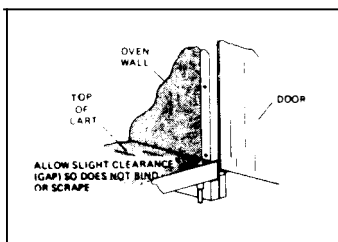



Fig. 5

ELECTRICAL CONNECTION

Before making any electrical connections to the unit, check the rating plate which is located on the hinged timer panel to make sure that the oven is being connected to the proper electrical supply. Units marked "208V" will operate satisfactorily from 197 - 219 VAC. Units marked "230V" will operate satisfactorily from 220-240 VAC.

			
THE MONTAGUE Co.			
HAYWARD		CALIFORNIA	
MODEL NO	SERIAL NO.		
CHANGE NO	VOLT		
MAX KW	PHASE		
MAX AMP/LEG	CY	60	

UNITS WIRED FOR THREE (3) PHASE SERVICE CAN NOT BE CHANGED TO SINGLE PHASE, OR SINGLE PHASE UNITS CHANGED TO THREE (3) PHASE.

USE COPPER WIRE ONLY FOR POWER CONNECTION(S)

Models EK-15 (A, R) and 2EK-15A (See Fig. 6)

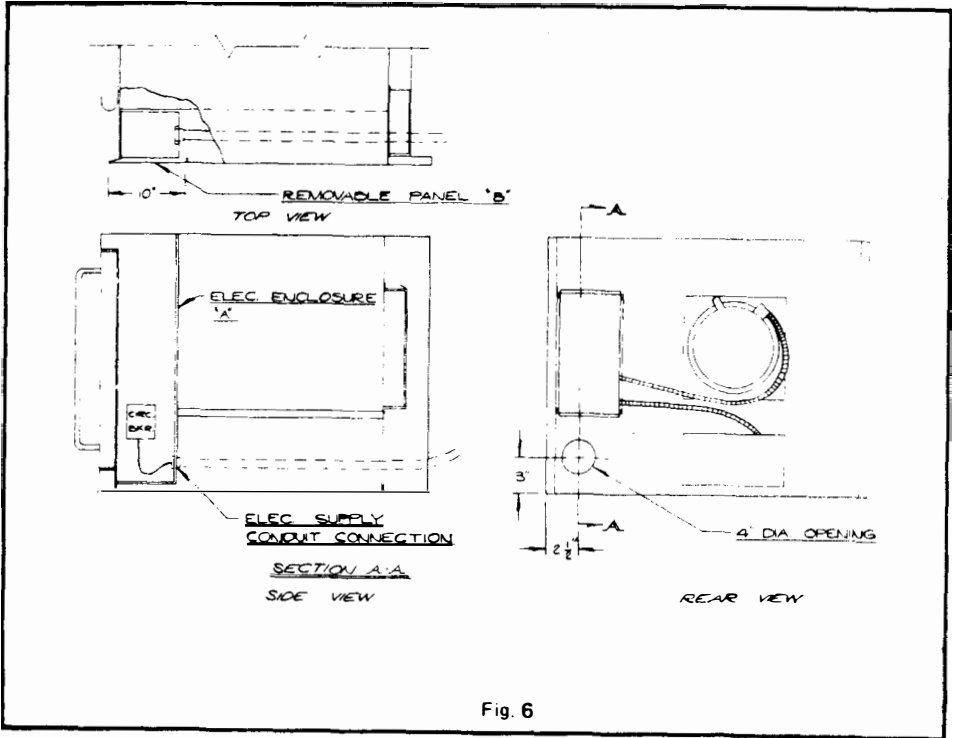

Fig. 6

The electrical supply connection to the unit is made at the lower terminals of the circuit breaker. The electrical supply conduit is fed thru the 4" dia. opening in back of oven and connected to rear panel of the electrical enclosure "A".

For access to electrical supply connection terminals, remove bottom panel below circuit breaker located behind the hinged timer panel. For access to conduit connection, remove the front portion of the right side panel "B".

The Model 2EK-15A (double deck ovens) requires a separate electrical supply to each oven section.

Model 2EK-15RF (Roll-In Oven)

The electrical supply connection to the unit is made at the left terminals of the circuit breaker. The electrical supply conduit is fed thru the left top

rear of oven and connected to the the rear panel of the electrical enclosure.

For access to electrical supply connection terminals and conduit connection, remove the left panel located behind the hinged front panel.

THE OVEN(S) MUST BE WIRED TO GROUND. USE GREEN COLORED SCREW THAT IS PROVIDED INSIDE ELECTRICAL ENCLOSURE FOR THIS PURPOSE.

2. OPERATION

THIS APPLIANCE HAS BEEN CLASSIFIED AS
COMMERCIAL COOKING EQUIPMENT AND MUST
BE OPERATED BY PROFESSIONAL PERSONNEL

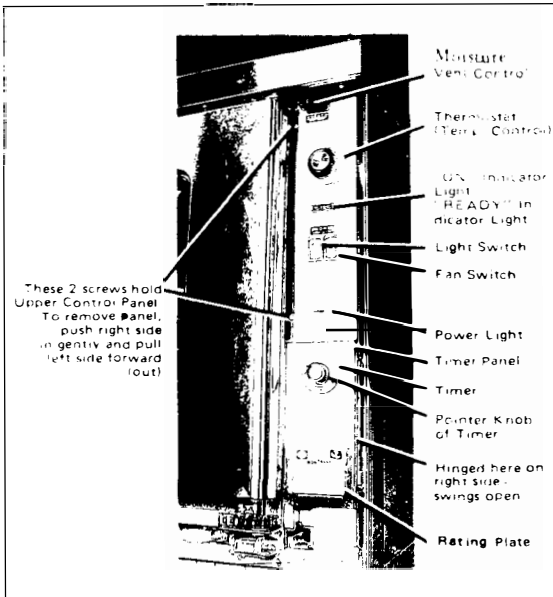

Fig. 7

OPERATION INSTRUCTIONS— MODEL EK-15A; MODEL 2EK-15A (See Fig. 7)

Be sure power is "ON" at the main panel box. Open the hinged "Timer Panel" at lower right front of oven. Turn breaker switch to "ON" to energize controls.

Press fan switch to "ON". Set the thermostat to the desired temperature. The heating elements are controlled by the thermostat, and will not operate unless the fan

is running. Until the temperature setting is reached, the "ON" side of indicator light will glow. When temperature setting is reached, "READY" side will glow. The indicator light will change back to "ON" as the oven cools and thermostat calls for more heat.

Opening the oven doors will cause the fan and heating elements to shut off. They will automatically resume operation when the doors are closed. Do not attempt to cook until the "READY" light is on.

To load the oven: Open doors and load quickly and evenly, leaving space around each item for air circulation. Close doors immediately. Set the mechanical timer to desired cooking time. (If less than 10 minutes, turn the dial past 10, then back to proper setting). Never turn past 60 as this will damage the timer mechanism. When time has elapsed bell will ring, but it will not shut off the oven. For a longer "ring" turn the timer knob to 60, then back to the desired setting. The oven lights may be turned "ON" or "OFF" at any time by pressing the light switch.

OPERATION INSTRUCTIONS—MODEL EK-15R

Roll-In units will not operate without a cart in the oven. When the cart is in position close oven door, replace cart handle in the lower socket. Press the fan switch to "ON" and turn thermostat dial to desired temperature setting. (Heating elements will not operate unless the fan is running). The "ON" side of the indicator light will glow until the oven reaches temperature and then will change to "READY" side. The light will change from "READY" to "ON" as the oven cools and more heat is required.

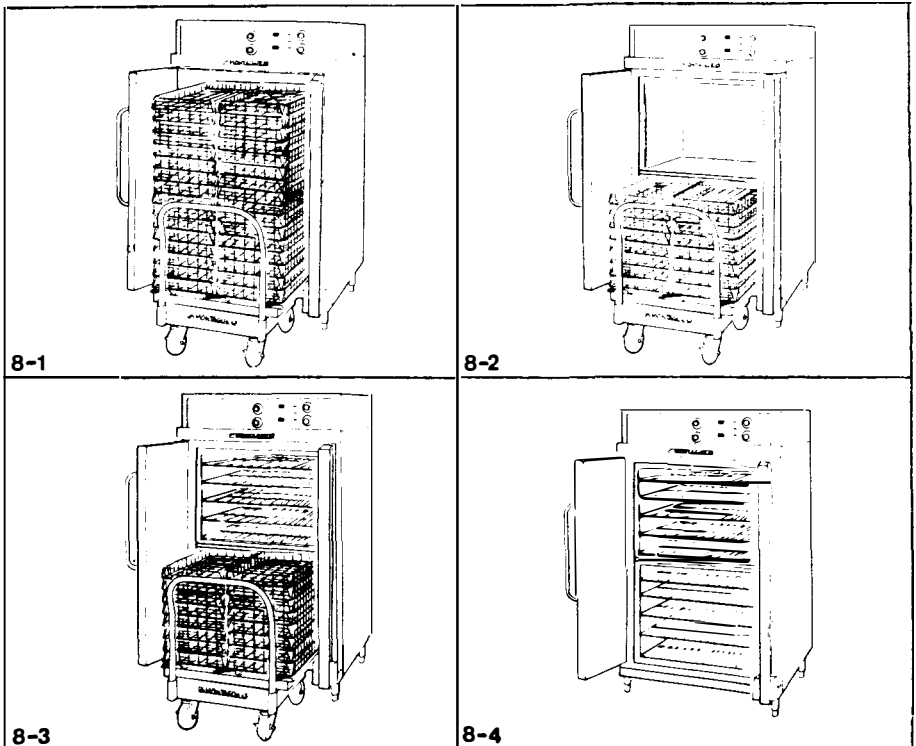

To load the oven: Remove empty cart and insert loaded cart. (This should be done as rapidly as possible to prevent loss of heat while doors are open). Set mechanical timer for desired time. If less than 10 minutes, turn timer past 10, then back to proper setting. The bell will ring when the "set" time has elapsed, but this will not shut off the oven. For a longer "ring" turn the dial to 60, then back to the proper setting. Never turn the timer dial beyond 60 as it will damage the mechanism. To turn oven lights "ON" or "OFF" simply depress the light switch.

OPERATION INSTRUCTIONS— MODEL 2EK-15RF (See Fig.8)

Important: This unit can be operated as:

1. A double Roll-In oven
2. A single Roll-In oven
3. A combination Roll-In and Bake/Roast oven
4. A double Bake/Roast oven

OPERATION AS DOUBLE ROLL-IN OVEN (See Fig. 8-1)

Roll the empty cart into the oven. Remove handle. Close doors. Turn fan switch to "ON" position. "ON" indicator will light and the fan motors and heating elements will start. If motors fail to start, check circuit breakers behind control panels. Set both thermostats to desired temperature. The oven "READY" lights will glow when the temperature is reached (about 10 to 15 minutes without compartment divider). When temperature is reached, remove the empty cart and roll in loaded cart immediately. Remove handle. Close doors. Set timer(s) to the desired cooking time.

OPERATION AS SINGLE ROLL-IN OVEN (See Fig. 8-2 & 8-3)

Insert the compartment divider. Follow the above instructions. (When using the lower compartment only, the top oven may be left "OFF").

With the compartment divider in place, position rack guides and racks in the top compartment. Roll in cart as above. Set each thermostat for the desired temperature.

OPERATION AS DOUBLE BAKE/ROAST OVEN (See Fig. 8-4)

With rack guides and shelves placed on the cart follow foregoing instructions.

SPECIAL INSTRUCTIONS FOR OPTIONAL "CONTINUOUS CLEAN" INTERIOR

IMPORTANT: If your oven is equipped with the optional "Continuous Clean" interior, read the following carefully before operating.

WHAT IS NEW ABOUT THE INSIDE OF YOUR OVEN?

The exposed interior surfaces of "Continuous Clean" ovens are coated with a remarkable substance. It can readily be identified by its dark brown and white speckled finish. This new coating is endowed with a unique cleaning ability that causes food and grease spatters to gradually clean away automatically when exposed to normal even temperatures.

HOW "CONTINUOUS CLEAN" OVENS WORK

The special coating contains an ingredient that reduces the temperature at which grease will incinerate. Therefore, the normal heating of an oven will cause the self-destruction of these waste products. This cleaning action is a CONTINUOUS PROCESS during normal cooking operations.

"BREAK-IN" PERIOD

When the oven is new and, before you do any cooking, operate the oven empty for at least two hours at high heat (500° F). For the first week or two always preheat oven in this manner. During this "conditioning" period it is especially important that the oven surfaces be kept clean of any excessive soiling due to spillovers or spatters.

HOW TO PUT "CONTINUOUS CLEAN" ACTION TO WORK

Each day, after baking and roasting operations have been completed, empty the oven. Then turn the temperature control up to high heat. This high heat will speed up the cleaning action and reduce the time required to clean the oven effectively. The cleaning time necessary will depend upon the "soil" condition in the oven. As a general practice, allow from 45 to 60 minutes.

HEAVY STAINING

When the oven appears soiled due to heavy staining, we suggest preheating the empty oven each day for one to two hours for most effective results. Also, ordinary household ammonia has proved an effective method for removing baked-on build-up and in keeping the microscopic pores of the coating open and free to perform its cleaning action. Thus, an occasional light swabbing with household ammonia while the oven is at room temperature can prove to be extremely beneficial.

SPILLAGE

Excessive spillage or crust which is allowed to build up on oven interior surfaces will seriously retard the continuous cleaning action. It should be wiped away as soon as possible with a damp cloth. Baked-on spillage can be removed by applying Montague Oven Cleaner when the oven is warm.

PERIODIC "TUNE UP"

Although the oven may appear clean, we recommend operating the oven at high heat for approximately two hours once every month. This will prevent build-up of solids in hard-to-see places or in the pores of the coating. CAUTION: Never use abrasives, powders, harsh liquids, caustics or dyes as they may leave a film or residue that will clog the pores of the special coating, and retard the cleaning action.

DIFFICULT STAINS

Certain types of food may leave a stain that is slow to fade. These include flour-milk mixtures, sugar, macaroni and cheese, cream sauces, and blood. It may take a slightly longer time for the continuous cleaning action to clean this type of stain. Accelerate removal by using household ammonia while oven is at room temperature.

HEAVY BUILD-UP

If excessive soils or spillovers have become carbonized, remove the charred portion with a hard nylon brush. (Do not use steel or other metallic brushes or scouring pads). For any stubborn stain or "varnish" film, apply a good grade paste oven cleaner in the following manner: (1) With the oven at room temperature apply paste over the spill. (2) Allow to stand for 10-15 minutes (read instructions on label of product); then wipe up spill. (3) Reapply if not entirely removed (any film remaining over top of material will prevent self-cleaning action). (4) If necessary, apply Montague Oven Cleaner with a hard nylon brush. (5) Remove loosened particles with a damp cloth. NOTE: If available steam may be used. It is not harmful to the special coating. Always be sure to wipe up any excess water.

3. BAKING HINTS

GENERAL INFORMATION

These times and temperatures were especially prepared and tested for use in a Vectaire convection oven. Times, temperatures, and moisture contents may vary in other convection ovens. The suggested times and temperatures may vary considerably from those shown. They are affected by weight of load, recipe, type of pan, and calibration of thermostat. Differences in quality and age of meats and fowl and quantities of shortening, milk, fat and other ingredients in baked goods affect both cooking times and temperatures.

COOKING HINTS

- * Avoid recipes that would not be satisfactory in a regular conventional oven.

- * Times and temperatures will vary slightly with maximum to minimum oven loads.

- * Stagger pans in ovens as much as possible to allow the free flow of air.

- * Pans may be tightly sealed with sheets of aluminum foil. Do not let foil touch food.

- * Convection ovens usually save 1/4 to 1/3 of the total cooking time. Check product in one-half of the cooking time on recipe. Add additional time as needed.

- * For most products, use a maximum of 5 racks for optimum results.

- * For less browning, lower temperature; for more browning, increase temperature. If product cooks too quickly around the edges, lower temperature.

- * Level pans bake more evenly than warped pans.
- * Filling pans too full causes uneven baking.
- * When using frozen entrees, refrigerator-thaw for best results, and cover during cooking.
- * Load and unload food quickly. Close oven doors promptly.
- * Type pans used affect baking time and results. A light shiny pan reflects heat, a dark dull pan absorbs heat.
- * When baking fruit pies - use a baking pan on rack and set pie tins on top of pan. This will give better bottoms and also catch spillovers.

MEAT ROASTING

For best meat roasting results you have two choices. If the time factor is more important than shrinkage, roast at same temperature you would use in conventional oven. Considerable time savings will be realized; however, shrinkage will be normal. For minimum shrinkage on beef roasts to 10 lbs., use setting of 275^o. On larger roasts use 200^o for first hour, 225^o for second hour and 275^o until done. Shrinkage may be reduced further by placing pan of water in bottom of oven.

GENERAL BAKING

In order to obtain even browning and maximum efficiency, it is absolutely necessary to use lower temperatures than in a conventional oven. As a rule of thumb, we recommend a reduction of 50^o.

COOKING CHARTS ARE GUIDES: These charts have been compiled carefully. However, you may want to cook certain foods a little more or a little less according to your preference and your recipe. Also types and sizes of pans influence baking time and temperatures.

For example: Cupcakes need much less time to bake than loaf or layer cakes. Also with a shiny roasting pan, meats take more time to roast than with a dark roasting pan.

TIME AND TEMPERATURE CHART

Food	Temperature (degrees Farenheit)	Portion Size or Total Size	Time Uncovered	Time Covered
BREAD, BAKERY				
Bread, 1 lb. loaf	340	1 lb.	30 min.	
Hamburger Rolls	300		15 min.	
Corn Bread(Northern)	335		25 min.	
Corn Bread(Southern)	375		15-20 min.	
Yeast Rolls	325		25 min.	
Baking Soda Biscuits	400		6 min.	
Raw pies, frozen	400	10" 2 lb. 11 oz.	30 min.	
Fruit pies	350	46 oz. (B)	45-50 min.	
Berry pies	350	22 oz. (B)	35 min.	
Fruit pies	375		30 min.	
Fresh apple	350-375	20 oz. (B)	25-30 min.	
Pumpkin pie	250		25-30 min.	
Custard pie	250		25-30 min.	
Meringue pie	350		4 min.	
Apple turnover	350	3" triangle	20 min.	
Fruit cobbler	350-375	20 x 12 x 2"		
Chocolate Cake	325		20 min.	
Sheet Cake	325	5 lbs/1" Hi pan	16-18 min.	
Chocolate Layer Cake	350	25 - 9" shell	18 min.	
Strawberry Layer Cake	350	25 - 9" shell	20 min.	
Yellow Layer Cake	350	25 - 9" shell	14 min.	
Fruit Cake	275		70 min.	
Angel Cakes	250		25 - 30 min.	
Sugar Cookies	300		15 min.	
Chocolate Chip Cookies	375	18 x 26"	7 1/2 min.	
Cherry Crisp	300		25 min.	
Cinnamon Buns	335		20 min.	
Brownies	300			
Danish	335		12 min.	
Cream Puffs	350		20-25 min.	
Sweet Rolls	400	18 x 26"	20 min.	
Pizza in pans	475	13"	6 min.	
FROZEN TV TYPE MEALS				
Breakfast	325	10 oz.		14 min.
Scrambled eggs				
Sausage patty				
Potatoes				
Dinner TV Type Pkg.	350-375	17-1/2 oz		14 min.
Meat loaf				
Spinach				
Beans				
Lasagna	400	for 200, 2" deep		60 min.
Lasagna, thawed	425	for 200, 2" deep	5 min.	25 min.

EK - 15A SERIES VECTAIRE ELECTRIC CONVECTION OVEN			QUANTITY				
			1 PHASE		3 PHASE		
			208V	220V 240V	208V	220V 240V	480V
Item No.	Part No.	Description					
45		Keeper; Door Bearing	2	2	2	2	2
46		Plate; Spacer	1	1	1	1	1
47		Pad; Insulation - Motor	1	1	1	1	1
48		Plate; Rear Motor Mounting	1	1	1	1	1
49		Bolt; Motor Mounting 3/16" x 1 1/2"	4	4	4	4	4
50		Baffle; Rear Fan, Porcelain Enamel	1	1	1	1	1
51		Bracket; Fan Baffle Support	2	2	2	2	2
52		Deflector; Air	1	1	1	1	1
53		Cover; Plate	1	1	1	1	1
54		Element Brackets	4	4	4	4	4
55		Cover; Moisture Vent	1	1	1	1	1
56		Guard; Capillary Tube	1	1	1	1	1
57		Oven Bottom	1	1	1	1	1
58	V-41-1	Guide; Rack - Left (Right Not Shown)	2	2	2	2	2
59	V-40-1	Rack; Oven - STD	-	-	-	-	-
60		Cover; Light Box	1	1	1	1	1
61		Cover; Electrical Enclosure	1	1	1	1	1
62		Cover; Element Terminal	1	1	1	1	1
--		Transformer (Not Shown)	0	0	0	0	1
		Wiring Assembly (Specify Voltage & Phase)					

2-EK-15A TWO OVENS STACKED DOUBLE QUANTITIES SHOWN ABOVE.

* Specify Electrical Voltage

△ Specify Finish

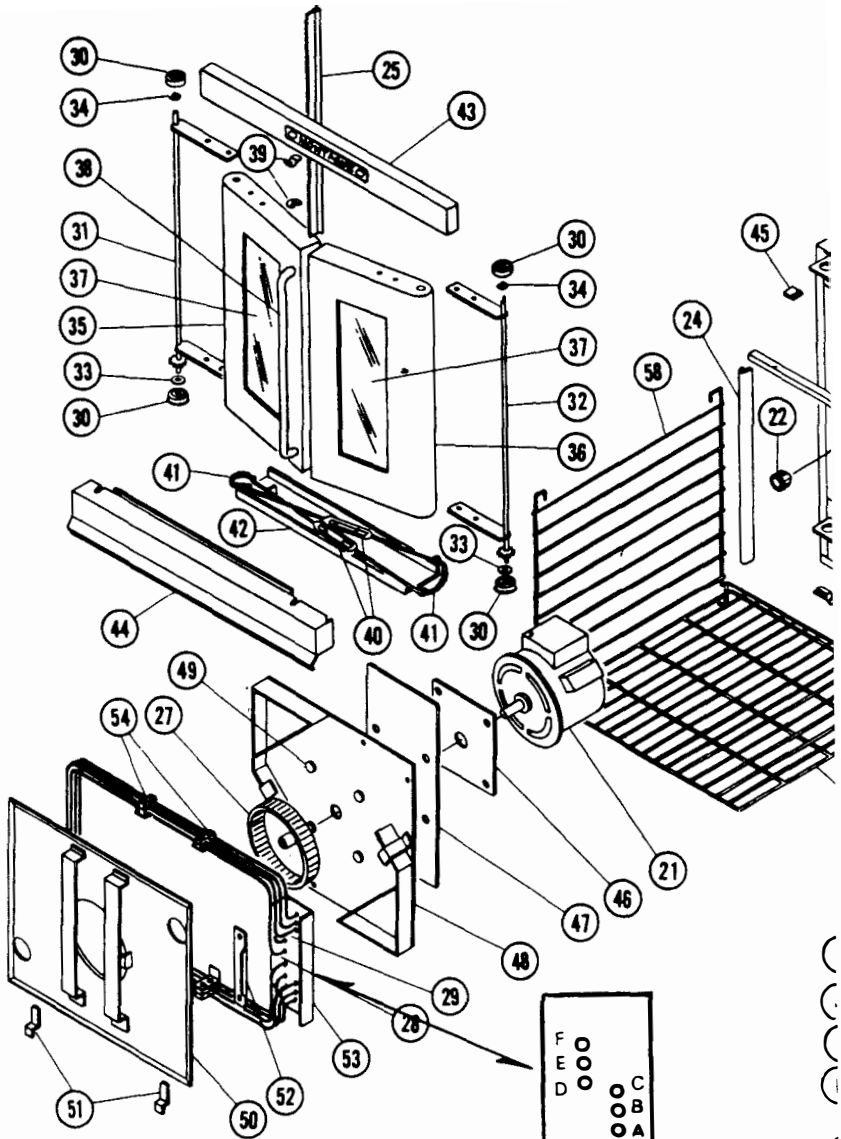

Change 11
 No. 104-0 4/77

REAR VIEW

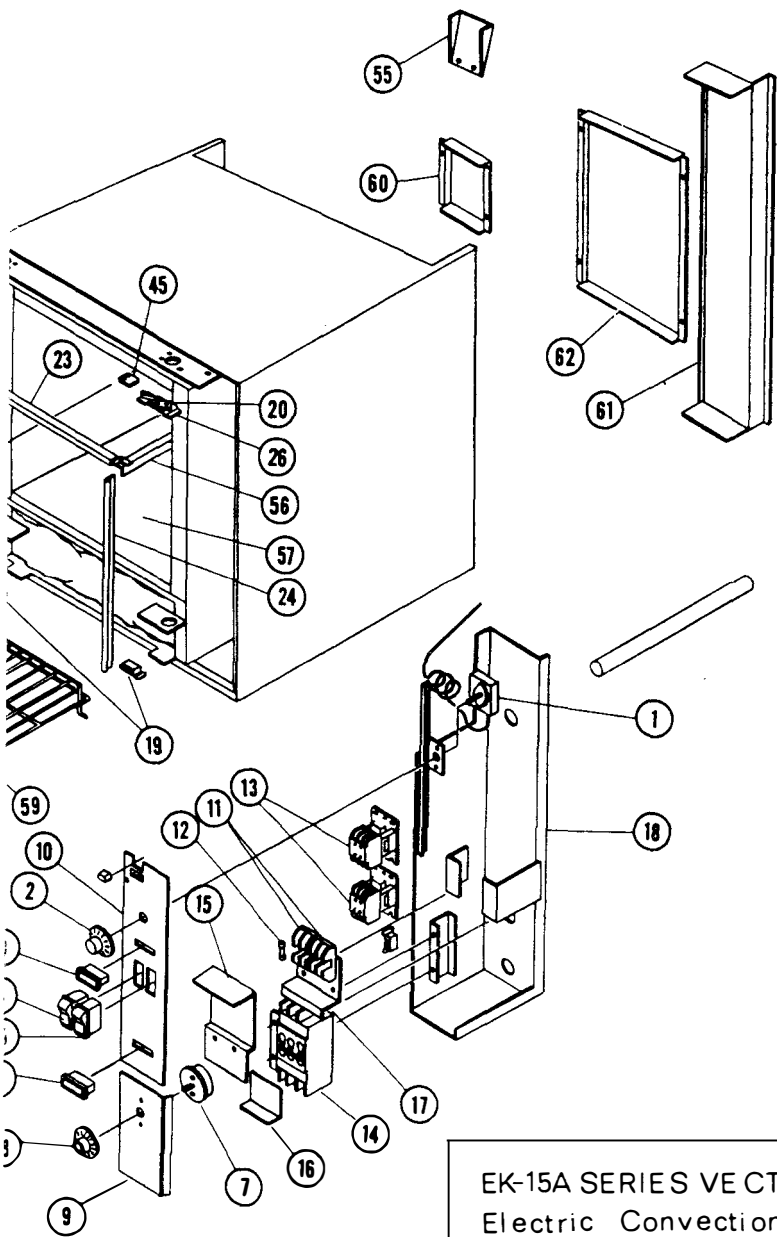

EK-15A SERIES VECTAIRE
Electric Convection Oven

EK - 15A SERIES VECTAIRE ELECTRIC CONVECTION OVEN			QUANTITY					
			1 PHASE		3 PHASE			
			208V	220V 240V	208V	220V 240V	480V	
Item No.	Part No.	Description						
1	EV-1A	Thermostat	1	1	1	1	1	1
2	EV-1-1	Thermostat Dial	1	1	1	1	1	1
3	EV-16-1	Indicator Light - "On - Ready"	1	1	1	1	1	1
4	EV-17-3	Switch, Light	1	1	1	1	1	1
5	EV-17-4	Switch, Fan	1	1	1	1	1	1
6	EV-16-2	Indicator Light - "Power	1	1	1	1	1	1
7	V-24A	Timer, Manual	1	1	1	1	1	1
8	V-24A-1	Timer Dial	1	1	1	1	1	1
9		Panel, Hinged	1	1	1	1	1	1
10		Panel, Control	1	1	1	1	1	1
11	EV-2	Fuse Block	2	2	2	2	2	1
12	EV-2-1	Fuse; Light (5Amp.)	2	2	2	2	2	0
	EV-2-2	Fuse; Motor (15 Amp.)	2	2	2	2	2	2
13	EV-4-2	Contactor; 2 Pole, 1Ø	2	2	0	0	0	0
	EV-4-1	Contactor; 3 Pole, 3Ø	0	0	2	2	2	1
14	EV-6-2	Circuit Breaker; 2 Pole, 1Ø (80 Amp.)	1	1	0	0	0	0
	EV-6-1	Circuit Breaker; 3 Pole, 3Ø (50 Amp.)	0	0	1	1	1	0
	EV-6-5	Circuit Breaker; 3 Pole, 3Ø (40 Amp.)	0	0	0	0	0	1
15		Cover, Fuse	1	1	1	1	1	1
16		Cover, Circuit Breaker	1	1	1	1	1	1
17		Bracket, Fuse Holder	1	1	1	1	1	1
18		Electrical Enclosure	1	1	1	1	1	1
19		Magnetic Catch	3	3	3	3	3	3
20	EV-118	Switch, Door	1	1	1	1	1	1
21	V-23-1	Motor; 208/240V, 1Ø, 60HZ	1	1	1	1	1	1
22	V-19B	Light Socket	2	2	2	2	2	2
23	V-131	Seal; Upper Door, S/S	1	1	1	1	1	1
24	V-131-1	Seal; Side Door, S/S	2	2	2	2	2	2
25	V-131-M	Seal; Center Door, S/S	1	1	1	1	1	1
26		Bracket; Door Switch	1	1	1	1	1	1
27	V-26	Fan w/Set Screw	1	1	1	1	1	1
*28	EV-14-1A	Elements, Inner Set (A, B & C) 208V	1	0	1	0	0	0
		Elements, Inner Set (A, B & C) 220-240V	0	1	0	1	1	1
*29	EV-14-2A	Elements, Outer Set (D, E & F) 208V	1	0	1	0	0	0
		Elements, Outer Set (D, E & F) 220-240V	0	1		1	1	1
30	V-133	Bearing; Oven Door	4	4	4	4	4	4
31	V-127-3	Trunnion; Left	1	1	1	1	1	1
32	V-128-3	Trunnion; Right	1	1	1	1	1	1
33		Spacer; Door	2	2	2	2	2	2
34		Keeper; Door Trunnion	2	2	2	2	2	2
35		Door; Oven Handle Side S/S	1	1	1	1	1	1
36		Door; Oven S/S	1	1	1	1	1	1
37	V-27/28-2	Window	2	2	2	2	2	2
38	V-29	Handle, Oven Door	1	1	1	1	1	1
39	V-130-1	Spring Clip-Oven Door	2	2	2	2	2	2
40	V-127	Turn Buckle w/Rods	2	2	2	2	2	2
41	V-128	Chain; Oven Door	2	2	2	2	2	2
42		Guard, Door	1	1	1	1	1	1
43		Panel; Upper S/S	1	1	1	1	1	1
44		Panel; Removable	1	1	1	1	1	1

Macaroni and Cheese	350		30 min
Beef Pot Pies	400		30-35 min.
Turkey Pot Pies	400		30-35 min.
Stuffed Peppers	350		15-20 min.
Melted Cheese Sandwiches	400		8 min.
Hamburger Patties	400	5 per lb.	8-10 min.
Fish Stix	335		16-18 min.

Hamburger in buns 400 13 min.
 Frozen & wrapped (Best when buns buttered & meat cooked)

Hot Dogs in buns 400 200 10 min.
 Frozen (Best when buns buttered & weiners raw)

MEAT, POULTRY, FISH

Spaghetti & Meatballs	400	2" Deep	45 min.
Veal (boned rolled)	275-300	15 lb.	3 hrs.
Veal (boned rolled-B)	300	15 lb.	3 hrs. 10 min.
Prime rib	250	6-20 lb.	1-1/2 hrs.
Prime rib (B) std.	250	4-20 lb.	2-3/4 hrs.
Top sirloin	225	11 lb.	
Steamship rd. qtr.	275	80 lb.	2-3/4 hrs.
Pot Roast	250		4-3/4 hrs.
Rollod roast (B)	275	12-15 lb.	2-1/2 hrs.
Top Round	200		3 hrs.
Cafeteria Rd.	225	45 lb.	9 hrs.
Roast (boned rolled)	275-300	20 lb.	3 hrs.
Steaks, N.Y.	450	12 oz.	7 min.
Steaks, Salisbury	300	8 oz.	20 min.
Baked Stuffed Pork Chops	375		25-30 min.
Boned Veal Roast	300	15 lbs	3 hr., 10 min.
Lamb Chops	400	Small Loim	6 min.

Lobster 500 9-12 min.
 Stuffed 400 1-1/2 lb. 6-7 min.
 Tails 450 8 oz. 7 min.

Baked Stuffed Shrimp 400 6-7 min.
 Halibut Steaks(Frozen) 350 5 oz. 20 min.

Chicken breast with wild rice 375 164 25 min.
 Chicken breast 225 35 min.
 Chicken, whole, fried 350 40 min.
 Chicken thighs 350 40 min.

Turkev 325 18 lb. 45 min.

Turkey, rolled 310 18 lb. 3 hrs. 45 min.

Idaho Potatoes 400 120 count 50 min.

OVEN STEAMED FRESH

VEGETABLES

Cabbage (wedges)	400	3 heads(16 wedges each)	40 min.
Carrots (sliced)	325	1-1/2 Gal.	75 min.
Celery (sliced)	325	1-1/2 Gal.	70 min.
Onions (sliced)	325	1-1/2 Gal.	60 min.

OVEN STEAMED FROZEN

VEGETABLES

Beans (Green)	400	5#	24 min.
Broccoli (Spears)	400	5#	20 min.
Cauliflower	400	5#	30 min.
Corn	400	5#	20 min.
Limas (Baby)	400	5#	40 min.
Peas	400	5#	15 min.

BAKING DIFFICULTIES & PROBABLE CAUSES

Good baking is a delicate operation and many operation factors enter into it.

Pans which warp or buckle under heat always result in poor bakes. Pans with highly-polished reflecting surfaces generally cause light colored bottoms and sides. Muffin tin cups should all rest on a flat surface; otherwise, light or underdone bottoms will be the result. Pie tins that are pocked or warped will give undesirable doneness.

Overproofing, working of doughs in too high room temperature, overworking pastry doughs, absence of or improper scaling and cutting and uneven loading of pans are sure ways of getting uneven baking.

"Hit or miss" recipe mixing; guess work in the matter of quality and quantity of ingredients frequently results in poor bakes.

The following are some baking problems and their probable causes:

Goods Pulled to Rear of Oven

1. Oven not level. Pitched to rear causes dough to run to rear.
2. Pans too full. Excess will pull over back toward fan.
3. Batter has too high a percentage of liquid.

Uneven Bakes

1. Insufficient heat input.
2. Warped pans.
3. Warped oven racks.
4. Uneven loading of pan or pans.
5. Fan off.
6. Oven not level causing dough to run to side or rear of pan.

Spotty Pie Bottoms

1. Overworked pastry.

Spotty Bread

1. Overworked dough.

Burned Goods, Cripples

1. Incorrect temperature.
2. Thermostat out of calibration.
3. Left in too long.
4. Improper scaling.

Dried Out Goods

1. Too low temperature.
2. In oven too long.
3. Improper mix.

Alternately Good and Poor Results

1. Fan off and on.
2. Improper scaling and control of ingredients.

Tops Dark, Center Not Done

1. Too High Temperature.

Side Burning

1. Oven not level.
2. Uneven loading.

Lack of Uniformity, same pan

1. Uneven loading in pan. (See uneven bakes)
2. Faulty pans.

Lack of Spring

1. Overproofing
2. Incorrect temperature.

Cracked Cakes

1. Too high temperature.
2. Too fast cooling.

Underdone Pie Bottoms (Advisable to bake on cookie sheet)

1. Pastry too rich.
2. Pastry too thick.
3. Warped pie tins (When used on cookie sheet)

Heavily Colored Pie Rims

1. Air bubbles enclosed in pastry when crimped.

Uneven Baked Cookies

1. Not scaled properly.
2. Pans warped.

4. MAINTENANCE

GENERAL CLEANING

The complete oven should be given a periodic general cleaning. Lint and grease suspended in the air tend to collect in passages. Therefore, all air passages and openings should be periodically cleaned to prevent clogging.

CLEANING TIPS:

EXTERIOR: Wash painted surfaces with mild soap and water, drying with clean cloth. For S/S surfaces, see Stainless Steel section.

INTERIOR:

1. STANDARD OVEN

- *Wipe up spillovers while oven is hot. Wait until oven is cool for complete cleaning.
- *Racks and rack guides may be removed for cleaning.
- *A mild abrasive nylon cleaning pad may be used for stubborn spillovers or stains.
- *Do not allow spray-type oven cleaners to come in contact with capillary tubes.
- *After cleaning interior, rinse well with 1/4 cup vinegar to 1 qt. water solution to neutralize any caustic residue of cleaning compound. Wipe dry.

2. CONTINUOUS CLEAN OVEN

- *Cleaning action of catalytic porcelain lining occurs whenever heat is applied -- even during baking or roasting. The higher the temperature, the faster the cleaning action.
- *Avoid excessive soil by placing foods, such as casserole dishes and fruit pies, on bun pans to bake. If spillage does occur, wipe up immediately.
- *Wipe off residual ash from normal cleaning action with damp cloth when oven has cooled.
- *To treat baked-on soil build-up or stubborn stains, apply household ammonia with oven at room temperature (never use when oven is warm) and rub gently with nylon brush. Remove loosened particles with damp cloth.

- *Never use abrasive materials, cleansing powders, harsh liquids, or caustic sprays. They can damage the special interior surface and prevent cleaning action.
- *Clean oven door lining as required and wipe inside of door with household ammonia to aid self-cleaning.

NOTE:

To clean behind baffle: remove 2 screws and pull forward. It is advisable to occasionally remove fan from shaft as concave fan blades tend to collect grease thus lowering efficiency of fan circulation.

CLEANING STAINLESS STEEL

Stainless Steel is remarkably easy to clean. You can quickly remove fingerprints, dust and ordinary stains simply by rubbing the stainless with a clean damp cloth.

And it's no trick at all to remove such stubborn, sticky materials as burnt-on grease, dried food particles and coffee stains, if you follow the suggestions offered below.

With reasonably good care, your stainless steel will stay new-looking for years to come. Under ordinary conditions, the secret of keeping your stainless surfaces bright as new is simple: light but frequent cleaning, usually with no more than a damp cloth. Then dry with a soft cloth.

For slightly more difficult applications, you may use any of the following: (1) ammonia in water, (2) detergent in water, or (3) special solvents, such as alcohol, baking soda, vinegar or turpentine. Follow these with a thorough washing with detergent and hot water, then rinse and dry with a soft, clean cloth. For a high polish, apply a mild abrasive cleanser and rub in the direction of the polish lines to preserve the original finish.

Foods that burn and stick on other metals can discolor stainless, too. But with a stainless steel unit you can remove discolorations by applying a mildly abrasive cleanser such as Bon Ami. To soften an extremely heavy layer of burnt-on grease, cover the

layer with an ammonia-soaked cloth for 10 to 15 minutes. You might also use a plastic or stainless steel sponge. Then wash, rinse and dry as usual.

You can eliminate fingerprints on highly polished surfaces by applying a commercial glass cleaner or automobile wax. After you remove the excess cleaner with a soft cloth, a thin protective film remains. If some fingerprints do appear later, they can be easily wiped away with a cloth containing some of the cleaner.

Precautions:

1. Strong bleaches tend to corrode many materials and should not come in contact with stainless steel sinks or utensils longer than 30 minutes. When these chemicals are used, the stainless should be rinsed thoroughly.
2. Tincture of iodine or iron should not remain in contact with stainless surfaces. These solutions, which cause stainless to discolor, should be rinsed off immediately after contact.
3. Some foods, such as mustard, mayonnaise, lemon juice, vinegar, salt or dressings containing these, will attack and corrode stainless. You should never store them in stainless containers.
4. Ordinary steel wool should be used sparingly to clean stainless; particles may lodge in the surface and rust. Allowing the wool to rest on a stainless surface may cause a rusty appearance. For difficult cleaning jobs such as removing burned-on foods, stainless steel "sponges" or pads are recommended. When cleaning a highly polished, mirror finish with a metal pad, be especially careful that it does not scratch the finish.
5. Gritty, hard abrasives will mar a stainless finish and are not recommended.
6. Sharp knives or choppers usually have hard carbon steel edges and will leave their mark on stainless surfaces.

With only a little care, your stainless steel equipment and utensils will remain clean and bright for years to come. Stainless is a hard, rust-resisting metal that adds beauty and lustre to countless household products.

5. SERVICE

DISCONNECT POWER BEFORE DOING ANY SERVICE WORK. EACH OVEN HAS SEPARATE ELECTRICAL SUPPLY CONNECTION.

Model EK-15A
Model EK-15R
Model 2EK-15RF

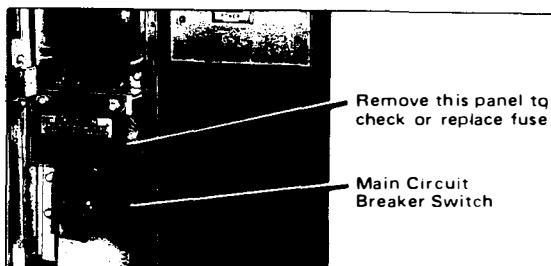

Fig 9

MAIN CIRCUIT BREAKER SWITCH (See Fig.9)

This switch is located behind the hinged timer panel. Open timer panel by grasping timer knob and gently pulling knob forward. To replace the switch:(1) Turn off the main source of electrical power to the oven(s). (2) Remove the panels above and below the circuit breaker switch by removing the hex head screws holding panels. (3) Remove line wires from the bottom of the switch. (4) Remove the load wires on top of the switch. (5) Remove the two hex head screws on the left side of the breaker. This will allow brackets and breaker to be removed (forward). (6) Remove the breaker from the bracket by taking out the 4 machine screws with nuts. To install new breaker switch reverse the above procedure. Replace the same incoming line wires in their respective positions. All load wires of the same color will go to the line (top) side of the same color. Replace the panels above and below the switch. Close the hinged timer panel and replace the pointer knob.

UPPER CONTROL PANEL (See Fig. 10)

To remove panel for service or replacement: First, turn off the circuit breaker switch. Ease dial forward and off the thermostat stem. Remove the two screws at top and bottom on left side of panel. The light and fan

switch, and indicator lights, are attached to the panel. Push the right side of panel gently toward the rear of the oven. At the same time, pull the left side of panel forward and swing slightly to the right, easing it out until switches have cleared the left side of the opening. Be careful not to damage any wires or terminal connections. Pull forward far enough to change switches or indicator lamps. The "ON" and "READY" indicator lamps press into place from the front of panel. The light and fan switches are removed by pinching in the spring clamps holding them in place.

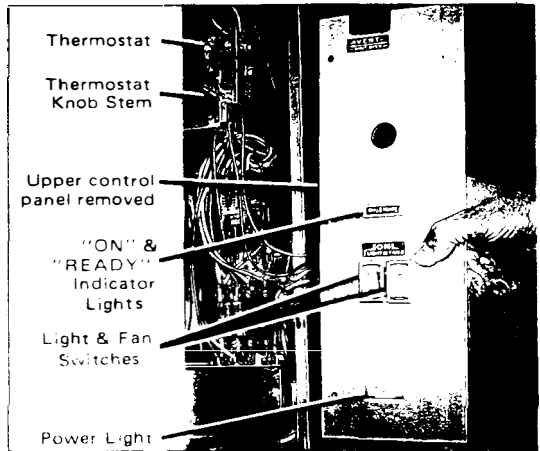

Fig 10

TO REMOVE OR REPLACE THERMOSTAT

Remove upper control panel (See instructions above). From inside of oven, remove the capillary bulb from the guard which protects it. Guard is located in the top right hand side of the oven. Remove the two screws holding the thermostat to the bracket. Push back and down gently. Disconnect electrical wires, noting which wire is connected to which terminal. Carefully ease the capillary tube out of the oven through the small opening. To replace, reverse the above procedure. **IMPORTANT:** Do not bend or kink the capillary tube as it will damage the thermostat.

THERMOSTAT:

The thermostat is of snap-action, single-line, double-break design with silver contacts and heavy-duty terminals. The power element consists of a stainless steel diaphragm with a capillary tube and bulb filled with a liquid having a high coefficient of expansion, provides extreme sensitivity to temperature

fluctuations. Thus it will operate within very close temperature differential. Each thermostat is adjusted at the factory and calibrated on precision instruments to control temperatures accurately. Adjustment or recalibration is not needed unless the thermostat has been mishandled in transit, or changed or abused while in service.

TO CHECK CALIBRATION:

1. Use a potentiometer or a good grade thermometer to determine temperature.
2. Place the thermocouple of the test instrument or a good grade oven thermometer in the middle of the oven.
3. Turn the dial of the thermostat to a temperature setting of 350 degrees.
4. Allow enough time for temperature to stabilize or until several temperature readings are identical.

TO RECALIBRATE: (See Fig. 11)

1. Remove dial from shaft "B"
2. Turn screw "A" clockwise to decrease, and counter-clockwise to increase. One-quarter (1/4) turn of screw "A" equals 35 degrees F.

After a calibration is made, let the appliance operate until the temperature has stabilized, then recheck to determine whether or not the calibration has been corrected.

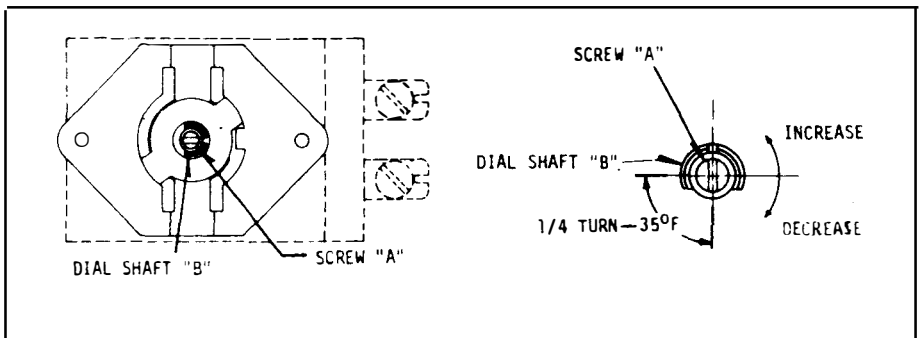
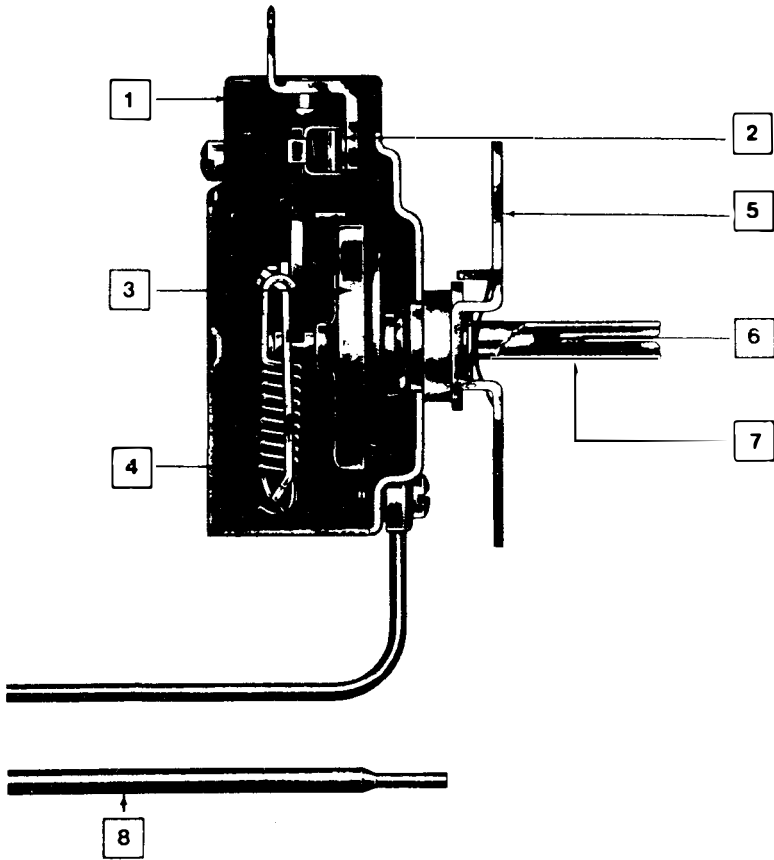

Fig. 11



- 1 — Model K—Bakelite Terminal Block
- 2 — Thermostatically operated contacts
- 3 — Stainless steel diaphragm
- 4 — Snap action mechanism
- 5 — Mounting bracket
- 6 — Front calibration set screw
- 7 — Dial shaft
- 8 — Sensing element

EV-1A THERMOSTAT

HIGH LIMIT CONTROL

This control is operated by a hydraulic element diaphragm which expands when the bulb temperature increases to the calibration temperature. The high limit control will actuate at a temperature of 550^oF or anytime leakage develops in the hydraulic element of the control. The sensing bulb is located inside the oven alongside the thermostat sensing bulb.

TO REMOVE TIMER, (60-MINUTE MECHANICAL) (See Fig.13)

This timer is located on the hinged panel at lower right hand of the front of the oven. TO REMOVE OR REPLACE: Open panel by grasping pointer knob and pulling forward. Pull pointer knob off of the timer stem. Remove the two screws-one above the stem, one below it. When replacing, make sure the part marked "TOP" is at the top of the panel.

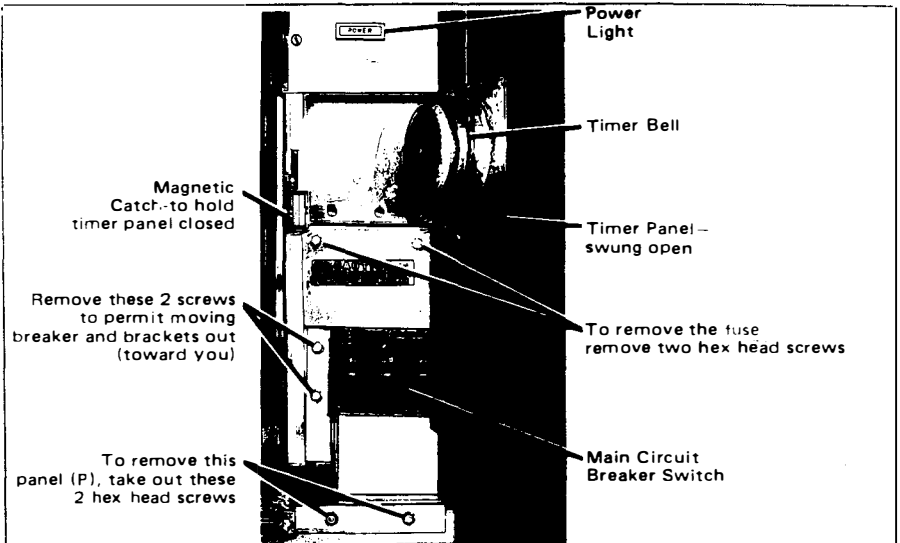

Fig.13

FUSES, LIGHT AND FAN

The fuses are located behind a panel directly above the circuit breaker. TO REPLACE: Turn off the circuit breaker switch. Remove the two screws holding the panel and lift panel out. For light circuit use 5 amp fuse (Type SC5). For motor circuit use a 15 amp fuse (Type SC15). Replace panel and secure with two screws. Turn circuit breaker switch back on.

LIGHTS, INTERIOR OF OVEN

To replace lamps inside the oven, first open the timer panel door and turn off the circuit breaker switch. Open the oven door. Remove racks. Remove the two hex head screws holding the fan baffle plate on back inside wall of oven. Lay this baffle plate on bottom of oven. Replace burned out lamps with 40 watt oven lamps. The lamps are wired in series, so if one burns out the other will not light. Once lamps are replaced, put fan baffle plate back in position, and secure with the two screws. If fan baffle plate is upside down the holes in the plate will not match up with the two lamps.

If any of the original wire as supplied with appliance must be replaced, it must be replaced with same type or its equivalent.

MODEL EK-15A EK-15R

208/240 VOLTS 60HZ 1 PH

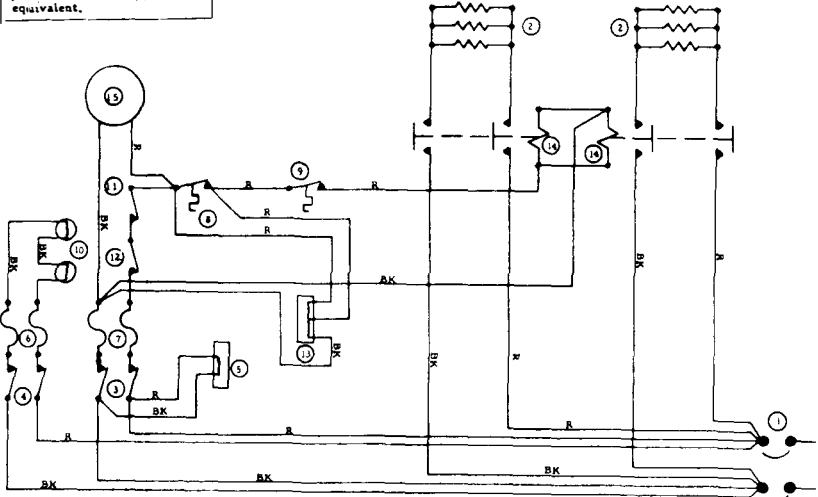

WIRING DIAGRAM
208-240V 60HZ 1PH

- | | | |
|-----------------------------|------------------------|--|
| 1. CIRCUIT BREAKER (2 POLE) | 6. FUSE, LIGHT - 5AMP | 11. SWITCH, DOOR ACTIVATED |
| 2. HEATING ELEMENTS | 7. FUSE, MOTOR - 15AMP | 12. SWITCH, CART ACTIVATED (EK-15R ONLY) |
| 3. SWITCH, FAN | 8. THERMOSTAT | 13. LIGHT, INDICATING - ON/READY |
| 4. SWITCH, LIGHT | 9. HIGH LIMIT SWITCH | 14. MAGNETIC CONTACTORS (2 POLE) |
| 5. LIGHT, INDICATOR - POWER | 10. LAMPHOLDERS | 15. MOTOR |

8/80

If any of the original wire as supplied with appliance must be replaced, it must be replaced with same type or its equivalent.

MODEL EK-15A - EK-15K

208/240 VOLTS 60HZ 3 PH

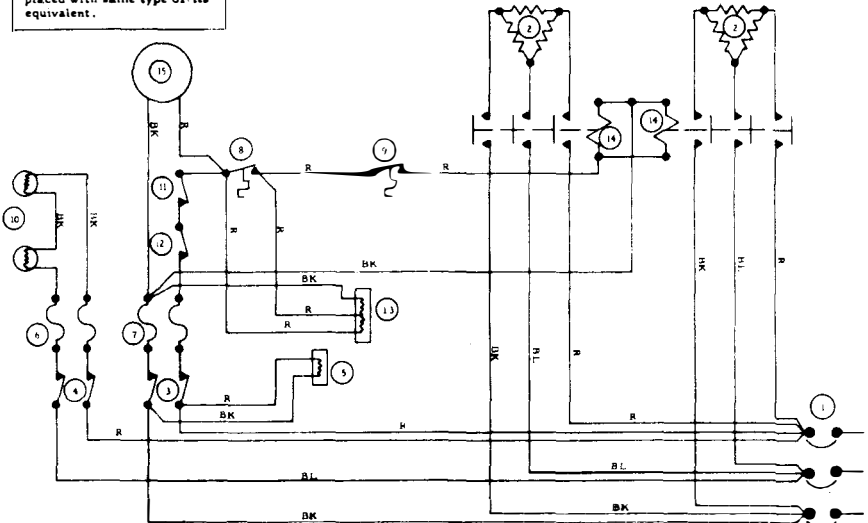

WIRING DIAGRAM
208-240V 60HZ 3PH

- | | | |
|------------------------------|-------------------------|--|
| 1. CIRCUIT BREAKER (3 POLE) | 6. FUSE, LIGHT - 5 AMP | 11. SWITCH, DOOR ACTIVATED |
| 2. HEATING ELEMENTS | 7. FUSE, MOTOR - 15 AMP | 12. SWITCH, CART ACTIVATED (EK-15R ONLY) |
| 3. SWITCH, FAN | 8. THERMOSTAT | 13. LIGHT, INDICATING - ON/READY |
| 4. SWITCH, LIGHT | 9. HIGH LIMIT SWITCH | 14. MAGNETIC CONTACTOR (3 POLE) |
| 5. LIGHT, INDICATING - POWER | 10. LAMPHOLDERS | 15. MOTOR |

8/80

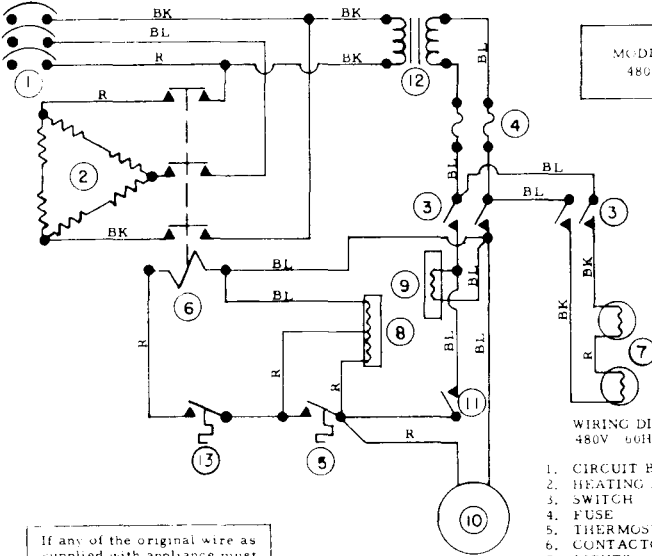

MODEL EK-15A - EK-15R
480 VOLT 60HZ 3PH

WIRING DIAGRAM
480V 60HZ 3PH

If any of the original wire as supplied with appliance must be replaced, it must be replaced with same type or its equivalent.

1. CIRCUIT BKR.
2. HEATING ELEMENTS
3. SWITCH
4. FUSE
5. THERMOSTAT
6. CONTACTOR
7. LIGHTS
8. INDICATOR LIGHT - ON/READY
9. INDICATOR LIGHT - POWER
10. MOTOR
11. DOOR SWITCH
12. TRANSFORMER
13. HIGH LIMIT SWITCH

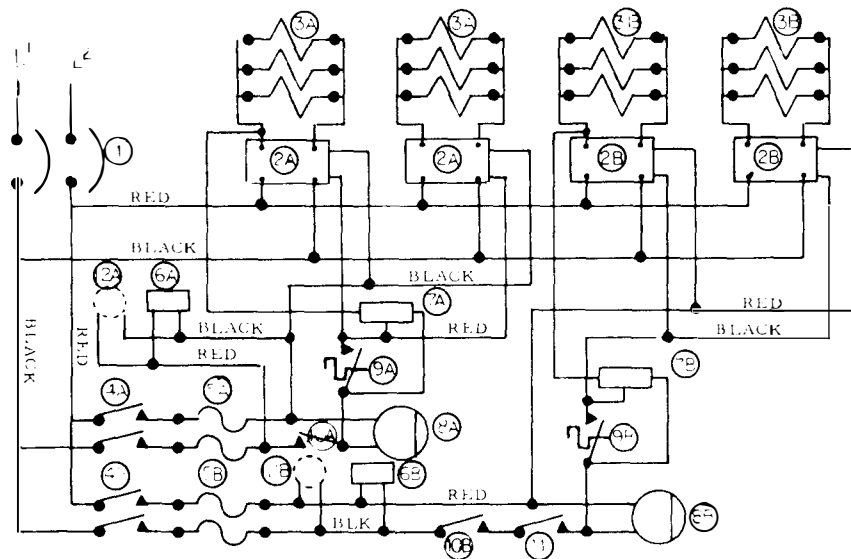

WIRING DIAGRAM E-2 1 PH.

1. Circuit Breaker 2-pole
2. Contactors 2-pole
3. Elements, Heating
4. Switch, DPST
5. Fuse, 15 Amp.
6. Light, Indicator, Power
7. Light, Indicator, On/Ready
8. Motor
9. Thermostat
10. Switch, Door SPST
11. Switch, Cart SPST
12. Timer, Electric (optional)

A. Upper Deck
B. Lower Deck

If any of the original wire as supplied with appliance must be replaced, it must be replaced with same type or its equivalent.

MODEL 2EK-15R F

Rev. 1 / 74

208/230 Volt 60 Cy. 1Ø

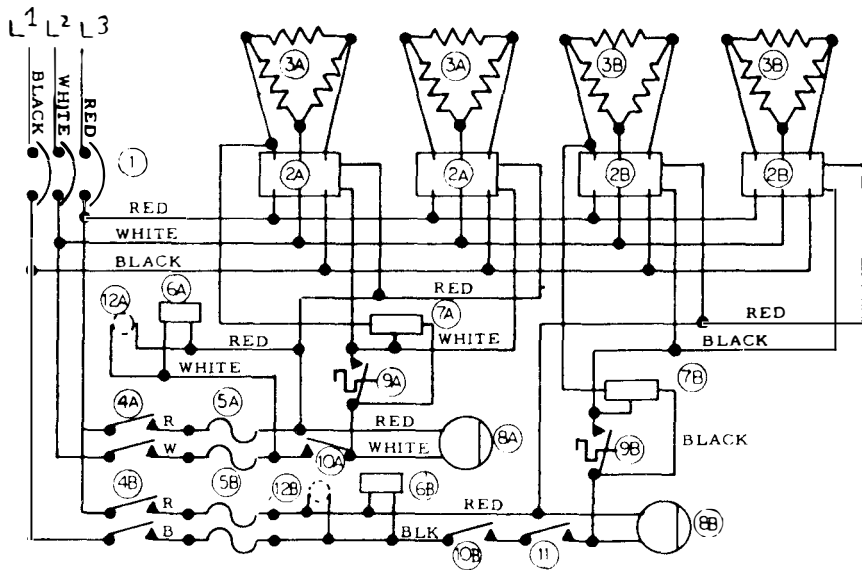

WIRING DIAGRAM E-2 3 PH.

1. Circuit Breaker 3-pole
2. Contactors 3-pole
3. Elements, Heating
4. Switch, DPST
5. Fuse, 15 Amp.
6. Light, Indicator, Power
7. Light, Indicator, On/Ready
8. Motor
9. Thermostat
10. Switch, Door SPST
11. Switch, Cart SPST
12. Timer, Electric (optional)

A. Upper deck
B. Lower deck

If any of the original wire as supplied with appliance must be replaced, it must be replaced with same type or its equivalent.

MODEL 2EK-15RF

Rev. 1 / 74

208/230Volt 60 Cy. 3Ø

IMPORTANT

Copy the following information
from the rating plate for your records:

Model No. _____

Serial No. _____

Change No. _____

**When ordering parts, to eliminate mistakes and facilitate
delivery, always give the above information.**



THE MONTAGUE COMPANY