

# INSTRUCTION MANUAL

**MONTAGUE**  
**GRIZZLY**



## Gas Fired Restaurant Ranges

**MODELS:**  
**G, GC, GM Series**  
**(25,000 BTU/HR Open Top Burners)**

**These instructions should be read thoroughly before attempting installation.  
Set up and installation should be performed by qualified installation personnel.**

**Keep area around appliances free and clear from combustibles.**

**PLEASE RETAIN THIS MANUAL  
FOR FUTURE REFERENCE.**



**THE MONTAGUE COMPANY**  
1830 Stearman Avenue P.O. BOX 4954  
HAYWARD, CA 94540-4954  
TEL: 510/785-8822 FAX: 510/785-3342

## CONTENTS

INSTALLATION .....	3
OPERATION .....	10

MAINTENANCE .....	12
SERVICE .....	15
RENEWAL PARTS .....	23

# IMPORTANT

### **WARNING:**

Improper installation, adjustment, alteration, service or maintenance can cause property damage, injury or death. Read the operating and maintenance instructions thoroughly before installing or servicing this equipment.

### **FOR YOUR SAFETY:**

Do not store or use gasoline or other flammable vapors and liquids in the vicinity of this or any other appliance.

**INSTRUCTIONS TO BE FOLLOWED IN THE EVENT THE USER SMELLS GAS MUST BE POSTED IN A PROMINENT LOCATION. THIS INFORMATION MAY BE OBTAINED BY CONSULTING THE LOCAL GAS SUPPLIER.**

## **SHIPPING DAMAGE CLAIM PROCEDURE**

For your protection, please note that equipment in this shipment was carefully inspected and packed by skilled personnel before leaving the factory. The transportation company assumes full responsibility for safe delivery upon acceptance of this shipment.

### **If shipment arrives damaged:**

1. **VISIBLE LOSS OR DAMAGE**—Be certain this is noted on freight bill or express receipt, and signed by person making delivery.
2. **FILE CLAIM FOR DAMAGES IMMEDIATELY**—Regardless of the extent of damage.
3. **CONCEALED LOSS OR DAMAGE**—If damage is unnoticed until merchandise is unpacked, notify transportation company or carrier immediately, and file “concealed damage” claim with them. This should be done within fifteen (15) days of date that delivery was made to you. Be sure to retain container for inspection.

*We cannot assume responsibility for damage incurred in transit. We will, however, be glad to furnish you with necessary documents to support your claim.*

## INSTALLATION

The Montague Grizzly gas oven ranges are manufactured for use with the type of gas indicated on the name plate.

The Montague Grizzly gas convection oven type ranges are produced with the best possible material and workmanship. PROPER INSTALLATION IS ESSENTIAL FOR SAFE AND EFFICIENT TROUBLE-FREE OPERATION.

**THE INSTALLATION INSTRUCTIONS CONTAINED HEREIN ARE FOR THE USE OF QUALIFIED INSTALLATION AND SERVICE PERSONNEL ONLY. INSTALLATION OR SERVICE BY OTHER THAN QUALIFIED PERSONNEL MAY RESULT IN DAMAGE TO THE OVEN AND/OR INJURY TO THE OPERATOR.**

Qualified installation personnel are individuals, a firm, corporation, or company which in person, or through a representative are engaged in, and are responsible for:

- A. The installation or replacement of gas piping or the connection, installation, repair, or servicing of equipment, who is experienced in such work, familiar with all precautions required, and has complied with all requirements of state or local authorities having jurisdiction. Reference: National Fuel Gas Code Z223.1, Section 1.4.
- B. The installation of electrical wiring from the electric meter, main control box, or service outlet to the electric appliance. qualified installation personnel must be experienced in such work, be familiar with all precautions required, and have complied with all requirements of state and local authorities having jurisdiction. Reference: National Electric Code, NFPA No. 70.

**READ CAREFULLY AND FOLLOW THESE INSTRUCTIONS**

THE RANGE(S) MUST BE INSTALLED IN ACCORDANCE WITH LOCAL CODES, OR IN THE ABSENCE OF LOCAL CODES, WITH THE NATIONAL FUEL GAS CODE, ANSI Z223.1, NATURAL GAS INSTALLATION CODE, CAN/CGA-B149.1, OR THE PROPANE INSTALLATION CODE, CAN/CGA-B149.2, AS APPLICABLE, INCLUDING:

1. The appliance and its individual shutoff valve must be disconnected from the gas supply piping system during any pressure testing of that system at test pressures in excess of 1/2 psig. (3.45 kPa)
2. The appliance must be isolated from the gas supply piping system by closing its individual manual shutoff valve during any pressure testing of the gas supply piping system at test pressure equal to or less than 1/2 psig. (3.45 kPa)

## INSTALLATION

**PROVISIONS MUST BE MADE FOR ADEQUATE AIR SUPPLY TO THE UNIT.**

**THE UNIT, WHEN INSTALLED, MUST BE ELECTRICALLY GROUNDED IN ACCORDANCE WITH LOCAL CODES, OR IN ABSENCE OF LOCAL CODES, WITH THE NATIONAL ELECTRICAL CODE, ANSI/NFPA 70, OR THE CANADIAN ELECTRICAL CODE, CSA C22.2, AS APPLICABLE.**

### Ventilating Hood

The range(s) must be installed under a properly designed ventilating hood. The hood should extend at least 6" beyond all sides of the unit. The hood should be connected to an adequate mechanical exhaust system.

Information on the construction and installation of ventilating hoods may be obtained from the 'Standard for the Installation of Equipment for the Removal of Smoke and Grease Laden Vapors from Commercial Cooking Equipment', NFPA 96, available from the National Fire Protection Association, Batterymarch Park, Quincy, MA 02269.

It is also necessary that sufficient room air ingress be allowed to compensate for the amount of air removed by the ventilating system. Otherwise, a subnormal atmospheric pressure will occur which may interfere with burner performance or may extinguish the pilot flame. In case of unsatisfactory range performance, check with the exhaust fan in the "OFF" position.

### Clearances

Adequate clearance must be provided at the side, back, and in the aisle to allow the doors to open sufficiently to permit the removal of the racks and for serviceability. Adequate clearance for air openings into the combustion chamber must be provided.

#### CLEARANCES

##### COMBUSTIBLE CONSTRUCTION

##### NONCOMBUSTIBLE CONSTRUCTION

Back

2" (5.1cm)

2" (5.1cm)

Left & Right Side

11"(27.9cm)

2" (5.1cm)

**6" (15.2cm) HIGH LEGS: SUITABLE FOR INSTALLATION ON COMBUSTIBLE FLOORS.  
WITHOUT LEGS: FOR USE ONLY ON NONCOMBUSTIBLE FLOORS.**

#### CAUTION

**DO NOT OBSTRUCT THE FLOW OF COMBUSTION AND VENTILATION AIR. KEEP THE  
APPLIANCE AREA FREE AND CLEAR FROM COMBUSTIBLES**

## ASSEMBLY

**DO NOT LIFT RANGE BY THE FRONT RAIL.**

Uncrate range as near to final location as possible. Remove all shipping wire from burners and all packing material and accessories from oven interior.

**IF RANGE IS EQUIPPED WITH A FRYTOP SECTION, REMOVE WOOD SHIPPING STRIPS LOCATED BELOW THE GREASE TROUGH.**

Then assemble as follows:

Floor Mounted Range:

1. Screw the adjustable feet of the legs in all the way. Then tightly screw the complete leg assembly into mounting holes at each corner of the range. If the unit is intended for curb installation, no legs are provided. The curb must be noncombustible material.
2. Install door handle and secure with screws that are provided. See diagram for correct orientation.

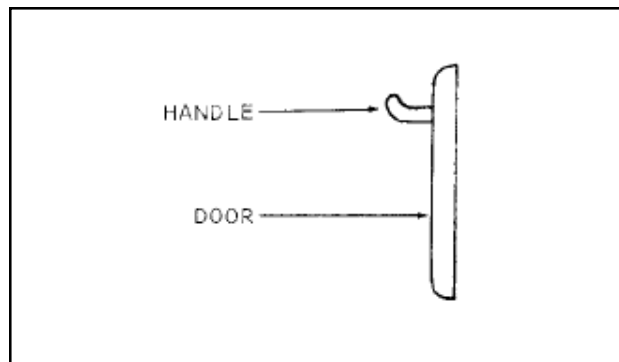

3. Lift high shelf above the range and slide channels into position. Secure to range back with screws that are provided.

## INSTALLATION

Cabinet or Skeleton Ranges:  
Follow above instructions.

Modular Ranges:  
Assemble modular base and set in place. Adjust feet as explained above.

Counter Ranges:  
Set unit in desired position and secure to counter using holes provided at rear and bracket at front.

All Ranges:

1. Install Open Top and Hot Top sections as shown in diagram below. Install burner bowls and grates on Open Top section.

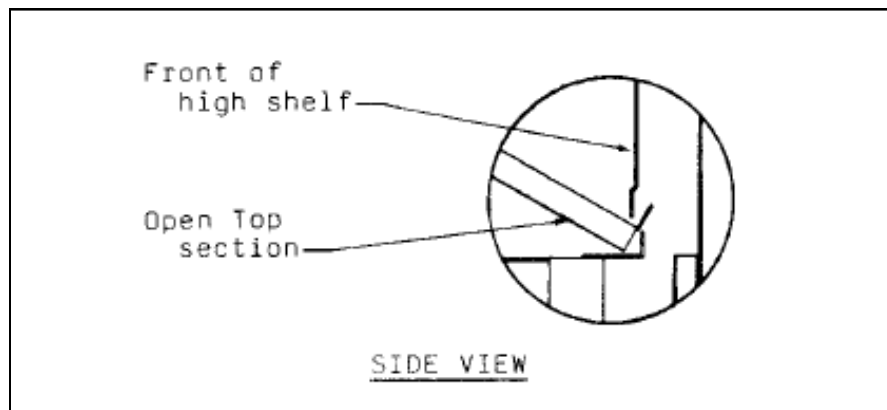

2. Install top burner valve handles, and thermostat knob(s). If top burner valve handles fit loose on valve shaft, spread slot on end of shaft slightly with screwdriver blade so that handle will fit snug.
3. When range is in permanent position, level unit by placing carpenter's level on oven bottom and level from front to back and side to side.

Adjust as follows:

FLOOR INSTALLATION ON LEGS: Adjust by turning the foot of the adjustable leg. Make sure the leg does not turn.

COUNTER OR CURB INSTALLATION: Level range from front to rear and side to side using a carpenter's level. Place shim under low side.

### Fry Top Ranges

Leveling bolts are at the rear of the range under the Fry Top plate. Adjust leveling bolts so that the plate is pitched to the front to provide for grease runoff. Be sure wooden strips have been removed from below the grease trough.

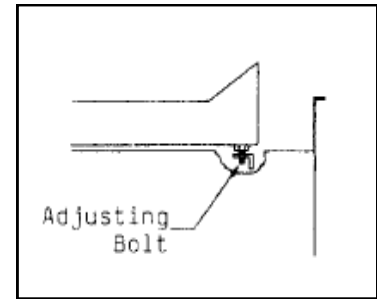

### GAS PRESSURE REGULATOR

**THIS RANGE IS DESIGNED FOR USE WITH A GAS PRESSURE REGULATOR. THE REGULATOR SUPPLIED WITH THIS UNIT MUST BE USED.**

**FOR NATURAL GAS:** This gas pressure regulator is factory adjusted for 6.0" W.C. manifold pressure. The rated inlet pressure to the regulator is 1/2 psig (3.45kPa).

**FOR PROPANE GAS:** This gas pressure regulator is factory adjusted for 10.0" W.C. manifold pressure. The rated inlet pressure to the regulator is 1/2 psig (3.45kPa).

**Unless otherwise specified, the range is equipped with fixed orifices for use with a manifold pressure of 6.0" water column for natural gas and 10.0" water column for propane gas.**

### GAS CONNECTION

Before connecting the range to the gas supply line, be sure that all new piping has been cleaned and purged to prevent any foreign matter from being carried into the controls by the gas. In some cases, filters or drops are recommended. A separate Gas Shut Off Valve must be installed upstream from the gas pressure regulator adjacent to the range and be located in an accessible area.

It is important that adequately sized piping be run directly to the point of connection at the range, with as few elbows and tees as possible. Consult local gas company for proper piping size and gas pressure.

## INSTALLATION

**PIPE JOINT COMPOUND OR THREAD SEALANT THAT IS USED SHOULD BE RESISTANT TO ACTION OF LIQUEFIED PETROLEUM GASES.**

Install the gas pressure regulator with gas flowing as indicated by the arrow on the regulator. Use pipe compound or thread sealant and carefully thread regulator to pipe so that there is no cross-threading, etc, which could cause leakage.

Apply wrench only to the flat areas around the pipe tapping at the end being threaded to the pipe to avoid possible damage to the regulator body which could result in leakage.

Connect the gas supply line from the Service Gas Shut Off valve to the inlet side of the gas pressure regulators using 3/4" pipe. If flexible or semi-flexible connectors are used, an AGA listed flexible connector with an I.D. equal to 3/4" pipe must be used. **DO NOT USE A DOMESTIC APPLIANCE TYPE GAS FLEXIBLE CONNECTOR.** Avoid kinks or sharp bends that could restrict gas flow.

Turn Gas Shut Off Valve "ON" and immediately check carefully for gas leaks. Do this before attempting to operate the range.

**TEST ALL PIPE JOINTS FOR LEAKS BEFORE OPERATING RANGE. THIS INCLUDES ALL GAS CONNECTIONS THAT MAY HAVE LOOSENED DURING SHIPMENT. USE A RICH SOAP SOLUTION (OR OTHER ACCEPTED LEAK TESTER) AROUND ALL PIPE CONNECTIONS AND ALL OTHER JOINTS. DO NOT USE AN OPEN FLAME. ABSOLUTELY NO LEAKAGE SHOULD OCCUR, OTHERWISE THERE IS A DANGER OF FIRE OR EXPLOSION DEPENDING UPON CONDITIONS. NEVER USE IF LEAKAGE IS DETECTED.**

**PILOT ADJUSTMENT—TOP BURNERS**

OVEN TOP: The front and rear pilots are controlled by one valve. To adjust pilot, turn adjusting screw counterclockwise to increase or clockwise to decrease pilot flame. Adjust flame to a point where only a trace of yellow tip remains.

FRY TOP and HOT TOP: Each pilot is controlled by a pilot valve. Turn adjusting screw until pilot flame is 1/2" high.

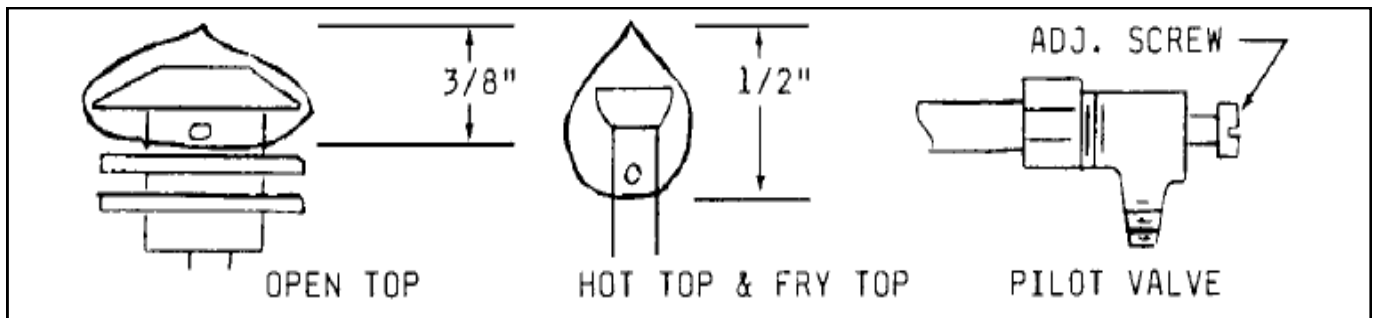
**BURNER ADJUSTMENT**

The efficiency of the range depends on a delicate balance between the supply of air and the volume of gas so that complete combustion is achieved. Whenever this balance is disturbed, poor operating characteristics occur.

The air supply is controlled by an air shutter on the front of the burner. The air shutter openings should be increased until the flame on the burner begins to "lift". The air shutter should then be closed slightly and locked in place. A yellow streaming flame indicated insufficient air. This condition can be corrected by increasing the air shutter opening.

**FRY TOP AND OVEN THERMOSTATS**

The by-pass (minimum burner flame) has been adjusted at the factory and should require no further adjustment.

**THE BY-PASS FLAME MUST BE RECHECKED WHEN PERFORMING CHECKOUT OF RANGE PRIOR TO PLACING EQUIPMENT IN SERVICE. THE BY-PASS MUST BE SET CAREFULLY AND ACCURATELY. REFER TO SERVICE SECTION OF THIS MANUAL FOR PROPER PROCEDURE.**

## OPERATION

**OPERATING INFORMATION FOR THE RANGE HAS BEEN PREPARED FOR USE BY QUALIFIED AND/OR PROFESSIONAL OPERATING PERSONNEL.**

### CAUTION

**DO NOT OBSTRUCT THE FLOW OF COMBUSTION AND VENTILATION AIR. KEEP THE APPLIANCE AREA FREE AND CLEAR FROM COMBUSTIBLES.**

**IN THE EVENT A GAS ODOR IS DETECTED, SHUT DOWN UNITS AT MAIN SHUT OFF VALVE AND CONTACT THE LOCAL GAS COMPANY OR GAS SUPPLIER FOR SERVICE.**

## GAS CONTROLS

Top Burners— Open Top, Hot Top and Manual Fry Top

Check that pilots are burning. Then rotate valve handles counterclockwise to full on, burner will ignite automatically. Adjust flame height as desired. To shut down, rotate valve handle clockwise to “OFF” position.

Fry Top— Thermostat Controlled

Check that the pilot(s) are burning. Then push thermostat dial inward and rotate dial counterclockwise to maximum thermostat setting, burner(s) will ignite automatically. After ignition, turn thermostat dial to desired setting. To shut down, rotate thermostat dial clockwise to “OFF” position.

## OVEN

### A. Lighting

Turn thermostat knob to “OFF” position and wait five (5) minutes.

1. Remove burner compartment cover and open pilot access door.
2. Locate the Piezo Igniter in front of the pilot access door.
3. Press and hold red button in (Safety Pilot Valve) and repeatedly depress the button on the Piezo Igniter until the pilot burner ignites.
4. After pilot burner ignites, continue to hold red button depressed for 30 to 45 seconds or until pilot remain burning when button is released. If pilot goes out, repeat process.
5. If the pilot burner is unable to be lit with the Piezo Igniter, apply a lighted match to the pilot burner.
6. Close pilot access door and replace burner panel.

## OPERATION

7. Push thermostat dial inward and rotate dial counterclockwise to desired temperature setting.
8. IN THE EVENT OF PILOT FAILURE, ROTATE THERMOSTAT DIAL CLOCKWISE TO “OFF” POSITION AND WAIT FIVE (5) MINUTES FOR UNBURNED GAS TO ESCAPE FROM RANGE.

### **B. Shut Down**

Rotate thermostat dial clockwise to “OFF” position.

### **Oven Operation**

1. Turn thermostat dial to desired temperature.
2. Limit preheat time to 10-20 minutes.
3. Place food in oven. Make sure pans do not touch each other, or the oven walls.
4. Do not cover racks with aluminum foil.
5. Load and unload quickly. Avoid frequent opening of doors.
6. Turn off when not in use.

### **SUGGESTIONS**

- There is no need to preheat an Open Top burner. Use full flame to start foods cooking quickly; reduce flame to simmer foods. Regulate the burner so that flame tips just touch the bottom of the utensil. Use lids on pots to keep heat in. Turn burner off when not in use.
- Preheat Fry Top 10-15 minutes prior to use. Usually, a medium to low flame is adequate for light frying. If Fry Top has a thermostat, use it to avoid wasting gas and for best results. During slack periods, turn the burner down.

## MAINTENANCE

### Care and Cleaning

The complete oven should be given a periodic general cleaning. Lint and grease suspended in the air tend to collect in air passages. Therefore, all flueways, air passages and openings, burner ports, primary air openings, etc., should be periodically cleaned to prevent clogging.

### Exterior

PAINTED SURFACE: Allow equipment to cool after use and wash with a mild detergent or soap solution. Dry thoroughly with a clean cloth.

STAINLESS STEEL: To remove normal dirt, grease, or product residue from stainless steel, use ordinary soap and water (with or without detergent) applied with a sponge or cloth. Dry thoroughly with a clean cloth.

To remove grease and food splatter, or condensed vapors that have baked on the equipment, apply cleanser to a damp cloth or sponge and rub cleanser on the metal in the direction of the polish lines of metal. Rubbing cleanser as gently as possible in the direction of the polished lines will not mar the finish of the stainless steel. NEVER RUB WITH A CIRCULAR MOTION. Soil and burnt deposits which do not respond to the above procedures can usually be removed by rubbing the surface with SCOTCH-BRITE scouring pads or STAINLESS scouring pads. DO NOT USE ORDINARY STEEL WOOL as any particles left on the surface will rust and further spoil the appearance of the finish. NEVER USE A WIRE BRUSH, STEEL SCOURING PADS (EXCEPT STAINLESS), SCRAPER, FILE, OR OTHER STEEL TOOLS. Surfaces which are marred collect dirt more rapidly and become more difficult to clean. Marring also increases the possibility of corrosion attacking the surface.

TO REMOVE HEAT TINT: Darkened areas sometimes appear on stainless steel surfaces where the area has been subjected to high heat. These darkened areas are caused by thickening of the protective surface of the stainless steel and are not harmful. Heat tint can normally be removed by the foregoing, but tint which does not respond to this procedure calls for a vigorous scouring in the direction of the polish lines, using SCOTCH-BRITE scouring pads or a STAINLESS scouring pad in combination with a powdered cleanser. Heat tint action may be lessened by not applying or by reducing heat to equipment during slack periods.

### OPEN TOP SECTION

**DAILY:** After grates and burner bowls are cooked, soak in solution of sal soda or other grease solvent. Thoroughly wash open top section with a damp cloth using a mild detergent soap. Rinse with clean, damp cloth and dry thoroughly. Remove and clean drip pan(s) under burners.

**WEEKLY:** Brush burner head with a stiff wire brush and clean clogged ports with a stiff wire or ice pick.

Excessive grease build up may be removed from burners by soaking in a solution of washing soda or any good grease solvent. Dry burners by inverting on oven rack in a low temperature oven.

### FRY TOP SECTION

**DAILY:** Use flat edge of spatula or metal scraper to keep surface free of encrusted material during use, wipe frequently with heavy absorbent cloth. After griddle is cooled, polish with soft griddle stone or a good grade grill pad. **DO NOT SCRATCH.** The griddle may be washed with warm water and a cleanser. Water will not crack this griddle plate.

Empty grease container as often as necessary.

To oil the griddle, use hydrogenated shortening. Never use salad oils, margarine or butter, as these shortenings cannot withstand temperatures greater than 300 degrees Fahrenheit.

### HOT TOP SECTION

**DAILY:** Wipe top with heavy burlap or steel wool. Rub briskly until clean. The Hot Top plate may be washed with warm water and a cleanser. Water will not crack this Hot Top plate.

## **MAINTENANCE**

---

### **OVEN INTERIOR**

#### **Aluminized Steel — Top, Sides, and Back:**

**CAUTION!**

**Do not use wire brushes, steel wool, or caustic solutions such as spray type cleaners, ammonia, lye or soda ash. Damage to the aluminum coating will result. USE ONLY CLEANERS THAT ARE RECOMMENDED FOR USE ON ALUMINUM.**

#### **Porcelain Enamel— Bottom and Door Liner:**

Wipe up spillovers while oven is hot. Wait until oven is cool for complete cleaning. Spray type oven cleaners may be used. A mild abrasive nylon cleaning pad can be used for stubborn spillovers or stains. After cleaning, rinse well with 1/4 cup of vinegar to 1 quart water solution to neutralize any caustic residue of cleaning compound. Wipe dry.

**WHEN SERVICE IS NEEDED, CONTACT A LOCAL SERVICE COMPANY, DEALER, OR FACTORY TO PERFORM MECHANICAL MAINTENANCE AND REPAIRS. THESE INSTRUCTION ARE INTENDED FOR USE BY COMPETENT SERVICE PERSONNEL.**

**CAUTION!**  
**DISCONNECT POWER BEFORE DOING ANY SERVICE WORK. EACH SECTION HAS SEPERATE ELECTRICAL SUPPLY CONNECTIONS. TURN OFF GAS SUPPLY WHEN SERVICING GAS CONTROL SYSTEM.**

**SAFETY PILOT VALVE**

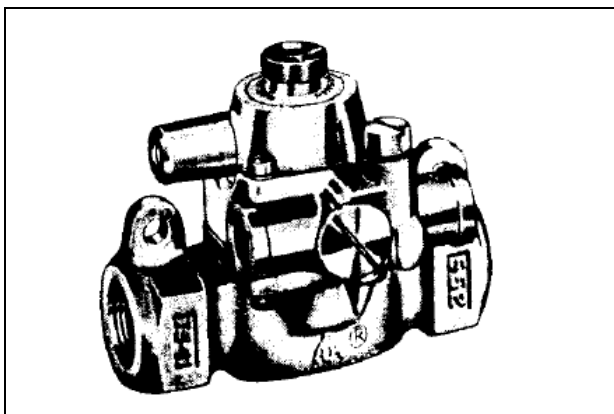

Model TS-11J IS AN AUTOMATIC 100% safety pilot which provides complete gas shut off in event of pilot failure. The safety valve is held closed by spring pressure. When red button is pushed by hand, gas flows to pilot. Pilot heats thermocouple creating a very small amount of electricity. This energizes a magnetic coil under red button and holds valve open, permitting gas to flow to main burner and pilot with out holding pressure on red button. In the event of pilot failure, the flow of electricity will stop, and spring will stop flow of gas to both pilot and oven burner.

**PIEZO IGNITER**

The PIEZO IGNITER creates an ignition spark at the pilot burner when the red button is depressed until it clicks. The spark is generated at the tip of the OVEN ELECTRODE, which is positioned inside of the pilot burner hood. The spark jumps from the OVEN ELECTRODE to the pilot burner hood, across the pilot gas exit.

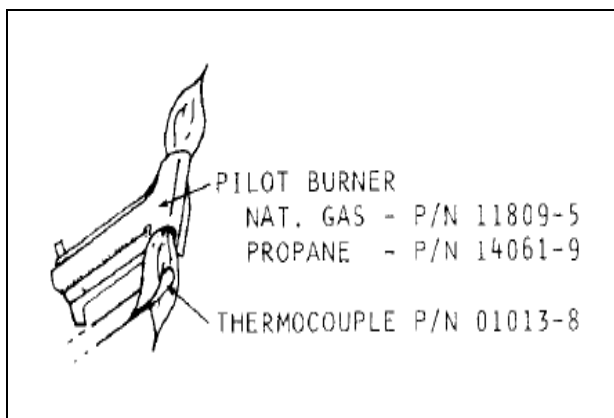

**OVEN PILOT BURNER**  
**Pilot Service in the Event of Pilot Failure**

1. If pilot flame burns yellow, clean pilot orifice and pilot burner to insure a steady blue flame. The orifice can be cleaned by washing in a solvent and/ or blowing out with air.
2. Flame must surround the thermocouple tip for approximately 1/2 inch.

## SERVICE

### THERMOCOUPLE OUTPUT

OPEN CIRCUIT MV RANGE	
NORMAL	NOT LESS THAN
15-25	8

If the closed circuit check shows thermocouple output is greater than 8 millivolts and pilot will not remain lit when button is released, replace safety pilot magnet assembly.

3. Thermocouple lead connections must be tight, clean, and free of grease. The thermocouple nut should be started and turned all the way by hand. An additional quarter turn with a small wrench will be sufficient.

**CAUTION!**  
**OVERTIGHTENING MAY CAUSE DAMAGE TO THE THERMOCOUPLE  
OR MAGNET AND IS UNNECESSARY SINCE THIS IS AN ELECTRIC  
CONNECTION.**

### FRY TOP THERMOSTAT

The model BJ Robertshaw is a combination thermostat and gas valve. The gas is turned on and the temperature setting made by a single rotation of the dial. The valve automatically locks itself in the "OFF" position. To use, push dial inward, rotate counterclockwise to the desired temperature. To shut gas off, rotate clockwise to the "OFF" position.

This thermostat is a precision instrument carefully made and properly calibrated (i.e. the dial is properly set) at the factory to control temperatures accurately. It should control temperatures for the proper cooking of food without recalibration. The calibration of the thermostat should not be changed until considerable experience with cooking results has definitely proved that the thermostat is not maintaining the proper temperature.

**CAUTION!**  
**THE RECALIBRATION SHOULD NOT BE MADE UNTIL THE BYPASS  
(MINIMUM BURNER) FLAME HAS BEEN PROPERLY ADJUSTED.**

**THERMOSTAT INSTALLATION**

With front of the griddle plate raised, slide the thermostat bulb assembly into the support brackets attached to the underside of the Fry Top plate. Tighten the two holding screws. The excess capillary tube should be pulled forward out of the heat zone so that there is no chance of it coming in contact with the burner flame. Push the sleeving up against the bulb holder. A loose fit between the bulb holder and plate may damage the thermostat so that it will not control the temperature of the Fry Top plate accurately.

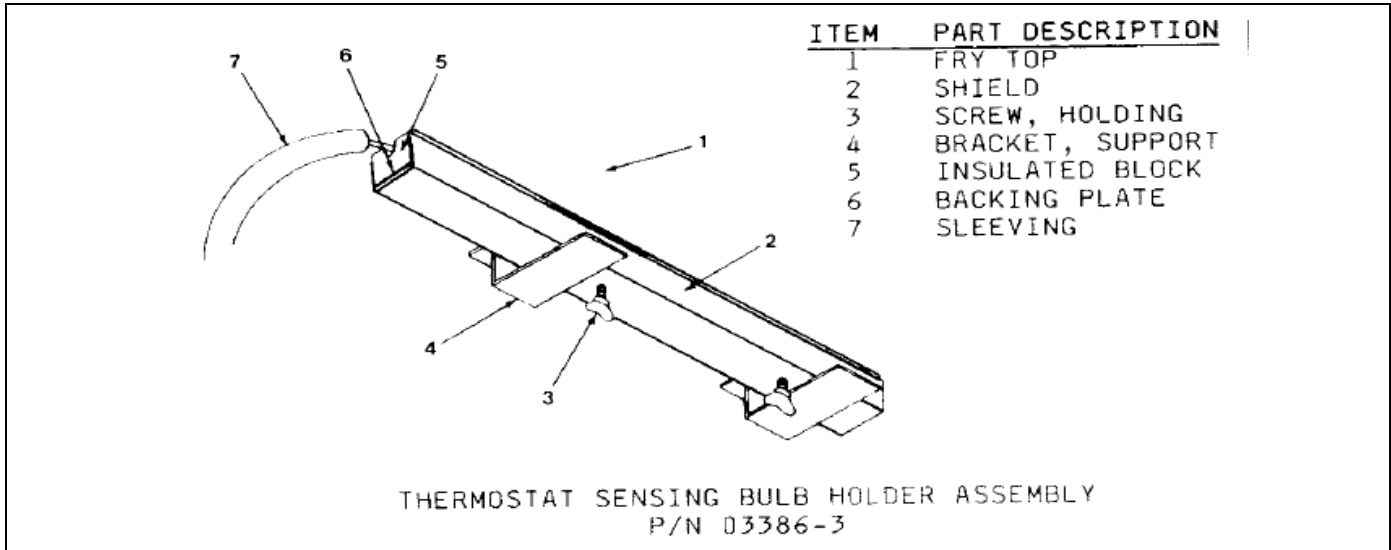

**ADJUSTMENT OF BYPASS (MINIMUM BURNER) FLAME**

This is the flame which must be maintained on the burners when the Fry Top has reached the temperature set on the dial. Enough gas must be bypassed by the control to keep the entire burner lit. The thermostat regulates the flame from high to low in accordance with the Fry Top temperature and will automatically turn down to this bypass flame when the temperature set on the dial is attained.

Special care should be taken to see that the thermostat bulb is in its proper place and no part of the capillary tube is in any flame or heat zone. The Fry Top plate should never be removed without first removing the thermostat bulb(s) from beneath the plate. Never allow capillary tube to be kinked or crushed.

## SERVICE

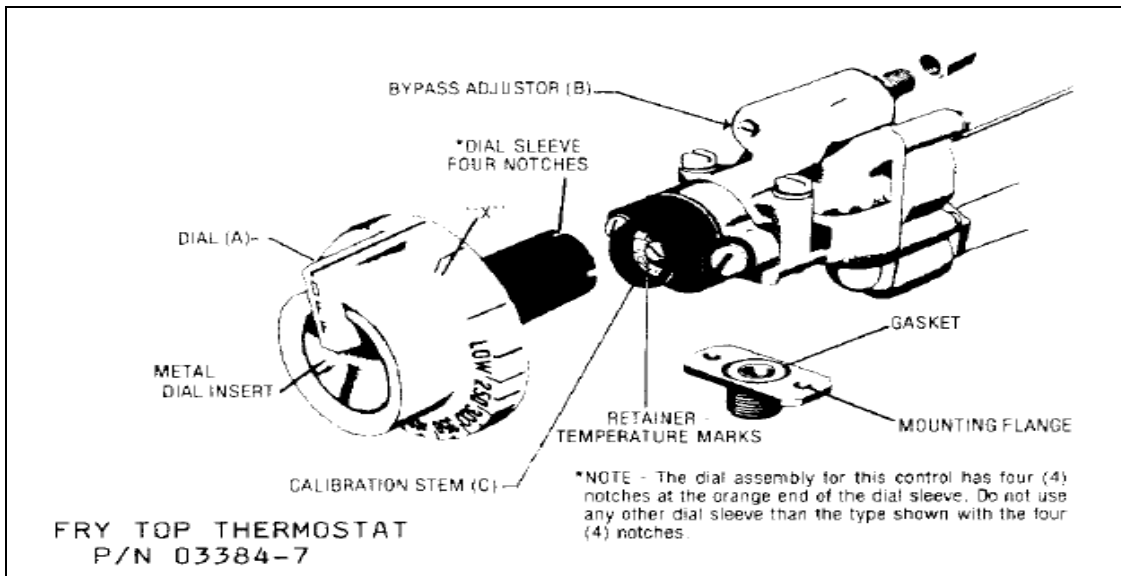

### THE BYPASS MUST BE SET CAREFULLY AND ACCURATELY AS FOLLOWS:

1. Light burners and turn Dial (A) counterclockwise and to a point midway between the “Gas On” mark and the next graduation to the right of it. (shown by “X”). If the burner goes out entirely, the bypass is closed.
2. Slip off Dial (A). Remove the valve panel from the front of the range.
3. With a screwdriver, turn bypass adjustor (B). Turning it out counterclockwise increases the bypass flame; turning it in clockwise decreases the bypass flame. Adjust until there is a flame approximately 1/8” high over the entire burner.
4. Replace dial, rotating dial clockwise until it snaps into its original position.
5. Reinstall the valve panel on front of the range.

### FRY TOP THERMOSTAT CALIBRATION CHECK

The Fry Top temperature should be checked or recalibrated with the fry top hot.

NOTE: See “Adjustment of Bypass (Minimum Burner) Flame” before recalibrating this thermostat.

**HOT CHECK METHOD:**

1. Place reliable thermometer in center of the top of the Fry Top over the thermal bulb.
2. Set Dial (A) to 350°F.
3. Wait until temperature rises and remains constant.
4. If dial does not agree with thermometer readings, slip off Dial (A) and push out metal insert.
5. Replace dial, turn to 350°F mark.
6. Hold dial firmly, insert screwdriver through center of dial and push calibration stem (C) inward. DO NOT TURN THIS STEM.
7. While holding calibration stem (C) in firmly with screwdriver, turn dial until it is set at the actual Fry Top temperature as it is shown by the thermometer. Release pressure on calibration stem. Replace dial insert.

**OVEN THERMOSTAT**

The Model BJ Robertshaw is a combination thermostat and gas valve. The gas is turned on and the temperature setting is made by a single rotation of the dial. This valve automatically locks itself in the “OFF” position. To use, push dial inward, rotate counterclockwise to the desired temperature. To shut gas off, rotate clockwise to “OFF” position.

The thermostat is a precision instrument carefully made and properly calibrated (i.e. the dial is properly set) at the factory to control temperatures accurately. It should control temperatures for the proper cooking of food without recalibration. The calibration of this thermostat should not be changed until considerable experience with cooking results has definitely proved that the thermostat is not maintaining its proper temperature.

**CAUTION!**  
**THE RECALIBRATION SHOULD NOT BE MADE UNTIL THE BYPASS (MINIMUM BURNER) FLAME HAS BEEN PROPERLY ADJUSTED.**

## SERVICE

### ADJUSTMENT OF BYPASS (MINIMUM BURNER) FLAME

This is the flame which must be maintained on the burners when the oven has come up to the temperature set on the dial. Enough gas must be bypassed by the control to keep the entire burner lit. The thermostat regulates the flame from high to low in accordance with the Fry Top temperature and will automatically turn down to this bypass flame when the temperature set on the dial is attained in the oven.

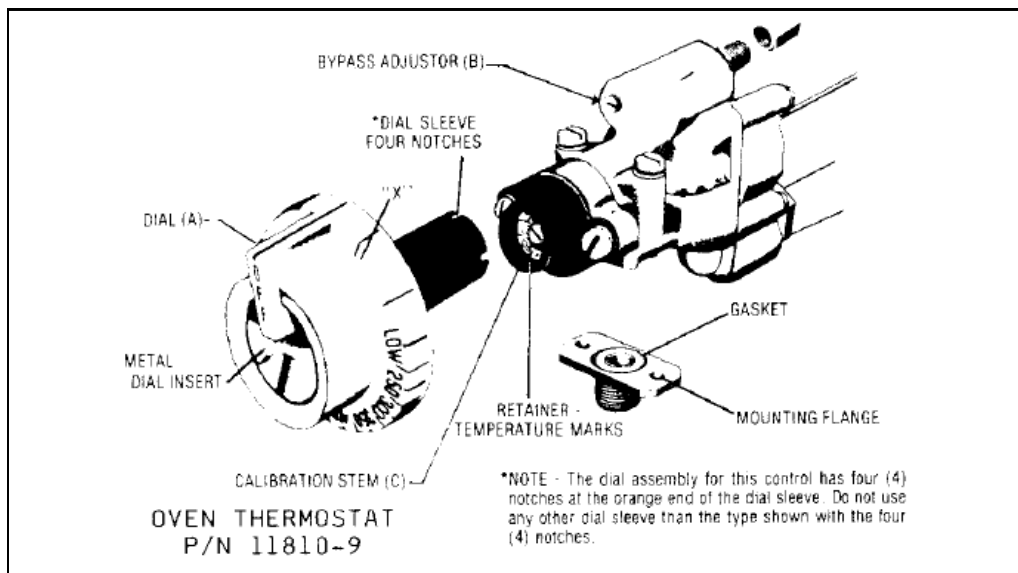

### THE BYPASS MUST BE SET CAREFULLY AND ACCURATELY AS FOLLOWS:

1. Light burners and turn Dial (A) counterclockwise and to a point midway between the "Gas On" mark and the next graduation to the right of it. (shown by "X"). If the burner goes out entirely, the bypass is closed.
2. Slip off Dial (A). Remove the valve panel from the front of the range.
3. With a screwdriver, turn bypass adjustor (B). Turning it out counterclockwise increases the bypass flame; turning it in clockwise decreases the bypass flame. Adjust until there is a flame approximately 1/8" high over the entire burner.
4. Replace dial, rotating dial clockwise until it snaps into its original position.
5. Reinstall the valve panel on front of the range.

**OVEN THERMOSTAT CALIBRATION CHECK**

The oven temperature should be checked or recalibrated with oven hot. NOTE: See “Adjustment of Bypass (Minimum Burner Flame” above before recalibrating this thermostat.

**HOT CHECK METHOD:**

1. Place reliable thermometer in center of oven.
2. Set Dial (A) to 350°F.
3. Wait until temperature rises and remains constant.
4. If dial does not agree with thermometer readings, slip off Dial (A) and push out metal insert.
5. Replace dial, turn to 350°F mark.
6. Hold dial firmly, insert screwdriver through center of dial and push calibration stem (C) inward. DO NOT TURN THIS STEM.
7. While holding calibration stem (C) in firmly with screwdriver, turn dial until it is set at the actual oven temperature as it is shown by the thermometer. Release pressure on calibration stem. Replace dial insert.

**GAS PRESSURE REGULATOR**

**WARNING**  
**NO UNTRAINED PERSON SHOULD ATTEMPT TO MAINTAIN OR SERVICE THE GAS PRESSURE REGULATOR.**

**ORIFICE SIZE CHART— DRILL SIZE**

	INPUT RATING BTU/HR	NATURAL GAS 6.0 i.w.c.	PROPANE GAS 10.0 i.w.c
G26 OVEN	35,000	39	51
G16	20,000	48	55
VG26 OVEN	40,000	37	50
OPEN TOP	20,000	48	55
	25,000	45	N/A
FRY TOP	20,000	48	55
HOT TOP	20,000	48	55
COMB. FRY TOP/ BROILER	18,000	50	56

## **SERVICE**

---

### **OPERATIONAL DIFFICULTIES AND PROBABLE CAUSES**

#### **Oven Pilot Burner Goes Out:**

1. Gas shut off.
2. Poor draft in flue snuffs out flame.
3. Too much draft pulls flame away from thermocouple.
4. Pilot flame too low.
5. Thermocouple defective.
6. Thermocouple connection on safety pilot valve loose.
7. Pilot orifice dirty.
8. Safety pilot valve defective.
9. Gas leak at pilot orifice fitting.
10. Restricted or plugged vent on gas pressure regulator.
11. Incorrect gas pressure setting on pressure regulator.
12. Make up air blowing at flue outlet.

#### **Oven Burner Fails to Come On:**

1. Burner valve off.
2. Burner orifice plugged.
3. Thermostat out of calibration.
4. Minimum flame adjustment closed and thermostat setting too low.

#### **Oven Temperature Higher Than Dial Setting:**

1. Oven thermostat out of calibration.
2. Minimum flame too high. (Do not lower under 1/8").
3. Broken capillary tube on thermostat.
4. Dirt under thermostat valve seat.

# Montague Frytop Section, Manual Control-Exploded View

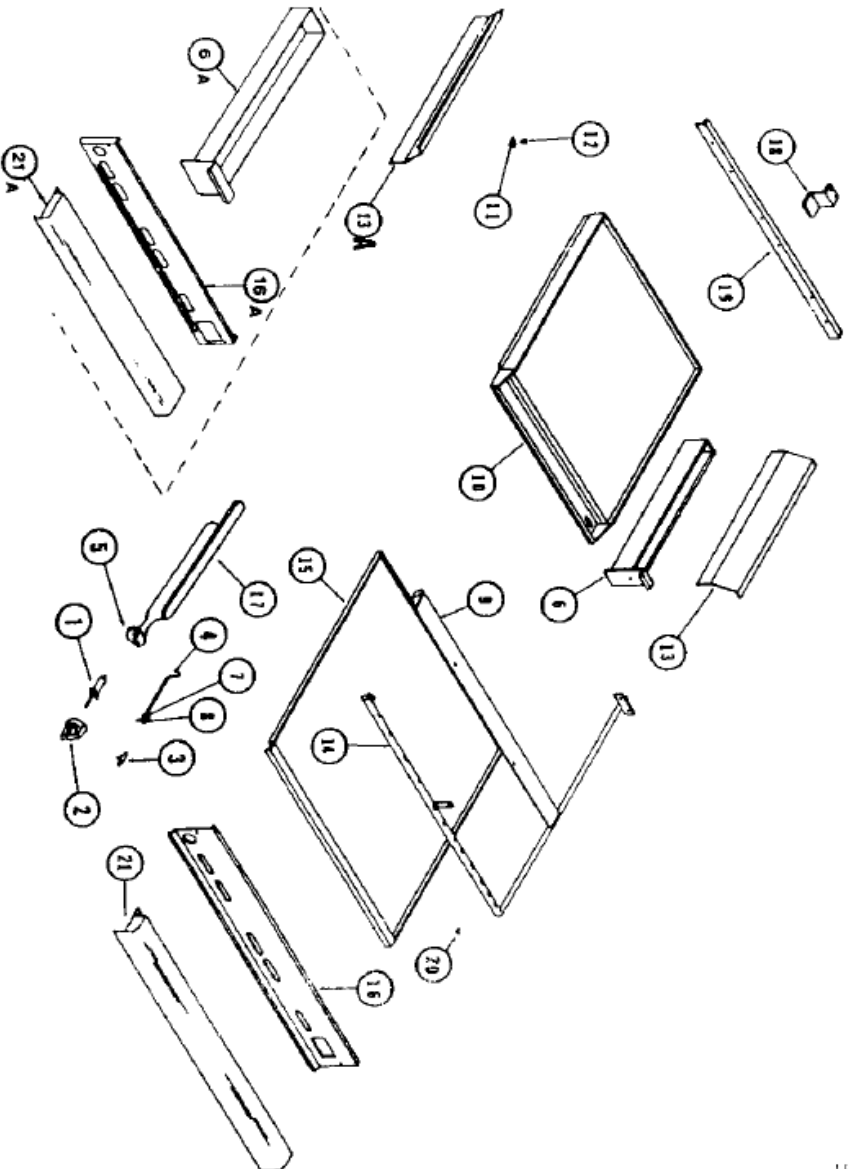

Item Part #	Description
1 ... 02403-1	Valve, Top Burner-NAT. (4.0"W.C)
... 01006-5	Valve, Top Burner-LP (10.0"W.C)
... 14608-0	Valve, Top Burner-NAT.(6.0"W.C, Chg. #1)
2 ... 11790-0	Handle, Valve-Blue
3 ... 01055-3	Valve, Pilot Adjustment
4 ... 03415-0	Lighter, Pilot
5 ... 02038-9	Air Mixer
6 ... 14127-5	Grease Container, Frytop
7 ... 02202-0	Nut, Compression-3/16"
8 ... 02203-9	Sleeve, Compression-3/16"
9 ... 11875-3	Shield, Front Valve-(34" unit)
10 ... 14123-2	Frytop-1ft
... 14122-4	Frytop-2ft
... 14111-9	Frytop-3ft
... 14119-4	Frytop-4ft
... 14120-8	Frytop-5ft
... 14114-3	Frytop-6ft
11 ... 01920-8	Nut, Retainer
12 ... 01869-4	Bolt, Adjusting-Frytop
13 ... 14043-0	Deflector, Drip-Right
13A ... 14039-2	Deflector, Drip-Left
14 ... 14027-9	Manifold Assy-(34"unit)
15 ... 04485-7	Container, Drip-Pan
16 ... 14126-7	Panel, Control
17 ... 03361-8	Burner Assy, Complete-1ft only
18 ... 14146-1	Support Burner-Rear
19 ... 14042-2	Angle, Rear Structural-(34"unit)
20 ... 01279-3	Plug, Manifold-1/8"
21 ... 11787-0	Rail, Front Guard-(34"unit)

## 25 KBTU Manual Frytop Style

6A ... 28045-3 ... Grease Container, Frytop-25 KBTU

# Montague Frytop Section, Manual Control-Exploded View

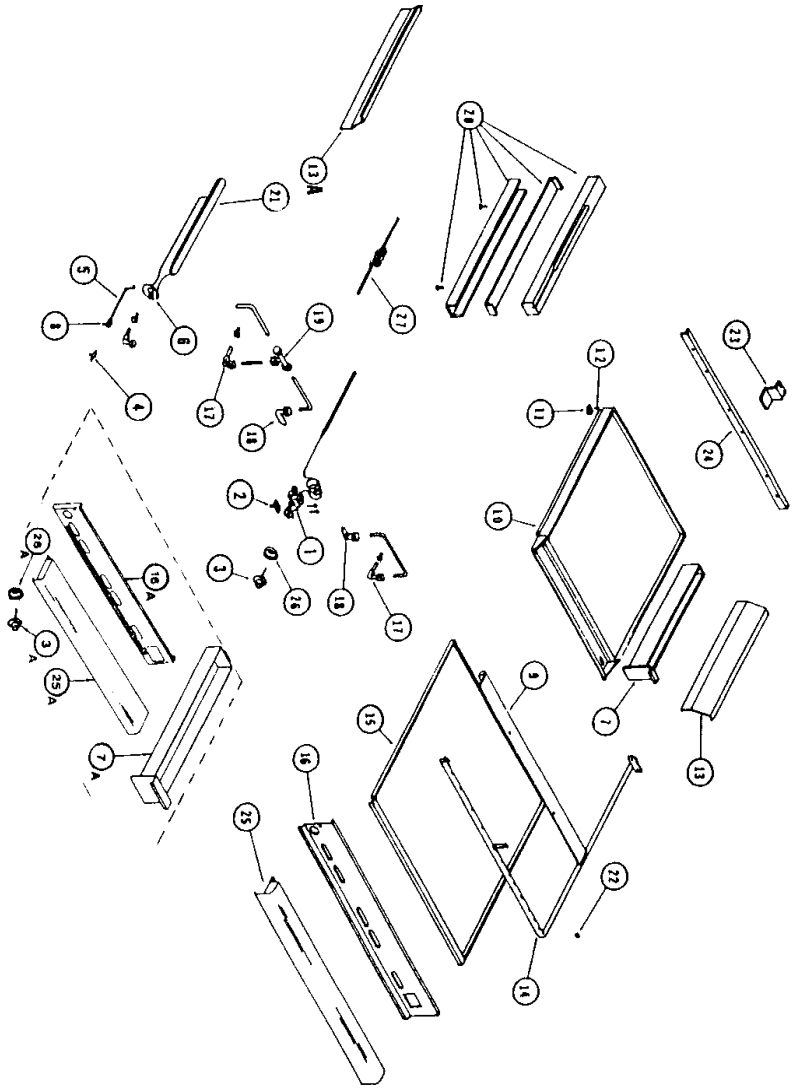

**Item Part # Description**

1	03384-7	Thermostat, BUWA
2	02336-1	Nipple, Flange Mount
3	09182-8	Dial, Thermostat
4	01055-3	Valve, Pilot Adjustment
5	03415-1	Lighter, Pilot
6	02038-9	Air Mixer
7	14127-5	Grease Container, Frytop
8	02202-0	Nut, Compression-3/16"
	02203-9	Sleeve, Compression-3/16"
9	11875-3	Shield, Front Valve-(34"unit)
10	15982-4	Frytop-1ft
	15988-3	Frytop-2ft
	15981-6	Frytop-3ft
	15983-2	Frytop-4ft
	15984-0	Frytop-5ft
	15985-9	Frytop-6ft
11	01920-8	Nut, Retainer
12	01869-4	Bolt, Adjusting-Frytop
13	14043-0	Deflector, Drip-Right
13A	14039-2	Deflector, Drip-Left
14	17441-6	Manifold Assy-(34"unit)
15	04485-7	Container, Drip-Pan
16	14126-7	Panel, Control
17	02411-2	Orifice, Elbow Assy-NAT.(4.0 WC)
	14612-9	Orifice, Elbow Assy-NAT.(6.0 WC, Chg. #1)
	03385-5	Orifice, Elbow Assy-LP
18	01285-8	Elbow, Mate-1/4" x 3/8" cc
19	01286-6	Tee, Tubing-3/8" cc
20	03386-3	Holder Assy, Sensing Bulb
21	03361-8	Burner Assy-1ft only
22	01279-3	Plug, Manifold-1/8"
23	14146-1	Support, Burner-Rear
24	14042-2	Angle, Rear Structural-(34"unit)
25	11787-0	Rail, Front Guard-(34"unit)
26	01985-2	Bezel, Thermostat
27	07125-0	Insulation Sleeving, T'stat Bulb

**25 KBTU Thermostat Frytop Style**

3A	26869-0	Dial, Thermostat-25 KBTU
7A	28045-3	Grease Container Frytop-25 KBTU
16A	26901-8	Panel, Control-25 KBTU
25A	26674-4	Rail, Front Guard-25 KBTU
26A	26870-4	Bezel, Thermostat-25 KBTU



The Montague Company  
1830 Stearman Avenue, P.O. Box 4954, Hayward, CA 94540-4954

# Montague Open Top Section—Exploded View

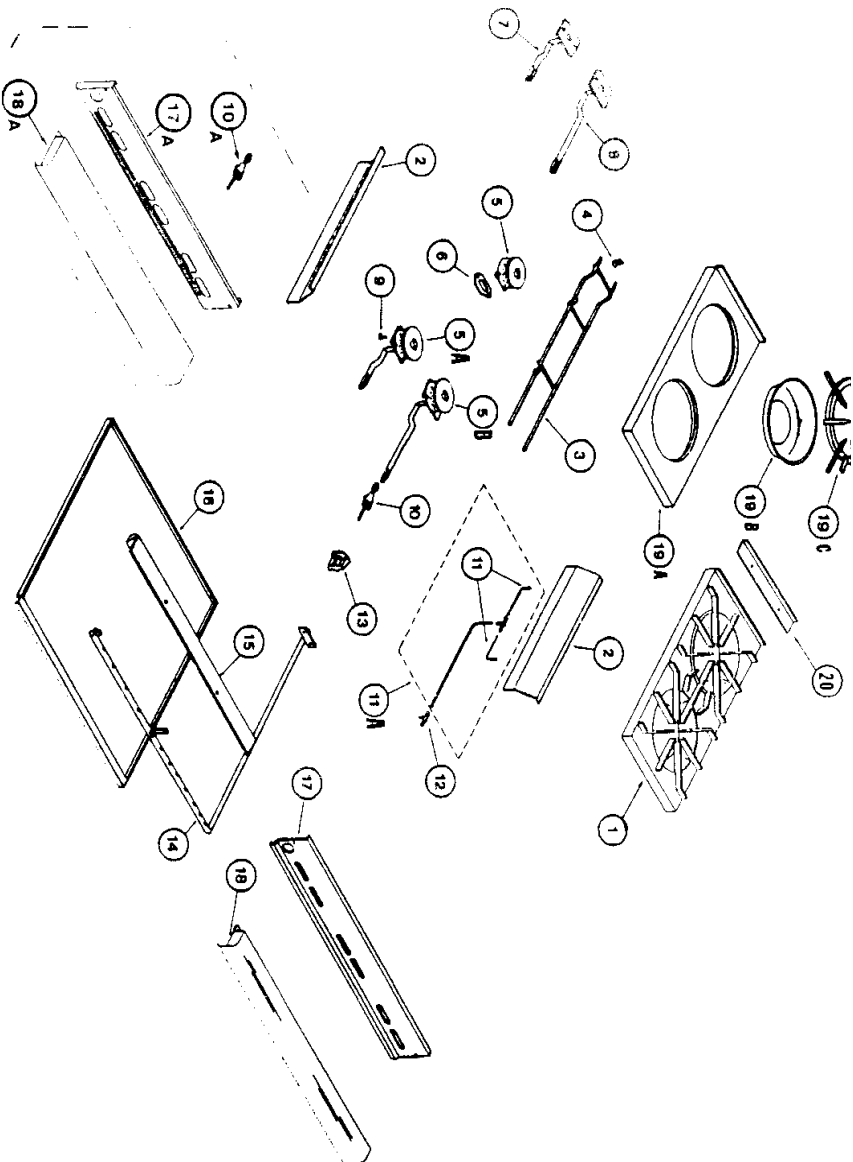

Item	Part #	Description
1	25429-0	Cast Iron Top
2	14040-6	Deflector, Drip
3	18873-7	Support, Burner
4	01388-9	Clamp, Burner Support
5	03371-5	Burner, Head-Round
5A	15589-6	Burner, Front-Complete
5B	15591-8	Burner, Rear-Complete
6	02115-6	Gasket, Burner
7	11778-1	Venturi-Front Burner
8	11777-3	Venturi-Rear Burner
9	06976-0	Screw, Cap-Burner
10	02403-1	Valve, Top Burner-NAT (4.0"WC)
	01006-5	Valve, Top Burner-LP (10.0"WC)
	14608-0	Valve, Top Burner-NAT (6.0"WC, Chg # 1)
11	14051-1	Lighter, Pilot
11A	14033-3	Pilot Kit, Open Top-(Less Valve)
12	01055-3	Valve, Pilot Adjustment
13	11790-0	Handle, Valve-(Blue)
14	14027-9	Manifold Assy-(34"unit)
15	11875-3	Shield, Front Valve-(34"unit)
16	04485-7	Container, Drip-(34"unit)
17	14062-7	Panel, Control-(34"unit)
18	11787-0	Rail, Front Guard-(34"unit)
19A	11834-6	Open Top Section-(2 hole)
19B	01551-2	Bowl, Burner
19C	11758-7	Grate, Top
20	23146-0	Stop, Angle Bracket-(SGL)
	23180-0	Stop, Angle Bracket-(DBL)
	23181-9	Stop, Angle Bracket-(TRPL)

## 25 KBTU Open Top Style

10A	02570-4	Valve, Top Burner
17A	26888-7	Panel, Control-(34"unit)-25 KBTU
18A	26674-4	Rail, Front Guard-(34"unit)-25 KBTU



**The Montague Company**  
1830 Stearman Avenue, P.O. Box 4954, Hayward, CA 94540-4954

# Montague Grizzly G26 Oven —Exploded View

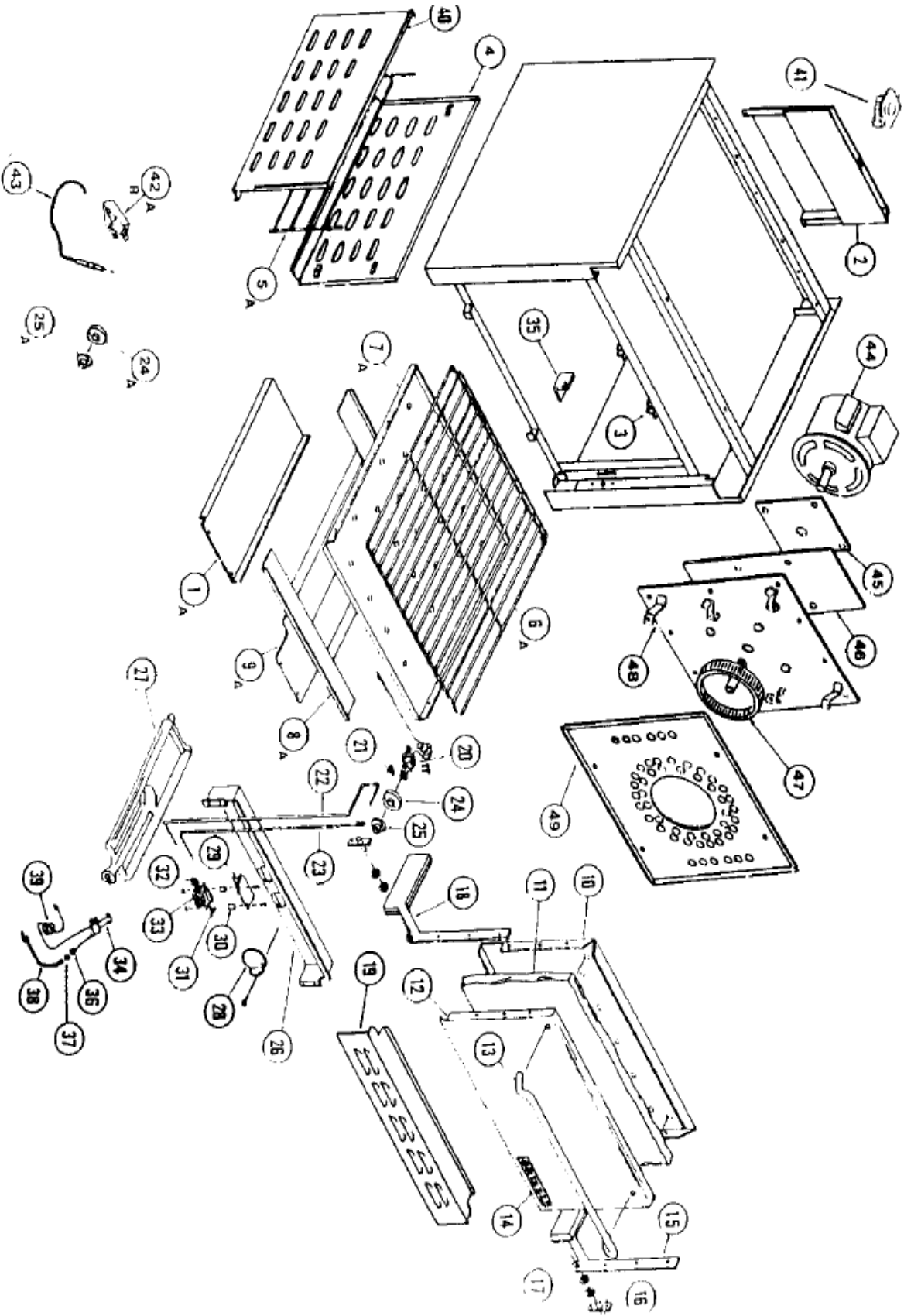



## **WARNING**

**If not installed, operated, and maintained in accordance with the manufacturer's instructions, this product could expose you to substances in fuel or in fuel combustion which can cause death or serious illness and which are known to the State of California to cause cancer, birth defects or other reproductive harm.**

The State of California enacted the California Safe Drinking Water and Toxic Enforcement Act of 1986, (Prop. 65), which "prohibits any person in the course of doing business from knowingly and intentionally exposing any individual to a chemical known to the State of California to cause cancer or reproductive toxicity without first giving clear and reasonable warning to such individuals." The Governor's Scientific Advisory Panel added carbon monoxide to the list of hazardous chemicals known to cause reproductive harm.

In order to establish full compliance with Proposition 65, we attached a yellow warning label to each gas fired unit manufactured by the Montague Company.

Carbon monoxide would not be present in concentrations that would pose a "significant risk" to the consumer when the equipment is installed, operated and maintained as follows:

1. Installed in accordance with all local codes, or in the absence of local codes, with the current National Fuel Gas Code Z223.1.
2. Installed under a properly designed and operating exhaust hood.
3. Connected to the type of gas for which the unit is equipped.
4. Proper appliance pressure regulator installed on the gas supply line and adjusted for the manifold pressure marked on the rating plate.
5. Adequate air supply to the unit.
6. The equipment is operated in the manner intended using the proper utensil for that type of appliance.
7. Keep the equipment clean and have it checked periodically.
8. Burner air adjustments, mechanical maintenance and repairs should be performed by qualified service personnel.

If the equipment is not installed, operated and maintained in accordance with the above, concentrations of carbon monoxide in excess of the established limits could present in the kitchen environment.

ALL PERSONNEL IN THE WORKPLACE WHO MAY BE SUBJECT TO ANY EXPOSURE OF CARBON MONOXIDE MUST BE WARNED OF SUCH POSSIBLE EXPOSURE. THIS WARNING SHOULD BE CONVEYED IN A MANNER SO THAT IT IS CLEARLY UNDERSTOOD BY THE EMPLOYEE, AND THE EMPLOYEE SHOULD BE ASKED IF IN FACT HE OR SHE UNDERSTANDS THE CORRECT METHOD OF OPERATION OF THE EQUIPMENT AND THAT A RISK OF EXPOSURE EXISTS IF THE EQUIPMENT IS OPERATED IMPROPERLY.



**The MONTAGUE COMPANY**

1830 Stearman Avenue, P.O. Box 4954 Hayward, CA 94540-4954

# **IMPORTANT**

When ordering parts, to eliminate mistakes and facilitate delivery, always give the following information:

Serial No. \_\_\_\_\_

Model No. \_\_\_\_\_

Change No. \_\_\_\_\_

## **Name & No. of Part**

**Model No.    Change No.    Serial No.**

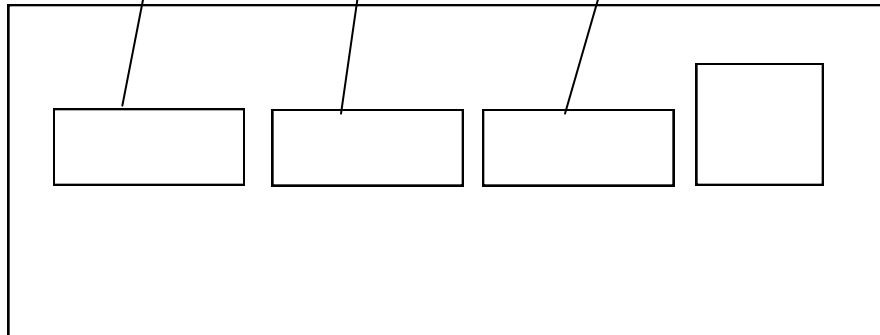

“VG Series” Rating Plate

The Montague Company  
1830 Stearman Avenue  
P.O. Box 4954  
Hayward, CA 94540-4954

P/N 14510-6    10/97