

INSTRUCTION MANUAL

INSTALLATION / OPERATIONS / PARTS & SERVICE

MONTAGUE REFRIGERATION AND FREEZER BASES



MODEL(S):

RB36SC—RB108SC

RB36R—RB108R

RB36 FREEZER—RB108 FREEZER

**These instructions should be read thoroughly before attempting installation.
Set up and installation should be performed by qualified installation personnel.**

**PLEASE RETAIN THIS MANUAL
FOR FUTURE REFERENCE.**

THE MONTAGUE COMPANY

1830 Stearman Avenue

P.O. BOX 4954

Hayward, CA 94540-4954

TEL: (510) 785-8822 FAX: (510) 785-3342



IMPORTANT

WARNING:

Improper installation, adjustment, alteration, service or maintenance can cause property damage, injury or death. Read the operating and maintenance instructions thoroughly before installing or servicing this equipment.

FOR YOUR SAFETY:

Do not store or use gasoline or other flammable vapors and liquids in the vicinity of this or any other appliance.

INSTRUCTIONS TO BE FOLLOWED IN THE EVENT THE USER SMELLS GAS MUST BE POSTED IN A PROMINENT LOCATION. THIS INFORMATION MAY BE OBTAINED BY CONSULTING THE LOCAL GAS SUPPLIER.

SHIPPING DAMAGE CLAIM PROCEDURE

For your protection, please note that equipment in this shipment was carefully inspected and packed by skilled personnel before leaving the factory. The transportation company assumes full responsibility for safe delivery upon acceptance of this shipment.

If shipment arrives damaged:

1. **VISIBLE LOSS OR DAMAGE**—Be certain this is noted on freight bill or express receipt, and signed by person making delivery.
2. **FILE CLAIM FOR DAMAGES IMMEDIATELY**—Regardless of the extent of damage.
3. **CONCEALED LOSS OR DAMAGE**—If damage is unnoticed until merchandise is unpacked, notify transportation company or carrier immediately, and file “concealed damage” claim with them. This should be done within fifteen (15) days of date that delivery was made to you. Be sure to retain container for inspection.

We cannot assume responsibility for damage incurred in transit. We will, however, be glad to furnish you with necessary documents to support your claim.

The Refrigeration and Freezer bases are produced with the best possible material and workmanship. PROPER INSTALLATION IS ESSENTIAL FOR SAFE AND EFFICIENT TROUBLE-FREE OPERATION.

THE INSTALLATION INSTRUCTIONS CONTAINED HEREIN ARE FOR THE USE OF QUALIFIED INSTALLATION AND SERVICE PERSONNEL ONLY. INSTALLATION OR SERVICE BY OTHER THAN QUALIFIED PERSONNEL MAY RESULT IN DAMAGE TO THE EQUIPMENT AND/OR INJURY TO THE OPERATOR.

Qualified installation personnel are individuals, a firm, corporation or company which either in person, or through a representative are engaged in, and are responsible for:

- A. The installation or replacement of the connection, installation, repair or servicing of equipment, who is experienced in such work, familiar with all precautions required, and has complied with all requirements of state or local authorities having jurisdiction. Reference: National Fuel Gas Code Z223.1-latest addenda, Section 1.4.

- B. The installation of electrical wiring from the electric meter, main control box or service outlet to the electric appliance. Qualified personnel must be experienced in such work, be familiar with all precautions required and have complied with all requirements of state and local authorities having jurisdiction. Reference: National Electric Code, N.F.P.A. No. 70-latest addenda.

READ CAREFULLY AND FOLLOW THESE INSTRUCTIONS

THIS UNIT WHEN INSTALLED MUST BE ELECTRICALLY GROUNDED IN ACCORDANCE WITH LOCAL CODES, OR IN ABSENCE OF LOCAL CODES, WITH THE NATIONAL ELECTRICAL CODE, ANSI/NFPA No.70-LATEST ADDENDA.

PROVISIONS MUST BE MADE FOR ADEQUATE AIR SUPPLY TO THE UNIT.

INTRODUCTION

NOTE: Sections of this manual are prepared for the use of Service Technicians and should not be used by those not properly qualified. This manual is not intended to be all encompassing. You should read, in its entirety, the repair procedure you wish to perform to determine if you have the necessary tools, instruments, and skills required to perform the procedure.

MONTAGUE MODELS

Montague RB-SC and RB-R models are refrigerated Equipment Stand units available in different lengths from 36 to 108 inches in width. These units are available as refrigerated or freezer storage compartments. The condensing systems are designed to be installed with minimal clearance to walls or other equipment.

These models are available as self-contained or remote. Standard features on these models include:

- Electronic temperature control
- All stainless steel construction
- 6” legs for (RB-R) models
- Double or single wide drawers
- Exterior Top Rail thermometer
- Display: 3 digit display w/ sign (-199 to 999) and decimal point.
- Six status LED's
- Unique designed evaporator coil (TURBO COIL). controlled from the outside thermometer

MODELS AVAILABLE

SELF-CONTAINED	REMOTE	SELF-CONTAINED	REMOTE
(RB-SC)	(RB-R)	(FB-SC)	(FB-R)
RB-36-SC	RB-36-R	FB-36-SC	FB-36-R
RB-48-SC	RB-48-R	FB-48-SC	FB-48-R
RB-60-SC	RB-60-R	FB-60-SC	FB-60-R
RB-72-SC	RB-72-R	FB-72-SC	FB-72-R
RB-84-SC	RB-84-R	FB-84-SC	FB-84-R
RB-96-SC	RB-96-R	FB-96-SC	FB-96-R
RB-108-SC	RB-108-R	FB-108-SC	FB-108-R

* Available options include: Marine edge exterior top in all different models.

TABLE OF CONTENTS

THE SERIAL TAG	PAGE 6
RECEIVING & INSPECTING	PAGE 7
A. UNPACKING AND CHECKING	
INSTALLATION	PAGE 7 & 8
A. UNPACK LOOSE COMPONENTS	
B. REFRIGERATION LINES	
C. ELECTRIC CONNECTION	
OPERATION	PAGE 8
A. TEMPERATURE SETTING	
B. FREEZER SETTING	
C. THERMOSTAT	
D. DEFROST	
E. SHUTTING OFF	
DRAWER CONFIGURATION	PAGE 9 & 10
MAINTENANCE PROCEDURES	PAGE 11
A. CLEANING STORAGE CABINET	
B. STORAGE CABINET	
C. CONDENSING UNIT	
TROUBLESHOOTING GUIDE	PAGE 12
WIRING DIAGRAM (RB-SELF CONTAINED) ...	PAGE 13
WIRING DIAGRAM (RB-REMOTE)	PAGE 14
WIRING DIAGRAM (FB-SELF CONTAINED)	PAGE 15
WIRING DIAGRAM (FB-REMOTE).....	PAGE 16
EXPLODED VIEWS & PARTS LISTS	PAGE 17-25

THE SERIAL TAG

The serial tag is a label permanently affixed to every unit on which vital electrical and refrigeration data about your Montague product, is recorded as well as model and serial number. This tag is located inside the storage cabinet on all standard Self-contained (RB-SC) or Remote (RB-R) model refrigerated equipment stand units. Prior to installation, test the electrical service to assure that it agrees with the specifications of the equipment marked on the serial tag.

READING THE SERIAL MODEL:

- Serial = The permanent ID# of your Montague unit
- Model = The model # of your Montague unit
- Volts = Voltage
- Hz = Cycle
- Heaters (freezers only) = Number of Heaters
- Total Amps = Maximum Amp draw
- Minimum Circuit = Minimum Circuit Ampacity
- Maximum Amps Protection = Breaker size
- Refrigerant = Refrigerant type and amount used
- Design Pressure = Maximum operating pressures

EXAMPLE:

THE MONTAGUE CO.
HAYWARD – CALIFORNIA

MOD:
SER:

VOLTS: HZ: PH:
TOTAL AMPS:

MIN CIRCUIT AMPACITY:

DESIGN PRESSURE
(PSIG)

HIGH SIDE: LOW SIDE:
REFRIGERANT: LBS: OZ:

A TYPE II DISPLAY REFRIGERATOR OR FREEZER
INTENDED FOR OTHER THAN HOUSEHOLD USE.
(DESTINE A UN USAGE AUTRE QUE
DOMESTIQUE.)
P/N:59935-2

Figure 1.

SERIAL NUMBER LOCATION

Always have the serial number of your unit available when calling Parts & Service.

The serial number is on the nameplate that also includes the model number. A typical identification plate is shown in Figure 1.

RECEIVING & INSPECTING

SHIPPING DAMAGE CLAIM PROCEDURE

NOTE: For your protection, please note that equipment in this shipment was carefully inspected and packed by skilled personnel before leaving the factory. The transportation company assumed full responsibility for safe delivery upon acceptance of this shipment.

*** We cannot assume responsibility for damage incurred in transit. We will, however, be glad to furnish you with the necessary documents to support your claim.**

All Montague products are factory tested for performance and are free from defects when shipped. The utmost care has been taken in crating this product to protect against damage in transit.

You should carefully inspect your Montague unit for damage during delivery. If damage is detected, you should save all the crating materials and make note on the carriers Bill of Lading describing the damage. A freight claim should be filed immediately. There is a fifteen (15) day limit to file freight damage with the carrier. (to verify)

Care should be taken during unloading so the equipment is not damaged while being moved into the building.

1. Visually inspect the exterior of the package and skid or container. Any damage should be noted and reported to the delivery carrier immediately.
2. If damaged, open and inspect the contents with the carrier.
3. In the event the exterior is not damaged, yet upon opening, there is concealed damage to

the equipment, notify the carrier. Notification should be made verbally as well as in written form.

4. Request an inspection by the shipping company of the damaged equipment. This should be done within 10 days from receipt of equipment.
5. Freight carriers can supply the necessary damage form upon request.
6. Retain all shipping materials until an inspection has been made or waived.

INSTALLATION

- A. Uncrate unit as near to final location as possible for easier and lighter handling of the unit and remove all packing materials from interior.

Some components are packed and shipped inside the storage cabinet to avoid damage during shipment. Remove these items from the cabinet and remove packing materials. (CASTERS, LEGS, ETC.)

- B. FOR CORD CONNECTED UNITS (Self-contained models): Plug the unit into a properly sized outlet. See data plate location inside storage cabinet for circuit sizing.

- C. **WARNING: THIS UNIT IS PROVIDED WITH A THREE PRONGED GROUNDING PLUG. THE OUTLET TO WHICH THIS PLUG IS CONNECTED MUST BE PROPERLY GROUNDED. IF RECEPTACLE IS NOT THE PROPER GROUNDING TYPE, CONSULT ELECTRICIAN FOR PROPER INSTALLATION.**

- D. PERMANENTLY WIRED UNITS (Remote Models): A junction box located on the back of the unit is provided for electrical field

INSTALLATION(CONTINUED)

connections. See wiring diagram shipped with the unit on the compressor compartment behind the louver panel for electrical rating.

E. REFRIGERATION LINES (Remote units only)

WARNING: REFRIGERATION LINES ARE SHIPPED UNDER PRESSURE. USE CAUTION WHEN OPENING LINES.

F. ON REMOTE UNITS. Refrigeration lines for suction and supply are located on the back of the unit. The suction line is marked "suction" and 3/8 copper tubing. The liquid supply line is 1/4" copper. If upon opening lines, no release of charge is evident, contact your local authorized service agent immediately.

Cut refrigeration tubing with appropriate tool and de-burr end of the tube. Clean tubing prior brazing connection. Use Silfos 5% refrigerant line brazing or better.

OPERATION

A. TEMPERATURE CONTROL SETTINGS: On both Self-Contained and Remote Refrigerated units, temperature Control should be set 35°F with a 5°F differential. This display should read between 35°F to 40°F . The temperature control setting is "locked" to avoid unauthorized adjustments. Therefore, adjustments to the set point must be made by an authorized service technician.

B. ON FREEZER BASE UNITS: The temperature control should be set at 0°F with 5°F differential. Temperature display should read between 0°F and 5°F

C. The temperature control is the actual thermometer of the unit, it does display the actual temperature of the storage cabinet. Allow cabinet to reach normal operating temperature before loading (approximately) 20 minutes for refrigerator and 45 minutes for freezer. If the storage cabinet is overloaded with warm food products, a certain amount of time is required to remove heat from items before operating temperatures can be maintained. The system is designed for storage of refrigerated or frozen products.

D. DEFROST TIME SETTINGS: All models are provided with an electronic temperature control which have a built-in defrost system, which is factory set as well as the temperature settings. Any change made to the setting must be made by a qualified or authorized service technician.

E. SHUTDOWN FOR EXTENDED PERIODS: If the units are not to be used for an extended period of time, disconnect the electrical power supply and remove the drawers from the storage cabinet. As soon as cabinet has warmed to room temperature, wipe out the base interior.

AVAILABLE DRAWER CONFIGURATION

DRAWER CONFIGURATION (A)	DRAWER CONFIGURATION (B)	DRAWER CONFIGURATION (C)
Can accommodate up to one 6" (152mm) deep, 12" x 20" (305 x 508mm)	Can accommodate up to two pans 6" (152mm) deep, 12" x 20" (305 x 508mm) *(from left to right)	Can accommodate up to two pans 6" (152mm) deep, 12" x 20" (305 x 508mm) *(from front to back)

- Heavy 14-gauge stainless steel track system
- Recessed drawer handles
- Drawers are easily removed for cleaning
- 300lbs (136 kg) individual drawer weight capacity
- Tandem 2" (51mm) diameter stainless steel wheel

Self-Contained Model Guide

Model Number	Unit Width Inches (mm)	Drawers: Width & Configuration			Total Pans
		14-3/8" (356mm)	22-3/8" (566mm)	27-1/4" (692mm)	
RB-36-SC	36" (914)	A			2
RB-48-SC	48" (1219)			C	4
RB-60-SC	60" (1524)	A	B		6
RB-72-SC	72" (1829)		B	C	8
RB-84-SC	84" (2134)			C	8
RB-96-SC	96" (2438)		B - (2)	C	12
RB-108-SC	108" (2743)			C - (3)	12

AVAILABLE DRAWER CONFIGURATION

Remote Model Guide

Model Number	Unit Width Inches (mm)	Drawer: Width & Configuration			Total Pans
		14-3/8" (356mm)	22-3/8" (566mm)	27-1/4" (692mm)	
RB-36-R	36" (914)			C	4
RB-48-R	48" (1219)	A	B		6
RB-60-R	60" (1524)		B	C	8
RB-72-R	72" (1829)			C - (2)	8
RB-84-R	84" (2134)		B - (2)	C	12
RB-96-R	96" (2438)			C - (3)	12
RB-108-R	108" (2743)		B - (3)	C	16

MAINTENANCE PROCEDURES

A. CLEANING: STORAGE CABINET

WARNING: DISCONNECT ELECTRICAL POWER SUPPLY BEFORE CLEANING ANY PARTS OF THE UNIT.

B. STORAGE CABINET: Remove the drawer from the drawer frame modules, use warm soapy water to clean storage cabinet doors. **NEVER** use cleaners containing gritty, abrasive materials, bleach or harsh chemicals. Rinse thoroughly and dry with a clean soft cloth. Always rub in the same direction as the grain pattern of the stainless steel.

WARNING: DISCONNECT ELECTRICAL POWER SUPPLY BEFORE CLEANING ANY PART OF THE UNIT

The condensing unit coil must be cleaned regularly on self-contained models for optimal performance. The operating environment will affect the required frequency of cleaning. However, the condenser should be cleaned at minimum of once every 6 months. Air must be able to freely circulate through the condenser. Unit performance and operating efficiency are significantly affected by the amount of the air passing through the condenser. Condenser fins that are clogged with dirt and grease greatly reduce required heat transfer to air flow. Failure to keep the condenser clean may cause premature compressor failure, which will not be covered by the warranty. The condensing unit is located behind the louvered panel in the compressor compartment. Remove panel by lifting it up and pulling the bottom out. Carefully clean dirt and lint from the condenser coil using a vacuum cleaner or soft brush. **Do not use a wire brush.** An approved condenser degreaser must be used to remove grease. Replace louvered panel by installing top of the panel into

track and pushing in the bottom so it fits inside the opening, reconnect electrical supply.

D. EVAPORATOR COILS:

WARNING: DISCONNECT ELECTRICAL POWER SUPPLY BEFORE CLEANING ANY PARTS OF THE UNIT.

Evaporator coils should be cleaned as required for optimal performance.

The evaporator coils are located in the storage cabinet behind the coil cover. With a 1/4" driver, remove 2 screws holding the cover and remove cover. Clean evaporator coils with a vacuum cleaner or soft brush. Replace coil cover. Reconnect electrical supply.

TROUBLESHOOTING

PROBLEM	POSSIBLE CAUSE
1. Compressor fails to operate	<ul style="list-style-type: none"> • Power failure • Plug in loose receptacle or unplugged • Blown fuse or tripped circuit breaker • Main power switch is off • Temperature control not set properly
2. Condensing unit operates for prolonged periods or continuously	<ul style="list-style-type: none"> • Door gaskets not sealing properly • Condenser dirty • Evaporator coil is iced up or dirty • Prolonged and/or frequent door openings or door(s) ajar • Excessive load of warm food placed into lower storage cabinet
3. Lower storage cabinet not holding temperature	<ul style="list-style-type: none"> • Temperature control not set properly • Door gasket not sealing properly • Inadequate air circulation due to product over loading • Evaporator coil is iced up or dirty

SERVICE: Please contact your local authorized service agent.

WIRING DIAGRAM(RB-SC) SELF-CONTAINED

WIRING DIAGRAM-MONTAGUE SELF-CONTAINED REFRIGERATED BASES

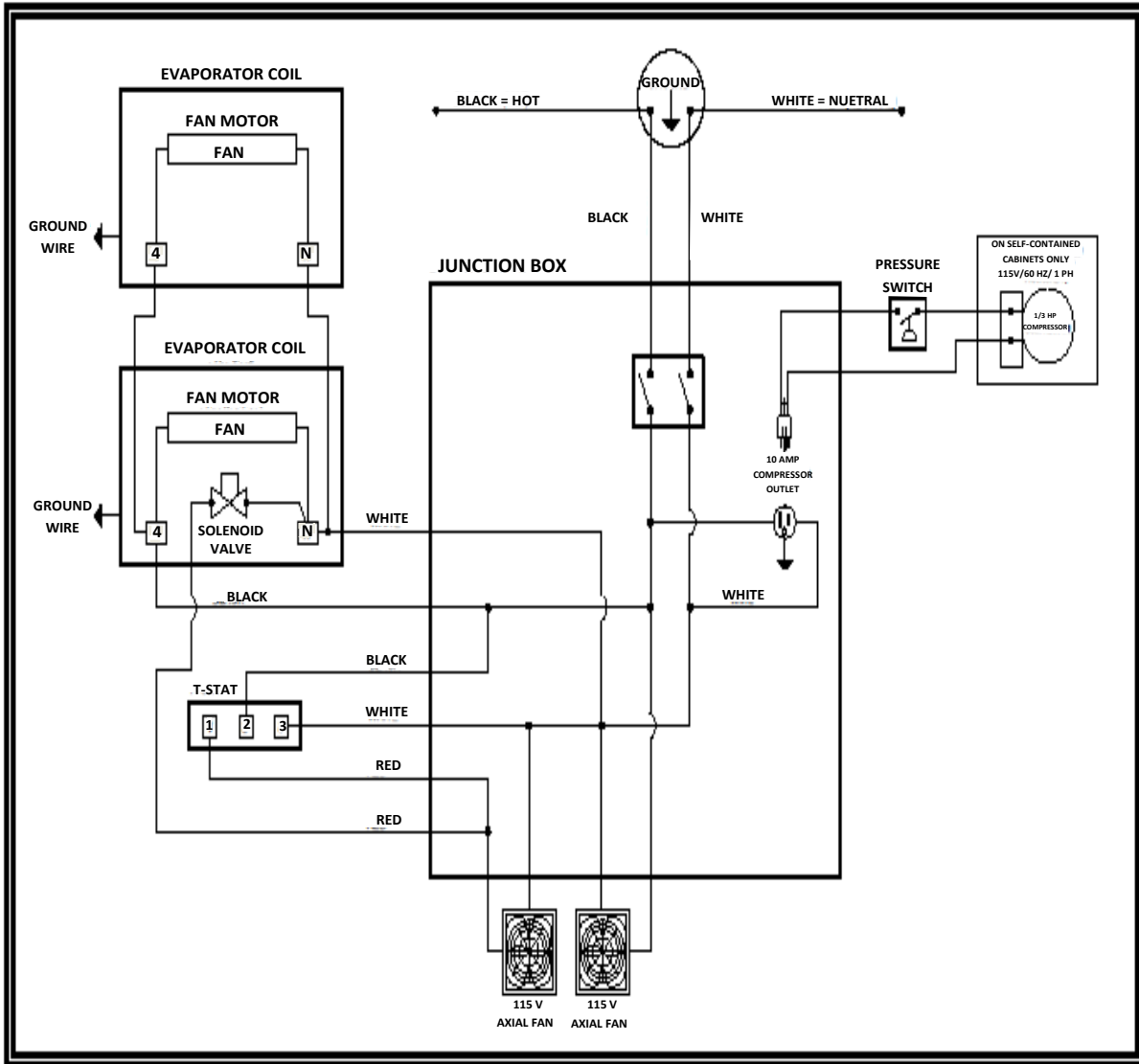

WIRING DIAGRAM(RB-R) REMOTE

WIRING DIAGRAM-MONTAGUE REMOTE REFRIGERATED BASES

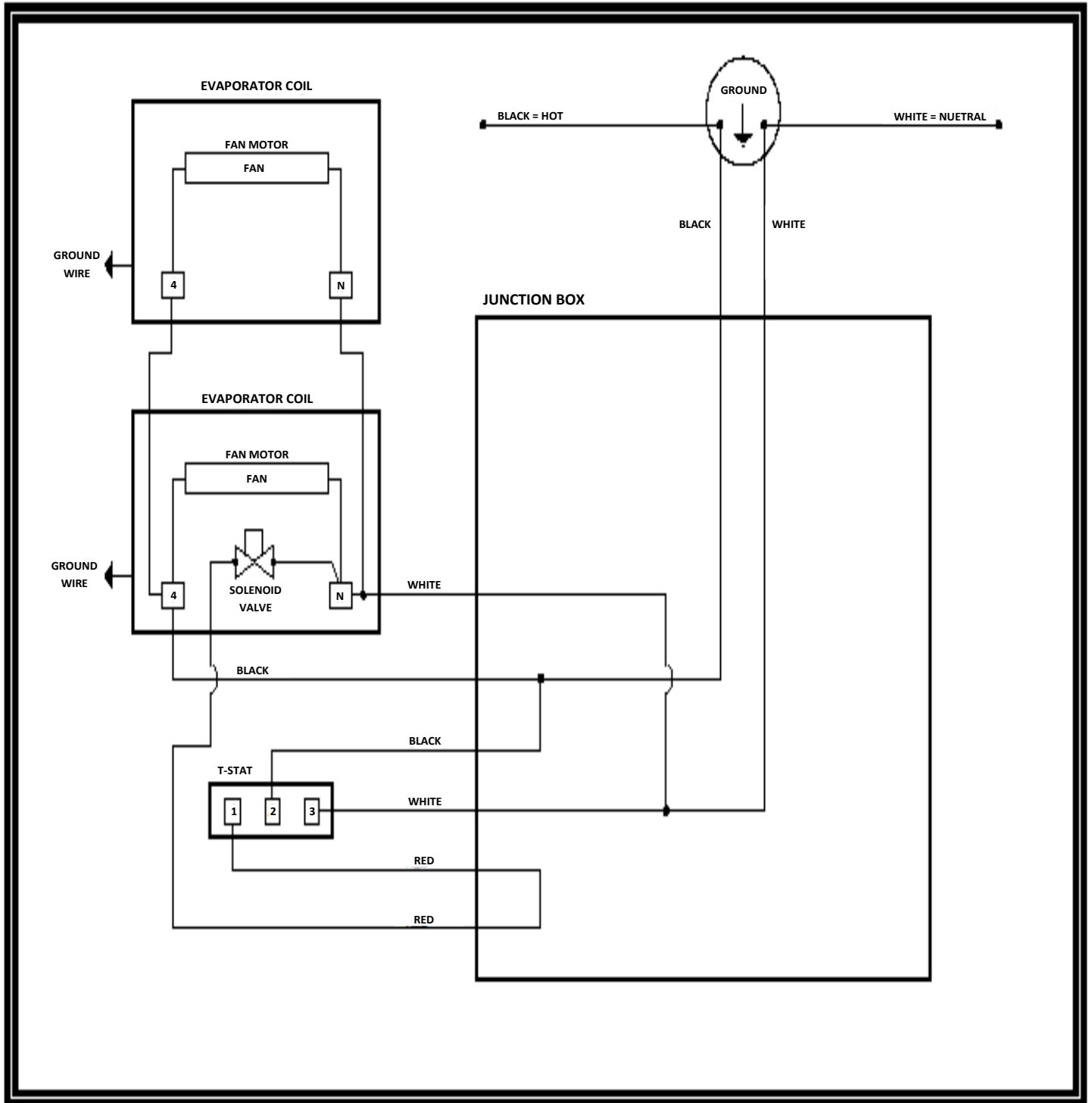

WIRING DIAGRAM(FB-SC) FREEZER

WIRING DIAGRAM-MONTAGUE FREEZER BASES

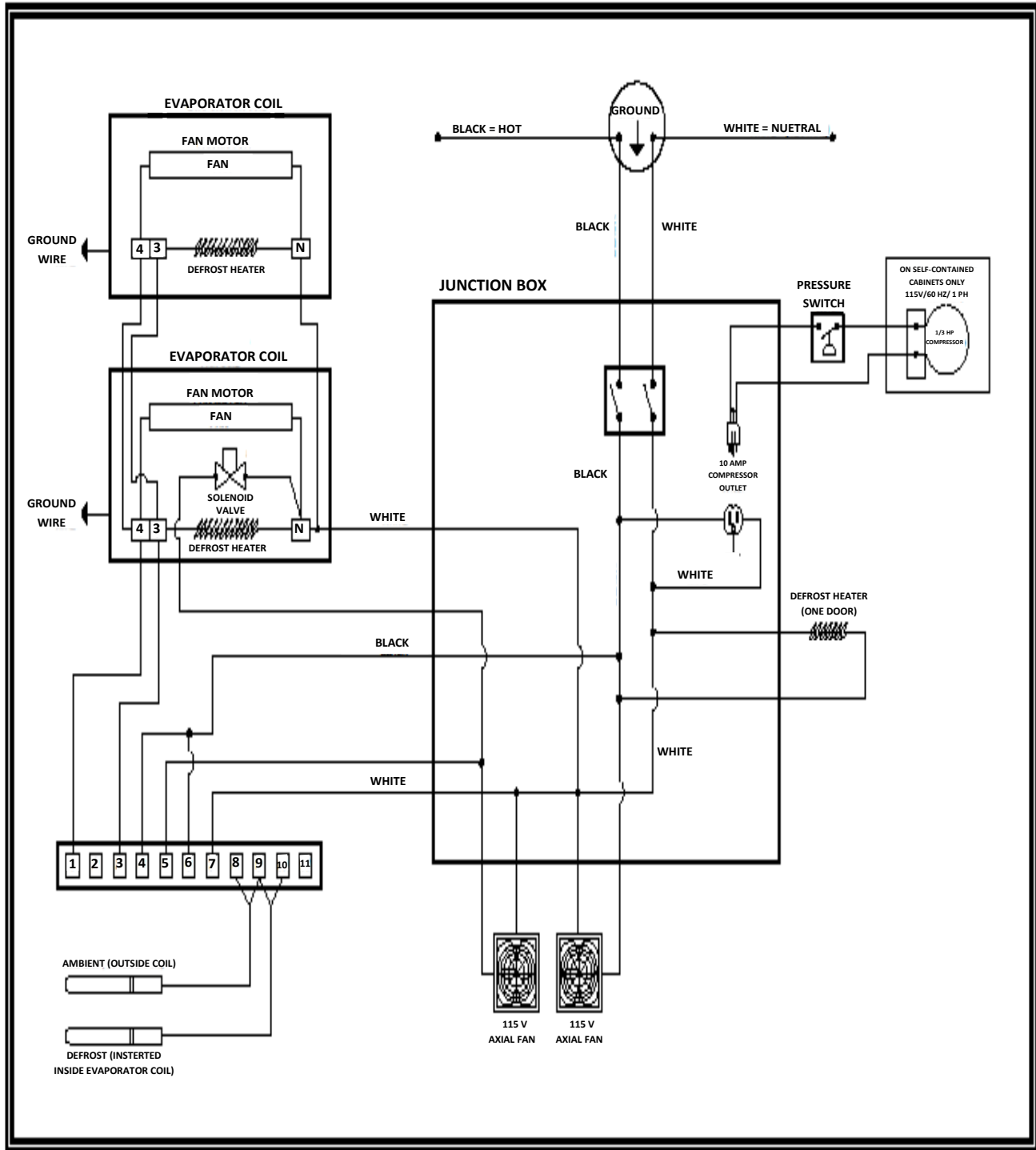

WIRING DIAGRAM(FB-R) FREEZER

WIRING DIAGRAM-MONTAGUE FREEZER BASES

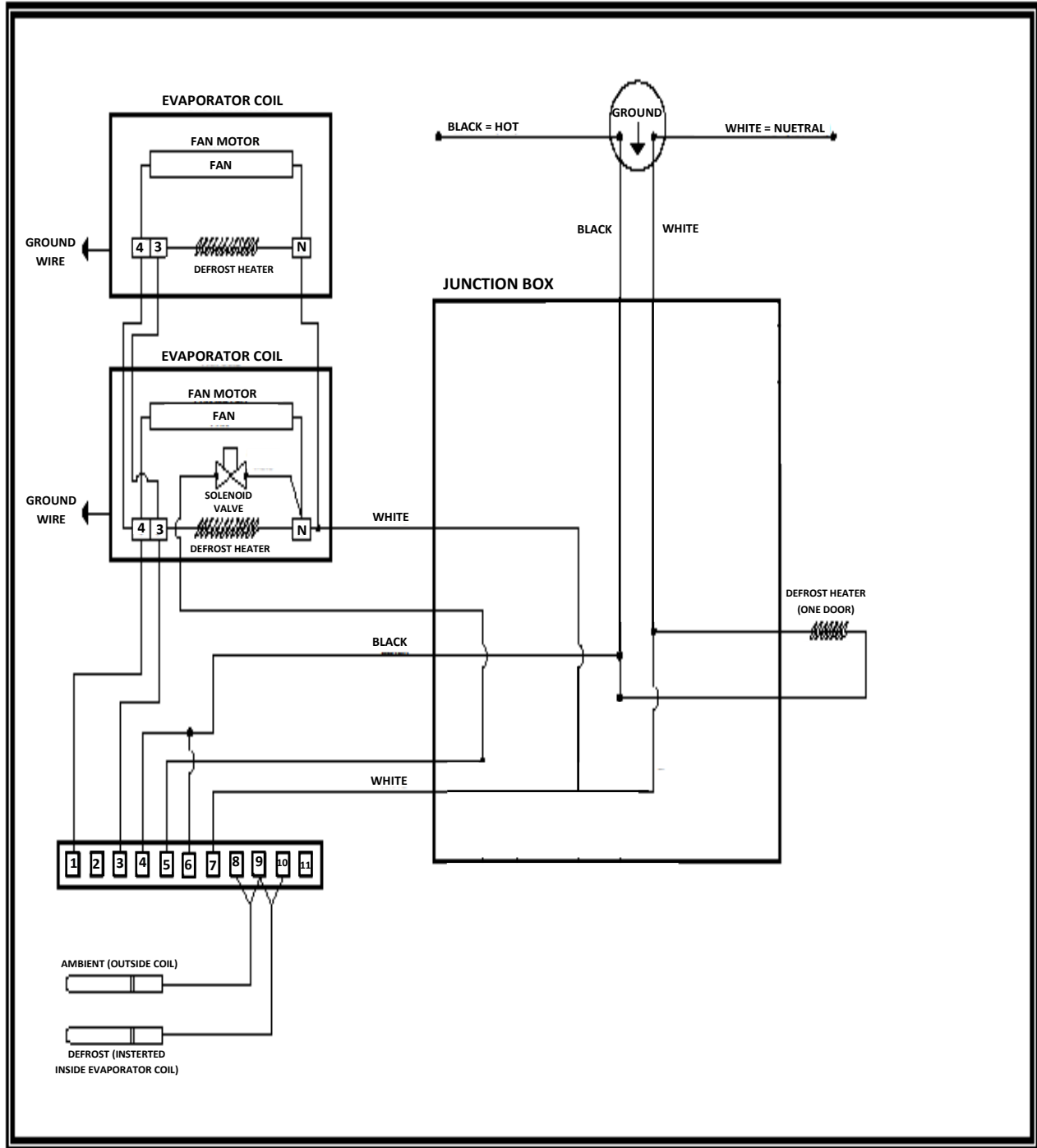

EXPLODED VIEW #1 PARTS LIST

ITEM #	PART #	DESCRIPTION	MODELS USED FOR
1	70030-4RA	FAN HOUSING	RB-36-SC, RB-48-SC, RB-60-SC, RB-72-SC, RB-84-SC, RB-96-SC, RB-108-SC
2	70031-2RA	CONDENSING GUARD	RB-36-SC, RB-48-SC, RB-60-SC, RB-72-SC, RB-84-SC, RB-96-SC, RB-108-SC
3	70032-0RA	CONDENSER SHELF	RB-36-SC, RB-48-SC, RB-60-SC, RB-72-SC, RB-84-SC, RB-96-SC, RB-108-SC
4	70044-4RA	CC BOTTOM SHELF	RB-36-SC, RB-48-SC, RB-60-SC, RB-72-SC, RB-84-SC, RB-96-SC, RB-108-SC
5	70045-2RA	CC EXTERIOR TOP	RB-36-SC, RB-48-SC, RB-60-SC, RB-72-SC, RB-84-SC, RB-96-SC, RB-108-SC
6	70046-0RA	CC EXTERIOR BOTTOM	RB-36-SC, RB-48-SC, RB-60-SC, RB-72-SC, RB-84-SC, RB-96-SC, RB-108-SC
7	70047-9RA	CC BOTTOM & TOP CHANNEL SUPPORT	RB-36-SC, RB-48-SC, RB-60-SC, RB-72-SC, RB-84-SC, RB-96-SC, RB-108-SC
8	70061-4RA	CC EXTERIOR, SIDE RIGHT	RB-36-SC, RB-48-SC, RB-60-SC, RB-72-SC, RB-84-SC, RB-96-SC, RB-108-SC
9	70084-2RA	CC EXTERIOR, INNER SIDE	RB-36-SC, RB-48-SC, RB-60-SC, RB-72-SC, RB-84-SC, RB-96-SC, RB-108-SC
10	70085-1RA	LOUVER, TOP RAIL	RB-36-SC, RB-48-SC, RB-60-SC, RB-72-SC, RB-84-SC, RB-96-SC, RB-108-SC
11	70087-8RA	LOUVER, PANEL	RB-36-SC, RB-48-SC, RB-60-SC, RB-72-SC, RB-84-SC, RB-96-SC, RB-108-SC
12	70148-3RA	INNER LOUVER, TOP RAIL	RB-36-SC, RB-48-SC, RB-60-SC, RB-72-SC, RB-84-SC, RB-96-SC, RB-108-SC
13	70190-4RA	CC SLIDING SHELF	RB-36-SC, RB-48-SC, RB-60-SC, RB-72-SC, RB-84-SC, RB-96-SC, RB-108-SC
14	70191-2RA	SHELF, SLIDER LEFT & RIGHT	RB-36-SC, RB-48-SC, RB-60-SC, RB-72-SC, RB-84-SC, RB-96-SC, RB-108-SC
15	70228-5RA	CC EXTERIOR, SIDE COVER	RB-36-SC, RB-48-SC, RB-60-SC, RB-72-SC, RB-84-SC, RB-96-SC, RB-108-SC
16	59682-5 59681-7	1/3 COMPRESSOR 1/3+ COMPRESSOR	RB-36-SC, RB-48-SC, RB-60-SC, RB-72-SC RB-84-SC, RB-96-SC, RB-108-SC
17	59667-1	AXIAL FAN, 4"	RB-36-SC, RB-48-SC, RB-60-SC, RB-72-SC, RB-84-SC, RB-96-SC, RB-108-SC
18	19118-3	CASTER WITH LOCK	RB-36-SC, RB-48-SC, RB-60-SC, RB-72-SC, RB-84-SC, RB-96-SC, RB-108-SC
19	19119-1	CASTER WITHOUT LOCK	RB-36-SC, RB-48-SC, RB-60-SC, RB-72-SC, RB-84-SC, RB-96-SC, RB-108-SC
20	33604-1	NUT SCREW	RB-36-SC, RB-48-SC, RB-60-SC, RB-72-SC, RB-84-SC, RB-96-SC, RB-108-SC

EXPLODED VIEW #2

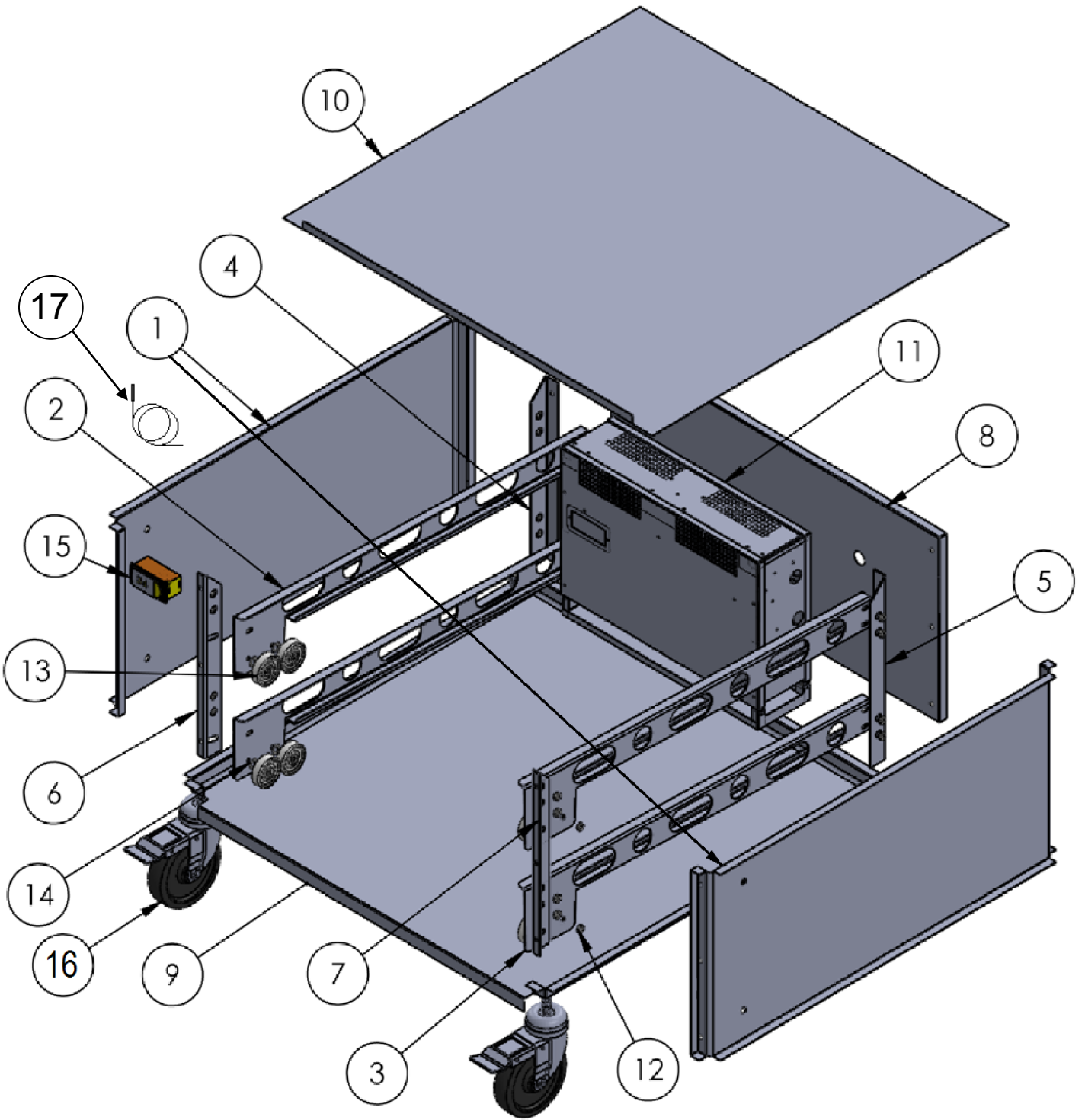

EXPLODED VIEW #2 PARTS LIST

ITEM #	PART #	DESCRIPTION	MODEL/S USED WITH
1	70002-9RA	LINER SIDE, LEFT & RIGHT	RB-36-R, RB-48-R, RB-60-R, RB-72-R, RB-84-R, RB-96-R, RB-108-R RB-36-SC, RB-48-SC, RB-60-SC, RB-72-SC, RB-84-SC, RB-96-SC, RB-108-SC
2	70023-1RA	DRAWER TRACK, LEFT	RB-36-R, RB-48-R, RB-60-R, RB-72-R, RB-84-R, RB-96-R, RB-108-R RB-36-SC, RB-48-SC, RB-60-SC, RB-72-SC, RB-84-SC, RB-96-SC, RB-108-SC
3	70025-8RA	DRAWER TRACK, RIGHT	RB-36-R, RB-48-R, RB-60-R, RB-72-R, RB-84-R, RB-96-R, RB-108-R RB-36-SC, RB-48-SC, RB-60-SC, RB-72-SC, RB-84-SC, RB-96-SC, RB-108-SC
4	70026-6RA	TRACK MOUNT, LEFT	RB-36-R, RB-48-R, RB-60-R, RB-72-R, RB-84-R, RB-96-R, RB-108-R RB-36-SC, RB-48-SC, RB-60-SC, RB-72-SC, RB-84-SC, RB-96-SC, RB-108-SC
5	70027-4RA	TRACK MOUNT, RIGHT	RB-36-R, RB-48-R, RB-60-R, RB-72-R, RB-84-R, RB-96-R, RB-108-R RB-36-SC, RB-48-SC, RB-60-SC, RB-72-SC, RB-84-SC, RB-96-SC, RB-108-SC
6	70028-2RA	TRACK MOUNT, FRONT LEFT	RB-36-R, RB-48-R, RB-60-R, RB-72-R, RB-84-R, RB-96-R, RB-108-R RB-36-SC, RB-48-SC, RB-60-SC, RB-72-SC, RB-84-SC, RB-96-SC, RB-108-SC
7	70029-0RA	TRACK MOUNT, FRONT RIGHT	RB-36-R, RB-48-R, RB-60-R, RB-72-R, RB-84-R, RB-96-R, RB-108-R RB-36-SC, RB-48-SC, RB-60-SC, RB-72-SC, RB-84-SC, RB-96-SC, RB-108-SC
8	70006-1RA 70111-4 70165-3RA 70268-4RA 70269-2RA 70270-6RA 70271-4RA 70483-0RA	LINER, BACK LINER, BACK LINER, BACK LINER, BACK LINER, BACK LINER, BACK LINER, BACK LINER, BACK	RB-36-SC RB-48-SC, RB-36-R RB-60-SC, RB-48-R RB-72-SC, RB-60-R RB-84-SC, RB-72-R RB-96-SC, RB-84-R RB-108-SC, RB-96-R RB-108-R
9	70009-6RA 70112-2 70155-6RA 70272-2RA 70273-0RA 70274-9RA 70275-7RA 70481-4RA	LINER, BOTTOM LINER, BOTTOM LINER, BOTTOM LINER, BOTTOM LINER, BOTTOM LINER, BOTTOM LINER, BOTTOM LINER, BOTTOM	RB-36-SC RB-48-SC, RB-36-R RB-60-SC, RB-48-R RB-72-SC, RB-60-R RB-84-SC, RB-72-R RB-96-SC, RB-84-R RB-108-SC, RB-96-R RB-108-R
10	70012-6RA 70113-0 70156-4RA 70276-5RA 70277-3RA 70278-1RA 70280-3RA 70482-2RA	LINER, TOP LINER, TOP LINER, TOP LINER, TOP LINER, TOP LINER, TOP LINER, TOP LINER, TOP	RB-36-SC RB-48-SC, RB-36-R RB-60-SC, RB-48-R RB-72-SC, RB-60-R RB-84-SC, RB-72-R RB-96-SC, RB-84-R RB-108-SC, RB-96-R RB-108-R

PARTS LIST CONTINUED ON NEXT PAGE

EXPLODED VIEW #2 PARTS LIST CONTINUED

11		TURBO COIL	SEE "ADDITIONAL INFORMATION" TABLE FOR DETAILS
12	59676-0	HEX JAM NUT	RB-36-R, RB-48-R, RB-60-R, RB-72-R, RB-84-R, RB-96-R, RB-108-R RB-36-SC, RB-48-SC, RB-60-SC, RB-72-SC, RB-84-SC, RB-96-SC, RB-108-SC
13	59630-2	SKATE WHEEL	RB-36-R, RB-48-R, RB-60-R, RB-72-R, RB-84-R, RB-96-R, RB-108-R RB-36-SC, RB-48-SC, RB-60-SC, RB-72-SC, RB-84-SC, RB-96-SC, RB-108-SC
14	59675-2	SPACER	RB-36-R, RB-48-R, RB-60-R, RB-72-R, RB-84-R, RB-96-R, RB-108-R RB-36-SC, RB-48-SC, RB-60-SC, RB-72-SC, RB-84-SC, RB-96-SC, RB-108-SC
15	59683-3	DIGITAL THERMOSTAT	RB-36-R, RB-48-R, RB-60-R, RB-72-R, RB-84-R, RB-96-R, RB-108-R RB-36-SC, RB-48-SC, RB-60-SC, RB-72-SC, RB-84-SC, RB-96-SC, RB-108-SC
16	19118-3	CASTER WITH LOCK	RB-36-R, RB-48-R, RB-60-R, RB-72-R, RB-84-R, RB-96-R, RB-108-R RB-36-SC, RB-48-SC, RB-60-SC, RB-72-SC, RB-84-SC, RB-96-SC, RB-108-SC
17	60516-6	DIGITAL THERMOSTAT TEMPERATURE PROBE	RB-36-R, RB-48-R, RB-60-R, RB-72-R, RB-84-R, RB-96-R, RB-108-R RB-36-SC, RB-48-SC, RB-60-SC, RB-72-SC, RB-84-SC, RB-96-SC, RB-108-SC

ADDITIONAL INFORMATION

ITEM #	PART #	DESCRIPTION	MODEL/S USED WITH
11	59690-6	TC-800 SLAVE, TXV ONLY	RB-48-R, RB-60-SC
11	59694-9	TC-1200 SLAVE, TXV ONLY	RB-60-R, RB-72-SC, RB-72-R, RB-84-SC, RB-84-R, RB-96-SC, RB-96-R, RB-108-SC, RB-108-R
11	59693-0	TC-1200 HALF-PREP, TXV, SOLENOID VALVE, SOLENOID COIL, NO T-STAT	RB-36-SC, RB-36-R, RB-48-SC
*11	59692-2	TC-1200 MASTER HALF-PREP, TXV, SOLENOID VALVE, SOLENOID COIL, NO T-STAT, EXTRA 1/4" LIQUID LINE TO FEED ADDITIONAL SLAVE COIL/S	RB-48-R, RB-60-SC, RB-60-R, RB-72-SC, RB-72-R, RB-84-SC, RB-84-R RB-96-SC, RB-96-R, RB-108-SC, RB-108-R

* PART # 59692-2 IS LOCATED IN ALL NOTATED MODELS. WHEN LOOKING AT THE FRONT OF THE UNIT, IT IS THE EVAPORATOR COIL LOCATED ON THE FURTHEST RIGHT HAND SIDE.

EXPLODED VIEW #3 PARTS LIST

ITEM #	PART #	DESCRIPTION	MODELS USED FOR
1	70014-2RA	DRAWER SLIDE RIGHT	RB-36-R,RB-48-R,RB-60-R,RB-72-R,RB-84-R,RB-96-R,RB-108-R RB-36-SC,RB-48-SC,RB-60-SC,RB-72-SC,RB-84-SC,RB-96-SC,RB-108-SC
2	70015-0RA	DRAWER SLIDE LEFT	RB-36-R,RB-48-R,RB-60-R,RB-72-R,RB-84-R,RB-96-R,RB-108-R RB-36-SC,RB-48-SC,RB-60-SC,RB-72-SC,RB-84-SC,RB-96-SC,RB-108-SC
3	70018-5RA	DRAWER STOP	RB-36-R,RB-48-R,RB-60-R,RB-72-R,RB-84-R,RB-96-R,RB-108-R RB-36-SC,RB-48-SC,RB-60-SC,RB-72-SC,RB-84-SC,RB-96-SC,RB-108-SC
4	70022-3RA	HANDLE ENDS	RB-36-R,RB-48-R,RB-60-R,RB-72-R,RB-84-R,RB-96-R,RB-108-R RB-36-SC,RB-48-SC,RB-60-SC,RB-72-SC,RB-84-SC,RB-96-SC,RB-108-SC
5	70042-8RA	PAN DIVIDER	RB-36-R,RB-48-R,RB-60-R,RB-72-R,RB-84-R,RB-96-R,RB-108-R RB-48-SC,RB-60-SC,RB-72-SC,RB-84-SC,RB-96-SC,RB-108-SC
6	70020-7RA	DRAWER FACE	RB-48-R,RB-36-SC,RB-60-SC
	70160-2RA	DRAWER FACE	RB-48-R,RB-60-R,RB-84-R,RB-108-R,RB-60-SC,RB-72-SC,RB-96-SC
	70106-8RA	DRAWER FACE	RB-36-R,RB-60-R,RB-72-R,RB-84-R,RB-96-R,RB-108-R RB-48-SC,RB-72-SC,RB-84-SC,RB-96-SC,RB-108-SC
7	70021-5RA	DRAWER HANDLE	RB-48-R,RB-36-SC,RB-60-SC
	70107-6RA	DRAWER HANDLE	RB-36-R,RB-48-R,RB-60-R,RB-72-R,RB-84-R,RB-96-R,RB-108-R RB-48-SC,RB-60-SC,RB-72-SC,RB-84-SC,RB-96-SC,RB-108-SC
8	70199-8RA	BACK COVER(BOTTOM DRAWER)	RB-48-R,RB-36-SC,RB-60-SC
	70019-3RA	BACK COVER(TOP DRAWER)	RB-48-R,RB-36-SC,RB-60-SC
	70161-0RA	BACK COVER(BOTTOM DRAWER)	RB-48-R,RB-60-R,RB-84-R,RB-108-R,RB-60-SC,RB-72-SC,RB-96-SC
	70162-9RA	BACK COVER(TOP DRAWER)	RB-48-R,RB-60-R,RB-84-R,RB-108-R,RB-60-SC,RB-72-SC,RB-96-SC
	70108-4RA	BACK COVER(BOTTOM DRAWER)	RB-36-R,RB-60-R,RB-72-R,RB-84-R,RB-96-R,RB-108-R RB-48-SC,RB-72-SC,RB-84-SC,RB-96-SC,RB-108-SC
	70110-6RA	BACK COVER(TOP DRAWER)	RB-36-R,RB-60-R,RB-72-R,RB-84-R,RB-96-R,RB-108-R RB-48-SC,RB-72-SC,RB-84-SC,RB-96-SC,RB-108-SC

PARTS LIST CONTINUED ON NEXT PAGE

EXPLODED VIEW PARTS LIST #3 CONTINUED

9	70016-9RA	PAN BACK DIVIDER	RB-48-R, RB-36-SC, RB-60-SC
	70164-5RA	PAN BACK DIVIDER	RB-48-R, RB-60-R, RB-84-R, RB-108-R, RB-60-SC, RB-72-SC, RB-96-SC
	70114-9RA	PAN BACK DIVIDER	RB-36-R, RB-60-R, RB-72-R, RB-84-R, RB-96-R, RB-108-R RB-48-SC, RB-72-SC, RB-84-SC, RB-96-SC, RB-108-SC
10	70017-7RA	PAN FRONT DIVIDER	RB-48-R, RB-36-SC, RB-60-SC
	70163-7RA	PAN FRONT DIVIDER	RB-48-R, RB-60-R, RB-84-R, RB-108-R, RB-60-SC, RB-72-SC, RB-96-SC
	70115-7RA	PAN FRONT DIVIDER	RB-36-R, RB-60-R, RB-72-R, RB-84-R, RB-96-R, RB-108-R RB-48-SC, RB-72-SC, RB-84-SC, RB-96-SC, RB-108-SC
11	70200-5RA	DRAWER SUPPORT	RB-36-R, RB-48-R, RB-60-R, RB-72-R, RB-84-R, RB-96-R, RB-108-R RB-36-SC, RB-48-SC, RB-60-SC, RB-72-SC, RB-84-SC, RB-96-SC, RB-108-SC
12	59630-2	SKATE WHEEL	RB-36-R, RB-48-R, RB-60-R, RB-72-R, RB-84-R, RB-96-R, RB-108-R RB-36-SC, RB-48-SC, RB-60-SC, RB-72-SC, RB-84-SC, RB-96-SC, RB-108-SC
13	59675-2	SPACER	RB-36-R, RB-48-R, RB-60-R, RB-72-R, RB-84-R, RB-96-R, RB-108-R RB-36-SC, RB-48-SC, RB-60-SC, RB-72-SC, RB-84-SC, RB-96-SC, RB-108-SC
14	60784-3	TOP DRAWER GASKET WITH SWEEP GASKET, 15.875" x 9.125"	RB-48-R, RB-36-SC, RB-60-SC
	60783-5	BOTTOM DRAWER GASKET, NO SWEEP GASKET, 15.875" x 9.125"	RB-48-R, RB-36-SC, RB-60-SC
	60785-1	TOP DRAWER GASKET WITH SWEEP GASKET, 23.875" x 9.125"	RB-48-R, RB-60-R, RB-84-R, RB-108-R, RB-60-SC, RB-72-SC, RB-96-SC
	60787-8	BOTTOM DRAWER GASKET, NO SWEEP GASKET, 23.875" x 9.125"	RB-48-R, RB-60-R, RB-84-R, RB-108-R, RB-60-SC, RB-72-SC, RB-96-SC
	60788-6	TOP DRAWER GASKET WITH SWEEP GASKET, 28.750" x 9.125"	RB-36-R, RB-60-R, RB-72-R, RB-84-R, RB-96-R, RB-108-R RB-48-SC, RB-72-SC, RB-84-SC, RB-96-SC, RB-108-SC
	60789-4	BOTTOM DRAWER GASKET, NO SWEEP GASKET, 28.750" x 9.125"	RB-36-R, RB-60-R, RB-72-R, RB-84-R, RB-96-R, RB-108-R RB-48-SC, RB-72-SC, RB-84-SC, RB-96-SC, RB-108-SC

EXPLODED VIEW #4

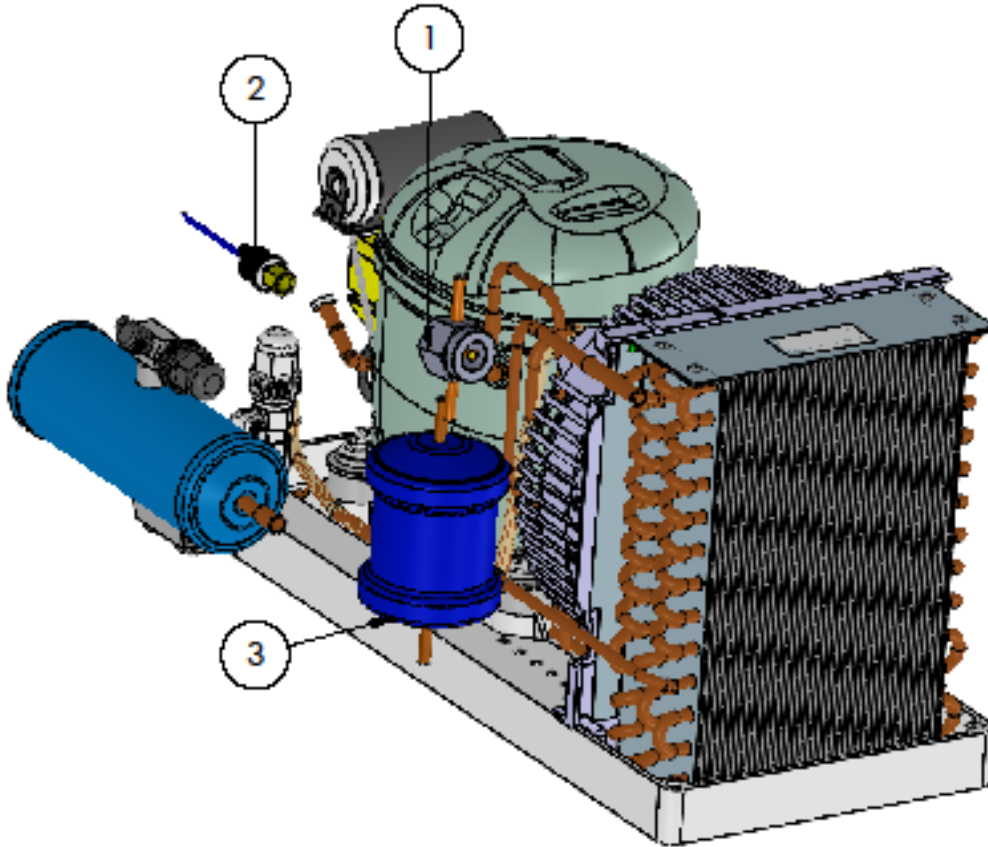

EXPLODED VIEW #4 PARTS LIST

ITEM #	PART #	DESCRIPTION	MODELS USED FOR
1	60513-1	SIGHT GLASS	RB-36-SC, RB-48-SC, RB-60-SC, RB-72-SC, RB-84-SC, RB-96-SC, RB-108-SC
2	60535-2	LOW PRESSURE SWITCH	RB-36-SC, RB-48-SC, RB-60-SC, RB-72-SC, RB-84-SC, RB-96-SC, RB-108-SC
3	60524-7	LIQUID LINE FILTER DRIER	RB-36-SC, RB-48-SC, RB-60-SC, RB-72-SC, RB-84-SC, RB-96-SC, RB-108-SC

IMPORTANT

When ordering part, to eliminate mistakes and facilitate delivery, always give the following information:

Serial No. _____

Model No. _____

Change No. _____

Name & No. of Part

Model No. Change No. Serial No.

--	--	--	--



The Montague Company
1830 Stearman Avenue
P.O. Box 4954
Hayward, CA 94540-4954



THE MONTAGUE COMPANY

1830 Stearman Avenue

P.O. BOX 4954

Hayward, CA 94540-4954

TEL: (510) 785-8822 FAX: (510) 785-3342

(Rev. A) P/N 61052-6