

# INSTRUCTION MANUAL

INSTALLATION / OPERATION / PARTS & SERVICE



# GAS FIRED SALAMANDER

**MODELS:  
SB36 & SB3618**

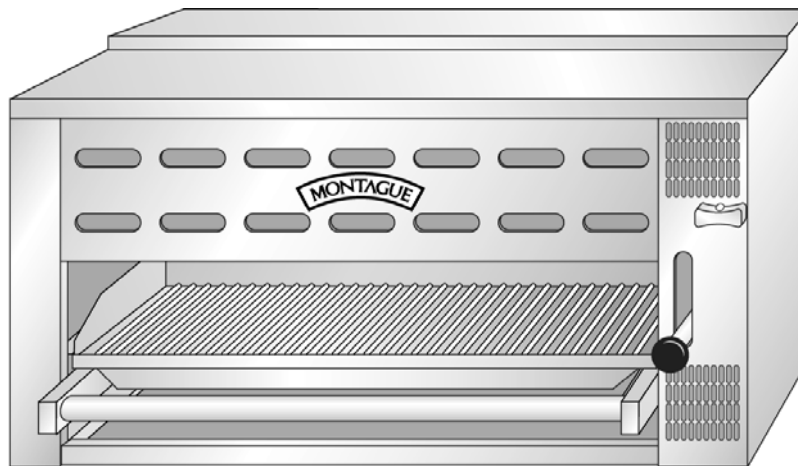

## NOTICE

**This manual is prepared for the use of Service Technicians and should not be used by those not properly qualified. This manual is not intended to be all encompassing. You should read, in its entirety, the repair procedure you wish to perform to determine if you have the necessary tools, instruments and skills required to perform the procedure.**

**RETAIN THIS MANUAL FOR FUTURE REFERENCE.**

## The MONTAGUE Company

1830 Stearman Ave. • P.O. Box 4954 • Hayward, CA 94540-4954

Tel: 510/785-8822

Fax: 510/786-9931

1-888-875-2722

WWW.MONTAGUECOMPANY.COM

# **IMPORTANT FOR YOUR SAFETY**

---

**THIS MANUAL HAS BEEN PREPARED FOR PERSONNEL QUALIFIED TO INSTALL GAS EQUIPMENT, WHO SHOULD PERFORM THE INITIAL FIELD START-UP AND ADJUSTMENTS OF THE EQUIPMENT COVERED BY THIS MANUAL.**

**POST IN A PROMINENT LOCATION THE INSTRUCTIONS TO BE FOLLOWED IN THE EVENT THE SMELL OF GAS IS DETECTED. THIS INFORMATION CAN BE OBTAINED FROM THE LOCAL GAS SUPPLIER.**

## **WARNING!**

**IN THE EVENT OF A POWER FAILURE,  
DO NOT ATTEMPT TO OPERATE THIS DEVICE.**

## **WARNING!**

**IN THE EVENT A GAS ODOR IS DETECTED, SHUT DOWN  
UNITS AT MAIN SHUTOFF VALVE AND CONTACT THE LOCAL GAS  
COMPANY OR GAS SUPPLIER FOR SERVICE**

## **FOR YOUR SAFETY!**

**DO NOT STORE OR USE GASOLINE OR OTHER  
FLAMMABLE VAPORS OR LIQUIDS IN THE VICINITY OF THIS  
OR ANY OTHER APPLIANCE.**

## **WARNING!**

***IMPROPER INSTALLATION, ADJUSTMENT, ALTERATION, SERVICE OR  
MAINTENANCE CAN CAUSE PROPERTY DAMAGE, INJURY, OR DEATH.***

***READ THE INSTALLATION, OPERATING, AND MAINTENANCE  
INSTRUCTIONS THOROUGHLY BEFORE INSTALLING, OPERATING OR  
SERVICING THIS EQUIPMENT.***

**SAVE THESE INSTRUCTIONS FOR FUTURE USE**

---

# TABLE OF CONTENTS

---

<b>NOTIFICATION</b> . . . . .	.1
<b>TABLE OF CONTENTS</b> . . . . .	.2
<b>INTRODUCTION</b> . . . . .	.3
<b>INSTALLATION</b> . . . . .	4
CLEARANCES & VENTILATION . . . . .	5
MOUNTING & LEVELING . . . . .	6
GAS CONNECTIONS . . . . .	7
GAS CONNECTION NOTICE . . . . .	8
<b>OPERATIONS</b> . . . . .	.9
OPERATING CONTROLS . . . . .	.9
GAS CONTROLS & GRID ADJUSTMENT . . . . .	9, 10
<b>CLEANING &amp; MAINTENANCE</b> . . . . .	.11
<b>SERVICE &amp; ADJUSTMENT PROCEDURES</b> . . . . .	12
COVERS & PANELS . . . . .	13
PILOT ADJUSTMENT & PILOT BURNER VALVE . . . . .	14
PILOT ORIFICE & MAIN BURNER VALVE . . . . .	15
MAIN BURNER ORIFICE . . . . .	16
TUBE & GEAR ASSEMBLY . . . . .	17
CARRIAGE FRAME HANDLE . . . . .	18
PRESSURE REGULATOR & PILOT BURNER . . . . .	19
PILOT VALVE, CARRIAGE ADJUSTMENTS. . . . .	20
<b>TROUBLE SHOOTING CHART</b> . . . . .	.21
<b>EXPLODED VIEW SB36</b> . . . . .	22
<b>PARTS LIST SB36</b> . . . . .	.23
<b>CARRIAGE STABILIZER COMPONENTS</b> . . . . .	.24
<b>3618 BURNER ASSEMBLY</b> . . . . .	25
<b>3618 MANIFOLD ASSEMBLY</b> . . . . .	26
<b>NOTES</b> . . . . .	27
<b>NOTICE</b> . . . . .	28
<b>BACK PAGE INSTRUCTIONS</b> . . . . .	29

# INTRODUCTION

## GENERAL

Montague Gas Salamander Broilers are manufactured for use with the type of gas indicated on the data plate (natural or propane).

### Installation

Refer to the Installation portion of this manual.

### Operation

Refer to the Operations portion of this manual.

### Cleaning

Refer to the Cleaning and Maintenance portion of this manual.

## SPECIFICATIONS

### Manifold Pressure:

Natural Gas: 6.0" W.C.

Propane Gas: 10.0" W.C.

**Orifices:** Fixed for specific gas type

Orifice Size:

Natural Gas: #41 (SB 36)

#33 (SB 3618)

Propane Gas: #51 (SB 36)

#48 (SB3618)

**Thermal Output:** 32,000 BTU (SB36)

42,000 BTU (SB3618)

**Gas Inlet Size:** 1/2" NPT at top right rear

(All Models)

## TOOLS

- Standard set of hand tools
- Gas leak detection equipment
- Gas pressure manometer

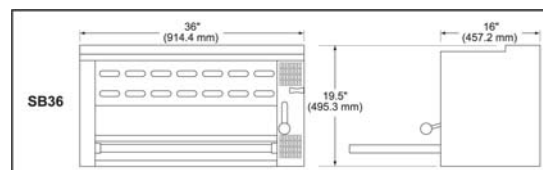

# INSTALLATION

---

The gas salamander broiler is manufactured for use with the type of gas indicated on the nameplate.

The Montague gas salamander broilers are produced with the best possible material and workmanship. PROPER INSTALLATION IS ESSENTIAL FOR SAFE AND EFFICIENT TROUBLE-FREE OPERATION.

THE INSTALLATION INSTRUCTIONS CONTAINED HEREIN ARE FOR THE USE OF QUALIFIED INSTALLATION AND SERVICE PERSONNEL ONLY. INSTALLATION OR SERVICE BY OTHER THAN QUALIFIED PERSONNEL MAY RESULT IN DAMAGE TO THE BROILER AND/OR INJURY TO THE OPERATOR.

Qualified installation personnel are individuals, a firm, corporation or company which either in person or through a representative are engaged in and are responsible for:

- A. The installation or replacement of gas piping or the connection, installation, repair or servicing of equipment, who is experienced in such work, familiar with all precautions required, and has complied with all requirements of state or local authorities having jurisdiction. Reference National Fuel Gas Code Z223.1, latest addendums.
- B. The installation of electrical wiring from the electrical meter, main control box or service outlet to the electric appliance. Qualified installation personnel must be experience and licensed in such work, be familiar with all precautions required and have complied with all requirements of state or local authorities having jurisdiction. Reference; National Electric Code N.F.P.A. No. 70 including all latest addendums.

## CAREFULLY READ AND FOLLOW THESE INSTRUCTIONS

THE BROILER(S) MUST BE INSTALLED IN ACCORDANCE WITH ALL LOCAL CODES, OR IN THE ABSENCE OF LOCAL CODES, WITH THE NATIONAL FUEL GAS CODE, ANSI Z223.1, LATEST ADDENDUM INCLUDING:

- 1. The appliance and its individual shutoff valve be disconnected from the gas supply piping system during any pressure testing of that system at test pressures in excess of 1/2 psig (3.45kPa).
- 2. The appliance must be isolated from the gas supply piping system by closing its individual manual and or automatic shut off valves during any pressure testing of the gas supply piping system at pressures equal to or less than 1/2 psig (3.45 kPa).

# INSTALLATION



## CAUTION

Provisions must be made to assure adequate air supply to unit for proper burner operation.

*NOTE:* Remove all packing material and plastic coating before installing unit.

## CLEARANCES

The following is the minimum clearance from combustible material and noncombustible material.

**NOTE:** For use only in noncombustible locations.

LOCATION	DESCRIPTION
<b>Counter Installation</b>	For installation on noncombustible counter adjacent to noncombustible walls.
<b>Wall Mounted</b>	Mounted on noncombustible wall with 18" clearance from side and bottom to combustible material.
<b>Range Mounted</b>	Refer to data plate mounted on the range for proper clearance.

## VENTILATING HOOD

The broiler(s) must be installed under a properly designed ventilating hood. The hood should extend at least 6" beyond all sides of the unit. The hood should be connected to an approved mechanical exhaust system which meets all necessary exhaust requirements and local codes.

Information on construction and installation of ventilating hoods may be obtained from the "Standard for the Installation of Equipment for the Removal of Smoke and Grease Laden Vapors No. 96 - available from the National Fire Protection Association Batterymarch Park, Quincy, Ma. 02269.

It is also necessary that sufficient room air ingress be allowed to compensate for the amount of air removed by the ventilating system. Otherwise, a subnormal atmospheric pressure will occur which may interfere with burner performance or may extinguish the pilot flame. In case of unsatisfactory broiler performance, check unit with exhaust system off to eliminate ventilation as a possible cause of the problem.

## LOCATION

Adequate clearance for service and proper operation must be provided at the front, top, sides and back. The combustion air openings are provided in the front of the unit, flue area on top and bottom and must not be obstructed.

## Counter Installation

Unit must be installed level. Place shims under low side to level the unit.

## Wall Mounted



## CAUTION

Mount on a noncombustible wall only.

Wall mounted units must be installed on a noncombustible wall.

**NOTE:** Wall must be strong enough to hold weight of salamander.

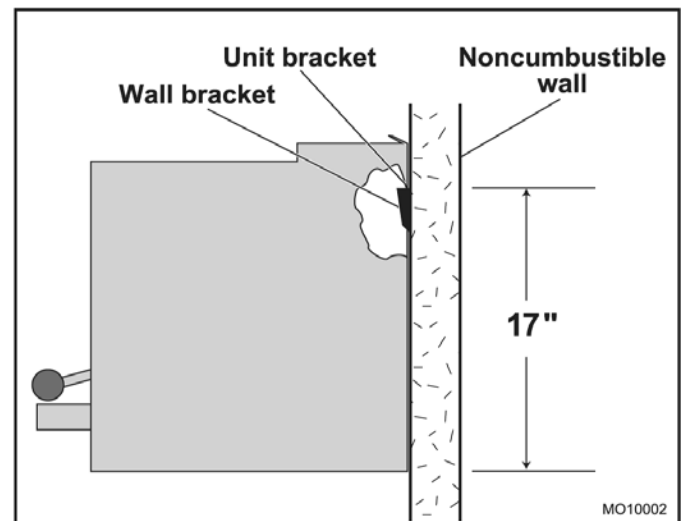

# INSTALLATION

1. Remove lower bracket from back of salamander broiler.
2. Attach bracket securely to the wall at the required height and location. Be sure bracket is mounted level.
3. Place unit so that the broiler-mounted bracket engages the wall bracket.
4. Check that unit is level.

## Range Mounted

### MODEL SB36 TECHNOSTAR

Unit must be mounted on a reinforced high shelf on any 36" wide Model T26, VT26, T260, T2616, T1626 series Montague Technostar range as follows:

1. Lift the reinforced high back above the range and slide channels into position on the range body.
2. Secure with self tapping screws through the holes that are provided in the range body.
3. Lift salamander broiler over the flue outlet of high back and set unit in place on shelf.
4. Align holes in high back with holes in bottom of broiler.
5. Secure broiler to high back using four (4) 1/4-20x3/4 cap screws and washers which are provided.
6. Attach the bottom cover panel to the underside of the broiler using the two (2) screws that are provided. The bottom cover panel should cover the underside of the broiler from the front of the unit to the front edge of the shelf.
7. Check that appliance is level.

### Model SB36

May be mounted on 36" high shelf as instructed above or mounted on a custom reinforced high back for installation on any Model 136, V136 or 36 series Montague range as follows:

Lift the salamander broiler assembly above the range and slide the channels into position on the range body.

FLUE BASE ACCEPTS  
HIGH BACK POSTS

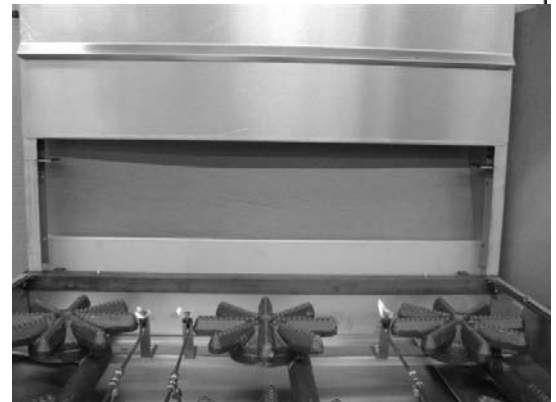
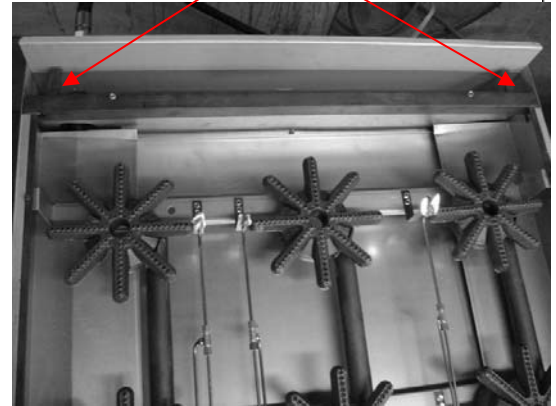

## LEVELING

After appliance is mounted, check that appliance is level both side-to-side and front-to-back.

# INSTALLATION

## GAS PRESSURE REGULATOR

### **WARNING**

**THIS BROILER IS DESIGNED FOR USE WITH A GAS PRESSURE REGULATOR. THE REGULATOR SUPPLIED WITH THIS UNIT MUST BE USED.**

**FOR NATURAL GAS:** This gas pressure regulator is factory adjusted for 6.0" W.C. (water column) manifold pressure. Rated inlet pressure to the regulator is 1/2 psig (3.45 kPa).

**FOR PROPANE GAS:** This gas pressure regulator is factory adjusted for 10" W.C. manifold pressure. The rated inlet pressure to the regulator is 1/2 psig (3.45 kPa).

The broiler is equipped with fixed orifices for use with a manifold pressure of 6.0" W.C. for natural gas and 10.0" W.C. for propane gas.

Locate the gas pressure regulator external to the salamander broiler as near the unit as possible. The gas pressure regulator must be located out of the heat zone to prevent damage to the regulator.

## EXTERNAL GAS SHUTOFF VALVE

Codes require that a gas shutoff valve be installed in the gas line ahead of the broiler.

## GAS CONNECTION

Before connecting the broiler to the gas supply line, be sure that all new piping has been cleaned and purged to prevent any foreign matter from being carried into the controls by the gas. In some cases, filters or drops are recommended. A separate gas shutoff valve must be installed upstream from the gas pressure regulator adjacent to the broiler and located in an accessible area.

It is important that adequately sized piping be run directly to the point of connection at the broiler with as few elbows and tees as possible. Consult local gas codes for proper piping size and gas pressure.

**NOTE:** Pipe joint compound or thread sealant that is used should be resistant to action of liquified petroleum gases.

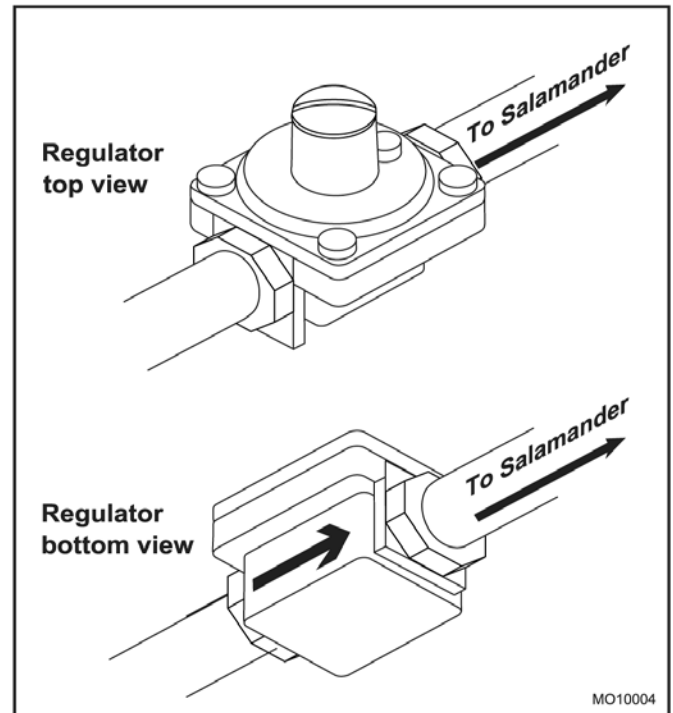

Install the gas pressure regulator with gas flowing as indicated by the arrow on the regulator. The arrow must be pointing in toward the unit. Use pipe compound or thread sealant and carefully thread regulator to pipe so that there is no cross threading, etc., which could cause leakage.

1. Apply wrench only to the flat areas around the pipe tapping at the end being threaded to the pipe and avoid overtightening to avoid possible damage to the regulator body which could result in leakage.
2. Connect the gas supply line from the service gas shutoff valve to the inlet side of the gas pressure regulator using 1/2" pipe. Avoid kinks or sharp bends that could restrict gas flow.

**NOTE:** If flexible or semi-flexible connectors are used, a commercial **CSA**-listed flexible connector with an I.D. equal to 1/2" pipe must be used.

### **WARNING**

**DO NOT USE A DOMESTIC TYPE GAS FLEXIBLE CONNECTOR.**

# INSTALLATION

---

3. Turn gas shutoff valve on and immediately carefully check for gas leaks. Do this before attempting to operate the salamander broiler.

 **WARNING**

**TEST ALL PIPE JOINTS FOR LEAKS BEFORE OPERATING SALAMANDER BROILER. THIS INCLUDES ALL GAS CONNECTIONS THAT MAY HAVE LOOSENED DURING SHIPMENT. USE A RICH SOAP SOLUTION (OR OTHER ACCEPTED LEAK TESTER) AROUND ALL PIPE CONNECTIONS AND ALL OTHER JOINTS. DO NOT USE AN OPEN FLAME. ABSOLUTELY NO LEAKAGE SHOULD OCCUR, OTHERWISE, THERE IS A DANGER OF FIRE OR EXPLOSION DEPENDING UPON CONDITIONS. DO NOT USE UNIT IF LEAKAGE IS DETECTED.**

 **WARNING**

**MAIN GAS VALVE TO UNIT MUST BE TURNED OFF WHEN DOING LINE PRESSURE TEST. DAMAGE TO COMPONENTS MAY RESULT IF VALVE IS NOT TURNED OFF.**

After piping has been checked for leaks, all piping receiving gas should be fully purged to remove air.

# OPERATIONS

This appliance has been classified as commercial cooking equipment and must be operated by qualified and/or professional operating personnel.

## **! WARNING**

**THE SALAMANDER AND ITS PARTS ARE HOT. USE CARE WHEN OPERATING, CLEANING OR SERVICING THE UNIT.**

## **! CAUTION**

*Do not obstruct the flow of combustion and ventilation air to the broiler. Keep the appliance area free and clear from combustibles. Keep flue area free from obstruction.*

## OPERATING CONTROLS

## **! WARNING**

**IN THE EVENT A GAS ODOR IS DETECTED, SHUT DOWN UNITS AT MAIN SHUTOFF VALVE AND CONTACT THE LOCAL GAS COMPANY OR GAS SUPPLIER FOR SERVICE.**

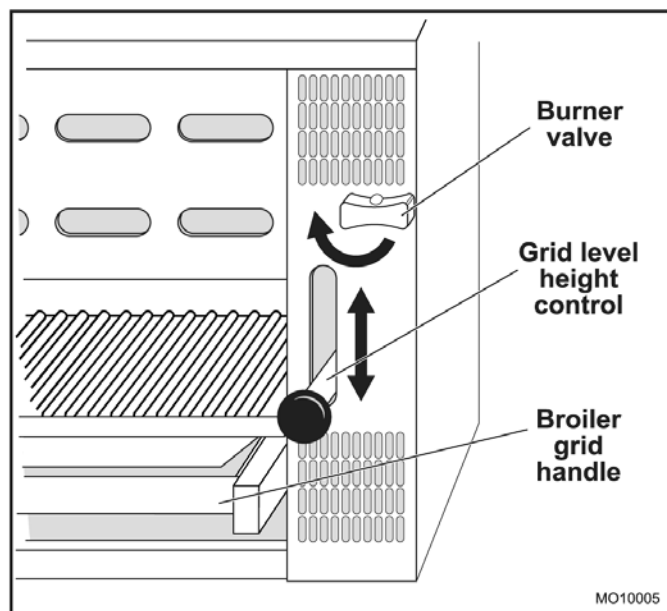

**GAS CONTROL** - Burner valve used to turn gas ON or OFF.

**GRID HEIGHT** - The grid is set to the desired cooking height by depressing the black ball and adjusting lever up or down.

**BROILER GRID HANDLE** - Moves the grid in or out for easy loading and unloading.

## GAS CONTROL

### Lighting/Relighting Pilot

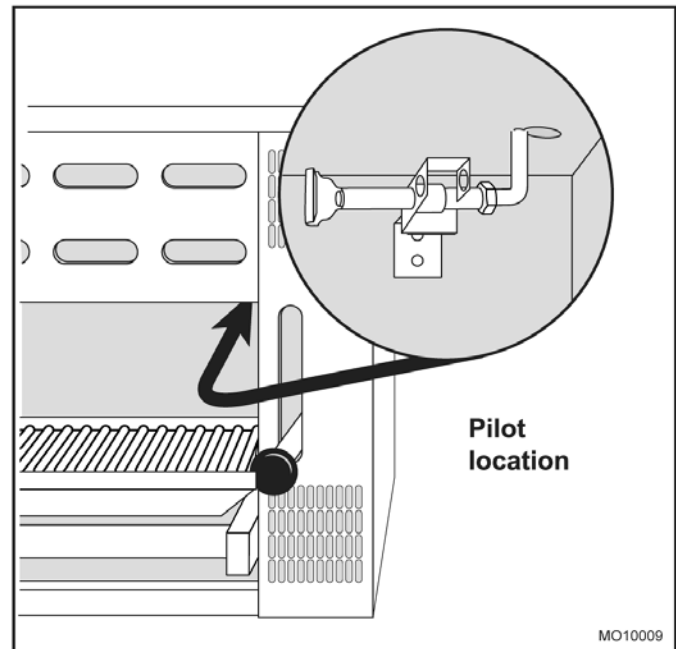

1. Turn Burner Valve handle to OFF position and wait five (5) minutes.
2. Apply lighted match to pilot burner and/or check that pilot is burning.
3. Rotate Burner Valve handle counter-clockwise to full ON. Burner will ignite automatically.
4. If pilot becomes extinguished, turn Burner Valve to the Off position and wait (5) minutes before relighting.

# OPERATIONS

---

## Shutdown

1. **Standby:** To turn off, rotate Burner Valve handle clockwise.
2. **Complete:** Turn main gas valve to OFF position.

**IMPORTANT: NEVER THROTTLE THE BURNER DOWN. OPERATE BURNER IN FULL "ON".**

**NOTE: Model SB3618 is manufactured with a throttling burner. Turn Main Burner Valve clockwise to close or adjust burner flame down or counter clockwise to open or adjust burner flame up.**

## Grid Height Adjustment

Depress the ball and move lever up or down to desired cooking height.

# CLEANING & MAINTENANCE

---

Montague equipment is sturdily constructed of the best materials and is designed to provide durable service when treated with ordinary care. To expect the best performance, your equipment must be maintained in good condition and cleaned daily.

Naturally, the periods for this care and cleaning depend on the amount and degree of usage.

*Following daily and periodic maintenance procedures will enhance long life for your equipment. Climatic conditions (such as salt air) may require more thorough and frequent cleaning or the life of the equipment could be adversely affected.*

Keep exposed, cleanable areas of unit clean at all times.

## **DAILY:**

- Remove, empty, and clean drippings collection drawer.
- Clean drippings drain chute.

## **MONTHLY:**

- Clean around burner air mixers and orifices if lint has accumulated.
- Visually assure proper pilot operation.

## **BROILERS:**

To prevent excess smoking, the grids, rack drip pan, and other broiler components must be kept clean of food remnants. Use a wire brush or similar scraping utensil.

**DO NOT** use steel wool or similar scrub pad that will leave small particles, which can get into food, The cleaning procedure is as follows:

1. Move the broiling rack to the low position. Pull out the rolling broiler rack.
2. Lift out the broiler grid and clean it with a wire brush or non-toxic solvent.
3. Remove the rack pan and clean.
4. With rolling rack pulled-out to its "stop", raise front handle so rack's rollers will come through the notches in the raising and lowering frame. Clean all parts where residue can collect.
5. clean all parts of the raising and lowering frame.
6. Clean entire hopper section of all caked grease and residue.
7. Lubricate bearings with cooking oil.
8. Reverse procedure to reassemble broiling rack mechanism.

# SERVICE & ADJUSTMENT PROCEDURES

---

## **WARNING**

WHEN SERVICE IS NEEDED, CONTACT A LOCAL SERVICE COMPANY, DEALER OR FACTORY TO PERFORM MECHANICAL MAINTENANCE AND REPAIRS. THESE INSTRUCTIONS ARE INTENDED FOR USE BY COMPETENT SERVICE PERSONNEL.

## **CAUTION**

TURN OFF GAS AT THE MANUAL OR AUTOMATIC SHUT OFF VALVE CONTROLLING THE APPLIANCE BEFORE ATTEMPTING TO LOOSEN ANY GAS CONNECTIONS.

**\*\*GAS PRESSURE REGULATOR\*\***

## **WARNING**

NO UNTRAINED PERSON SHOULD ATTEMPT TO MAINTAIN OR SERVICE THE GAS PRESSURE REGULATOR

# SERVICE & ADJUSTMENT PROCEDURES

Perform the following procedures to remove and install parts. To eliminate mistakes when ordering parts, always provide the following information:

- Serial Number
- Model Number
- Change Number

These numbers are located on the data plate.

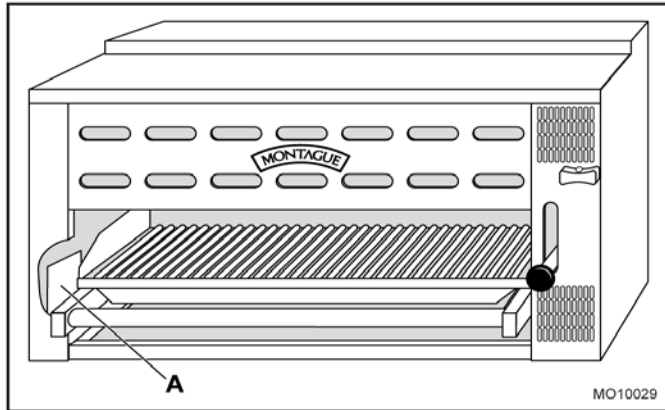

Location of Data Plate

A Data plate

1. Remove the screws that secure the panel to the cabinet.
2. Remove the panel off of the cabinet.
3. Reverse the above steps to replace the panel.

## Front Control Panel

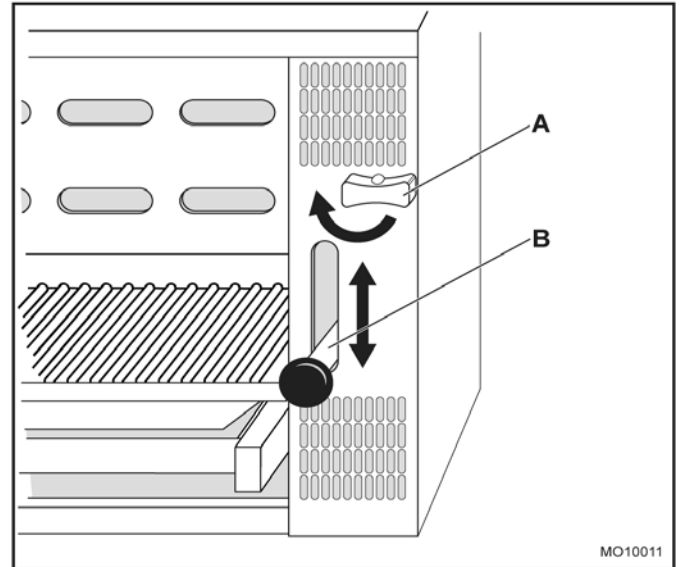

Front control panel

- A Main burner control knob
- B Carriage position handle

## COVERS AND PANELS

### Cabinet Top Panel

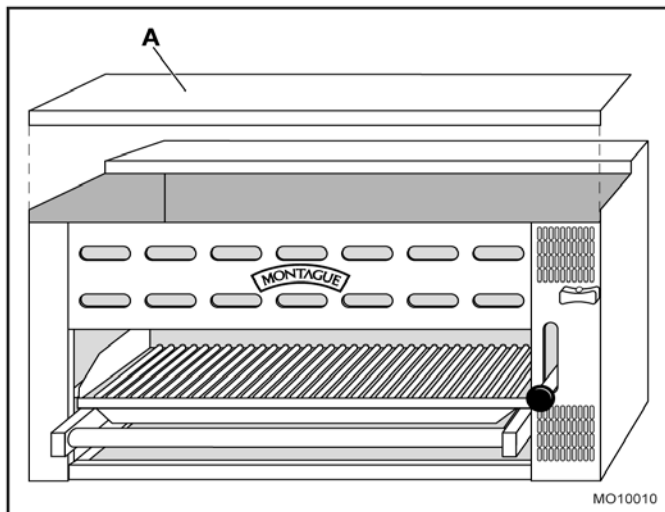

Cabinet top panel

A Top panel

1. Loosen the Set Screw on the chrome Main Burner Control Knob.
2. Remove the Main Burner Control Knob.
3. Remove the Black Ball Knob and Chrome Sleeve from the Carriage Position Handle.
4. Remove the two screws near the bottom of the panel.
5. Remove the panel from the cabinet.
6. Reverse the above steps to replace the panel.

# SERVICE & ADJUSTMENT PROCEDURES

## Cabinet Back Panel

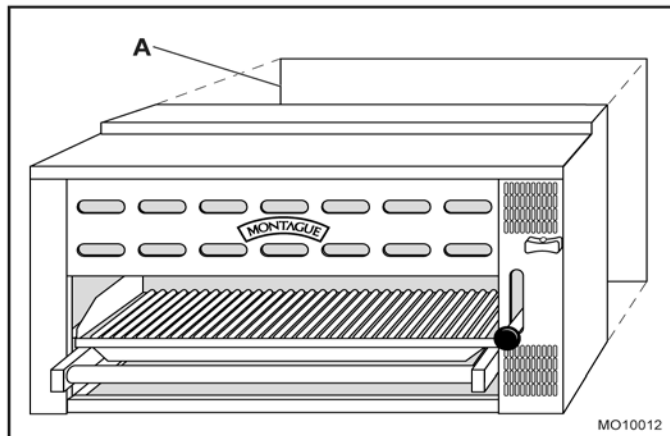

Cabinet back panel

### A Back panel

1. Remove the screws that secure the panel to the cabinet.
2. Remove the panel from the cabinet.
3. Reverse the above steps to reinstall the panel.

## PILOT ADJUSTMENT VALVE

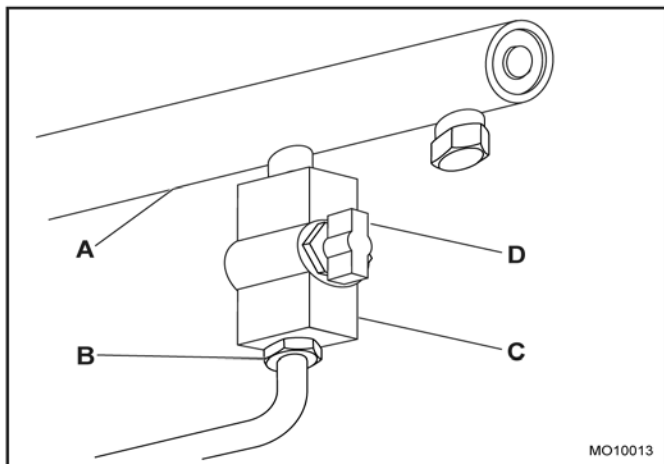

Pilot adjustment valve

- A Gas manifold
- B Nut
- C Pilot adjustment valve
- D Pilot adjustment knob

NOTE: Make sure that the pipe joint compound or pipe thread sealant that is being used is resistant to the corrosive actions of liquified petroleum gases.

1. Verify that the gas supply is off.
2. Remove the front control panel as outlined under COVERS AND PANELS.
3. Loosen the nut that holds the Pilot Burner gas line to the Pilot Adjustment Valve. Make sure the gas line is no longer connected to the Pilot Adjustment Valve.
4. Unscrew the Pilot Adjustment Valve from the Gas Manifold.
5. Reverse the above steps to replace the Pilot Adjustment Valve.

## PILOT BURNER

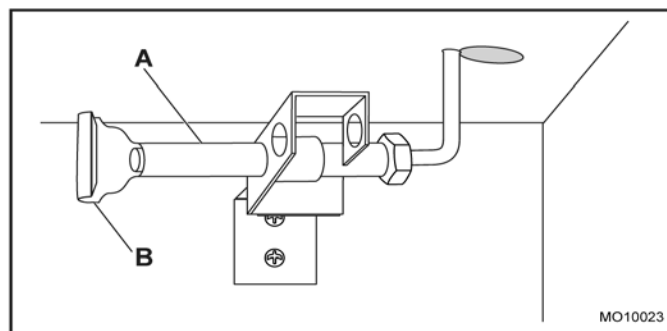

Pilot burner

- A Pilot burner
- B Flame shield

NOTE: Make sure that the pipe joint compound or pipe thread sealant that is being used is resistant to the corrosive actions of liquified petroleum gases.

1. Verify that the gas supply is off.
2. Turn off the Main Burner.
3. Allow the Salamander unit to cool to room temperature.
4. Loosen the hex nut end of the Pilot Burner that secures it to the gas line. Make sure that the Pilot Burner and gas line are completely separated.
5. Remove the two screws that secure the Pilot Burner Bracket to the back wall of the compartment.
6. To remove the Pilot Burner from its bracket, unscrew the Flame Shield from the Pilot Burner and slide the bracket off of the Pilot Burner.
7. Reverse the above steps to replace the Pilot Burner.

# SERVICE & ADJUSTMENT PROCEDURES

## PILOT BURNER ORIFICE

1. Perform Step 1 through Step 6 of the *Pilot Burner Removal and Replacement Procedure*.
2. Unscrew the Pilot Burner Orifice from the Pilot Burner.
3. Clean or replace the Orifice
4. Screw the new Orifice into the Pilot Burner.
5. Perform Step 1 through Step 6 of the *Pilot Burner Removal and Replacement Procedure* in reverse order to replace the Pilot Burner.

## MAIN BURNER GAS CONTROL VALVE KNOB

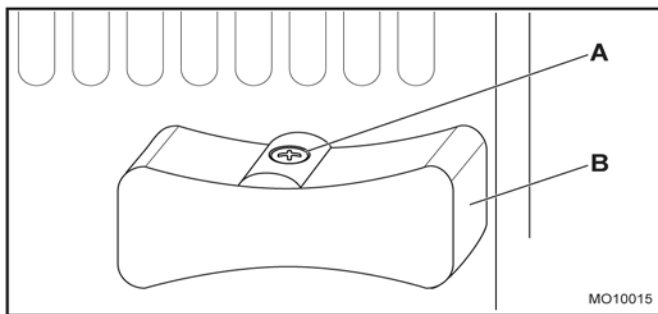

**Gas control valve knob**

**A Set screw**

**B Knob** ( ALLEN HEAD SET SCREW)

1. Loosen the Set Screw on the Gas Control Valve Knob.
2. Pull the knob off of the Gas Valve Shaft.
3. Reverse the above steps to replace the knob.

## MAIN BURNER GAS CONTROL VALVE

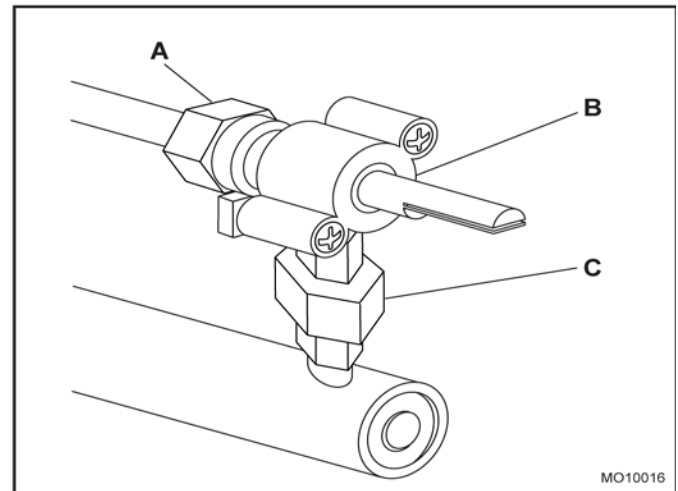

**Main burner gas control valve**

**A Nut**

**B Gas control valve**

**C Gas pipe union**

**NOTE:** Make sure that the pipe joint compound or pipe thread sealant that is being used is resistant to the corrosive actions of liquified petroleum gases.

1. Remove the Front Control Panel as outlined under **COVERS AND PANELS**.
2. Remove the Main Burner Gas Control Valve from the gas line to the Main Burner by loosening the hex nut located at the rear of the valve unit.
3. Remove the valve from the Gas Manifold by loosening the nut on the Gas Pipe Union.
4. Reverse the above steps to replace the Main Burner Gas Control Valve.

# SERVICE & ADJUSTMENT PROCEDURES

## SB 36

### MAIN BURNER ORIFICE

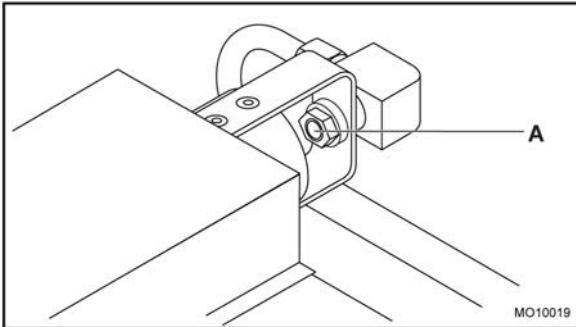

Main burner orifice

#### A Orifice

1. Perform Step 1 through Step 7 of the *Main Burner Removal and Replacement Procedure*.
2. Unscrew the Orifice from the 90 Degree Elbow Fitting.
3. Screw a new Orifice into the Elbow Fitting.
4. Perform the above steps in reverse order to reassemble the unit.

### CARRIAGE POSITION HANDLE

The Carriage Position Handle consists of the parts shown in the following illustration and list.

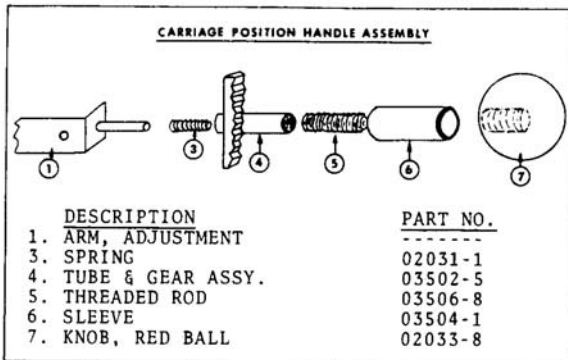

## SB 3618

### SB 3618 MAIN BURNER PARTS

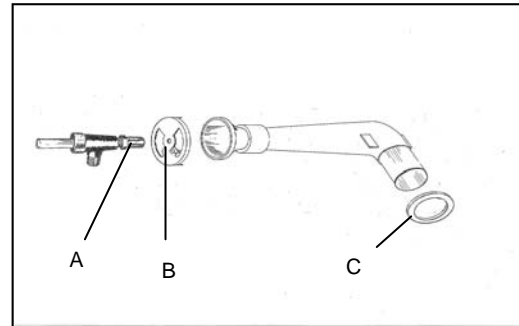

#### A. Main burner orifice

Unscrew orifice from valve to remove debris. Replace if needed.

#### B. Air Shutter

Clean shutter opening of lint and debris. Adjust shutter open or closed until desired flame is achieved.

#### C. Gasket

Replace burner gasket each time burner is serviced.

## SB 3618 CERAMICS

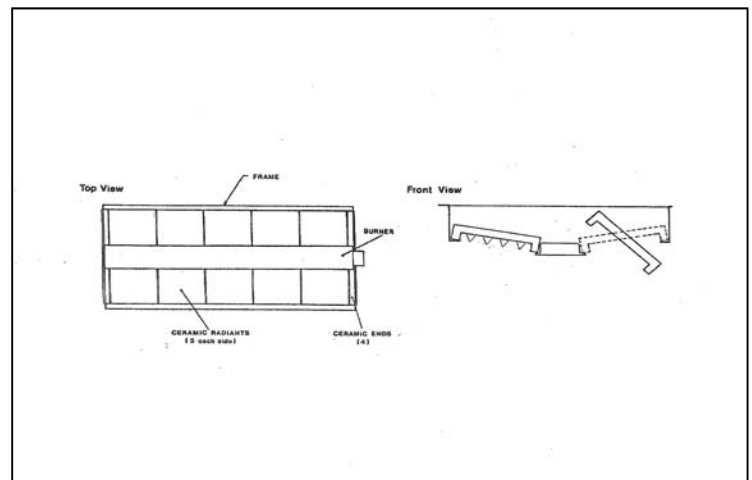

Visually inspect ceramic targets for damage ( cracks or broken radiant points) and replace as needed.

# SERVICE & ADJUSTMENT PROCEDURES

## Black Ball Knob

1. Remove the knob by unscrewing it (counterclockwise) from the Threaded Stud.
2. Replace the knob by screwing it (clockwise) onto the Threaded Stud.

## Chrome Sleeve

1. Turn off the Main Burner.
2. Allow the Salamander unit to cool to room temperature.
3. Remove the Black Ball Knob by unscrewing it (counterclockwise) from the Threaded Stud.
4. Remove the sleeve from the Tube/Threaded Stud assembly.
5. Replace the Chrome Sleeve by placing the sleeve onto the Threaded Stud.

## Threaded Stud

1. Turn off the Main Burner.
2. Allow the Salamander unit to cool to room temperature.
3. Remove the Black Ball Knob by unscrewing it (counterclockwise) from the Threaded Stud.
4. Remove the Chrome Sleeve from the Tube/Threaded Stud assembly.
5. Unscrew the Threaded Stud from the Tube.
6. Replace the Threaded Stud by performing the above steps in reverse order. Screw the Threaded Stud about 1" into the threaded end of the Tube.

## Gear and Tube Assembly Removal and Replacement Procedure

1. Turn off the Main Burner.
2. Allow the Salamander unit to cool to room temperature.
3. Remove the Front Control Panel according to the *Front Control Panel Removal and Replacement Procedure*.
4. Remove the Chrome Sleeve.
5. Remove the Gear with Bracket from the cabinet frame.

6. Slide the Gear and Tube Assembly off of the Carriage Position Handle Arm.
7. Replace the Gear and Tube Assembly by performing the above steps in reverse order.

## Compression Spring

1. Turn off the Main Burner.
2. Allow the Salamander unit to cool to room temperature.
3. Remove the Front Control Panel according to the *Front Control Panel Removal and Replacement Procedure*.
4. Remove the Gear with Bracket from the cabinet frame vertical member.
5. Remove the Tube and Gear Assembly.
6. Slide the Compression Spring off the Carriage Position Handle Arm.
7. Replace the Compression Spring by performing the above steps in reverse order.

## Gear with Bracket

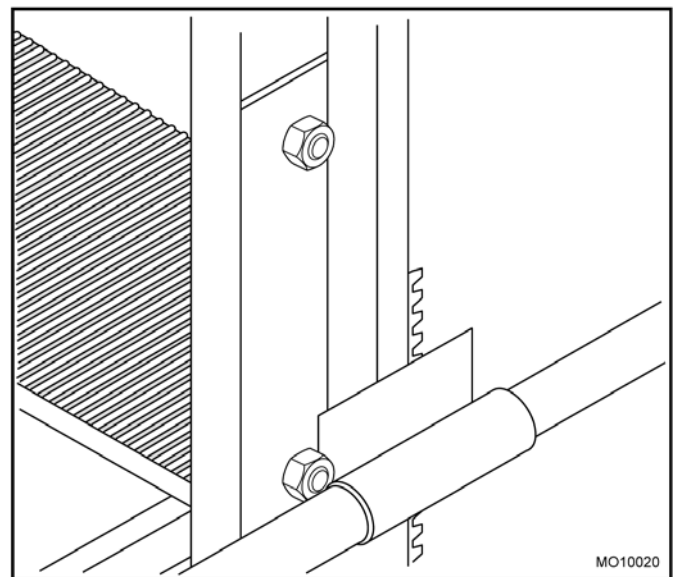

1. Turn off the Main Burner.
2. Allow the Salamander unit to cool to room temperature.
3. Remove the Front Control Panel as outlined under **COVERS AND PANELS**.
4. Remove the Black Ball Knob, Threaded Stud, Gear and Tube Assembly, and Compression Spring from the Carriage Position Handle.

# SERVICE & ADJUSTMENT PROCEDURES

5. Remove the two nuts that hold the Gear with Bracket to the vertical Frame Rail.
6. Replace the Gear with Bracket by performing the above steps in reverse order.

## CARRIAGE FRAME HANDLE REMOVAL AND REPLACEMENT PROCEDURE

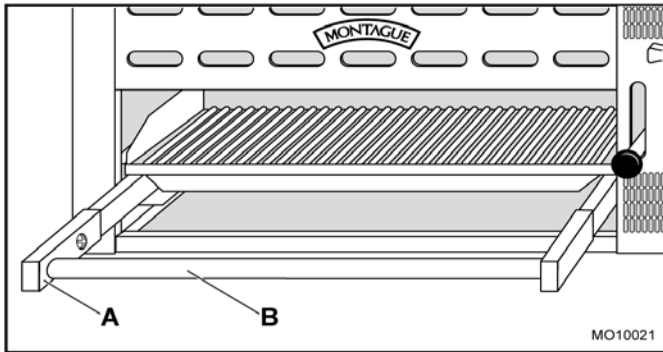

**Carriage Handle Assembly**

- A Handle support**
- B Handle**

1. Turn off the Main Burner.
2. Allow the Salamander unit to cool to room temperature.
3. Pull the Carriage Frame out until it stops.
4. Remove the Acorn Screw from one side of the handle.
5. Hold the handle while removing the handle support.
6. Slide the handle out of the still mounted handle support.
7. Replace the handle by performing the above steps in reverse order.

# SERVICE AND ADJUSTMENT PROCEDURES

**CAUTION:** Turn off the gas supply at the manual Shutoff Valve that is next to the Salamander unit before attempting to loosen any gas connections.

## GAS PRESSURE REGULATOR ADJUSTMENT PROCEDURE

**WARNING: DO NOT ALLOW UNTRAINED PERSONNEL TO MAINTAIN OR SERVICE THE GAS PRESSURE REGULATOR.**

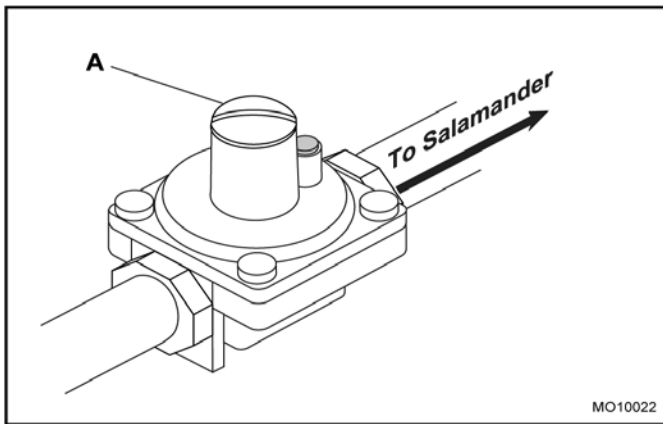

**Gas pressure regulator**

### A Seal cap

1. Before adjusting the Regulator, check the incoming gas line pressure. Incoming pressure must be 6.0" W.C. for Natural Gas, or 10" W.C. for Propane Gas.
2. If incoming pressure is not correct, have the gas source checked and adjusted as necessary.
3. Make sure that the Regulator is mounted in the horizontal position with the arrow pointing in the direction of the gas flow.
4. Connect a manometer to the pressure tap provided on the Salamander unit gas piping between the Regulator and the Salamander unit.
5. Check the manometer reading. The reading must be 6.0" W.C. for Natural Gas, or 10" W.C. for Propane Gas.
6. If incoming line pressure is not correct, adjust the Regulator. Remove the Seal Cap on the top of the Regulator.

7. Insert a blade-type screwdriver into the top hole of the Regulator.
8. Turn the adjustment screw clockwise to increase the pressure, or counterclockwise to decrease the pressure.
9. While watching the manometer, turn the adjustment screw to set proper Regulator outlet pressure.

## PILOT BURNER ADJUSTMENT PROCEDURE

1. Light the Pilot Burner as described in the *Installation and Operation Manual*.

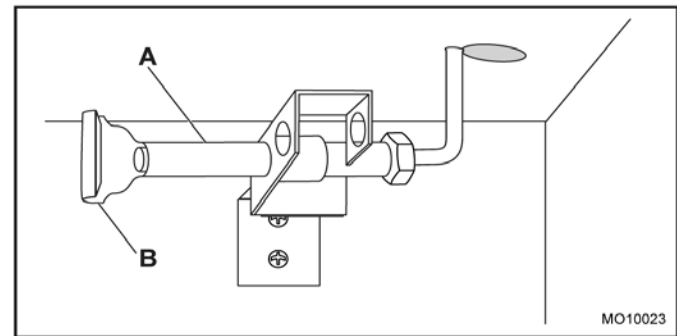

**Pilot burner**

### A Pilot burner

### B Flame shield

2. If the Pilot Burner flame burns yellow, clean the Pilot Burner Orifice and the Pilot Burner in order to ensure a steady blue flame. The Orifice can be cleaned by washing in a solvent such as trichloroethylene and/or blowing out with air.
3. If the Pilot Burner flame still burns yellow, replace the Pilot Burner Orifice.
4. If the Pilot Flame does not extend 1/2" beyond the outer edges of the Pilot Shield, or if it extends more than 1/2" beyond the outer edges of the Pilot Shield, an adjustment is necessary.

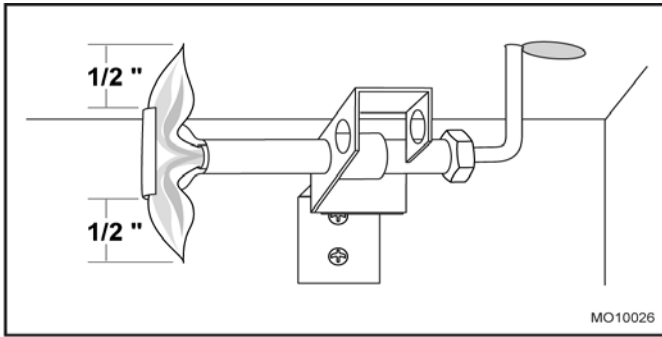

5. Remove the Front Control Panel according to the *Front Control Panel Removal and Replacement Procedure*.
6. Turn the Pilot Adjustment Valve Knob until 1/2" flames are observed.

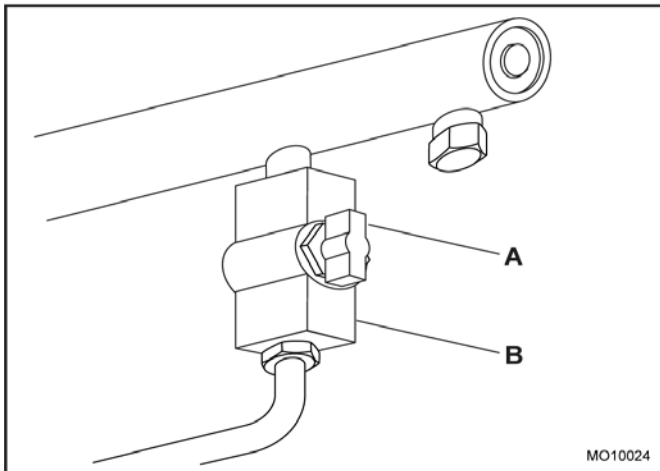

**Pilot adjustment valve**

- A Pilot adjustment valve knob
- B Pilot adjustment valve

### CARRIAGE POSITION HANDLE ADJUSTMENT PROCEDURE

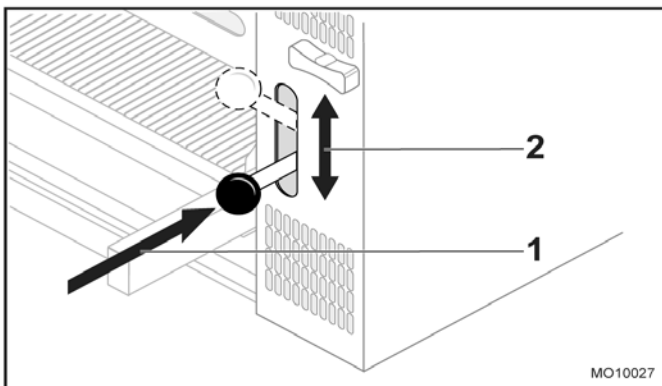

The Carriage Position Handle can be placed in a number of vertical positions.

1. Grasp the Black Ball Knob and press it in toward the Front Control Panel.
2. Raise or lower the Carriage Assembly to the desired height.
3. Release pressure on the Black Ball Knob to lock the Carriage Assembly at the desired height.

### Handle Tension Adjustment

If carriage is difficult to move or will not stay in place, the tension requires adjusting.

1. Remove black ball handle and chrome sleeve.
2. Turn threaded rod to the left to reduce tension; turn to the right to increase tension.
3. Replace chrome sleeve and black ball handle.

### CARRIAGE TENSION SPRING ADJUSTMENT PROCEDURE

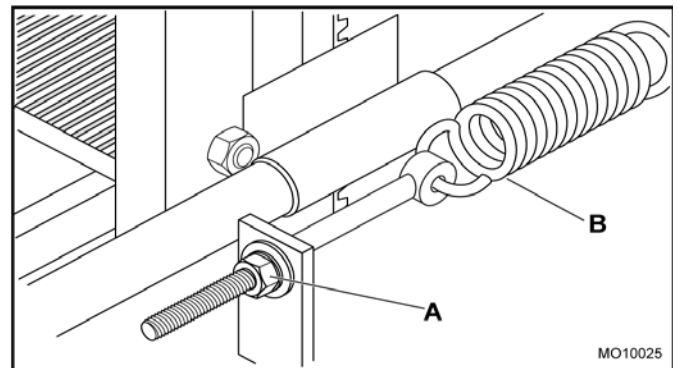

**Carriage tension spring**

- A Carriage tension spring adjustment nut
- B Carriage tension spring

1. Remove the Front Control Panel according to the *Front Control Panel Removal and Replacement Procedure*.
2. Locate the Carriage Tension Spring Adjustment Nut at the bottom of the cabinet.
3. Turn the nut clockwise to increase tension or counterclockwise to reduce tension.
4. Move the Carriage Position Handle up and down to check for proper tension.
5. Replace the Front Control Panel according to the *Front Control Panel Removal and Replacement Procedure*.

# TROUBLESHOOTING CHART

SYMPTOM	CAUSE	REMEDY
Pilot Burner flames are burning yellow.	Gas too rich	Perform the <i>Pilot Burner Adjustment Procedure</i> .
	Clogged pilot air passages	Perform the <i>Pilot Burner Orifice Removal and Replacement Procedure</i> .
	Pilot not properly adjusted	Perform the <i>Pilot Adjustment Valve Adjustment Procedure</i> .
Pilot Burner flames are less than or more than 1/2".	Pilot not properly adjusted	Perform the <i>Pilot Burner Adjustment Procedure</i> .
Pilot Burner flames cannot be adjusted.	Faulty Pilot Burner	Perform the <i>Pilot Burner Removal and Replacement Procedure</i> .
	Faulty Pilot Adjustment Valve	
Main Burner flame cannot be adjusted.	Faulty or dirty Orifice	Check and clean as necessary.
	Dirty Venturi passage	Perform the <i>Main Burner Orifice Removal and Replacement Procedure</i> .
	Faulty Main Burner valve	Perform the <i>Main Burner Removal and Replacement Procedure</i> .
Main Burner heat is not uniform over the surface of the ceramic tiles.	Faulty Main Burner	Perform the <i>Main Burner Removal and Replacement Procedure</i> .
	Wrong gas pressure	Check and adjust gas pressure.
Carriage Assembly will not stay at a set height position.	Improper Handle spring tension adjustment	Perform the <i>Handle Tension Adjustment Procedure</i> .
	Worn or broken Gear with Flange	Perform the <i>Gear with Flange Removal and Replacement Procedure</i> .
Carriage Assembly moves up and down too easily or too hard.	Improper Carriage spring tension adjustment	Perform the <i>Carriage Tension Spring Adjustment Procedure</i> .

# EXPLODED VIEW

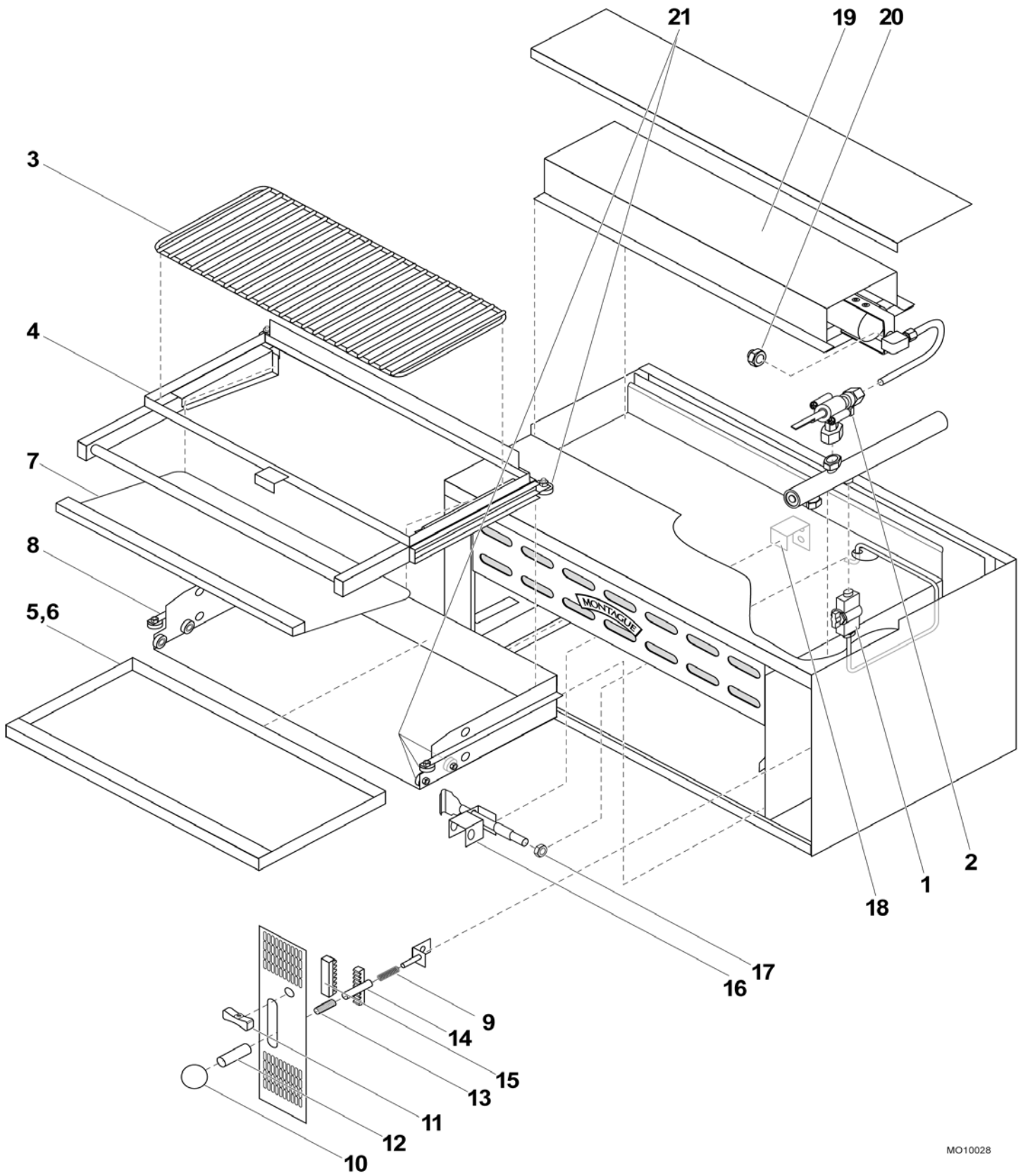

MO10028

# PARTS LIST

## PARTS FOR ALL MODELS

Item	Part No.	Description	Quantity
1	22818-4	Valve, Pilot Adjustment	1
2	01068-5	Valve, Main Burner	1
3	09006-9	Grid, Wire (13-1/8" x 26-3/4")	1
4	17660-5	Grid Frame	1
5	09198-7	Drip Pan, Standard (fits below Grid)	1
6	25900-4	Drip Pan, Stainless Steel (fits below Grid)	1
7	09196-0	Shield, Grease Deflector	1
8	17655-9	Carriage Assembly w/Bearings	1
9	32756-5	Spring, Carriage Position Handle (7/16" D x 2-1/16" L)	1
10	02033-8	Knob, Black Ball, Carriage Position Handle	1
11	<a href="#">38485-2</a>	Valve Handle w/ Set Screw - ( For Technostar p/n 50689-3) (For Units prior to 02/09 p/n 2002-8)	1
12	03504-1	Sleeve, Carriage Position Handle	1
13	03506-8	Stud, Threaded, Carriage Position Handle	1
14	03502-5	Gear and Tube Assembly, Carriage Position Handle	1
15	09208-8	Gear with Bracket (mates with 03502-5)	1
18	9182-0	Pilot Mounting Bracket	1
21	2013-3	Bearings	6

## PARTS FOR NATURAL GAS MODELS ONLY

Item	Part No.	Description	Quantity
16	01019-7	Pilot Burner Assembly, Natural Gas	1
17	02193-8	Pilot Burner Orifice, Natural Gas	1
19	09308-4	Main Burner Assembly w/Natural Gas Orifice (28-1/4" L), includes Elbow w/Nut and Sleeve	1
20	09311-4	Orifice, Main Burner, Natural Gas (for 09308-4)	1

## PARTS FOR PROPANE GAS MODELS ONLY

Item	Part No.	Description	Quantity
16	01020-0	Pilot Burner Assembly, Propane Gas	1
17	09313-0	Pilot Burner Orifice, Propane Gas	1
19	09314-9	Main Burner Assembly w/Propane Gas Orifice (28-1/4" L), includes Elbow w/Nut and Sleeve	1
20	09313-0	Orifice, Main Burner, Propane Gas (for 09314-9)	1

# CARRIAGE STABILIZER COMPONENTS

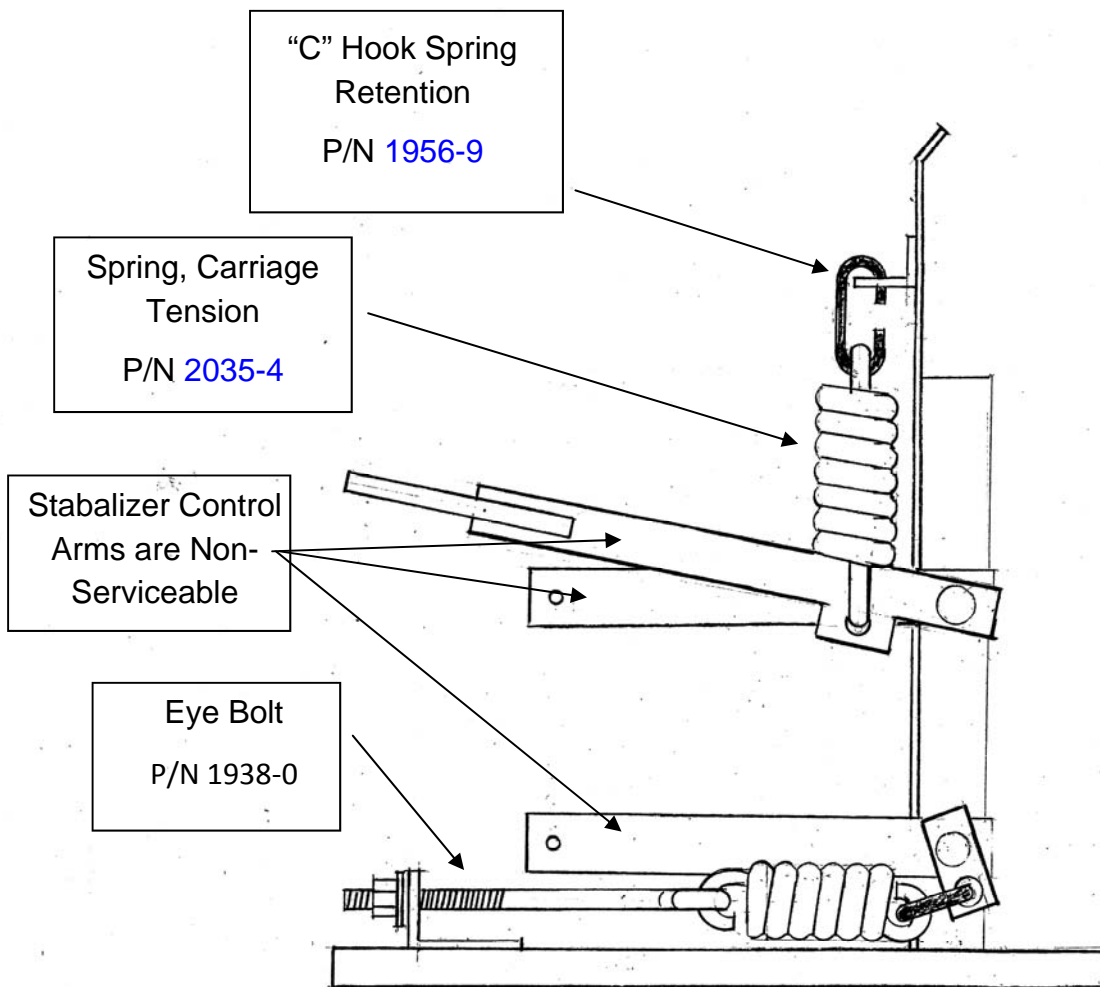

# SALAMANDER BROILER 3618

## BURNER ASSEMBLY

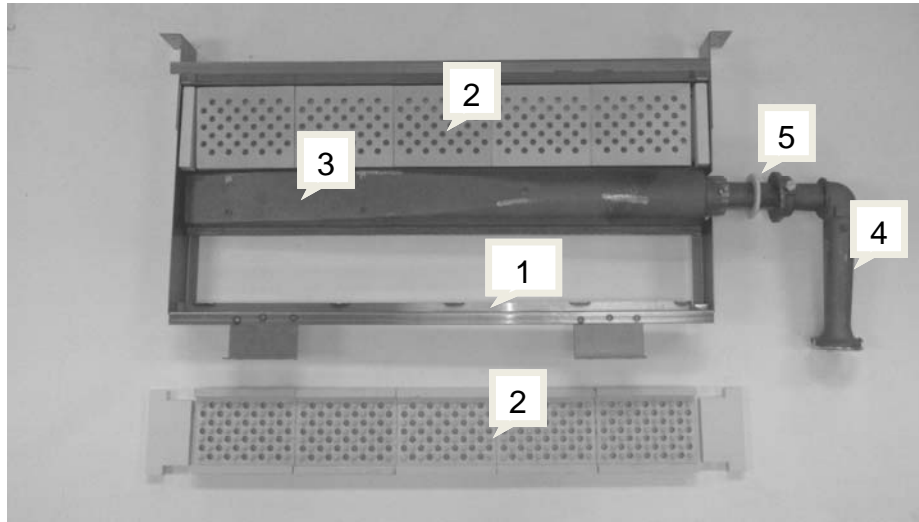

ITEM #	DESCRIPTION	PART NUMBER
#1	BURNER FRAME	4382-6
#2	CERAMIC KIT	28387-8
#3	BURNER ASSEMBLY	4276-5
#4	VENTURI W AIR MIXER	26940-9
#5	BURNER GASKET	20923-6

**\*NOTE\*** Burner Gasket (item #5) should always be replaced when servicing burner.

## SB36 BURNER ASSEMBLY

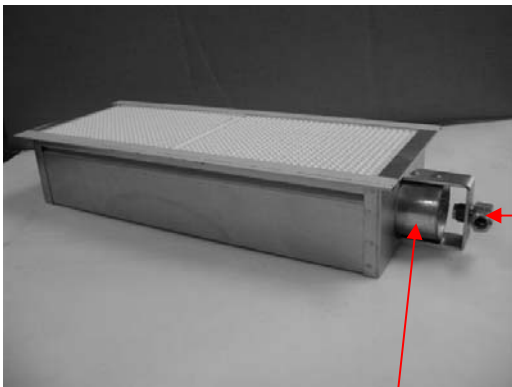

KEEP VENTURI CLEAR OF GREASE & LINT  
TO INSURE PROPER BURNER  
PERFORMANCE

ORIFICE ELBOW ASSEMBLY  
NAT - 17238-3 LP - 9312-2

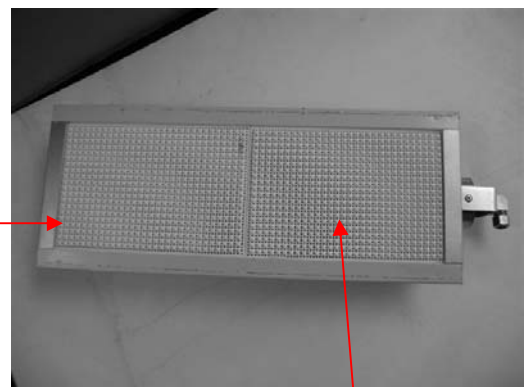

CERAMICS ARE NOT SERVICEABLE. IF  
CERAMICS ARE CRACKED OR DAMAGED,  
BURNER WILL NEED TO BE REPLACED.

BURNER HAS SEAL AROUND PERIMETER OF  
CERAMICS. IF SEALS ARE DAMAGED BURNER  
WILL NEED TO BE REPLACED.

# SALAMANDER BROILER 3618

## MANIFOLD ASSEMBLY

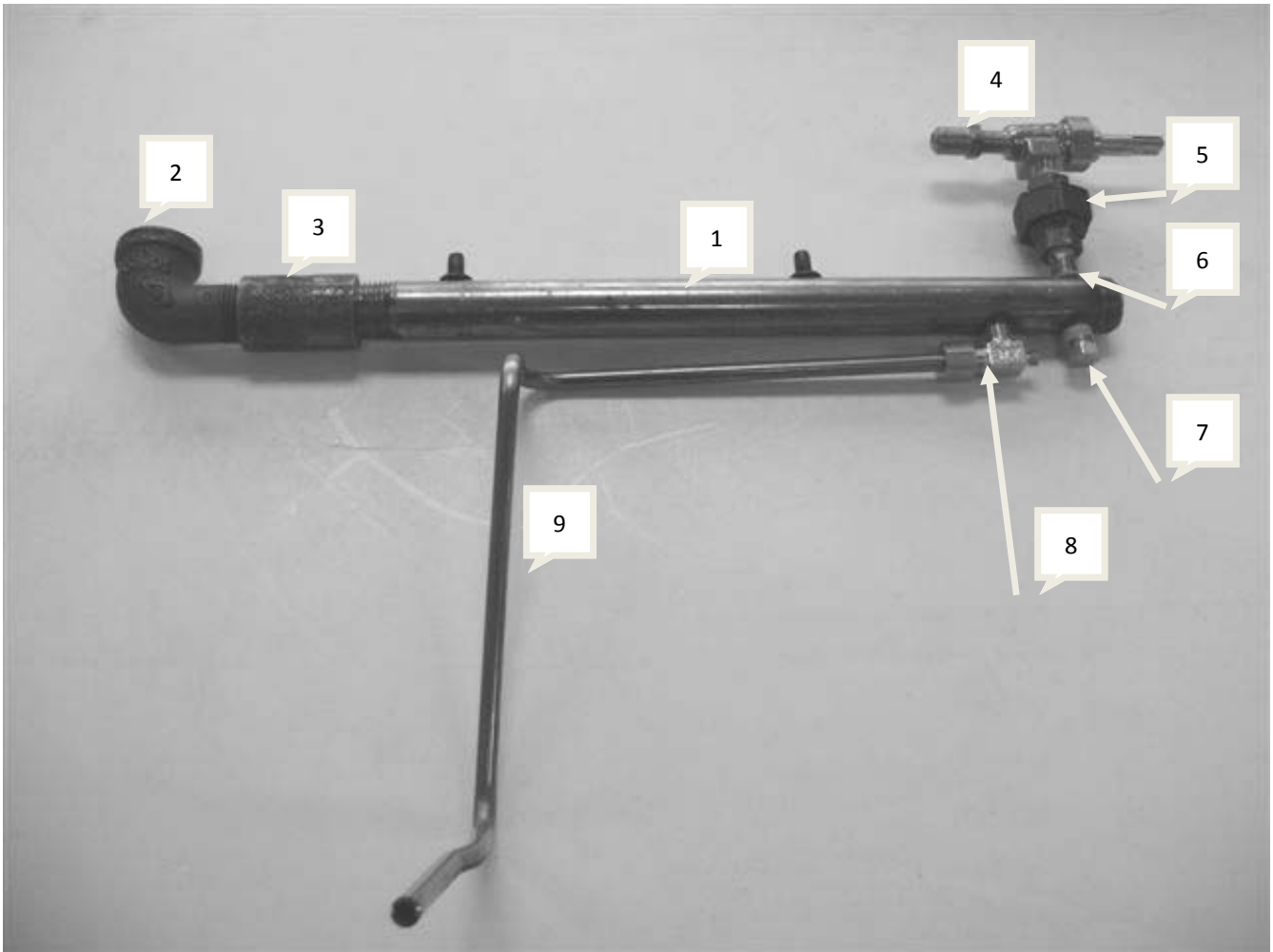

ITEM #	DESCRIPTION	PART NUMBER
#1	MANIFOLD	7341-5
#2	ELBOW - STREET, PIPE	14666-8
#3	PIPE COUPLING	2651-4
#4	VALVE / LESS HOOD	<a href="#">2569-0</a>
#5	PIPE UNION	<a href="#">1187-8</a>
#6	PIPE NIPPLE	<a href="#">1146-0</a>
#7	HEX PIPE PLUG	<a href="#">1279-3</a>
#8	PILOT VALVE	<a href="#">1000-6</a>
#9	PILOT TUBING	<a href="#">26920-4</a>

# NOTES

---

## **WARNING**

**If not installed, operated and maintained in accordance with the manufacturer's instructions, this product could expose you to substances in fuel or in fuel combustion which can cause death or serious illness and which are known to the State of California to cause cancer, birth defects or other reproductive harm.**

The State of California enacted the California Safe Drinking Water and Toxic Enforcement Act of 1986, (Prop. 65), which "prohibits any person in the course of doing business from knowingly and intentionally exposing any individual to a chemical known to the State of California to cause cancer or reproductive toxicity without first giving clear and reasonable warning to such individuals." The Governor's Scientific Advisory Panel added carbon monoxide to the list of hazardous chemicals known to cause reproductive harm.

In order to establish full compliance with Proposition 65, we attached a yellow warning label to each gas fired unit manufactured by the Montague Company.

Carbon monoxide would not be present in concentrations that would pose a "significant risk" to the consumer when the equipment is installed, operated and maintained as follows:

1. Installed in accordance with all local codes, or in the absence of local codes, with the current National Fuel Gas Code 2223.1.
2. Installed under a properly designed and operating exhaust hood.
3. Connected to the type of gas for which the unit is equipped.
4. Proper appliance pressure regulator installed on the gas supply line and adjusted for the manifold pressure marked on the rating plate.
5. Adequate air supply to the unit.
6. The equipment is operated in the manner intended using the proper utensil for that type of appliance.
7. Keep the equipment clean and have it checked periodically.
8. Burner air adjustments, mechanical maintenance and repairs should be performed by qualified service personnel.

If the equipment is not installed, operated and maintained in accordance with the above, concentrations of carbon monoxide in excess of the established limits could be present in the kitchen environment.

***ALL PERSONNEL IN THE WORKPLACE WHO MAY BE SUBJECT TO ANY EXPOSURE OF CARBON MONOXIDE MUST BE WARNED OF SUCH POSSIBLE EXPOSURE. THIS WARNING SHOULD BE CONVEYED IN A MANNER SO THAT IT IS CLEARLY UNDERSTOOD BY THE EMPLOYEE, AND THE EMPLOYEE SHOULD BE ASKED IF IN FACT HE OR SHE UNDERSTANDS THE CORRECT METHOD OF OPERATION OF THE EQUIPMENT AND THAT A RISK OF EXPOSURE EXISTS IF THE EQUIPMENT IS OPERATED IMPROPERLY.***



**SAVE THESE INSTRUCTIONS  
FOR FUTURE USE.**

---

**The MONTAGUE Company**

1830 Stearman Ave. • P.O. Box 4954 • Hayward, CA 94540-4954

Tel: 510/785-8822 • Fax: 510/786-9931

1-888-875-2722

[WWW.MONTAGUECOMPANY.COM](http://WWW.MONTAGUECOMPANY.COM)