

# INSTRUCTION MANUAL

**MONTAGUE LEGEND**

**Heavy Duty Underfired**

**Gas Broilers**

## **RADIANT MODELS:**

**Range Match: UF (24R, 30R, 36R, 48R, 60R, 72R)**

**Freestanding: UFS (24R, 30R, 36R, 48R, 60R, 72R)**

**Low-Profile Counter: UFLC (18R, 24R, 30R, 36R, 48R, 60R, 72R)**

**Modular: UFSM (24R, 30R, 36R, 48R, 60R, 72R)**

**Counter: UFSC (24R, 30R, 36R, 48R, 60R, 72R)**

**Shallow Counter: UFLCS (18R, 24R, 30R, 36R, 48R, 60R, 72R)**

**These instructions should be read thoroughly before attempting installation.  
Set up and installation should be performed by qualified installation personnel.**

**Keep area around appliances free and clear from combustibles.**

**PLEASE RETAIN THIS MANUAL  
FOR FUTURE REFERENCE.**



**THE MONTAGUE COMPANY**

1830 Stearman Avenue

P.O. BOX 4954

Hayward, CA 94540-4954

TEL: (510) 785-8822 FAX: (510) 785-3342

# TABLE OF CONTENTS

<b>Important (Cautions and Warnings)</b> .....	<b>Page 1</b>
<b>Installation</b> .....	<b>Page 2 - 5</b>
<b>Operation</b> .....	<b>Page 6</b>
<b>Maintenance</b> .....	<b>Page 7 - 9</b>
<b>Maintenance Schedule</b> .....	<b>Page 10</b>
<b>Service</b> .....	<b>Page 11</b>
<b>Orifice Size Chart - Drill Size</b> .....	<b>Page 12</b>
<b>UF Exploded View</b> .....	<b>Page 13</b>
<b>Exploded View Parts List</b> .....	<b>Page 14 - 15</b>
<b>UFLC Exploded View</b> .....	<b>Page 16</b>
<b>UFLC Exploded View Parts List</b> .....	<b>Page 17-18</b>

## SHIPPING DAMAGE CLAIM PROCEDURE

For your protection, please note that equipment in this shipment was carefully inspected and packed by skilled personnel before leaving the factory. The transportation company assumed full responsibility for safe delivery upon acceptance of this shipment.

### **If shipment arrives damaged:**

1. **VISIBLE LOSS OR DAMAGE** - Be certain this is noted on freight bill or express receipt, and signed by person making delivery.
2. **FILE CLAIM FOR DAMAGES IMMEDIATELY** - Regardless of the extent of damage.
3. **CONCEALED LOSS OR DAMAGE** - If damage is unnoticed until merchandise is unpacked, notify transportation company or carrier immediately, and file "concealed damage" claim with them. This should be done within fifteen (15) days of date that delivery was made to you. Be sure to retain container for inspection.

*We cannot assume responsibility for damage incurred in transit. We will, however, be glad to furnish you with the necessary documents to support your claim.*

# IMPORTANT

FOR YOUR SAFETY



## **WARNING**

***IMPROPER INSTALLATION, ADJUSTMENT, ALTERATION, SERVICE OR MAINTENANCE CAN CAUSE PROPERTY DAMAGE, INJURY OR DEATH. READ THE OPERATING AND MAINTENANCE INSTRUCTIONS THOROUGHLY BEFORE INSTALLING OR SERVICING THIS EQUIPMENT.***



## **WARNING**

***DO NOT STORE OR USE GASOLINE OR OTHER FLAMMABLE VAPORS AND LIQUIDS IN THE VICINITY OF THIS OR ANY OTHER APPLIANCE.***

**NOTE:** This manual has been prepared for personnel qualified to install commercial equipment who should perform the initial field start-up and the adjustments of the equipment covered by this manual.

**NOTE:** Instructions to be followed in the event the user smells gas must be posted in a prominent location. This information may be obtained by consulting the local gas supplier.

# INSTALLATION

The Montague gas broilers are produced with the best possible materials and workmanship.

**Proper installation is essential for safe and efficient trouble-free operation.**

**NOTE:** The installation instructions contained herein are for the use of qualified installation and service personnel only. Installation or service by other than qualified personnel may result in damage to the oven/injury to the operator.

Qualified installation personnel are individuals, a firm, corporation, or company which either in person or through a representative are engaged in, and are responsible for:

The installation or replacement of gas piping or the connection, installation, repair or servicing of equipment, who is experienced in such work, familiar with all precautions required, and has complied with all requirements of state or local authorities having jurisdiction. Reference: National Fuel Gas Code Z223.1-NFPA54 - latest addenda, Section 3.3.175.

**Read carefully and follow these instructions.**

The oven must be installed in accordance with the local codes, or in the absence of local codes, with the national fuel gas code, ANSI Z223.1-NFPA54-latest addenda or the natural gas and propane installation code CSA b149.1 as applicable, including:

1. The appliance and its individual shutoff valve must be disconnected from the gas supply piping system during any pressure testing of that system at test pressures in excess of 1/2 psig. (3.45 kPa).
2. The appliance must be isolated from the gas supply piping system by closing its individual manual shutoff valve during any pressure testing of the gas supply piping system at test pressure equal to or less than 1/2 psig. (3.45 kPa).

**Provisions must be made for adequate air supply to the unit.**

## VENTILATING HOOD

The broiler must be installed under a properly designed ventilating hood. The hood should extend at least 6" beyond all sides of the unit. The hood should be connected to an adequate mechanical exhaust system.

Information on the construction and installation of ventilation hoods may be obtained from the "Standard for the Installation of Equipment for the Removal of Smoke and Grease Laden Vapors from Commercial Cooking Equipment," NFPA No. 96-latest addenda, available from the National Fire Protection Association, Batterymarch Park, Quincy, MA 02269.

It is also necessary that the sufficient room air ingress be allowed to compensate for the amount of air removed by the ventilation system. Otherwise, a subnormal atmospheric pressure will occur which may interfere with burner performance or may extinguish the pilot flame. In case of unsatisfactory oven performance, re-check performance with the exhaust fan turned "OFF."

# INSTALLATION

CLEARANCES	
Models	Noncombustible Construction
<b>UF, UFS, UFSC &amp; UFSM</b>	
Back	0"
Left & Right Side	0"
<b>UFLC</b>	
Back	0"
Left & Right Side	0"
 <b>WARNING: FOR USE IN NON-COMBUSTIBLE LOCATIONS ONLY.</b>	



## CAUTION

**DO NOT OBSTRUCT THE FLOW OF COMBUSTION AND VENTILATION AIR TO THE BROILER(S). KEEP THE APPLIANCE AREA FREE AND CLEAR FROM COMBUSTIBLES.**

## SETTING IN PLACE

1. Uncrate unit and put into place. For easier and lighter handling of the broiler, remove cast iron top grids, grid frame, drip tray, grease container, and debris screen.
2. Wire ties securing burners are for shipping purposes only and must be removed when installing the appliance. This will permit the burners to be readily removed during future servicing. Remove all other packing material from burner box.
3. For floor models, a set of 6" legs is packed in the top section of the broiler (unless unit is specifically ordered without legs). A

threaded receptacle is located on each corner (and in the middle of units larger than 36") of the base of the unit. Each leg has a similar mating thread. Raise unit sufficiently to allow legs to be screwed into the threaded receptacles. Level unit by adjusting legs. **An unlevelled unit will adversely affect performance.**

4. Counter units must be installed on a level table or stand, and modular units must be leveled by adjusting the legs.

## BATTERY ARRANGEMENTS

1. Place the first unit in the exact position it will occupy in the battery.
2. Using a carpenter's level, level the unit from front to rear and side to side. Adjust as follows:

## FLOOR INSTALLATION ON LEGS

Adjust by turning foot on adjustable legs.

# INSTALLATION

## CURB INSTALLATION

Place shim under the low side. This operation is important since variations in floors and curbs are common. Unless units are level, difficulty will be encountered in aligning the gas supply manifold and the units will not unitize correctly.

3. Remove valve panel.
4. Move the next unit into position.
5. Engage union nut on manifold with make fitting on next unit and draw up union nut hand tight. Be sure appliances butt together both front and rear. If manifolds do not align, then ranges are not level. In extreme cases, it may be necessary to loosen manifold bolts and adjust.
6. Continue leveling and connecting gas supply manifolds together until all appliances in the battery are connected.
7. Tighten manifold union gas tight. Use back up wrench to prevent manifold from rotating. **Failure to do this may result in damage to pilots and gas valves. Check entire system for gas leaks.**

## GAS HOOK UP

An adequate gas supply is imperative. Undersized or low pressure lines will restrict the flow of gas required for satisfactory performance. A steady supply pressure between 7" and 8" WC for natural gas and 11" to 12" WC for propane gas is required. With all units operating simultaneously, the manifold pressure on all units should not show any appreciable drop. Fluctuation of more than 25% on natural gas and 10% on propane gas will create pilot problems and affect burner operating characteristics. Contact your gas company for correct supply line sizes.

The unit should be connected only to the type of gas for which it is equipped. Check type of

gas on rating plate.

1. 1-1/4" Front Manifold

The gas manifold of this appliance or of the battery which it is a part must be connected to a gas appliance pressure regulator adjusted for the manifold pressure marked on the rating plate.



### **IMPORTANT**

**THIS UNIT IS EQUIPPED WITH FIXED ORIFICES FOR THE TYPE OF GAS MARKED ON THE RATING PLATE. THE ORIFICES ARE SIZED FOR THE FOLLOWING GAS PRESSURE:**

**NATURAL: 6.0" WC**

**PROPANE GAS: 10.0" WC**

1" Rear Manifold (Standard)

3/4" Rear Manifold for Models UFLCS & UFS

The gas pressure regulator supplied with this unit must be used.

### **For Natural Gas**

The gas pressure regulator is factory adjusted for 6.0" WC manifold pressure. The maximum inlet pressure to the regulator should not exceed manufacture's rating of 1/2 psi or damage to the regulator may occur.

### **For Propane Gas**

The gas pressure regulator is factory adjusted for 10.0" WC manifold pressure. The maximum inlet pressure to the regulator should not exceed manufacturers rating of psi or damage to the regulator may occur.

2. Use a pipe joint compound which is suitable for use with Propane gas on all threaded connections.
3. Manifold pressure must be maintained at

# INSTALLATION

the pressure marked on the rating plate — 6.0" WC for natural and 10.0" WC for propane gas.

4. Turn off all burner valves.
5. Turn on gas supply and check all unions for leaks. Use soapy water only for testing on all gases. **Never use an open flame to check gas leaks.**



## **IMPORTANT**

***IF PRESSURE TESTING PLEASE DO NOT EXCEED FACTORY SPECIFICATION OF 1/2 PSI OR DAMAGE TO REGULATOR MAY OCCUR.***



## **WARNING**

***UNITS OVERGASSED MAY CAUSE PREMATURE FAILURE OF COMPONENTS, SUCH AS, BURNER VALVES, BURNERS, RADIANT REFLECTOR, RADIANTS, BURNER BOX, AND DEBRIS SCREEN.***

## **FINAL ASSEMBLY**

Reinstall the grid frame and top grids and check for proper operation of the grid adjustment lever. Check to be certain that all tie wires have been removed from the burners and that the reflectors and radiants are properly positioned between their alignment notches. Replace the drip tray grease container, debris screen, and heat shields.

## **GAS SETTINGS**

### **Pilot Lighting Instructions**

1. Remove debris screen and light each pilot with extended lighter from underneath. Replace screen.
2. Set pilot valve with screwdriver to provide 1/2" flame by turning counterclockwise.
3. Turn desired burner valve on.

4. To shutdown, turn pilot valve clockwise until tight.
5. Do not attempt to relight for 5 minutes after shutdown.

The burner flame should be 1-1/2" to 2" high on natural gas and approximately 3/4" to 1" on propane gas. Turn the gas valve on and off several times and observe the flames on the burners. If they are yellow and soft, open the air shutter slightly or until yellow disappears. If flames seem to blow or lift from burner ports, close the air shutter until this does not occur. Secure air shutter after burner has been adjusted.

# OPERATION

## HEATING

Be sure all standing pilots are lit. Turn on the number of burners desired, to the full “ON” position. After 20 minutes, the flame can be turned back if less heat is desired. At broiling temperature, the radiants will reach a dull, red color with brighter areas at the edges. They generate the radiant heat necessary for fast broiling.

## ADJUSTMENT OF TOP COOKING GRID UF, UFS, UFSC & UFSM Models

To provide the operator with greater control over the cooking operation, a grid adjustment lever is located on the right side of the broiler cabinet. The rear of the grid can easily be adjusted during broiling into three position: 1) Horizontal—for heating with pots or pans, or broiling round products (such as sausages) that could roll off. 2) Moderately Tilted—recommended for most broiling to maintain adequate drain-off of fat drippings and 3) Steeply Angled—to achieve maximum drain-off of fat drippings from high-fat products, or to reduce flare-ups during peak broiling periods. Some drippings will obviously fall onto the hot radiants and create the smoke and charcoal broiled flavor exclusive to char-broiling.

## UFLC Models

With the top grids removed, the grid frame can be positioned by locating the rear support rod on the grid frame. With the rod extended and locked into the rear supports, the grids will drain off fat drippings produced during broiling. By retracting the rod, the grid frame will lay flat for heating pots or broiling round products. **Never try to position the grid frame while the broiler is operating or still hot!**

## COOKING

The Montague Heavy Duty Underfired Gas Broilers were designed and built to outperform and outlast any other broilers available. They

exhibit characteristics that chefs require to achieve high production broiling perfection.

## High Heat Capacity

The burners have been sized to maintain the 550°F—650°F broiling temperature better during peak loads. All products mark quickly and cook predictably.

## Even Grid Temperatures

Temperatures throughout the greater middle and rear portions of the grid remain consistent. Slightly cooler sections exist at the front and outer edges of the grid to accommodate products that need to cook more slowly.

## Ultra-Flow Top Grids

Wide spacing of ribs combined with generous openings for deeper penetrating radiant heat waves results in the ideal broiling atmosphere. Meats sear efficiently with more of the flavor and juices locked inside.

## Optimum Fat Drain-Off

Large continuous troughs on the top side of the broiling grids drain excess fat quickly. Adjustable grid angle allows for added control of flare-ups.

## CONVENIENT LOWER WARMING RACK, (UF, UFS, UFSC & UFSM Models):

Expand the flexibility of your broiling operation with a lower rack option. It can be used as a holding area for cooked products or warming shelf for plates and platters.

## WARNING

**LINING UNITS WITH FOIL MAY CAUSE PREMATURE COMPONENT FAILURE NOT COVERED UNDER WARRANTY.**

# MAINTENANCE

## GENERAL CLEANING

The complete broiler should be given a periodic cleaning. Lint and grease suspended in the air tend to collect in air passages.

### Exterior

#### PAINTED SURFACE

Allow equipment to cool before cleaning exterior surfaces. Painted surfaces should be cleaned using a mild soap and warm water solution on a sponge or soft cloth.

Powder coated, copper, and other such painted or plated finishes are not covered under warranty. These finishes are subject to wear and may begin to discolor and/or chip within a short period of time. Caution should be taken when cleaning. Using a mild soap and water solution will help to maintain the look and finish.

#### STAINLESS STEEL SURFACES

Stainless steel is an alloy of iron which contains chromium. In the process of manufacturing stainless steel, chromium in the alloy is used to form the hard oxide coating on the surface. If this is taken off through corrosion or wear, it will rust like regular steel.

To remove dirt, grease or product residue from stainless steel, use water and a mild detergent if needed, applied with a sponge or lint-free cloth. Dry thoroughly with a lint-free cloth.

To remove grease and food splatter, or condensed vapors that have baked on the equipment, you can use a (non-abrasive) commercial cream cleanser or baking soda and water, applied with a damp lint-free cloth or sponge. Rub cleanser as gently as possible (with grain) in the direction of the polished lines. **Do not rub in a circular motion**, it will damage the finish. Rinse surface after cleaning with a damp lint-free cloth and clean

water. Dry thoroughly with a clean lint-free cloth. Drying thoroughly will prevent water spots which are harmful to the finish.



### CAUTION

**NEVER USE ABRASIVES, POWDERS, HARSH LIQUIDS, CAUSTICS, OR DYES AS THEY MAY LEAVE A FILM OR RESIDUE THAT WILL CLOG THE PORES OF THE SPECIAL COATING.**

#### Precautions

- Strong bleaches tend to corrode many materials and should not come in contact with stainless steel sinks or utensils longer than 30 minutes. When these chemicals are used, the stainless should be rinsed thoroughly.
- Tincture of iodine or iron should not remain in contact with stainless surfaces. These solutions which cause stainless to discolor, should be rinsed off immediately after contact.

Some foods, such as mustard, mayonnaise, lemon juice, vinegar, salt or dressings containing these, will attack and corrode stainless. You should never store them in stainless containers.

- Ordinary steel wool pads should be not used to clean stainless; particles may lodge in the surface and rust. Allowing the steel wool pad to rest on a stainless surface may cause a rusty appearance. For difficult cleaning jobs such as removing burned-on foods, nylon "sponges" or pads are recommended. When cleaning a highly polished, mirror finish, a nylon pad should be used to avoid scratching the finish.
- Gritty, hard abrasives will mar a stainless finish and are not recommended.

# MAINTENANCE

- Sharp knives or choppers usually have hard carbon steel edges and will leave their mark on stainless surfaces.

With only a little care, your stainless steel equipment and utensils will remain clean and bright for years to come. Stainless is hard, rust-resisting metal that adds beauty and luster to countless household products.

## Helpful Hints

- To remove streaks, rub stainless steel surface with olive oil.
- To clean and polish, simply moisten a lint-free cloth with undiluted white or cider vinegar and wipe clean. Vinegar can also be used to remove heat stains.
- Oil from fingerprints can etch or tarnish stainless steel, especially mirror-polished finishes. Wherever stainless steel is visible, use a glass cleaner to remove fingerprints at the end of the day, before the finish is permanently damaged.

## Top Grids

### DAILY

Clean both sides regularly with a wire brush. Special attention should be given to the grease troughs on either side of the grid ribs, since this is where the rendered fat from the broiling operation runs off. If accumulation of carbon develops there, the fats will build up and drop from the points of carbon instead of running all the way down to the end of the grid into the grease trough.

### WEEKLY

The grids should be removed at least once a week and be scrubbed thoroughly. If done regularly, minimal effort is needed. If neglected, more drastic measures must be used.

## Radiants

Stainless steel radiants require only occasional cleaning since most food particles don't stick to their surface. They should be inspected weekly, and if cleaning is required, hot soapy water is best. Cast iron radiants are also self cleaning. If occasional cleaning is required, a wire brush and soapy water is usually adequate. Dry thoroughly before returning to the broiler.

## Burners

Under normal use, burners should not require cleaning, but periodic inspection for heat deterioration is recommended.

## Grease Containers

Each unit contains at least one small grease container to catch grease, (in the far left hand corner of the broiler), and at least one large tray to catch drippings from the broiler. The large tray should be removed every couple of days and washed thoroughly. The small grease container should be removed daily to empty accumulated grease and avoid overflow. This should be done while warm so that the grease is in a liquid state. The shield over the grease can protect it from the intense infrared rays, avoiding a fire hazard. When these pans are out, it's a good idea to wipe out the interior of the unit with a warm soapy cloth to prevent grease and carbonization buildup. The heat shields in UFLC models should be removed and cleaned daily in warm, soapy water.

## Debris Screen

A removable debris screen is located above the drip tray to catch large particles that fall through the broiling grids. This should be removed and cleaned daily.

# MAINTENANCE

## Radiant Reflectors

The radiant reflectors located beneath the burners in UFLC models should be removed weekly and scrubbed to remove grease and debris. Dry thoroughly before reinstalling.



### **WARNING**

**COVERING THE GRATES AND BURNER BOX FOR “BURN OFF” CLEANING WILL CAUSE PREMATURE COMPONENT FAILURE THAT IS NOT COVERED UNDER THE WARRANTY.**

# MAINTENANCE SCHEDULE

<b>Product Maintenance Schedule</b>												
<b>Components</b>	<b>Jan</b>	<b>Feb</b>	<b>Mar</b>	<b>Apr</b>	<b>May</b>	<b>June</b>	<b>July</b>	<b>Aug</b>	<b>Sept</b>	<b>Oct</b>	<b>Nov</b>	<b>Dec</b>
Pilots	1,2			1,2			1,2			1,2		
Burner						1,2						1,2
Burner Valve	1,5			1,5			1,5			1,5		
Regulator						1,2						1,2
Top Grids*	2	2	2	2	2	2	2	2	2	2	2	2
Grid Frame	1			1			1			1		
Radiant Reflector						1,4						1,4
Radiant						1,4						1,4
Grease Container*	2	2	2	2	2	2	2	2	2	2	2	2
Debris Screen*	2	2	2	2	2	2	2	2	2	2	2	2

(1) Inspect      (2) Clean      (3) Adjust      (4) Replace (As Needed)      (5) Lubricate

NOTE: Lack of maintenance may result in pre-mature failure of components.

NOTE: Parts marked with \* should be cleaned daily.

NOTE: Maintenance schedule may vary due to the gas heating value per country.

# SERVICE

When service is needed, contact a local service company, dealer, or the factory to perform mechanical maintenance and repairs. These instructions are intended for use by competent service personnel.

## CAUTION

**TURN OFF GAS AT MANUAL SHUT OFF VALVE NEXT TO THE APPLIANCE BEFORE ATTEMPTING TO LOOSEN ANY GAS CONNECTIONS.**

## WARNING

**NO UNTRAINED PERSON SHOULD ATTEMPT TO MAINTAIN OR SERVICE THE GAS PRESSURE REGULATOR.**

## PILOT SERVICE

If pilot flame burns yellow, clean pilot to ensure a steady blue flame. This can be cleaned by washing in a solvent and/or blowing out with air.

Adjustment of pilot valve is located on the manifold behind the control panel. Clockwise is off, counterclockwise is on. Flame height should be approximately 1/2".

## BURNER VALVE

If burner valve becomes too difficult to turn:

1. Turn off gas to the unit.
2. Remove knobs and control panel.
3. Lift burner out.
4. Loosen nut on front of valve and remove stem.
5. Lubricate the valve stem with high temperature grease.
6. Reassemble.

Upon completion, turn gas on and check for

leaks. The valve should be turned on and off several times to seat correctly.

## BURNER BOX

For removal of burner box, contact the factory.

## REMINDERS

- Be sure you clean both sides of your cooking grate regularly, for efficient fat drain off. Remember, raising the cooking grates changes the temperature only slightly, but drains excess fat more quickly.
- Be sure your broiler burner valves are properly adjusted to achieve a 550°F - 650°F broiling surface. **Do not over fire** as you will cause premature component failure.
- Be sure to inspect and clean the perforated screens regularly to reduce flare-up.
- Be sure to keep the radiant reflectors and heat shields clean on low-profile counter models to reduce flare-up.

# ORIFICE SIZE CHART - DRILL SIZE

**NOTE:** Orifice size may vary depending on country of destination and/or elevation.

UF & UFS		
Nat. 6.0 W.C. (14.94 mbar)	Orifice #48	Part Number <a href="#">6381-9</a>
LP 10.0 W.C. (24.90 mbar)	Orifice #55	Part Number <a href="#">2138-5</a>
UFLC		
Nat. 6.0 W.C. (14.94 mbar)	Orifice #49	Part Number <a href="#">2278-0</a>
LP 10.0 W.C. (24.90 mbar)	Orifice #56	Part Number <a href="#">2245-4</a>

# EXPLODED VIEW

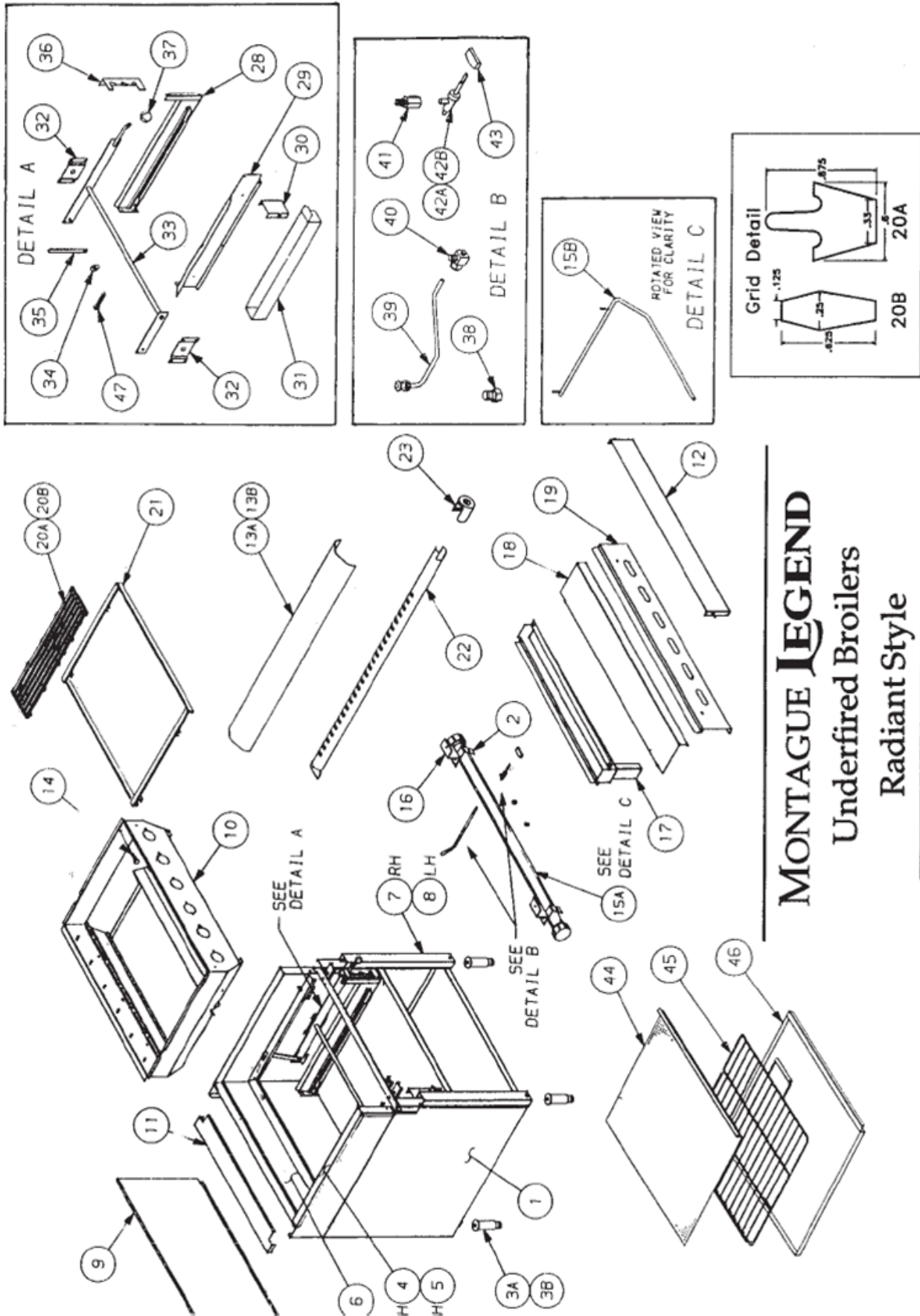

# UF & UFS (RADIANT) EXPLODED VIEW PARTS LIST

ITEM #	DESCRIPTION	24" UNIT	30" UNIT	36" UNIT
1	CABINET BASE	N/A	N/A	N/A
2	BRKT, VALVE	6137-9	6137-9	6137-9
3	LEG W/ FOOT	28441-6	28441-6	28441-6
4	TRIM ASSY, TOP LT (SS)	19413-1	19413-1	19413-1
5	TRIM ASSY, TOP RT (SS)	19412-3	19412-3	19412-3
6	TRIM REAR, TOP (SS)	20371-8	20422-6	19409-3
7	TRIM MULLION, RT	19878-1	19878-1	19878-1
8	TRIM MULLION , LT	19881-1	19881-1	19881-1
9	OUTER PANEL, BACK			
10	BURNER BOX ASSY.	20483-8	20716-0	20110-3
11	COVER , DEBRIS REAR	20793-4	20730-6	20332-7
12	DEFLECTOR, DOOR	20934-1	20933-3	20932-5
13A	RADIANT (SS)	20122-7	20122-7	20122-7
13B	RADIANT (CAST IRON)	20531-1	20531-1	20531-1
14	SCREW, CAP W/ SHANK	19847-1	19847-1	19847-1
15A	MANIFOLD	20239-8	20430-7	20006-9
15B	REAR CONNECTION, MANIFOLD	20466-8	20466-8	20466-8
15C	MANIFOLD W/ REAR CONN UFS	20138-3	20297-5	19352-6
16	SUPPORT BRKT.	19839-0	19839-0	19839-0
17	BROILER TROUGH	20243-6	20374-2	19858-7
18	GUARD RAIL	20248-7	20363-7	20010-7
19	CONTROL PANEL	20474-9	20721-7	20007-7
20A	TOP GRID (ULTRA FLOW)	19692-4	19692-4	19692-4
20B	TOP GRID (NARROW RIB)	9347-5	9347-5	9347-5
21	GRID FRAME ASSY.	20258-4	20347-5	19852-8
22	BURNER	20486-2	20486-2	20486-2
23	AIR SHUTTER	N/A	N/A	N/A
28	LINER, WARMING SHELF - RT	19728-9	19728-9	19728-9
29	LINER, WARMING SHELF - LT	19735-1	19735-1	19735-1
30	BRKT, MOUNTING	19738-6	19738-6	19738-6
31	CONTAINER, GREASE	19752-1	19752-1	19752-1
32	BRKT, LEVER MTG (X2)	19366-6	19366-6	19366-6
33	LEVER ASSY, GRATE	20234-7	20411-0	19363-1
34	WASHER, FLAT	1924-0	1924-0	1924-0
35	VERTICAL LINK	19374-7	19374-7	19374-7
36	BRKT, GRID ADJUSTMENT	19726-2	19726-2	19726-2

## UF & UFS (RADIANT) EXPLODED VIEW PARTS LIST

ITEM #	DESCRIPTION	24" UNIT	30" UNIT	36" UNIT
37	KNOB, BLACK OVAL	22269-0	22269-0	22269-0
38	PLUG, PIPE (BR)	1279-3	1279-3	1279-3
39	LIGHTER, PILOT	20535-4	20535-4	20535-4
40	VALVE, PILOT	1055-3	1055-3	1055-3
42A	VALVE ASSY, BURNER (NAT)	25549-1	25549-1	25549-1
42B	VALVE ASSY, BURNER (LP)	1003-0	1003-0	1003-0
43	HANDLE, VALVE	38485-2	38485-2	38485-2
44	SCREEN, DEBRIS	20564-8	20582-6	20585-0
45	RACK, WIRE W/ HANDLE	20260-6	20259-2	19759-9
46	CONTAINER, DRIP W/ SS TRIM	20253-3	20379-3	19747-5
47	PIN, COTTER	1931-3	1931-3	1931-3
48A	REGULATOR, PRESSURE (NAT)	14605-6	14605-6	14605-6
48B	REGULATOR, PRESURE (LP)	1040-5	1040-5	1040-5

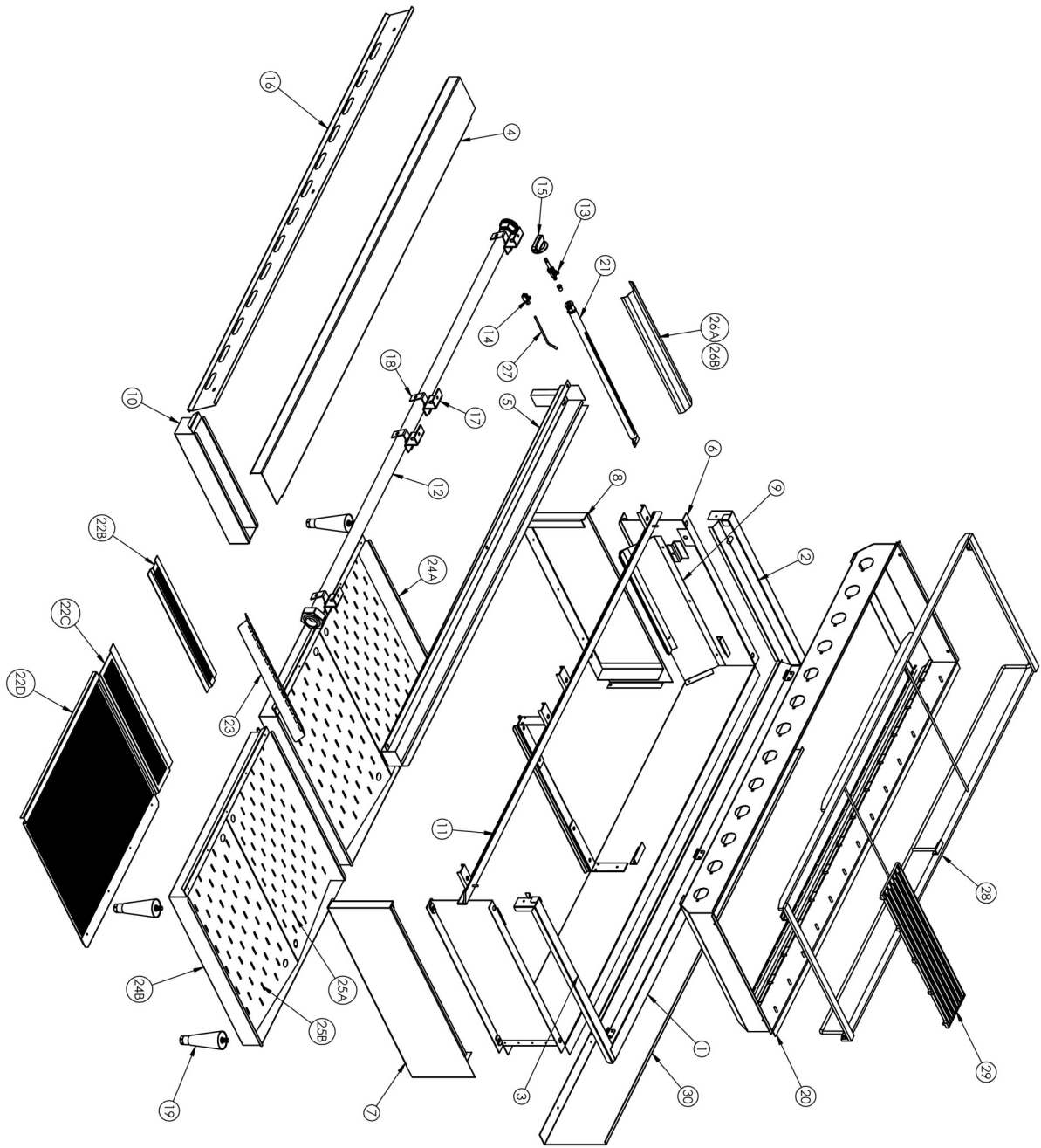

**MONTAGUE LEGEND**  
 LOW PROFILE COUNTER  
 UNDERFIRED BROILERS

## UFLC EXPLODED VIEW PARTS LIST

ITEM #	DESCRIPTION	18" UNIT	24" UNIT	30" UNIT	36" UNIT
1	TRIM, TOP-REAR (SS)	44364-6	21756-5	21753-0	21507-4
2	TRIM, TOP-LEFT (SS)	21085-4	21085-4	21085-4	21085-4
3	TRIM, TOP-RIGHT (SS)	21086-2	21086-2	21086-2	21086-2
4	RAIL, GUARD ASSY.	44352-2	20248-7	20363-7	20010-7
5	TROUGH, BROILER	44349-2	21740-9	21739-5	21532-5
6	INNER PANEL ASSY.	44333-6	22096-5	22095-7	20744-6
7	PANEL,SIDE - RT ASSY.	20719-5	20719-5	20719-5	20719-5
8	PANEL,SIDE - LT ASSY.	20720-9	20720-9	20720-9	20720-9
9	ENCLOSURE, GREASE CONTAINER	20978-3	20978-3	20978-3	20978-3
10	CONTAINER, GREASE	20965-1	20965-1	20965-1	20965-1
11	FRAME, FRONT ASSY.	44324-7	20077-8	20409-9	19387-9
12	MANIFOLD	44336-0	20239-8	20430-7	20006-9
13	VALVE ASSY, BURNER	25549-1	25549-1	25549-1	25549-1
14	VALVE, PILOT	1055-3	1055-3	1055-3	1055-3
15	HANDLE, VALVE W/ SET SCREW	38485-2	38485-2	38485-2	38485-2
16	PANEL, CONTROL	44388-3	20474-9	20721-7	20007-7
17	BRKT,GUARDRIAL SUPPORT	19839-0	19839-0	19839-0	19839-0
18	BRKT, VALVE	6137-9	6137-9	6137-9	6137-9
19	LEG W/ FOOT	28993-0	28993-0	28993-0	28993-0
20	BURNER BOX ASSY.	44320-4	21736-0	21724-7	20811-6
21	BURNER	20486-2	20486-2	20486-2	20486-2
22	SCREEN, DEBRIS	44360-3	20564-8	20585-6	20585-0
23	REFLECTOR, RADIANT	21455-8	21455-8	21455-8	21455-8
24	CONTAINER, DRIP W/ SS TRIM	44385-9	41810-2	41807-2	41796-3
25	HEAT, SHIELD	55615-7	45752-3	21427-2	21429-9
26A	RADIANT, CAST IRON	20531-1	20531-1	20531-1	20531-1
26B	RADIANT, (SS)	20122-7	20122-7	20122-7	20122-7
27	LIGHTER, PILOT	20535-4	20535-4	20535-4	20535-4

# UFLC EXPLODED VIEW PARTS LIST

ITEM #	DESCRIPTION	18" UNIT	24" UNIT	30" UNIT	36" UNIT
28	GRID FRAME ASSY.	44341-7	21993-2	21992-4	21408-6
29	GRID, TOP	19692-4	19692-4	19692-4	19692-4
29A	GRID, TOP (NARROW)	9347-5	9347-5	9347-5	9347-5
30	OUTER PANEL, BACK	24579-8	21710-7	21711-5	21502-3

**NOTE:** Part numbers provided are for 18" to 36" units. Please contact The Montague Company's Parts and Service Dept. to verify part numbers for additional models.

## WARNING

**If not installed, operated and maintained in accordance with the manufacturer's instructions, this product could expose you to substances in fuel or in fuel combustion which can cause death or serious illness and which are known to the State of California to cause cancer, birth defects or other reproductive harm.**

The State of California enacted the California Safe Drinking Water and Toxic Enforcement Act of 1986, (Prop. 65), which "prohibits any person in the course of doing business from knowingly and intentionally exposing any individual to a chemical known to the State of California to cause cancer or reproductive toxicity without first giving clear and reasonable warning to such individuals." The Governor's Scientific Advisory Panel added carbon monoxide to the list of hazardous chemicals known to cause reproductive harm.

In order to establish full compliance with Proposition 65, we attached a yellow warning label to each gas fired unit manufactured by the Montague Company.

Carbon monoxide would not be present in concentrations that would pose a "significant risk" to the consumer when the equipment is installed, operated and maintained as follows:

1. Installed in accordance with all local codes, or in the absence of local codes, with the current National Fuel Gas Code Z223.1.
2. Installed under a properly designed and operating exhaust hood.
3. Connected to the type of gas for which the unit is equipped.
4. Proper appliance pressure regulator installed on the gas supply line and adjusted for the manifold pressure marked on the rating plate.
5. Adequate air supply to the unit.
6. The equipment is operated in the manner intended using the proper utensil for that type of appliance.
7. Keep the equipment clean and have it checked periodically.
8. Burner air adjustments, mechanical maintenance and repairs should be performed by qualified service personnel.

If the equipment is not installed, operated and maintained in accordance with the above, concentrations of carbon monoxide in excess of the established limits could present in the kitchen environment.

ALL PERSONNEL IN THE WORKPLACE WHO MAY BE SUBJECT TO ANY EXPOSURE OF CARBON MONOXIDE MUST BE WARNED OF SUCH POSSIBLE EXPOSURE. THIS WARNING SHOULD BE CONVEYED IN A MANNER SO THAT IT IS CLEARLY UNDERSTOOD BY THE EMPLOYEE, AND THE EMPLOYEE SHOULD BE ASKED IF IN FACT HE OR SHE UNDERSTANDS THE CORRECT METHOD OF OPERATION OF THE EQUIPMENT AND THAT A RISK OF EXPOSURE EXISTS IF THE EQUIPMENT IS OPERATED IMPROPERLY.



**The MONTAGUE COMPANY**

1830 Stearman Avenue, P.O. Box 4954 Hayward, CA 94540-4954

When ordering parts, to eliminate mistakes and facilitate deliver, always give the following information:

Serial No. \_\_\_\_\_

Model No. \_\_\_\_\_

Change No. \_\_\_\_\_

**Name and Number of Part**

<b>Model No.</b>	<b>Change No.</b>	<b>Serial No.</b>	
------------------	-------------------	-------------------	--