

INSTRUCTION MANUAL

INSTALLATION / OPERATIONS / PARTS & SERVICE



Radiglo Gas Fired Heavy Duty Over Fired Broilers



36W36	243W36
43W36	C36
136W36	C45
V136W36	C36 SHB
236W36	C45 SHB

NOTICE

This Manual is prepared for the use of Service Technicians and should not be used by those not properly qualified. This manual is not intended to be all encompassing. You should read, in its entirety, the repair procedure you wish to perform to determine if you have the necessary tools, instruments and skills required to perform the procedure.

RETAIN THIS MANUAL FOR FUTURE REFERENCE.

THE MONTAGUE COMPANY

1830 Stearman Avenue P.O. BOX 4954
HAYWARD, CA 94549-4954
510.785.8822 FAX: 510-785-3342
1-888-875-2722

WWW.MONTAGUECOMPANY.COM

IMPORTANT FOR YOUR SAFETY

THIS MANUAL HAS BEEN PREPARED FOR PERSONNEL QUALIFIED TO INSTALL GAS EQUIPMENT, WHO SHOULD PERFORM THE INITIAL FIELD START-UP AND ADJUSTMENTS OF THE EQUIPMENT COVERED BY THIS MANUAL.

Qualified installation personnel are individuals, a firm, corporation, or company which either in person or through a representative are engaged in and are responsible for:

- A. The installation or replacement of gas piping or the connection, installation, repair or servicing of equipment, who is experienced in such work familiar with all precautions required, and have complied with all requirements of state or local authorities having jurisdiction. reference: National Fuel Gas Code, ANSI Z223.1, section 1.4, latest addenda.
- B. The installation of electrical wiring from the electric meter, main control box or service outlet to the electric appliance. Qualified installation personnel must be experienced in such work, be familiar with all precautions required and have complied with all requirements of state and local authorities having jurisdiction. Reference: National Electric Code, ANSI / NFPA No. 70, latest addenda.

THE BROILER(S) MUST BE INSTALLED IN ACCORDANCE WITH LOCAL CODES, OR IN THE ABSENCE OF LOCAL CODES, WITH THE NATIONAL FUEL GAS CODE, ANSIZ223.1 LATEST ADDENDA, INCLUDING:

The appliance and its individual shutoff valve must be disconnected from the gas supply piping system during any pressure testing of that system at test pressures in excess of 1/2 psig (3.45 kPa).

The appliance must be isolated from the gas supply piping system by closing its individual manual shutoff valve during any pressure testing of the gas supply piping system at test pressures equal to or less than 1/2 psig (3.45 kPa)

POST IN A PROMINENT LOCATION THE INSTRUCTIONS TO BE FOLLOWED IN THE EVENT THE SMELL OF GAS IS DETECTED. THIS INFORMATION CAN BE OBTAINED FROM THE LOCAL GAS SUPPLIER.

IN THE EVENT OF A POWER FAILURE, DO NOT ATTEMPT TO OPERATE THIS DEVICE.

IMPORTANT

IN THE EVENT A GAS ODOR IS DETECTED, SHUT DOWN UNITS AT MAIN SHUTOFF VALVE AND CONTACT THE LOCAL GAS COMPANY OR GAS SUPPLIER FOR SERVICE.

FOR YOUR SAFETY

DO NOT STORE OR USE GASOLINE OR OTHER FLAMMABLE VAPORS OR LIQUIDS IN THE VICINITY OF THIS OR ANY OTHER APPLIANCE.

WARNING

IMPROPER INSTALLATION, ADJUSTMENT, ALTERATION, SERVICE OR MAINTENANCE CAN CAUSE PROPERTY DAMAGE, INJURY OR DEATH. READ THE INSTALLATION, OPERATING AND MAINTENANCE INSTRUCTIONS THOROUGHLY BEFORE INSTALLING, SERVICING OR OPERATING THIS EQUIPMENT.

INTRODUCTION

GENERAL

The Gas Broilers covered in this manual are manufactured for use with the type of gas indicated on the nameplate. Some models include a cabinet, conventional oven, or convection oven.

Montague Gas Broilers are produced with the best possible material and workmanship. Proper installation is essential for safe, efficient, trouble-free operation.

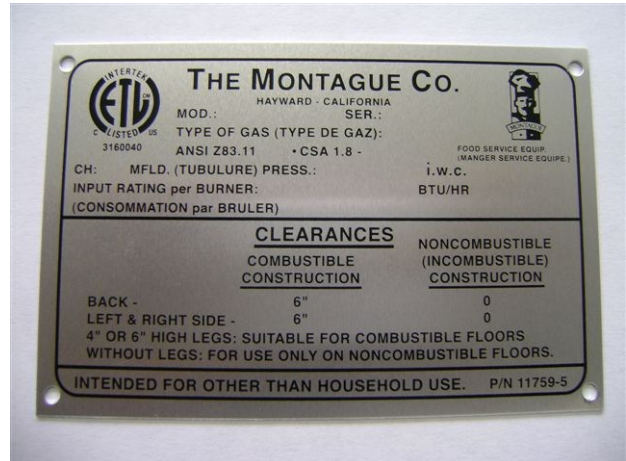

FIGURE1. TYPICAL I.D. PLATE

MODELS

MODEL	CONSISTS OF
36W36	Cabinet Based Broiler with Warming Oven
43W36	Cabinet Based Broiler with Warming Oven
136W36	Broiler with Conventional Oven and Warming Oven
V136W36	Broiler with Convection Oven
236W36	Double Broiler
243W36	Double Broiler
C36	Broiler Only
C45	Broiler Only

SERIAL NUMBER LOCATION

Always have the serial number of your unit available when calling for parts and service. The serial number is on the nameplate that also includes the model number. A typical identification plate is shown in Figure 1.

RECEIVING & INSPECTING THE EQUIPMENT

Care should be taken during unloading so the equipment is not damaged while being moved into the building.

1. Visually inspect the exterior of the package and skid or container. Any damage should be noted and reported to the delivering carrier immediately
2. If damaged, open and inspect the contents with the carrier.
3. In the event that the exterior is not damaged, yet upon opening, there is concealed damage to the equipment, notify the carrier. Notification should be made verbally as well as in written form.
4. Request an inspection by the shipping company of the damaged equipment. This should be done within 10 days from receipt of the equipment.
5. Freight carriers can supply the necessary damage forms upon request.
6. Retain all shipping materials until an inspection has been made or waived.

INTRODUCTION

SPECIFICATIONS

MODEL	# BURNERS (broilers only)	NATURAL BTU/HR	PROPANE BTU/HR	TOTAL BTU/HR
36W36	2	42,000 ea.	42,000 ea.	84,000
43W36	3	42,000 ea.	42,000 ea.	126,000
136W36	2	42,000 ea.	42,000 ea.	124,000
V136W36	2	42,000 ea.	42,000 ea.	129,000
236W36	4	42,000 ea.	42,000 ea.	168,000
243W36	6	42,000 ea.	42,000 ea.	252,000
C36	2	42,000 ea.	42,000 ea.	84,000
C45	3	42,000 ea.	42,000 ea.	126,000

Manifold Pressure

Natural Gas: 6.0"W.C.
Propane Gas: 10.0"W.C.

Gas Inlet Size:
3/4" NPT at lower left rear (all models)

Orifices

Fixed for specified gas type.

Natural Gas: #33 DMS
Propane Gas: #48 DMS

TABLE OF CONTENTS

INSTALLATION

CLEARANCES.....	1
VENTILATING HOOD.....	1
ASSEMBLY.....	1
LEGS.....	1
CERAMIC RADIANTS.....	1
LEVELING.....	2
FLOOR INSTALLATION.....	2
CURB INSTALLATION.....	2
GAS CONNECTION.....	3
GAS PRESSURE REGULATOR.....	3
GAS PRESSURE REGULATOR.....	4
PILOT.....	5
BURNER.....	5

OPERATION

OPERATING CONTROLS.....	6
BURNER CONTROL.....	6
GRID HEIGHT.....	6
GAS CONTROLS (LIGHTING PILOT).....	6
GAS CONTROLS (BURNER VALVE SHUTOFF).....	6

MAINTENANCE

GENERAL CLEANING.....	7
PAINTED SURFACES.....	7
EXTERIOR.....	7
INTERIOR.....	7
STAINLESS STEEL SURFACES.....	7
REMOVE HEAT TINT.....	8
MAINTENANCE SCHEDULE.....	9

PARTS REMOVAL AND REPLACEMENT PROCEDURES

COVER & PANELS.....	10
VENTURI COVER.....	10
CONTROL PANEL COVER.....	10
DRIP DEFLECTOR.....	10
DRIP TRAY AND HORIZONTAL GREASE CONTAINER.....	11
PILOT.....	11
PILOT ASSEMBLY & ORIFICE.....	11
BURNER.....	12
BURNER ASSEMBLY.....	12
BURNER ORIFICE.....	12
BURNER VENTURI.....	12
BURNER VALVES.....	13
CARRIAGE POSITION HANDLE.....	14
BLACK BALL.....	14
CHROME SLEEVE.....	14
THREADED STUD.....	14
GEAR & TUBE ASSEMBLY.....	14
COMPRESSION SPRING.....	14
GEAR & BRACKET.....	15
ADJUSTMENTS.....	16
PRESSURE REGULATOR.....	16
PILOT BURNER.....	16
CARRIAGE POSITION HANDLE.....	17
HANDLE TENSION.....	17
CARRIAGE TENSION SPRING.....	17
TROUBLESHOOT CHART.....	18
TROUBLESHOOT CHART.....	19
C36 & C45 EXPLODED VIEW.....	20
C36 & C45 PART NUMBERS.....	21
C36 & C45 PART NUMBERS.....	22
36W36 & 43W36 EXPLODED VIEW.....	23
36W36 & 43W36 PART NUMBERS.....	24
36W36 & 43W36 PART NUMBERS.....	25

INSTALLATION

CAUTION

Provisions must be made to assure adequate air supply to unit for proper burner operation.

CLEARANCES

The following are minimum clearances from combustible and noncombustible materials.

Location	Combustible Construction	Noncombustible Construction
Back Wall	6"	0"
Left Side	6"	0"
Right Side	6"	0"

With 6" legs: Suitable for installation on combustible floors.

Without legs: For use with special insulated base on noncombustible floors only.

VENTILATING HOOD

The broiler(s) must be installed under a properly designed ventilating hood. The hood should extend at least 6" beyond all sides of the unit. The hood should be connected to an adequate mechanical exhaust system.

Information on construction and installation of ventilating hoods may be obtained from the "Standard for the Installation of Equipment for the Removal of Smoke and Grease Laden Vapors from Commercial Cooking Equipment", NFPA No. 96-1987, available from the National Fire Protection Association, Batterymarch Park, Quincy, Ma. 02269.

It is also necessary that sufficient room air ingress be allowed to compensate for the amount of air removed by the ventilating system. Otherwise, a subnormal atmospheric pressure will occur which may interfere with burner performance or may extinguish the pilot flame. In case of unsatisfactory broiler performance, check with the exhaust in the "Off" position.

ASSEMBLY

Uncrate broiler as near to final location as possible. For easier and lighter handling of broiler, remove grids, grid frame, drip tray and grease container. Remove all packing materials and accessories from broiler interior.

Legs

Some broilers are mounted on legs.

1. Screw the legs into the modular stand.
2. Tightly screw the complete leg assembly into the mounting holes in the bottom of the broiler at each corner. If the unit is intended for curb installation, no legs are provided. The curb must be noncombustible material.

Ceramic Radiants

Ceramic radiants, Figure 2, are located on each side of the burners. Ceramic end pieces are installed at both ends of each burner assembly. Five (5) ceramic radiants are installed on each side of each burner with the pointed side facing down and the holes facing up. Figure 3

TOP VIEW

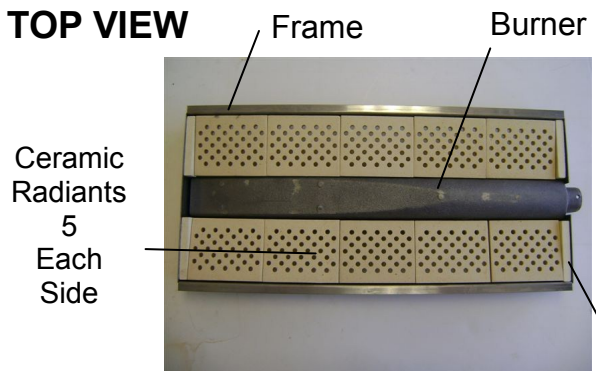

FRONT VIEW



FIGURE 2.

INSTALLATION

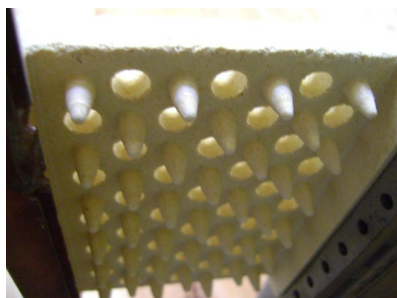

Figure 3. Ceramic Radiants

1. Insert ceramic end pieces at front and rear of the burner frame. Four (4) are required for each burner.
2. Tilt ceramic radiants sideways to clear burner and frame assembly, then lower radiant into position with one flange resting on burner ledge and one flange resting on frame edge.
3. Install the remaining ceramic radiants so that five (5) ceramic radiants are located on each side of the burner.

LOCATION

Adequate clearance for service and proper operation must be provided at the front, top, sides, and back. The combustion air openings are provided in the front of the unit and must not be obstructed.

LEVELING

After broiler is positioned, check that appliance is level both side-to-side and front - to-back.

BATTERY ARRANGEMENT

Setting In Place

Model No's 36W36, 43W36, 136W36, and V136W36.

Floor Mounted Ranges

1. Place the first unit in the exact position it will occupy in the battery.
2. Using a carpenter's level, level the unit front-to rear and side –to– side. **AN UNLEVELED UNIT WILL ADVERSELY AFFECT PERFORMANCE.** Adjust as follows:

FLOOR INSTALLATION ON LEGS: Level by turning foot on leg.

CURB INSTALLATION: Place shim under the low side. This operation is important since variations in floors and curbs are common. Unless units are level, aligning the gas supply manifold will be difficult and the units will not fit together tightly.

3. Remove the valve panel from the broiler.
4. Move the unit into position.
5. Engage union nut on manifold with male fitting on next unit and draw up union nut hand tight. Be sure appliances meet together both front and rear. If manifolds do not align, then units are not level. In extreme cases it may be necessary to loosen manifold bolts and adjust.
6. Continue leveling and connecting gas supply manifolds together until all appliances in battery are connected.
7. Tighten manifold gas union. Use backup wrench to prevent manifold from rotating. **FAILURE TO DO THIS MAY RESULT IN DAMAGE TO THE PILOTS AND GAS VALVES.**

INSTALLATION

GAS CONNECTION

Before connecting the broiler(s) to the gas supply line, be sure that all new piping has been cleaned and purged to prevent any foreign matter from being carried into the controls by the gas. In some cases, filters or drops are recommended. A separate gas shutoff valve must be installed upstream from the gas pressure regulator adjacent to the broiler and located in an accessible area.

It is important that adequately sized piping be run directly to the point of connection at the broiler with as few elbows and tees as possible. Consult your local gas company for proper piping size and gas pressure. Each broiler has a 3/4" NPT manifold input located at the lower left rear of the broiler, Figure 4. On dual broilers, each broiler must have a separate regulator.

NOTE: Pipe joint compound or thread sealant that is used should be resistant to action of liquefied petroleum gases.

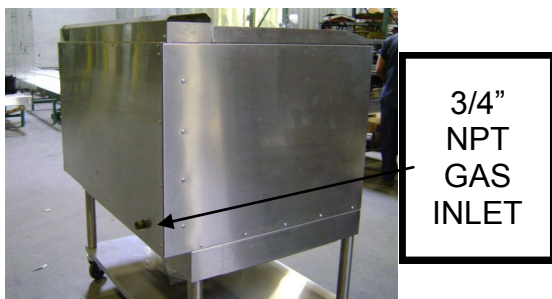

Figure 4. Gas Inlet

Install the gas pressure regulator with gas flowing as indicated by the arrow on the regulator. The arrow must be pointing in toward the unit. Use pipe compound or thread sealant and carefully thread regulator to pipe so that there is no cross threading, etc., which could cause leakage.

1. Apply wrench only to the flat areas around the pipe tapping at the end being threaded to the pipe to avoid possible damage to the regulator body which could result in leakage.

2. Connect the gas supply line from the service gas shutoff valve to the inlet side of the gas pressure regulator using 3/4" pipe. Avoid kinks or sharp bends that could restrict gas flow.

NOTE: If flexible or semi-flexible connectors are used, an AGA listed flexible connector with an I.D. equal to 3/4" pipe must be used.

WARNING

DO NOT USE A DOMESTIC TYPE FLEXIBLE GAS CONNECTOR.

3. Turn gas shutoff valve on and carefully check for gas leaks immediately. Do this before attempting to operate the broiler.

WARNING

TEST ALL PIPE JOINTS FOR LEAKS BEFORE OPERATING BROILER. THIS INCLUDES ALL GAS CONNECTIONS THAT MAY HAVE LOOSENED DURING SHIPMENT. USE A RICH SOAP SOLUTION (OR OTHER ACCEPTED LEAK TESTER) AROUND ALL PIPE JOINTS. DO NOT USE AN OPEN FLAME. ABSOLUTELY NO LEAKAGE SHOULD OCCUR, OTHERWISE THERE IS A DANGER OF FIRE OR EXPLOSION DEPENDING UPON CONDITIONS. DO NOT USE UNIT IF LEAKAGE IS DETECTED.

After piping has been checked for leaks, all piping receiving gas should be fully purged to remove air.

GAS PRESSURE REGULATOR

WARNING

THE BROILER(S) IS/ARE DESIGNED FOR USE WITH A GAS PRESSURE REGULATOR. THE REGULATOR(S) SUPPLIED WITH THIS UNIT MUST BE USED.

FOR NATURAL GAS: This gas pressure regulator is factory adjusted for 6.0" W.C. manifold pressure. The rated inlet pressure to the regulators

INSTALLATION

FOR PROPANE GAS: This gas pressure regulator is factory adjusted for 10.0" W.C. manifold pressure. The rated inlet pressure to the regulator is 1/2 psig (3.45 kPa).

The broiler is equipped with fixed orifices for use with a manifold pressure of 6.0" W.C. for natural gas and 10.0" W.C. for propane gas.

Position the gas pressure regulator outside the broiler as near to the unit as possible.

CAUTION



The gas pressure regulator must be located out of the heat zone to prevent damage to the regulator.

ADJUSTMENT PROCEDURE

WARNING



DO NOT ALLOW UNTRAINED PERSONNEL TO MAINTAIN OR SERVICE THE GAS PRESSURE REGULATOR.

1. Before adjusting the regulator, check the incoming gas line pressure into the regulator. Incoming pressure must be 8.0" W.C. for natural gas, or 14" W.C. for propane gas.
2. If incoming pressure is not correct, have the gas source checked and adjusted.
3. Make sure that the regulator is mounted in the horizontal position with the arrow pointing in the direction of the gas flow.
4. Remove the main burner control valve knobs, Figure 5.



Burner valve knobs

Screws

Figure 5. Control Valve Knobs

5. Remove the control valve panel by removing two screws.
6. Connect a manometer to the pressure tap provided on the broiler unit gas piping manifold, Figure 6.
7. Check the manometer reading. The reading must be 6.0" W.C. for natural gas, or 10.0" W.C. for propane gas.
8. If incoming line pressure is not correct, adjust the regulator. Remove the seal cap on the top of the regulator.
9. Insert a blade-type screwdriver into the top hole of the regulator.
10. Turn the adjust screw clockwise to increase the pressure, or counter clockwise to decrease the pressure .

While watching the manometer, turn the adjustment screw to set proper regulator outlet pressure to the manifold.

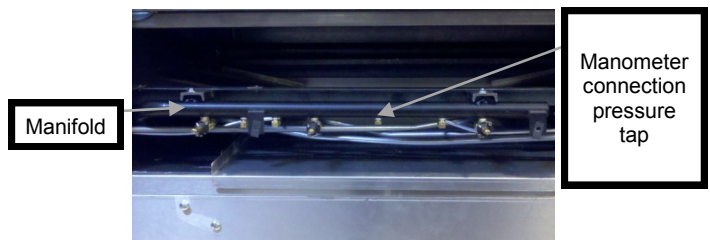

Manifold

Manometer connection pressure tap

Figure 6. Gas Pressure Tap

INSTALLATION

PILOT INITIAL ADJUSTMENT

Each burner has a separate pilot burner. The pilot flame is adjusted through access holes in the valve control panel, Figure 7. Pilot access is through the broiler opening.

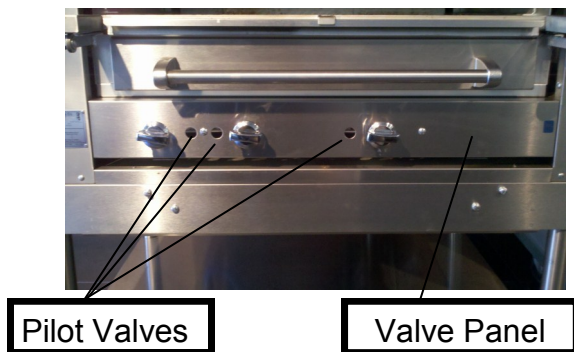

Figure 7. Pilot Valves

1. Turn the main gas shutoff valve to the on position.

NOTE: Pilots are on at all times main shutoff valve is in the on position.

2. Light each pilot.
3. Adjust pilot valve adjustment screw so that each pilot burner has a steady blue flame, Figure 8.

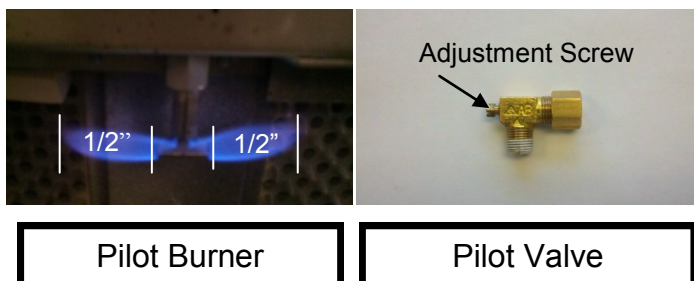

Figure 8. Pilot Burner and Pilot Valve

BURNER ADJUSTMENT

The efficiency of the broiler depends on a delicate balance between the supply of air and the volume of gas at each main burner resulting in complete combustion. Whenever this balance is disturbed, poor operating characteristics occur. An air shutter, Figure 9, on the front of each main burner controls the air supply.

NOTE: Pilots should be lit and properly adjusted before adjusting the main burners.

1. Lift off the manifold cover to access the air shutter for each main burner.
2. Turn on the main burner control valve for the main burner to adjust by rotating the main burner control valve fully clockwise.
3. Increase the air shutter openings until the flame on the burner begins to “lift”. Then close shutter until flame no longer floats, and lock in place. A yellow streaming flame indicates insufficient air. Correct this condition by increasing air shutter opening.

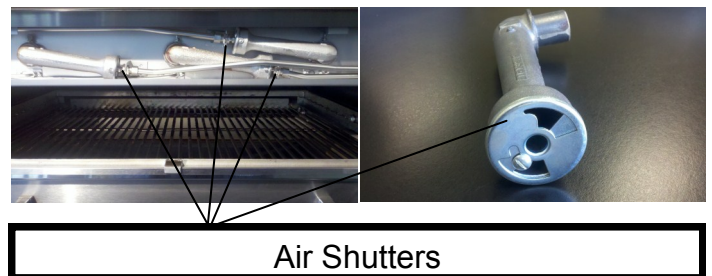

Figure 9. Main Burner Air Shutter

4. After all main burners are properly adjusted, reinstall the manifold cover.
5. Turn all main burner control valves fully counterclockwise to turn the main burner off.

OPERATION

GENERAL

This appliance has been classified as commercial cooking equipment and must be operated by qualified and/or professional operating personnel

WARNING

THE BROILER AND ITS PARTS ARE HOT. USE CARE WHEN OPERATING. CLEANING OR SERVICING THE UNIT.

CAUTION

Do not obstruct the flow of combustion and ventilation air to the broiler. Keep appliance area free and clear of combustibles.

OPERATING CONTROLS

WARNING

IN THE EVENT A GAS ODOR IS DETECTED, SHUT DOWN UNITS MAIN GAS SHUTOFF VALVE AND CONTACT THE LOCAL GAS COMPANY OR GAS SUPPLIER FOR SERVICE..

The following controls are used for operation of the broiler, Figure 10.



Burner Valve Knobs

Grid Height Control

Figure 10. Operating Controls

BURNER CONTROL: Used to turn the gas on or off. One control for each burner.

GRID HEIGHT: The grid is set to the desired cooking height by depressing the ball and adjusting the lever up or down.

Gas Control

Lighting/Relighting Pilot

1. Turn burner valve handle to off position and wait five (5) minutes.
2. Apply lighted match to pilot burner and/or check that pilot is burning.
3. Rotate burner valve handle counterclockwise to the full on position. Burner will ignite automatically.

IMPORTANT: DO NOT THROTTLE THE BURNER DOWN. BURNER MUST OPERATE FULLY OPEN AT ALL TIMES.

4. If pilot becomes extinguished, turn main burner valve to the off position (fully counterclockwise) and wait five (5) minutes before relighting.

Shutdown

1. **Standby:** To turn off, rotate main burner valve handles counterclockwise.
2. **Complete:** Turn all gas main burner valves to off position and turn shutoff valve to broiler to the off position.

IMPORTANT: NEVER THROTTLE THE BURNER DOWN. OPERATE BURNER IN FULL ON POSITION.

Grid Height Adjustment

Depress black ball and move lever up or down to desired cooking height. Figure 10.

MAINTENANCE

GENERAL CLEANING

WARNING

THE BROILER AND ITS PARTS ARE HOT. USE CARE WHEN OPERATING, CLEANING OR SERVICING THE UNIT.

Lint and grease suspended in the air tend to collect in passages. Therefore, air openings, flue ways, and primary air openings, etc., should be periodically cleaned to prevent clogging. The entire broiler should be given a periodic general cleaning.

DAILY

Remove grid racks, drip deflector (below grid rack), drip tray, and grease container. Thoroughly wash with mild detergent or soap. Excessive grease buildup may be removed by using a mildly abrasive cleanser.

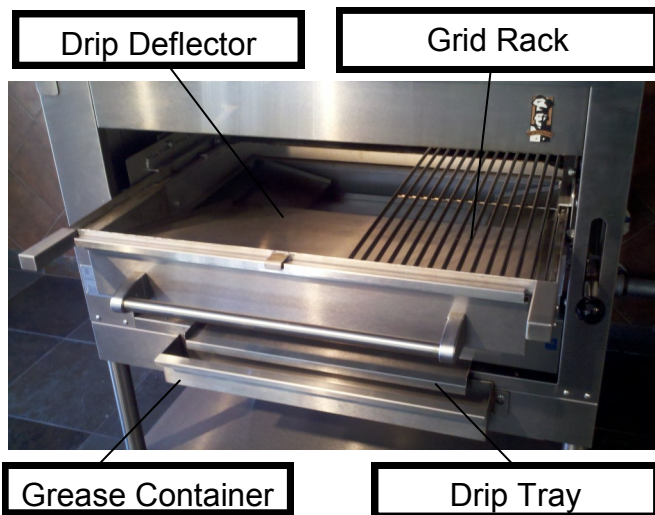

Figure 11. Items To Be Cleaned Daily

PAINTED SURFACES/ POWDER COATED

Exterior

Allow the broiler to cool down before cleaning exterior surfaces. Painted surfaces should be cleaned using a mild soap and warm water solution on a sponge or soft cloth.

Powder Coat, Copper, and other such painted or plated finishes are not covered under warranty. These finishes are subject to wear and may begin to discolor and/or chip within a short period of time. Caution should be taken when cleaning. Using a mild soap and water solution will help to maintain the look and finish.

Interior

Clean interior using a mildly abrasive cleanser with a damp cloth or nylon cleaning pad.

STAINLESS STEEL SURFACES

Stainless steel is an alloy of iron which contains chromium. In the process of manufacturing stainless steel, chromium in the alloy is used to form the hard oxide coating on the surface. If this is taken off through corrosion or wear, it will rust like regular steel.

To remove dirt, grease or product residue from stainless steel, use water and a mild detergent if needed, applied with a sponge or cloth. Dry thoroughly with a clean cloth.

To remove grease and food splatter, or condensed vapors that have baked on the equipment, you can use a (non-abrasive) commercial cream cleanser or baking soda and water, applied with a damp cloth or sponge. Rub cleanser as gently as possible (with the grain) in the direction of the polished lines. **DO NOT RUB IN A CIRCULAR MOTION**, it will damage the finish. Rinse surface after cleaning with a damp cloth and clean water. Dry thoroughly with clean cloth.

MAINTENANCE

Drying thoroughly will prevent water spots which are harmful to the finish.

HELPFUL HINTS:

- To remove streaks, rub stainless steel surface with olive oil.
- To clean and polish, simply moisten a cloth with undiluted white or cider vinegar and wipe clean. Vinegar can also be used to remove heat stains.
- Oil from fingerprints can etch or tarnish stainless steel, especially mirror-polished finishes. Wherever stainless steel is visible, use a glass cleaner to remove fingerprints at the end of the day, before the finish is permanently damaged.

GRIDDLE / PLANCHA

SEASONING:

Seasoning refers to the process of oil or lard being baked into the metal to create a non-stick surface for cooking on a new or recently cleaned griddle. If a griddle has been seasoned and food begins to stick, you should re-season your griddle.

To season follow these steps:

1. Turn griddle on to a low setting (around 300 degrees F) for about 45 mins. to 1 hour.
2. Using a lint-free cotton cloth, apply a generous coat of cooking grade oil or hydrogenated shortening across the entire surface of the griddle. Apply additional layers until surface is slick and oil no longer seeps into griddle.
3. Increase heat on griddle to 350-400 degrees F. Once griddle reaches temp turn griddle off and let cool.
4. Wipe off excess oil with lint-free cotton cloth.

CLEANING:

- After each use, scrape griddle clean with a griddle scraper when cooked food is removed to keep surface free of encrusted material and also prevent flavor transfer.
- After each day, while griddle is warm, clean surface with a griddle stone using a back and forth motion. For stainless steel, rub in the direction of the grain to not damage the surface. Clean grease trough thoroughly and empty grease container.
- Weekly, Allow griddle to cool completely and clean plate with a foodservice grade degreaser. Re-season griddle as needed, or apply a coating of cooking oil to prevent rust.
- A mixture of lemon juice and carbonated (soda) water can also be used while the griddle is warm. After applying mixture, rub griddle stone back and forth to clean surface. Dry thoroughly and re-season if needed, or apply a coating of cooking oil to prevent rust.

*NOTE - See page 9 for complete maintenance schedule of unit.

OVERFIRED BROILER MAINTENANCE SCHEDULE												
COMPONENTS	JAN	FEB	MAR	APRIL	MAY	JUNE	JULY	AUG	SEPT	OCT	NOV	DEC
T-COUPLE (CE)	1,3,4			1,3,4			1,3,4			1,3,4		
INJECTORS	1,2			1,2			1,2			1,2		
GASKETS	1,4			1,4			1,4			1,4		
BEARINGS	1,4			1,4			1,4			1,4		
PILOT	1,2		1,2		1,2		1,2		1,2		1,2	
VALVE (CE)	1,5			1,5			1,5			1,5		
GRID IRON *	2	2	2	2	2	2	2	2	2	2	2	2
BURNERS	1,2				1,2				1,2			
TOP PLATE *	2	2	2	2	2	2	2	2	2	2	2	2
AIR MIXER	1,2			1,2			1,2				1,2	
GREASE CONT. *	2	2	2	2	2	2	2	2	2	2	2	2
INTERIOR	2			2			2				2	
GEAR MECH.	1,5			1,5			1,5				1,5	
REGULATOR	1,2			1,2			1,2				1,2	
CERAMICS	1,2,4			1,2,4			1,2,4				1,2,4	
DRIP TRAY *	2	2	2	2	2	2	2	2	2	2	2	2
1. CHECK												
2. CLEAN												
3. ADJUST												
4. REPLACE												
5. LUBRICATE												
NOTE	Maintenance schedule may vary due to the gas heating value per country.											
NOTE	Lack of maintenance may result in pre-mature failure of components.											
NOTE	Parts marked with an * should be cleaned daily.											

PARTS REMOVAL & REPLACEMENT PROCEDURES

Perform the following procedures to remove and replace parts. To eliminate mistakes when ordering parts, always provide the following information:

- Model Number
- Serial Number

These numbers are located on the nameplate.

CAUTION

 Turn off the broiler gas valve and allow broiler to cool before removing any components

COVER & PANELS

CAUTION

 Turn off the gas supply at the manual shutoff valve that is next to the broiler before attempting to loosen any gas connections.

Venturi Cover

Removal of the venturi cover provides access to the air shutter adjustments and main burner orifices.

1. Remove the two screws under the front edge of the venturi cover.
2. Lift the venturi cover from the broiler.



FIGURE 1. VENTURI COVER

Control Panel Cover

Removal of the control panel cover provides access to the burner valves, pilot adjustment

1. Turn the control valves to the full off position, then remove the control valve knobs.
2. Remove the two screws from the front of the control panel.

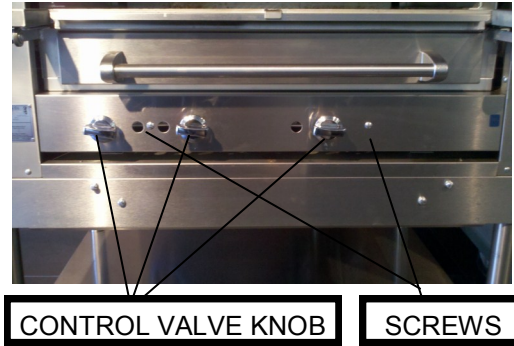

FIGURE 2. CONTROL PANEL COVER

DRIP DEFLECTOR

The drip deflector is located below the grid frame and is angled toward the back of the broiler. Grease dripping onto the drip deflector runs off the back edge to the drip tray then flows forward into the horizontal grease container.

1. Pull the grid frame assembly forward to the stop.
2. Remove the grids from the frame assembly.
3. Lift the back edge of the drip deflector to disengage the drip deflector from the retaining latch.
4. Slide the drip deflector out at a downward angle.
5. When reinstalling the drip deflector, be sure to engage the front end under the retaining latch.

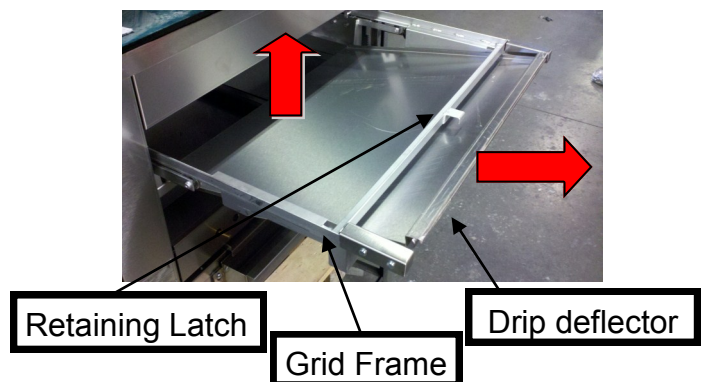

FIGURE 3. DRIP DEFLECTOR

PARTS REMOVAL AND REPLACEMENT PROCEDURES

DRIP TRAY AND HORIZONTAL GREASE CONTAINER

The drip tray is located below the drip deflector. Grease dripping onto the drip deflector runs off the back edge to the drip tray then flows forward into the horizontal grease container.

1. Pull the drip tray straight out the front of the broiler.
2. Lift the horizontal grease container up and away from the broiler.

NOTE: When dumping the contents of the horizontal grease container, be sure to follow appropriate regulations for disposing of grease.



Horizontal Grease Container

Drip Tray

Figure 4. Drip Tray & Grease Container

PILOT

Adjustment Valve

The pilot adjustment valves are located on the manifold behind the control panel cover.



CAUTION

Turn off the gas supply at the manual shutoff valve that is next to the broiler before attempting to loosen any gas connections.

1. Remove the control panel cover as described under Covers and Panels to access the pilot valve.
2. Disconnect the gas line from the back of the valve.
3. Unscrew the pilot valve from the manifold.
4. Install the new pilot valve with the adjustment screw facing the front of the broiler.

NOTE: Make sure that the pipe joint compound or pipe thread sealant that is being used is resistant to the corrosive actions of liquefied petroleum gases.

5. Connect the gas line to the back of the valve.
6. Turn the main gas shutoff valve to broiler to the ON position.



WARNING

ALL GAS JOINTS DISTURBED DURING SERVICING MUST BE CHECKED FOR LEAKS. CHECK WITH A SOAP AND WATER SOLUTION(BUBBLES). DO NOT USE AN OPEN FLAME.

7. Light pilot and adjust pilot valve.
8. Reinstall control panel cover and control valve knobs.



Manifold

Gas Line

Pilot Valve

Figure 5. Pilot Valve

Pilot Assembly and Orifice

The pilot assembly is located adjacent to each burner. The connection for the pilot assembly is accessed by removing the venturi cover.



CAUTION

1. Remove the venturi cover as described in COVERS AND PANELS.
2. Disconnect gas line from back of pilot assembly.
3. Unscrew the two screws attaching the pilot assembly and pilot assembly bracket.

NOTE: Check condition of the pilot orifice and replace if damaged.

PARTS REMOVAL AND REPLACEMENT PROCEDURES

4. Install the new pilot assembly, orifice and pilot assembly bracket.
5. Connect the gas line to the back of the pilot assembly.

NOTE: Make sure that the pipe joint compound or pipe thread sealant that is being used is resistant to the corrosive actions of liquefied petroleum gases.

6. Turn the main gas shutoff valve to the broiler to the ON position.



ALL GAS JOINTS DISTURBED DURING SERVICING MUST BE CHECKED FOR LEAKS. CHECK WITH A SOAP AND WATER SOLUTION (BUBBLES). DO NOT USE AN OPEN FLAME.

7. Light pilot and adjust pilot valve.
8. Reinstall venturi cover, heat shield, insulation and exterior top.

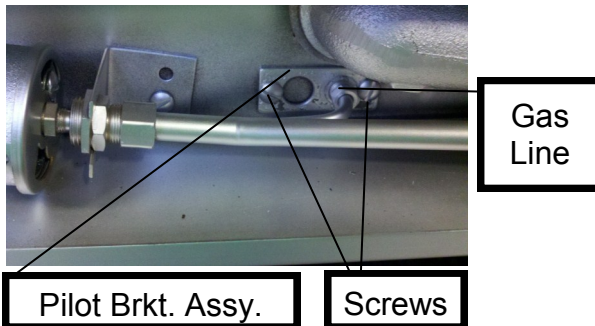

Figure 6. Pilot Assembly Connection

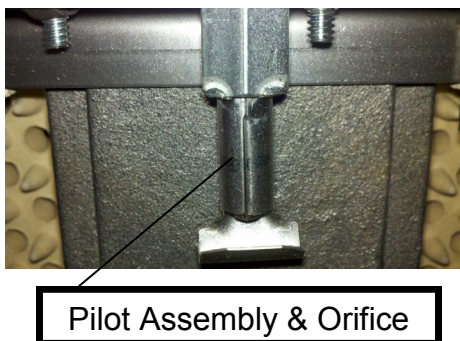

Figure 7. Pilot Assembly

MAIN BURNERS

The connection for the burners is accessed by removing the venturi cover. The burners are accessed by removing the grids and carriage. The burner valves are accessed by removing the control panel cover.



Turn off the gas supply at the main shutoff valve that is next to the broiler before attempting to loosen any gas connections.

Burner Assembly, Orifice and Venturi

1. Remove the venturi cover as described in COVERS & PANELS.
2. Remove the ceramic radiants from each side of the main burner to be replaced.
3. Loosen the set screw that attaches the main burner to the venturi assembly.
4. Slide the main burner out of the broiler.
5. If the venturi or orifice is to be replaced, disconnect the gas input to the venturi. Remove the gasket. Replace the gasket every time the venturi or burner is removed.
6. Loosen the lock nut so that the venturi can be removed from the bracket.

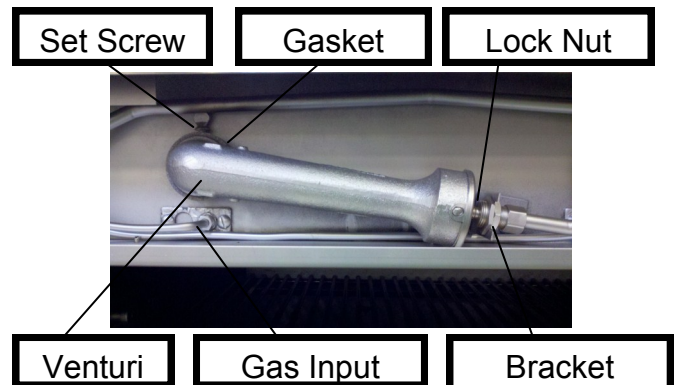

Figure 8. Burner Pilot Assembly

7. Remove the orifice hex nut fitting from the venturi.
8. Remove the orifice from the hex nut fitting.

PARTS REMOVAL & REPLACEMENT PROCEDURE

9. Reassemble by reversing procedure.



ALL GAS JOINTS DISTURBED DURING SERVICING MUST BE CHECKED FOR LEAKS. CHECK WITH A SOAP AND WATER SOLUTION (BUBBLES). DO NOT USE AN OPEN FLAME.

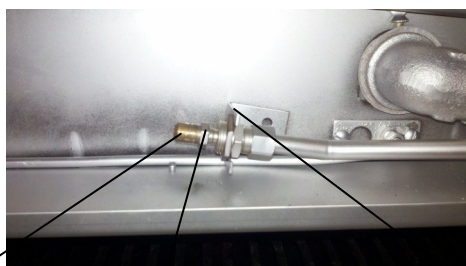

Orifice

Orifice Hex fitting

Bracket

Figure 9. Orifice Assembly

Burner valve

The burner valves are located on the manifold behind the control panel cover.



Turn off the gas supply at the manual shutoff valve that is next to the broiler before attempting to loosen any gas connections.

1. Remove the control panel cover as described under COVERS & PANELS to access the burner valve.
2. Disconnect the gas line from the back of the burner valve.
3. Unscrew the burner valve from the manifold.
4. Install the new burner valve.

NOTE: Make sure that the pipe joint compound or pipe thread sealant that is being used is resistant to the corrosive actions of liquefied petroleum gases.

5. Connect the gas line to the back of the valve.
6. Turn the main gas shutoff valve to the broiler to the "ON" position.



ALL GAS JOINTS DISTURBED DURING SERVICING MUST BE CHECKED FOR LEAKS. CHECK WITH A SOAP AND WATER SOLUTION (BUBBLES). DO NOT USE AN OPEN FLAME.

7. Light pilot.
8. Reinstall the control panel cover and control valve knobs.
9. Turn burner valve full on and check that burner is properly lit.

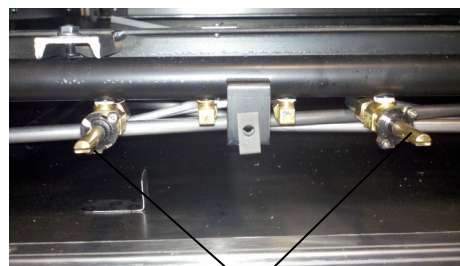

Burner Valves

Figure 10. Burner Valve

PARTS REMOVAL AND REPLACEMENT PROCEDURE

CARRIAGE POSITION HANDLE

The carriage position handle consists of the parts shown in the following illustration and parts list.

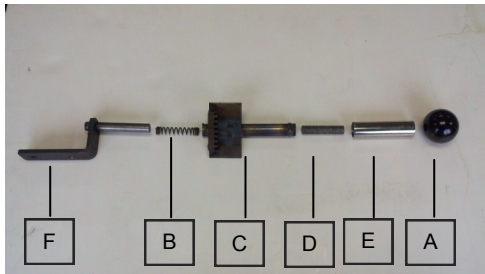

Figure 11. Carriage Position Handle

Item	Part #	Description	Qty.
A	02033-8	Knob, Black Ball	1
B	32756-5	Compression Spring	1
C	03503-3	Gear and Tube Assembly	1
D	03506-8	Stud, Threaded	1
E	03504-1	Sleeve, Chrome	1
F	14442-8	Handle Bracket	1

Black Ball Knob

1. Remove the black ball knob by unscrewing it (counterclockwise) from the threaded stud.
2. Replace the black ball knob by screwing it (clockwise) onto the threaded stud.

Chrome Sleeve

1. Turn off the burners.
2. Allow the broiler to cool to room temperature.
3. Remove the black ball knob by unscrewing it (counterclockwise) from the threaded stud.
4. Remove the sleeve from the tube / threaded stud assembly.
5. Replace the chrome sleeve by placing the sleeve onto the threaded stud.

Threaded Stud

1. Turn off the burners.
2. Allow the broiler to cool to room temperature.
3. Remove the black ball knob by unscrewing it (counterclockwise) from the threaded stud.
4. Remove the chrome sleeve from the tube/ threaded stud assembly.
5. Unscrew the threaded stud from the tube.
6. Reinstall the threaded stud by performing the above steps in reverse order. Screw the threaded stud about 1" into the threaded end of the tube.

Gear and Tube Assembly

1. Turn off burners.
2. Allow the broiler to cool to room temperature.
3. Remove the black ball knob by unscrewing it (counterclockwise) from the threaded stud.
4. Remove the chrome sleeve.
5. Remove gear with bracket from the cabinet frame.
6. Slide the gear and tube assembly off the carriage position handle arm.
7. Replace the gear and tube assembly by performing the above steps in reverse order.

Compression Spring

1. Turn off burners.
2. Allow the broiler to cool to room temperature.
3. Remove the black ball knob by unscrewing it (counterclockwise) from the threaded stud.
4. Remove the chrome sleeve.
5. Remove the threaded rod.
6. Remove the spring from the tube and gear assembly using needle nose pliers.
7. Replace the compression spring by performing the above steps in reverse order.

PARTS REMOVAL AND REPLACEMENT PROCEDURES

Gear with Bracket

1. Turn off the burners.
2. Allow the broiler to cool to room temperature.
3. Raise grill to the top.
4. Remove all components of carriage position handle.
5. Remove the two screws and nuts that hold the gear with bracket to the vertical frame rail.
6. Replace the gear with bracket by performing the above steps in reverse order.

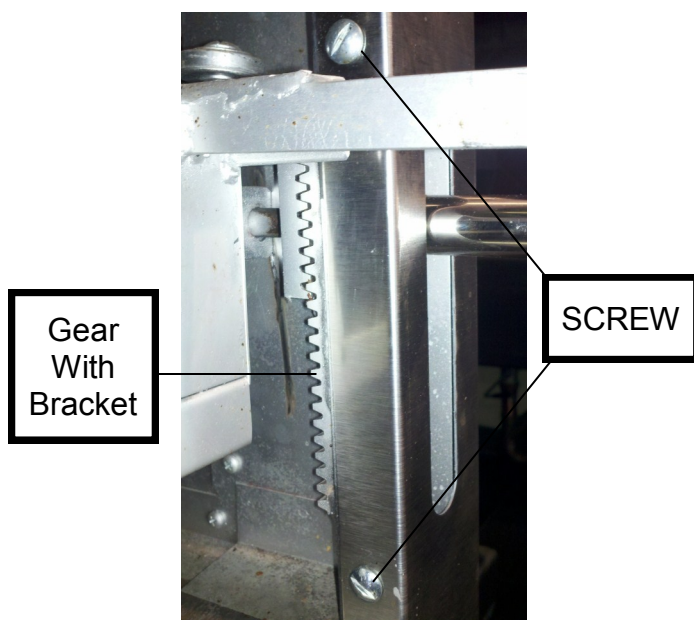

Figure 12. Gear with Bracket Assembly

SERVICE & ADJUSTMENT PROCEDURES

When service is needed, contact a local service company, dealer, or factory to perform mechanical maintenance and repairs. These instructions are intended for use by competent service personnel.

CAUTION

Turn off the gas supply at the manual shutoff valve that is next to the broiler unit before attempting to loosen any gas connections.

GAS PRESSURE REGULATOR ADJUSTMENT PROCEDURE

WARNING

DO NOT ALLOW UNTRAINED PERSONEL TO MAINTAIN OR SERVICE THE GAS PRESSURE REGULATOR.



Figure 13. Gas Pressure Regulator

1. Before adjusting the regulator, check incoming gas line pressure. Incoming pressure before the regulator must be 6.0"W.C. for Natural Gas, or 14.0"W.C. for Propane Gas.
2. If incoming pressure is not correct, have the gas source checked and adjusted as necessary.
3. Make sure that the regulator is mounted in the horizontal position with the arrow pointing in the direction of the gas flow.
4. Connect a monometer to the pressure tap provided on the manifold between the regulator and the burner valves.
5. Check the manometer reading. The reading must be 6.0"W.C. for Natural Gas, or 10.0" W.C. for Propane Gas.
6. If incoming line pressure is not correct, adjust the regulator. Remove seal cap on top of the regulator.

7. Insert a blade-type screwdriver into the top hole of the regulator.
8. Turn the adjustment screw clockwise to increase the pressure, or counterclockwise to decrease the pressure.
9. While watching manometer, turn the adjustment screw to set proper Regulator outlet pressure.

PILOT BURNER ADJUSTMENT PROCEDURE

1. Light the pilot burner as described in the *Installation and Operation Manual*.

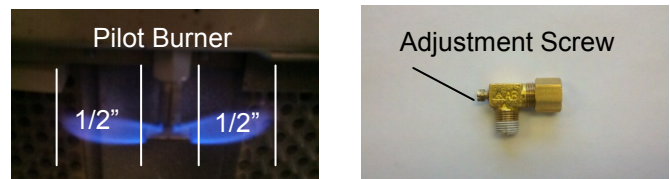

Figure 14. Pilot Burner and Adjustment Valve

2. If the pilot burner flame burns yellow, clean the pilot burner orifice and the pilot burner in order to ensure a steady blue flame. The orifice can be cleaned by washing it in a solvent such as trichloroethylene and/or blowing out with air.
3. If the pilot burner flame still burns yellow, replace the pilot burner orifice.
4. If the pilot flame does not extend 1/2" beyond the outer edges of the pilot shield, or if it extends more than 1/2" beyond the outer edges of the pilot shield, an adjustment is necessary.
5. Remove the control panel cover as described in **COVERS AND PANELS**.
6. Turn the pilot adjustment valve screw until 1/2" flames are observed.

SERVICE AND ADJUSTMENT PROCEDURES

CARRIAGE POSITION HANDLE ADJUSTMENT PROCEDURE

The carriage position handle can be placed in a number of vertical positions.

1. Grasp the black ball knob and press it in toward the front control panel.
2. Raise or lower the carriage assembly to the desired height.
3. Release pressure on the black ball knob to lock the carriage assembly at the desired height.

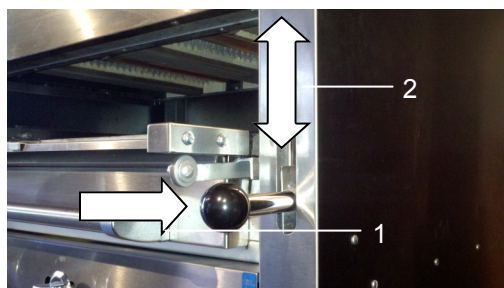

Figure 15. Carriage Position Handle

HANDLE TENSION ADJUSTMENT

If carriage is difficult to move or will not stay in place, the handle tension requires adjusting.

1. Remove black ball knob and chrome sleeve.
2. Turn threaded rod to the left to increase tension; turn to the right to decrease tension.

CARRIAGE TENSION SPRING ADJUSTMENT PROCEDURE

Carriage adjustments should be made with grid irons in place and allowance for product weight.

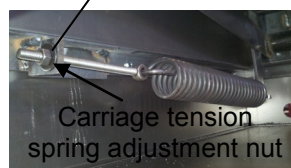
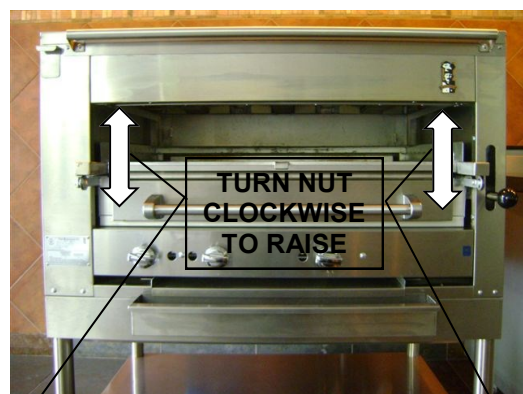

Figure 16. Carriage Tension Spring

1. Locate the carriage tension spring adjustment nut. The adjustment nut is accessible from the front as follows:

Model #'s 36W36 and 43W36:
Through lower compartment.

Model #'s 136W36 and V136W3
Behind Valve Panel

Model #'s C36, C45, 236W36 and 243W36
Behind left and right front panels.

2. Turn nut clockwise to increase tension or counterclockwise to decrease tension.
3. If one side of the grid is lower than the other side, turn the adjustment nut on the low side clockwise to level the grid.

TROUBLESHOOTING CHART

SYMPTOM	CAUSE	REMEDY
Pilot burner flames are burning yellow	Gas too rich	Perform the <i>Pilot Burner Adjustment Procedure</i>
	Clogged pilot air passages	Perform the <i>Pilot Burner Orifice Removal and Replacement Procedure</i> .
	Pilot not properly adjusted	Perform the <i>Pilot Adjustment Valve Adjustment Procedure</i> .
Pilot burner flames are less than or more than 1/2"	Pilot not properly adjusted	Perform the <i>Pilot Burner Adjustment Procedure</i> .
	Clogged pilot burner	Replace pilot burner.
One or more pilot burner flames Cannot be adjusted.	Faulty pilot burner or orifice	Perform the <i>Pilot Burner Removal and Replacement Procedure or Orifice Removal And Replacement Procedure as Applicable</i> .
	Faulty pilot valve	Perform the <i>Pilot Burner Valve Removal and Replacement Procedure</i> .
Burner flames burning yellow	Incorrect gas pressure or secondary air.	Check gas pressure. Adjust or Clean air mixer.
One or more burner flames Cannot be adjusted.	Dirty Venturi passage	Perform the <i>Main Burner Orifice Removal and Replacement Procedure</i>
	Incorrect gas pressure	Check and adjust gas pressure.
	Ceramics cracked, broken or Missing.	Replace damaged or missing Ceramics. See <i>Installation & Operation Manual</i> .
	Faulty burner valve.	Perform the <i>Main Burner Removal and Replacement Procedure</i> .

TROUBLESHOOTING CHART

SYMPTOM	CAUSE	REMEDY
The heat of one or more burners is not uniform over the surface of the ceramic tiles.	Clogged burner ports	Clean burner ports or perform <i>The Main Burner Removal and Replacement Procedure.</i>
	Broken or missing ceramics	Replace broken or missing ceramics.
	Dirty venturi passage	Clean air mixer and venturi.
	Wrong gas pressure	Check and adjust gas pressure.
Carriage assembly will not stay at a set height position.	Improper handle spring tension Adjustment	Perform the <i>Handle Tension Adjustment Procedure.</i>
	Worn or broken gear with bracket	Perform the <i>Gear with Bracket Removal and Replacement Procedure.</i>
Carriage assembly moves up and down too easily or too hard.	Improper carriage spring tension Adjustment.	Perform the <i>Carriage Tension Spring Adjustment Procedure.</i>

C36 & C45 EXPLODED VIEW

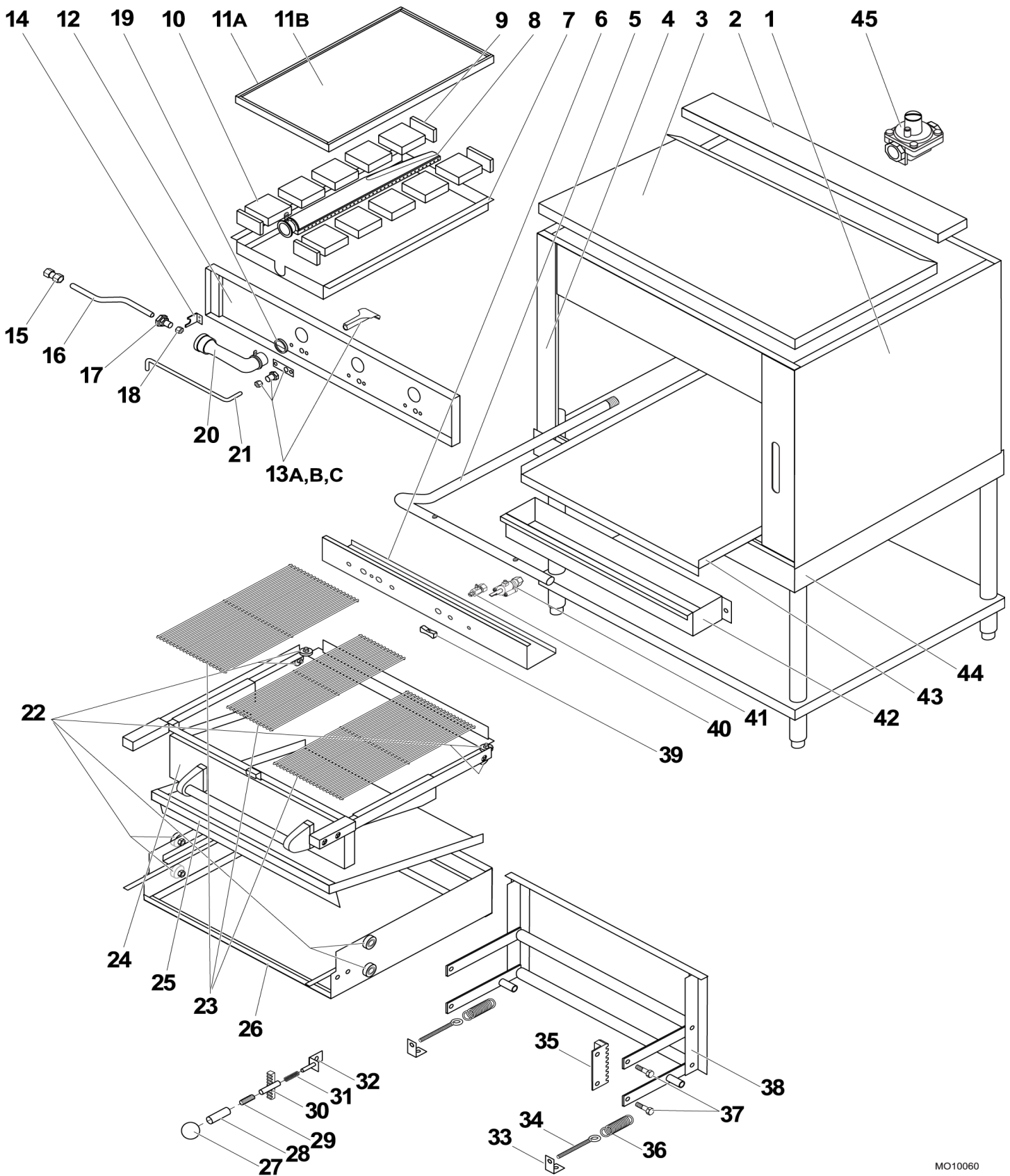

MO10060

ITEM	PART #	PART #	DESCRIPTION
	C36 & 236W36	C45 & 243W36	
1	12925-9	12925-9	PANEL, RIGHT SIDE
2A	25442-8	25442-8	FLUE, RIGHT SIDE
2B	25440-1	25440-1	FLUE, LEFT SIDE
2C	12610-1	15391-5	FLUE DEFLECTOR
3	15355-9	15385-0	EXTERIOR TOP
4	12923-2	12923-2	PANEL, LEFT SIDE
5	1100-2	1100-2	MANIFOLD
6	15367-2	15392-3	VALVE CONTROL PANEL
7	15211-0	15211-0	FRAME, BURNER ASSEMBLY
8	3511-4	3511-4	BURNER W/ SET SCREW
9	11614-9	11614-9	INSULATOR, CERAMIC
10	11611-4	11611-4	CERAMIC, LARGE
10A	28387-8	28387-8	CERAMIC KIT(10 ea. 11611-4) (4 ea. 11614-9)
11A	15352-4	15383-4	HEAT SHIELD
11B	1430-3	1430-3	INSULATION
12	15182-3	15295-1	FIREBOX FRONT ASSEMBLY
13A	11769-2	11769-2	PILOT BURNER HEX COMPRESSION FITTING
13B	2193-8	2193-8	PILOT BURNER ORIFICE—NATURAL
13C	2194-6	2194-6	PILOT BURNER ORIFICE—PROPANE
14	3397-9	3397-9	BRACKET, ORIFICE
15	1280-7	1280-7	UNION, TUBING
16	1252-1	1252-1	TUBING, STEEL
17	6378-9	6378-9	BURNER, ORIFICE HEX COMPRESSION FITTING
18A	4342-0	4342-0	BURNER, ORIFICE— LP #49
18B	17130-1	17130-1	BURNER, ORIFICE— NAT #32
19	20923-6	20923-6	GASKET, VENTURI
20	15216-1	15216-1	VENTURI, AIR MIXER ASSEMBLY
21	1224-6	1224-6	TUBING, ALUMINUM
22	3396-0	3396-0	BEARING, W/ ASSEMBLY

ITEM	PART #	PART#	DESCRIPTION
	C36 & 236W36	C45 & 243W36	
23A	1601-2	1601-2	GRID IRON, LEFT
23B	1600-4	1600-4	GRID IRON, RIGHT
23C	N/A	1602-0	GRID IRON, CENTER
24	38331-7	38040-7	GRID FRAME ASSEMBLY
25	2549-1	3548-3	DRIP DEFLECTOR
26	4655-8	4657-4	CARRIAGE ASSEMBLY
27	2033-8	2033-8	KNOB, BLACK BALL
28	3504-1	3504-1	HANDLE, SLEEVE
29	3506-8	3506-8	THREADED ROD
30	3503-3	3503-3	TUBE AND GEAR ASSEMBLY
31	32756-5	32756-5	SPRING, HANDLE
32	14442-8	14442-8	HANDLE ASSEMBLY BRACKET
33	15244-7	15244-7	CARRIAGE SPRING MOUNTING BRACKET
34	1938-0	1938-0	EYE BOLT
35	3507-6	3507-6	GEAR, W/ ANGLE BRACKET
36	34258-0	2034-6	CARRIAE SPRING
37	28365-7	28365-7	CARRIAGE BOLT
38	13096-6	13101-6	STABILIZER UNIT ASSEMBLY
39	2002-8	2002-8	VALVE HANDLE W/ SET SCREW
40	1000-6	1000-6	VALVE, PILOT
41	1007-3	1007-3	VALVE, BURNER
42A	6604-4	6604-4	HORIZONTAL GREASE CONTAINER-PAINTED
42B	6603-6	6603-6	HORIZONTAL GREAE CONTAINER- STAINLESS STEEL
43	15246-3	15366-4	DRIP TRAY
44	13064-8	13056-6	STAND, MODULAR- PAINTED
45A	14605-6	14605-6	GAS PRESSURE REGULATOR- NATURAL
45B	1040-5	1040-5	GAS PRESSURE REGULATOR- PROPANE

NOTES

36W36 & 43W36 EXPLODED VIEW

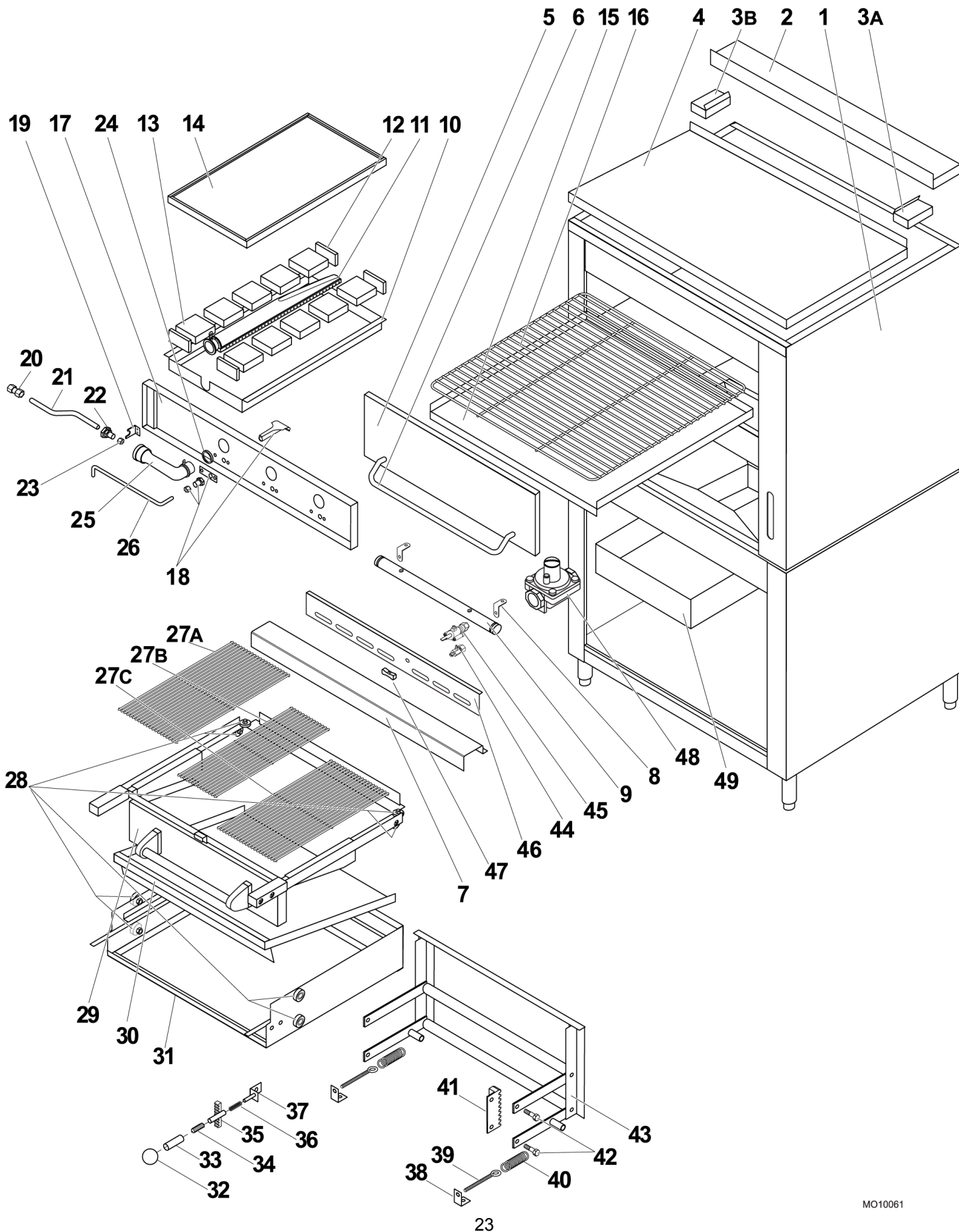

ITEM	PART #	PART #	DESCRIPTION
	36W36	43W36	
1	15168-8	15287-0	PANEL, BACK & SIDE
2	15233-1	32069-2	FALSE TOP, FRONT
3A	15238-2	32075-7	FLUE, LEFT SIDE
3B	15239-0	32076-5	FLUE, RIGHT SIDE
4	15232-3	15232-3	FALSE TOP, FRONT
5	15609-4	31642-3	DOOR ASSEMBLY
6	3173-9	3173-9	HANDLE
7	15187-4	15305-2	GUARD RAIL ASSEMBLY
8	6137-9	6137-9	VALVE BRACKET
9	1073-1	15303-6	MANIFOLD
10	3544-0	3544-0	BURNER FRAME ASSEMBLY
11	3511-4	3511-4	BURNER W/ HARDWARE
12	11614-9	11614-9	CERAMIC INSULATOR
13	11611-4	11611-4	CERAMIC, LARGE
13A	28387-8	28387-8	CERAMIC KIT (4 ea. 11614-9) (10 ea. 11611-4)
14	15359-1	15359-1	HEAT SHIELD
15	15223-4	31645-8	OVEN BOTTOM LINER
16	1604-7	1579-2	WIRE RACK
17	15182-3	15295-1	FIRE BOX FRONT ASSEMBLY
18A	11769-2	11769-2	PILOT BURNER ASSEMBLY– NATURAL
18B	15432-6	15432-6	PILOT BURNER ASSEMBLY– PROPANE
18C	2193-8	2193-8	PILOT ORIFICE– NATURAL
18D	2194-6	2194-6	PILOT ORIFICE– PROPANE
19	3397-9	3397-9	ORIFICE BRACKET ASSEMBLY
20	1280-7	1280-7	UNION, TUBING
21	1252-1	1252-1	TUBING, STEEL
22	6378-9	6378-9	HEX COMPRESSION FITTING ASSEMBLY
23A	6377-0	6377-0	BURNER ORIFICE-NATURAL
23B	2278-0	2278-0	BURNER ORIFICE– PROPANE
24	20923-6	20923-6	GASKET, VENTURI

ITEM	PART #	PART #	DESCRIPTION
	36W36	43W36	
25	15216-1	15216-1	VENTURI
26	1231-9	1231-9	TUBING, ALUMINUM
27A	1601-2	1601-2	GRID IRON- LEFT
27B	N/A	1602-0	GRID IRON- CENTER
27C	1601-2	1601-2	GRID IRON- RIGHT
28	3396-0	3396-0	BEARING ASSEMBLY
29	32376-4	38040-7	GRID FRAME ASSEMBLY WITH BEARINGS
30	3547-5	3548-3	DRIP DEFLECTOR
31	4660-4	4661-2	CARRIAGE ASSEMBLY
32	2033-8	2033-8	KNOB, BLACK BALL
33	3504-1	3504-1	SLEEVE
34	3506-8	3506-8	THREADED ROD
35	3503-3	3503-3	TUBE & GEAR ASSEMBLY
36	23753-1	23753-1	SPRING, HANDLE
37	14442-8	14442-8	HANDLE ASSEMBLY BRACKET
38	15244-7	15244-7	BRACKET, CARRIAGE SPRING
39	1938-0	1938-0	EYE BOLT
40	34258-0	2034-6	CARRIAGE SPRING
41	3507-6	3507-6	GEAR W/ ANGLE BRACKET
42	28365-7	28365-7	CARRIAGE BOLT
43	13108-3	13109-1	STABALIZER UNIT ASSEMBLY
44	1000-6	1000-6	PILOT VALVE
45	1007-3	1007-3	VALVE
46	15267-6	15333-8	PANEL, VALVE CONTROL
47	38485-2	38485-2	HANDLE, VALVE, W/ SET SCREW
48A	14605-6	14605-6	REGULATOR, GAS PRESSURE- NATURAL
48B	1040-5	1040-5	REGULATOR, GAS PRISSURE- PROPANE
49	4291-9	4291-9	GREASE DRAWER, 14" X 26 1/2" X 4

WARNING

If not installed, operated and maintained in accordance with the manufacturers instructions, this product could expose you to substances in fuel or in fuel combustion which can cause death or serious illness and which are known to the State of California to cause cancer, birth defects or other reproductive harm.

The State of California enacted the California Safe Drinking Water and Toxic Enforcement Act of 1986, (Prop. 65), which “prohibits any person In the course of doing business from knowingly and intentionally exposing any individual to a chemical known to the State of California to cause cancer or reproductive toxicity without first giving clear and reasonable warning to such individuals.” The Governor’s Scientific Advisory Panel added carbon monoxide to the list of hazardous chemicals known to cause reproductive harm.

In order to establish full compliance with Proposition 65, we attached a yellow warning label to each gas fired unit manufactured by the Montague Company.

Carbon monoxide would not be present in concentrations that would pose a “significant risk” to the consumer when the equipment is installed, operated and maintained as follows:

1. Installed in accordance with all local codes, or in the absence of local codes, with the current National Fuel Gas Code Z223.1, Latest Addendum.
2. Installed under a properly designed and operating exhaust hood.
3. Connected to the type of gas for which the unit is equipped.
4. Proper appliance pressure regulator installed on the gas supply line and adjusted for the manifold pressure marked on the rating plate.
5. Adequate air supply to the unit.
6. The equipment is operated in the manner intended using the proper utensil for that type of appliance.
7. Keep the equipment clean and have it checked periodically.
8. Burner air adjustments, mechanical maintenance and repairs should be performed by qualified service personnel.

ALL PERSONNEL IN THE WORKPLACE WHO MAY BE SUBJECT TO ANY EXPOSURE OF CARBON MONOXIDE MUST BE WARNED OF SUCH POSSIBLE EXPOSURE. THIS WARNING SHOULD BE CONVEYED IN A MANNER SO THAT IT IS CLEARLY UNDERSTOOD BY THE EMPLOYEE, AND THE EMPLOYEE SHOULD BE ASKED IF IN FACT HE OR SHE UNDERSTANDS THE CORRECT METHOD OF OPERATION OF THE EQUIPMENT AND THAT A RISK OF EXPOSURE EXISTS IF THE EQUIPMENT IS OPERATED IMPROPERLY.



**SAVE THESE INSTRUCTIONS
FOR FUTURE USE.**

The MONTAGUE Company

1830 Stearman Ave. • P.O. Box 4954 • Hayward, CA 94540-4954

Tel: 510/785-8822 • Fax: 510/786-9931

1-888-875-2722

WWW.MONTAGUECOMPANY.COM

P/N 40583-3 RD 4/13