

OWNER'S MANUAL



2424, 121224 AUTOBROIL™

THIS MANUAL APPLIES TO BROILERS WITH S/N 3284 FORWARD

MODEL: 2424 121224 AUTOBROIL™

TABLE OF CONTENTS

I. BROILER SETTINGS	1
II. EQUIPMENT INSTALLATION	2
Pre-Installation	2
Equipment Location	2
Electrical Information	2
III. OPERATING INSTRUCTIONS	3
Pre-Operation Check	3
Broiler Adjustment	3
Toaster Operating Instructions	3-4
Toaster Shut-Off Instructions	4
Toaster Conveyor Speed	4
Operation of 6-Button Controller	5-11
IV. SCHEDULED MAINTENANCE	12
Daily Cleaning Procedures	12-13
Monthly Cleaning Procedures	13
Quarterly Cleaning Procedures and Preventive Maintenance	13-14
V. TROUBLE SHOOTING	14-18
VI. ASSEMBLY & DISASSEMBLY INSTRUCTIONS	18-19
VII. REPLACEMENT PARTS	19-21

ILLUSTRATIONS

Overall Dimensions	Figure 1
Exploded View - Removable Parts	Figure 2
Exploded View - Internal Parts	Figure 3
Exploded View - Drive System	Figure 4
Drive System Detail	Figure 4A
Control Panel With 6-Button Control	Figure 5
Conveyor Axle Scraper	Figure 6
Spark Guard Installation	Figure 7
Broiler Arm Extension 2424	Figure 8
Broiler Arm Extension 121224	Figure 9
Broiler Idler Shaft Asby	Figure 10
Toaster Platen Asby LH	Figure 11
Toaster Platen Asby RH	Figure 12
Speed Control Circuit Board	Figure 13
Fuse Location	Figure 14
Toaster Platen Heat Control	Figure 15
Element Locations	Figure 16
Wiring Schematic 121224	(208V, 3PH, 60 AMP w/6-Button Control) Drawing #145703
Control Panel Quick Guide	Drawing #145747

OWNER'S MANUAL



2424, 121224 AUTOBROIL™

I. BROILER SETTINGS

AUTOBROIL™

MODEL: 2424 121224

MODEL NUMBER: _____

SERIAL NUMBER: _____

ELECTRICAL SUPPLY: _____

SCHEMATIC NUMBER _____ REV. _____

TOASTER PLATEN TEMPERATURE SETTING (425°F IS FACTORY SETTING) _____

MENU SETTINGS:

TEMPERATURE

RECIPE KEY SPEED

TOP

BOTTOM

1 _____
2 _____
3 _____
4 _____
5 _____
6 _____

START-UP TECHNICIAN: _____

START-UP DATE: _____

COMMENTS: _____

OWNER'S MANUAL



2424, 121224 AUTOBROIL™

II. EQUIPMENT INSTALLATION

PRE-INSTALLATION

1. After uncrating the Autobroil™ unit, inspect for shipping damage. Check that the controller, switches, and components are intact on the electrical cabinet front. Set the Autobroil™ in place and use the plastic bag to protect it from the debris and trash of building construction. Check that sideskins have not been dented or damaged by the carrier. If damaged, notify your freight carrier immediately to file a concealed damage claim, following the instructions attached to the outside of the shipping crate. Your warranty will not cover freight damage.
2. Because this unit is required to be power fan exhausted, it is necessary to provide adequate make up air equal to the amount of air removed. In addition to this, any other exhausts, flues, or air removal systems must be taken into consideration. Examples of this are heat removal fans or hot water heater flues.

EQUIPMENT LOCATION

1. Position Autobroil™ to properly align with exhaust hood. Check name plate for clearance requirements.
2. The hood/ventilator for the catering equipment should be located in accordance with the National Fire Protection Association Standard #96, "Removal of Smoke and Grease-Laden Vapors from Commercial Cooking Equipment" and any local applicable requirements.
3. For proper installation, the minimum clearance from combustible construction is 6" (152mm) from sides and 6" (152mm) from back.
4. Adequate clearance should be maintained to allow easy access to loading and unloading areas of the machine.
5. For servicing, unit must be moved 2' (610mm) clear from all construction.

ELECTRICAL INFORMATION

1. The Electrical Schematic is inside the electrical cabinet, and a copy is also included at the back of this manual. Make certain the supply voltage and number of supply conductors agrees with the Electrical Schematic. The load-carrying conductors should be sized according to the loads shown on the Electrical Schematic per local codes and the National Electrical Code, ANSI/NFPA 70 -Latest Edition. If the broiler is supplied with a cord, it will be type 4/4 or 6/4 SO 90 DEG C or higher, L1, L2, L3 and ground (See electrical schematic for proper cord size). The cord will be approximately 9 feet long.
2. On a new electrical service - **MAKE CERTAIN THAT VOLTAGE IS WITHIN 10% OF THE UNIT'S RATED VOLTAGE.** Appliance should be protected by a properly-sized circuit breaker furnished from the main building circuit panel.
3. There is an Electrical Schematic located in the back of this Owner's Manual and also inside the electrical cabinet of the machine.

OWNER'S MANUAL



2424, 121224 AUTOBROIL™

III. OPERATING INSTRUCTIONS

PRE-OPERATION CHECK (START-UP)

Before operating your Autobroil™, make a quick check of critical items as follows:

1. Check that no "binding" and resultant conveyor overloading is present. With the electrical connections complete and with the electrical cabinet door secured shut, turn the broiler **"ON"** and run the conveyors. Adjust the speed control for mid-point speed. The conveyor should move forward in smooth unaltered motion. Shut down immediately if there is any evidence of "binding" or other mechanical blockage.
2. Proper conveyor operation is when the amperage draw in the white or black motor lead from the circuit board (Figure 4) to the motor cord measures .15 DC amps or less. To check amperage the cabinet door will need to be open. **THIS PROCEDURE SHOULD ONLY BE PERFORMED BY A QUALIFIED ELECTRICIAN.**
3. The Autobroil™ was tested at the factory before shipping so excessive amperage will indicate conveyor binding caused by shipping damage. Remove the roller chain (Figure 4) driving the conveyor in question and move the conveyor by hand. Loosen the sprockets (Figure 4) that drive the various axles and reposition them by 1/32" (1mm) until the conveyor tightness is eliminated. Twenty-five inch pounds of torque is required to drive a properly set up conveyor.
4. After the conveyor checkout is complete, turn on the heat switch. All heater elements should glow red. After the unit is up to temperature, these two elements will cycle. For trouble shooting problems, see Section V. **CAUTION: NEVER RUN HEAT WITHOUT CONVEYOR ON AS THIS CAN WARP THE CHAIN.**
5. Before first use, and after any special cleaning, it is necessary to "season" the **BROILER** chain. This is done by bringing the broiler chain to operating temperature and applying liquid shortening from a saturated cloth over the full width of the broiler chain while the chain makes five or six complete revolutions.
6. Check to see that the three heat reflectors (Figure 3) are in place.

BROILER ADJUSTMENT

The Autobroil™ requires 30 minutes to reach stable temperature. After this time lapse, the conveyor speed can be set to properly cook the product. The control will display "READY" when the broiler reaches cooking temperature.

TOASTER OPERATING INSTRUCTIONS

1. The temperature control is located behind the right side lift-off cover. The control is factory-preset for 425°F (218°C).
2. Adjust the bun platen height over the conveyor so the platen touches the bun as it is moved under the platen. To lower platen, turn the knob counter clockwise. To raise platen, turn the knob clockwise. This produces a caramelized surface. If the platen is adjusted too low, the bun will be crushed.

OWNER'S MANUAL



2424, 121224 AUTOBROIL™

TOASTER SHUT-OFF INSTRUCTIONS

1. The toaster section will continue to operate when the main heating (cooking) section of the broiler is on.

DURING A PROLONGED POWER FAILURE, NO ATTEMPT SHOULD BE MADE TO OPERATE THE CATERING EQUIPMENT.

TOASTER CONVEYOR SPEED

1. The toaster conveyor is the lower conveyor on the broiler. This conveyor is linked to the main cooking chamber broiler and does not have a separate speed control for the toasting section. For broilers without computer controls, the toasting section is controlled by adjusting the toasting section temperature, using the control located behind the right side lift-off cover.

OWNER'S MANUAL



2424, 121224 AUTOBROIL™

OPERATION OF 6-BUTTON CONTROLLER

1. USER INTERFACE

The following is the user interface layout. This control is located on the front of the broiler on the right side.



The Control Panel illustration above shows a typical control interface layout. Also See Figure 5 for Description of the Buttons. A Control Panel Quick Guide is located at the end of this manual.

OWNER'S MANUAL



2424, 121224 AUTOBROIL™

TIME AND DATE SETUP (USED ONLY ON BROILERS WITH FOOD PROBE OPTION)

When the controller is in Off mode, the system Time and Date can be adjusted by pressing the Off Key for 10 seconds. The time is displayed on the 1st line, and the HH is blinking. Using the Up and Down Keys, the hours are changed. Pressing the View Key moves the "focus" to the MM. Use the Up/Down Keys to adjust. By pressing View Key again, HH:MM are replaced by DD/MM (or MM/DD, depending on setting of temperature units) (1st line) and YY (2nd line). Use the View Key to travel from one setting to another, and use the Up/Down Keys to modify. The View Key will return to HH:MM. Pressing the Off Key again stores the new Time and Date, and returns to Off mode.

ON/OFF KEYS

A normal press of this key turns on the controller. This causes the unit to start heating the elements and running the motors at the slowest recipe speed found (overcooked food is safer than undercooked food). This recipe is automatically selected (its corresponding LED lights up) and the temperature set point is the one defined by this same recipe. At any time in On mode, the user can change the selected recipe. When initially turned On, the unit will scroll **PREHEAT** on the 1st line until the broiler comes up to temperature. After this time, unit will display either **READY**, **LOW**, OR **HIGH**, depending on the current temperature readings.

A 3-second long press of the On/Off key turns off the unit. When the unit is turned Off, the Heater Kill output is deactivated to disable power to heating elements. The 1st line will then blink **HOT** for the Cool Down period (heating elements are off, but the conveyor motor is still running at the fastest speed allowed by the unit). At that point, the unit will then simply display **OFF**, and all outputs will be disabled.

RECIPE KEYS

Recipes are defined by a time and a temperature. The time basically sets the conveyor speed. The top three (3) recipe buttons are for the left conveyor belt and the bottom three (3) buttons are for the right conveyor belt.

When the unit is **READY**, a simple press of the recipe key will activate the selected recipe speed and temperature (**LOW** and **HIGH** conditions may or may not be triggered).

When a specific recipe must be changed, keep its button pressed for 3 seconds, until the 1st parameter name **SET COOK TIME** scrolls on the 1st line. The recipe as well as the Up/Down LED's will also blink indicating that they can be used. Pressing either Up or Down the 1st time simply makes the display switch to the parameter's value (preceded by an arrow, as in **▶ 4.25**, to indicate a changeable value). Subsequent presses will then modify the parameter. If Up or Down is not pressed in 5 seconds, the display resumes scrolling the parameter name.

Each recipe has 3 programmable parameters. To switch from one to the next, press the recipe key. After the last parameter is programmed, the unit resumes normal operation.

- **SET COOK TIME**,
- **SET TOP TEMPERATURE**,
- **SET BOTTOM TEMPERATURE**.

By default, all recipes are set as follows:

Cook time: **5.00**

OWNER'S MANUAL



2424, 121224 AUTOBROIL™

Top temperature: 1325 °F
Bottom temperature: 1250 °F

VIEW KEY

The View key allows a user to view actual or programmed system parameters. Changes cannot be made just by using this key.

In normal operation (On mode), pressing the View key will start scrolling the message BOTTOM TEMPERATURE; also, the View and Up keys blink, indicating they can be used. If the broiler has two conveyors, the down key also blinks. The 2nd line shows the current conveyor speed of the illuminated recipe key. Pressing the Up key causes the 1st line to toggle between the message and the actual temperature value. The down key will cycle to the recipe for the second conveyor. A final press of the View key resumes normal operation.

When simply pressing the view key (not holding for 3 seconds), the 2nd line always shows the current conveyor speed. If the unit is Off, or Hot, the conveyor speed is not shown.

A 3-second long press of the View key allows users to see the current recipe programs without actually being able to change them. After this delay all 6 recipe LED's blink, allowing the user to select the wanted recipe. Once a recipe is selected, the procedure is the same for all recipes. The 1st parameter shows COOK TIME. By pressing the Up key, the user can view the value that is currently programmed (but cannot change it). In 5 seconds the unit returns to the parameter name. Pressing the Recipe key a 2nd time will bring up BOTTOM TEMPERATURE. Again, using the Up key, the value can be seen. In 5 seconds, the unit returns to the parameter name. Pressing the recipe key one last time returns the unit to normal operation.

CONVEYOR ONLY KEY

The Conveyor Only key is only accessible from the Off state. This key allows the conveyor to be used without any heating. Press the Conveyor Only Key, then press the View Key. Press the Up arrow to start the left conveyor moving. Do not run the conveyor faster than 230 on the display. Press the Conveyor Only key to return to Off state. To start the other conveyor moving, press the View button 2 times, then press the Up Arrow to the desired speed. This does not change the programmed speed.

The parameter name **SPEED** is displayed on the 1st line. The current speed is displayed on the 2nd line (expressed as a time). The flashing triangle indicates the speed can be changed using the Up and Down keys. Exit this mode by pressing Conveyor Only a 2nd time; however, the speed selection is lost (i.e. the 1st speed used in **READY** mode is always the slowest recipe speed).

The display shows the theoretical motor shaft speed (divided by 100) on the top display, and the real tachometer input (divided by 100) on the 2nd line. The theoretical value is simply derived from the requested speed (in terms of time) and the programmed K value. The real value is exactly that, the value coming in from the external tachometer. In an ideal world, the top and bottom lines should read very close to the same value.

The next screen of data in the Conveyor Only mode is the real RPM coming in from the tachometer input. By pressing the View key a 2nd time, this is displayed on the 1st line (which has enough characters to display the information, as in the previous screen). A third and final press of the View key returns to the standard Conveyor Only screen with **SPEED** on the 1st line.

OWNER'S MANUAL



2424, 121224 AUTOBROIL™

RECORD/RECOVERY KEY

A recovery time is the time required for the temperature to go from 200°F to 800°F. A log exists for each heater (top and bottom). This is useful for service and HACCP purposes.

Do not press the Recovery Key while in the conveyor only mode. This key is available anytime the broiler is in normal operation. When pressed, the controller will list a log of the last 3 recovery times.

When the Recovery Key is pressed, the controller will successively display **TOP 1**, **TOP 2**, **TOP 3**, **BOT 1**, **BOT 2**, AND **BOT 3** recovery times, "1" being the most recent ramp logged. To actually see the logged time, press the Up key. After the last set is seen (**BOT 3**), the unit resumes normal operation.

FOOD PROBE KEY – THE FOOD PROBE IS OPTIONAL AND MAY NOT BE INSTALLED ON ALL BROILERS

This key is useable only when the unit is On (and the Food probe is enabled in the Low-level programming). It is accessible in 2 modes: automatic or manual. In manual mode, it is up to the user to press the Food Probe key to initiate a log, whereas, the automatic mode will remind the user (up to 6 times a day) to take a sample. Even in automatic mode, the user still has the capability to log extra samples manually as he/she wishes.

To do a manual log, the user must first make sure the temperature probe is correctly connected, and then press the Food Probe Key.

Step #1

This step prepares the controller for logging.

Display: **SELECT RECIPE TO LOG** is scrolled and recipe LED blink.

Sound: None.

User Action: Select the Recipe corresponding to the sample that will be probed.

Step #2

This step starts the logging as such, and gives the user time to set up for the sampling.

Display: Shows **INSERT PROBE**. Actual temperature can be seen when Up key is pressed. The Up key and Record LED blink.

Sound: None.

User Action: Insert the Food Probe into the sample according to local sanitary codes and normal restaurant procedures.

Step #3

In this step (basically a continuation of Step #2), the temperature continues to be displayed for the user. Nothing is being logged yet. The user must wait until a certain temperature is reached (that depends on what is being sampled (chicken, beef, etc.), as well as specific restaurant procedures).

Display: The 1st line displays the temperature currently measured by the Food Probe. The Record key LED also blinks.

Sound: No particular sound.

User Action: Keep Food Probe inserted. When temperature reaches a specific point (known to

OWNER'S MANUAL



2424, 121224 AUTOBROIL™

the user), the user presses the Record button.

Step #4

When the Record button was pressed, 2 things happened: the "Start Temperature" was stored, and the equalization timer was started. The controller now waits for the timer countdown to finish.

Display: The 1st line continues to display the temperature currently measured by the Food Probe. However, there are no keys that function at this point.

Sound: A beep every 1 second until 5 seconds before end of timer. During last 5 seconds, beeps accelerate to 2 beeps per second.

User Action: Keep Food Probe inserted.

Step #5

In this last step, the actual log is written to memory. The temperature now displayed is logged as the "End temperature."

Display: Last temperature read when timer reached zero is displayed until Food Probe Key is pressed again. This exits Food Probe.

Sound: None.

User Action: Remove probe, and press any key to resume normal operation.

Data Logged

The following is logged each time a sample is taken (in Step #5):

Date/time stamp (MM/DD/YY if English (degree F), DD/MM/YY if Metric (degree C) as well as HH:MM)

Recipe number (that was selected by user)

Top element temperature

Bottom element temperature

Food "Start temperature" (when user pressed Record)

Food "End temperature" (at the end of the equalization time)

NOTE: At the end of Step #5, the user can record another sample of same recipe by pressing Record again instead of Food Probe, which clears display of previous samples. Display then shows probe's current temperature and Steps 3, 4, and 5 are repeated.

UP AND DOWN KEYS

These keys are used to adjust the various system parameters when required. Time is incremented/decremented at 5-second intervals, and temperature at 5°F (2°C) intervals. These keys have a typematic feature associated with them. Keeping them pressed for more than 2 seconds causes the rate of change to accelerate to 25°F/10°C (temperature), or 20 seconds (time) every 500 msec.

2. DISPLAY GENERAL

In general, all messages are scrolled on the 1st line (about 2 characters per second), and times are displayed on the 2nd.

Some keys have a LED, which is used to indicate various situations.

- On/Off LED: full on when broiler is On, otherwise Off.

OWNER'S MANUAL



2424, 121224 AUTOBROIL™

- Up/Down LED's: blink when Up/Down keys are expected.
- Recipe LED's: on when a recipe is active, blinking when programming or viewing recipes.
- Conveyor Only: blinking when feature is in use.
- Recovery: full on when feature is in use.
- Food Probe: off.
- View: full on when feature is in use.
- Conveyor: this is a group of 3 LED's that simulate a rotating motion (about 2 changes per second). This is active whenever the controller is receiving pulses from all installed tachometers.
- Top and Bottom Heater LED's: full on when the corresponding heaters are on, otherwise off.

Also, whenever the arrow symbol (▷) is displayed with the data, this means that this is a parameter being changed/adjusted.

TIME DISPLAY

All conveyor speeds are displayed on the 2nd line, and are limited to 9.59. All other times are displayed as MM.SS, or HH:MM (in Low-level programming, this information is on the top line, which has more characters available). For example, 9.59 is 9 minutes and 59 seconds, and 1:10 is 1 hour and 10 minutes.

3. SYSTEM STATES

There are several states of operation as follows:

POWER-UP STATE

When a power-up occurs, there is a lamp test, where all LED's come on for 5 seconds (this includes all LED's in the two displays). Following the lamp test, the software number and revision are displayed. These are useful for troubleshooting purposes when several versions exist in the field. The first line shows the software number and the second line shows the revision in the format 1.09. Following this, the unit falls automatically into Off mode.

OFF STATE

In this state, the heaters are disabled. Nothing is displayed, except for OFF on the 1st line.

The conveyor motor(s) may be used (and the speed displayed on the 2nd line) if the Conveyor Only function is used. Also the View and Recovery keys may be used in the Off state.

ON STATE

This is the normal cooking state. Before displaying READY, the unit will go through the PREHEAT mode. The pre-heat mode lasts until the pre-heat time expires.

In the On mode, 2 extra conditions may exist: LOW and HIGH. Both depend on the current set point, and the current temperature. If the difference between the set point and the current temperature exceeds the programmable thresholds, then either the LOW or HIGH messages are displayed. This warns the user to wait until the READY condition comes back before putting product onto the conveyor. These conditions are likely to occur when a recipe calls for different temperatures.

OWNER'S MANUAL



2424, 121224 AUTOBROIL™

HOT STATE

This state is active after the unit is turned Off (or if an error occurs that causes the unit to shut-down). This state is basically a cool down step between the On and Off states. The conveyor continues to roll at the *fastest* speed programmed, but the heaters are off. The display continuously shows **HOT** until the Cool Down Time has elapsed, at which point **OFF** appears.

4. DIAGNOSTICS

This section describes the various diagnostics errors that are available.

HEATER TEMPERATURE PROBES

All probes are type-K probes. All temperature readings normally associated with a type-K probe are considered valid by the controller. However, if the probes become disconnected or broken, the controller will sound the buzzer and scroll **HOT - PROBE ERROR** on the 1st line of the display. The defective probe number is displayed on the 2nd line: On the toaster (lower) controller, there are two thermocouples connected:

- **1** is top heater temperature probe
- **2** is bottom heater temperature probe

On the broiler (upper) controller, there is only one thermocouple connected. Pressing any key shuts the buzzer off, but will not remove the error message. The only way to remove the error message is to resolve the probe and/or connection problem.

When these heater probe errors occur, there are 2 possible ways to react, depending on the Probe Error parameter:

- If Probe Error Action is set to 0 (default), the unit goes into shutdown via the **HOT** state. After the Cool Down delay, the error message becomes **OFF - PROBE ERROR** instead of **HOT - PROBE ERROR**.
- If Probe Error Action is set to 1, then the unit continues operation, at full temperature. The operator will most likely have to adjust the recipe times, but at least the unit can still operate.

EXTERNAL DC ERROR

The DC I/O connector has a +5VDC supply. This supply is internally protected against over-currents. Should this occur, the unit will internally disconnect the supply and report **HOT -**

EXTERNAL DC ERROR. The unit goes into shutdown (through **HOT** mode) and the only way to reset this is to resolve the problem (most likely a short). Since the buzzer is powered through the same +5VDC supply as the DC I/O connectors, the buzzer does not sound when this error occurs. After the Cool Down delay, the error message becomes **OFF - EXTERNAL DC ERROR** instead of **HOT - EXTERNAL DC ERROR**.

5. EMERGENCY STOP SWITCH

An emergency stop switch is available on the front of the broiler as shown in Figure 1A. This toggle switch is for immediately stopping the conveyors in case of a conveyor jam or other problem requiring the broiler to shut down.

Do not use this switch for normal shut down at the end of the day. Use it if the conveyor jams or you need to stop the broiler quickly. This switch stops the conveyors and turns off the heating elements and turns off power to the control panels. When you turn the "Emergency Shut Off Switch" back on, the control panels will cycle through an initialization, then display "Off." From here you can start as normal.

OWNER'S MANUAL



2424, 121224 AUTOBROIL™

IV. SCHEDULED MAINTENANCE

DAILY CLEANING PROCEDURES

CAUTION: Do not touch the broiler section immediately after appliance shut-down. The temperature inside enclosures is in excess of 500°F (260°C), which eliminates the need to clean any parts inside the enclosures for sanitary purposes. Any grease that may build up on the exterior of the enclosures should be cleaned off with a damp cloth and a minimum amount of detergent. **Disconnect the power supply to the appliance before cleaning or servicing.**

CAUTION: **Under no circumstances should oven cleaner be used on this appliance. IT WILL EAT HOLES IN THE LOWER PLATEN (HOLDING AREA). CAUSTIC FUMES CAUSE ELECTRICAL COMPONENT DAMAGE, AND WILL CAUSE MANY OTHER PROBLEMS IF USED TO CLEAN THIS BROILER.**

CAUTION: **KEEP THE APPLIANCE AREA FREE AND CLEAR FROM COMBUSTIBLES.**

1. Allow broiler burners and chain to operate for 30 minutes after cooking last patty to burn off excess grease on broiler components. Then turn the unit off and allow to cool. (This applies every time a meat chain is turned off -- regardless of what time of day meat chain is shut down -- and regardless of how few patties were broiled in the last 30 minutes, last hour, etc.) This will clean some parts of the cooking chamber. Failure to perform this procedure daily will result in poor cooking times.
2. Remove all exterior panels except those which are attached with screws. Be careful not to touch any hot internal broiler components.

*	Grease Drain Channel	Figure 3
*	Grease Pans	Figure 2
*	Crumb Tray (Toaster Section)	Figure 2
	Front and Rear Tunnel Guard	Figure 2
	Heat Shield Assembly	Figure 2
	Tunnel Filler	Figure 2
*	Broiler Arm Cover and Heat Guard	Figure 2
*	Broiler Grease Tray	Figure 2
	Tube Bundle Asby (2)	Figure 2
	Meat Stripper	Figure 3
*	Grease Catch Pan and Insert	Figure 2
	Toaster Bun Tray	Figure 2
*	Toaster Arm Covers	Figure 2
* NOTE: these items may be removed during the 30 minute period.		

OWNER'S MANUAL



2424, 121224 AUTOBROIL™

3. With the conveyor running and heat OFF, wire brush the broiler conveyor and, as it cools, wipe with damp cloth.
4. Scrape deposits from the axles with the axle scraping tool, furnished with each machine as shown in Figure 6. * **THIS IS IMPORTANT TO PREVENT GREASE FIRES AT THE REAR OF THE BROILER.**
5. Remove grease and meat residue from any part of remaining broiler structure where visible. Use a damp cloth with detergent and a putty knife for best results. * **DO NOT SCRAPE THE LOWER PLATEN (HOLDING AREA).**
6. The tube bundles (2) (Figure 2) should be removed and wire brushed. Further cleaning is not necessary; however, make sure carbon deposits are scraped from between the tubes with a tool such as a screwdriver.
7. Additional cleaning should exhibit good housekeeping and entail a general wiping of all exterior surfaces. **DO NOT GET WATER ON THE ELECTRICAL CABINET OR THE HEATING ELEMENTS. NEVER HOSE THE MACHINE.**
8. After cleaning all removable parts as noted, allow to dry and reassemble.

MONTHLY CLEANING PROCEDURES

1. Remove the broiler conveyor chain from the machine and steam clean or soak in detergent solution. The conveyor is removed by taking the conveyor apart at the cutlinks. When the conveyor is removed, check all heating elements and replace elements showing extreme corrosion. Check bearings for excessive wear and order replacements where needed. (See Figure 5 for cutlink illustration.) Make certain conveyors are reinstalled going in the correct direction. **PLACING CHAIN ON BACKWARDS WILL CAUSE SEVERE BINDING PROBLEMS.**
2. Remove spark guard and wipe out. (Figure 2)

QUARTERLY CLEANING PROCEDURES & PREVENTIVE MAINTENANCE

1. If required, remove conveyor and soak in hot soapy water overnight. The chain is removed by lifting axle up to produce slack and separating as described in Figure 5. When replacing chain, make certain the conveyor is installed properly. **PLACING CHAIN ON BACKWARD WILL CAUSE SEVERE BINDING PROBLEMS. CLOSE** open links to match other links. (Figure 5)
2. If required, spread conveyor links open with screwdriver or chain pliers (part#500033). Lift front axle up to make slack in the conveyor belt, unhook conveyor chain and remove to gain access to lower cooking chamber for cleaning side walls. Make reference to the orientation of the conveyor links and the conveyor direction for reassembly. (Figure 5)
3. Lubricate the roller (drive) chain with a few drops of any grade motor or machine oil.
4. Remove and inspect all motor brushes and replace if less than 1/4" (6mm) is left.
5. **CAUTION: DISCONNECT POWER BEFORE OPENING PANEL.** Retighten the screw lugs on the main power wires at the main terminal block or contactor inside the control box. Check that other electrical connections are still tight. Check that fuse block wire connection screws are tight.

OWNER'S MANUAL



2424, 121224 AUTOBROIL™

INVENTORY THE SPARE PARTS KIT (IF APPLICABLE) AND ORDER MISSING PARTS AS NEEDED. KEEP A COMPLETE SET OF PARTS ON HAND AT ALL TIMES.

TROUBLE SHOOTING

This section contains a list of possible problems with your Autobroil. By locating the problem in this section, you may be able to make a quick repair. **ALL ELECTRICAL TROUBLE SHOOTING INVOLVING ACCESS INTO THE MOTORS OR ELECTRICAL ENCLOSURES MUST BE PERFORMED BY A QUALIFIED ELECTRICIAN.**

* **INSTRUCTIONS MARKED WITH ASTERISKS SHOULD BE PERFORMED BY AUTHORIZED SERVICE PERSONNEL.**

1. MACHINE HAS POWER BUT ELEMENTS ARE OUT.

POSSIBLE CAUSE

- A) Check to make sure broiler on-off switch is in "**ON**" position and that the correct voltage is coming out of switch (see Electrical Schematic).
- B) Check that heat switch is in **ON** position.
- C) Check that power is passing to and through the mercury relays.
- D) Check wiring to individual elements.
- E) Check fuses to each element.
- F) Check elements.

2. CONVEYOR CHAIN WILL NOT MOVE.

POSSIBLE CAUSE

- A) Check for object caught in conveyor, causing a jam. **SOLUTION:** Remove object.
- * B) Check 1.5 amp fuse on side of the control cabinet. **SOLUTION:** Replace if blown and turn broiler off, and turn broiler on.
- * C) Check 10 amp fuse. **SOLUTION:** Replace if blown.
- D) Check to see if motor shaft is moving. **SOLUTION:** Sprocket needs to be tightened.
- * E) Check switch to make sure power is flowing through it. **SOLUTION:** Replace switch.
- * F) Connect motor control leads to an operating motor speed control board. **SOLUTION:** If motor runs, replace motor control board. If motor still does not run, replace motor.

OWNER'S MANUAL



2424, 121224 AUTOBROIL™

3. CONVEYOR RUNS BUT SPEED IS CONSTANT

POSSIBLE CAUSE

- * A) There are four parts to the motor system. They are the motor, the circuit board, the rotary speed control and the fuse mounted on the side of the control cabinet. The most likely problem would be a blown fuse. **SOLUTION:** Using spare parts, replace one part at a time until the trouble spot is identified.

4. REPEATED MECHANICAL BINDING.

POSSIBLE CAUSE

- A) Check to see that chain is not on backward. **SOLUTION:** See proper chain installation on Figure 5.
- B) Inspect chain closely for bent or warped links that may be snagging and causing a binding condition. Also check that the chain links are not climbing out of the sprockets as the conveyor rotates. **SOLUTION:** Straighten or replace bad links. Season new links with cloth saturated with shortening before broiler reaches full operating temperature.
- C) Make sure the axle assembly is clean and free of grease and food residue to allow smooth movement of the conveyor. **SOLUTION:** Clean axle. See Figure 5.
- D) Check the axle assembly to make certain all set collars, bearings, etc. are properly positioned and secure.
- E) Disassemble conveyor axle assembly and check condition of bushings and bearings for excessive wear. **SOLUTION:** Replace if worn or damaged.
- F) Visually inspect the motor drive chain assembly for smooth rotation of chain. **SOLUTION:** Make certain there are no binding or worn components.
- G) Make sure conveyor is not catching on meat stripper. See Figure 3 **SOLUTION:** Straighten bent stripper.

5. HEAT PLATEN TEMPERATURE CONTROL DOES NOT WORK (LOCATED BEHIND RIGHT SIDE LIFT-OFF PANEL).

POSSIBLE CAUSE

- * If control flashes "EEE" or "999", then inspect thermocouple for continuity. **SOLUTION:** Check to be sure thermocouple leads are securely fastened to temperature controller. If so, then replace thermocouple.

6. MEAT DOES NOT COOK COMPLETELY.

POSSIBLE CAUSE

- A) Check to make sure tube bundle is clean.
- B) Check to make sure the heat shield is installed (Figure 2).

OWNER'S MANUAL



2424, 121224 AUTOBROIL™

- C) Check to make sure all elements are working. If not, check fuses in the control cabinet that protect the elements. Replace fuses and/or heating elements.
- D) Check the speed of the conveyor.
- E) Check refrigeration of meat. Holding temperature of meat may be lower than 0°F (-18°C).
- F) Check for excessive exhaust by momentarily turning exhaust fan off.
- G) Check setting on temperature controller.

7. CANNOT MAINTAIN CONSISTENT TEMPERATURE DURING COOKING.

POSSIBLE CAUSE

- A) Check that tube bundles are being cleaned in accordance with Item 6 in Section IV.
- B) Check store power supply for large voltage variation. A 5% swing in voltage will require more than a 5% change in speed to counteract.
- C) Meat of different temperatures is being used. (Frozen vs. partially thawed.)
- D) Check for excessive exhaust by momentarily turning off exhaust fan.
- E) Check to make sure the heat shield is installed (Figure 2).
- F) Check to make sure all elements are working. If not, check fuses in the control cabinet that protect the elements. Replace fuses and/or heating elements.

8. MEAT OVERCOOKED ON OUTSIDE AND UNDERCOOKED ON INSIDE.

POSSIBLE CAUSE

- A) Check refrigeration of meat. Holding temperature of meat may be lower than 0°F (-18°C).
- B) Check that tube bundles are being cleaned in accordance with Item 6 in Section IV.

9. MEAT NOT SLIDING INTO HAMBURGER CATCH AREA.

POSSIBLE CAUSE

- A) Meat stripper (Figure 3) needs cleaning.
- B) Meat stripper needs adjustment.

10. BUNS WILL NOT GET HOT ENOUGH.

POSSIBLE CAUSE

- A) Check that toaster platens touch bun. **SOLUTION:** Lower platens by turning the knob counterclockwise to correct height to compress buns properly for toasting.

OWNER'S MANUAL



2424, 121224 AUTOBROIL™

- * B) Check toaster platen electrical power. **SOLUTION:** Check temperature control power output.
- C) Check speed to make sure conveyor is not running too fast. **SOLUTION:** Speed should be about 50 to 60 seconds.
- * D) Check element connections to top of toaster platens. **SOLUTION:** Tighten
- * E) Check the sensor to make sure it is inserted into side of platen. **SOLUTION:** Remove control cabinet lid and push sensor into position.

11. BUNS WILL NOT FEED CORRECTLY.

POSSIBLE CAUSE

- A) Check for buildup of black residue on teflon sheet caused by improper cleaning. **SOLUTION:** See cleaning instructions under Daily Cleaning Procedure.
- B) Teflon sheet is worn or damaged. **SOLUTION:** SHEET MUST BE REPLACED.

12. TROUBLE SHOOTING GUIDE FOR 6-RECIPE BUTTON CONTROLS

The following Error Messages are associated with the 6-Recipe Button controls:

ERROR MESSAGE PROBLEM	SOLUTION
-----------------------	----------

TACH ERROR or HOT – TACH ERROR or OFF – TACH ERROR

Note: On the lower display window, the number **1** or **2** or **12** will be shown. **1** indicates a single conveyor problem, or a left conveyor problem on a dual conveyor broiler. **2** indicates a right conveyor problem. When a problem occurs, the first message displayed is **TACH ERROR**, which almost immediately will cause the broiler to shut down and display **HOT – TACH ERROR**. After the cool down period, the broiler will turn off and display **OFF – TACH ERROR**.

Jammed Conveyor	Remove Items Preventing Conveyor From Moving
Failed Fuse	Replace Fuse
Loose Wire or Connector	Check wire connections
Loose Pick-up	Tighten Pick-Up
Failed Pick-up	Replace Pick-Up
Failed Speed Control Circuit Board	Replace Circuit Board
Failed Motor	Replace Motor
Failed Speed Module	Replace Speed Module

HOT – PROBE ERROR or OFF – PROBE ERROR

Note: The number on the second line of the control display indicates the thermocouple number. For electric broilers, **1** indicates the top heater thermocouple, and **2** indicates the bottom heater thermocouple.

OWNER'S MANUAL



2424, 121224 AUTOBROIL™

For gas broilers, which have only one thermocouple, the display will indicate **2**. When a problem occurs, the first message displayed is **HOT - PROBE ERROR**. After the cool down period, the broiler will turn off and display **OFF – PROBE ERROR**.

Loose Thermocouple	Fix wiring connection
Failed Thermocouple	Replace Thermocouple

Depending on the 6-Recipe Button Control factory setting, some electric broilers will default to 100 percent heater output to allow the broiler to continue to operate until the problem is fixed. In this case, the recipe cook time should be temporarily adjusted to achieve the desired cooked product using the 100 percent heat. A **PROBE ERROR** message will be displayed until the problem is fixed.

HOT – EXTERNAL DC ERROR or OFF – EXTERNAL DC ERROR

Check Wiring and Connectors For Short	Repair Wiring
Failed Pick-up	Replace Pick-up
Failed Speed Control Circuit Board	Replace Circuit Board
Failed Speed Module	Replace Module
Failed Gas Module	Replace Module
Failed 6-Recipe Button Control	Replace 6-Recipe Button Control

FOOD PROBE ERROR

Food Probe Not Connected	Plug in Food Probe
Failed Food Probe	Replace Food Probe

CLEAR LOG LOG FULL

Log File almost full	Clear Food Probe Log File
Log File is full	Clear Food Probe Log File

VI. ASSEMBLY & DISASSEMBLY INSTRUCTIONS

1. To Replace the Heating Elements:
 - A. Disconnect power to the broiler.
 - B. Remove the access cover on the element box on the top right side of the broiler.
 - C. Disconnect the wires to the element to be replaced.
 - D. Remove the screws attaching the access cover on the left side of the broiler.
 - E. Pull the element out of the broiler through the slot in the side of the broiler.
 - F. Insert a new element, being careful to position the element rods through the central support.
 - G. Reconnect wiring and install covers.
 - H. Connect power and test operation.

OWNER'S MANUAL



2424, 121224 AUTOBROIL™

2. When replacing the thermocouple which attaches to the hi/low temperature controller, make certain it is inserted through side wall of machine into cooking chamber exactly one inch (1") (25mm).
3. To properly set the clearance between the meat stripper and the conveyor chain, the machine must be HOT. Loosen the bolts holding the brackets to the sides of the unit and adjust their position until the top edge of the stripper is within 1/16" (2mm) of the hot conveyor. See Figure 3.

WARNING: THIS APPLIANCE IS NOT CAPABLE OF BEING SAFELY PLACED INTO OPERATION DURING A POWER FAILURE AND NO ATTEMPT TO OPERATE IT SHOULD BE MADE.

VII. REPLACEMENT PARTS

When ordering parts, make sure to specify the machine model number, type of gas and serial number as shown by the label attached to the right side cover.

PART #	DESCRIPTION	QUANTITY PER UNIT	FIGURE
	2424 AUTOBROIL		
124676	9.5" Conveyor Arm, LH	1	3, 8, 9
132579	9.5" Conveyor Arm, RH	1	3, 8, 9
132579	9.5" Conveyor Arm, RH	1	3
124677	Arm Bearing Bracket	2	3, 8, 9
128147	Arm Cover Asby, 9.5" Arms	1	2, 8
118040	Axle Drive	1	4
118731	Bearing Backup Plate	4	4, 4A
503104	Boxer Cooling Fan, 240V	1	Schematic
118402	Broiler Catch Pan Insert	1	2
134475	Bun Exit Tray Asby	1	2
134475	Bun Exit Tray Asby	1	2
130694	Charcoal Tray Cover	1	3
140158	Circuit Board, 230V Input	2	13, Schematic
141643	Circuit Board, 230V Input	2	Schematic
500211	Contactora	2	Schematic
145704	Control, 6-Button	1	Schematic
116088	Conveyor Idler Shaft	1	3
120030	Conveyor Idler Shaft	1	3, 8, 10
120029	Conveyor Support Pin	1	4
121696	Conveyor Wiper Asby, 24"	1	3
124654	Conveyor, 24" X 73.25"	1	2
135883	Conveyor, 24" X 73.25" LG	1	2
135883	Conveyor, 24" X 73.25" LG	1	2
118529	Crosstube, .5" OD x 24.563"	1	3
116084	Crosstube, .5" Dia. X 24.875"	2	3, 8
501864	Curvette Rocker Switch	1	Schematic
501864	Curvette Rocker Switch	1	Schematic
145727	Element w/ Thermocouple Clip	2	Schematic
503366	Element, 1350W 208V	11	3, Schematic
503366	Element, 1350W 208V	9	3, Schematic
503393	Element, 1441W 220V	11	3, Schematic

OWNER'S MANUAL



2424, 121224 AUTOBROIL™

144139	Fan	2	Schematic
118401	Front Grease Tray	1	2
128364	Front Tunnel Guard	1	2
504052	Fuse, ABC 20	12	14, Schematic
504052	Fuse, ABC 20	12	Schematic
502739	Fuse, AGC - 10	2	Schematic
501139	Fuse, AGC .5	2	Schematic
500061	Fuse, AGC 1.5 AMP	2	14, Schematic
500061	Fuse, AGC 1.5 AMP	2	Schematic
504053	Fuse, MDL – 1/16	2	Schematic
500066	Fuseblock, 2 Pole	1	Schematic
500069	Fuseblock, 2 Pole	7	Schematic
500068	Fuseholder, Panel Mount, 15A 250V	2	Schematic
500068	Fuseholder, Panel Mount, 15A 250V	2	Schematic
124662	Grease Pan Asby	1	2
500732	Ground Lug	1	Schematic
500732	Ground Lug	1	Schematic
501835	Half Size Pan, 4" Deep	1	2
501835	Half Size Pan, 4" Deep	1	2
123879	Hamburger Catch Pan Asby	1	2
123832	Heat Guard, Loading Arm Cover	1	2, 8, 9
145749	Heat Shield	1	2
145749	Heat Shield, Tunnel Top	1	2
124578	Idler Bearing Asby, 1.250" OD x .500 ID	2	3, 8, 10
116090	Idler Bearing Asby, 1.626 Dia., 500 DEG F	2	3
124580	Idler Sprocket Asby	1	4
122551	Idler, 1.688" OD, .755" ID	2	3, 8, 10
501827	Knot with stud	2	4
501827	Knot with stud	2	4
130442	Meat Stripper Asby 121224	1	3
119531	Meat Stripper Hanger, LH	2	3
119530	Meat Stripper Hanger, RH	1	3
121625	Motor Idler Mount	1	4
117234	Motor Mounting Bracket	1	4
118426	Motor Sprocket Guard	1	4
118702	Rear Tunnel Guard Asby	1	2
118007	Side Panel Asby	2	2
118425	Spark Guard	1	2, 7
115813	Spring Tensioning Bracket	2	3, 8, 9
116087	Spring Tensioning Rod	2	3, 8, 9
101357	Teflon Bearing, .750" Shaft	4	4, 4A
118427	Thermocouple Mount-Platen	1	11
121658	Toaster Arm Cover LH	1	2
117248	Toaster Arm, RH	1	3
123844	Toaster Drive Shaft	1	4
118403	Toaster Pan	1	2
102153	Tube Bundle Asby, 12"	2	2
	121224 AUTOBROIL		
136519	Meat Stripper Asby 2424	1	3

OWNER'S MANUAL



2424, 121224 AUTOBROIL™

503287	Motor Brush Type 24Y2FETM-D4	4	N/A
503287	Motor Brush Type 24Y2FETM-D4	4	N/A
500940	Motor, 1/50 HP	1	4, Schematic
500940	Motor, 1/50 HP	2	4, Schematic
131398	Mount, Motor Pick-Up	2	4
145861	Owner's Manual	1	N/A
130694	Reflector Tray Cover	1	3
500035	Roller Chain	4.3 FT	4
500035	Roller Chain	4.3 FT	1
129746	Set Collar Asby, .505" Dia. 500117	2	4
129746	Set Collar Asby, .505" Dia. 500117	2	4
128489	Set Collar Asby, .755" Dia.	1	3, 4, 10
500518	Set Collar, .250" ID	2	3, 8, 9
500518	Set Collar, .250" ID	2	3
500118	Set Collar, 0.750" ID	1	4, 4A
500118	Set Collar, 0.750" ID	1	4
502809	Spring, 2.750"	2	3, 8, 9
502809	Spring, 2.750"	2	3
500040	Sprocket 3510 x 1/2 (Motor)	2	Schematic
143366	Sprocket 3512 x 1/2 for Idler	1	Schematic
134825	Sprocket 5010 x 3/4	4	4A
152705	Sprocket 5010 x 1	2	4A
124643	Sprocket, 3512 x .750" (Toaster)	1	4
502838	Sprocket, 3515 x .750" (Toaster)	1	4
502839	Sprocket, 3524 x .750" (Broiler)	1	4
129210	Sprocket, 3524 x .750" (Broiler)	1	4
108582	Teflon Sheets 12" x 35"	1	4
108582	Teflon Sheets 12" x 35"	2	4
131360	Temperature Controller, DEG F°	1	Schematic
145738	Temperature Controller, Toaster Platen	1	Schematic
500932	Terminal Jumper	1	Schematic
503087	Terminal Strip 12 Pole	1	Schematic
502390	Thermocouple, Type K, 36"	2	Schematic
503416	Thermocouple, Type K, Toaster Platen	1	Schematic
127027	Toaster Arm Cover, RH	1	2
127028	Toaster Arm, LH	1	3
502916	Transformer, 115/230 24V Secondary	1	Schematic
502168	Transformer, 240V Primary, 12V Secondary	2	Schematic
502206	Transformer, 240V Primary, 12V Secondary	2	Schematic
130446	Tunnel Filler	1	2
130446	Tunnel Filler	1	2
128320	Washer, 1.000" OD x 0.765" ID	6	4A

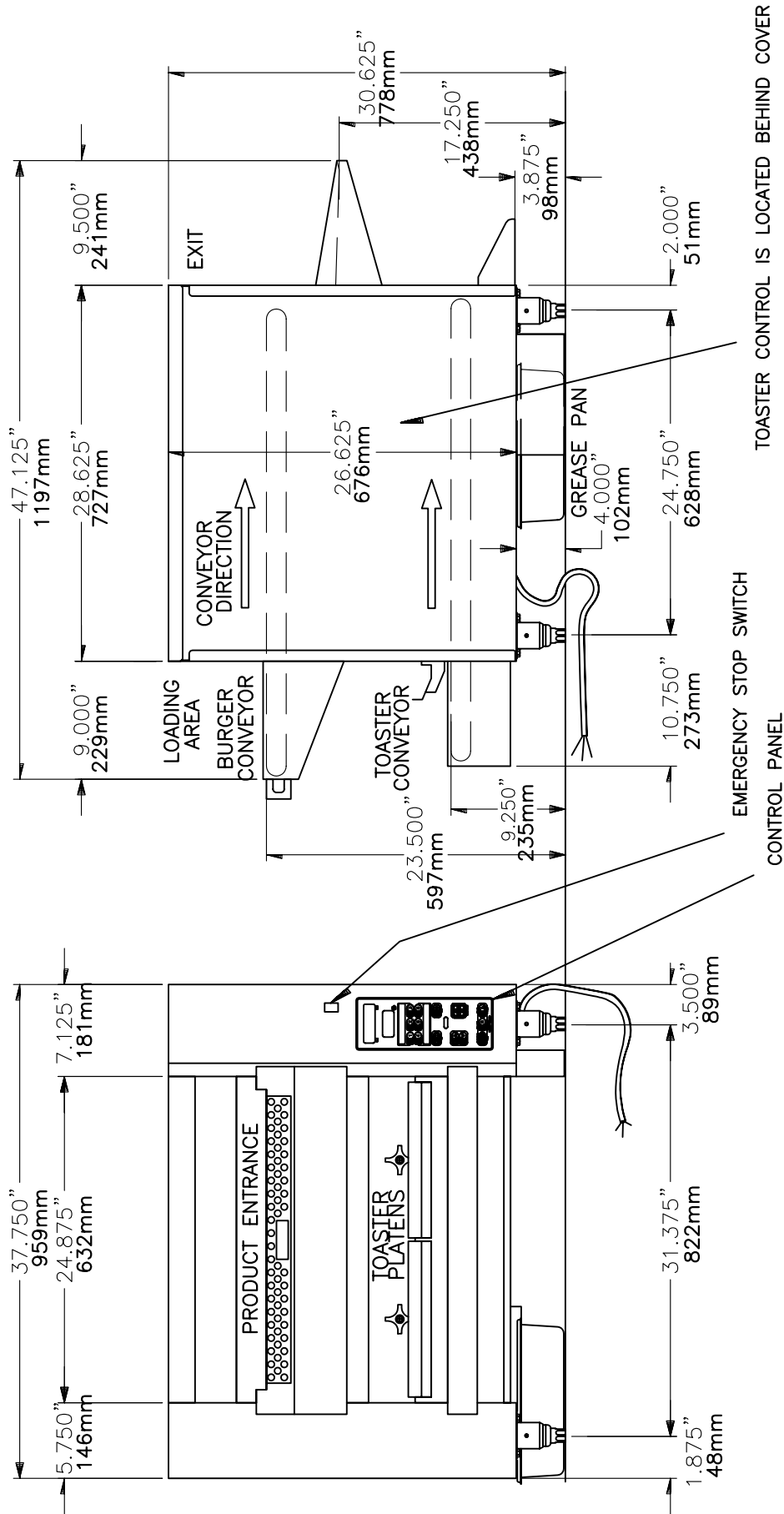

ELECTRICAL INFORMATION:
 208VOLTS, 60Hz, 3PH
 L1 = 60AMPS
 L2 = 60AMPS
 L3 = 50AMPS
 N = N/A

POWER CORD:
 6/4 SEOW 105 DEG C
 3 CONDUCTORS AND GROUND

TOASTER CONTROL IS LOCATED BEHIND COVER

OPTIONAL STAND NOT SHOWN

OVERALL VIEW

FIGURE 1

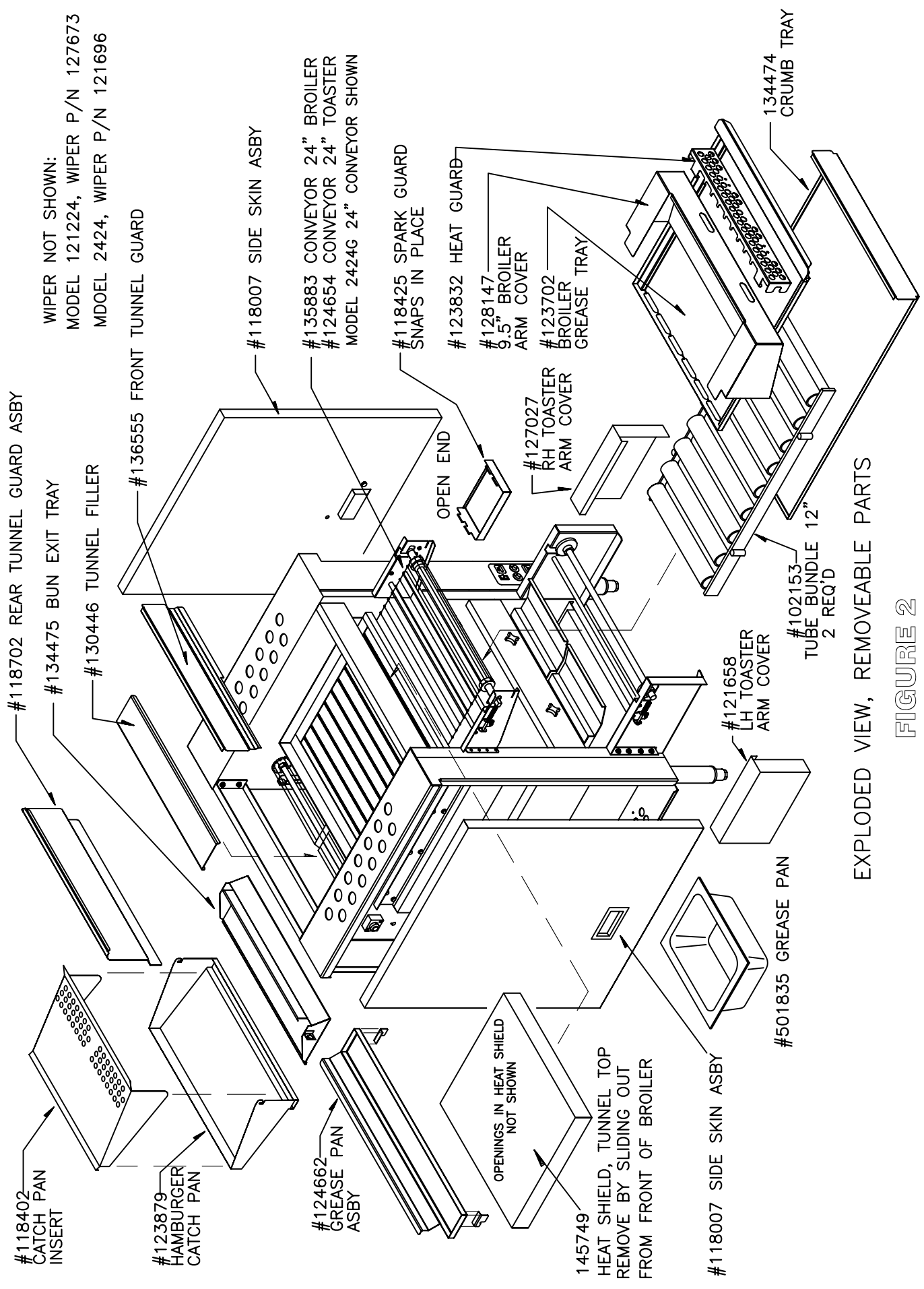

EXPLODED VIEW, REMOVEABLE PARTS

FIGURE 2

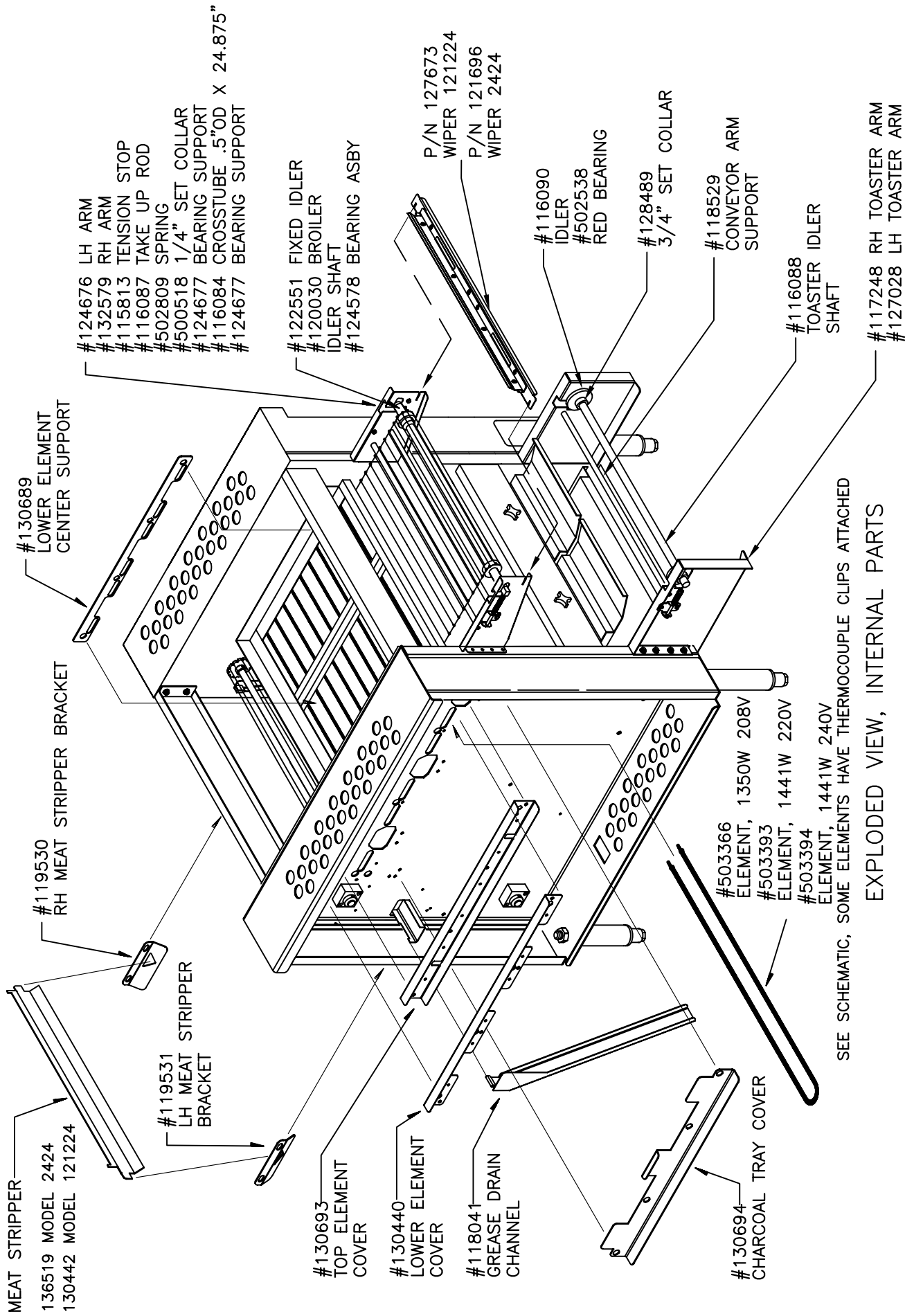

SEE SCHEMATIC, SOME ELEMENTS HAVE THERMOCOUPLE CLIPS ATTACHED

EXPLODED VIEW, INTERNAL PARTS

FIGURE 3

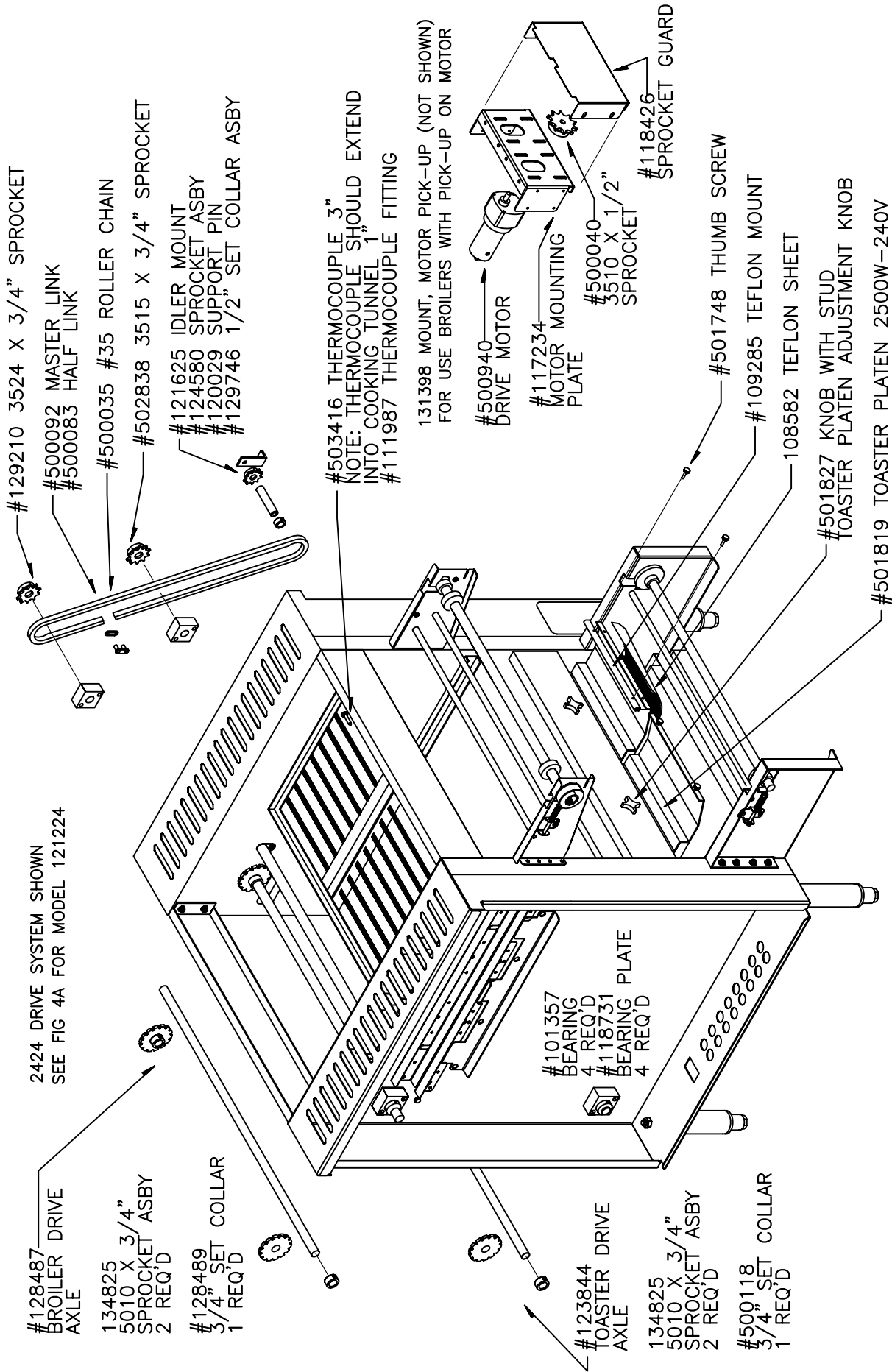

NOTE: ELECTRICAL AND GAS COMPONENTS ARE LOCATED ON THE RIGHT SIDE OF UNIT.

DRIVE SYSTEM AND TOASTER PARTS

FIGURE 4

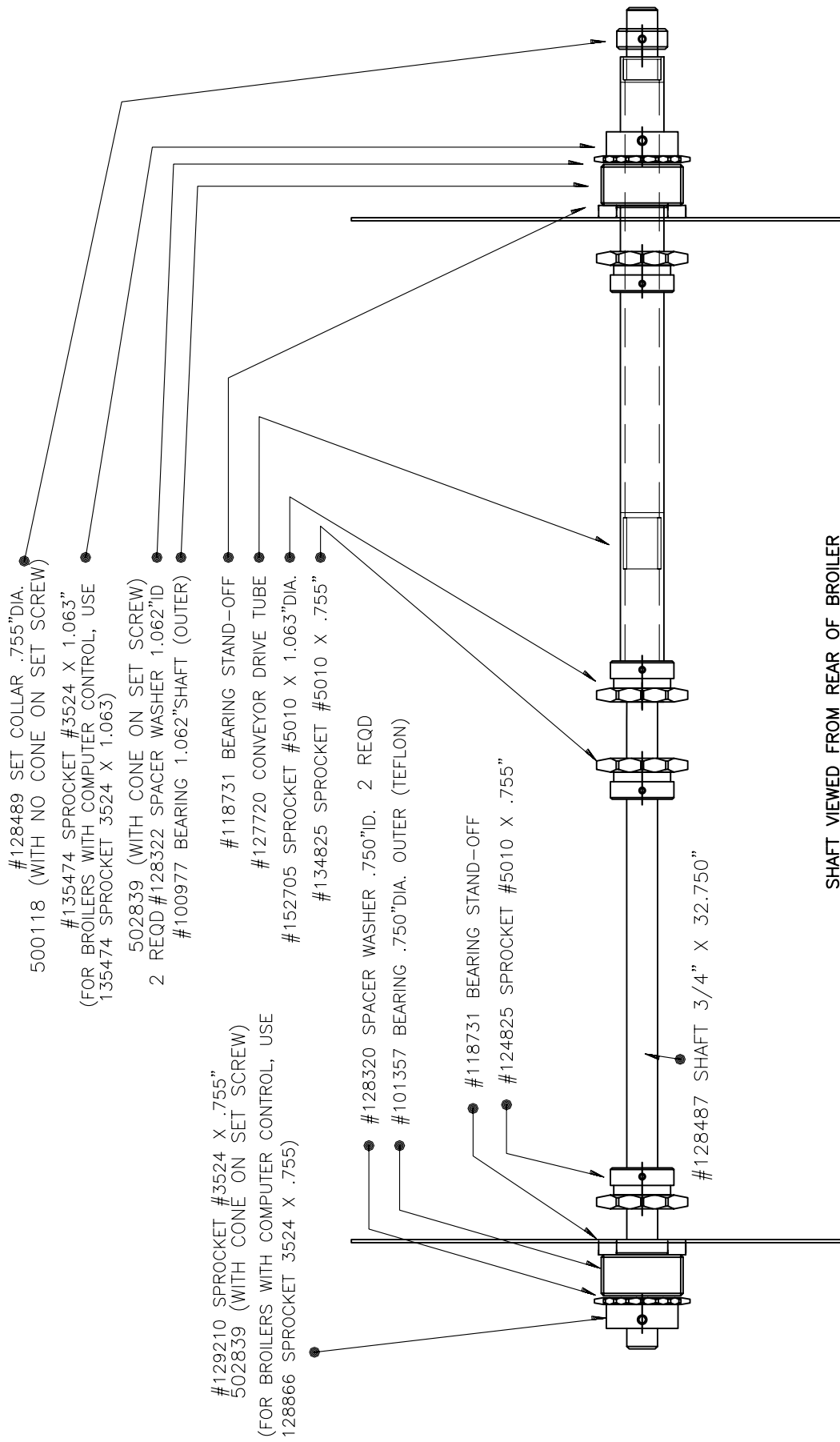

SHAFT VIEWED FROM REAR OF BROILER

DRIVE SYSTEM 121224

FIGURE 4A

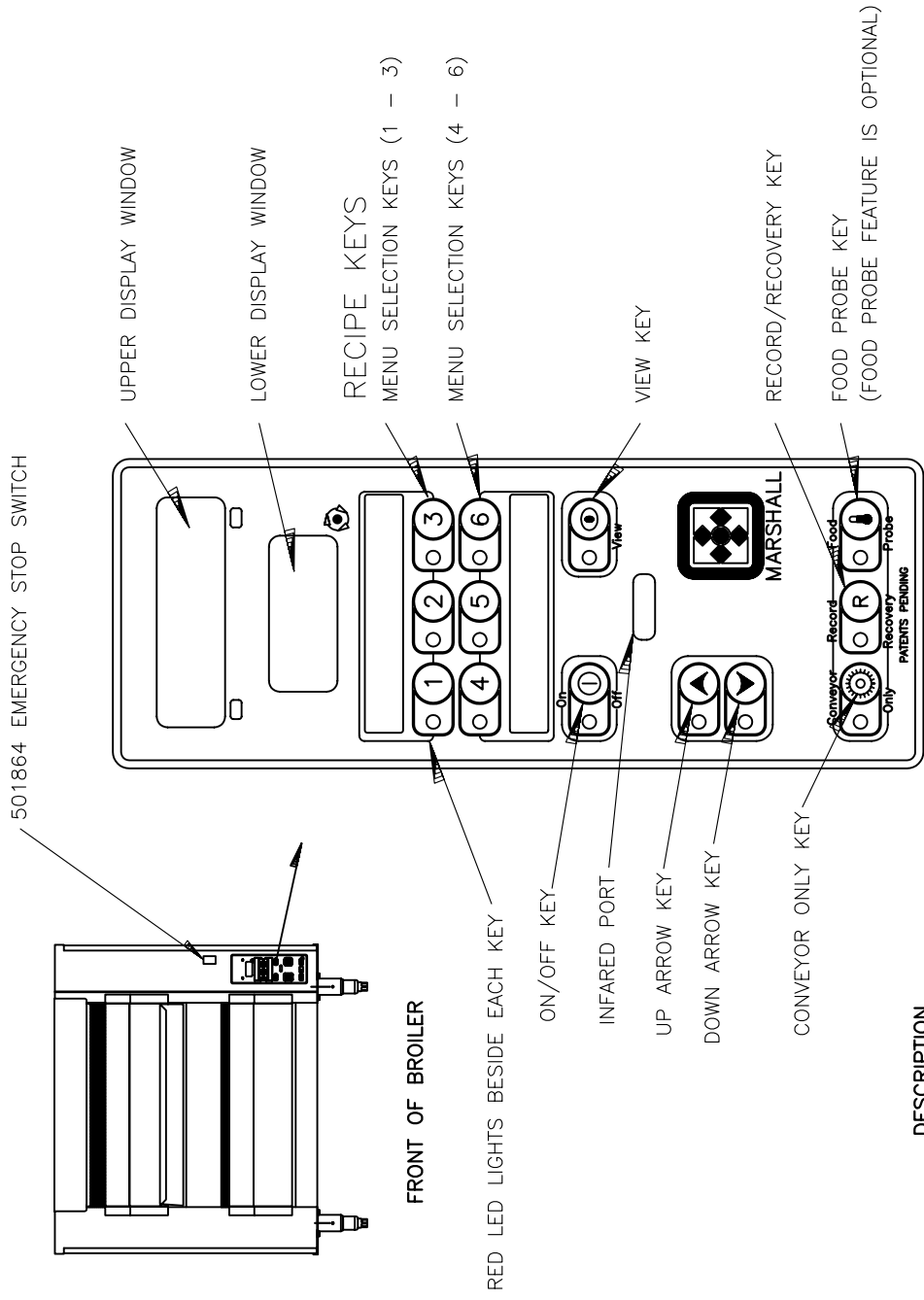

ITEM	P/N	DESCRIPTION
1	503978	OVERLAY CONTROL, SEE SCHEMATIC
2	-	

6-BUTTON CONTROL USER INTERFACER
 FIGURE 5

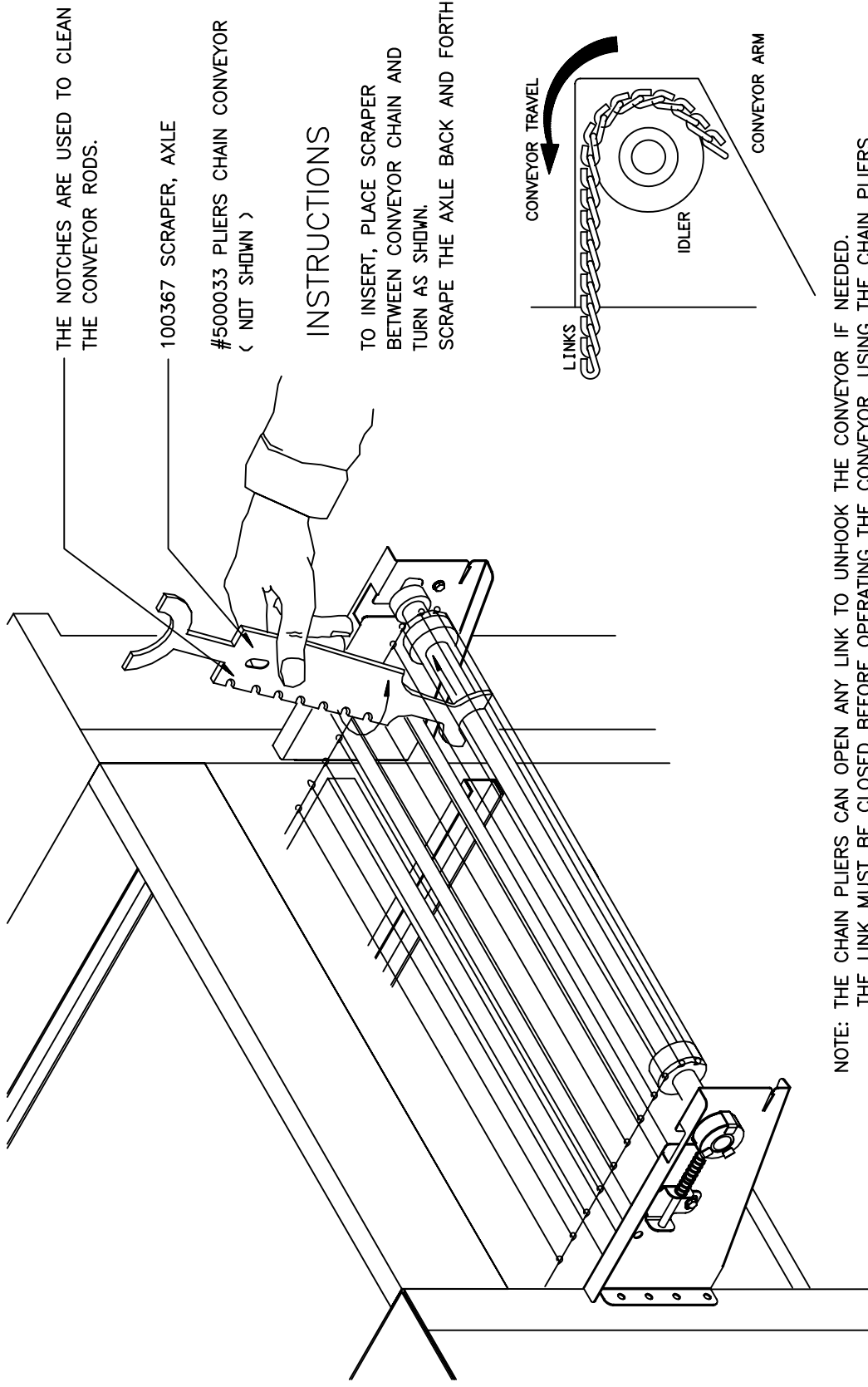

AXLE SCRAPER
FIGURE 6

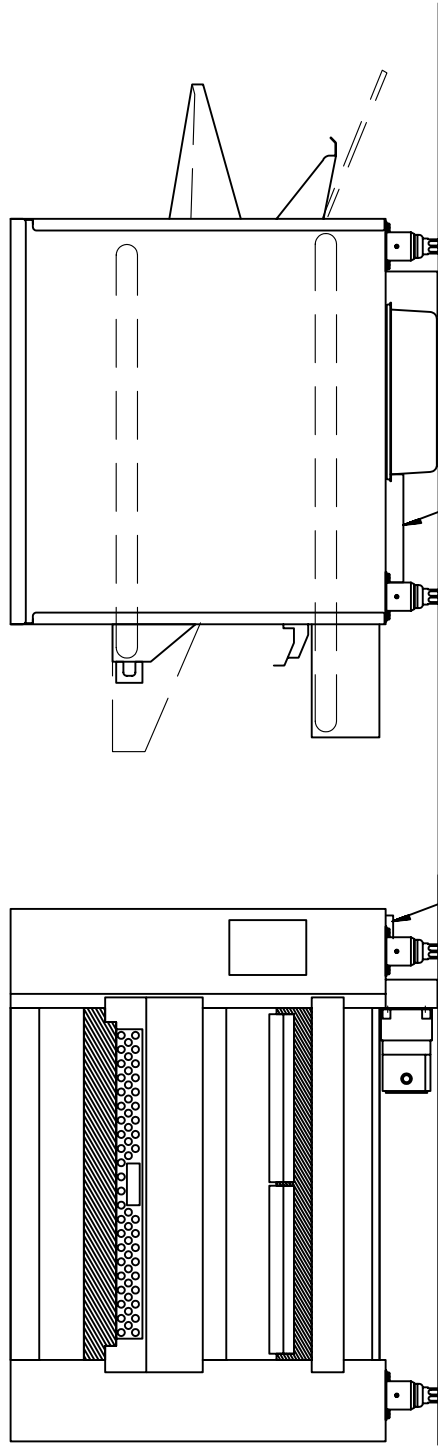

ENLARGED VIEW OF 4 SLOTS ON THE UNDER SIDE OF THE BROILER TO MOUNT THE SPARK GUARD

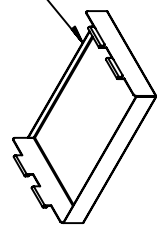
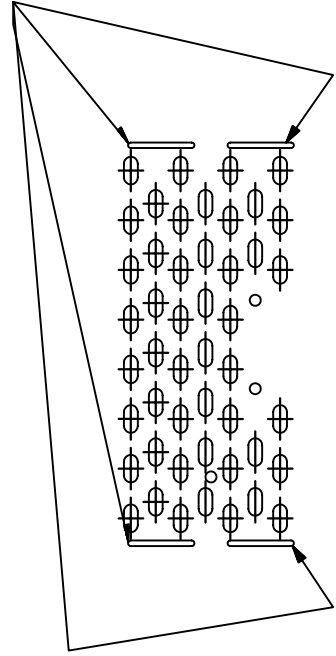

INSTALLATION INSTRUCTIONS

TO INSTALL THE SPARK GUARD INSERT ONE SIDE INTO THE SLOTS ON THE MACHINE THEN PRESS THE OTHER SIDE INTO THE SLOTS UNTIL THE SPARK GUARD CATCHES ON THE TABS.

FIGURE 7

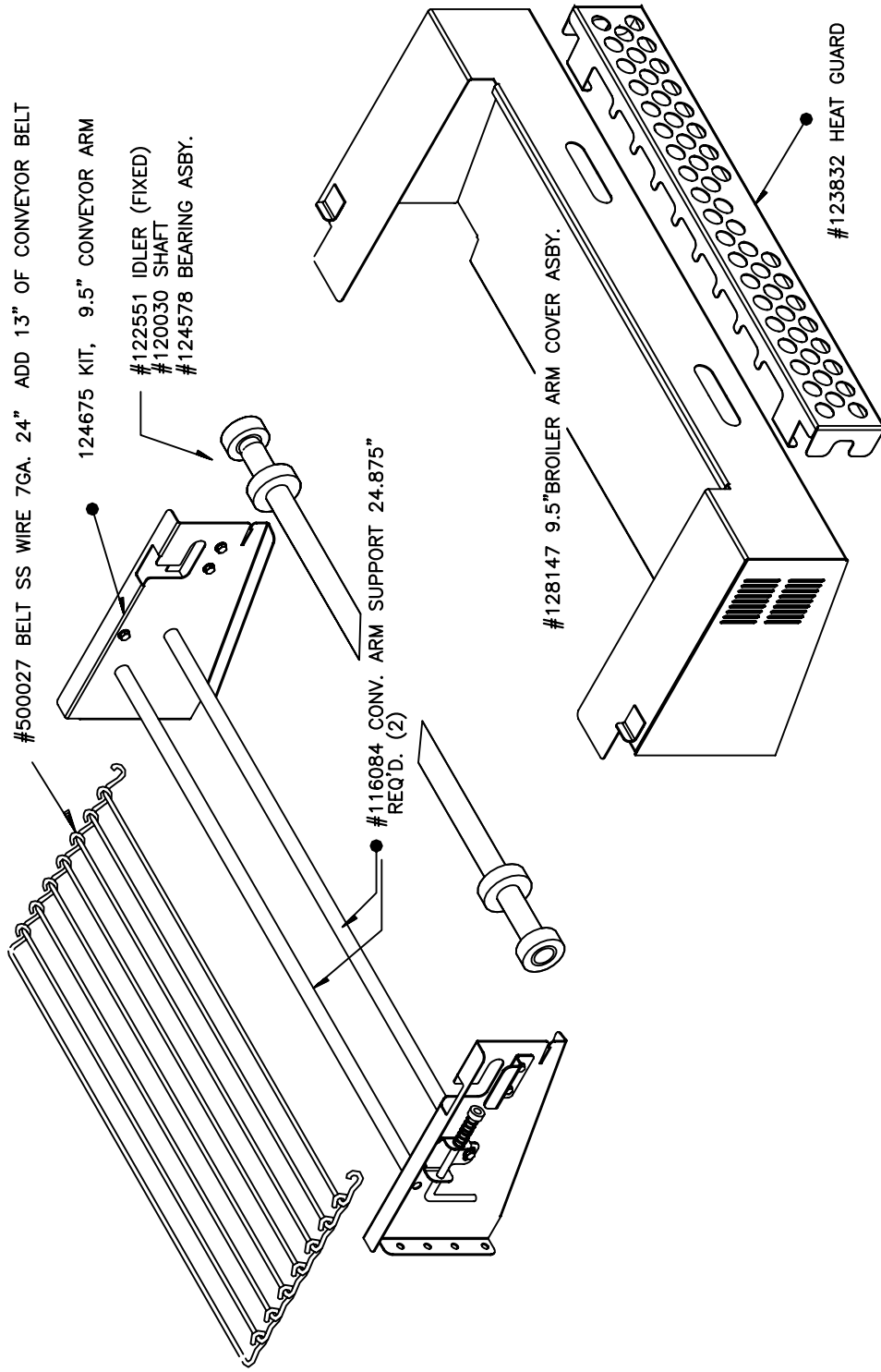

BROILER ARM EXTENSION, 9 1/2" ARMS, FOR 24" CONVEYOR, BROILER MODEL 2424

BROILER ARM EXTENSION IS NOT USED IF THE BROILER HAS THE AUTOLOADER OPTION

FIGURE 8

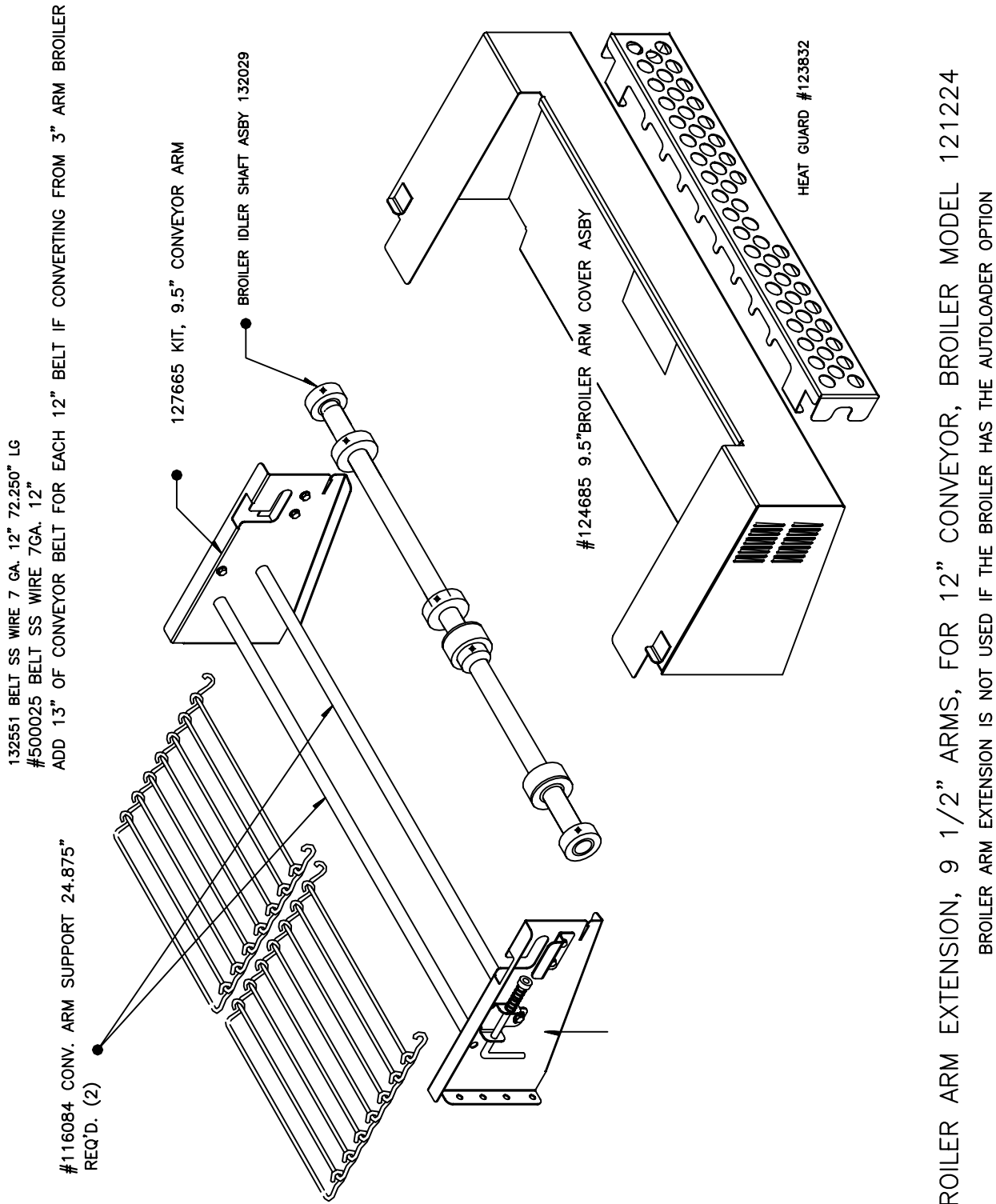

BROILER ARM EXTENSION, 9 1/2" ARMS, FOR 12" CONVEYOR, BROILER MODEL 121224
 BROILER ARM EXTENSION IS NOT USED IF THE BROILER HAS THE AUTOLOADER OPTION

FIGURE 9

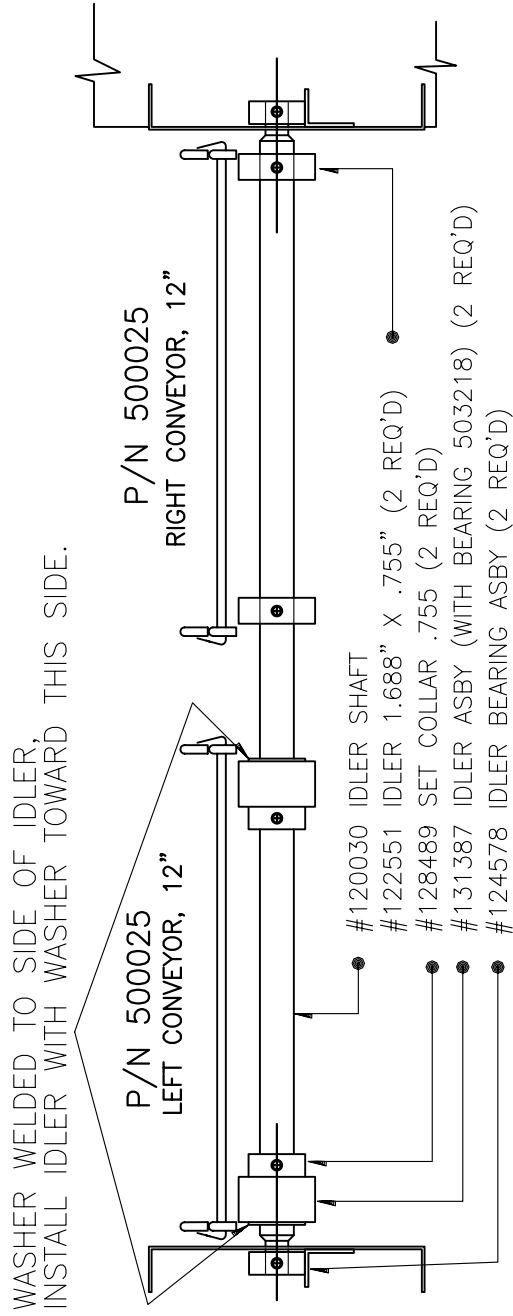

VIEW FROM LOADING END OF BROILER

BROILER IDLER SHAFT ASSEMBLY #132029
FIGURE 10

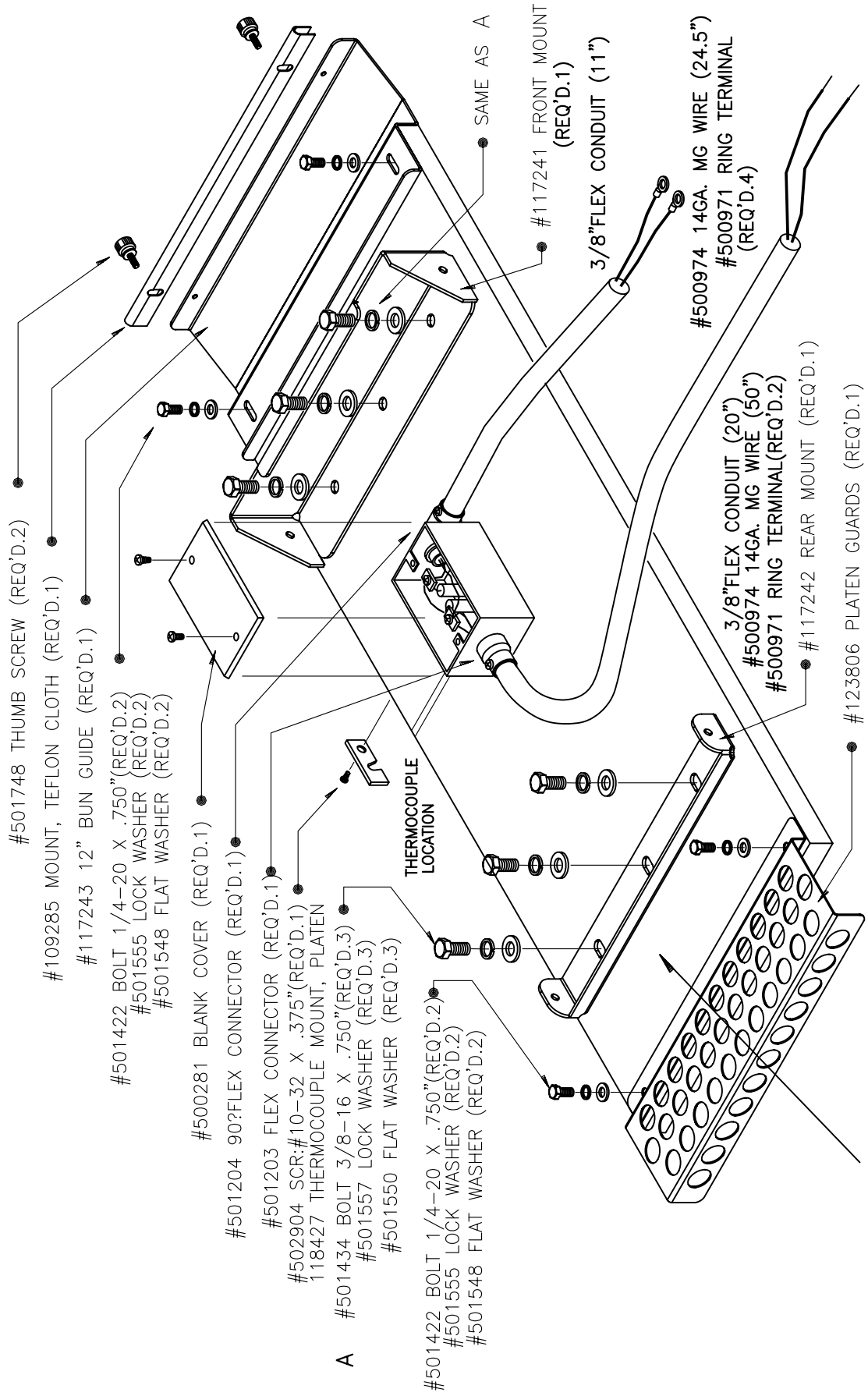

TOASTER PLATEN #501819

PLATEN ASSEMBLY, LEFT, P/N 124655

FIGURE 11

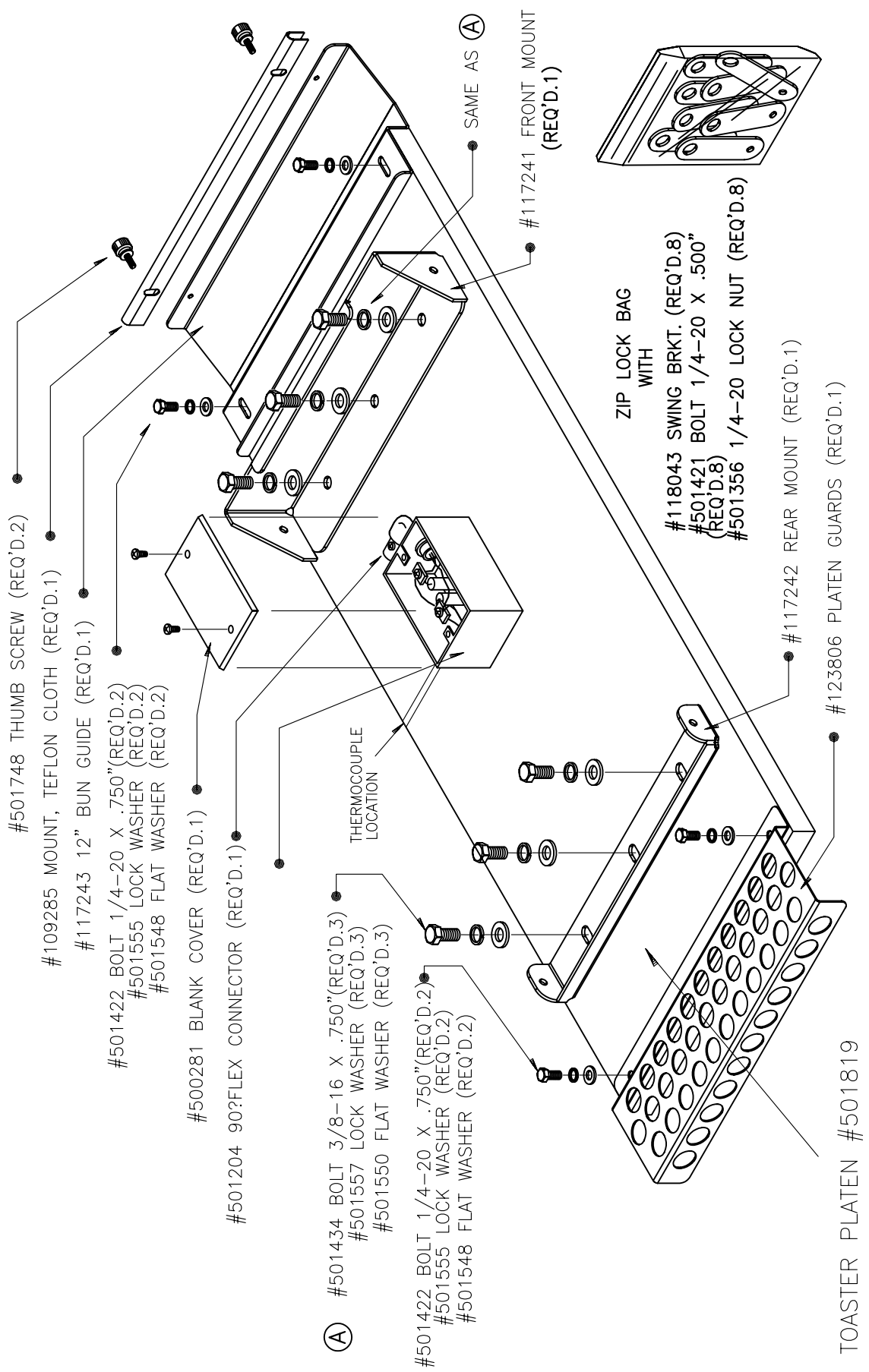

PLATEN ASSEMBLY, RIGHT P/N 124656

FIGURE 12

POWER SUPPLIED TO CIRCUIT BOARD,
SWITCH POSITIONS SHOWN FOR 230V
ON THESE TWO SLIDE SWITCHES

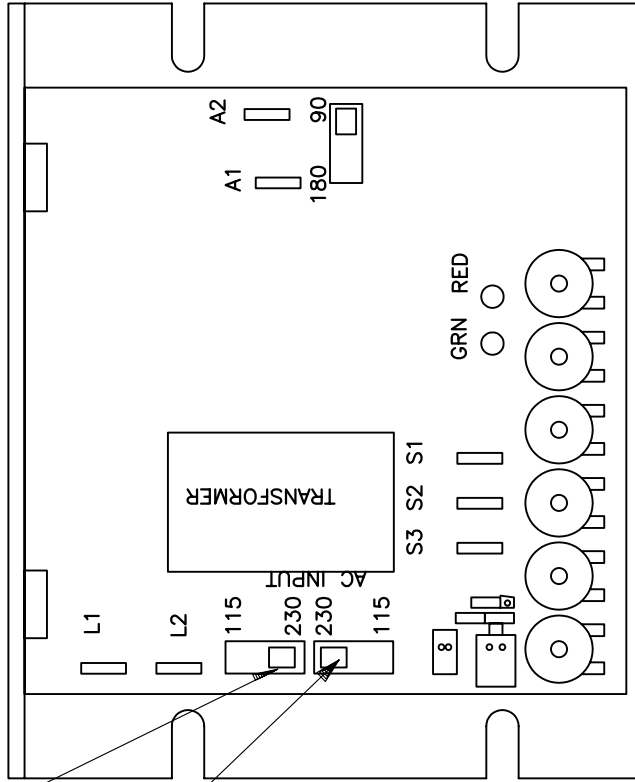

MIN MAX ACCEL DECEL TOR IR COMP
SPD SPD

MODEL MM23012D

LATE 1999 AND LATER MODELS

POWER SUPPLIED TO CIRCUIT BOARD,
SWITCH POSITION SHOWN FOR 230V
ON THIS ONE SLIDE SWITCH.

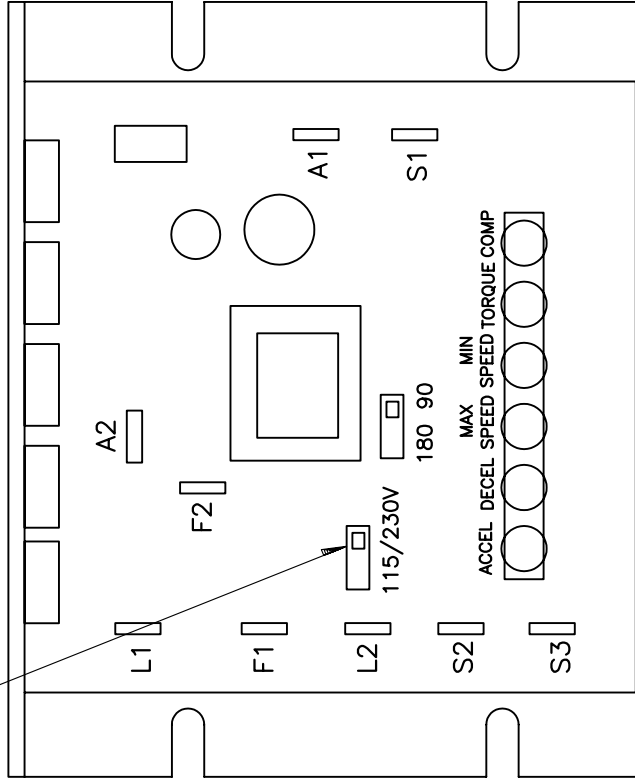

MODEL MM23011C

LATE 1999 AND EARLIER MODELS

THESE SPEED CONTROL CIRCUIT BOARDS ARE INTERCHANGEABLE IN THE BROILER,
NOTE THAT THE WIRE CONNECTION TERMINALS ARE IN DIFFERENT LOCATIONS
BUT ARE NUMBERED THE SAME. ALSO, THE NEWER MODEL HAS TWO SLIDE SWITCHES
WHICH MUST BE SET CORRECTLY FOR THE 230V INCOMING POWER SUPPLY.
THE F1 AND F2 TERMINALS WHICH WERE ON THE OLDER BOARD HAVE BEEN ELIMINATED
ON THE NEWER BOARD.

SPEED CONTROL CIRCUIT BOARD P/N 140158

FIGURE 13

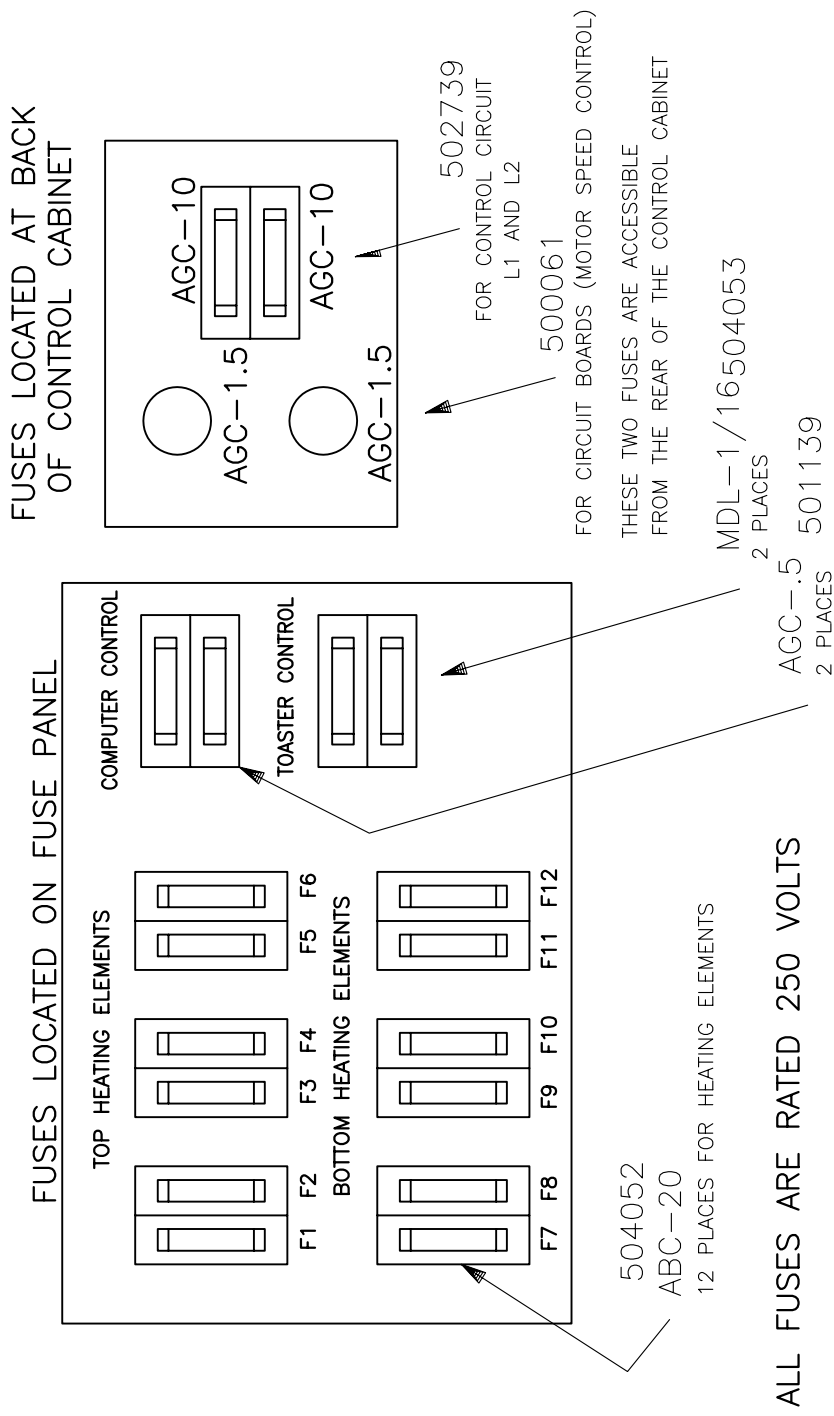

FUSES ARE LOCATED INSIDE THE CONTROL CABINET ON THE RIGHT SIDE OF THE BROILER. REMOVE THE LIFT-OFF RIGHT SIDE COVER. TWO FUSES ARE ACCESSIBLE AT THE REAR OF THE CONTROL CABINET. THE OTHER FUSES ARE LOCATED INSIDE THE CONTROL CABINET.

FUSE LOCATIONS
FIGURE 14

TOASTER PLATEN HEAT CONTROL INSTRUCTIONS

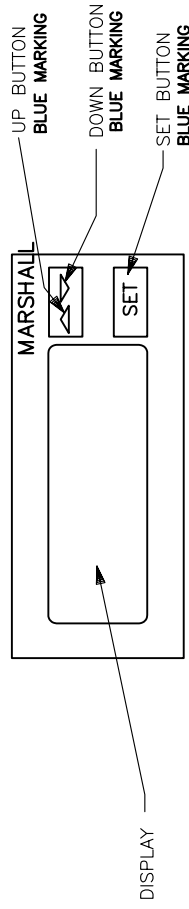

THE SET POINT IS THE TEMPERATURE THE CONTROL WILL MAINTAIN.
TO CHANGE THE SET POINT:

1. The appliance must be powered on with the temperature controller showing the current temperature in order to change the set point.
2. Press the "SET" button and hold for 3 seconds and release "SET" button. Display should show the set point. The red light should be blinking. If not, then the keyboard is locked. To unlock the keyboard, press the up and down arrows at the same time, and keep both pressed 3 seconds.
3. Use up and down arrows to select a new set point, and press SET. The new set point should blink.
4. The display will return to the current temperature. The new set point is now set.

FACTORY SET TO 425 DEG F (450 DEG F IS THE MAX TEMPERATURE ALLOWABLE)

THIS CONTROL IS LOCATED ON THE RIGHT SIDE OF THE BROILER
AND IS ACCESSIBLE BY REMOVING THE RIGHT SIDE LIFT-OFF COVER FROM THE BROILER.

TOASTER PLATEN HEAT CONTROL
FIGURE 15

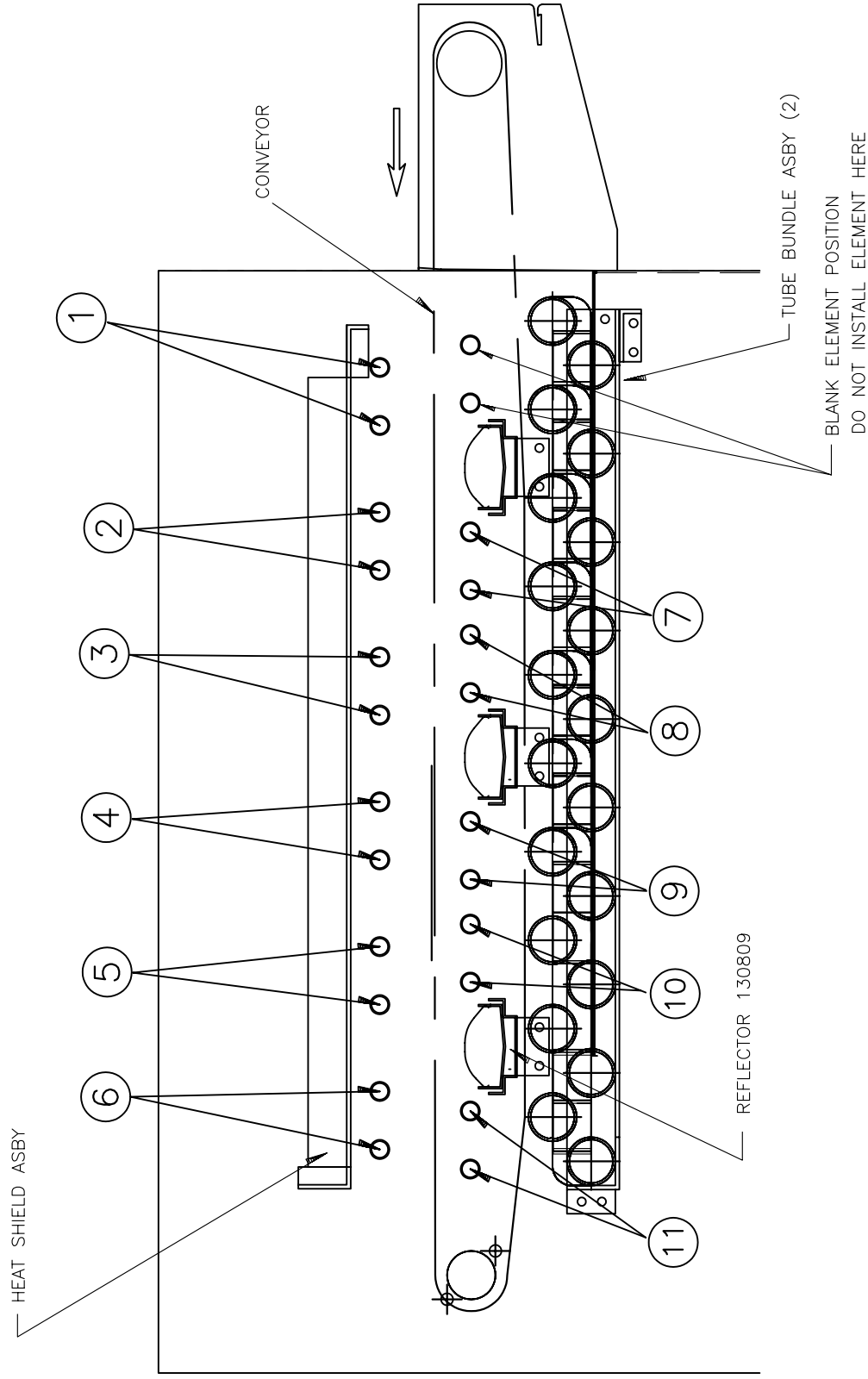

11 HEATING ELEMENTS TOTAL, 2 HAVE THERMOCOUPLE CLIPS WELDED TO THE ELEMENTS
ELEMENTS AT POSITION 2 AND 7 HAVE THERMOCOUPLES ATTACHED.

ELEMENT LOCATIONS
SECTION VIEW THRU BROILER
FIGURE 16

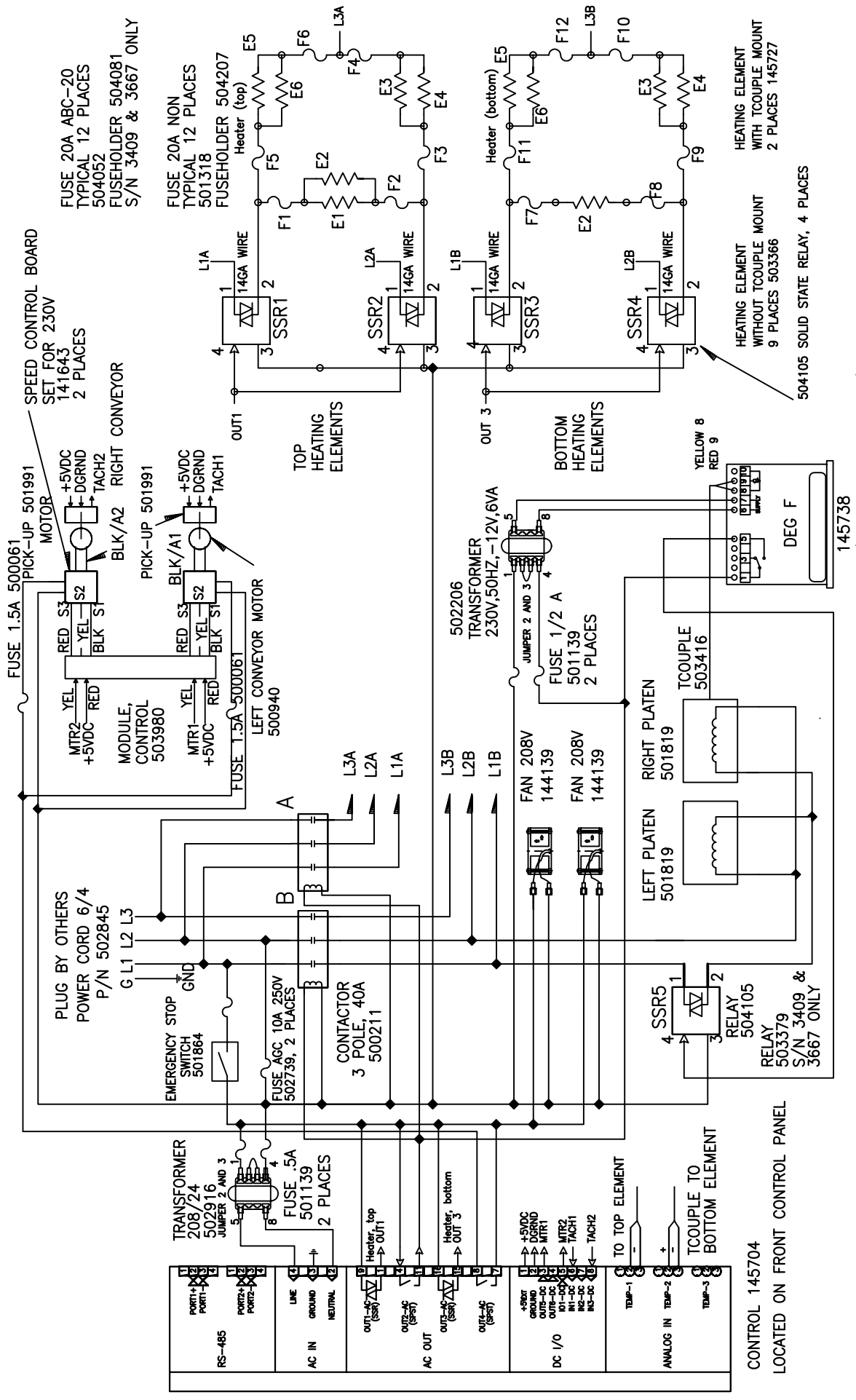

CONTROL, TEMP (FOR TOASTER PLATENS)

REV	DESCRIPTION	DATE	REV. BY	DATE	REV. DATE:
1	ADDED P/N FOR RELAY	07-OCT-2005	C.P.	22-SEP-2004	
2	ADDED MOTOR KILL	20-JUN-2006	J.L.		
3	ADDED ELEMENT FUSEHOLDER	10-JUL-2007	PW		
4	RELAY 504105 75A WAS 503934 40A	17-SEP-2007	C.P.		
5	UPDATED RELAY AND FUSE INFO	09-JAN-2009	J.L.		
6	503416 WAS 502659	20-JAN-2009	J.L.		

DRAWN BY: C.P.		DATE: 22-SEP-2004	
GENERIC NAME: SCHEMATIC		REV. DATE:	
PRODUCT LINE: BRL		PRODUCT CLASS: BRL	
SIZE: A		ROUTE: MANUF	
SCALE: 1:1		IMAGE MAY BE REDUCED	
REFERENCE		DWG. NO.: 145703	
X		REV: 6	
N/A		CODE: CP4M	

MARSHALL AIR SYSTEMS, INC.

SCHEMATIC, 121224 208V 3PH 60A WITH 6-BUTTON CONTROL

CONTROL, TEMP (FOR TOASTER PLATENS)

CONTROL PANEL QUICK GUIDE



AUTOBROIL™

