

This document contains the installation and operating instructions for:

**MODEL: FR15BG AUTOBROIL™**

FOR YOUR SAFETY

DO NOT STORE OR USE GASOLINE OR OTHER  
FLAMMABLE VAPORS OR LIQUIDS IN THE  
VICINITY OF THIS OR ANY OTHER APPLIANCE.

INSTRUCTIONS TO PURCHASER:

1. ANSI Z83.11 STANDARDS REQUIRE THAT YOU POST IN A PROMINENT LOCATION THE PROCEDURES TO FOLLOW IN THE EVENT THE USER SMELLS GAS. THIS INFORMATION SHALL BE OBTAINED FROM THE LOCAL GAS SUPPLIER.
2. THIS MANUAL NEEDS TO BE RETAINED FOR FUTURE REFERENCE.

WARNING: IMPROPER INSTALLATION, ADJUSTMENT, ALTERATION, OR MAINTENANCE CAN CAUSE PROPERTY DAMAGE, INJURY OR DEATH. READ THE INSTALLATION, OPERATION AND MAINTENANCE INSTRUCTIONS THOROUGHLY BEFORE INSTALLING OR SERVICING THIS EQUIPMENT.

# MODEL FR15BG

## TABLE OF CONTENTS

	<u>PAGE</u>
I. MACHINE SETTINGS (Quick Reference).....	2
II. MACHINE INSTALLATION.....	3
Pre-Installation .....	3
Appliance Location.....	3
Electrical Information.....	4
Gas Piping To Appliance .....	4
Pre-Operation Check.....	4-5
Lighting and Shut-Off Instructions.....	5
Performance Criteria .....	5-6
III. OPERATING INSTRUCTIONS.....	6
Broiler and Toaster Adjustment-Daily.....	6-7
Setting Temperature Controller For Proper High/Low Operation-Weekly .....	7
Setting Holding Temperature-Weekly.....	7-8
IV. SCHEDULED MAINTENANCE.....	8
Daily Cleaning Procedures.....	8
Monthly Cleaning Procedures.....	9-10
Quarterly Cleaning Procedures and Preventive Maintenance .....	10
V. TROUBLESHOOTING.....	10-14
VI. ASSEMBLY & DISASSEMBLY INSTRUCTIONS.....	14
VII. REPLACEMENT PARTS.....	14-19
LIMITED WARRANTY.....	i
WARRANTY PROCEDURES.....	ii

## ILLUSTRATIONS

FR15BG Dimensions.....	Figure 1
Exploded View.....	Figure 2
Hamburger Slide.....	Figure 3
Burner Assembly .....	Figure 4
Gas Distribution System .....	Figure 5
Conveyor.....	Figure 6
Axle Scraper.....	Figure 6
Restraining Device .....	Figure 7
Burner Shield Installation.....	Figure 8
Kit, Broiler Extension 15".....	Figure 9
Drive Sprocket Asby Set-up.....	Figure 10
Schematic.....	#114558, 114559, 117003

**I. MACHINE SETTINGS**  
**AUTOBROIL™**

**MODEL: FR15BG**

SERIAL NUMBER: \_\_\_\_\_

TYPE OF GAS: \_\_\_\_\_

BROILER HIGH/LOW TEMPERATURE SETTING: \_\_\_\_\_

GAS PRESSURE: HIGH \_\_\_\_\_ LOW \_\_\_\_\_

SPEED SELECTOR SETTING: \_\_\_\_\_

PASS-THRU TIME: \_\_\_\_\_

HOLDING TEMPERATURE SETTING: \_\_\_\_\_

START-UP TECHNICIAN: \_\_\_\_\_

START-UP DATE: \_\_\_\_\_

COMMENTS: \_\_\_\_\_

\_\_\_\_\_

\_\_\_\_\_

## II. MACHINE INSTALLATION

### PRE-INSTALLATION

1. After uncrating the Autobroil™ unit, inspect for shipping damage. Check that all control knobs are intact on the electrical cabinet front. Contact the factory if there are obvious problems. Set the unit in place and use the plastic bag to protect it from the debris and trash of building construction. DO NOT remove plug from gas inlet pipe. Leave this for the Qualified Service Company. Check that machine has not been dented or damaged by the carrier. Notify your freight carrier immediately to file a concealed damage claim, following the instructions attached to the outside of the shipping crate. Your warranty will not cover freight damage.
2. Installation must be performed by a Qualified Service Company. The term "Qualified Service Company" means any individual, firm, corporation or company which is either engaged in and is responsible for the installation or replacement of gas piping on the outlet side of the meter, or the service regulator when a meter is not provided, or the connection, installation or repair of gas appliances, who is experienced in such work, familiar with all precautions required, and has complied with all the requirements of the authority having jurisdiction.
3. A remote gas shut-off valve must be provided and interlocked to exhaust system when in operation.  
  
A gas shut-off control is located in the gas piping (behind the left side panel) for emergency shut-off of gas supply to this appliance.
4. Because this unit is power fan exhausted, it is necessary to provide adequate make up air equal to the amount removed. In addition to this, any other exhausts, flues, or air removal systems must be taken into consideration. Examples of this are heat removal fans or hot water heater flues.
5. The appliance and its individual shutoff valve must be disconnected from the gas supply piping system during any pressure testing of that system at test pressures in excess of 1/2 psig (3.45 kPa).
6. The appliance must be isolated from the gas supply piping system by closing its individual shutoff valve during any pressure testing of the gas supply piping system at test pressures equal to or less than 1/2 psig (3.45 kPa).

### APPLIANCE LOCATION

**WARNING: IF NOT INSTALLED, OPERATED AND MAINTAINED IN ACCORDANCE WITH THE MANUFACTURER'S INSTRUCTIONS, THIS PRODUCT COULD EXPOSE YOU TO SUBSTANCES IN FUEL OR FROM FUEL COMBUSTION WHICH CAN CAUSE DEATH OR SERIOUS ILLNESS AND WHICH ARE KNOWN TO THE STATE OF CALIFORNIA TO CAUSE CANCER, BIRTH DEFECTS OR OTHER REPRODUCTIVE HARM.**

1. Position Autobroil™ to properly align with exhaust hood (refer to equipment plan).
2. The hood/ventilator for the appliance should be located in accordance with the National Fire Protection Association Standard #96, "Removal of Smoke and Grease-Laden Vapors from Commercial Cooking Equipment" and any local applicable requirements.
3. For proper installation, the minimum clearance from combustible construction is 6" from sides and 6" from back.

4. Adequate clearance should be maintained to allow easy access to loading and unloading areas of the machine.
5. For servicing, unit must be moved two feet clear from all construction.

**CAUTION: KEEP THE APPLIANCE AREA FREE AND CLEAR FROM COMBUSTIBLES.**

### **ELECTRICAL INFORMATION**

1. The appliance is cord connected and requires a 120 volt, A.C., 60 HZ, Single Phase, 2 wire w/ground 15 AMP circuit or a 240 volt, A.C., 50 HZ, Single Phase, 2 wire w/ground 10 AMP circuit. Appliance must be electrically grounded in accordance with local codes, or in the absence of local codes, with the National Electrical code ANSI/NFPA No. 70-latest edition.
2. There is a Wiring Diagram located in the Owner's Manual and under the left side skin.

### **GAS PIPING TO APPLIANCE**

1. Installation of this appliance must conform with local codes, or in the absence of local codes, with the National Fuel Gas Code, ANSI Z-223.1-latest edition.
2. In Canada, this appliance is to be installed in accordance with Standard CGA B149.1 or B149.2 Installation Codes for gas burning appliances and equipment and any local applicable requirements.
3. The appliance is supplied with a 3/4" female pipe thread. The installer must make the pipe connection to the unit in accordance with the "National Fuel Gas Code," ANSI Z-223.1-latest edition. The gas line connected to the 3/4" female pipe thread cannot be less than a 3/4" pipe. The gas pressure and gas volume required by this appliance is shown on Page 6. Gas piping from source to broiler must be adequate to satisfy these requirements when all other gas appliances in the restaurant are operating at maximum demand.
4. A flexible AGA approved gas line is available. Instructions are (1) the installation shall be made with a connector that complies with the Standard for Connectors for Movable Gas Appliances, ANSI Z21.699-latest edition, and Addenda, Z21.69a-latest edition, and a quick-disconnect device that complies with the Standard for Quick-Disconnect Devices for Use With Gas Fuel, ANSI Z21.41-latest edition, and Addenda, Z21.41a-latest edition and Z21.41b-latest edition, and (2) adequate means must be provided to limit the movement of the appliance without depending on the connector and the quick-disconnect device or its associated piping to limit the appliance movement. See Figure 7 for details.
5. See Page 3, Items 5 and 6, for instructions on gas supply line pressure testing.

**CAUTION: DO NOT OBSTRUCT THE FLOW OF COMBUSTION AND VENTILATION AIR.**

### **PRE-OPERATION CHECK**

**Before lighting and operating your Autobroil™, make a quick check of critical items as follows:**

1. Remove both side panels and check to see that all parts are in place and that none are damaged.
2. Start conveyor chain and check for proper operation. The conveyor chain should run free and not be catching on anything.

3. The speed of the conveyor chain should be modulated from low to high, and back again without the chain stopping.
4. Before first use, and after any special cleaning, it is necessary to "season" the broiler chain. This is done by bringing chain to operating temperature and then (with burner still lit) applying liquid shortening from a saturated cloth over the full width of the broiler chain while the chain makes 5 or 6 complete revolutions.
5. Check that gas pressure at appliance is correct (see Performance Criteria on Page 6).
6. Check that grease pan is in place under unit (Figure 1).
7. Check that all parts are installed on the unit (see Figure 10).

### **LIGHTING INSTRUCTIONS FOR ELECTRONIC IGNITION SYSTEM**

1. Turn exhaust system on.
2. Make sure filters are in place in the hood.
3. Turn conveyor chain on and set speed at approximate mid-point.
4. Remove left side cover.
5. Turn gas control switch on top of Honeywell valve to "ON".
6. The broiler heat switch on the control panel will now cycle the burners on and off. Set broiler temperature controller on left side of control cabinet to (204°C) 400°F (see Item 3 of setting temperature controller on Page 7).
7. Turn on heat switch. Ignition is electronic (does not require manual lighting of pilot).
8. If pilot flame or burners fail to light turn heat switch off and wait five minutes before attempting to relight.

### **SHUT-OFF INSTRUCTIONS**

1. Turn heat switch off.
2. Wait 30 minutes.
3. Turn conveyor switch off.
4. Turn ventilator off.

### **PERFORMANCE CRITERIA**

1. The manifold pressure for each burner and appliance inlet pressure and gas amount is listed below:

<b>Type of Gas</b>	- Natural or Propane
<b>Pressure at the Appliance</b>	- 6.0-10.0 IWC for Natural
	- 11.0 IWC for Propane

- Manifold Pressure**
  - Low 4.0 IWC; High 5.0 IWC for Natural
  - Low 7.0 IWC; High 10.3 IWC for Propane
- Total Gas Amount**      \*\*      - 61,000 BTUH @ 100% High Fire

Manifold pressure is measured by a pressure gauge on the outlet side of the Honeywell gas valve. With the unit on for at least twenty minutes and the broiler temperature controller set at (204°C) 400°F (see Item 3 on Page 7), the pressure should be at 4.0 IWC (7.0 IWC for propane). With the broiler temperature controller set for (427°C) 800°F the high fire pressure is 5.0 IWC (10.3 IWC for propane). High pressure is adjusted using the regulator in the top of the gas safety valve. Low fire is adjusted using the gas pressure regulator. See Figure 5 for gas system layout.

2. The burners in the appliance are a special infrared type. All of the air for combustion must be injected through the Venturis. This makes orifice design and alignment very critical. The orifice design, in combination with the correct natural or propane gas pressure will result in adequate air aspiration and mixing. There are no air shutters. No air adjustment is needed. The proper orifice part numbers are found in Section VII - Replacement Parts.

**CAUTION: DO NOT STACK BOXES OR IN ANY WAY BLOCK AREA IN IMMEDIATE VICINITY OF VENTURIS OR IN ANY OTHER WAY OBSTRUCT FLOW OF COMBUSTION AIR.**

3. Pilot burner flame is fixed and is not adjustable.
4. All burners will be bright orange when burning properly. If a dull red is observed after 30 minutes of warm-up with a blue flame above the burner face, the orifice is not aligned properly. "Popping," or burning back at the orifice of the burner, is a result of the burner screen being loose or a faulty gasket under the burner screen. LP machines may exhibit a light "popping" sound when the unit is turned off; this is normal.

**NOTE: IF BURNER SCREEN IS TORN OR HAS A HOLE, OR IF A GASKET IS LEAKING, THE BURNER MUST BE REPAIRED. See Figure 4.**

### III. OPERATING INSTRUCTIONS

#### BROILER ADJUSTMENT - DAILY

#### LIGHTING INSTRUCTIONS FOR ELECTRONIC IGNITION SYSTEM

1. Turn exhaust system on.
2. Make sure filters are in place in the hood.
3. Turn conveyor chain on and set speed at approximate mid-point.
4. Remove left side cover.
5. Turn gas control switch on top of Honeywell valve to "ON".

6. The broiler heat switch on the control panel will now cycle the burners on and off. Set broiler temperature controller on left side of control cabinet to (204°C) 400°F (see Item 3 of setting temperature controller on Page 7).
7. Turn on heat switch. Ignition is electronic.
8. If pilot flame or burners fail to light turn heat switch off and wait five minutes before attempting to relight.

#### **SHUT-OFF INSTRUCTIONS**

1. Turn heat switch off.
2. Wait 30 minutes.
3. Turn conveyor switch off.
4. Turn ventilator off.

#### **SETTING TEMPERATURE CONTROLLER FOR PROPER HIGH/LOW OPERATION-WEEKLY**

1. Follow the procedure in Step 3 on Page 7 in order to set temperature control for (204°C) 400°F. After doing this, turn on the broiler.
2. Allow the broiler burners and conveyor chain to warm up for 60 minutes (with the chain at approximately the correct speed).
3. Observe the temperature displayed: push "SET" and release to view the "SET POINT." To change set point push "SET" and, within three seconds, use the arrows to select a new set point. When setting the High/Low for proper operation, make the set point THE SAME as the observed temperature made after the sixty minute warming. Broiler High/Low control is now set. The setting should be between (274°C) 525°F and (343°C) 650°F. If not at least (274°C) 525°F, the high and low gas pressures, as discussed on Page 6 under Performance Criteria, may require adjustment or the hood exhaust may be excessive. The broiler will work but will cook slower.
4. Place one meat patty on the broiler chain. Based on the appearance of the broiled patty, reset the Digital Speed Control for the desired broiling quality. (Note: this single patty should be cooked to the maximum degree of the Minimum/Maximum doneness tolerance.)

**NOTE: THE HIGHER THE NUMERICAL VALUE SET ON THE DIGITAL SPEED CONTROL, THE FASTER THE CONVEYOR CHAIN WILL RUN.**

#### **SETTING HOLDING TEMPERATURE-WEEKLY**

1. The temperature controller on the front of the unit has been preset at (90°C) 195°F. Push and release the "SET" button to observe the set point. If this setting has been inadvertently changed, it is necessary to reset the proper value. This may be done using the arrows on the control within three seconds of pushing and releasing the "SET" button. Afterwards the actual temperature is displayed.

## IV. SCHEDULED MAINTENANCE

### DAILY CLEANING PROCEDURES

**CAUTION:** Do not touch the broiler section immediately after appliance shut-down. The temperature inside enclosures is in excess of (260°C) 500°F, which eliminates the need to clean any parts inside the enclosures for sanitary purposes. Any grease that may build up on the exterior of the enclosures should be cleaned off with a damp cloth and a minimum amount of detergent. **Never use a large amount of water on the enclosure or allow burner faces to get wet as this could cause premature burner or gasket failure. Disconnect the power supply to the appliance before cleaning or servicing.**

**CAUTION:** ~~Under no circumstances should oven cleaner be used on this appliance. IT WILL EAT HOLES IN THE ALUMINUM GAS VALVES AND GAS LINES, CAUSTIC FUMES CAUSE ELECTRICAL COMPONENT DAMAGE, AND WILL CAUSE MANY OTHER PROBLEMS IF USED TO CLEAN THIS BROILER.~~

**CAUTION: KEEP THE APPLIANCE AREA FREE AND CLEAR FROM COMBUSTIBLES.**

1. Allow broiler burners and chain to operate for 30 minutes after cooking last patty to burn off excess grease on broiler components. Then turn the unit off and allow to cool. (This applies every time a meat chain is turned off - regardless of what time of day meat chain is shut down - and regardless of how few patties were broiled in the last 30 minutes, last hour, etc.) This will clean some parts of the cooking chamber. Failure to perform this procedure daily will result in poor cooking times.
2. Remove all exterior panels except those which are attached with screws. Be careful not to touch any hot internal broiler components.
3. Remove burners from right side of unit and shake all debris off burners after they cool. **DO NOT WASH BURNER AS IT WILL DESTROY GASKET.** Brush surface of burner mesh with soft brush.
4. Remove lower burner shields as shown in Figure 8. Brush or scrape residue.

<b>WARNING:</b>	<b>THE BURNER AND REVERBERATING SCREENS (LOCATED UNDER THE TOP BURNERS), ARE MADE FROM INCONEL METAL MESH. THIS MATERIAL DETERIORATES WITH USE. INSPECT THESE SCREENS DAILY AND REPLACE IF SCREEN IS SEVERELY CORRODED. FAILURE TO DO SO CAN RESULT IN METAL PARTICLES BEING SERVED TO YOUR CUSTOMERS.</b>
-----------------	--

5. Remove the following items and wash with hot soapy water.

	Tunnel Guard Front	Figure 2
*	Conveyor Cover	Figure 2

	Rear Tunnel Plate	Figure 2
	Meat Stripper	Figure 2
*	Holding Lid	Figure 2
*	Broiler Spatula	Figure 3
*	Make Up Tray Insert	Figure 3
*	Burger Tray & Stop Assembly	Figure 3
	Slide Insert	Figure 3
*	Wire Rack	Figure 3
*	Grease Pan	Figure 1
	Conveyor Wiper	Figure 2
* NOTE: these items may be removed during the 30 minute period.		

6. With the conveyor switch ON and heat switch **OFF**, wire brush the broiler conveyor and, as it cools, wipe with damp cloth.
7. Scrape deposits from the axles with the axle scraping tool, furnished with each machine as shown in Figure 6.
8. The slide surface (Figure 3) is covered with a teflon sheet. Daily cleaning is necessary. To clean: Remove slide assembly, then remove teflon sheet by loosening (DO NOT REMOVE) thumb screws on slide (see Figure 3). Gently wash and rinse sheet with warm water and a mild liquid detergent. Don't scrub sheet with coarse materials. All washing should be done on a flush smooth surface, taking care not to fold, crease, or cut the teflon sheet. **DO NOT USE A DEGREASER ON THE TEFLON SHEET. THE TEFLON SHEETS' USEFUL LIFE WILL BE GREATLY REDUCED IF A DEGREASER IS USED.**
9. Remove grease and meat residue from any part of remaining broiler structure where visible. Use a damp cloth with detergent and a putty knife for best results.
10. After cleaning all removable parts as noted, allow to dry and reassemble.

#### **MONTHLY CLEANING PROCEDURES**

1. Turn off gas control knob and disconnect electricity.
2. Remove upper burners, lower burners and screens (only used on natural gas units). These parts are illustrated in Figure 2.
3. Spread conveyor links open with screwdriver or chain pliers (part #500033). Lift front axle up to make slack in the conveyor belt, unhook conveyor chain and remove to gain access to lower cooking chamber for cleaning side walls.

4. Remove and clean lower burner shields as shown in **Figure 8**. This can best be accomplished with a scraper.
5. Blow out all four (4) burners through the venturi opening. **CAUTION: Do not drop burners or get wet as this may break gasket or add to premature burner failure.**
6. Reassemble conveyor chain. Make certain it is not on backward (**Figure 6**) and **CLOSE** open links to match other links.
7. Using a damp cloth, wipe the inside of each burner venturi.
8. Reinstall burner screens, lower burner shields, and burners.

#### **QUARTERLY CLEANING PROCEDURES & PREVENTIVE MAINTENANCE**

1. Remove conveyor and soak in hot soapy water overnight. The chain is removed by lifting axle up to produce slack and separating as described in Item 3 above. When replacing chain, make certain the conveyor is installed per **Figure 6**. **PLACING CHAIN ON BACKWARD WILL CAUSE SEVERE BINDING PROBLEMS.** **CLOSE** open links to match other links.
2. Lubricate the roller (drive) chain with a few drops of any grade motor or machine oil.
3. Remove and inspect all motor brushes and replace if less than 1/4" is left.
4. Do not remove internal gas lines for cleaning.
5. Clean gas orifices:
  - Orifices are passageways directing gas flow into burner. Uneven gas flow or air to gas ratio is caused by dirty or damaged orifices.
  - Orifices are made of brass. Use special care in cleaning—don't gouge or make gas holes bigger.
  - To reach orifices, remove burners.
  - Use a pipe cleaner dipped in rubbing alcohol to clean orifices. Swab until clean; free of carbon build-up. Do not use drill bit; this damages orifice.
6. **INVENTORY THE SPARE PARTS KIT AND ORDER MISSING PARTS AS NEEDED. KEEP A COMPLETE SET OF PARTS ON HAND AT ALL TIMES.**

#### **V. TROUBLESHOOTING**

**This section contains a list of possible problems with the Autobroil™ unit. ALL ELECTRICAL TROUBLE SHOOTING INVOLVING ACCESS INTO THE MOTORS OR ELECTRICAL ENCLOSURES MUST BE PERFORMED BY A QUALIFIED ELECTRICIAN. All items marked with asterisks (\*) should be performed by service agency qualified to perform service on gas fired appliances.**

1. **PROBLEM: BURNER BACKFIRES.** Flashback, blue flame at entrance to burner makes motor-boating sound like a blow torch. **IMPORTANT:** If burner backfires, turn it off. Continued operation will cause damage to the entire burner.

POSSIBLE CAUSE:

- \* A) Burner screen failure (hole) or burner gasket. **SOLUTION:** Replace burner screen or gasket (Figure 4).
- \* B) Burner over-fired - manifold pressure too high. **SOLUTION:** Check and reset gas control regulator to give rating plate value for manifold pressure (shown under Performance Criteria on Page 6). Wait 5 minutes & relight. Flashback will not occur immediately unless a large opening in or around the burner screen is evident. Wait an hour after relighting to check that problem is solved. Figure 5 illustrates which regulator sets high and low gas pressures.

**2. PROBLEM: FLAMES VISIBLE AT EXHAUST STACK OR IN CHAMBER.**

POSSIBLE CAUSE:

- \* A) Low gas pressure. **SOLUTION:** Check and reset gas control regulator to give rating value for manifold pressure (shown under Performance Criteria on Page 6. Figure 5 illustrates which regulator sets high and low pressures.

**3. PROBLEM: PILOT FLAME GOES OUT AFTER 90 SECONDS OF IGNITION TRIAL.**

POSSIBLE CAUSE:

- \* A) Pilot assembly dirty or bent. **SOLUTION:** Check for bent pilot gas line and/or dislodge debris.
- \* B) Low gas pressure. **SOLUTION:** Increase gas pressure to appliance (see Figure 5).
- \* C) Pilot orifice clogged. **SOLUTION:** Dislodge debris or replace orifice.

**4. PROBLEM: BURNER WILL NOT LIGHT AT ALL.**

POSSIBLE CAUSE:

- \* A) Orifice. **SOLUTION:** Check that orifice is not plugged. (If it is necessary to change the orifices, new ones must be ordered from the factory.)

**\* INSTRUCTIONS MARKED WITH ASTERISKS SHOULD BE PERFORMED BY AUTHORIZED SERVICE PERSONNEL.**

- B) Check that flame runner is fully lit. **SOLUTION:** If not, clean flame runner orifice or remove and clean flame runner. Refer to Figure 2.
- C) Pilot. **SOLUTION:** Pilot must light and stay lit in order for burner to light. Check pilot problem list (see Item 3 on Page 11).
- \* D) Gas Solenoid. **SOLUTION:** Check that solenoid valve on main gas valve is working.

**5. PROBLEM: CONVEYOR CHAIN WILL NOT MOVE.**

POSSIBLE CAUSE:

- A) Check 10 amp fuse. **SOLUTION:** Replace if blown.

- B) Check for object caught in conveyor, causing a jam. **SOLUTION:** Remove object.
- D) Check to see if motor shaft is moving. **SOLUTION:** Sprocket needs to be tightened.
- \* E) Check rocker switch to make sure power is flowing through it. **SOLUTION:** Replace switch.
- \* F) Connect motor control leads to an operating motor speed control board. **SOLUTION:** If motor runs, replace motor control board. If motor still does not run, replace motor.

**6. PROBLEM: NO SPEED CONTROL ON CONVEYOR.**

POSSIBLE CAUSE:

- \* A) Either the speed control board, potentiometer or motor has failed. **SOLUTION:** Perform the following steps: connect the wires from the board on the broiler to the spare circuit board. If there is still no control, the potentiometer for the conveyor has failed.
- \* B) If connecting the wires into the spare board does make it work, then the circuit board has failed.
- \* C) If neither of the above works, then the motor has failed. Perform the check under Item 5F on Page 12.

**7. PROBLEM: REPEATED MECHANICAL BINDING.**

POSSIBLE CAUSE:

- A) Check to see that chain is not on backward. **SOLUTION:** See proper chain installation on Figure 6.
- B) Inspect chain closely for bent or warped links that may be snagging and causing a binding condition. Also check that the chain links are not climbing out of the sprockets as the conveyor rotates. **SOLUTION:** Straighten or replace bad links.
- \* **INSTRUCTIONS MARKED WITH ASTERISKS SHOULD BE PERFORMED BY AUTHORIZED SERVICE PERSONNEL.**
- C) Make sure the axle assembly is clean and free of grease and food residue to allow smooth movement of the conveyor. **SOLUTION:** Clean axle. See Figure 6.
- D) Check the axle assembly to make certain all set collars, bearings, etc. are properly positioned and secure.
- E) Disassemble conveyor axle assembly and check condition of bushings and bearings for excessive wear. **SOLUTION:** Replace if worn or damaged.
- F) Visually inspect the motor drive chain assembly for smooth rotation of chain. **SOLUTION:** Make certain there are no binding or worn components.
- G) Make sure conveyor is not catching on meat stripper. **SOLUTION:** Reposition stripper by adjusting mounting bracket or straighten bent stripper. See instruction 5 on page 14.

H) Check that axle adjusting screw is not too tight. **SOLUTION:** Loosen so chain is not excessively tight.

**8. PROBLEM: HOLDING TEMPERATURE WILL NOT REACH (90°C) 195°F.**

POSSIBLE CAUSE:

- \* A) Check that overhead ThermoGlo™ is hot. **SOLUTION:** Replace element after making sure element is receiving power.
- \* B) Check element connections on bottom heating element.
- \* C) Using a surface thermometer on top of platen, check that temperature controller is allowing platens to heat to the desired temperature.
- \* D) The temperature sensor attached to the bottom heated plate has failed. This condition causes the controller to flash "EEE" or "999". **SOLUTION:** Check to be sure sensor leads are securely fastened to temperature controller. If so, then replace sensor.

**9. PROBLEM: HIGH/LOW CONTROL DOES NOT WORK.**

POSSIBLE CAUSE:

- A) Determine gas pressure by checking gas pressure gauge. **SOLUTION:** Adjust per instructions on Page 6.
- B) If unit stays in high or low, check that control is properly set for about (399°C) 750°F. **SOLUTION:** Reset to proper temperature as shown in Item 3 on Page 8.
- C) If control flashes "EEE" or "999", then inspect thermocouple. **SOLUTION:** Check to be sure sensor leads are securely fastened to temperature controller. If so, then replace sensor.
- \* **INSTRUCTIONS MARKED WITH ASTERISKS SHOULD BE PERFORMED BY AUTHORIZED SERVICE PERSONNEL.**

**10. PROBLEM: HAMBURGERS WILL NOT FALL CORRECTLY.**

POSSIBLE CAUSE:

- A) Check for build-up of black residue on teflon sheet caused by lack of and/or improper cleaning. **SOLUTION:** Clean teflon sheet at least daily (See Item 7, Page 9).
- B) Teflon sheet is worn or damaged. **SOLUTION:** SHEET MUST BE REPLACED.
- C) Meat stripper is dirty or adjusted too far from conveyor (Figure 2). **SOLUTION:** Clean and reposition near chain by moving brackets that hold stripper. See instruction 5 on page 14.

## VI. ASSEMBLY & DISASSEMBLY INSTRUCTIONS

1. The burner screen (Figure 4) may be replaced by removing the six screws from both sides of the burner housing. The assembly will then slip out. Remove all old gasketing and replace it as shown. Compress the new assembly into the burner housing with hand pressure all around the outside of the burner housing. Next, place the assembly on a flat strong surface, such as a cement floor, and push the burner housing down so as to drive the screen frame into the housing. Insert new screws and snug the screws in a staggered sequence. Do not over tighten screws. While pushing on the back of the burner housing with one hand, drive the screws in until the head of the screw comes in contact with the burner housing. These screws will keep the frame tight against the gasket.

**NOTE: IT IS IMPORTANT THAT THE NEW GASKET BE HELD IN PLACE WHILE ATTACHING NEW SCREEN ASSEMBLY. THIS IS EASILY ACCOMPLISHED BY RUBBING A SMALL AMOUNT OF PETROLEUM JELLY ALONG THE INSIDE LIP OF THE BURNER HOUSING.**

2. The restraining device is a separate line and should be anchored no less than 6" away from the gas connector and in a parallel position to the flexible line. The following instructions refer to Figure 7. By using the adjusting clips (1) alter the length of the cable (2) so that the overall length (3) is 3" to 6" shorter than the length of the flexible gas line including the fitting. Then attach staple (4) to an existing wall or other structurally sound surface. Attach scissor hook (5) to staple and secure with cotter pin. Finally attach spring hook (6) to gas appliance as shown in Figure 7. Make certain that the overall length of the restraining line is shorter than the gas line so no strain is placed on the gas line or piping when moving the unit.
3. When replacing the thermocouple which attaches to the temperature controller, make certain it is inserted through side wall of machine into cooking chamber exactly one inch (1").
4. Follow the procedures shown in Figure 8 for removing and cleaning lower burner shields.
5. To properly set the clearance between the meat stripper and the conveyor chain, the machine must be HOT. Loosen the bolts holding the brackets to the sides of the unit and adjust their position until the top edge of the stripper is within 1/16" of the hot conveyor.

**WARNING: THIS APPLIANCE IS NOT CAPABLE OF BEING SAFELY PLACED INTO OPERATION DURING A POWER FAILURE AND NO ATTEMPT TO OPERATE IT SHOULD BE MADE.**

## VII. REPLACEMENT PARTS-FR15BG

When ordering parts, make sure to specify the machine model number, type of gas and serial number as shown by the label attached to the right side cover.

PARTS	DESCRIPTION	FIGURE
101357	Bearing	2, 10
101978	Burner Gasket	4

104679	Conveyor Cut Link 15"	6
106476	Burner Frame Assembly	4
110042	Fan	Schematic
111984	Grid Screen Retainer	2
114272	Owner's Manual	N/A
114551	Temperature Control-Holding	2,Schematic
114555	Burner Cover	2
114560	Temperature Control (High/Low Gas)	2,Schematic
115354	Top Burner Mount	2
115357	Slide Insert	3
115361	Tunnel Guard Front (Optional with "CHICKEN" wording")	2
115367	Burner Assembly	2,4
115380	Make Up Tray Insert	3
115381	Conveyor Cover	2,10
115403	ThermoGlo™ Assembly	Schematic
115405	Axle Drive	2
115407	Side Skin Asby	2
115412	Holding Unit Element	Schematic
115416	Tunnel Guard Front (without "CHICKEN" wording")	2
115425	Meat Stripper	2,10
115642	Burner Grid Screen	2
115660	Spacer	2
115668	Spare Parts Kit	N/A
115682	Conveyor Wiper Assembly	2,10
115694	Burger Tray & Stop Assembly	3,10
115695	Broiler Spatula	3
115709	Rear Tunnel Plate	2,10
115794	Teflon Grip	3
115800	Holding Lid	2,10

115803	Teflon Cloth 16"X27"	3
116024	Wire Rack	3
116052	Lid Catch	2
116056	Pilot Mount	N/A
116100	Flame Runner Assembly (Bottom Burners)	2
116101	Flame Runner Assembly (Top Burners)	2
116103	Burner Housing	4
116126	Thermocouple Fitting	N/A
116129	Scraper Axle	6
117199	Meat Stripper Bracket (Pair)	2
117216	Conveyor Wiper	2,10
117228	Control Guard	2
118025	Burner Shield	2,8,10
118731	Plate back up, bearing	10
120083	Axle, Drive .750 x 23.5	10
123803	Burner Clamp Assembly	4
124578	Bearing Retainer Assembly	2
124642	Sprocket Asby, 5010 x .755" 502395 W/ Cone Set	10
125650	Drive Asby, Sprocket Set-up	10
126451	Sprocket, #3518 x .755" (Conveyor Drive)	N/A
128320	Washer, 1.000" OD x 0.765" ID	10
130224	Kit, Broiler Extension 15" (Optional)	9
130657	Kit, Motor Reversing	N/A
500001	Burner Screw	4
500026	Conveyor 15" (Per Foot)	6
500033	Pliers Chain Conveyor	6
500035	Chain Roller #35	N/A
500040	Sprocket #3510 X .500" (Motor)	10
500063	Fuse 10 Amp	Schematic

500067	Fuse Block	Schematic
<a href="#">500070</a>	Gas Gauge (Natural)	5
500071	Gas Gauge (LP)	5
<a href="#">500083</a>	Link Half (Drive Chain)	N/A
<a href="#">500112</a>	Digital Pot (Optional)	2
<a href="#">500118</a>	Set Collar 3/4"	2, 10
500174	Gas Line Flex 36" With Restraint Dormant	7
<a href="#">500186</a>	Gas Regulator VR-48 (Natural)	5
500187	Gas Regulator VR-48 (LP)	5
500294	Terminal Strip 6 Pole	N/A
500336	Gas Line Restraining Device RD-36	7
<a href="#">500340</a>	Terminal Strip 3 Pole	N/A
500657	Bell Reducer 3/4"-1/2"	5
500811	Tool Box	N/A
<a href="#">500940</a>	Drive Motor	10,Schematic
500941	Motor Brushes	Schematic
501012	Thumb Screw 1/4--20	3
501614	Module Ignition (Electronic Spark)	Schematic
501624	Circuit Board	Schematic
<a href="#">501723</a>	Pilot Head Igniter (Natural)	Schematic
<a href="#">501747</a>	Transformer 120V - 24V	Schematic
501757	Handle Insert	N/A
501762	Pilot Head Igniter (LP)	8
501835	Grease Pan	1
<a href="#">501864</a>	Switch	2,Schematic
<a href="#">502075</a>	Cord (Domestic)	Schematic
<a href="#">502169</a>	Sensor	Schematic
502188	Gas Valve (Natural)	5
502189	Cable Pilot Head	Schematic

502197	Thermocouple Type K	2, Schematic
502202	Gas Valve (LP)	5, Schematic
502248	Transformer 120V-12V	Schematic
502261	Pipe Corrugated X 7" (3/8" Fl. X 3/8" Fl.)	N/A
502347	Pipe Corrugated X 17" (3/8" Fl. X 3/8" Fl.)	5
502349	Pipe Corrugated X 26" (3/8" Fl. X 3/8" Fl.)	N/A
502531	Spring Latch	N/A
502611	Solenoid Valve 120 Volt Coil	5, Schematic
502632	Gas Flex-Tube (5/8") x 30"	2
502892	Potentiometer, Rotary	2
503413	Kit, Control Temp Faceplate Deg F Ref: 132574	N/A
PART#	DESCRIPTION	FIGURE
<b>NATURAL GAS ORIFICES</b>		
500102	Orifice #50 (Top Burners)	N/A
500879	Orifice #47 (Bottom Burners) AE9E	N/A
500884	Orifice #48 (Bottom Burners) AE9	
501729	Orifice Flame Runner #74 (Bottom Burners)	N/A
501709	Orifice Pilot Burner	N/A
501718	Orifice Flame Runner #70 (Top Burners)	N/A
<b>LP GAS ORIFICES</b>		
124582	Burner, Gasket 1/4"	4
500928	Orifice #57 (Bottom Burners)	N/A
500928	Orifice #57 (Top Burners)	N/A
501710	Orifice Pilot Burner	N/A
502661	Orifice Flame Runner #78 (Bottom Burners)	N/A
502661	Orifice Flame Runner #78 (Top Burners)	N/A

PART#	DESCRIPTION	FIGURE
<b>240V 50 HZ 1 PHASE PARTS</b>		
117006	ThermoGlo™ Element	Schematic
117007	Holding Unit Element	Schematic
501953	Cord (European)	Schematic
501958	Fan Transformer 240 V 50 HZ	N/A
502168	Transformer 240 -12	Schematic
502575	Solenoid Valve	5,Schematic
502916	Transformer 230 - 24	Schematic 500186

# BROILER LIMITED WARRANTY

MARSHALL AIR SYSTEMS, INC., ("Marshall") warrants to the first purchaser ("Purchaser") all new equipment of its manufacture to be free of defects in material and factory workmanship for a period of one year\* from date of shipment provided that (i) the equipment is installed in the Continental United States, Canada or Hawaii and operated according to the Owner's Manual while located at the original address of installation, (ii) the warranty registration card has been completed and returned to the factory within fifteen (15) days after installation, and (iii) a post-installation start-up has been performed by an authorized service representative (portable equipment not applicable). Marshall's obligation under this warranty is limited to the repair or replacement at its option of any defective part. Under certain circumstances, Marshall will reimburse Purchaser for limited labor costs in replacing parts during a period of not more than ninety (90) days after date of shipment, provided that Labor Reimbursement instructions are followed and items i, ii, and iii above are completed. See special provision for portable equipment. It is understood that Marshall's obligation with respect to equipment located outside the Continental United States, Canada or Hawaii is limited to replacement parts only.

"The following broiler parts have a six month part warranty:

- Burner Shields and Screens
- Burner Grids
- Burner Gaskets
- Electric Broiler Elements
- Flame Runners

Because Marshall does not and cannot control Purchaser's installation, use, and maintenance of equipment manufactured by Marshall, this warranty DOES NOT COVER:

Any equipment calibration;

Any component disassembled in the field;

Damage due to improper cleaning and/or abuse, i.e. burner rotation, grease accumulation in electrical components or plugs (hosing or "watering down" equipment will cause electrical failures not covered by warranty);

Blown fuses or bulbs, motor brushes and Teflon components;

Any replacement parts used on the equipment which are not purchased from Marshall;

Accessory components not installed or manufactured by Marshall.

Shipping damage must be reported to the carrier and is not covered under this warranty. Marshall will not be liable for damage as a result of improper installation, misuse, abuse, alteration of original design, incorrect voltage, unauthorized service, breakage of fragile items, or any other damage caused by an act out of Marshall's control.

The effect of corrosion, fire, and normal wear on the equipment or component parts is not covered by this warranty. This warranty does not cover cooking performance, smoke capture or holding temperatures which is a function of food types, textures, temperatures, equipment line ups and other variables chosen by the Purchaser and over which Marshall has no control. This warranty does not apply to damage caused by accident or to damage caused by the negligence of Purchaser or the employees of Purchaser or to damage caused by lightning generated electrical current or any other Act of God whatsoever. This warranty does not apply to any equipment bearing a serial number which has been tampered with or altered. Marshall reserves the right to accept or reject any such claim in whole or in part. Marshall will not accept the return of any product without prior written approval from Marshall, and all such approved returns shall be made at Purchaser's sole expense.

THIS WARRANTY IS IN LIEU OF ALL OTHER WARRANTIES, EXPRESS OR IMPLIED, INCLUDING THE IMPLIED WARRANTY OF MERCHANTABILITY AND THE IMPLIED WARRANTY OF FITNESS FOR A PARTICULAR PURPOSE, OR PATENT OR OTHER INTELLECTUAL PROPERTY RIGHT INFRINGEMENT, AND EXCEPT FOR THE EXPRESS WARRANTY CONTAINED HEREIN, THE EQUIPMENT IS SOLD "AS IS." REMEDIES UNDER THIS WARRANTY AND UNDER ANY WARRANTY THAT MAY SURVIVE THE DISCLAIMER OF WARRANTIES ARE LIMITED EXCLUSIVELY TO THOSE REMEDIES DESCRIBED ABOVE. NO OTHER REMEDY IS AVAILABLE UNDER THIS WARRANTY OR ANY OTHER WARRANTY. NEITHER THIS WARRANTY NOR ANY OTHER WARRANTY COVERS, AND MARSHALL WILL NOT BE RESPONSIBLE FOR, ANY INCIDENTAL OR CONSEQUENTIAL DAMAGES, INCLUDING BUT NOT LIMITED TO THE COST OF DISASSEMBLY AND SHIPMENT OF THE EQUIPMENT, PRODUCTION OR PRODUCT LOSSES, INJURY TO OTHER PROPERTY, OR LOST PROFITS RESULTING FROM THE USE OF OR INABILITY TO USE THE PRODUCTS OR FROM THE PRODUCTS BEING INCORPORATED IN OR BECOMING A COMPONENT OF ANY OTHER PRODUCT OR GOODS, OR OTHER LOSSES. WHERE, DUE TO OPERATION OF LAW, CONSEQUENTIAL AND INCIDENTAL DAMAGES CANNOT BE EXCLUDED, THEY ARE EXPRESSLY LIMITED IN AMOUNT TO THE PURCHASE PRICE OF THE EQUIPMENT.

FOR INTERNATIONAL INSTALLATIONS -- PLEASE CONTACT YOUR LOCAL MARSHALL AIR SYSTEMS RECOGNIZED DISTRIBUTOR.

## **BROILER WARRANTY PROCEDURES**

### **RETURN GOODS AUTHORIZATION FOR PARTS - FACTORY DIRECT**

For prompt warranty parts replacement and RGA processing, please call Marshall's Customer Service Department at 800-722-3474 or 704-525-6230 for assistance. In all cases, a Return Goods Authorization (RGA) number must be issued by Marshall Air Systems, Inc. Unauthorized returns will not be processed.

Option #1: Purchaser to return part prepaid to Factory, Marshall to repair or replace at own expense if defective, and ship part back to Purchaser prepaid.

Option #2: Marshall to furnish replacement part freight prepaid with or without requesting return of the defective part.

### **WARRANTY LABOR REIMBURSEMENT AND/OR PARTS REPLACEMENT THROUGH RECOGNIZED MAINTENANCE & REPAIR CENTERS**

Normally, labor will be covered under the start up fee. In the unlikely event this does not apply, consult Marshall Air Systems, Inc. To be reimbursed for warranty labor costs, authorization must be given by Marshall Air Systems, Inc. Unauthorized work will not be reimbursed. Work must be performed by a Marshall Air Systems Recognized Service Agency within the service time allowance guidelines and must be submitted along with failed parts (if applicable) to Marshall Air Systems (freight prepaid) within 30 days of the work being performed. Travel is covered, but must not exceed 50 miles or 1 hour, whichever is greater. Call Marshall's Service Department at 800-722-3474 or 704-525-6230 with any questions. Service is to be performed by recognized service agencies during normal working hours. Owner to pay for all other charges including excessive travel or overtime charges. **DIAGNOSTIC LABOR CHARGES ARE INCLUDED IN SERVICE TIME ALLOWANCE GUIDELINES.** All portable equipment (under 90 pounds) shall be delivered by Purchaser, at his/her expense, to the nearest authorized service agency for in-shop repair or at purchaser's discretion he/she will pay all travel time and mileage expenses for portable equipment.

### **NON-WARRANTY RETURNS:**

All items returned for customer convenience are subject to a 20% restocking fee. In the event of an error by Marshall Air Systems, Inc., a Returned Goods Authorization will be issued for full credit.

### **FOR INTERNATIONAL INSTALLATIONS -- PLEASE CONTACT YOUR LOCAL MARSHALL AIR SYSTEMS RECOGNIZED DISTRIBUTOR.**

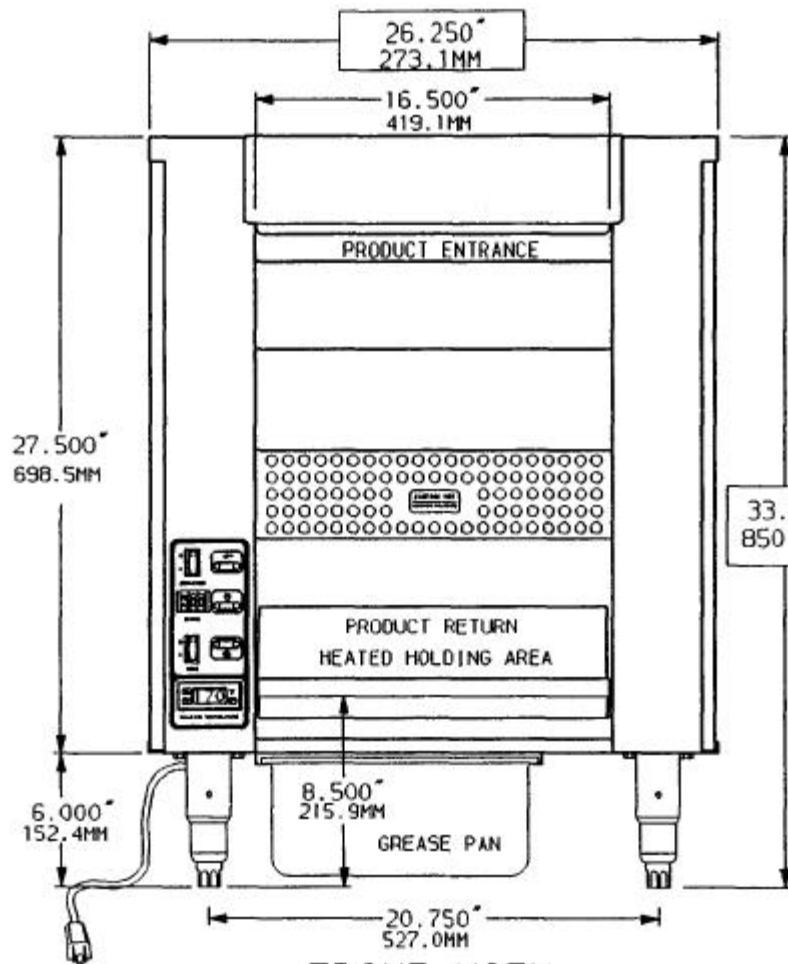

FRONT VIEW

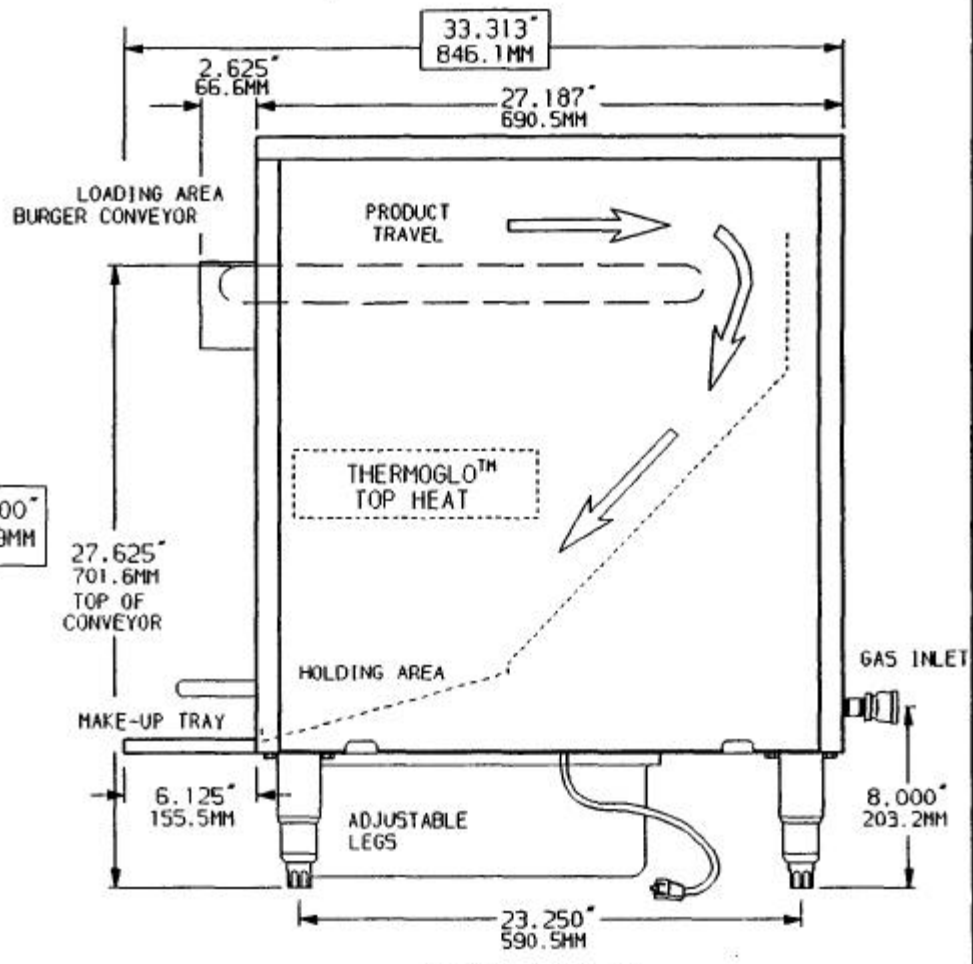

SIDE VIEW

GAS BROILER (COOKING) & ELECTRIC (HOLDING UNIT)  
 NATURAL GAS BTUH: 61,000 MANIFOLD PRESSURE: 5/4  
 PROPANE GAS BTUH: 61,000 MANIFOLD PRESSURE: 10.3/7  
 VOLTS: 120 PHASE: 1 HZ: 60 AMPS: 7  
 OR VOLTS: 240 PHASE: 1 HZ: 50 AMPS: 3.5

BROILER LAYOUT FR15BG  
 FIGURE 1

240VOLT 50HZ PARTS ARE LISTED ON PAGE 18

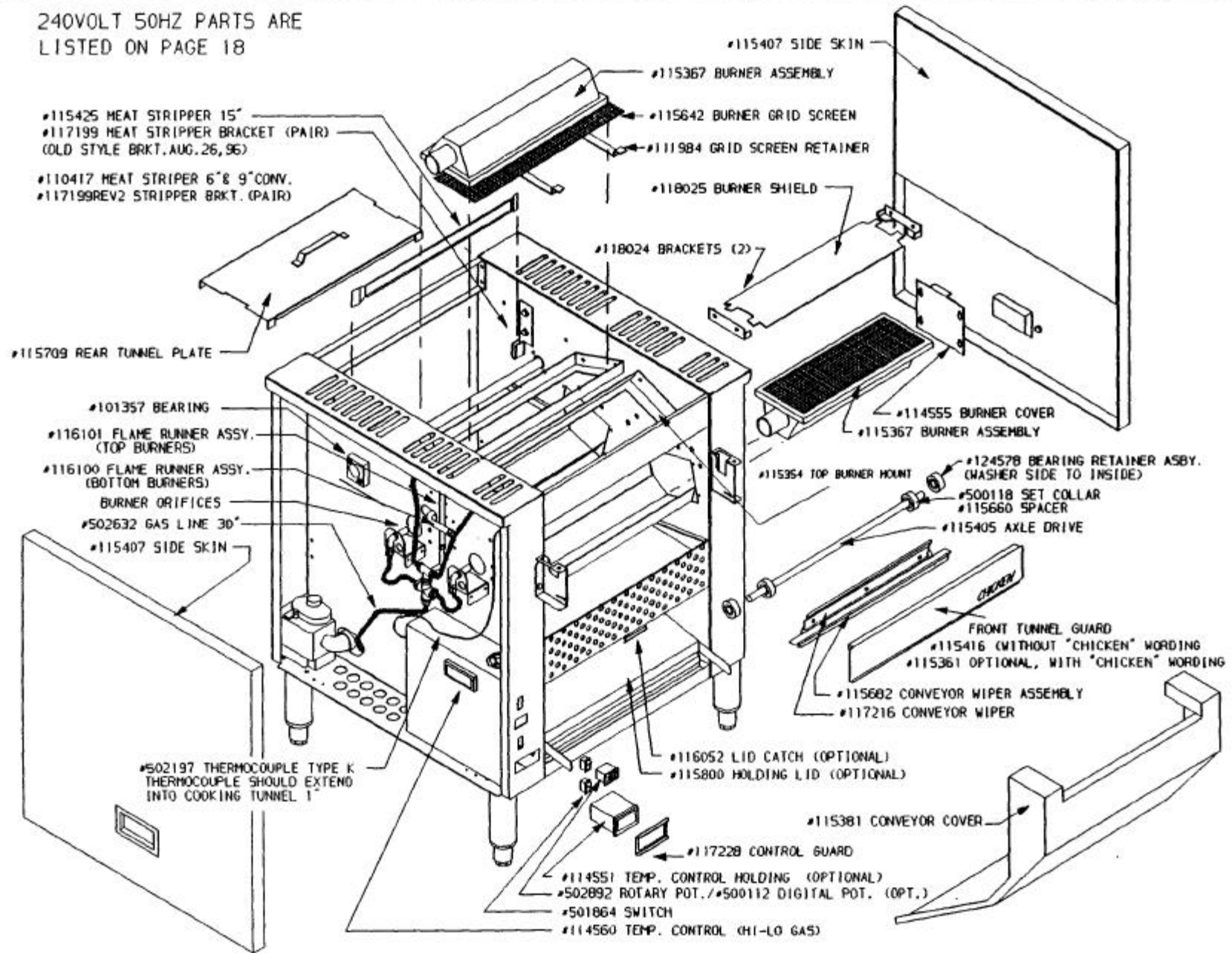

EXPLODED VIEW  
FIGURE 2

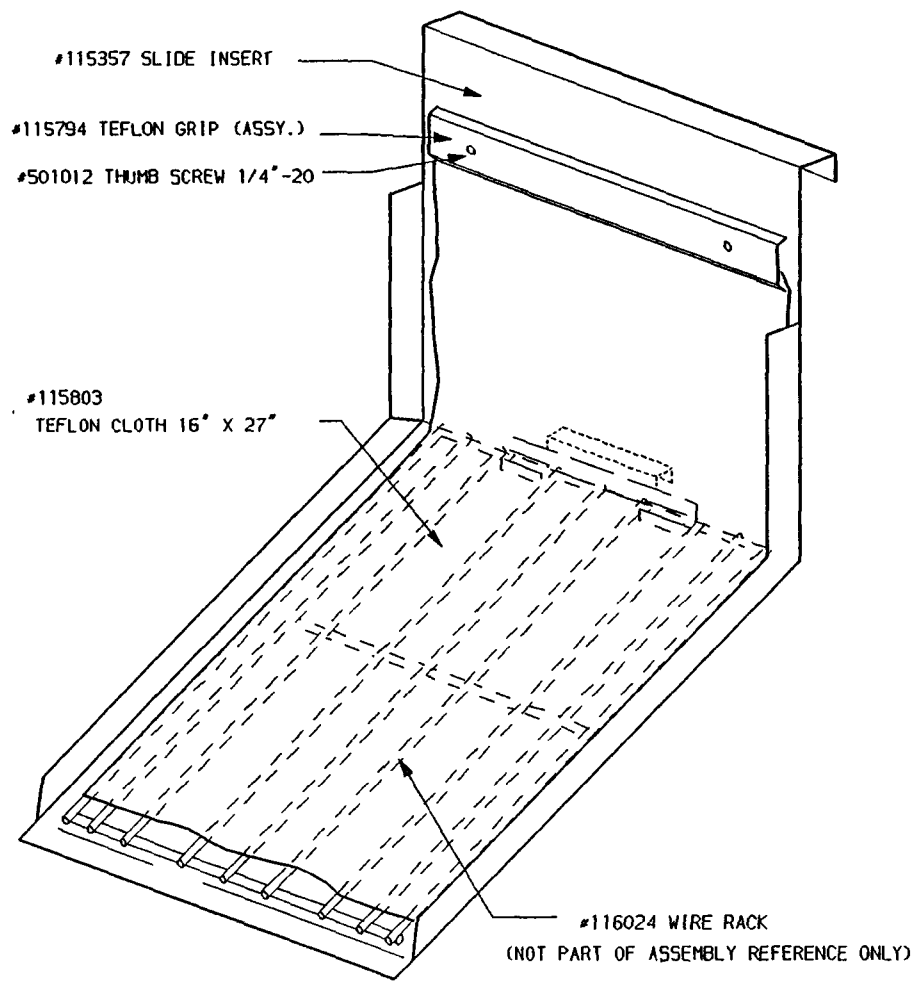

#115799 SLIDE ASSEMBLY

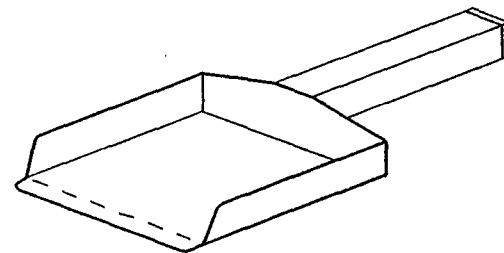

#115695 BROILER SPATULA  
(OPTIONAL)

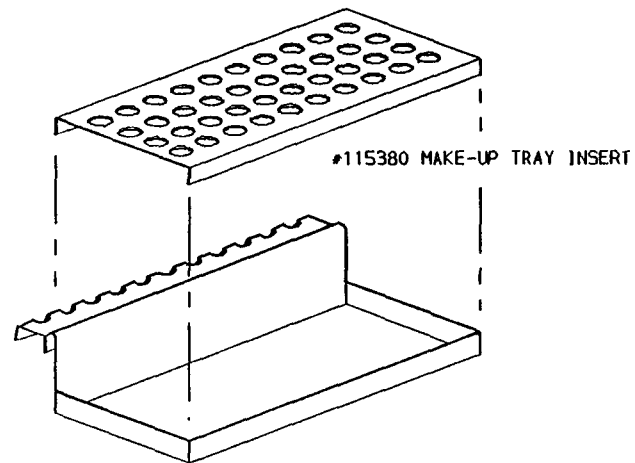

#115694 BURGER TRAY & STOP ASSEMBLY

SLIDE ASSEMBLY  
FIGURE 3

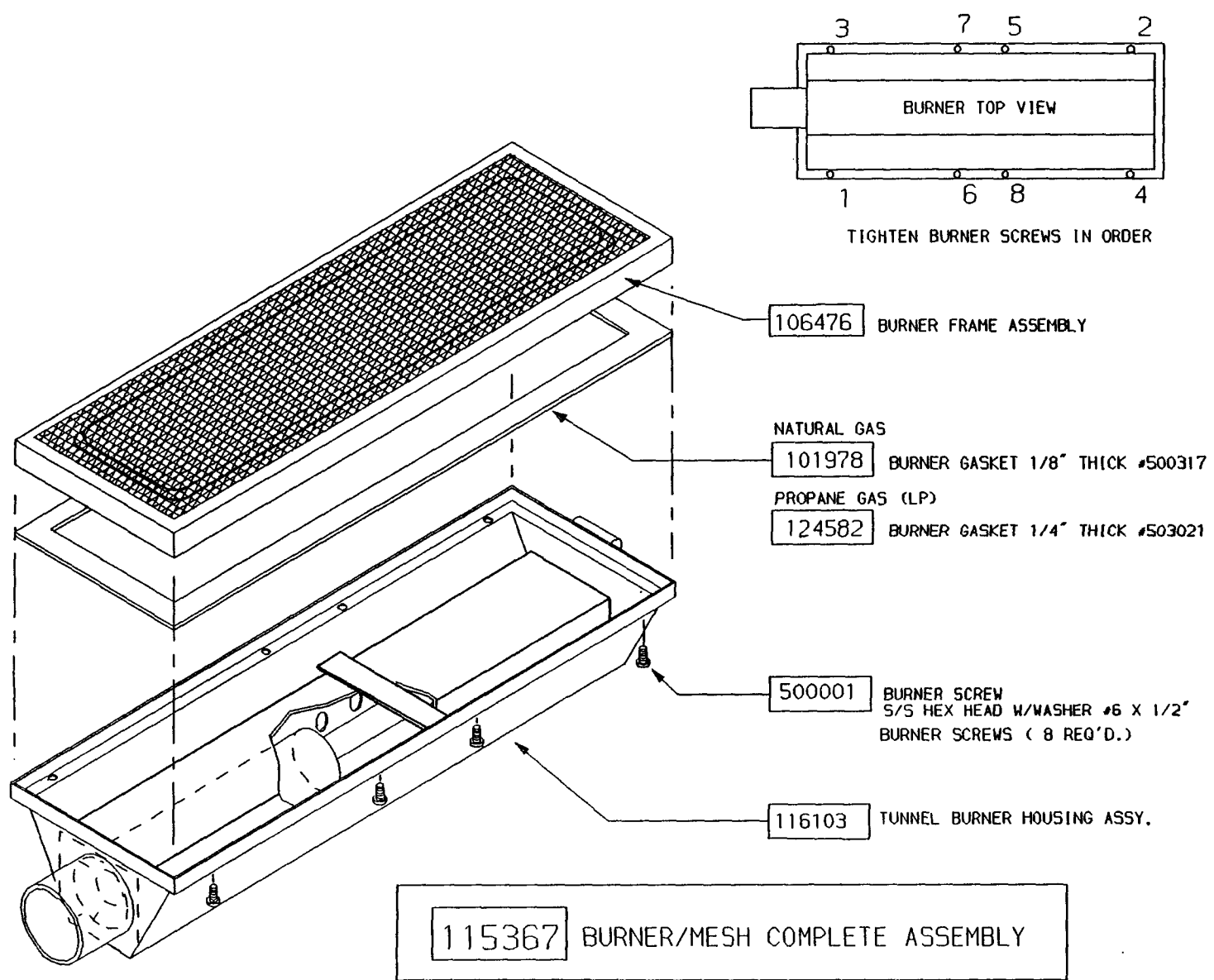

BURNER ASSEMBLY  
FIGURE 4

① 3/8" FLEX CONDUIT RUN FROM SELENOID TO CONTROL BOX.

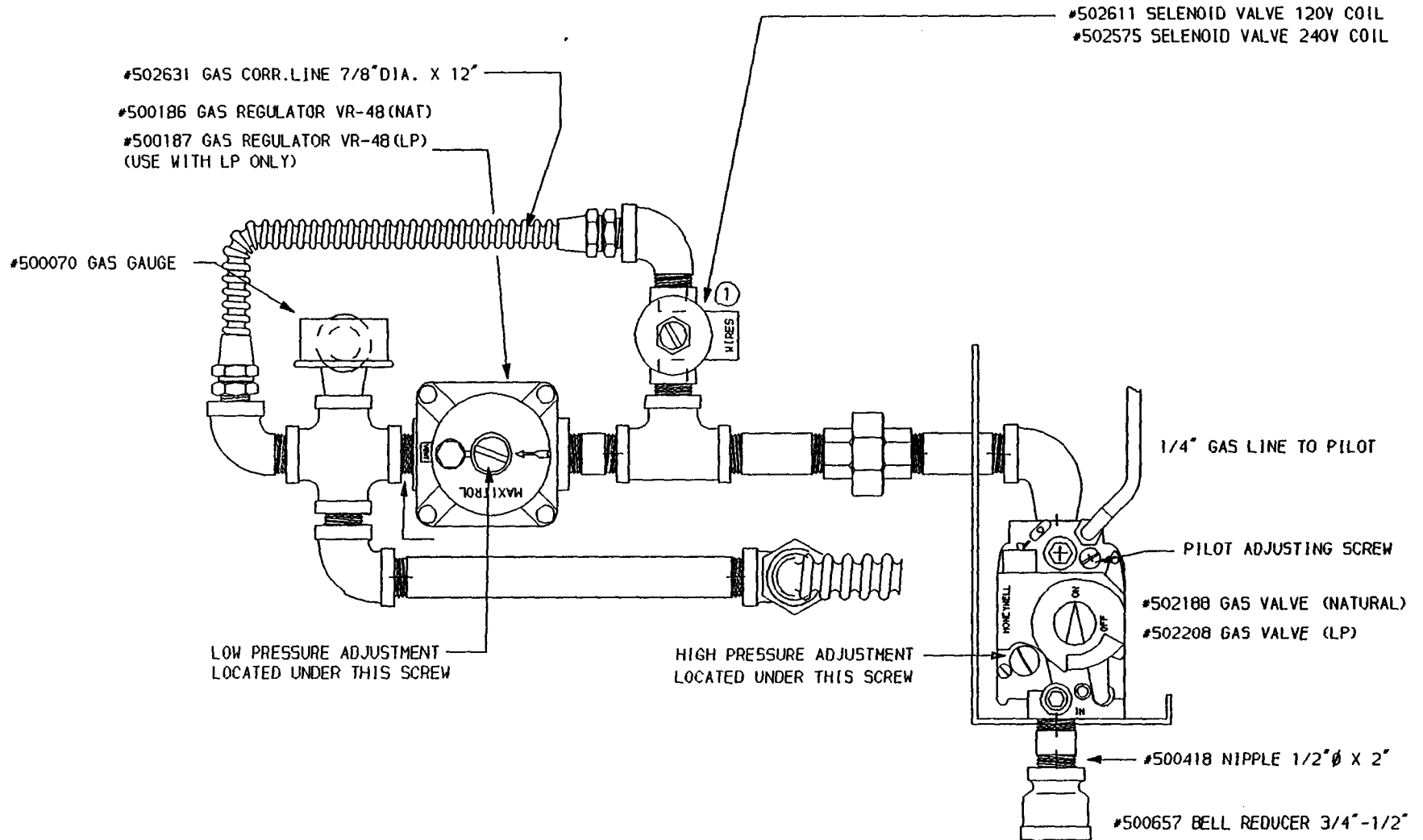

GAS DISTRIBUTION SYSTEM  
FIGURE 5

#500026 CONVEYOR 15" (PER FOOT)  
 #104679 LINK CONVEYOR BELT 15" (EACH)  
 #500033 PLIERS CHAIN CONVEYOR

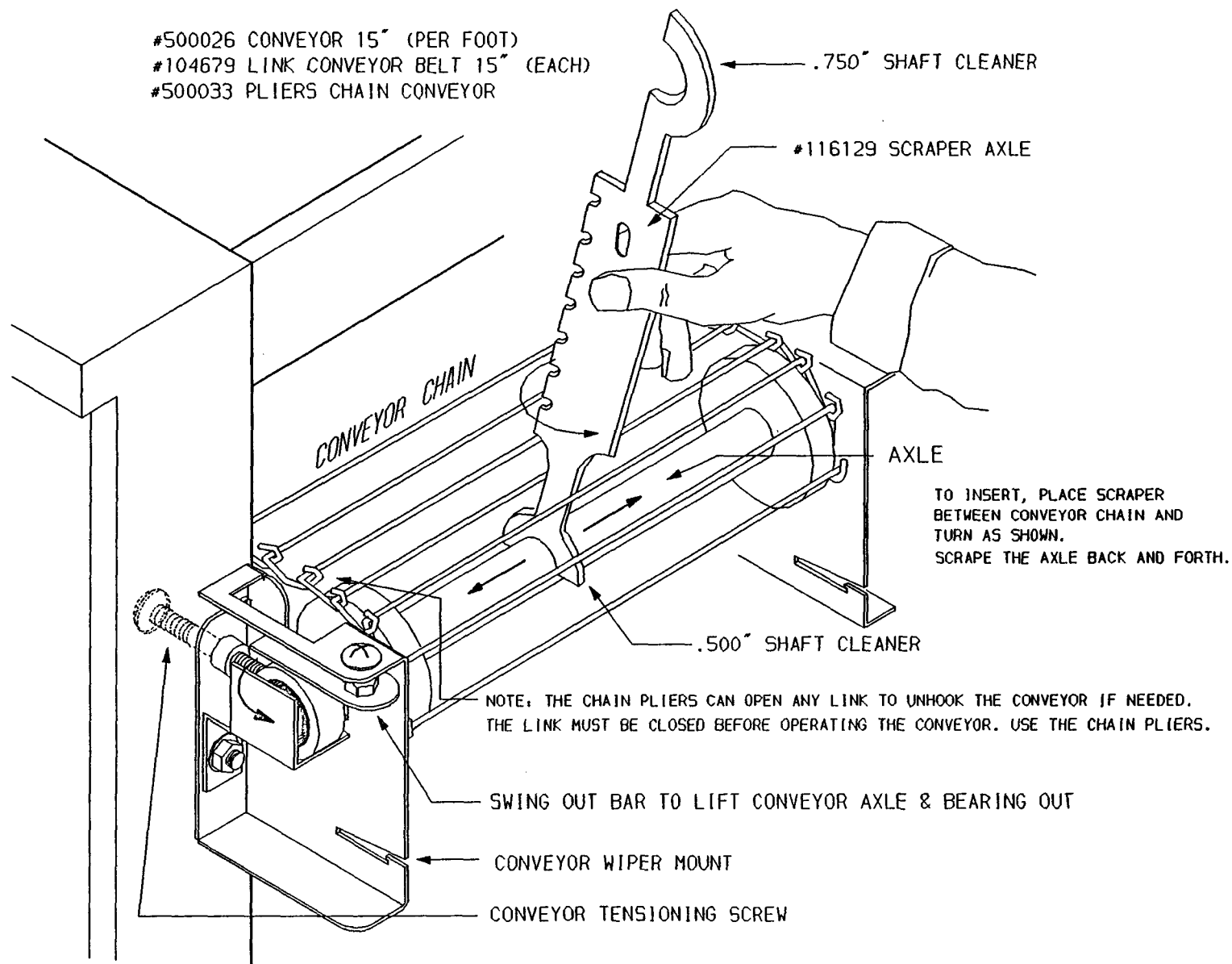

TO INSERT, PLACE SCRAPER  
 BETWEEN CONVEYOR CHAIN AND  
 TURN AS SHOWN.  
 SCRAPE THE AXLE BACK AND FORTH.

NOTE: THE CHAIN PLIERS CAN OPEN ANY LINK TO UNHOOK THE CONVEYOR IF NEEDED.  
 THE LINK MUST BE CLOSED BEFORE OPERATING THE CONVEYOR. USE THE CHAIN PLIERS.

SWING OUT BAR TO LIFT CONVEYOR AXLE & BEARING OUT  
 CONVEYOR WIPER MOUNT  
 CONVEYOR TENSIONING SCREW

AXLE SCRAPER  
 FIGURE 6

(FOR USE WITH MOVABLE GAS APPLIANCES)

Per ANSI Regulations Under:

Z-21.69-1979 & Z-21.69a-1983 (CONNECTORS)

Z-21.41b-1983 (QUICK DISCONNECT DEVICES)

With current revisions.

NOTE: THIS RESTRAINING DEVICE MUST ALWAYS BE CONNECTED WHEN THE APPLIANCE IS IN SERVICE. DISCONNECT FOR MOVEMENT SUCH AS SERVICING OR CLEANING. THEN RECONNECT THIS RESTRAINT WHEN THE APPLIANCE HAS BEEN RETURNED TO ITS NORMAL POSITION.

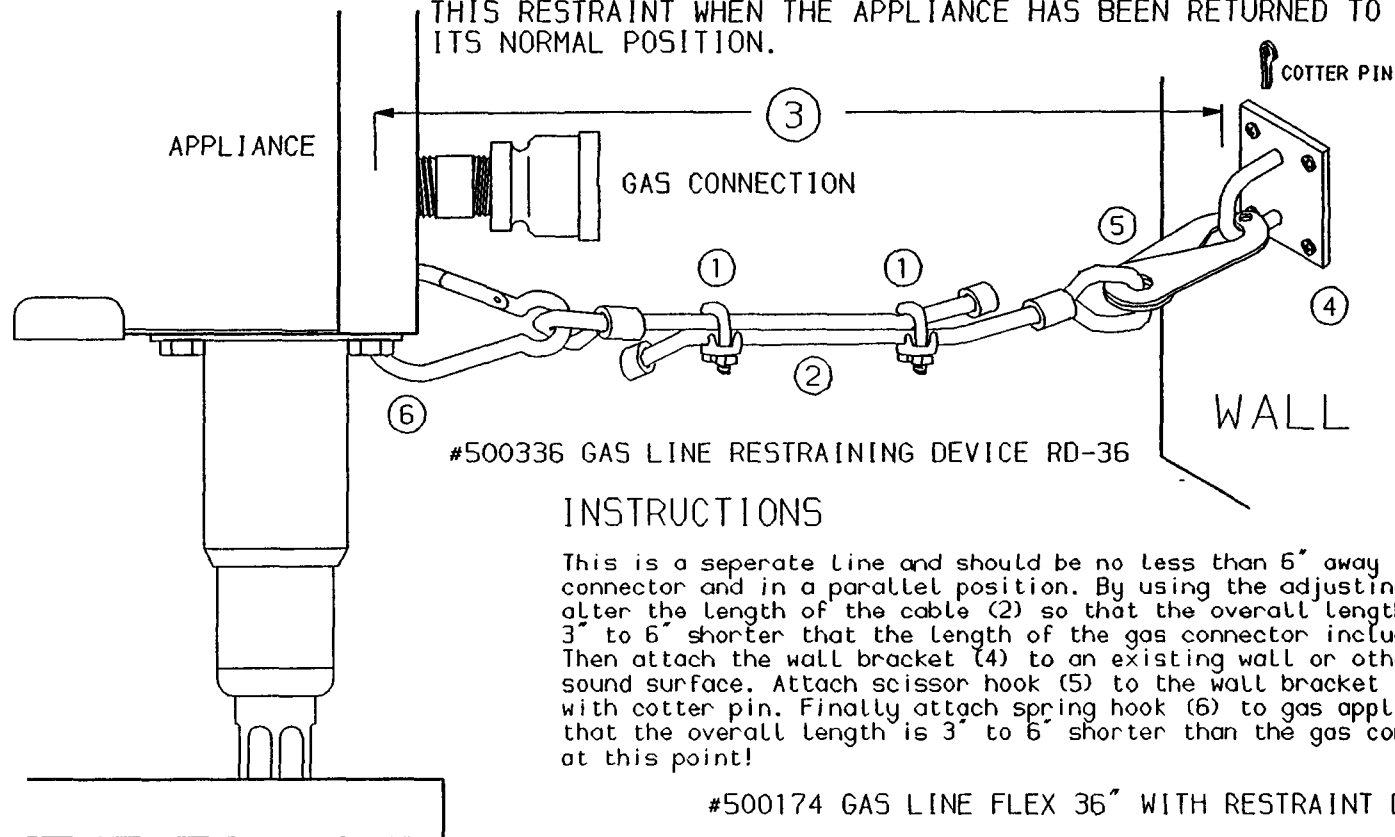

### INSTRUCTIONS

This is a separate line and should be no less than 6" away from the gas connector and in a parallel position. By using the adjusting clamps (1) alter the length of the cable (2) so that the overall length (3) is 3" to 6" shorter than the length of the gas connector including the fittings. Then attach the wall bracket (4) to an existing wall or other architecturally sound surface. Attach scissor hook (5) to the wall bracket (4) and secure with cotter pin. Finally attach spring hook (6) to gas appliance. Make certain that the overall length is 3" to 6" shorter than the gas connector at this point!

#500174 GAS LINE FLEX 36" WITH RESTRAINT DORMONT

RESTRAINING DEVICE

FIGURE 7

BACK OF BROILER

BROILER ENTRANCE

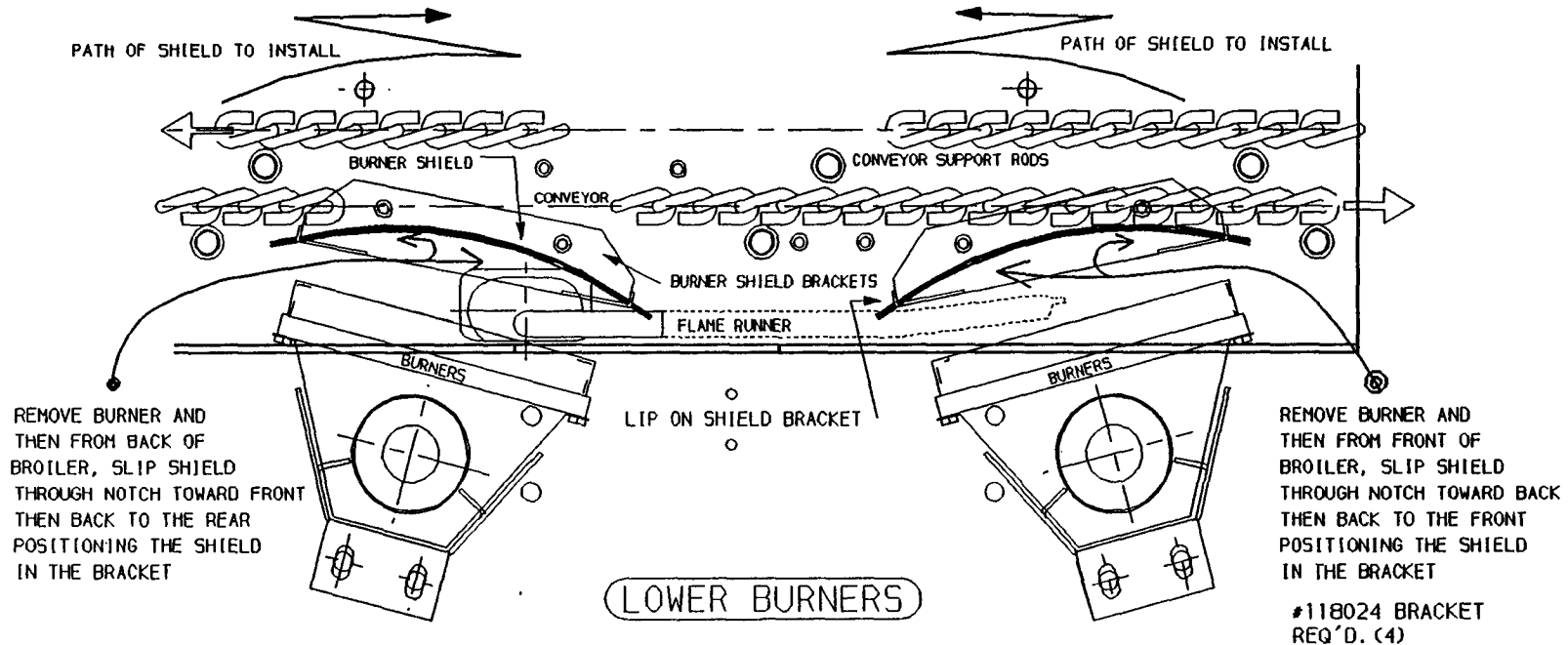

REMOVE BURNER AND THEN FROM BACK OF BROILER, SLIP SHIELD THROUGH NOTCH TOWARD FRONT THEN BACK TO THE REAR POSITIONING THE SHIELD IN THE BRACKET

REMOVE BURNER AND THEN FROM FRONT OF BROILER, SLIP SHIELD THROUGH NOTCH TOWARD BACK THEN BACK TO THE FRONT POSITIONING THE SHIELD IN THE BRACKET

#118024 BRACKET  
REQ'D. (4)

1. LOWER BURNER SHIELDS SHOULD BE REMOVED FOR CLEANING COOKING RESIDUE FROM THEIR UPPER SURFACE
2. WHEN REINSTALLING MAKE CERTAIN SHIELDS ARE NOT BENT OR TWISTED
3. SHIELD MUST REST IN BURNER SHIELD BRACKET AND BE TRAPPED BY LIP ON BRACKET

#118025 LOWER BURNER SHIELD

BURNER SHIELD INSTALLATION  
FIGURE 8

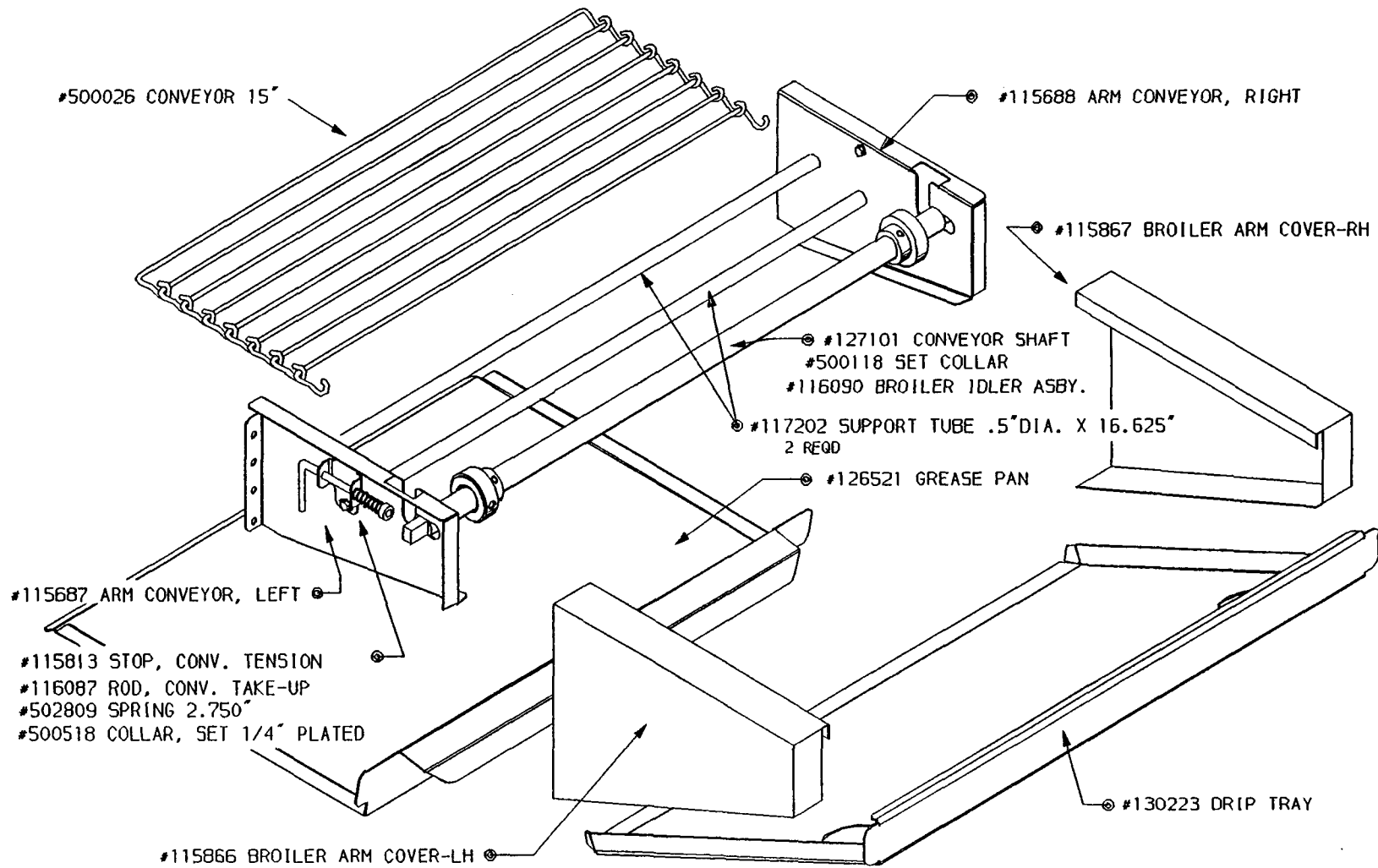

KIT, BROILER ARM EXTENSION 15" (OPTIONAL)  
(130224)

FIGURE 9

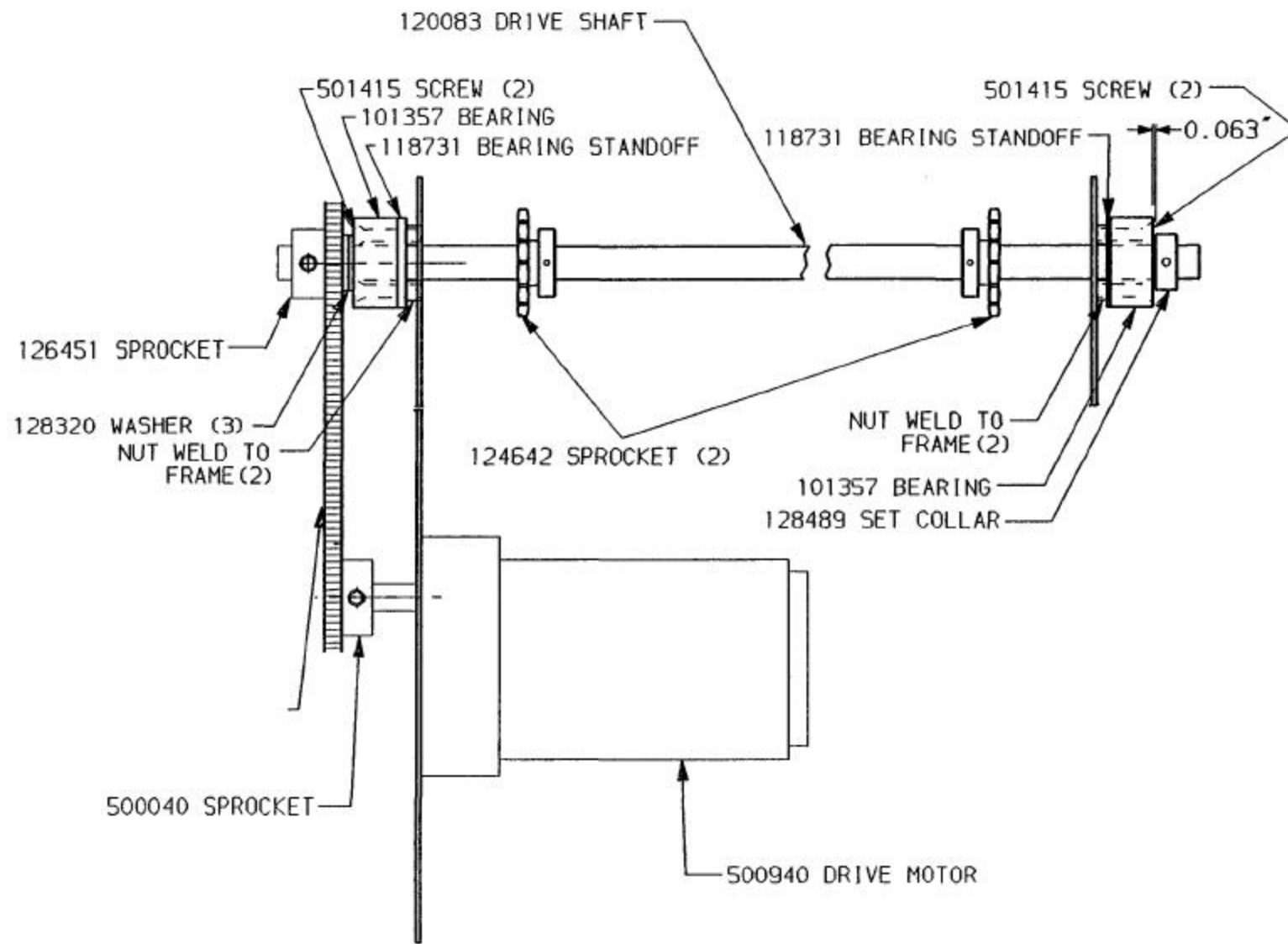

DRAWING IS NOT TO SCALE

DRIVE ASBY (125650)  
**FIGURE 10**

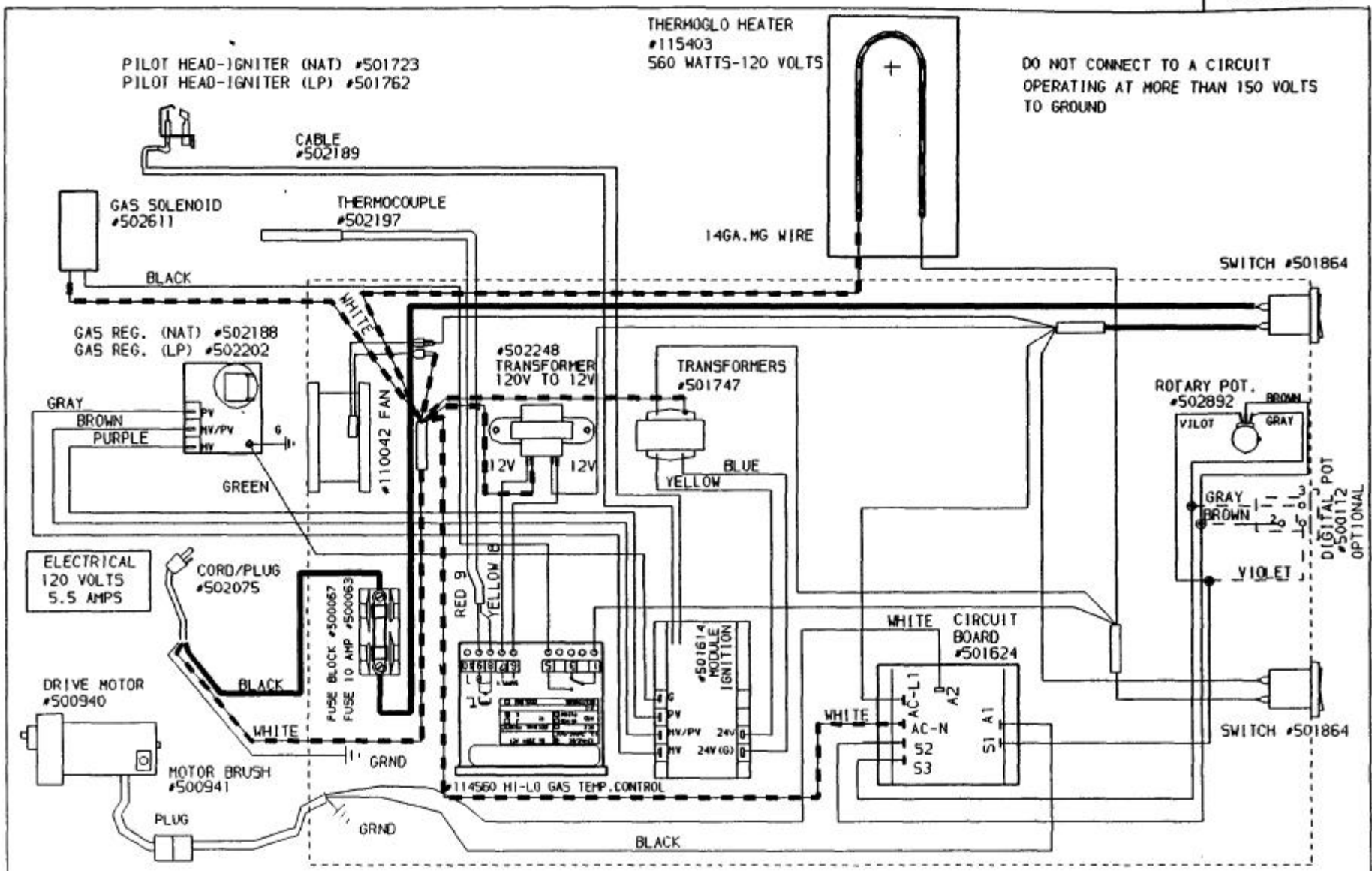

DO NOT CONNECT TO A CIRCUIT OPERATING AT MORE THAN 150 VOLTS TO GROUND

REV	DATE	DESCRIPTION	R. S.	28-FEB-92	MARSHALL AIR SYSTEMS, INC.		
1	19-OCT-92	ADDED NOTE IN UPPER RIGHT CORNER			SCHEMATIC, FR15BG 120V 60Hz W/O HOLD		
2	27-JAN-93	CH. TO NEW TEMP. CONTROLLER. (JR)					
3	14-JUL-93	SOLENOID PART # WAS 501638					
4	02-MAR-94	ADD PART NO. CORD, MOTOR BRUSH, CH. FAN PART NO. (JR)					
5	28-JUN-95	CH. SENSOR LOC. ON TEMP. CONTROLLER. (JR)					
6	13-MAY-97	ADDED WIRE COLORS TO THERMOCOUPLE AT TEMP. CONT. (CP)					
7	09-JUL-97	THERMOGLO #115403 WAS ELEMENT #502472 (BL)					
			REFERENCE	A	DWG NO.	114558	REV 7
			"X"	SCALE	1:1 DRAWING MAY BE REDUCED CODE: H6, AE9A		

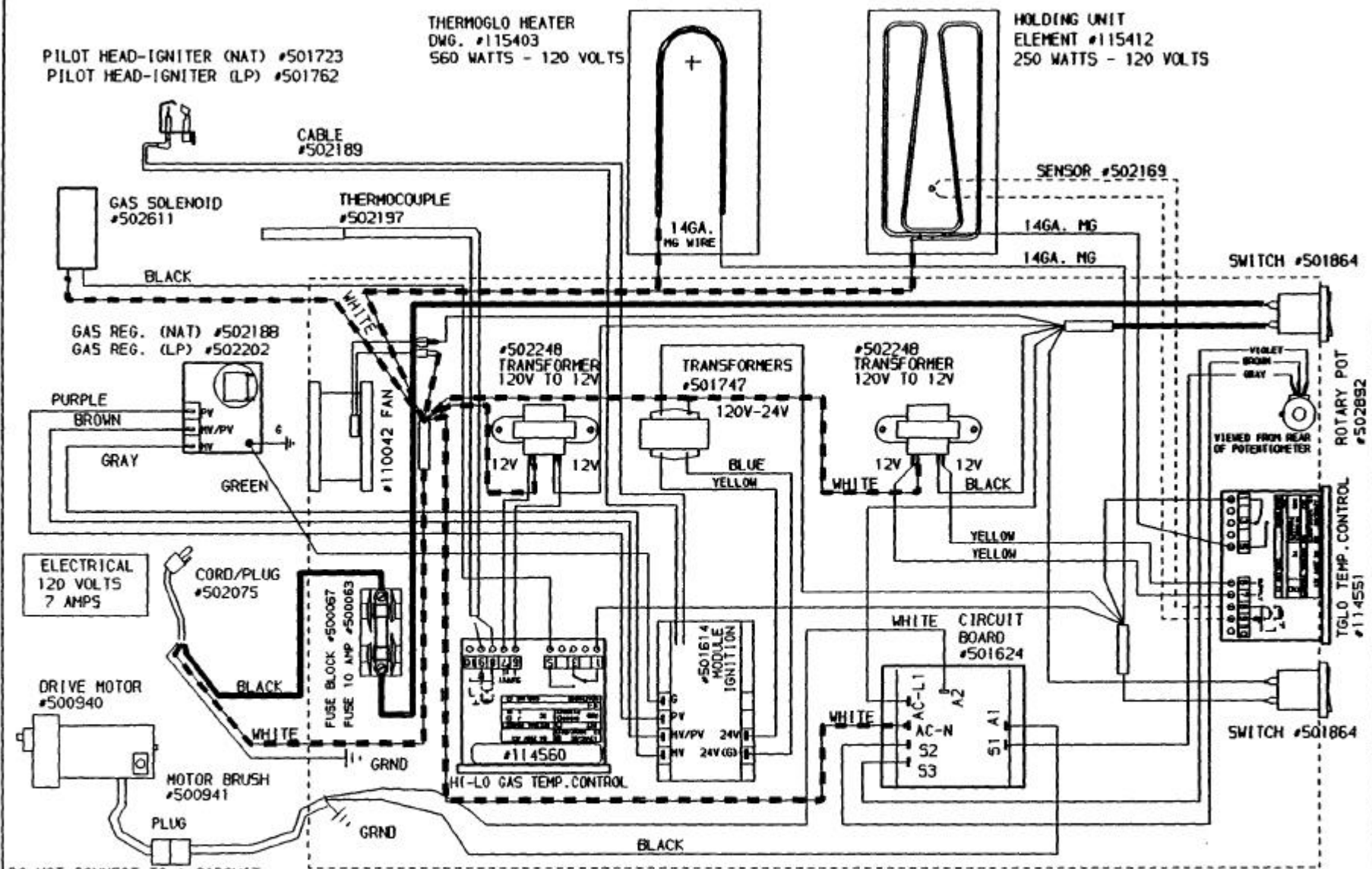

DO NOT CONNECT TO A CIRCUIT OPERATING AT MORE THAN 150 VOLTS TO GROUND

120VOLTS, 60HZ, 7AMPS

REV	DATE	DESCRIPTION	R. S.	28-FEB-92	MARSHALL AIR SYSTEMS, INC.
7	28-JUN-95	CH. SENSOR LOC. ON TEMP. CONTROLLER. (JR)			SCHEMATIC, FR15BG, 120V, 60Hz, 7A, W/TGLO
8	09-JUL-97	THERMOGLO #115403 WAS #502472 (BL)			
9	12-AUG-97	CORRECTED THE ROTARY POT CONNECTIONS (BL)			
10	29-OCT-97	CHG MV TO HV AND PV TO PV WIRING (PW)			
			CODE: AE9	DWG NO. 114559	REV

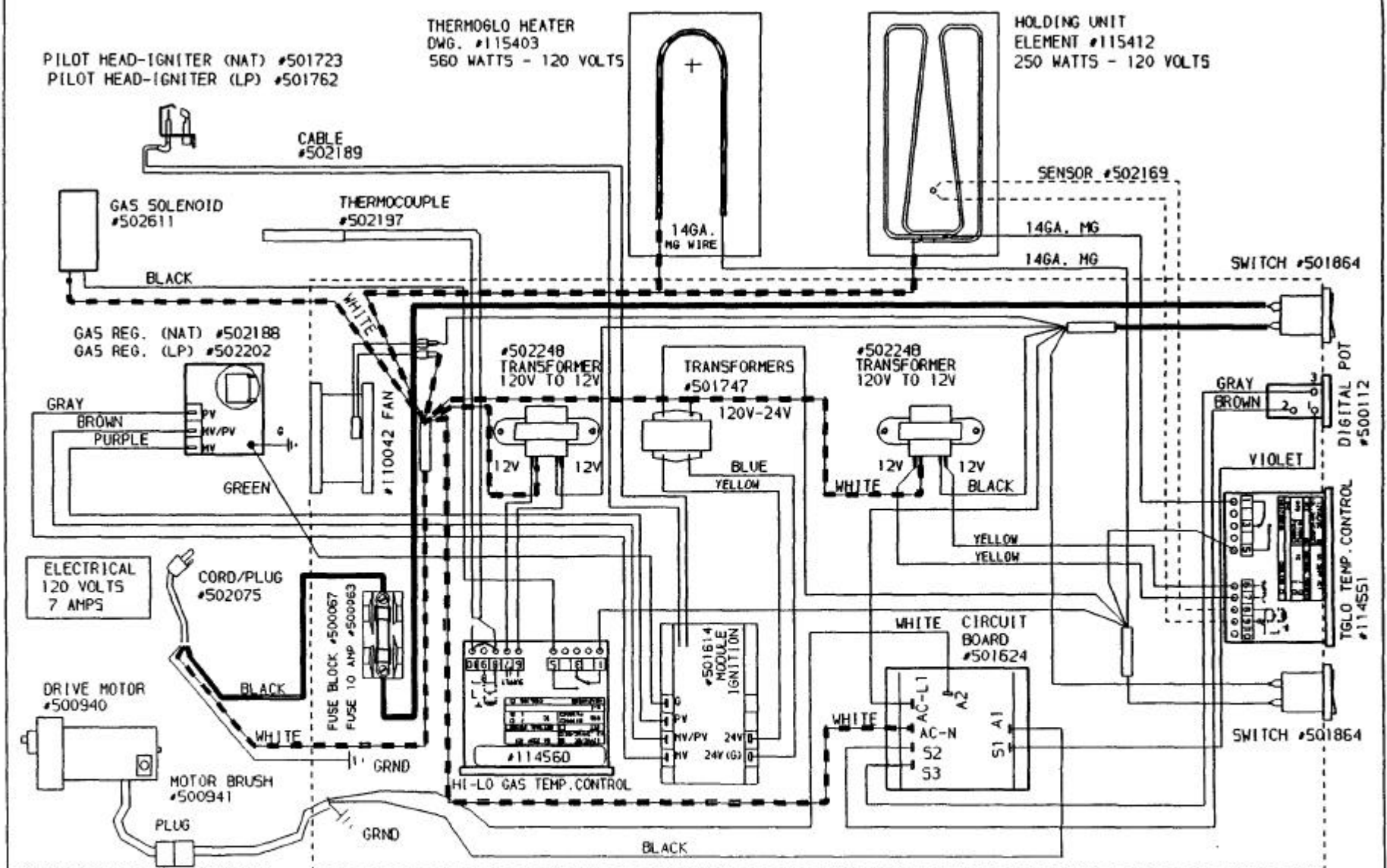

DO NOT CONNECT TO A CIRCUIT OPERATING AT MORE THAN 150 VOLTS TO GROUND

120 VOLTS, 7 AMPS

REV	DATE	DESCRIPTION	R. S.	28-FEB-92	MARSHALL AIR SYSTEMS, INC.
1	19-OCT-92	NOTE IN LOWER LEFT CORNER ADDED			
2	27-JAN-93	NEW TEMP. CONTROLLERS. (JR)			
3	28-JUN-93	CH. CONTROLLER NO. 114550 TO #114551 (JR)	120 VOLTS, 7 AMPS		SCHEMATIC FR15BG ( WITH HOLDING ) UNIT
4	14-JUL-93	SOLENOID PART # WAS 501698			
5	03-MAR-94	ADD PART NO. MOTOR BRUSH (JR)			
6	09-JUL-97	THERMOGLO # 115403 WAS # 502472 (BL)			
			CODE: AES	DWG NO. 114559-5	REV 6

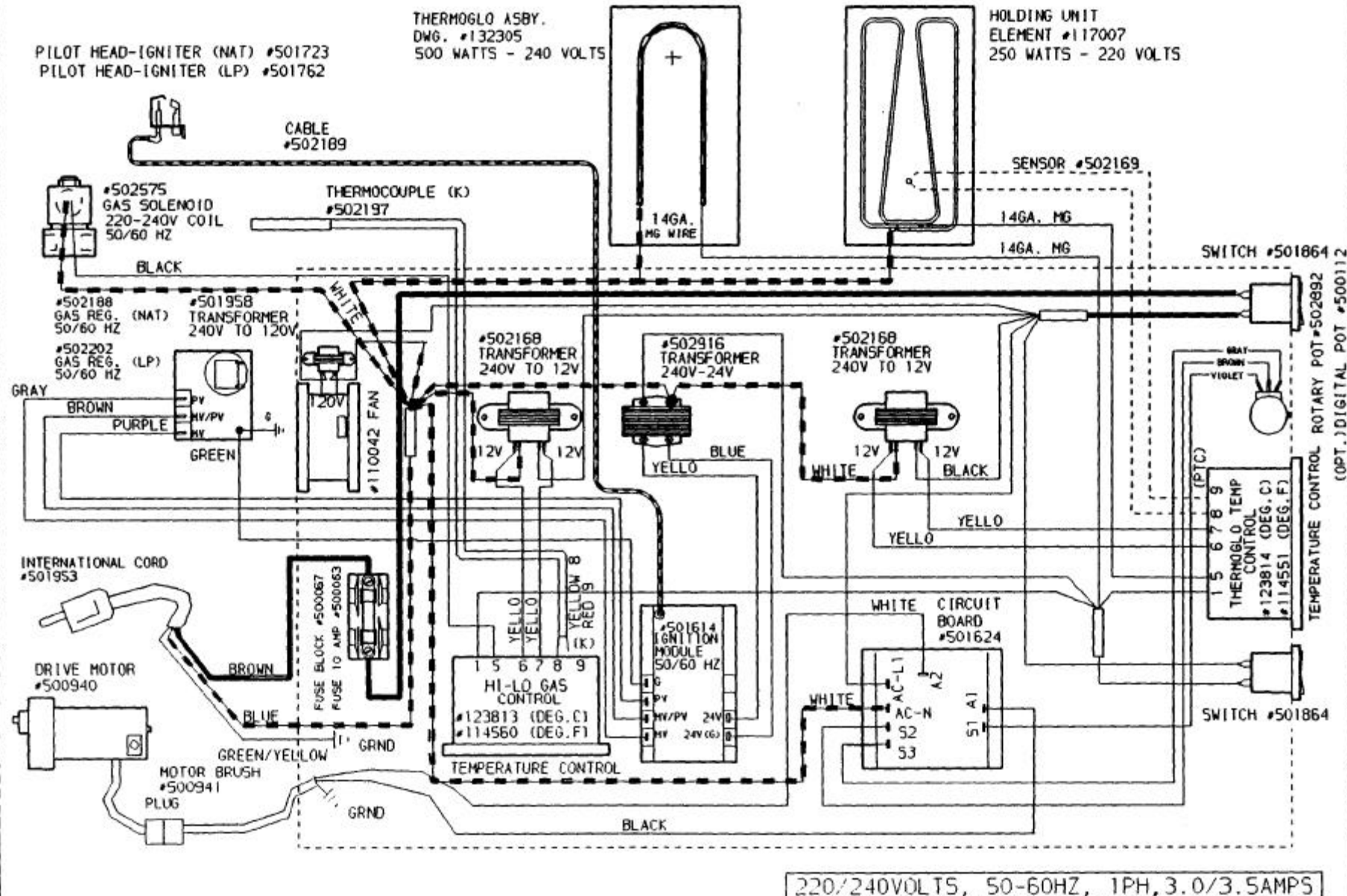

REV	DATE	DESCRIPTION	R. S.	28-FEB-92	MARSHALL AIR SYSTEMS, INC.		
8	01-AUG-95	CH. TRANSFORMER NO. #502576 TO #502916			SCHEMATIC, FR15BG W/HOLDING 220/240V		
9	13-MAY-97	ADDED THERMOCOUPLE WIRE COLORS AT TEMP CONT (CP)		220 VOLTS, 3.0 AMPS			
10	30-JUN-97	ADDED THERMOGLO ASBY AND DWG. # [BL]		240 VOLTS, 3.5 AMPS	CODE: AE91NTL	DWG NO. 117005	
						REV 10	

# CATERING EQUIPMENT MODELS

## STRAIGHT THRU MODELS

OPTIONS	
MODEL	DESCRIPTION
2424G	TWO MOTORS, ONE FOR EACH BELT
121224G	TWO MOTORS, THREE MOTORS OPTIONAL, ONE FOR EACH BELT
2424G	ONE MOTOR, DRIVES TWO BELTS

## FRONT RETURN MODELS

OPTIONS	
MODEL	DESCRIPTION
FR24BG	WITH TGLO WARMER WITH BLANKET HEATER
FR24BG	WITH TGLO WARMER WITHOUT BLANKET HEATER
FR24BG	WITHOUT TGLO WARMER WITHOUT BLANKET HEATER
FR1212BG	WITH TGLO WARMER WITH BLANKET HEATER
FR1212BG	WITH TGLO WARMER WITHOUT BLANKET HEATER
FR1212BG	WITHOUT TGLO WARMER WITHOUT BLANKET HEATER
FR15BG	WITH TGLO WARMER WITH LOWER HEATING ELEMENT
FR69BG	WITH OR WITHOUT HOLDING UNIT

ALL MODELS CAN BE EITHER ON FEET OR ON STAND WITH CASTERS.

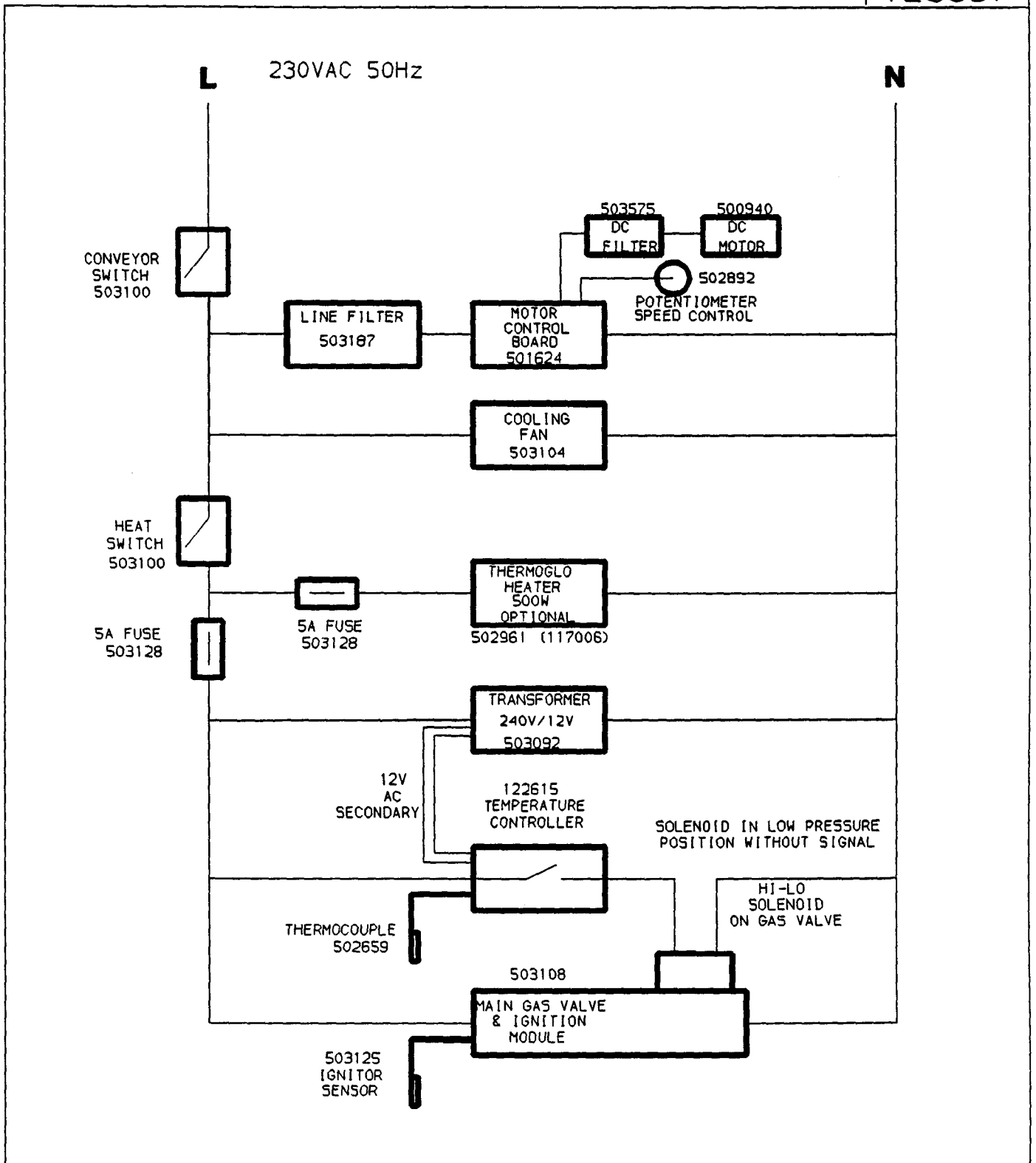

	C.P.	16-OCT-95	MARSHALL AIR SYSTEMS, INC.	
			ELECTRICAL LADDER DIAGRAM AUTOBROIL MODEL FR15BG	
REFERENCE	A		DWG NO. 126667	REV 1
---	"X"	SCALE	1:1	DRAWING MAY BE REDUCED CODE: AE9CE

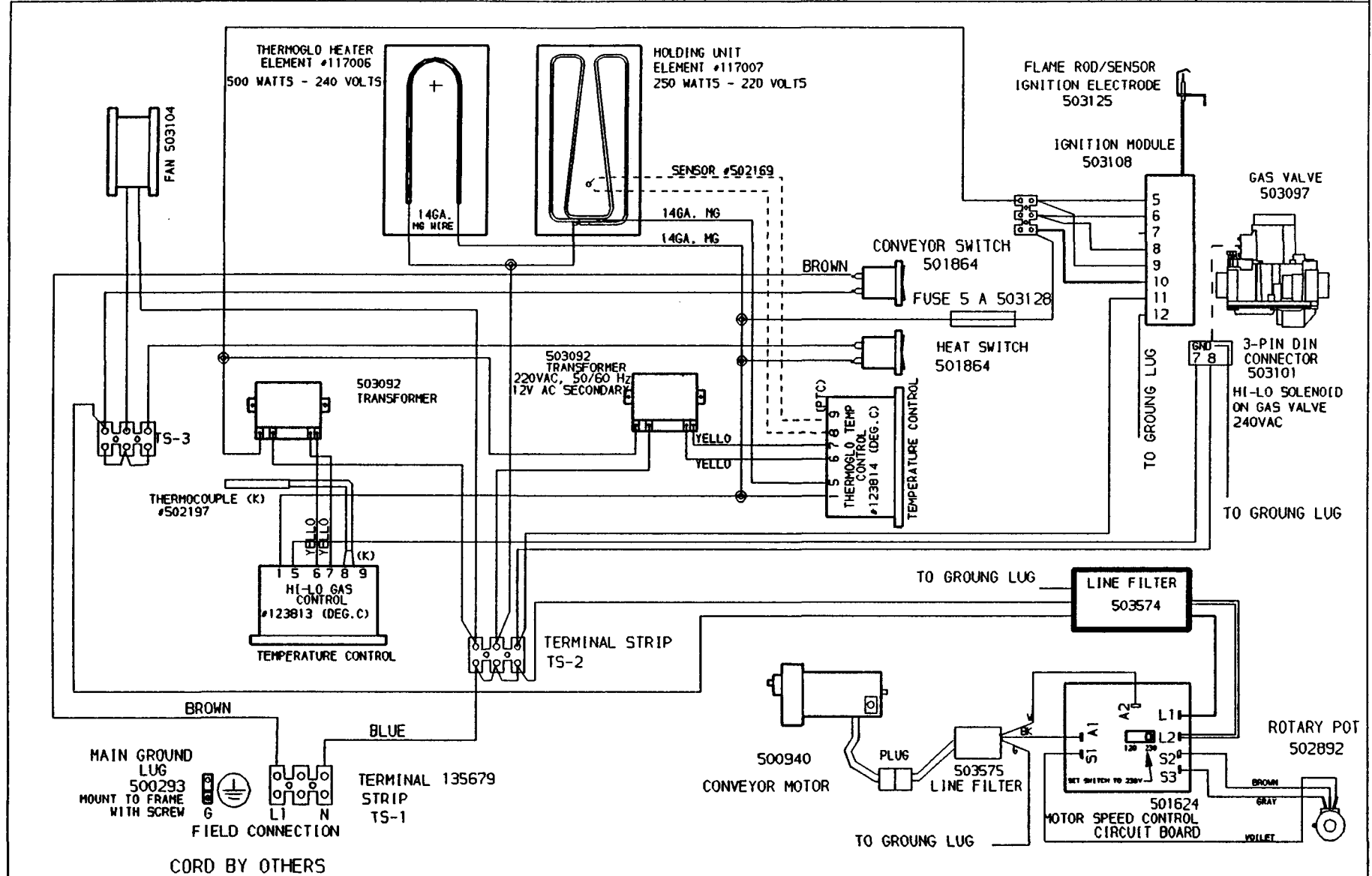

REV	DATE	DESCRIPTION	C.P.	28-AUG-95	MARSHALL AIR SYSTEMS, INC.			
					SCHEMATIC, FR15BG, 240V, 50Hz 1PH 3.5A			
					SIZE	PROJ.	DWG NO.	REV
					A		125871	0
					SCALE	IMAGE MAY BE REDUCED	CODE:	
					1:1	NTS	AE9CE	